

Installation sanleitung
Installation Instruction
Instruction d'installation

FULL HOUSE BED

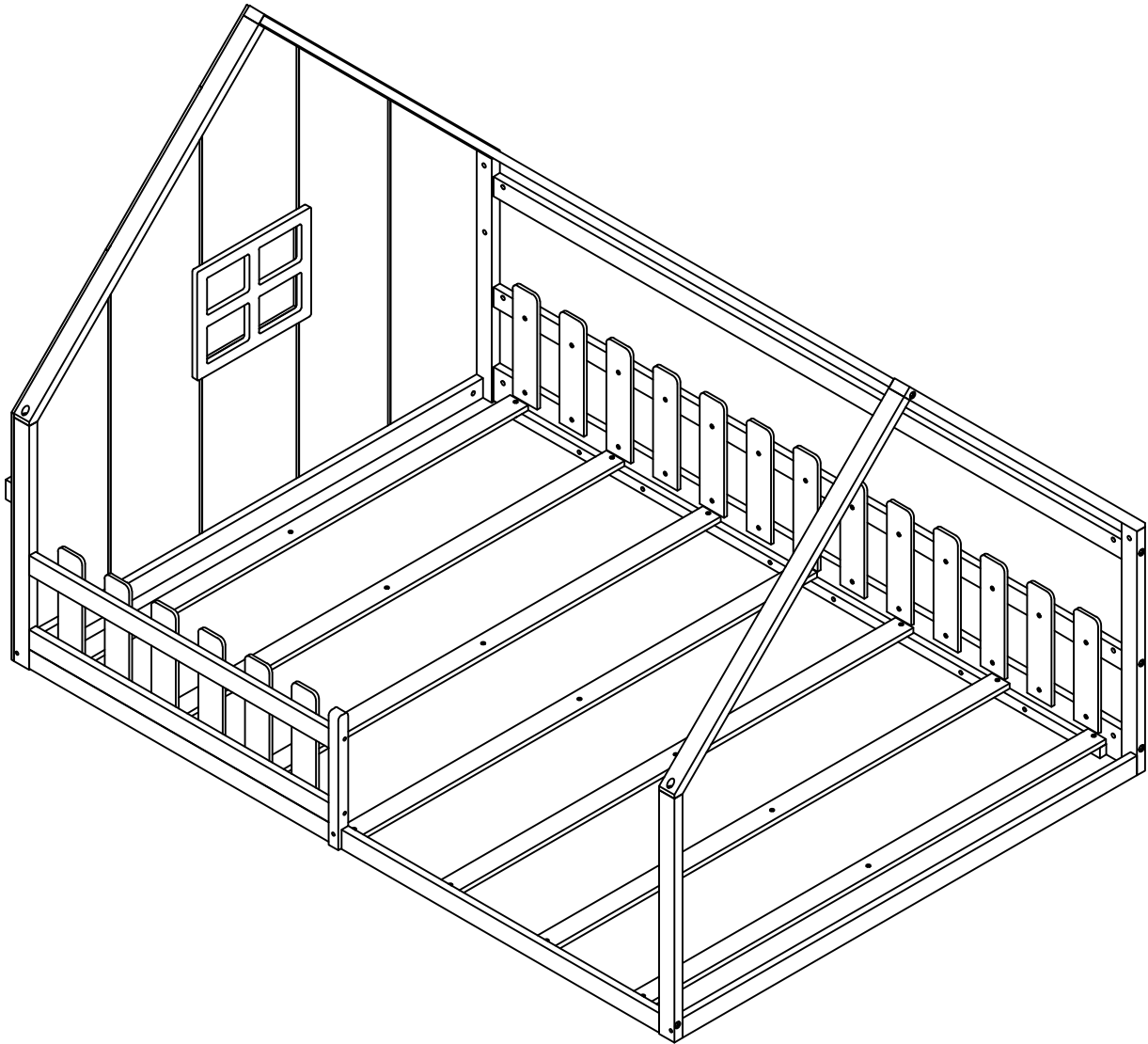

DE:Unser Produkt wird Ihnen in 2 Paketen geliefert. Die Lieferzeiten dieser 2 Pakete können abweichen, bitte haben Sie etwas Geduld und vielen Dank für Ihr Verständnis.

UK:Our product will be delivered to you in 2 packages. The delivery times of these 2 packages may differ please be patient and thank you for your understanding.

FR:Notre produit vous sera livré en 2 colis. Les délais de livraison de ces 2 colis peuvent différer, soyez patient et merci pour votre compréhension.

WF322720/WF322721

English

IMPORTANT ! KEEP FOR FUTURE REFERENCE : READ CAREFULLY

- To be assembled by an adult. Assembly must be checked by an adult before use
- WARNING ! Keep all screws, small parts and plastic bags out of the reach of children
- Properly identify all parts before assembling
- Never use your item if any of its parts are broken or missing
- Should any problems arise, please contact our After Sales Service
- Manufacturer's instructions shall be followed at all times
- Care: Clean with a soft, dry cloth. In case of larger stains, carefully rub with a slightly damp, non-abrasive sponge
- Avoid the risk of fire by not placing furniture near sources of ignition or hot items
- Do not jump on the bed

Deutsch

WICHTIG ! ZUM SPÄTEREN NACHSCHLAGEN AUFBEWAHREN: SORGFÄLTIG LESEN

- Muss von einem Erwachsenen zusammengebaut werden. Der Zusammenbau muss vor dem Gebrauch von einem Erwachsenen überprüft werden
- WARNUNG! Bewahren Sie alle Schrauben, Kleinteile und Plastikbeutel außerhalb der Reichweite von Kindern auf
- Kennzeichnen Sie vor dem Zusammenbau alle Teile richtig
- Benutzen Sie Ihren Artikel niemals, wenn Teile gebrochen sind oder fehlen
- Sollten Probleme auftreten, wenden Sie sich bitte an unseren Kundendienst
- Die Anweisungen des Herstellers sind stets zu befolgen
- Pflege: Mit einem weichen, trockenen Tuch reinigen. Bei größeren Flecken vorsichtig mit einem leicht feuchten, nicht scheuernden Schwamm abreiben. nicht scheuernden Schwamm
- Vermeiden Sie die Gefahr eines Brandes, indem Sie die Möbel nicht in der Nähe von Zündquellen oder heißen Gegenständen aufstellen
- Nicht auf das Bett springen

Français

IMPORTANT ! CONSERVER POUR RÉFÉRENCE ULTÉRIEURE : LIRE ATTENTIVEMENT

- Le montage doit être effectué par un adulte. Le montage doit être vérifié par un adulte avant Utilisation
- ATTENTION ! Tenir les vis, les petites pièces et les sachets en plastique hors de portée des enfants
- Identifiez correctement toutes les pièces avant de les assembler
- N'utilisez jamais votre article si l'une de ses pièces est cassée ou manquante
- En cas de problème, veuillez contacter notre service après-vente
- Les instructions du fabricant doivent être respectées à tout moment
- Entretien : nettoyer avec un chiffon doux et sec. En cas de taches plus importantes, frotter soigneusement avec une éponge non abrasive légèrement humide. légèrement humide et non Abrasive
- Évitez les risques d'incendie en ne plaçant pas les meubles à proximité de sources d'inflammation ou d'objets chauds
- Ne pas sauter sur le lit

Italiano

IMPORTANTE! CONSERVARE PER RIFERIMENTO FUTURO: LEGGERE ATTENTAMENTE

- Deve essere assemblato da un adulto. L'assemblaggio deve essere controllato da un adulto prima dell'uso
- **ATTENZIONE!** Tenere tutte le viti, le piccole parti e i sacchetti di plastica fuori dalla portata dei bambini
- Identificare correttamente tutte le parti prima dell'assemblaggio
- Non utilizzare mai l'articolo se alcune parti sono rotte o mancanti
- In caso di problemi, si prega di contattare il nostro Servizio Post Vendita
- Le istruzioni del produttore devono essere sempre seguite
- Cura: Pulire con un panno morbido e asciutto. In caso di macchie più estese, strofinare accuratamente con una spugna leggermente umida e non abrasiva
- Evitare il rischio di incendio, non collocando i mobili vicino a fonti di accensione o a oggetti caldi
- Non saltare sul letto

Español





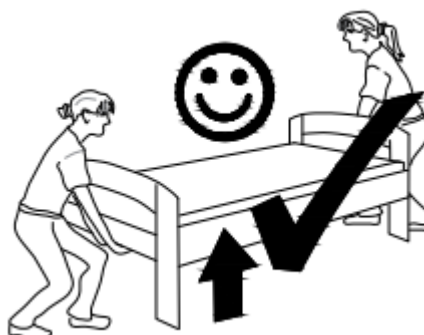
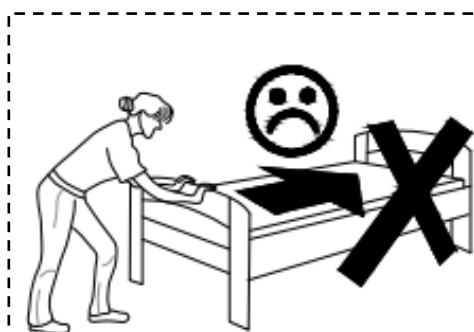

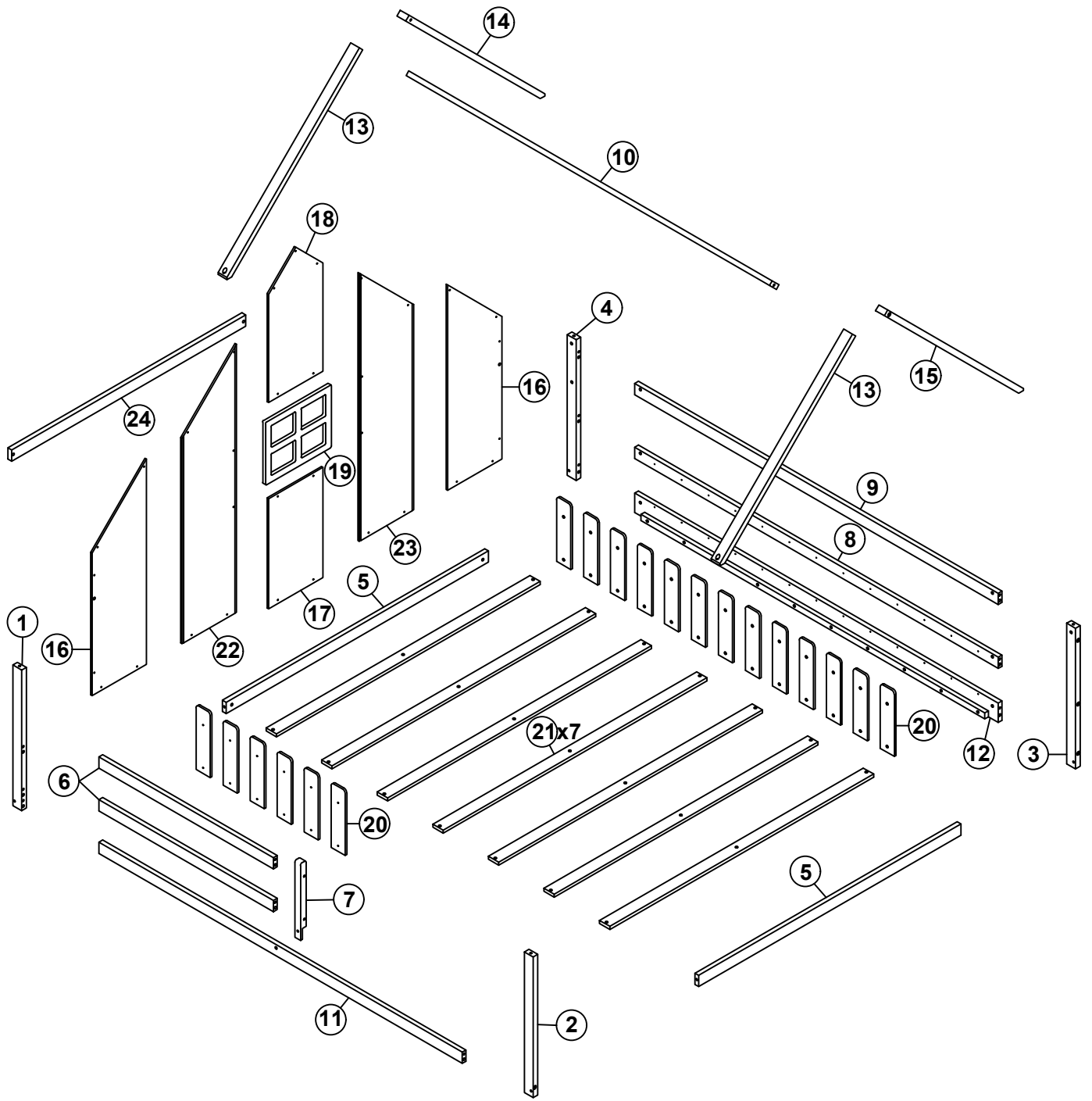

¡ IMPORTANTE ! CONSERVELO PARA FUTURAS CONSULTAS: LEA ATENTAMENTE

- Debe ser montado por un adulto. El montaje debe ser comprobado por un adulto antes del uso
- ADVERTENCIA Mantenga todos los tornillos, piezas pequeñas y bolsas de plástico fuera del alcance de los niños.
- Identifique correctamente todas las piezas antes de montarlas
 - Nunca utilice su artículo si alguna de sus piezas está rota o falta
 - Si surge algún problema, póngase en contacto con nuestro Servicio Postventa
 - Las instrucciones del fabricante deben seguirse en todo momento
 - Cuidado: Limpiar con un paño suave y seco. En caso de manchas más grandes, frote cuidadosamente con una esponja no abrasiva ligeramente humedecida.
 - Evite el riesgo de incendio no colocando los muebles cerca de fuentes de ignición u objetos calientes.
 - No saltar sobre la cama.







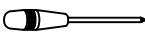



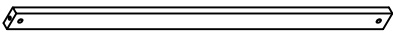

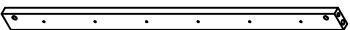

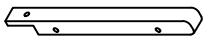
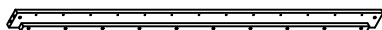
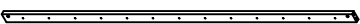
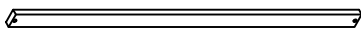

HARDWARE LIST (WF322721)

A	Ø4x30		14PCS	F	1/4x55		4PCS
B	Ø4x20		71PCS	G	1/4x25		1PC
C	1/4x90		12PCS	H	Ø10x40		12PCS
D	1/4x75		2PCS	I	4x58		1PC
E	1/4x65		8PCS	Phillip head screw Not include			

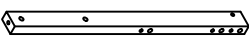
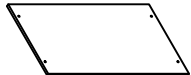
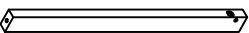
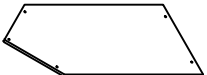
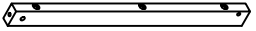
WF322720

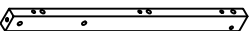
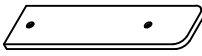
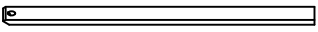
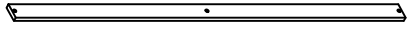
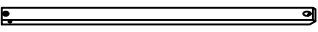
5	 Headboard panel	2pcs	10	 Roof crossbar	1pc
6	 Front guard rails	2pcs	11	 Side rails	1pc
7	 Support guard rails	1pc	12	 Side rails	1pc
8	 Back crossbar	1pc	24	 Headboard panel	1pc
9	 Back crossbar	1pc			

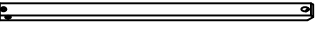

WF322721(Hardware in this SKU)

1	Leg 	1pc	17	Headboard panel 	1pc
2	Leg 	1pc	18	Headboard panel 	1pc
3	Leg 	1pc	19	Window panel 	1pc
4	Leg 	1pc	20	Headboard leg 	19pcs
13	Roof left & right front crossbar 	2pcs	21	Slats 	7pcs
14	Roof left back crossbar 	1pc	22	Headboard panel 	1pc
15	Roof right back crossbar 	1pc	23	Headboard panel 	1pc
16	Headboard panel 	2pcs			

DE: Vor dem Einbau die Schrauben in die Löcher stecken und festziehen, aber nicht bis 100%, 70% bis 80% anziehen reicht aus. Schließlich, nachdem alle Schrauben installiert sind, ziehen Sie alle Schrauben auf 100%. Wenn Sie auf diese Probleme stoßen, wie z. B. Fehlausrichtung der Löcher oder Unfähigkeit, bestimmte Teile zu installieren, überprüfen Sie bitte, ob die Schrauben korrekt verwendet werden und passen Sie die Dichtigkeit der Schrauben an.

UK: Before installation, insert the screws into the holes and tighten them, but do not tighten them to 100%, 70% to 80% is sufficient. Finally, after all screws are installed, tighten all screws to 100%. If you encounter these issues, such as if the holes cannot be aligned or some parts cannot be installed, please check if the screws are used correctly and adjust the tightness of the screws.





FR: Insérer la vis dans le trou avant la fin de l'assemblage, serrer la vis, mais ne pas serrer à 100%, 70% ~ 80% est correct. Enfin, une fois que toutes les vis sont bien serrées, toutes les vis sont serrées à 100%. Si vous rencontrez ces problèmes, par exemple si les trous ne sont pas alignés ou si certaines pièces ne peuvent pas être montées, vérifiez que les vis sont utilisées correctement et Ajustez leur serrage.

A	Ø4x30		14PCS	B	Ø4x20		71PCS
----------	-------	---	-------	----------	-------	---	-------

DE: Bitte beachten Sie, dass die Formen der Schrauben A und B ähnlich sind. Bitte installieren Sie entsprechend der Anleitung und unterscheiden Sie sie!

UK: Please note that the shapes of screws A and B are similar. Please install according to the instructions and distinguish them!

FR: Notez que les vis A et B ont des formes similaires. Veuillez les installer en suivant les instructions pour les séparer!

C	1/4x90		12PCS	E	1/4x65		8PCS
D	1/4x75		2PCS	F	1/4x55		4PCS

DE: Bitte beachten Sie, dass die Formen der Schrauben C und D und E und F ähnlich sind. Bitte installieren Sie entsprechend der Anleitung und unterscheiden Sie sie!

UK: Please note that the shapes of screws C and D and E and F are similar. Please install according to the instructions and distinguish them!

FR: Notez que les vis C et D et E et F ont des formes similaires. Veuillez les installer en suivant les instructions pour les séparer!

1

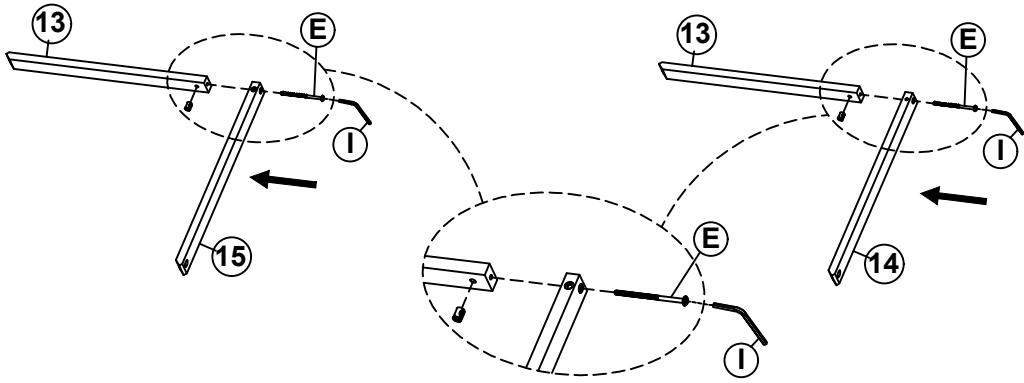

1/4x75

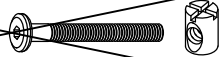

1/4x55

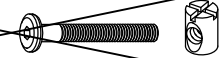

E

1/4x65



2PCS

I

4x58

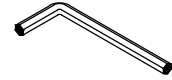

1PC

2

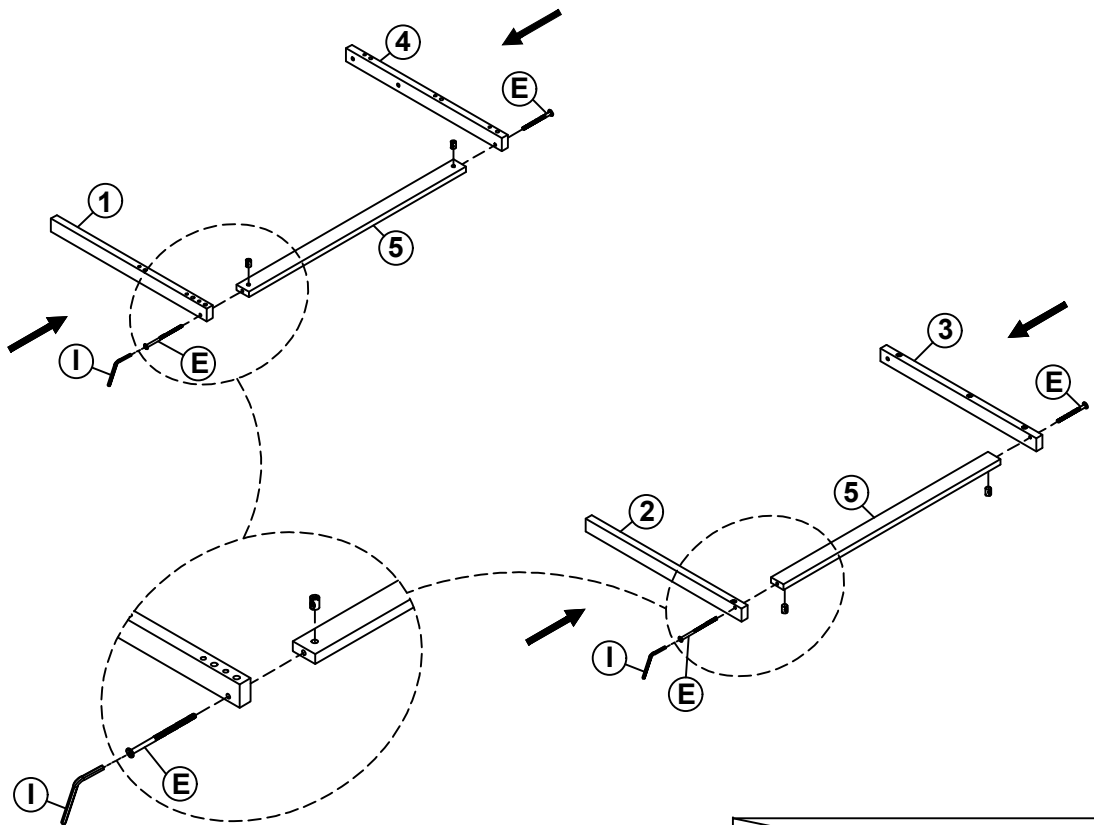

1/4x75

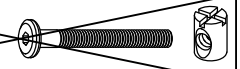

1/4x55

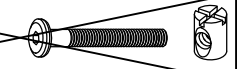

E

1/4x65



4PCS

I

4x58

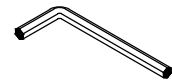

1PC

3

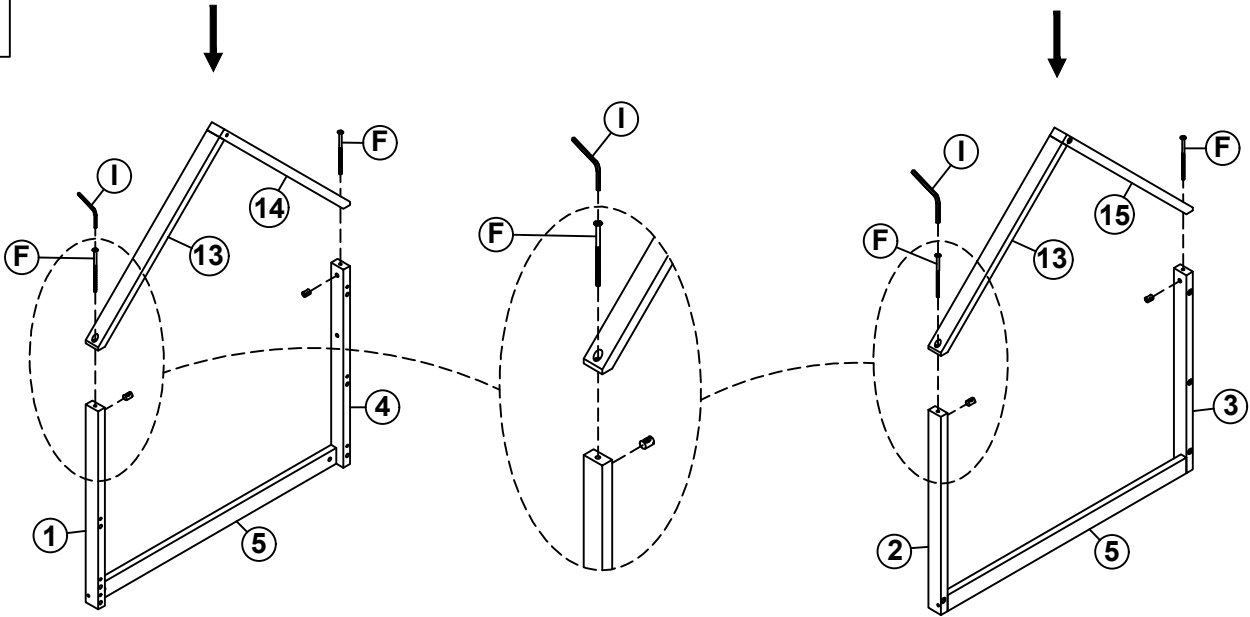

1/4x65

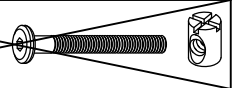

F	1/4x55		4PCS	I	4x58		1PC
----------	--------	--	------	----------	------	--	-----

4

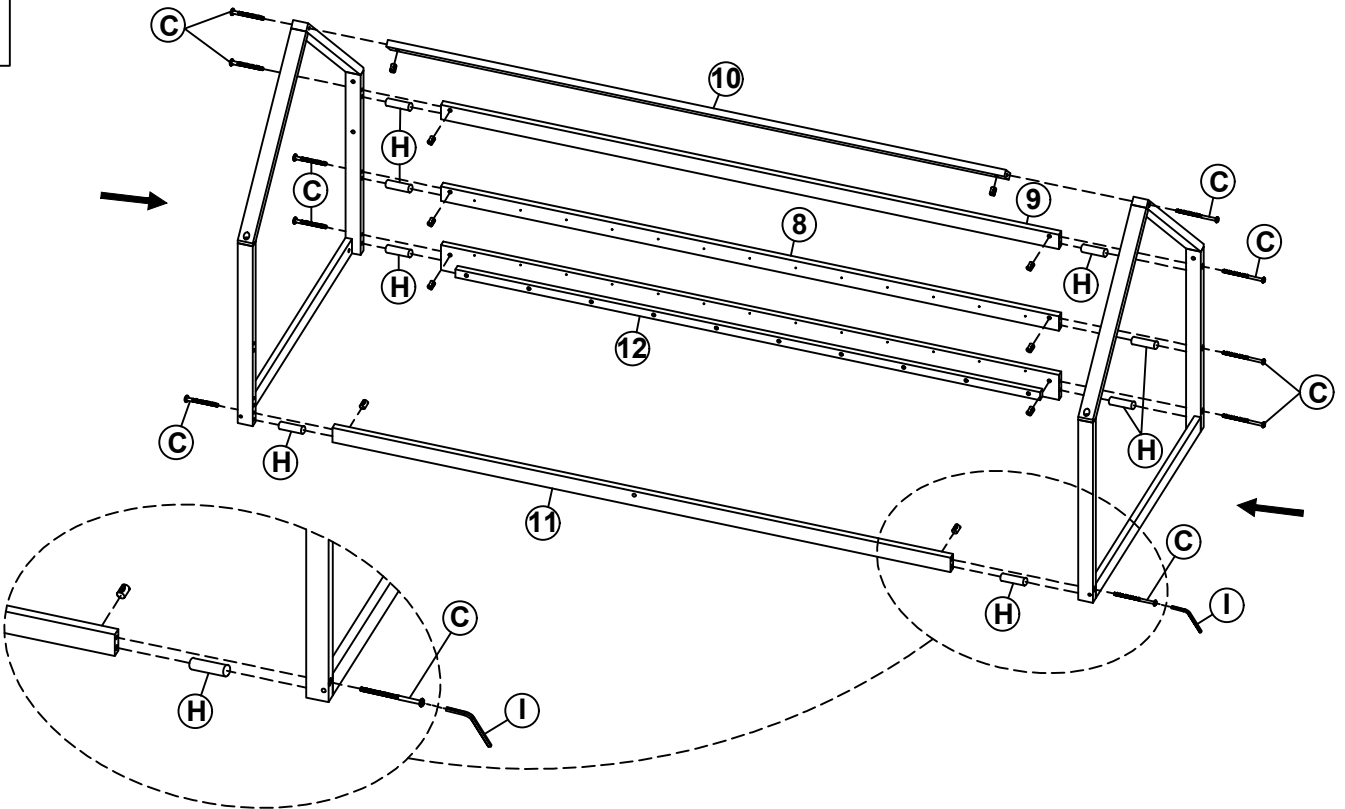

H	Ø10x40		8PCS				
C	1/4x90		10PCS	I	4x58		1PC

5

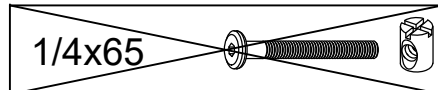
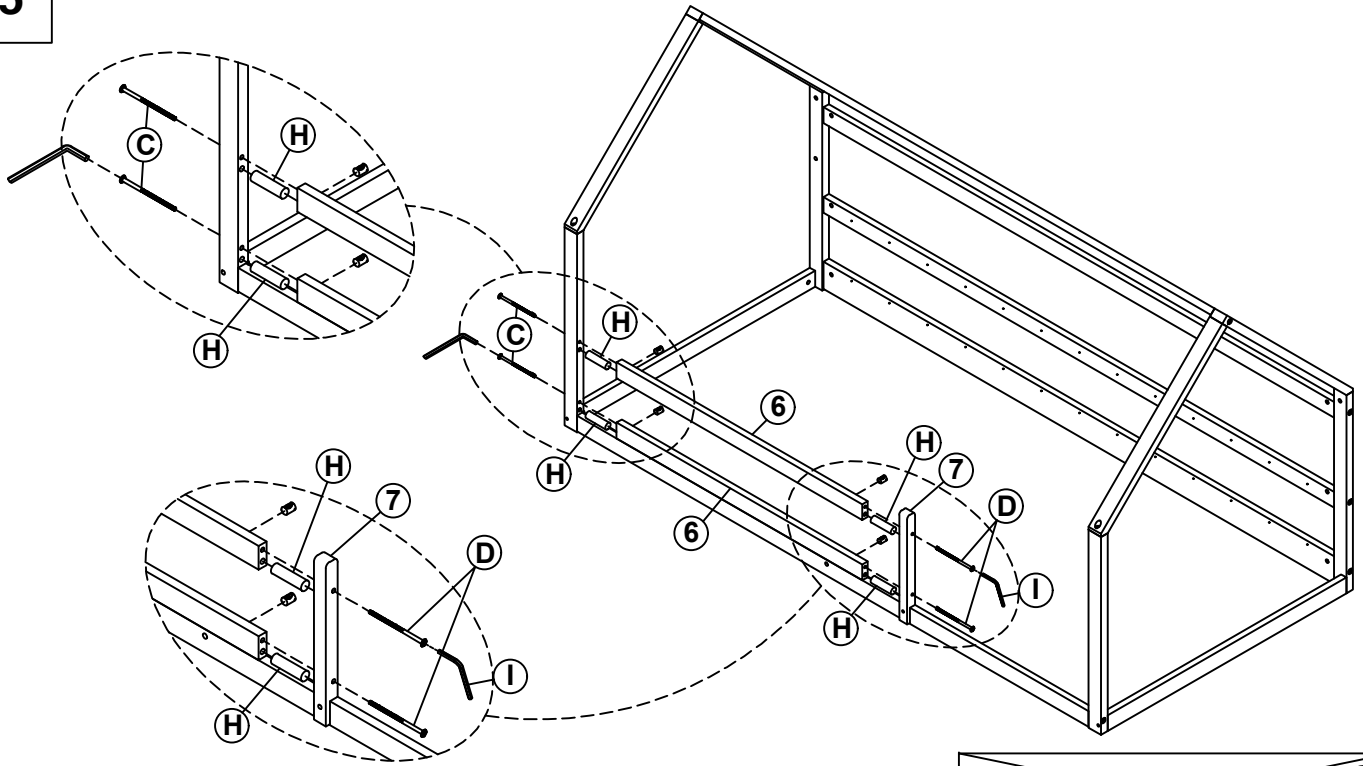

C	1/4x90			2PCS	H	Ø10x40		4PCS
D	1/4x75			2PCS	I	4x58		1PC

6

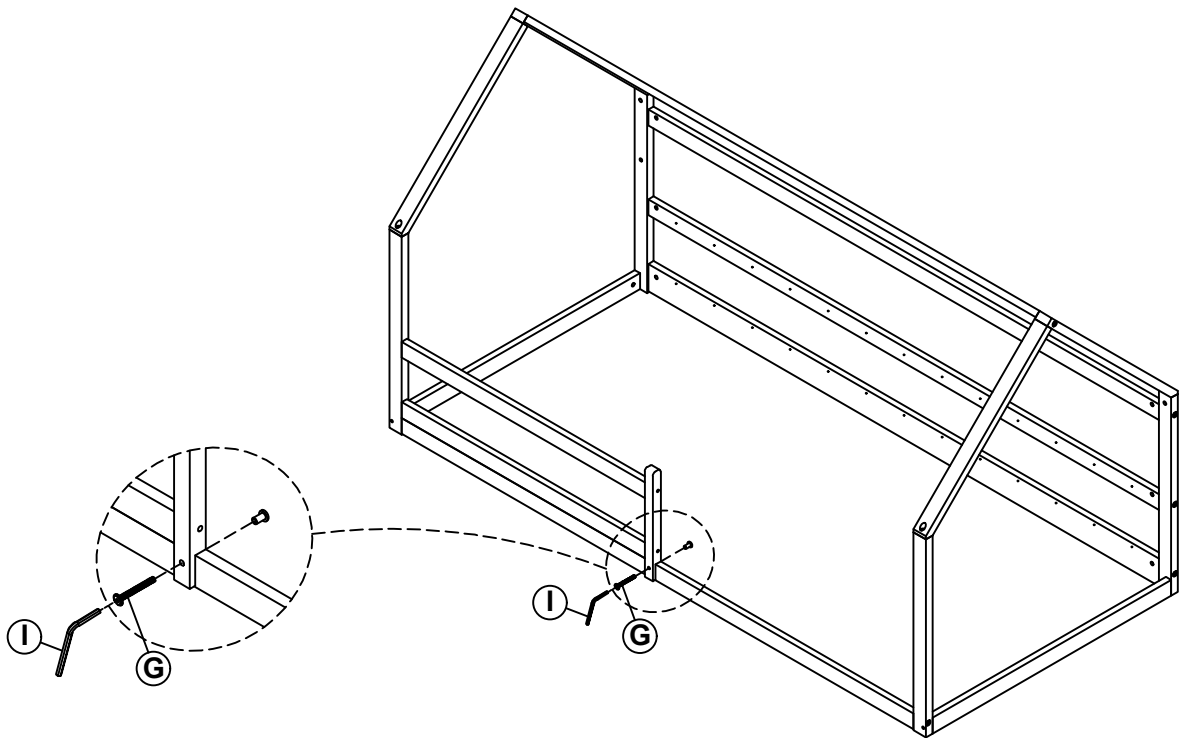

G	1/4x25			1PC	I	4x58		1PC
----------	--------	--	--	-----	----------	------	--	-----

7

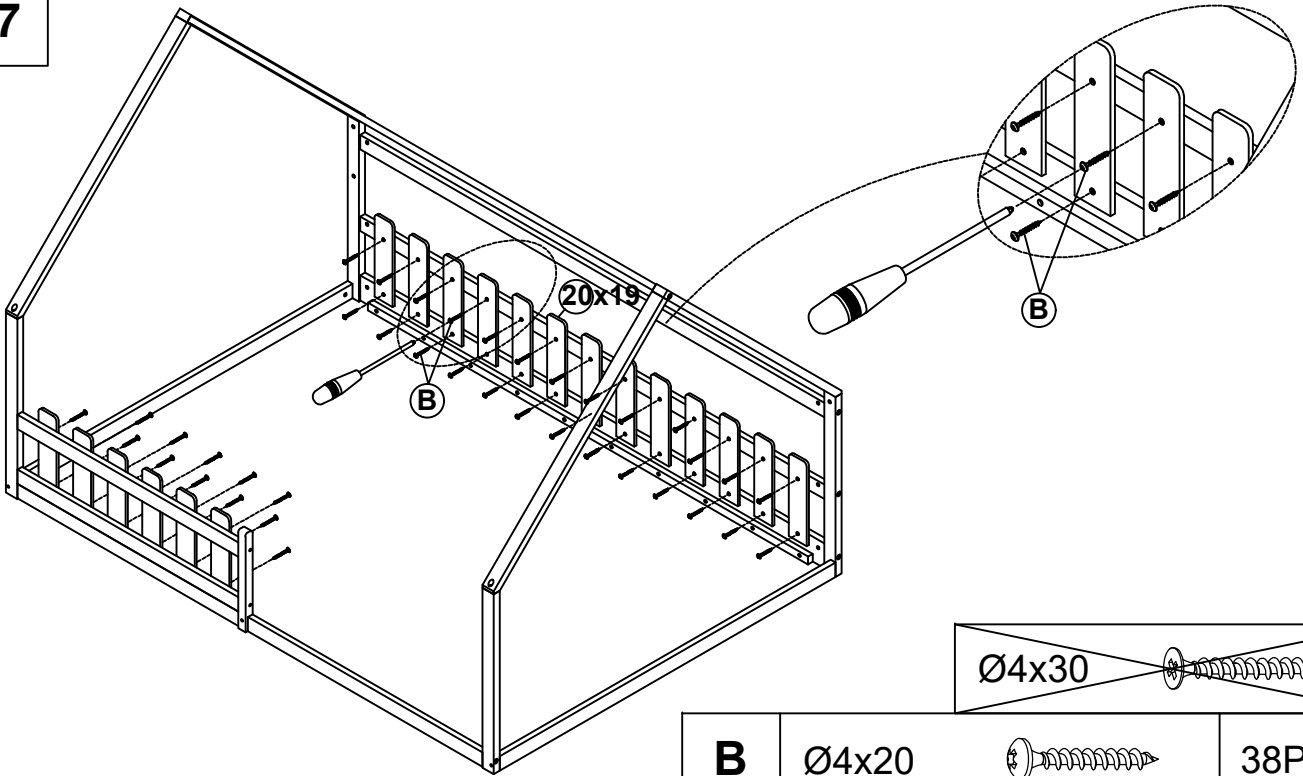

B

Ø4x20



38PCS

Ø4x30

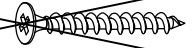

8

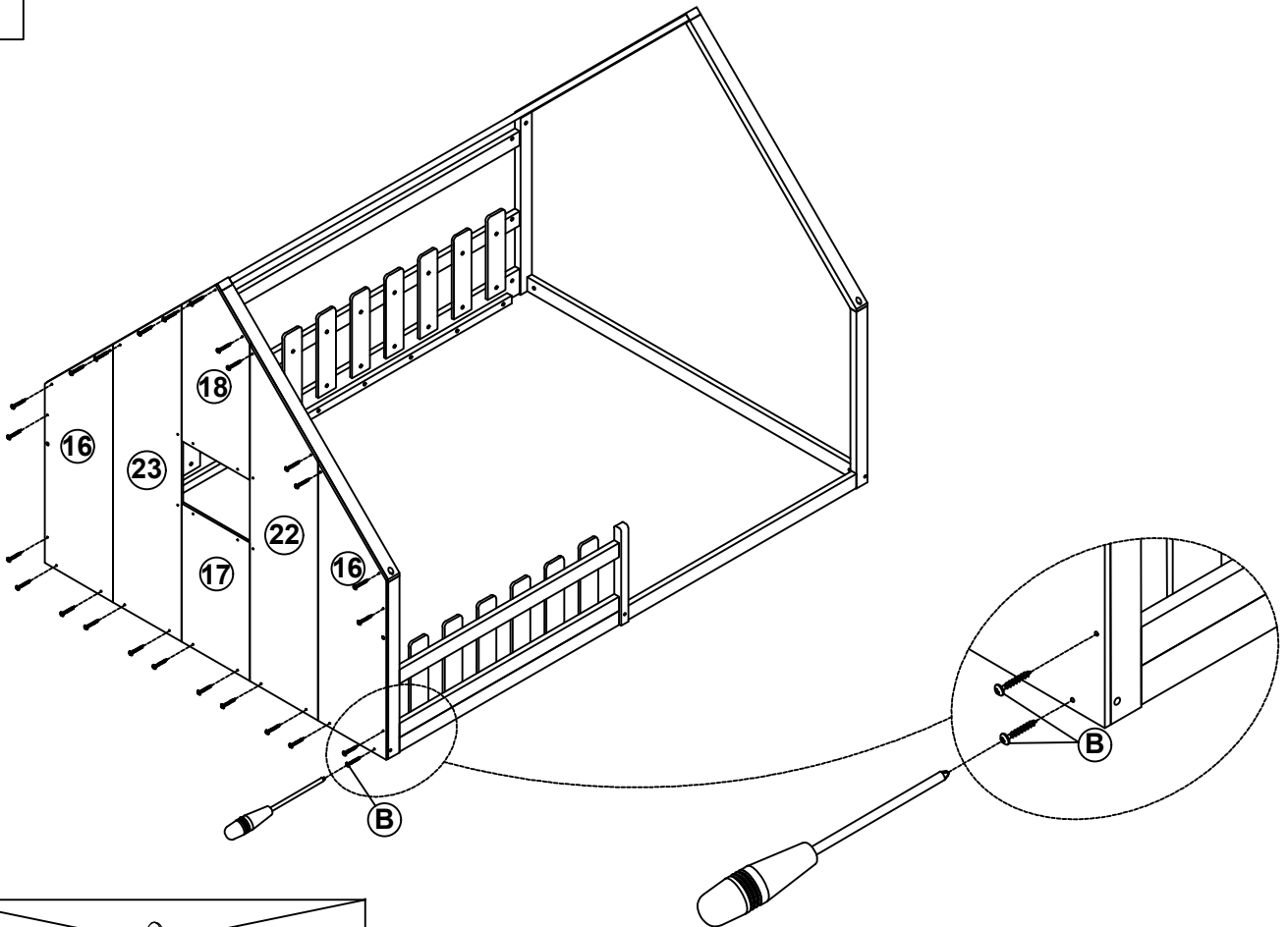

B

Ø4x20



25PCS

Ø4x30



9

View form the back

View form the front

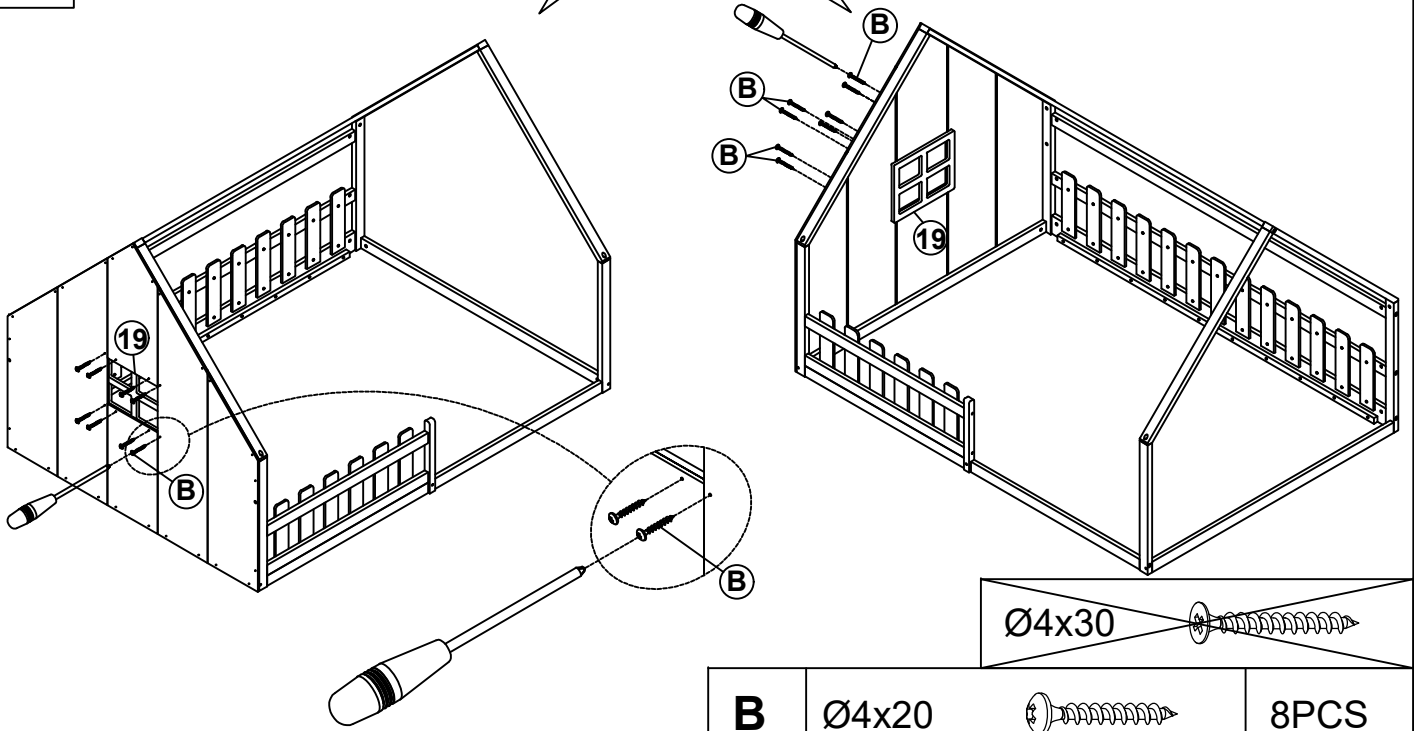

B	Ø4x20		8PCS
----------	-------	---	------

10

View form the back

View form the front

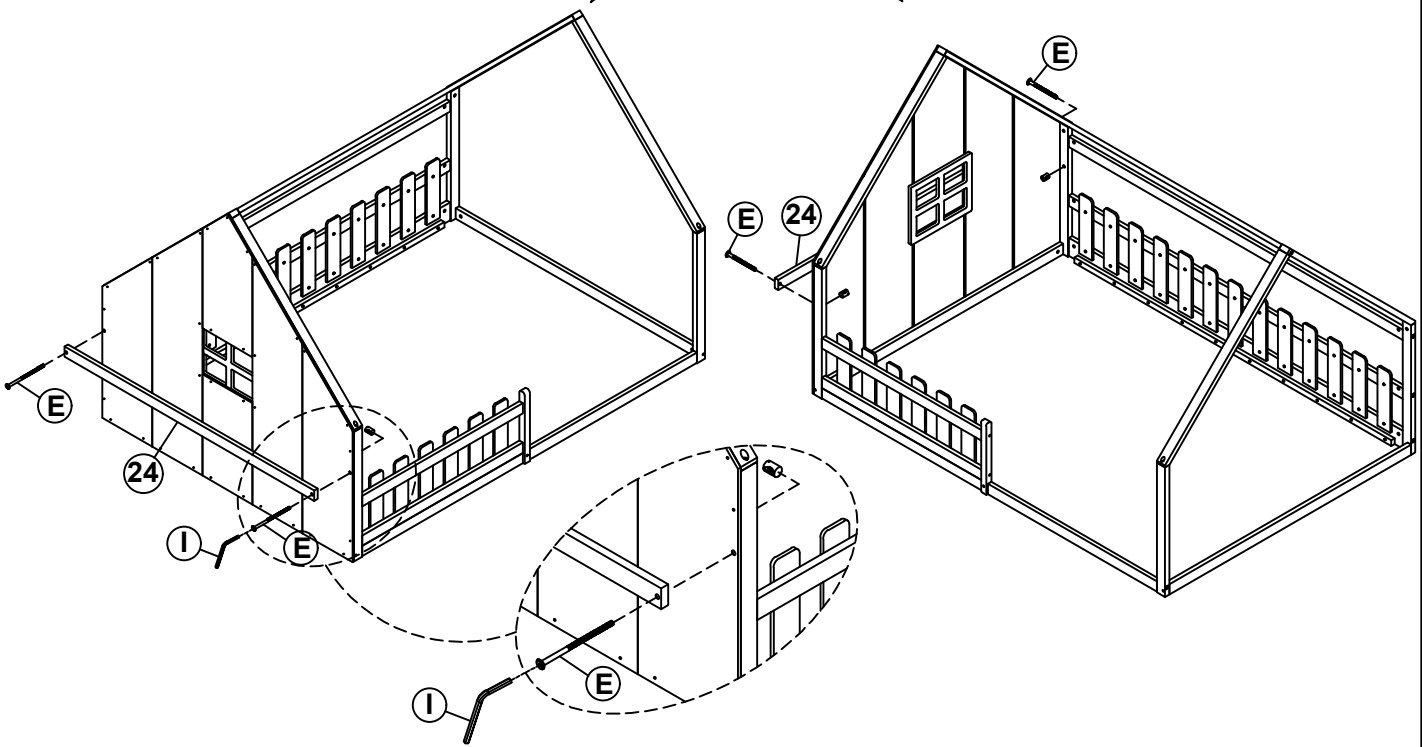

E	1/4x65		2PCS	I	4x58		1PC
----------	--------	---	------	----------	------	---	-----

First attach 2pcs part 21 to the front and end of the frame between headboard. Then attach the remaining part 21 equidistantly between headboard

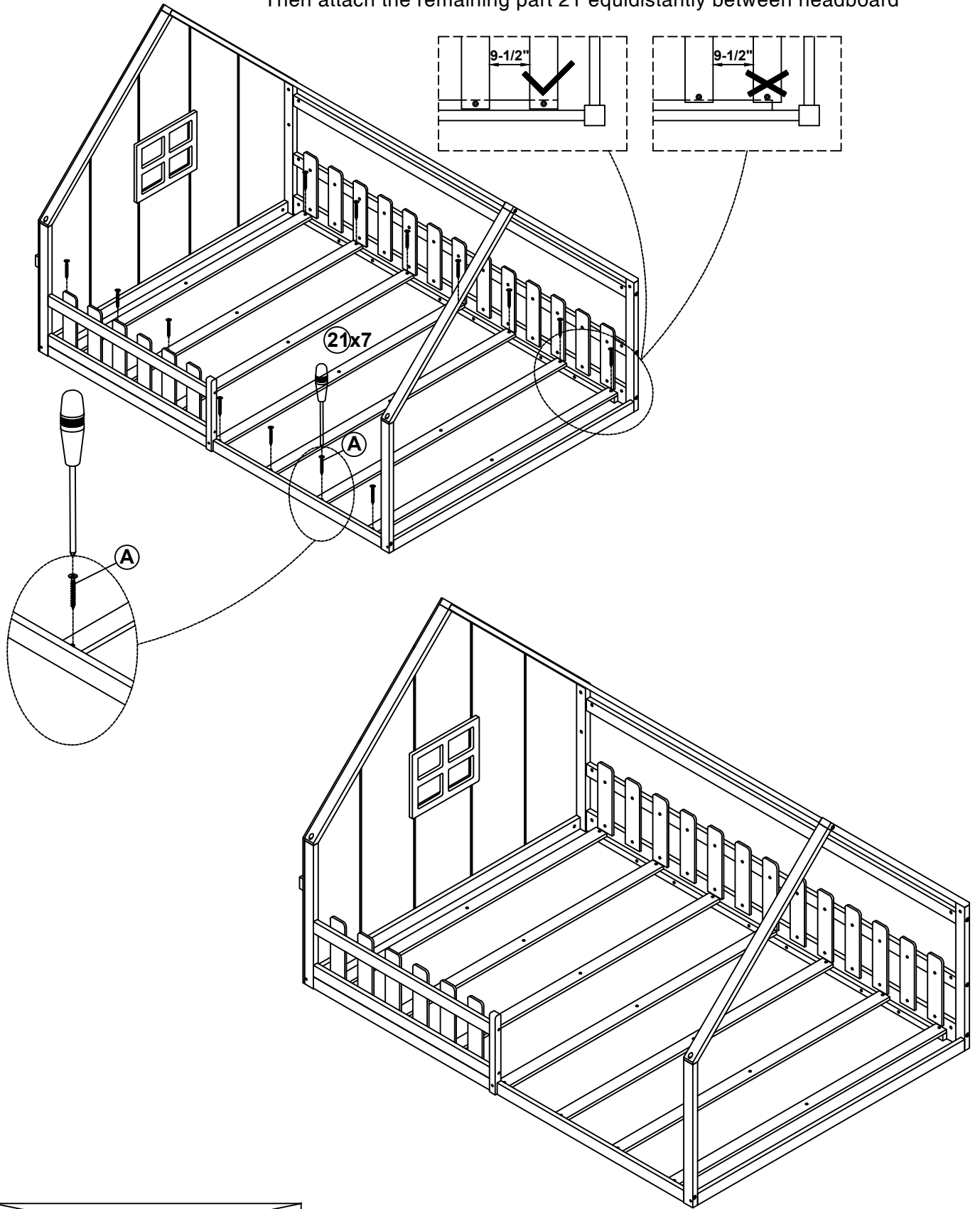

Ø4x20

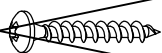

A

Ø4x30



14PCS

Finished