

Installation sanleitung

Installation Instruction

Instruction d'installation

SKU:N623P207278 / N623P207279

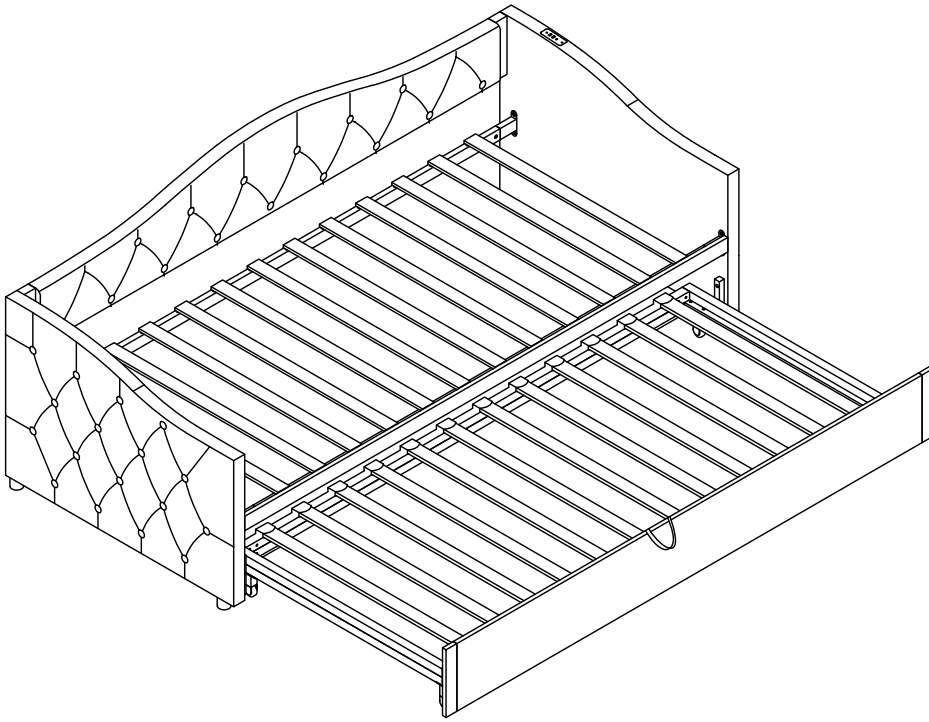

Unser Produkt wird Ihnen in 2 Paketen geliefert. Die Lieferzeiten dieser 2 Pakete können abweichen, bitte haben Sie etwas Geduld und vielen Dank für Ihr Verständnis.

Our product will be delivered to you in 2 packages. The delivery times of these 2 packages may differ, please be patient and thank you for your understanding.

Notre produit vous sera livré en 2 colis. Les délais de livraison de ces 2 colis peuvent différer, soyez patient et merci pour votre compréhension.



English

IMPORTANT ! KEEP FOR FUTURE REFERENCE : READ CAREFULLY

- To be assembled by an adult. Assembly must be checked by an adult before use
- WARNING ! Keep all screws, small parts and plastic bags out of the reach of children
- Properly identify all parts before assembling
- Never use your item if any of its parts are broken or missing
- Should any problems arise, please contact our After Sales Service
- Manufacturer's instructions shall be followed at all times
- Care: Clean with a soft, dry cloth. In case of larger stains, carefully rub with a slightly damp, non-abrasive sponge
- Avoid the risk of fire by not placing furniture near sources of ignition or hot items
- Do not jump on the bed

Deutsch

WICHTIG ! ZUM SPÄTEREN NACHSCHLAGEN AUFBEWAHREN: SORGFÄLTIG LESEN

- Muss von einem Erwachsenen zusammengebaut werden. Der Zusammenbau muss vor dem Gebrauch von einem Erwachsenen überprüft werden
- WARNUNG! Bewahren Sie alle Schrauben, Kleinteile und Plastikbeutel außerhalb der Reichweite von Kindern auf
- Kennzeichnen Sie vor dem Zusammenbau alle Teile richtig
- Benutzen Sie Ihren Artikel niemals, wenn Teile gebrochen sind oder fehlen
- Sollten Probleme auftreten, wenden Sie sich bitte an unseren Kundendienst
- Die Anweisungen des Herstellers sind stets zu befolgen
- Pflege: Mit einem weichen, trockenen Tuch reinigen. Bei größeren Flecken vorsichtig mit einem leicht feuchten, nicht scheuernden Schwamm abreiben. nicht scheuernden Schwamm
- Vermeiden Sie die Gefahr eines Brandes, indem Sie die Möbel nicht in der Nähe von Zündquellen oder heißen Gegenständen aufstellen
- Nicht auf das Bett springen

Français

IMPORTANT ! CONSERVER POUR RÉFÉRENCE ULTÉRIEURE : LIRE ATTENTIVEMENT

- Le montage doit être effectué par un adulte. Le montage doit être vérifié par un adulte avant Utilisation
- ATTENTION ! Tenir les vis, les petites pièces et les sachets en plastique hors de portée des enfants
- Identifiez correctement toutes les pièces avant de les assembler
- N'utilisez jamais votre article si l'une de ses pièces est cassée ou manquante
- En cas de problème, veuillez contacter notre service après-vente
- Les instructions du fabricant doivent être respectées à tout moment
- Entretien : nettoyer avec un chiffon doux et sec. En cas de taches plus importantes, frotter soigneusement avec une éponge non abrasive légèrement humide. légèrement humide et non Abrasive
- Évitez les risques d'incendie en ne plaçant pas les meubles à proximité de sources d'inflammation ou d'objets chauds
- Ne pas sauter sur le lit

Italiano

IMPORTANTE! CONSERVARE PER RIFERIMENTO FUTURO: LEGGERE ATTENTAMENTE

- Deve essere assemblato da un adulto. L'assemblaggio deve essere controllato da un adulto prima dell'uso
- **ATTENZIONE!** Tenere tutte le viti, le piccole parti e i sacchetti di plastica fuori dalla portata dei bambini
- Identificare correttamente tutte le parti prima dell'assemblaggio
- Non utilizzare mai l'articolo se alcune parti sono rotte o mancanti
- In caso di problemi, si prega di contattare il nostro Servizio Post Vendita
- Le istruzioni del produttore devono essere sempre seguite
- Cura: Pulire con un panno morbido e asciutto. In caso di macchie più estese, strofinare accuratamente con una spugna leggermente umida e nonspugna leggermente umida e non abrasiva
- Evitare il rischio di incendio, non collocando i mobili vicino a fonti di accensione o a oggetti caldi
- Non saltare sul letto

Español

¡ IMPORTANTE ! CONSERVELO PARA FUTURAS CONSULTAS: LEA ATENTAMENTE

- Debe ser montado por un adulto. El montaje debe ser comprobado por un adulto antes del uso
- ADVERTENCIA Mantenga todos los tornillos, piezas pequeñas y bolsas de plástico fuera del alcance de los niños.
- Identifique correctamente todas las piezas antes de montarlas
 - Nunca utilice su artículo si alguna de sus piezas está rota o falta
 - Si surge algún problema, póngase en contacto con nuestro Servicio Postventa
 - Las instrucciones del fabricante deben seguirse en todo momento
 - Cuidado: Limpiar con un paño suave y seco. En caso de manchas más grandes, frote cuidadosamente con una esponja no abrasiva ligeramente humedecida.
 - Evite el riesgo de incendio no colocando los muebles cerca de fuentes de ignición u objetos calientes.
 - No saltar sobre la cama.

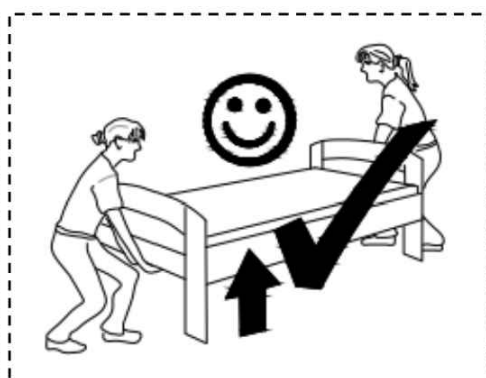
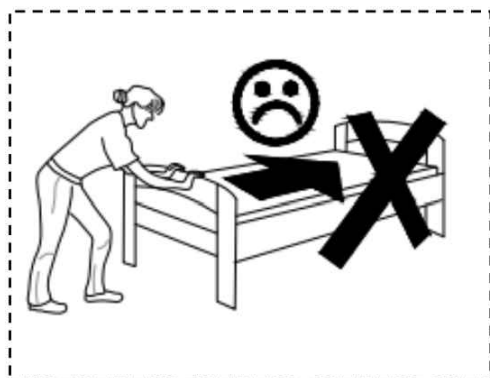



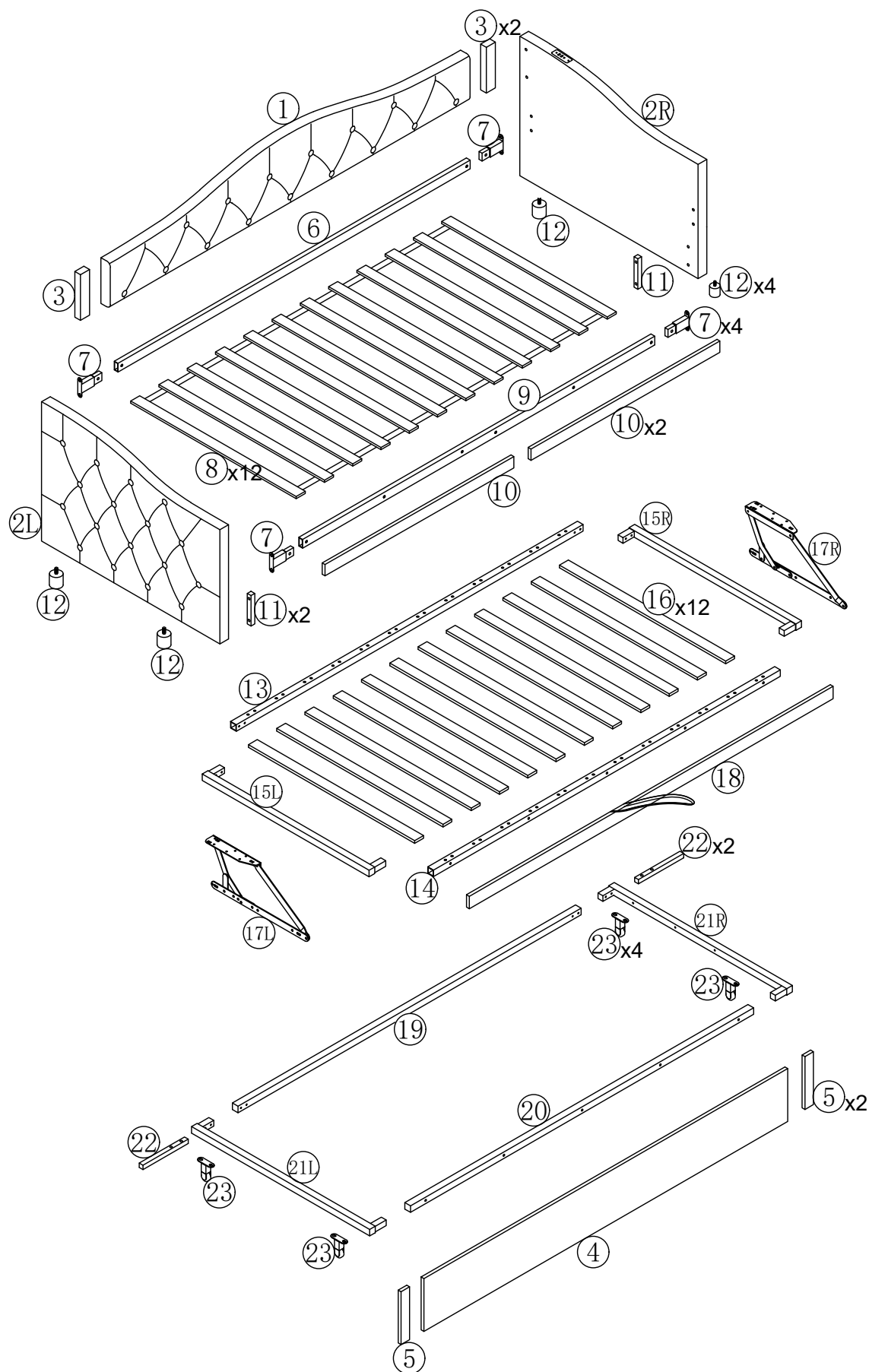

Stückliste

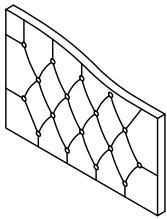
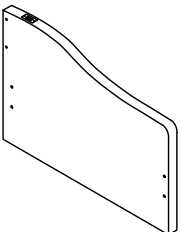

Liste der Einzelteile

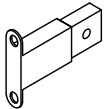
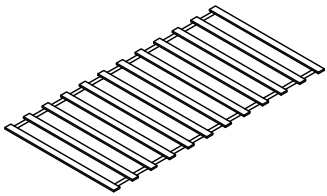
Hardwareliste+N623P207278

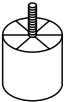
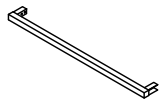
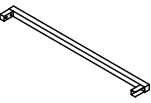
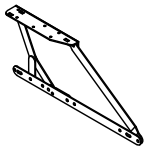
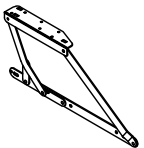
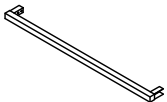
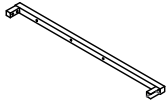
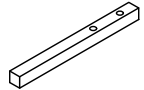
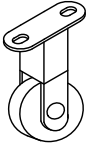
<p>②L x1</p>  <p>Armrest</p>	<p>②R x1</p>  <p>Armrest</p>	<p>③ x2</p>  <p>Side part of the backrest</p>
<p>⑤ x2</p>  <p>Bottom bed side panels</p>	<p>⑦ x4</p>  <p>Part of metal side bar</p>	<p>⑧ x12</p>  <p>Slats</p>
<p>⑪ x2</p>  <p>Vertical square tubes</p>	<p>⑫ x4</p>  <p>Legs</p>	<p>⑮L x1</p>  <p>Bottom bed top cross bar</p>
<p>⑮R x1</p>  <p>Bottom bed top cross bar</p>	<p>⑰L x1</p>  <p>Lifting system</p>	<p>⑰R x1</p>  <p>Lifting system</p>
<p>⑳L x1</p>  <p>Bottom bed base cross bar</p>	<p>⑳R x1</p>  <p>Bottom bed base cross bar</p>	<p>㉑ x2</p>  <p>Transverse square tube</p>
<p>㉓ x4</p>  <p>Wheel</p>		





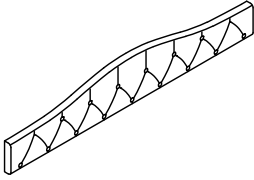
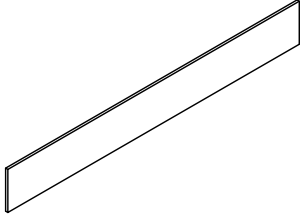
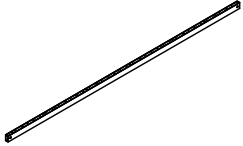
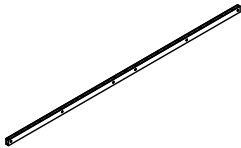
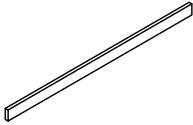
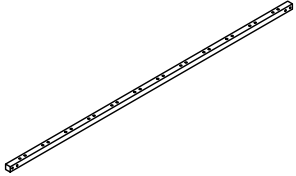
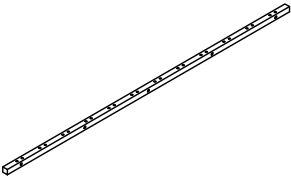
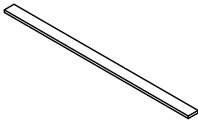
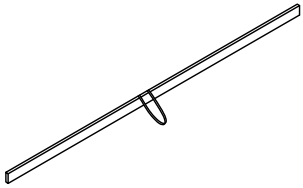
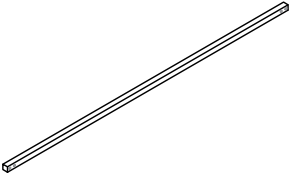
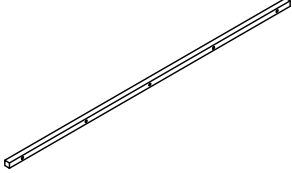



Liste der Einzelteile

N623P207279

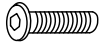
<p>① x1</p>  <p>Back rest</p>	<p>④ x1</p>  <p>Bottom bed base board</p>	<p>⑥ x1</p>  <p>Metal side bar</p>
<p>⑨ x1</p>  <p>Metal side bar</p>	<p>⑩ x2</p>  <p>Side rail</p>	<p>⑬ x1</p>  <p>Bottom bed top side bar</p>
<p>⑭ x1</p>  <p>Bottom bed top side bar</p>	<p>⑯ x12</p>  <p>Slats</p>	<p>⑱ x1</p>  <p>Bottom bed top board</p>
<p>⑲ x1</p>  <p>Bottom bed base side bar</p>	<p>⑳ x1</p>  <p>Bottom bed base side bar</p>	

Hardwareliste

N623P207278

<p>A x1</p>  <p>Allen Key</p>	<p>B x10</p>  <p>M8x45mm</p> <p>Bolts</p>	<p>C x16</p>  <p>M8x35mm</p> <p>Bolts</p>
<p>D x36</p>  <p>M8x18mm</p> <p>Bolts</p>	<p>E x26</p>  <p>M6x15mm</p> <p>Bolts</p>	<p>F x2</p>  <p>Six hole iron</p>
<p>G x2</p>  <p>Four hole iron</p>	<p>H x1</p>  <p>Spanner</p>	<p>I x2</p>  <p>Nuts</p>
<p>J x24</p>  <p>End slats cap</p>		

DE:Bitte beachten Sie, dass die Formen der Schrauben B und C und D ähnlich sind. Bitte installieren Sie entsprechend der Anleitung und unterscheiden Sie sie!

UK:Please note that the shapes of screws B and C and D are similar. Please install according to the instructions and distinguish them!

FR:Notez que les vis B et C et D ont des formes similaires. Veuillez les installer en suivant les instructions pour les séparer!

DE: Vor dem Einbau die Schrauben in die Löcher stecken und festziehen, aber nicht bis 100%, 70% bis 80% anziehen reicht aus. Schließlich, nachdem alle Schrauben installiert sind, ziehen Sie alle Schrauben auf 100%.

Wenn Sie auf diese Probleme stoßen, wie z. B. Fehlausrichtung der Löcher oder Unfähigkeit, bestimmte Teile zu installieren, überprüfen Sie bitte, ob die Schrauben korrekt verwendet werden und passen Sie die Dichtigkeit der Schrauben an.

UK: Before installation, insert the screws into the holes and tighten them, but do not tighten them to 100%, 70% to 80% is sufficient. Finally, after all screws are installed, tighten all screws to 100%.

If you encounter these issues, such as if the holes cannot be aligned or some parts cannot be installed, please check if the screws are used correctly and adjust the tightness of the screws.

FR: Insérer la vis dans le trou avant la fin de l'assemblage, serrer la vis, mais ne pas serrer à 100%, 70% ~ 80% est correct. Enfin, une fois que toutes les vis sont bien serrées, toutes les vis sont serrées à 100%.

Si vous rencontrez ces problèmes, par exemple si les trous ne sont pas alignés ou si certaines pièces ne peuvent pas être montées, vérifiez que les vis sont utilisées correctement et Ajustez leur serrage.

Attention: Do not tighten the screws before completing the entire installation. If you have any difficulty with the installation process, please feel free to contact us.

Step 1 x2

Fix the legs ⑫ to the Armrest ② .

(Befestigen Sie die Beine ⑫ an der Armlehne ② .)

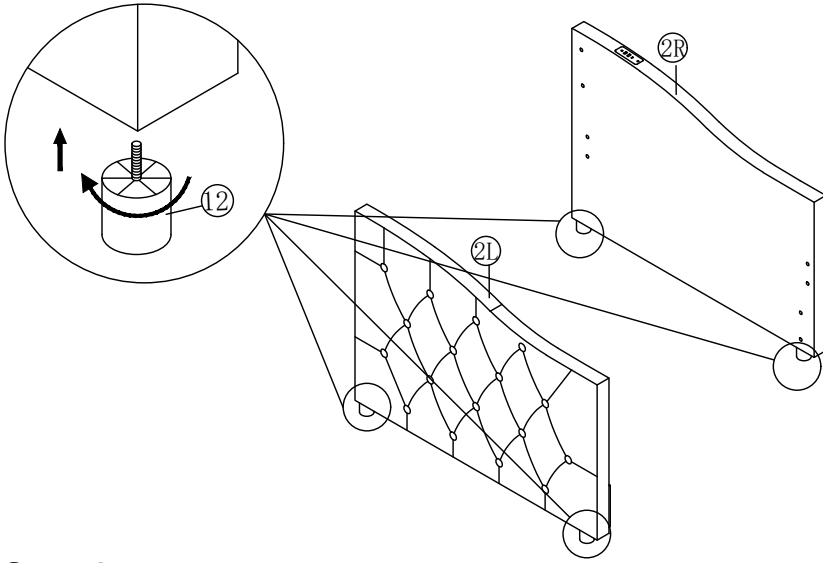



Step 2

Fix the Part of Vertical square tubes ① to Armrest ② with Bolts C by using Allen key A.

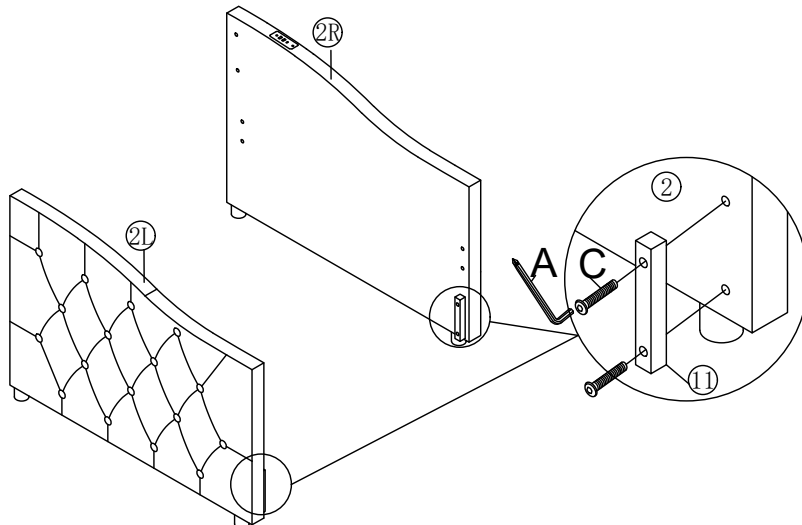
(Befestigen Sie den Vierkantröhr ① mit den Schrauben C und einem Inbusschlüssel A an der Armlehne ②.)







Allen Key 	C Bolts x 4  M8X35mm
--	---

Step 3

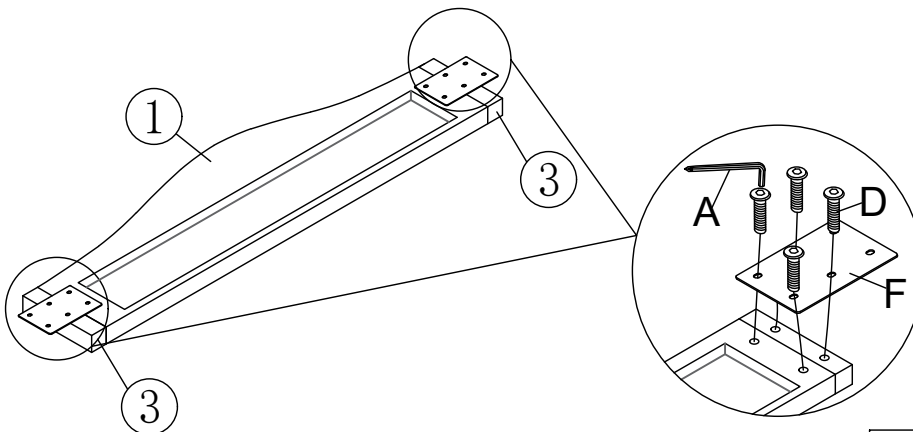
Fix the Backrest ① and side part of the Backrest ③ together with Six hole iron F and Bolts D by using Allen key A.

(Befestigen Sie die Rückenlehne ① und das Seitenteil der Rückenlehne ③ mit Sechslöchisen F und Bolzen D unter Verwendung eines Inbusschlüssels A.)





A Allen Key 	D Bolts x 8  M8X18mm	F Six hole iron x2 
--	---	---

Step 4

Fix the Armrest ② to the Backrest ① with Six hole iron F and Bolts D by using Allen key A.

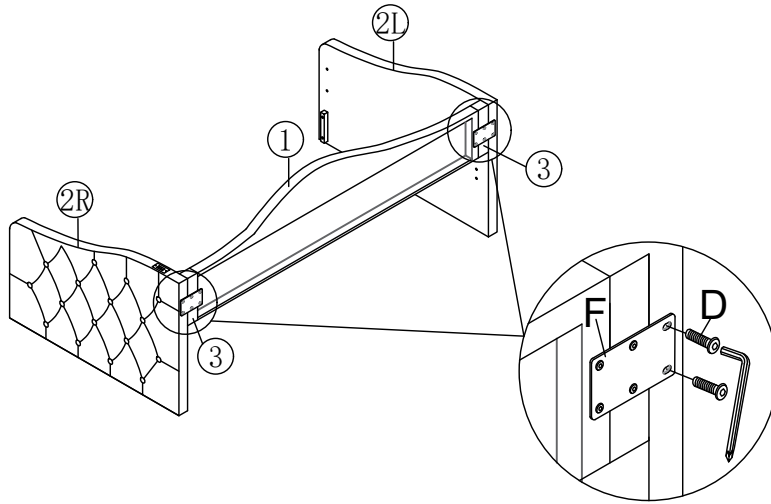
(Befestigen Sie die Armlehne ② mit Sechslöchern F und Bolzen D mithilfe eines Inbusschlüssels A an der Rückenlehne ①.)







Allen Key 	D Bolts x 4  M8X18mm
--	---

Step 5

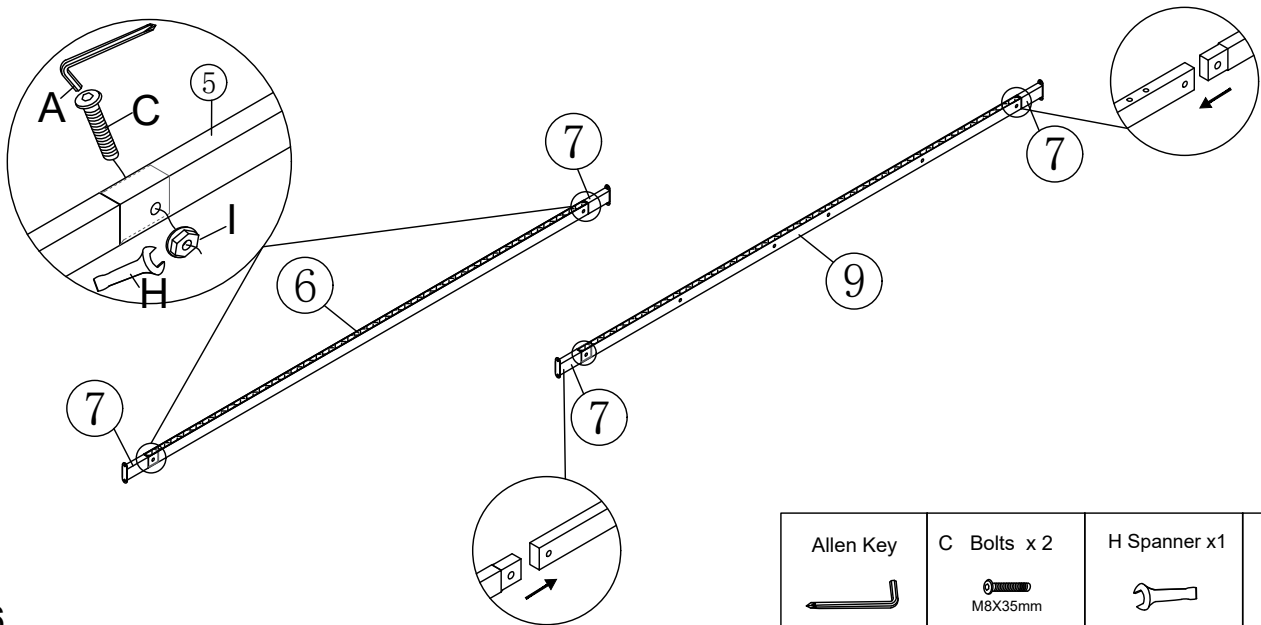
Put part of Metal side bar ⑦ to the Metal side bar ⑥ and ⑨. Please notice that only fix part of Metal side bar ⑦ and Metal side bar ⑥ together with Bolts C and Nuts I by using Allen key A and Spanner H.

(Setzen Sie einen Teil der Metallseitenstange ⑦ auf die Metallseitenstange ⑥ und ⑨. Bitte beachten Sie, dass nur ein Teil der Metallseitenleiste ⑦ und Metallseitenstange ⑥ zusammen mit Schrauben C und Muttern I mit Inbusschlüssel A und Schlüssel H.)





Allen Key 	C Bolts x 2  M8X35mm	H Spanner x1 	I Nuts x 2 
---	---	---	---

Step 6

Fix the Part of metal side bar ⑦ to Armrest ② with Bolts D by using Allen key A.

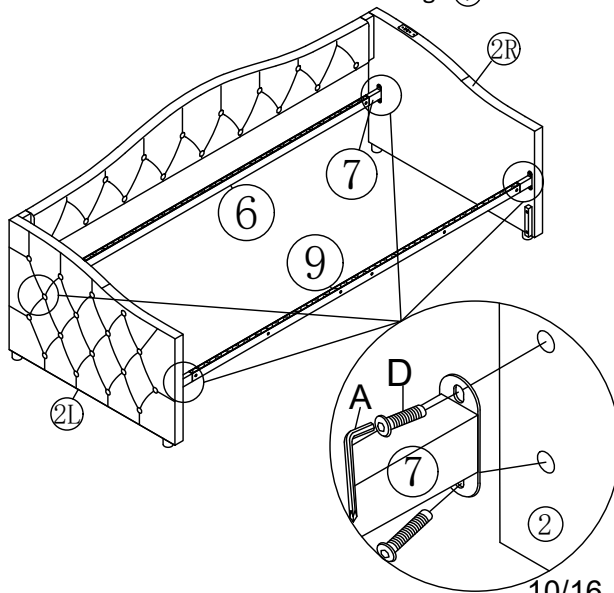
(Befestigen Sie den Teil der metallischen Seitenstange ⑦ mit den Schrauben D und einem Inbusschlüssel A an der Armlehne ②.)



Allen Key 	D Bolts x 8  M8X18mm
--	---

Step 7

Fix the Side rail ⑩ to the Metal side bar ⑨ with Bolts C by using Allen key A.

(Befestigen Sie die Seitenschiene ⑩ mit Schrauben C mit Inbusschlüssel A an der Metall-Seitenstange ⑨.)

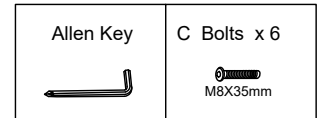
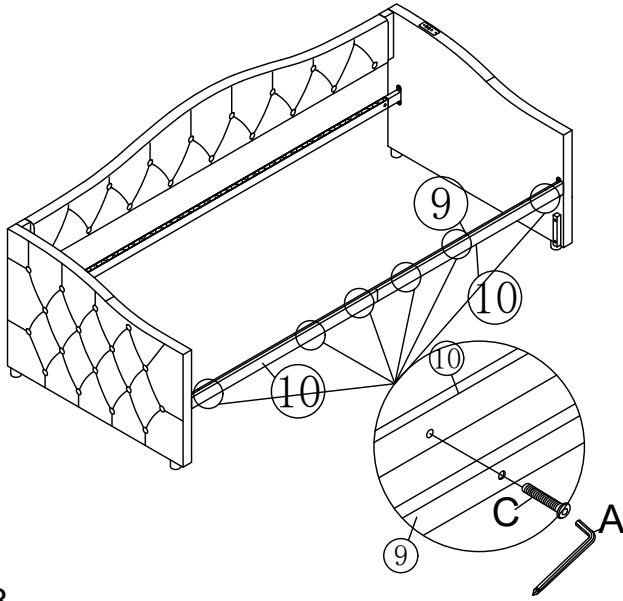

Step 8

Put the Slats ⑧ to the Metal side bar ⑥ and ⑨.

(Setzen Sie die Lamellen ⑧ auf die Metall Seitenleiste ⑥ und ⑨.)

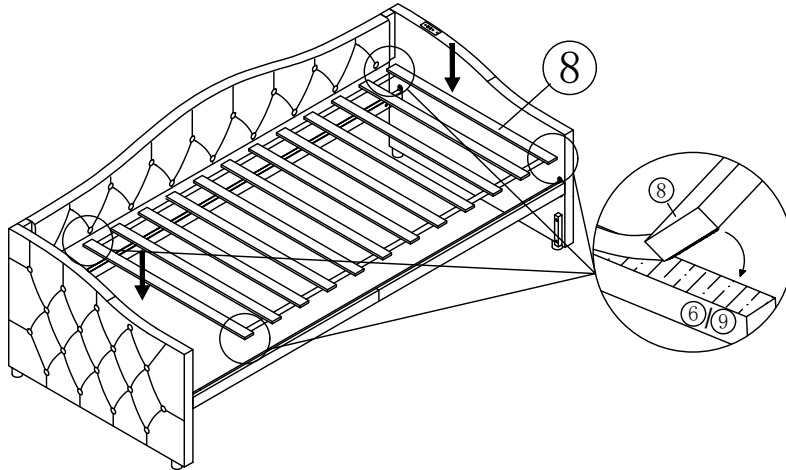

Step 9

Fix Bottom bed base side bar ⑲, ⑳ and Bottom bed base cross bar ㉑ together with Bolts E by using Allen key A.

(Befestigen Sie die unteren Seitenstreben ⑲ und ㉑ des Bettgestells und die unteren Querstreben ㉑ des Bettgestells zusammen mit den Bolzen E unter Verwendung eines Inbusschlüssels A.)

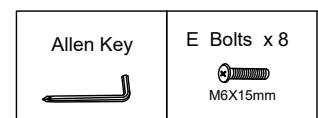
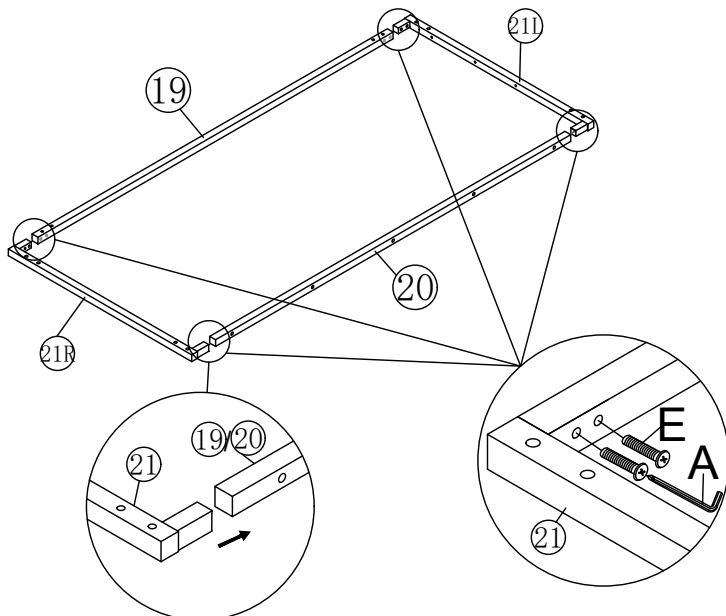

Step 10

Fix the Transverse square tubes ②② to the Bottom bed base side bar ①⑨ with Bolts C by using Allen key A.
(Befestigen Sie die Vierkantrohr ②② mit Schrauben C mit Inbusschlüssel A an der Seitenstange des unteren Bettsockels ①⑨.)

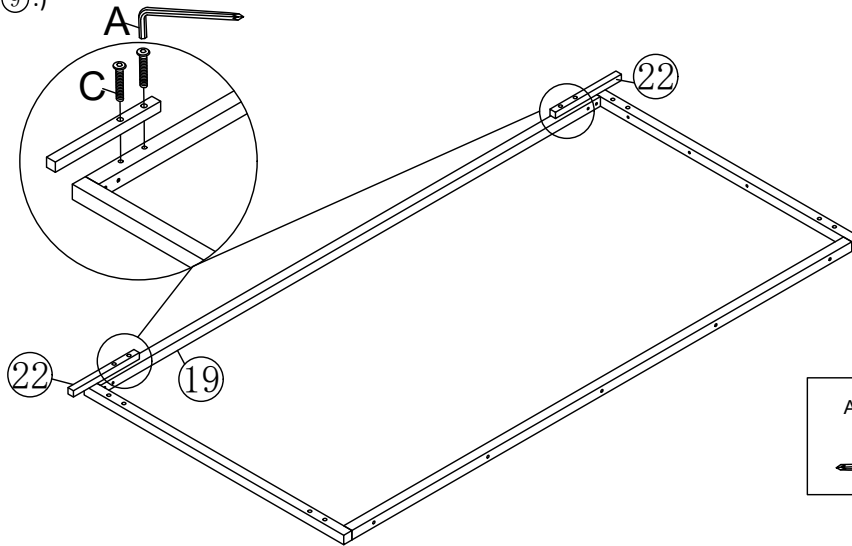

Step 11

Fix the Wheel ②③ to the Bottom bed base cross bar ②① with Bolts D by using Allen key A.
(Befestigen Sie das Rad ②③ mit den Schrauben D und einem Inbusschlüssel A an der Querstrebe ②① des unteren Bettgestells.)

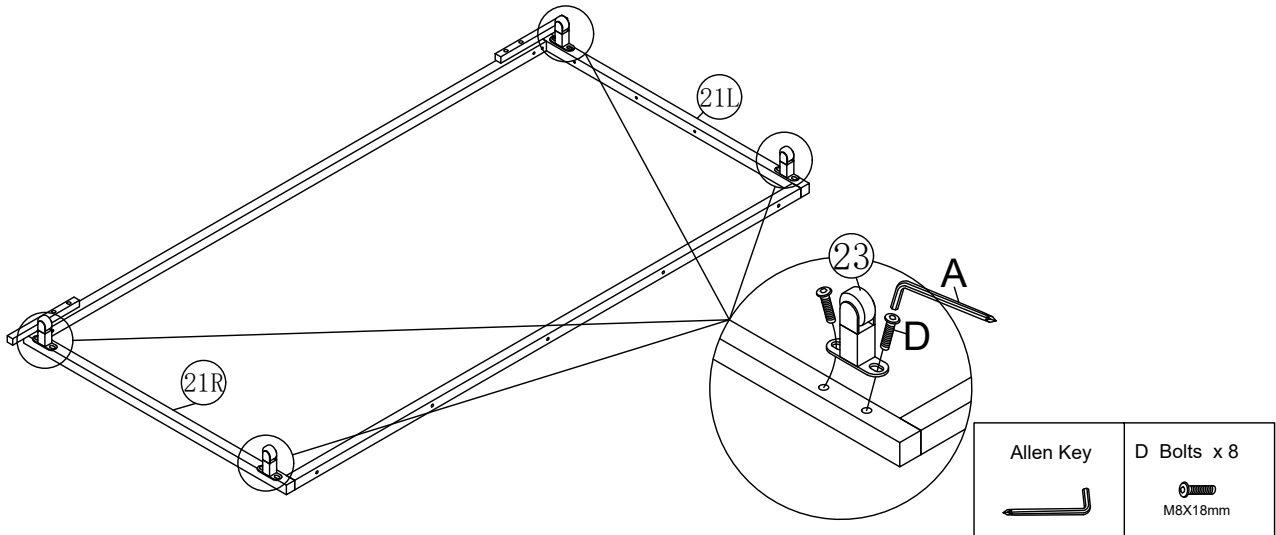

Step 12

Fix the Lifting system ①⑦ to the Bottom bed base cross bar ②① with Bolts E by using Allen key A.
(Befestigen Sie das Hebesystem ①⑦ mit Schrauben E mit Inbusschlüssel A am Unterbettquerstab ②①.)

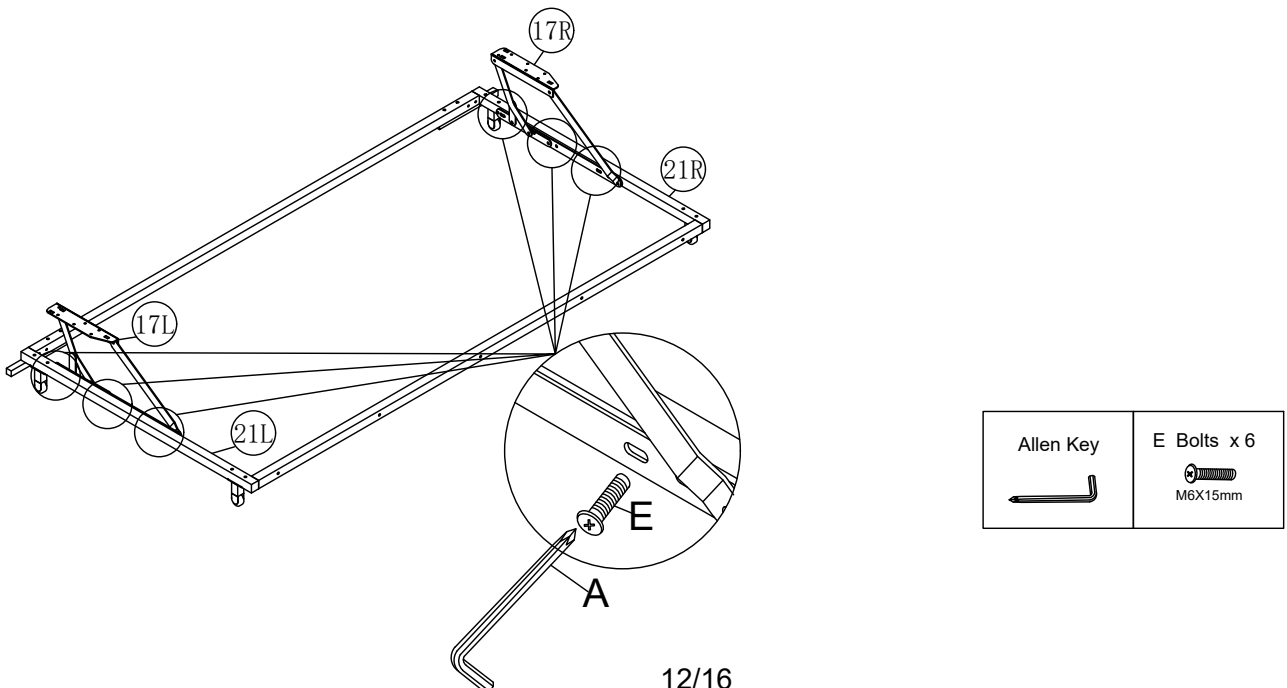

Step 13

Fix the Bottom bed side panels ⑤ to the Bottom bed base board ④ with Four hole iron G and Bolts D by using Allen key A.
 (Befestigen Sie die Seitenwände am unteren Bett ⑤ mit Vier-Loch-Eisen G und Bolzen D mithilfe eines Inbusschlüssels A an der Untere Bett-Fußleiste ④.)

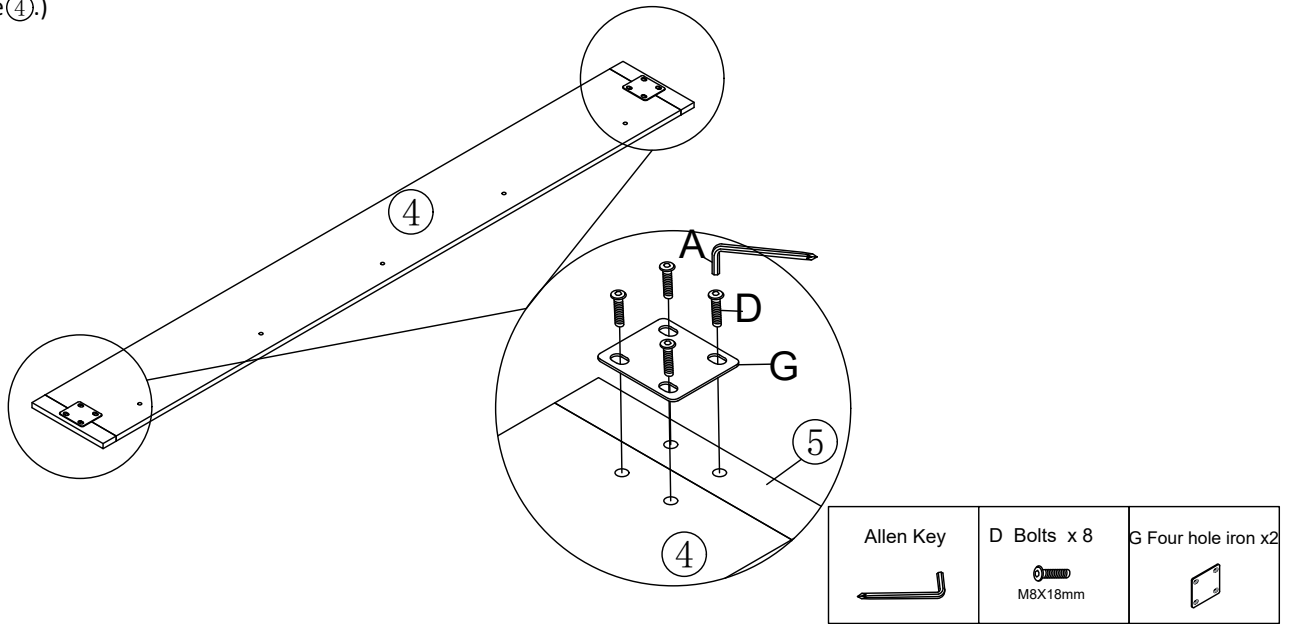

Step 14

Fix the Bottom bed base board ④ and the Bottom bed base side bar ②⑩ together with Bolts B by using Allen key A.
 (Befestigen Sie die Bodenplatte ④ und die Seitenleiste ②⑩ des Bodenbetts zusammen mit Schrauben B mit Inbusschlüssel A.)

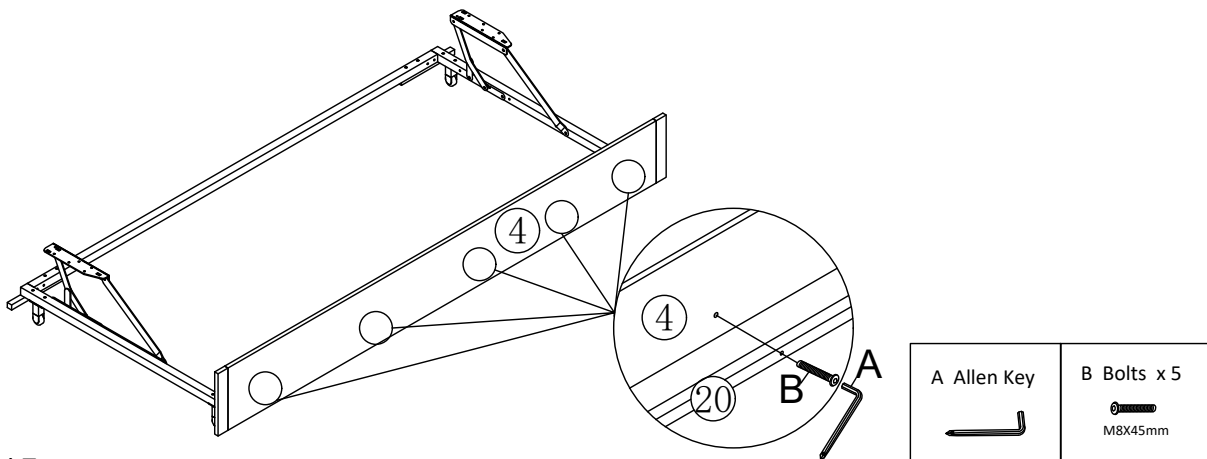

Step 15

Fix the Bottom bed top side bar ⑬, ⑭ and Bottom bed top cross bar ⑮ together with Bolts E by using Allen key A.
 (Befestigen Sie die unteren Seitenstreben ⑬, ⑭ und die unteren Querstreben ⑮ der oberen Bettobenseite mit den Schrauben E unter Verwendung eines Inbusschlüssels A.)

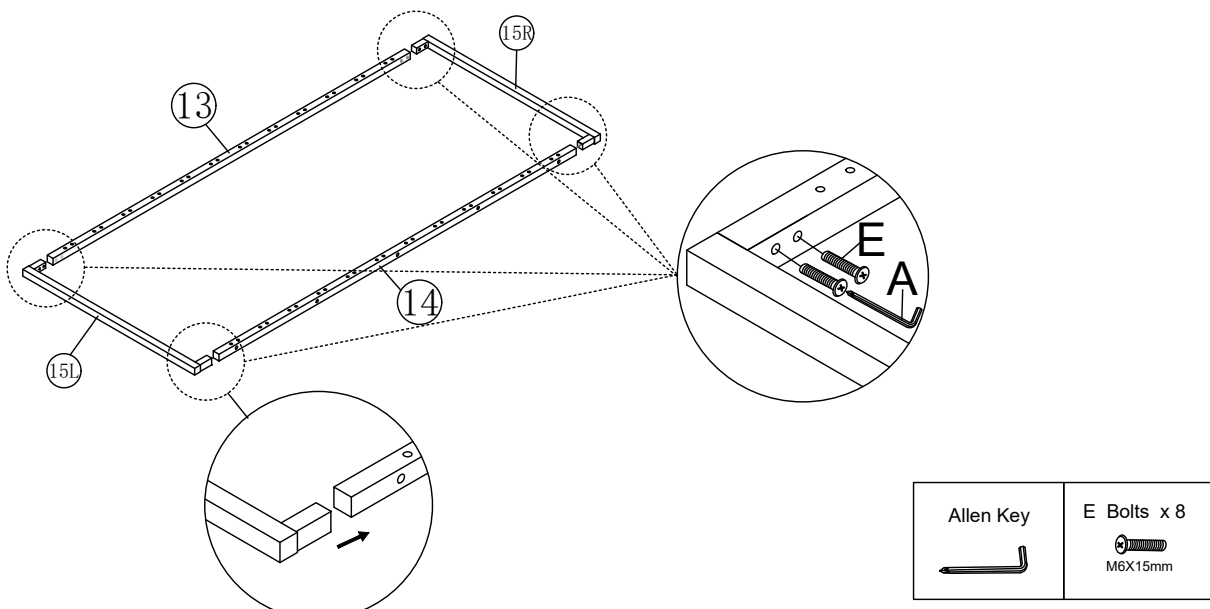

Step 16

Fix the Salts ⑯ to the Bottom bed top side bar ⑬ and ⑭ with End slats cap J .

(Befestigen Sie die Salze ⑯ mit der Endlattenkappe J an den oberen Seitenstangen ⑬ und ⑭ des unteren Bettes.)

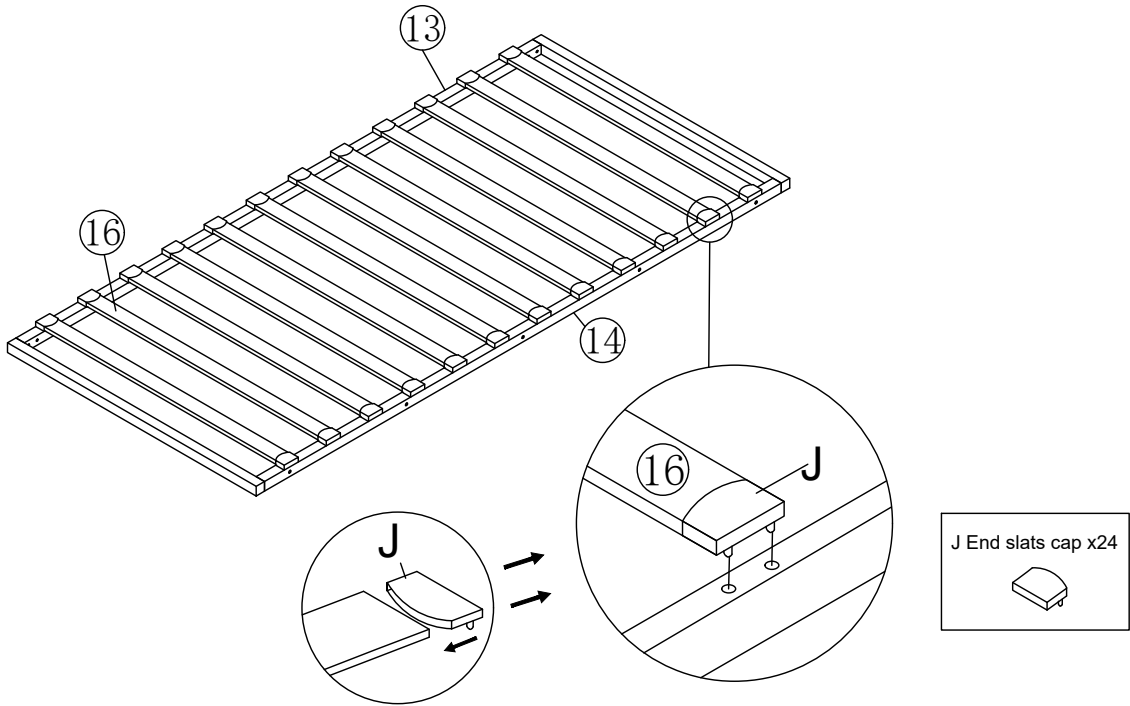

Step 17

Fix the Bottom bed top board ⑱ to the Bottom bed top side bar ⑭ with Bolts B by using Allen key A.

(Befestigen Sie die untere Bettoberplatte ⑱ mit den Schrauben B und einem Inbusschlüssel A an der unteren Bettenseitenstange ⑭.)

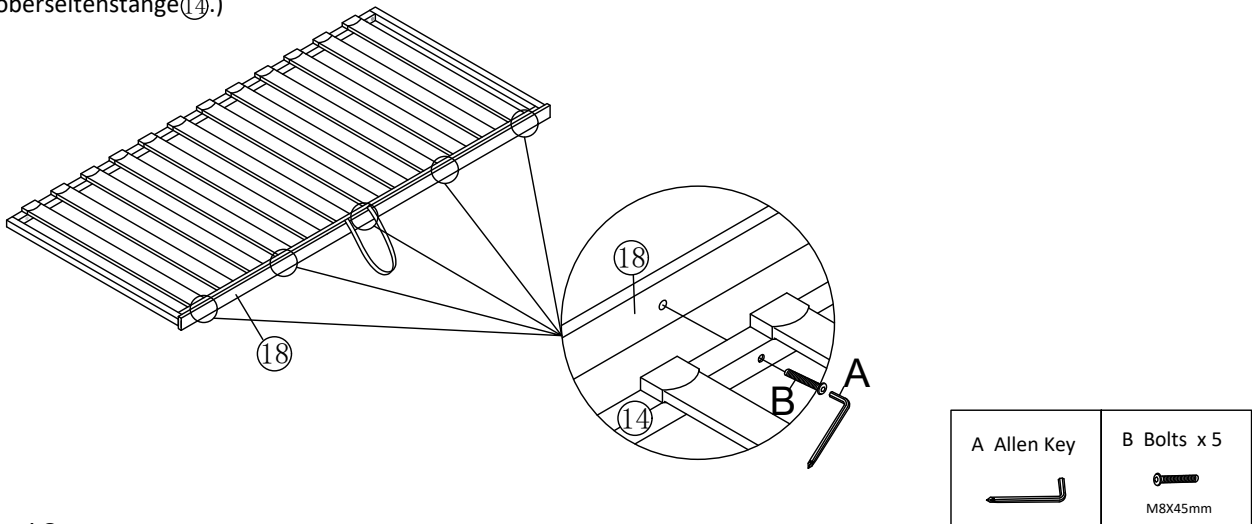

Step 18

Fix the top parts of the Lifting system ⑰ to the Bottom bed top cross bar ⑮ with Bolts E by using Allen key A.

(Befestigen Sie die oberen Teile des Hebesystems ⑰ mit den Schrauben E und einem Inbusschlüssel A an der oberen Querstrebe ⑮ des unteren Betts.)

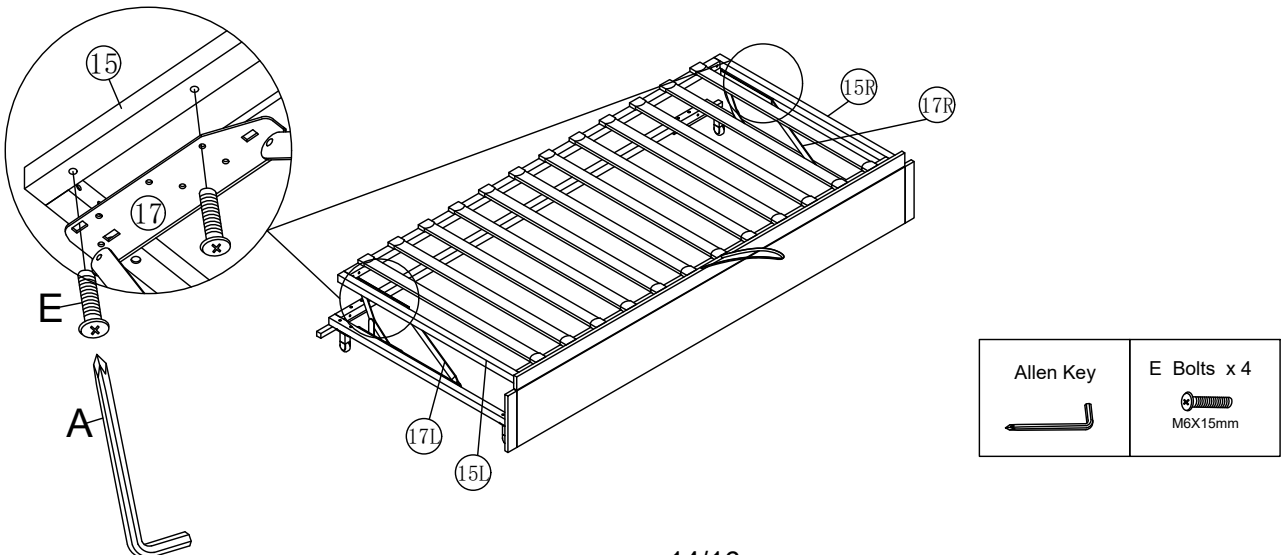

Step 19

Put the Bottom bed into the bed. then tighten all hardware. The Transverse square tube ① should be stopped by the Vertical square tubes ②.

(Setzen Sie das untere Bett in das Bett, Ziehen Sie alle Beschläge fest, die Vierkantrohr ① sollte von der Vierkantrohr ② gestoppt werden.)

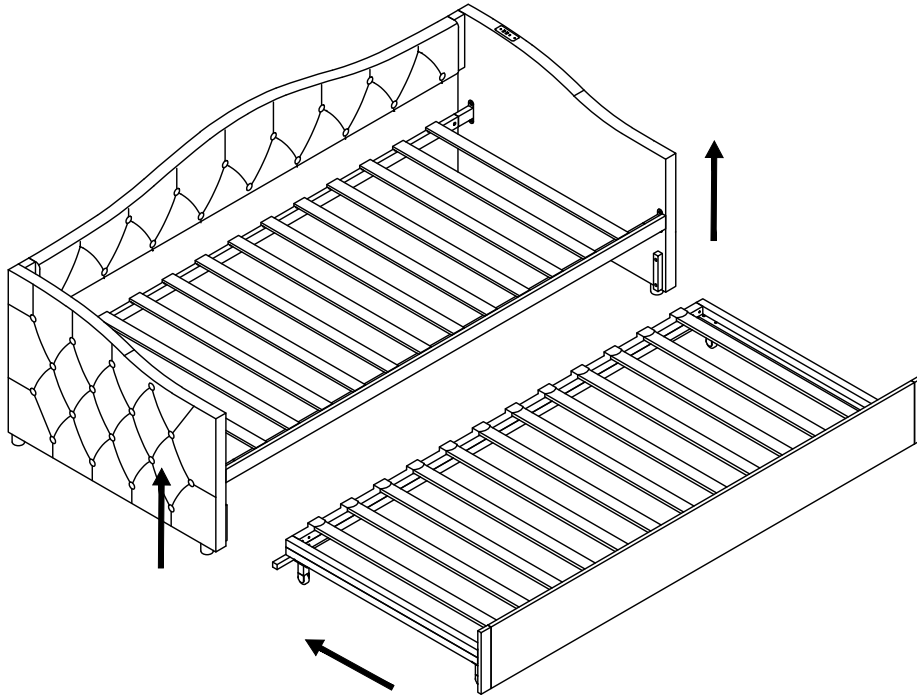

Step 20

Contact the power to use the USB.

(Wenden Sie sich an das Netzteil, um den USB-Anschluss zu verwenden.)

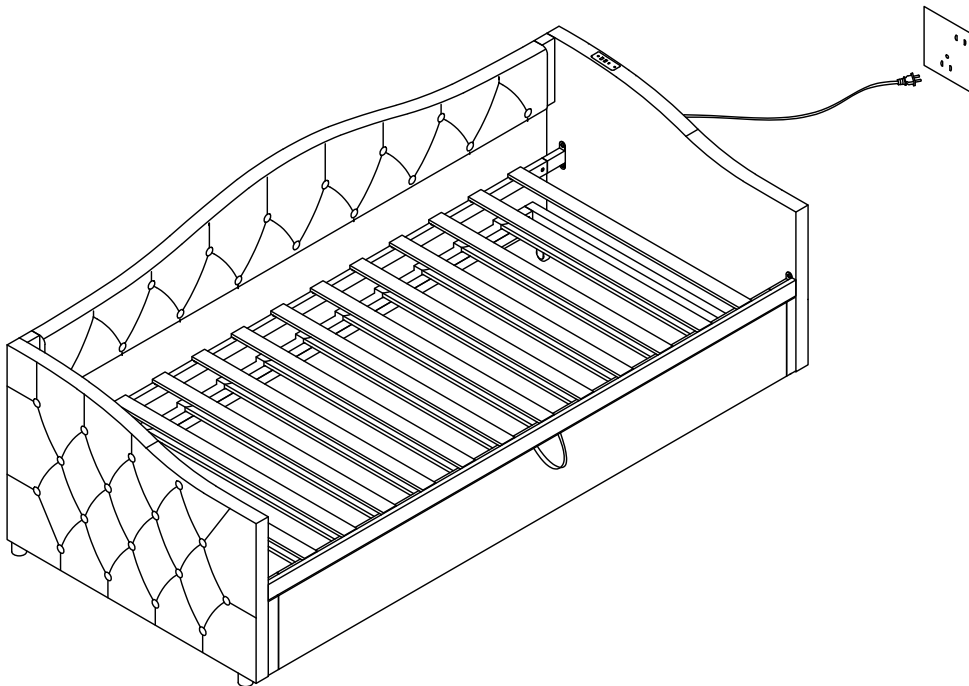

Step 21

Please notice that it can be used in three ways as follows, and everything is finished now please enjoy your bed.
(Bitte beachten Sie, dass es auf drei Arten wie folgt verwendet werden kann, und alles ist jetzt fertig, genießen Sie bitte Ihr Bett.)

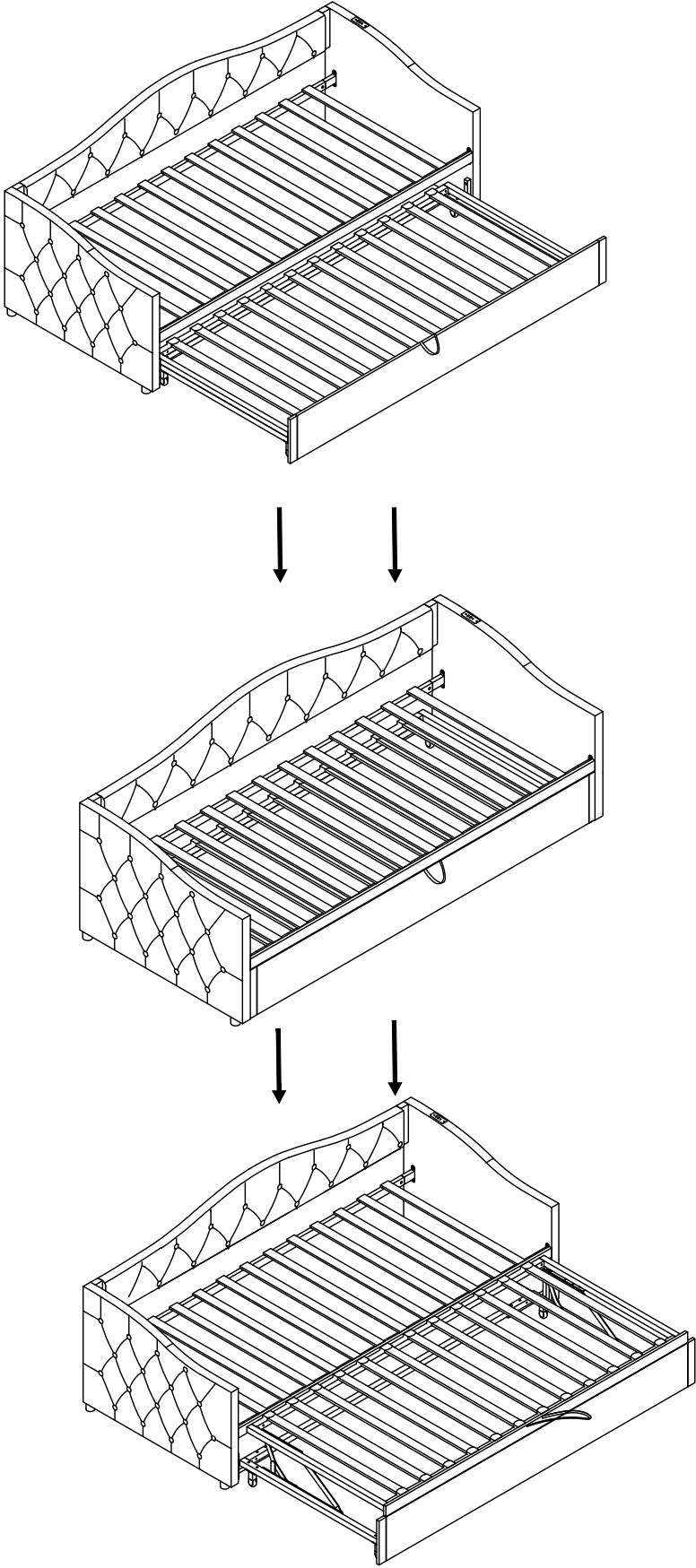

Reference No. : WTN24N04082949E
Applicant : GuangdongZhangongElectricalTechnologyCo.,LTD
Address : 701,Building29,ZhifuGarden,XingtanTown,ShundeDistrict,FoshanCity
Manufacturer : Same as applicant
Address : Same as applicant
Product : Furniture socket
Model No. : ZG-JJ/10A/16A, details see attachment
Technical data : 250 Vac, 50 - 60 Hz, other details see attachment



Test Standards:

EN 55032:2015+A11:2020
EN 55035:2017+A11:2020
EN IEC 61000-3-2:2019+A1:2021
EN 61000-3-3:2013+A1:2019+A2:2021

The above product has been tested by us with the listed standards and found in compliance with the European Electromagnetic Compatibility Directive 2014/30/EU. It is possible to use CE marking to demonstrate the compliance with this EMC Directive.

EN 55032: Electromagnetic compatibility of multimedia equipment - Emission Requirements
EN 55035: Electromagnetic compatibility of multimedia equipment - Immunity requirements
EN IEC 61000-3-2: Electromagnetic compatibility (EMC) - Part 3-2: Limits - Limits for harmonic current emissions (equipment input current \leq 16 A per phase)
EN 61000-3-3: Electromagnetic compatibility (EMC) -Part 3-3: Limits -Limitation of voltage changes, voltage fluctuations and flicker in public low-voltage supply systems, for equipment with rated current \leq 16 A per phase and not subject to conditional connection

The referred test report(s) show that the product complies with standard(s) recognized as giving presumption of compliance with the essential requirements in the above mentioned EU Directive. Other relevant Directives have to be observed.

After preparation of the necessary technical documentation as well as the EU Declaration of Conformity, the CE marking as shown below can be affixed on the equipment under the sole responsibility of the manufacturer.



Manager: Jianzhong Mao
Date: 2024-05-06

The statement is based on a single evaluation of the sample of above mentioned product. It does not imply an assessment of the whole production.

Waltek Testing Group (Ningbo) Co., Ltd.

Hotline: 400-840-2288 E-mail: nb@waltek.com.cn
Http://www.waltek.com.cn



Attachment

Model list



Reference No: WTN24N04082949E

No.	Model	Rated Input	Max Output	Note
1.	G-PDUM0/12A/15A	250 Vac, 50 - 60 Hz, 16 A	2 * Type-A Output: Max. 5 Vdc, 2 A, AC Output: Max.16 A	With multiple socket-outlets, with USB output
2.	ZG-PDUG1/10A/16A			
3.	ZG-PDUG2/10A/16A			
4.	ZG-PDUG3/10A/16A			
5.	ZG-PDUG4/10A/16A			
6.	ZG-PDUF/10A/16A			
7.	ZG-PDUW1/10A/16A			
8.	ZG-PDUW2/10A/16A			
9.	ZG-PDUB/10A/16A			
10.	ZG-PDUC3/10A/15A			
11.	ZG-PDUC9/10A/15A			
12.	ZG-PDUA/10A/15A			
13.	ZG-PDUY/10A/15A			
14.	ZG-JJ/12A/15A			
15.	ZG-HG/12A/15A			
16.	ZG-ZJ/12A/15A			
17.	ZG-SJ/12A/15A			
18.	ZG-DQ/12A/15A			
19.	ZG-PC/12A/15A			
20.	ZG-PDU00/10A/16A			
21.	ZG-JJ/10A/16A			

