

- D** Gebrauchsanweisung
- NL** Gebruiksrichtlijnen
- IT** Istruzioni per l'uso
- CZ** Pokyny k použití
- HU** Használati útmutató
- PT** Instruções de utilização
- SK** Pokyny k použitiu

- GB** Instructions for use
- FR** Instructions d'utilisation
- PL** Instrukcja obsługi
- ES** Instrucciones de empleo
- RO** Instrucțiuni de folosire
- RU** Инструкция по монтажу
- TR** Kullanım talimatları

Please check that you have all the parts listed before you start assembling, if you do find that something is missing, do not continue assembly, please contact us immediately.

NOTE: Please do not completely tighten all the hardware until the entire assembly is complete!

Bitte überprüfen Sie, ob alle Teile mitgeliefert sind, bevor Sie mit der Montage beginnen. Wenn Sie festlegen, dass etwas fehlt, setzen Sie die Montage nicht fort. Bitte kontaktieren Sie uns sofort.

Achtung : Bitte ziehen Sie nicht alle Schrauben fest, bevor die Montage abgeschlossen ist !

This set will be shipped by 2 boxes and they may arrive on different days. If both packages arrived but parts missing, please contact customer service.

Dieses Set ist in 2 Boxen enthalten. Wenn Sie keine vollen 2 Boxen erhalten, wenden Sie sich bitte an unseren Kundenservice

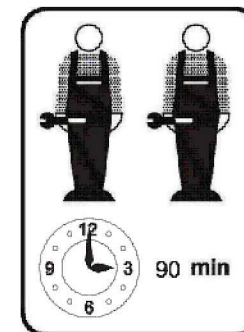

SKU: N623P328950/N623P328951



English

IMPORTANT FOR GAS LIFT BEDS&MAINTAINCE

- Please place the mattress on top of the bed frame.
- Please do not pull on the strap handles.
- Please press heavily to release the compressed gas.
- Periodically check all screw & fixings to ensure they are secure.
- When moving your product, carefully lift into place.
- Wipe clean with a slightly damp cloth- please do not use abrasive chemicals or bleach.
- Do NOT allow children to operate the lift mechanism.
- Do NOT allow children near the lift base when operating the mechanism.
- Do NOT stand inside the bed or the internal storage base.
- Do NOT overload the internal storage base.
- DO NOT jump on the product or any of its parts.

WICHTIG FÜR GASLIFT-BETTEN&WARTUNG

- Bitte legen Sie die Matratze oben auf den Bettrahmen.
- Bitte ziehen Sie nicht an den Gurtgriffen.
- Bitte drücken Sie kräftig, um das komprimierte Gas freizusetzen.
- Überprüfen Sie regelmäßig alle Schrauben und Befestigungen, um sicherzustellen, dass sie sicher sind.
- Wenn Sie Ihr Produkt bewegen, heben Sie es vorsichtig an seinen Platz.
- Mit einem leicht feuchten Tuch abwischen - bitte keine scheuernden Chemikalien oder Bleichmittel verwenden.
- Erlauben Sie Kindern NICHT, den Hebemechanismus zu bedienen.
- Lassen Sie Kinder NICHT in die Nähe des Liftsockels, wenn Sie den Mechanismus bedienen.
- Stellen Sie sich NICHT in das Bett oder in die Innenablage.
- Überlasten Sie den internen Liftsockel NICHT.
- Springen Sie NICHT auf das Produkt oder eines seiner Teile.

IMPORTANT POUR LES LITS À RELEVAGE DE GAZ&MAINTENANCE

- Veuillez placer le matelas sur le dessus du cadre de lit.
- Ne tirez pas sur les poignées de la sangle.
- Appuyez fortement pour libérer le gaz comprimé.
- Vérifiez régulièrement que toutes les vis et fixations sont bien en place.
- Lorsque vous déplacez votre produit, soulevez-le avec précaution pour le mettre en place.
- Nettoyez avec un chiffon légèrement humide - n'utilisez pas de produits chimiques abrasifs ou d'eau de Javel.
- Ne laissez pas les enfants utiliser le mécanisme de levage.
- Ne laissez pas les enfants s'approcher de la base de levage lorsqu'ils actionnent le mécanisme.
- Ne vous tenez PAS à l'intérieur du lit ou de la base de stockage interne.
- Ne surchargez pas la base de stockage interne.
- Ne pas sauter sur le produit ou l'une de ses parties.

IMPORTANTE PER I LETTI CON SOLLEVAMENTO A GAS E LA MANUTENZIONE

- Posizionare il materasso sopra la struttura del letto.
- Non tirare le maniglie della cinghia.
- Premere con forza per rilasciare il gas compresso.
- Controllare periodicamente tutte le viti e i fissaggi per assicurarsi che siano saldi.
- Quando si sposta il prodotto, sollevarlo con cautela.
- Pulire con un panno leggermente umido, senza usare prodotti chimici abrasivi o candeggina.
- NON permettere ai bambini di azionare il meccanismo di sollevamento.
- NON permettere ai bambini di avvicinarsi alla base di sollevamento quando si aziona il meccanismo.
- NON sostare all'interno del letto o della base di contenimento interna.
- NON sovraccaricare la base di contenimento interna.
- NON saltare sul prodotto o sulle sue parti.

IMPORTANTE PARA LAS CAMAS ELEVADORAS DE GAS&MANTENIMIENTO

- Coloque el colchón sobre el somier.
- No tire de las asas de la correa.
- Presione con fuerza para liberar el gas comprimido.
- Compruebe periódicamente que todos los tornillos y fijaciones estén bien sujetos.
- Al mover el producto, levántelo con cuidado para colocarlo en su sitio.
- Limpie con un paño ligeramente humedecido; no utilice productos químicos abrasivos ni lejía.
- NO permita que los niños accionen el mecanismo de elevación.
- NO permita que los niños se acerquen a la base elevadora cuando accionen el mecanismo.
- NO se ponga de pie dentro de la cama o de la base de almacenamiento interna.
- NO sobrecargue el somier.
- NO salte sobre el producto ni sobre ninguna de sus piezas.



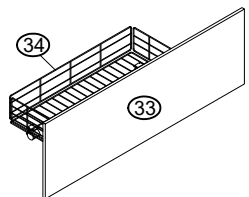
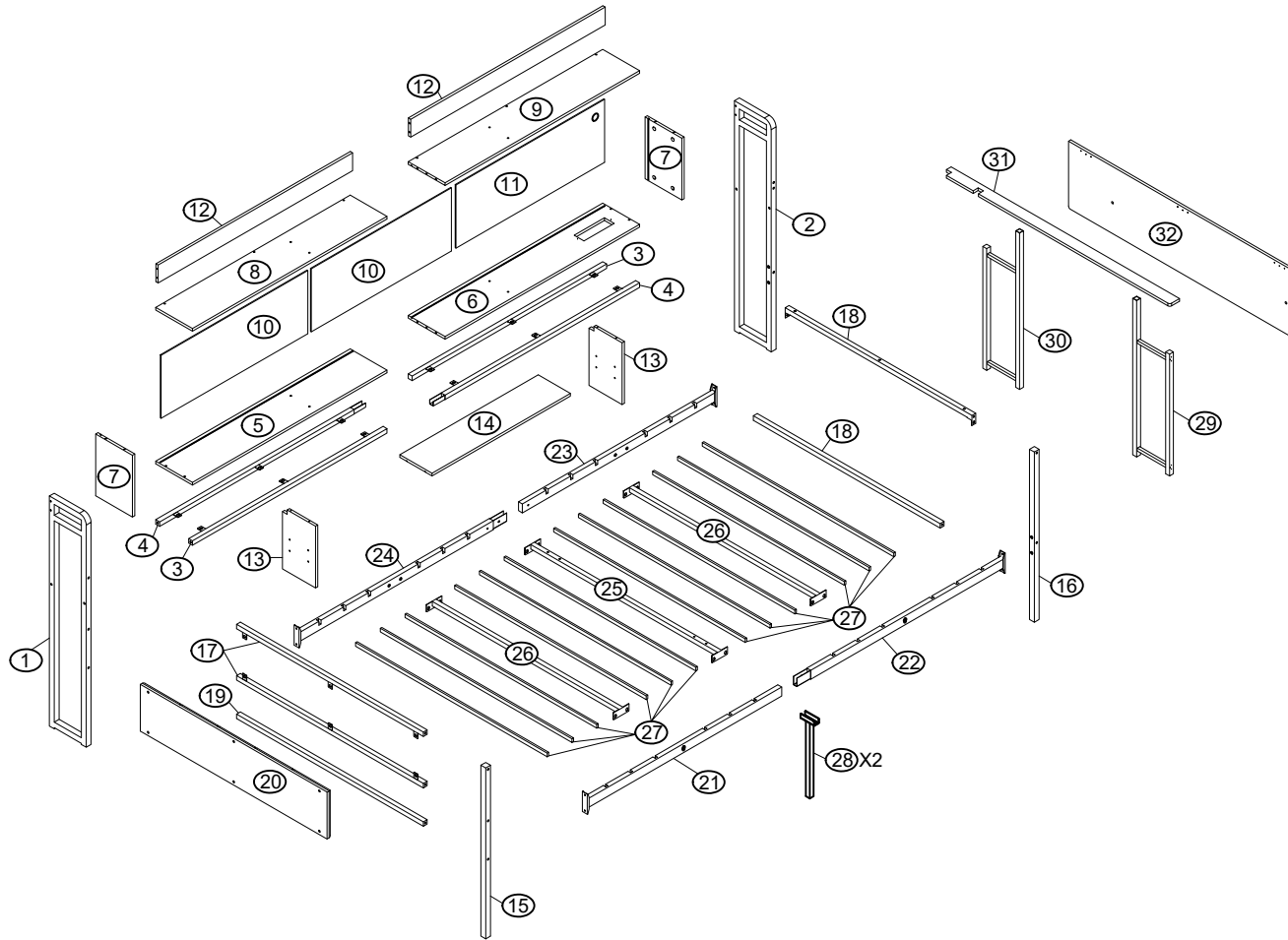







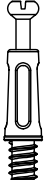

Montageanleitung für Bettgestell

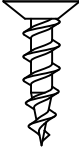
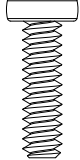
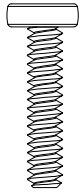
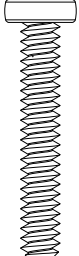
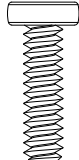

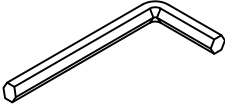
x 2

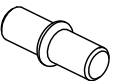
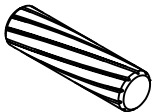
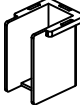
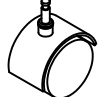
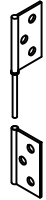

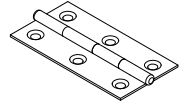
Montageanleitung für Bettgestell

Hardware parts Hardware-Teile SKU N623P328951

<p>(A) x12</p>  <p>CAMLOCK</p>	<p>(B) x12</p>  <p>SCREW</p>	<p>(C) x18</p>  <p>Ø5 x 38mm</p>	<p>(D) x20</p>  <p>Ø4 x 10mm</p>	<p>(E) x26</p>  <p>Ø1/4" x 11mm</p>	<p>(F) x24</p>  <p>Ø4 x 20mm</p>	<p>(G) x16</p>  <p>Ø1/4" x 14mm</p>
<p>(H) x7</p>  <p>Ø1/4" x 28mm</p>	<p>(I) x14</p>  <p>Ø1/4" x 50mm</p>	<p>(J) x12</p>  <p>M8 x 16mm</p>	<p>(K) x1</p>  <p>M3</p>	<p>(L) x1</p>  <p>M4</p>	<p>(M) x1</p>  <p>M5</p>	<p>(N) x1</p>  <p>SOCKET</p>
<p>(O) x4</p>  <p>SHELF SUPPORT</p>	<p>(P) x4</p>  <p>CAM BOLT</p>	<p>(Q) x24</p>  <p>PLASTIC CAP</p>	<p>(R) x2</p> 	<p>(S) x4</p>  <p>S1 x4</p>  <p>S2 x4</p>	<p>(T) x3</p> 	<p>(U) x4</p>  <p>Ø1/4" x 16mm</p>

Montageanleitung für Bettgestell

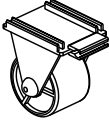
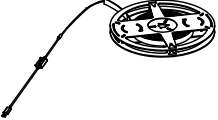
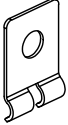
Hardware parts Hardware-Teile SKU N623P328951

Ⓜ x8 	ⓧ x1 	Ⓨ x2 	Ⓩ x4 	ⒶⒶ x1 		





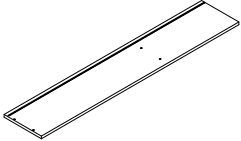
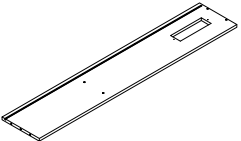
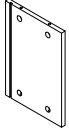
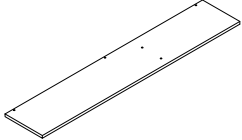
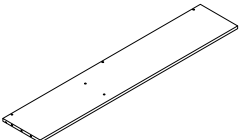
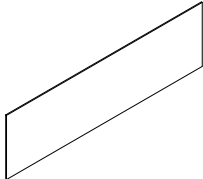
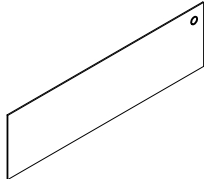
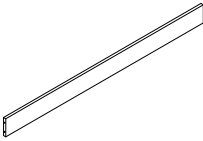
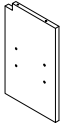
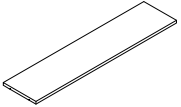
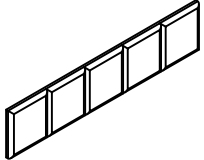
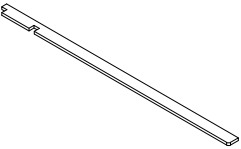
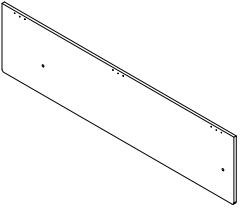
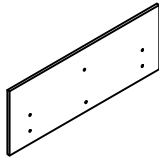
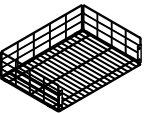

Montageanleitung für Bettgestell

Hardware parts Hardware-Teile SKU N623P328950

<p>⑤ x1</p> 	<p>⑥ x1</p> 	<p>⑦ x2</p> 	<p>⑧ x1</p> 	<p>⑨ x1</p> 	<p>⑩ x2</p> 	<p>⑪ x1</p> 
<p>⑫ x2</p> 	<p>⑬ x2</p> 	<p>⑭ x1</p> 	<p>⑳ x1</p> 	<p>㉑ x1</p> 	<p>㉒ x1</p> 	<p>㉓ x2</p> 
<p>㉔ x2</p> 						

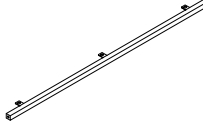
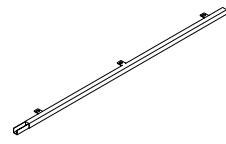
Montageanleitung für Bettgestell

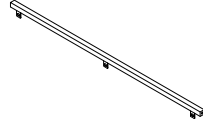
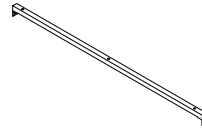
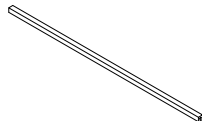
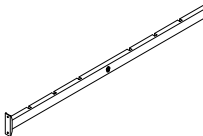
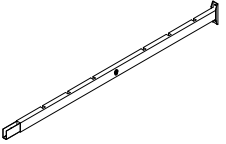
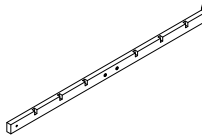
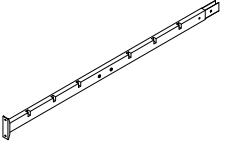
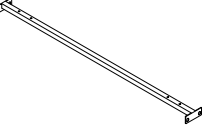
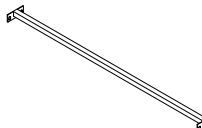
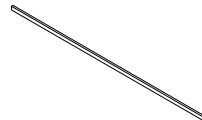
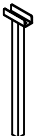
Hardware parts Hardware-Teile SKU N623P328951

① x1 	② x1 	③ x2 	④ x2 	⑤ x1 	⑥ x1 	⑦ x2 
⑧ x1 	⑨ x2 	⑩ x1 	⑪ x1 	⑫ x1 	⑬ x1 	⑭ x1 
⑮ x2 	⑯ x12 	⑰ x2 	⑱ x1 	⑲ x1 		

Montageanleitung für Bettgestell

STEP 1

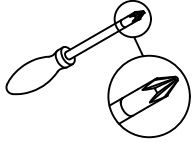

(B) 8PCS

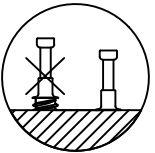
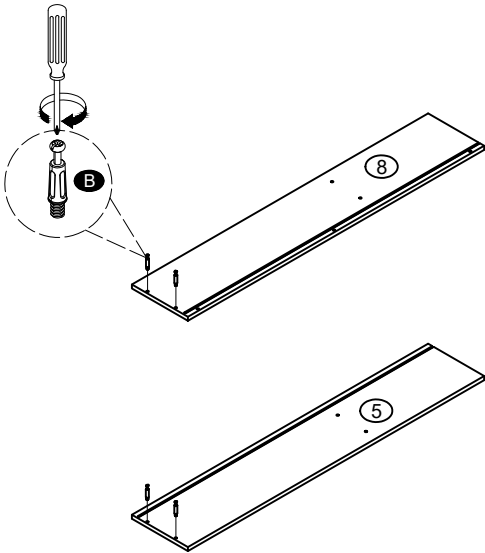

STEP 2

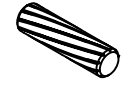
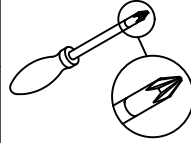

(P) 2PCS



(A) 4PCS



(B) 4PCS

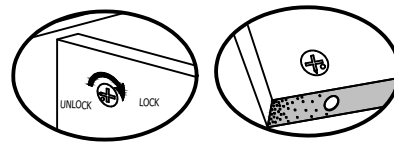
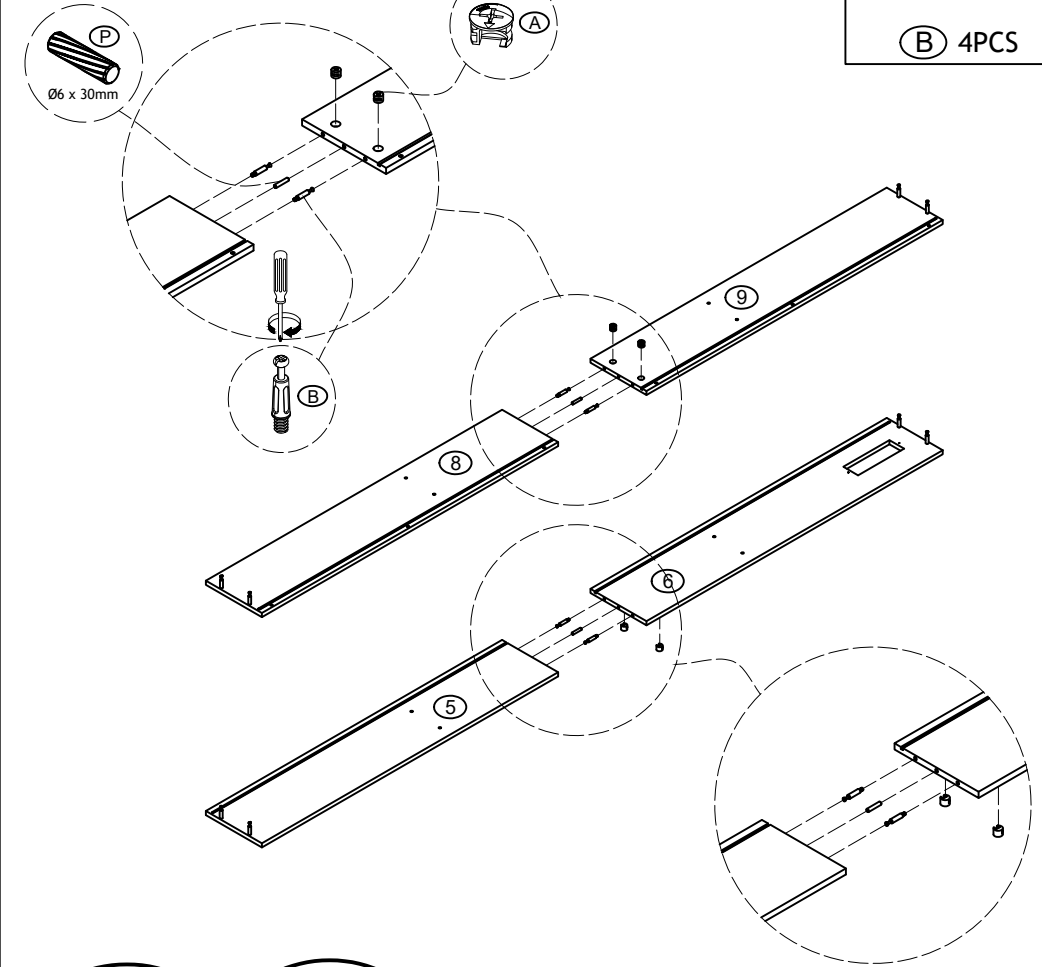

Proper orientation of CAM LOCK

Montageanleitung für Bettgestell

STEP 3



M3

(K) 1PCS



(A) 4PCS



Ø5 x 38mm

(C) 4PCS

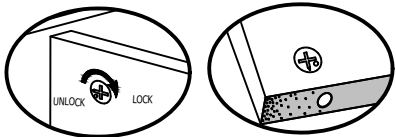
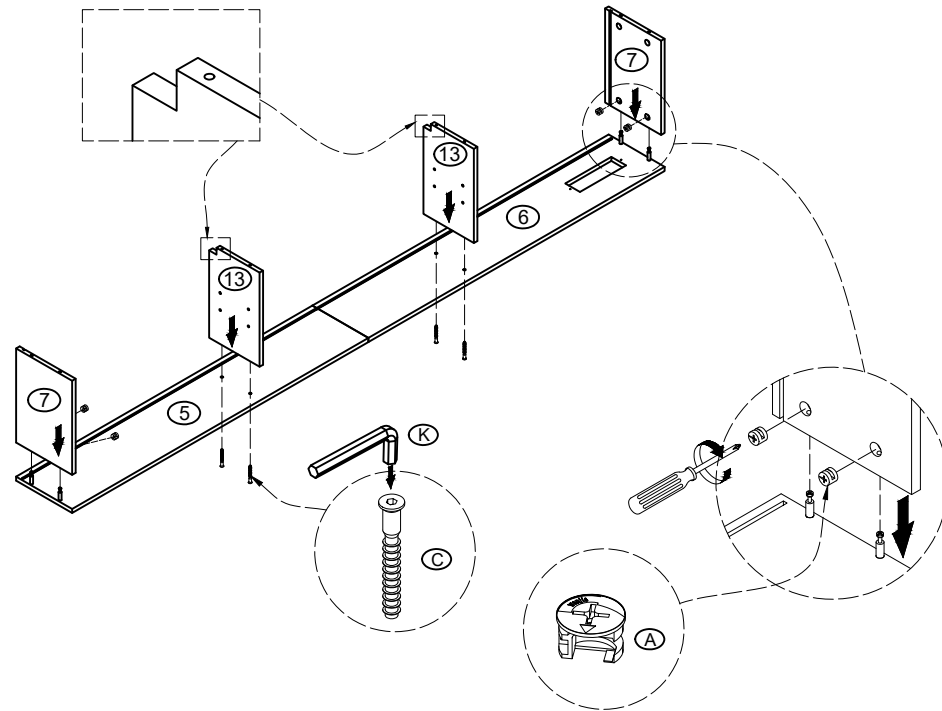

Proper orientation of CAM LOCK

STEP 4

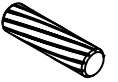

(P) 2PCS

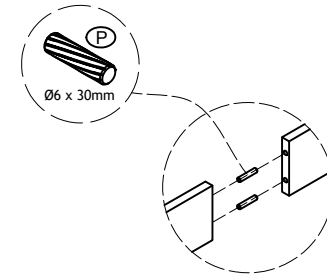

Ø6 x 30mm

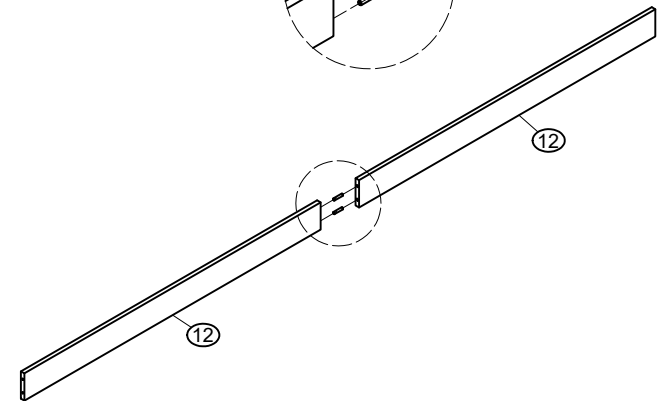

Montageanleitung für Bettgestell

STEP 5



M3

(K) 1PCS



Ø5 x 38mm

(C) 6PCS

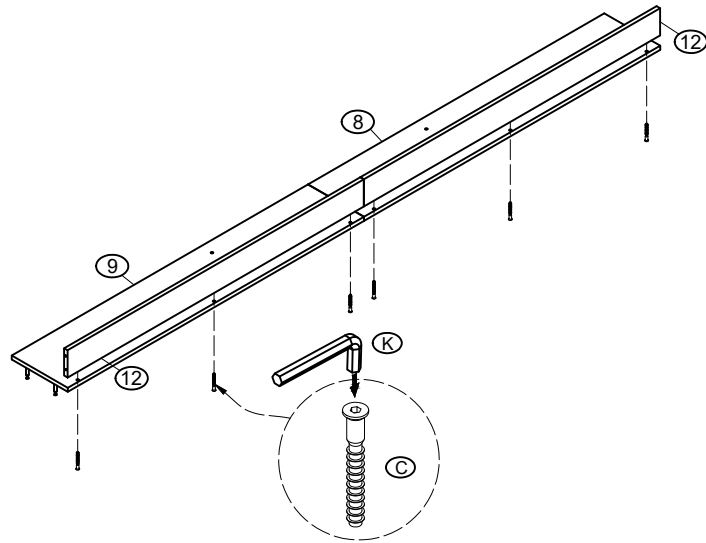

STEP 6

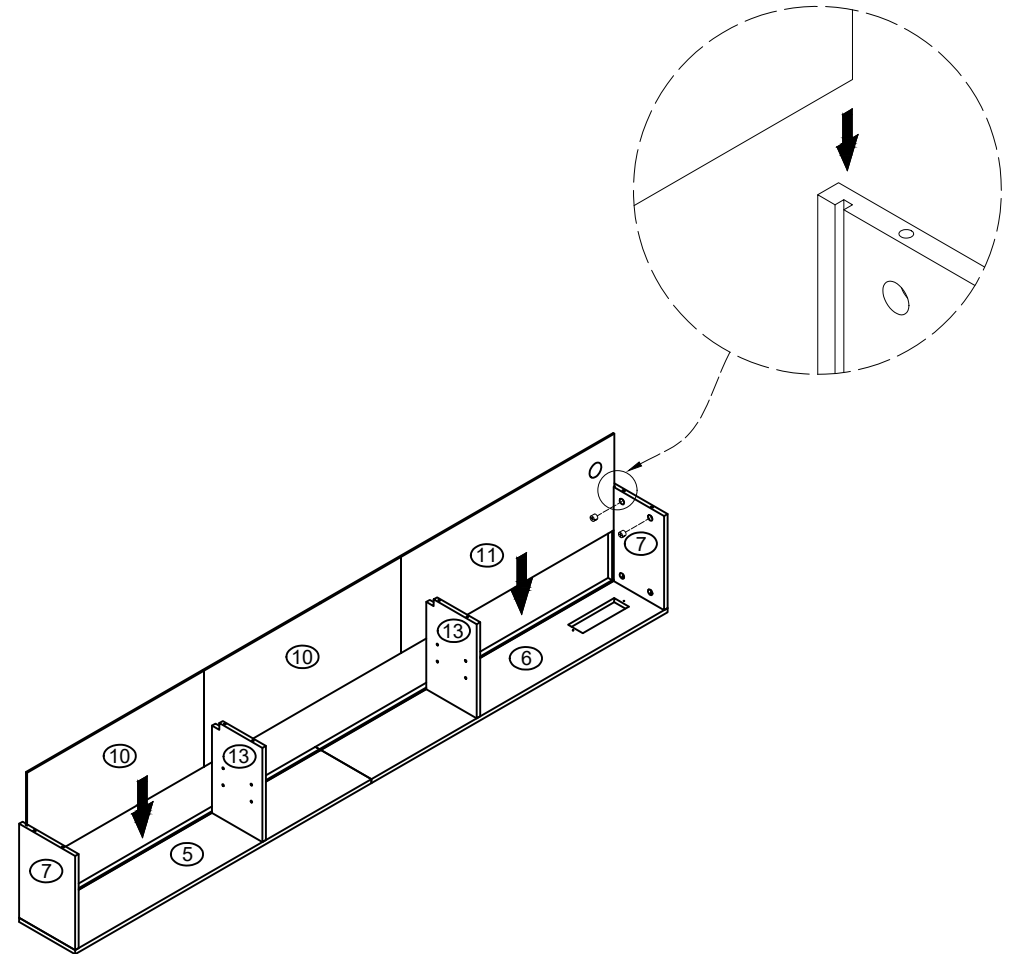

Montageanleitung für Bettgestell

STEP 7

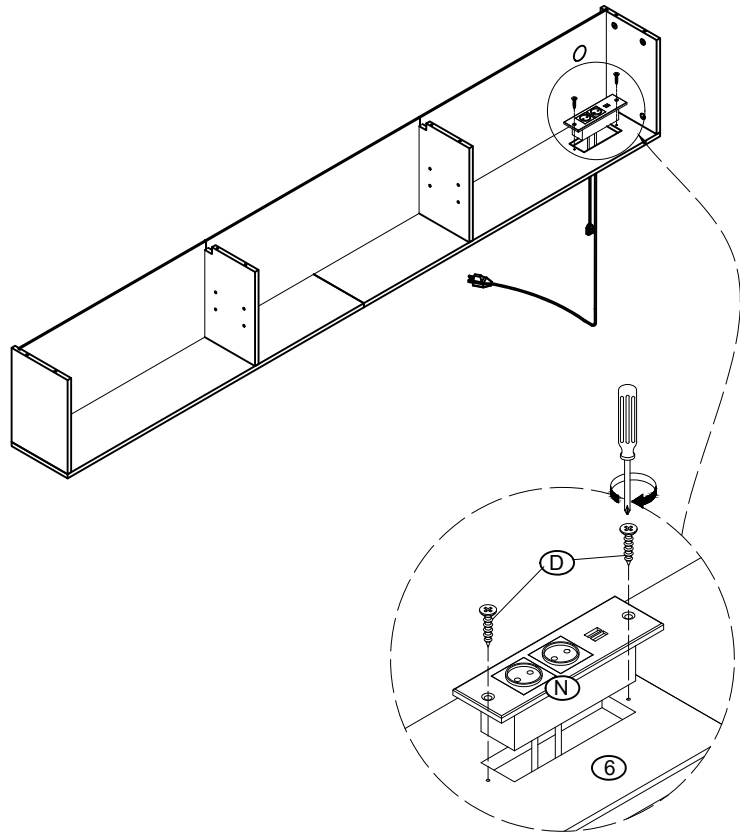
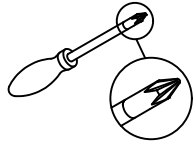

(N) 1PC



Ø4 x 10mm

(D) 2PCS

STEP 8



M3

(K) 1PCS



(A) 4PCS

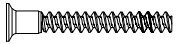

Ø5 x 38mm

(C) 4PCS

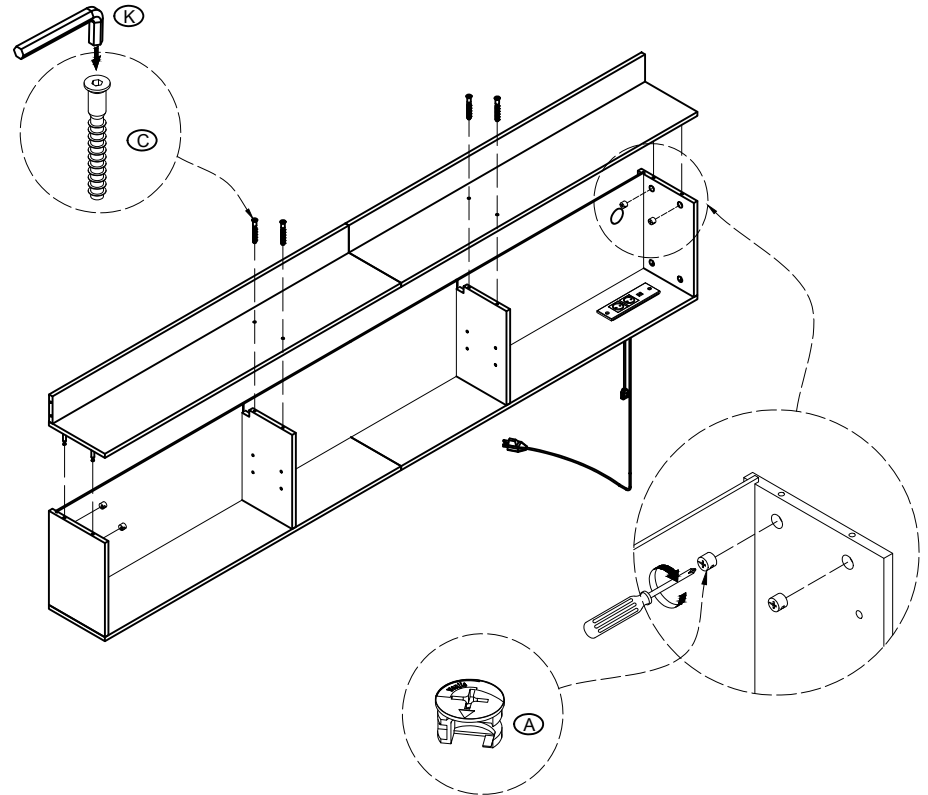

Montageanleitung für Bettgestell

STEP 9



Ø1/4" x 11mm

(E) 4PCS

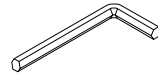

M4

(L) 1PC

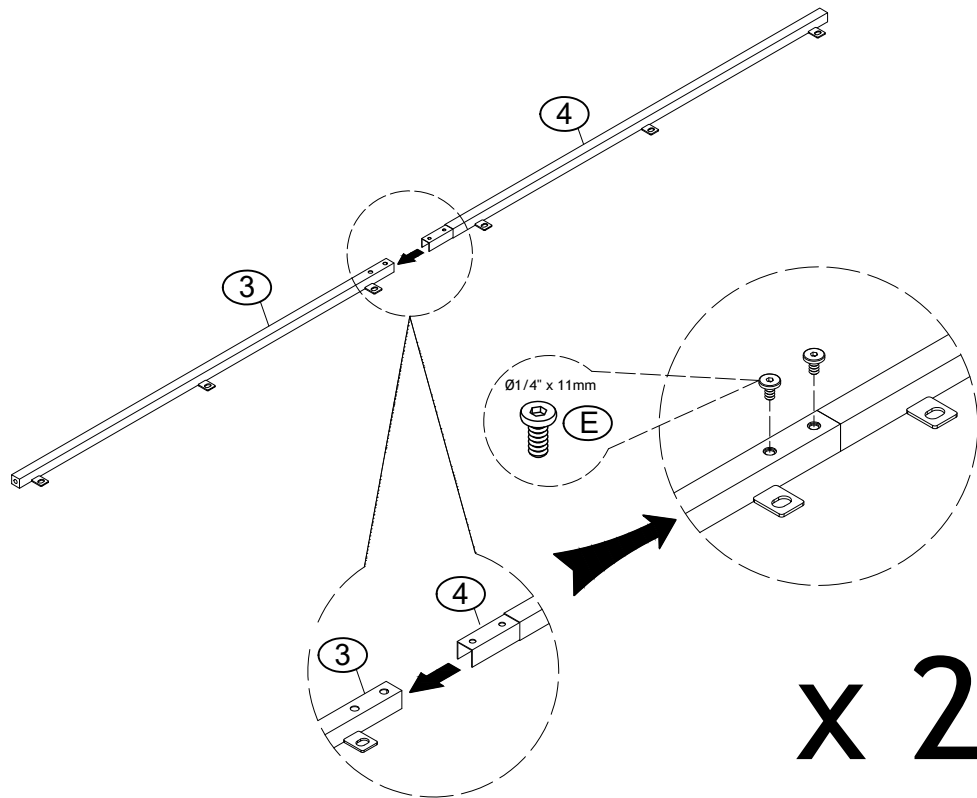

STEP 10



Ø1/4" x 50mm

(I) 4PCS

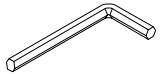

M4

(L) 1PC

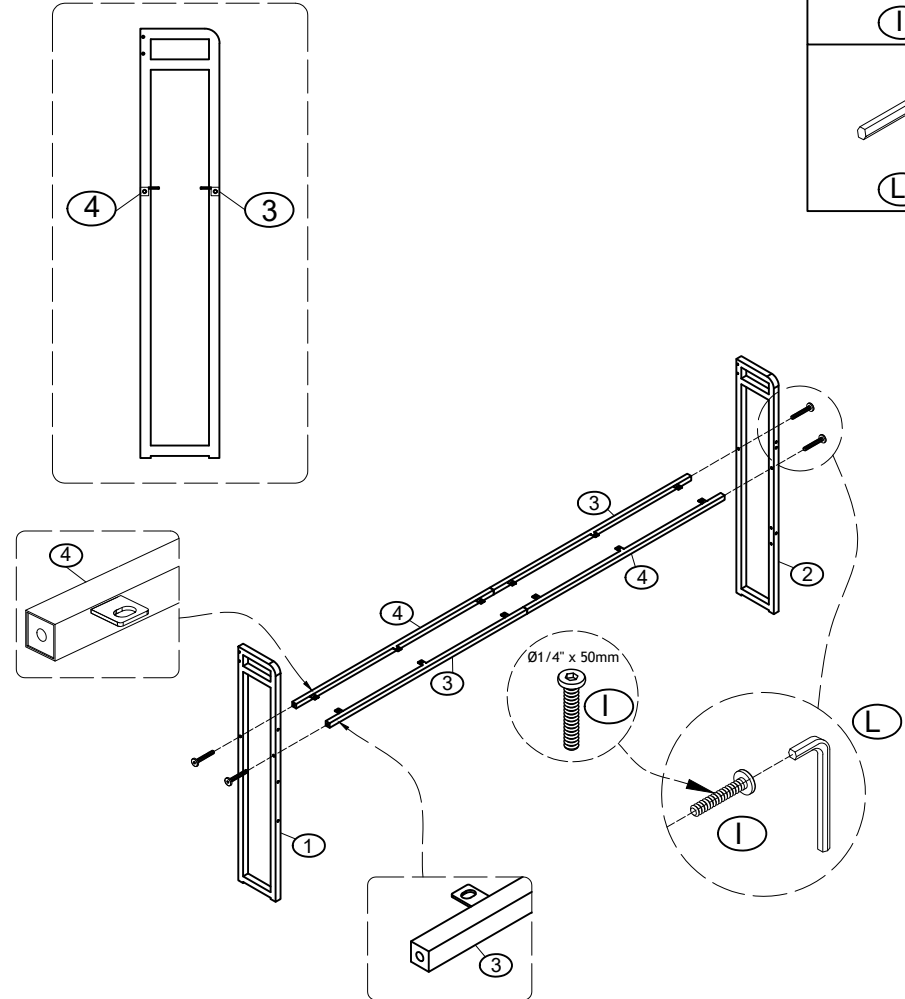

Montageanleitung für Bettgestell

STEP 11



Ø1/4" x 11mm

(E) 12PCS

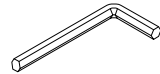

M4

(L) 1PC

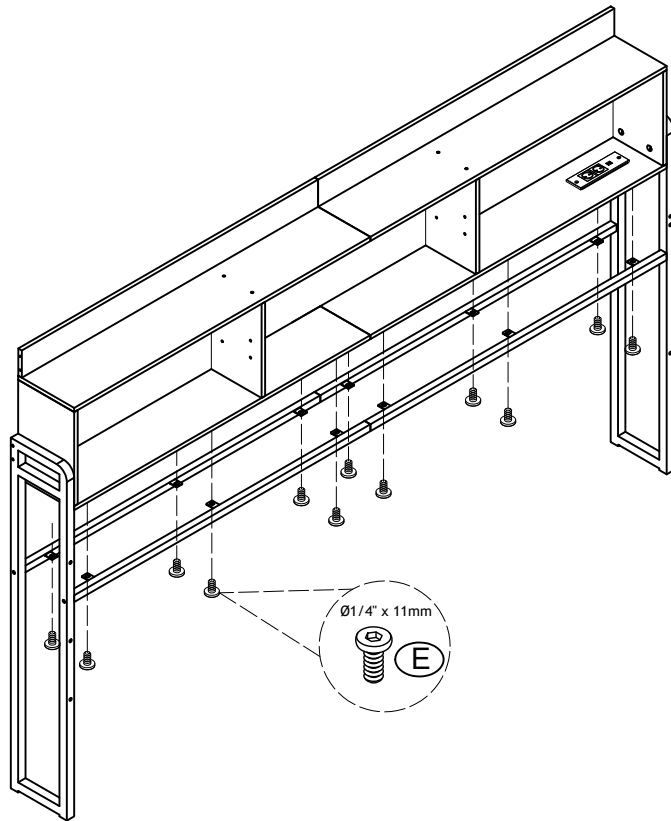

STEP 12

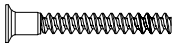

Ø5 x 38mm

(C) 4PCS



M3

(K) 1PCS

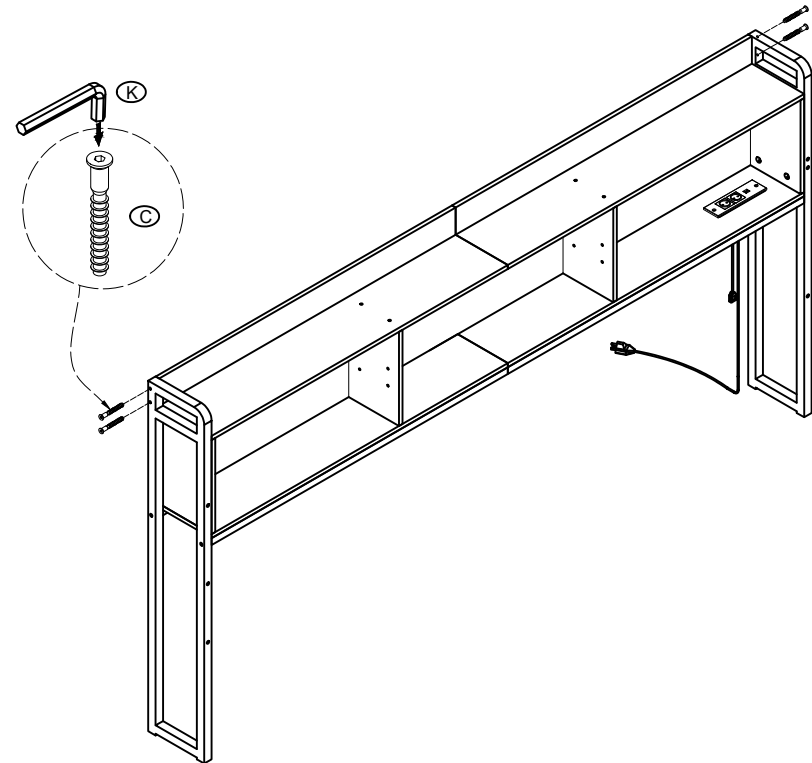

Montageanleitung für Bettgestell

STEP 13

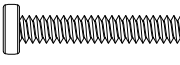

Ø1/4" x 14mm
ⓐ 1PCS

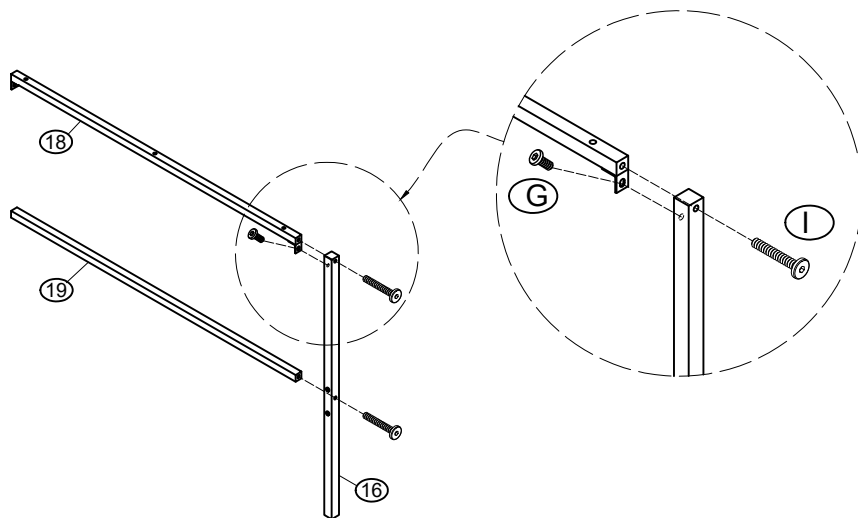
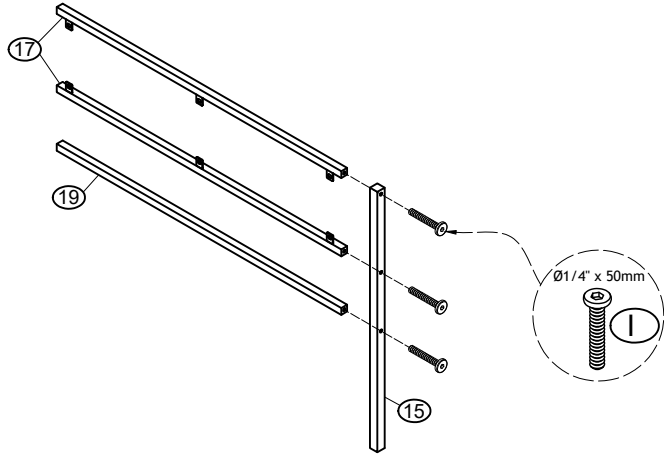

Ø1/4" x 50mm
ⓑ 5PCS



M4
ⓓ 1PC



STEP 14

Ø1/4" x 14mm
ⓐ 1PCS

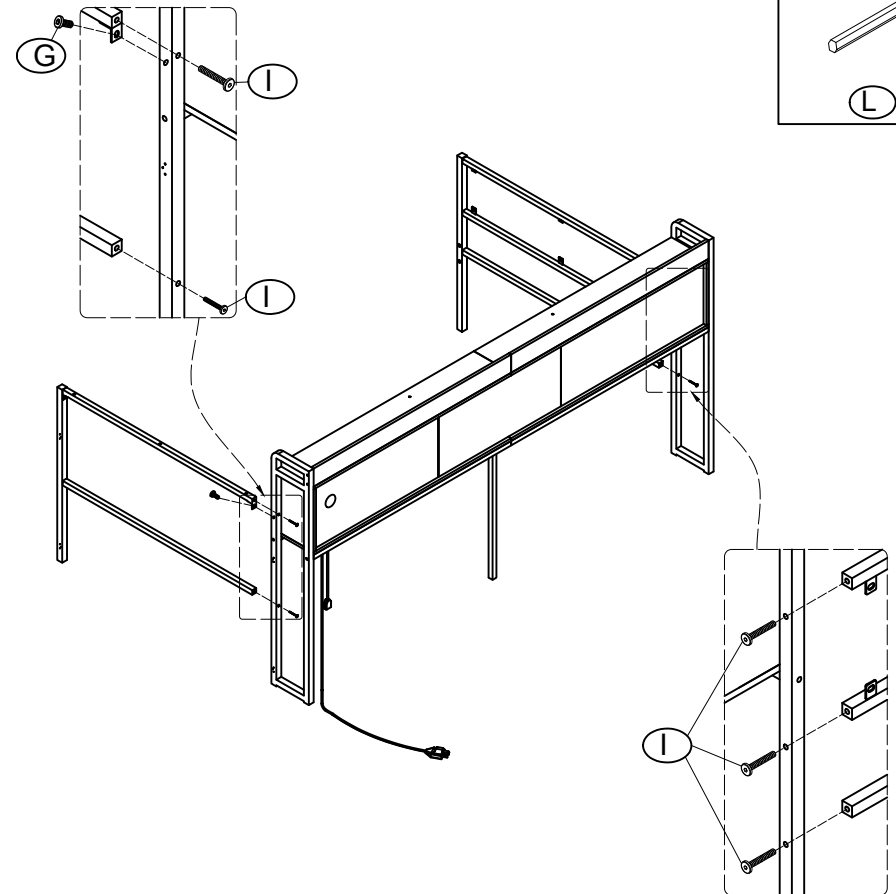

Ø1/4" x 50mm
ⓑ 5PCS

M4
ⓓ 1PC

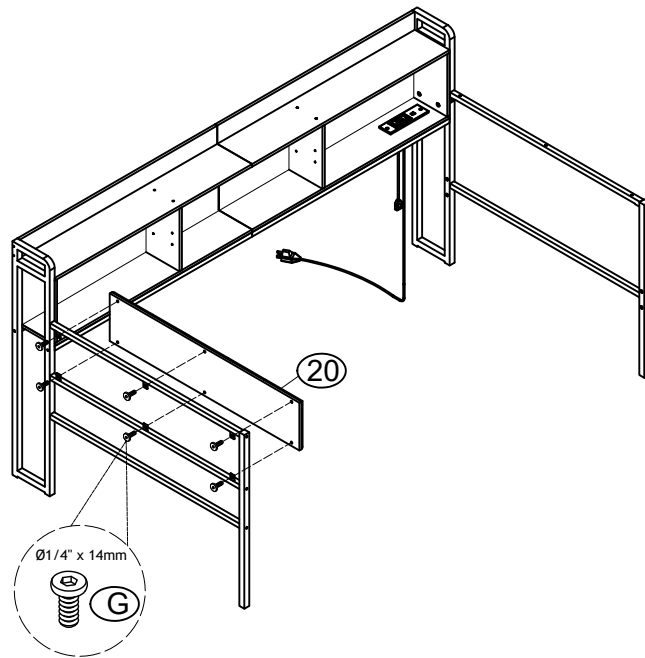

Montageanleitung für Bettgestell

STEP 15



Ø1/4" x 14mm

(G) 6PCS



M4

(L) 1PC

STEP 16

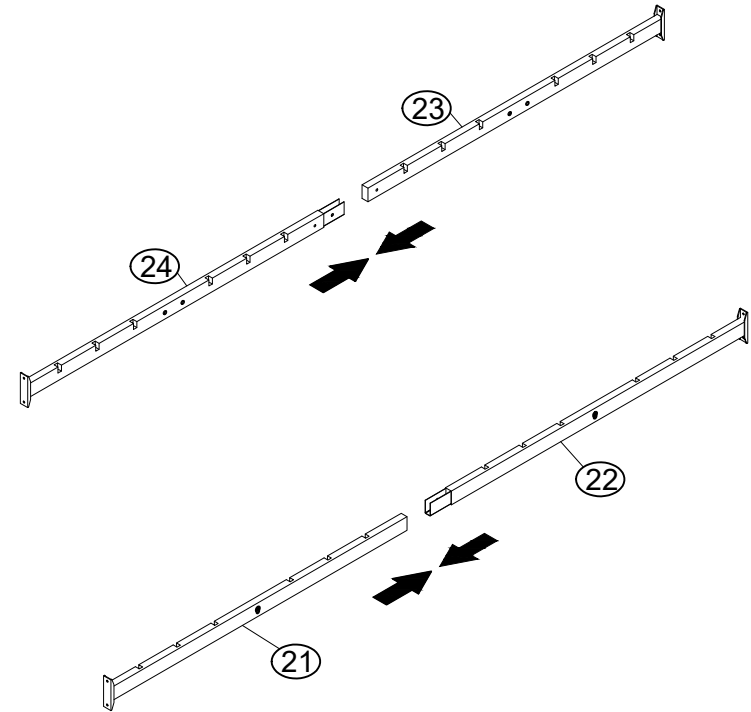

Montageanleitung für Bettgestell

STEP 17

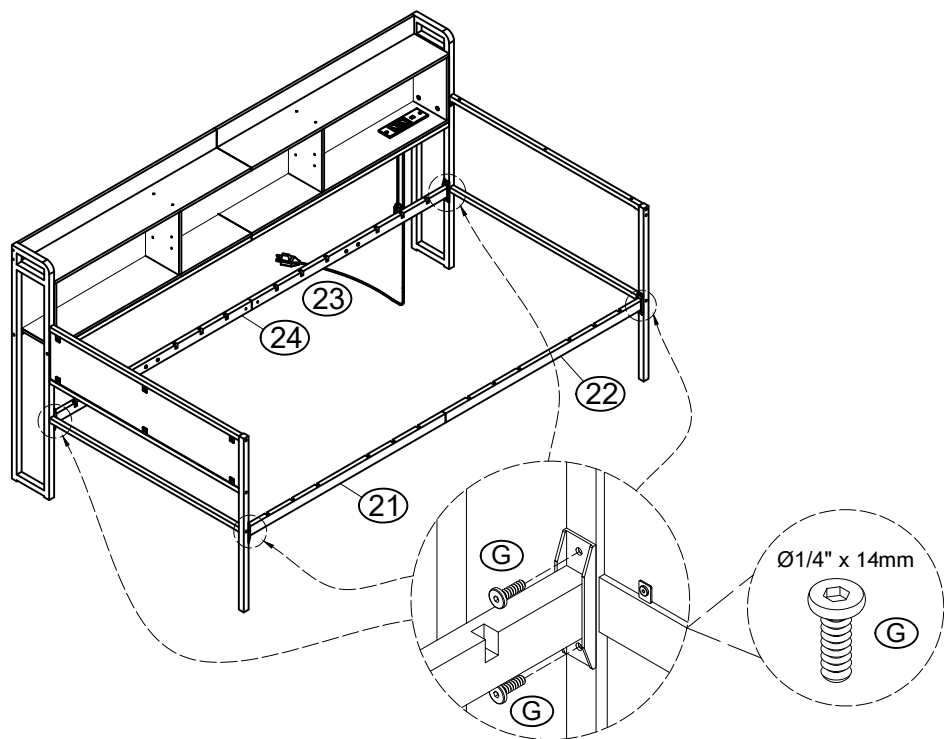
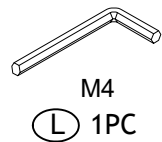
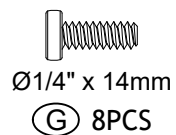

STEP 18

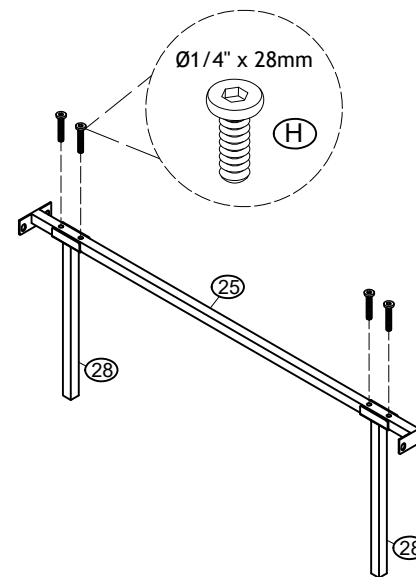
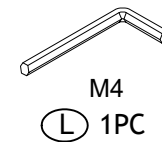
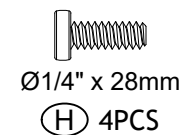

Montageanleitung für Bettgestell

STEP 19

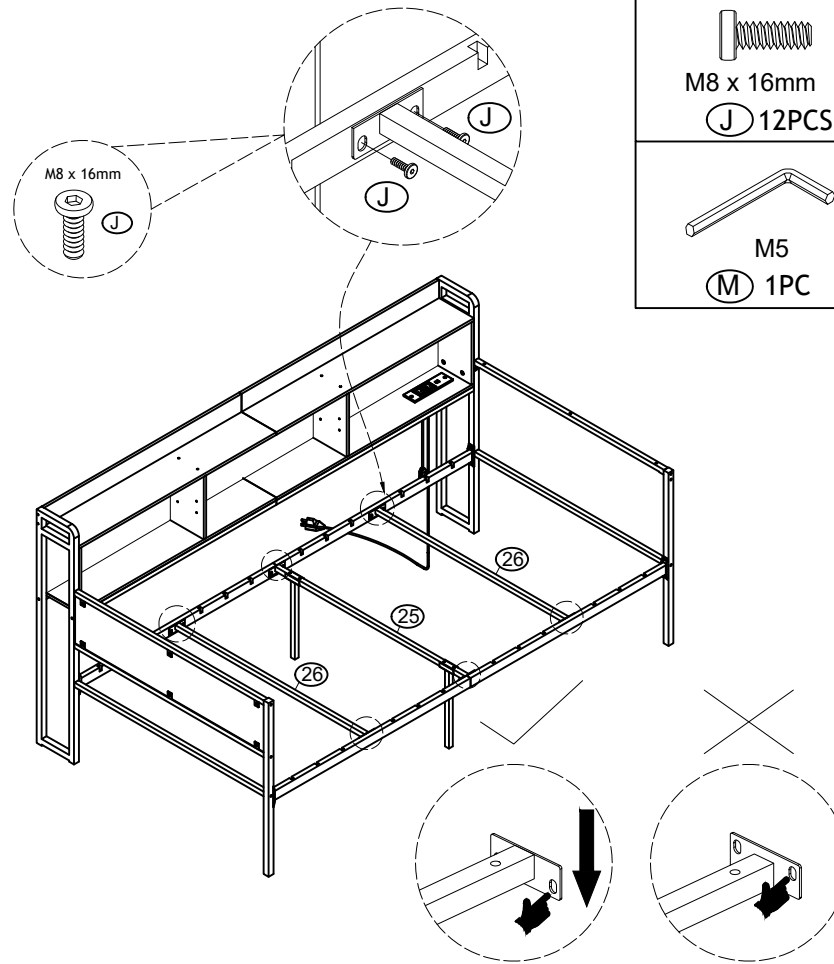

ATTENTION: This metal plate is on the bottom instead of on top. Don't install it wrongly.

Français
Remarque : Cette plaque métallique doit être installée en bas et non au sommet. Ne l'installez pas de manière incorrecte.

Italiano
Nota: Questa lamina metallica va installata in basso, non in alto. Non installarla erroneamente.

Deutsch
Hinweis: Diese Metallplatte befindet sich am Boden und darf nicht an der Oberseite installiert werden. Installieren Sie sie nicht falsch.

Español
Nota: Esta placa metálica se instala en la parte inferior, no en la parte superior. No instale incorrectamente.

STEP 20

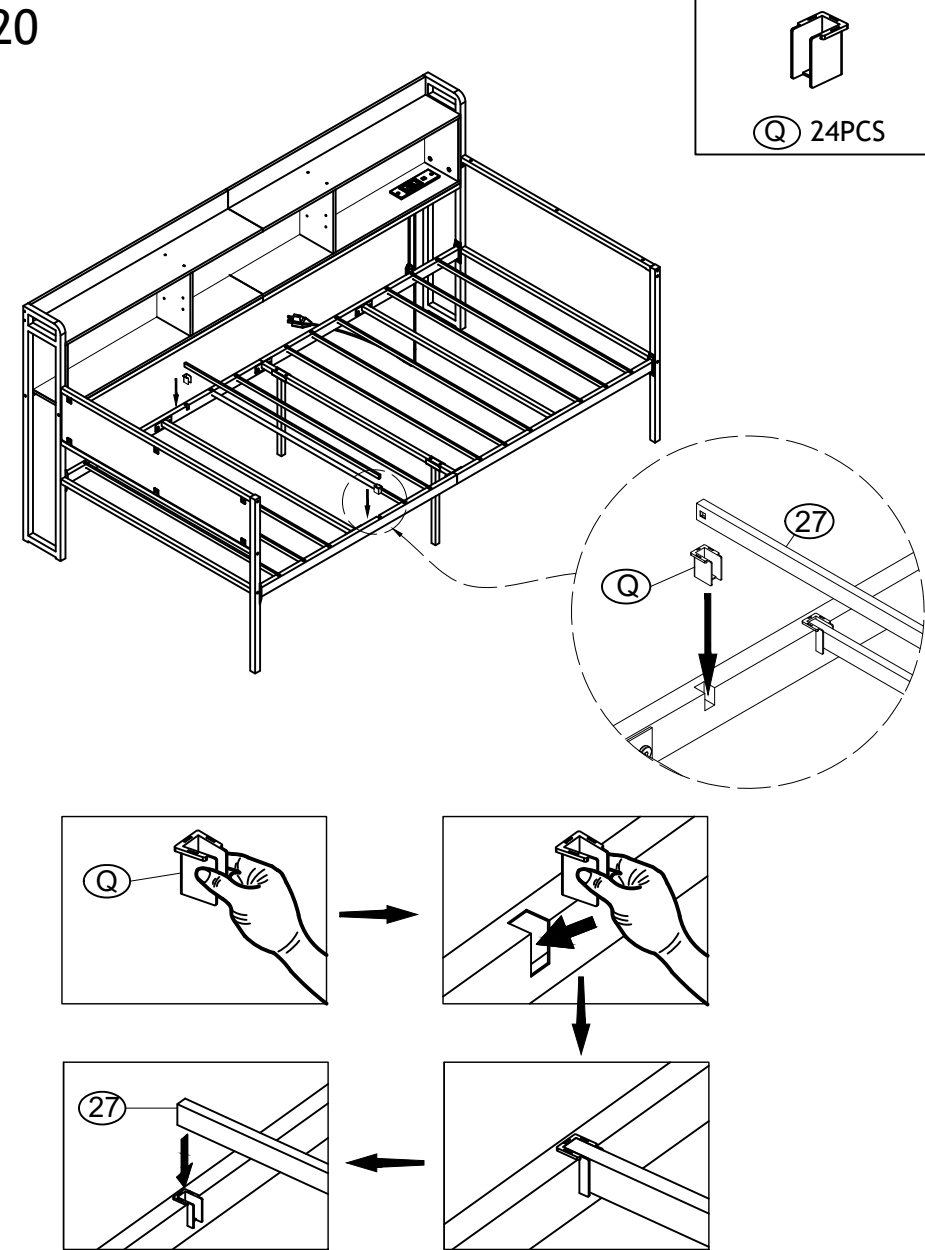

Montageanleitung für Bettgestell

STEP 21

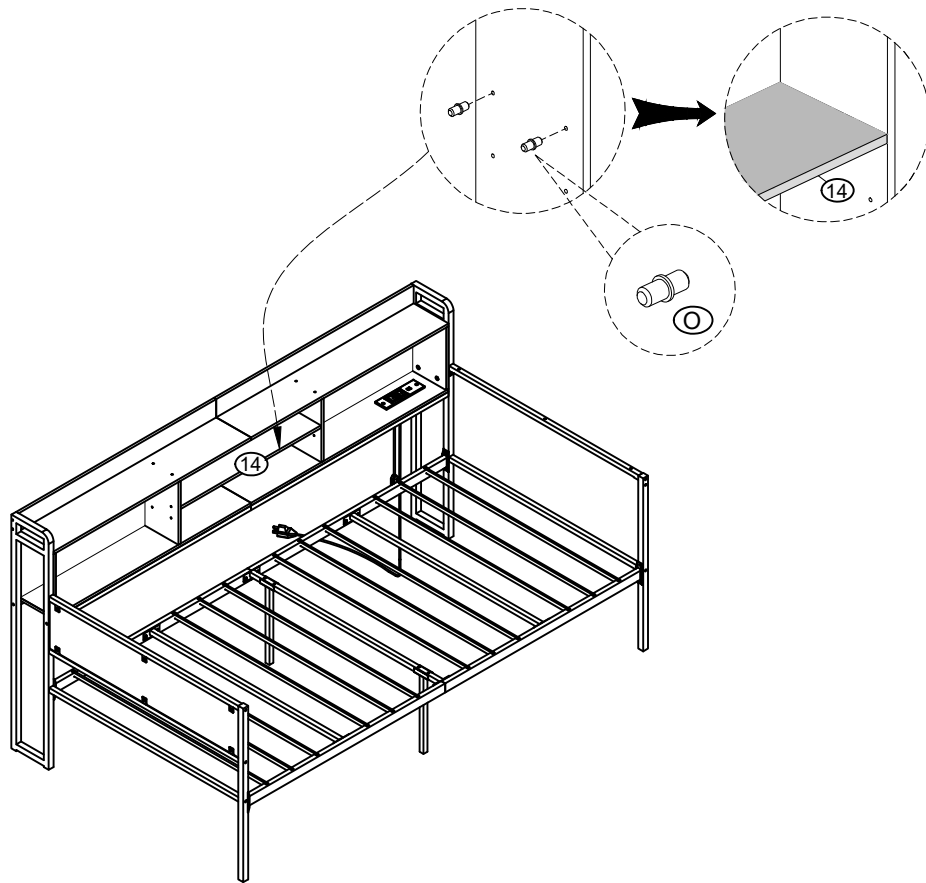
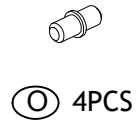

STEP 22

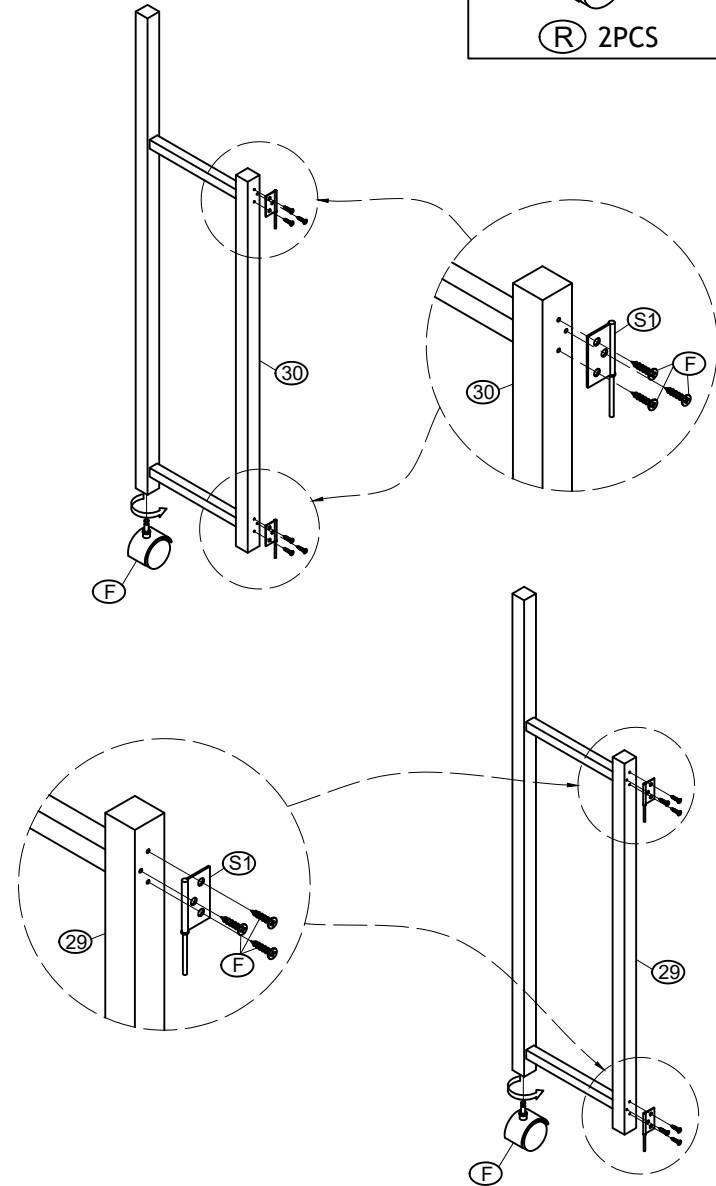
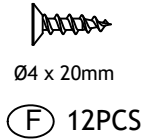
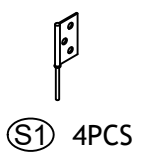
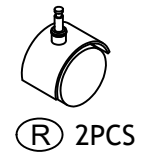

Montageanleitung für Bettgestell

STEP 23

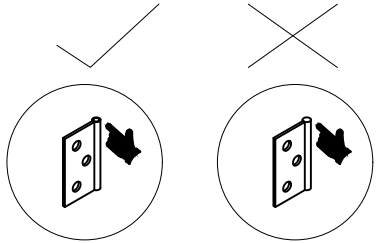

Holes facing up

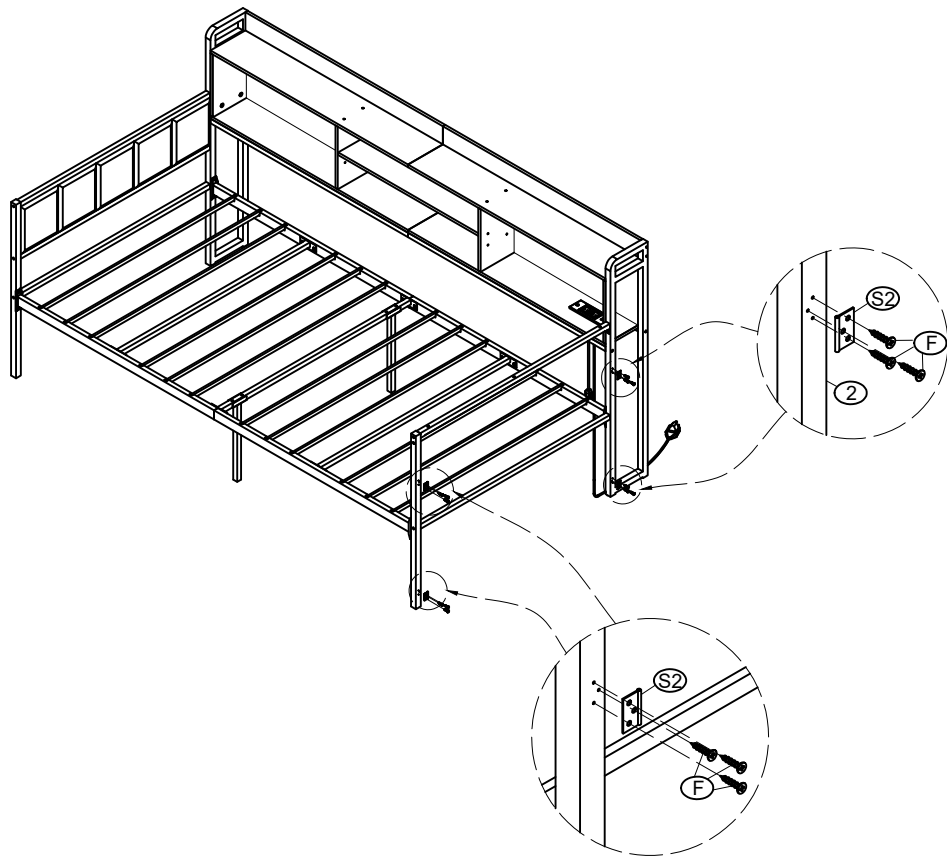
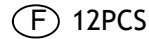
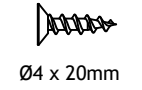

STEP 24

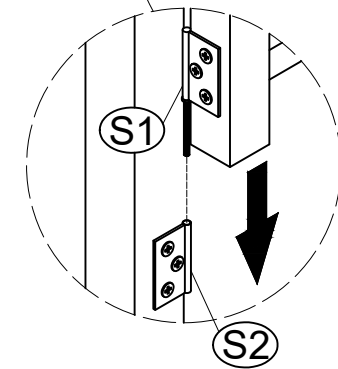
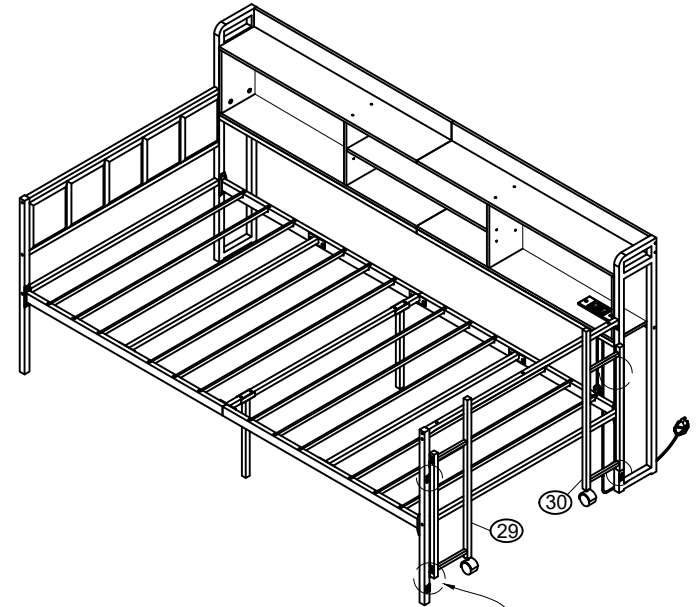

Montageanleitung für Bettgestell

STEP 25



Ø1/4" x 16mm

U 2PCS



T 3PCS

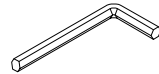

M4

L 1PC



Ø4 x 10mm

D 18PCS

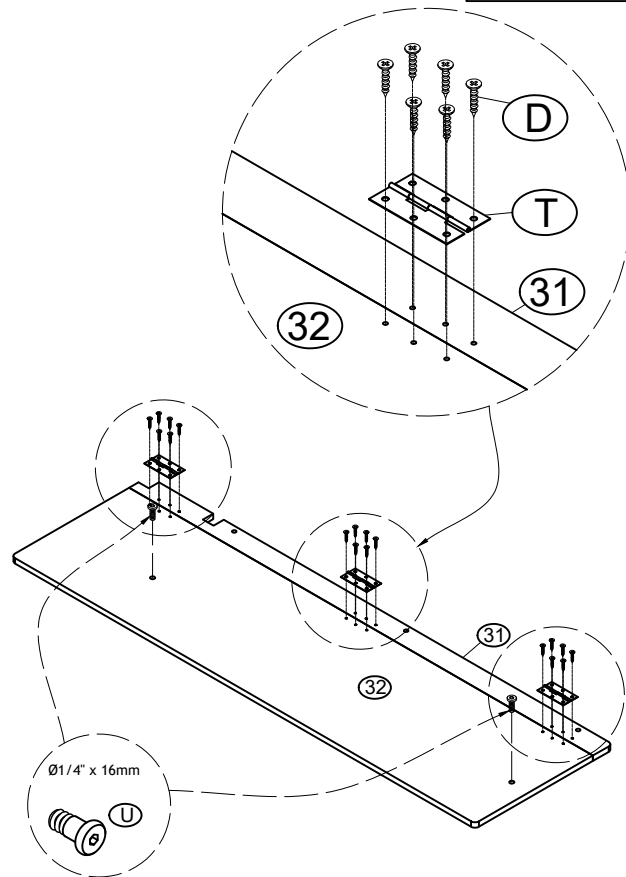

STEP 26



Ø1/4" x 28mm

H 3PCS



M4

L 1PC

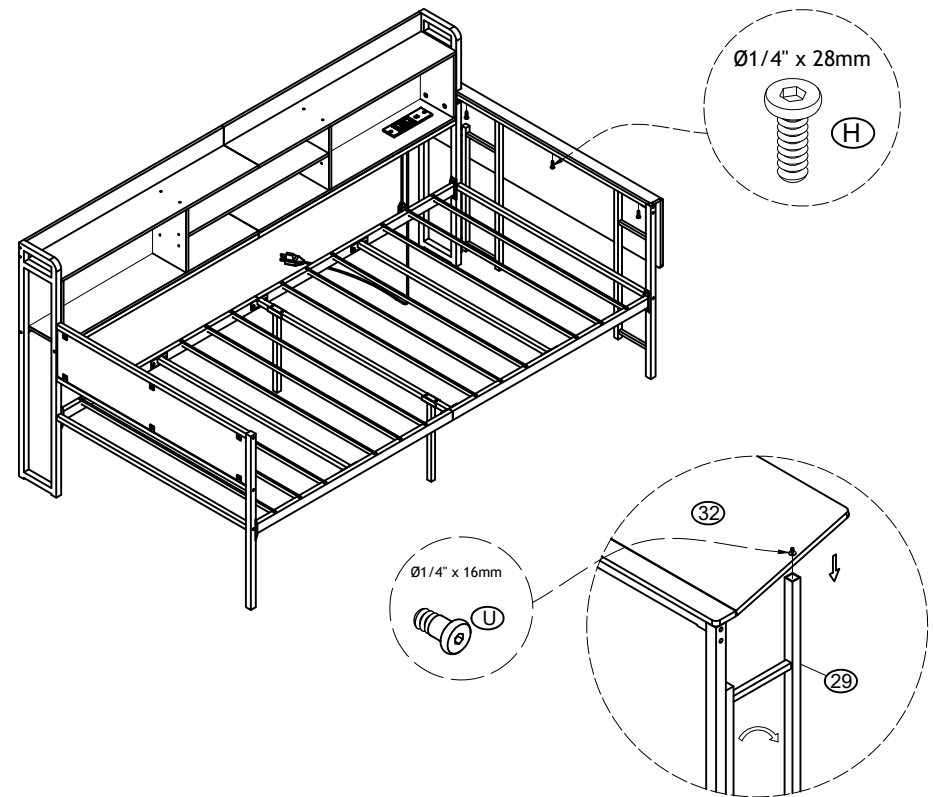

When using the tabletop, snap the head of screw V into the tube of parts 29 and 30

Montageanleitung für Bettgestell

STEP 27

Expand the drawer frame

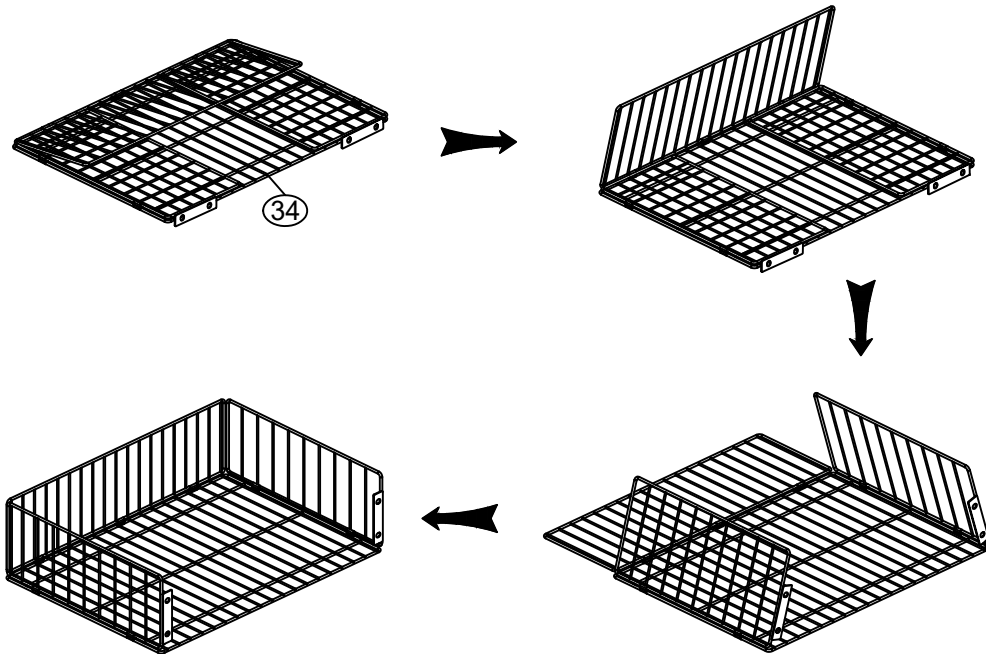

x 2

STEP 28





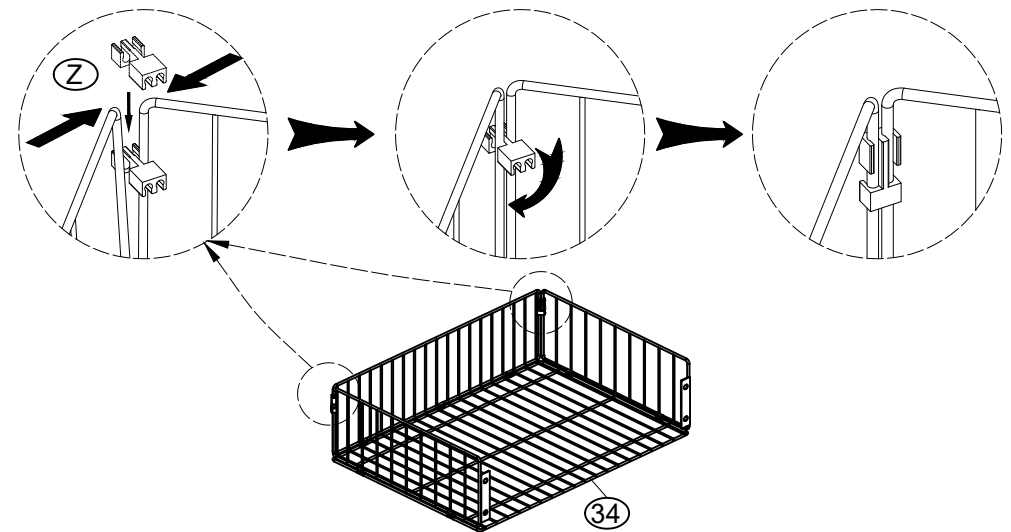

Z 4PCS



x 2

Montageanleitung für Bettgestell

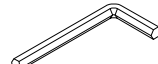
STEP 31

 Ø1/4" x 11mm E 2PCS	 Ø1/4" x 16mm U 2PCS
 M4 L 1PC	 Y 2PCS

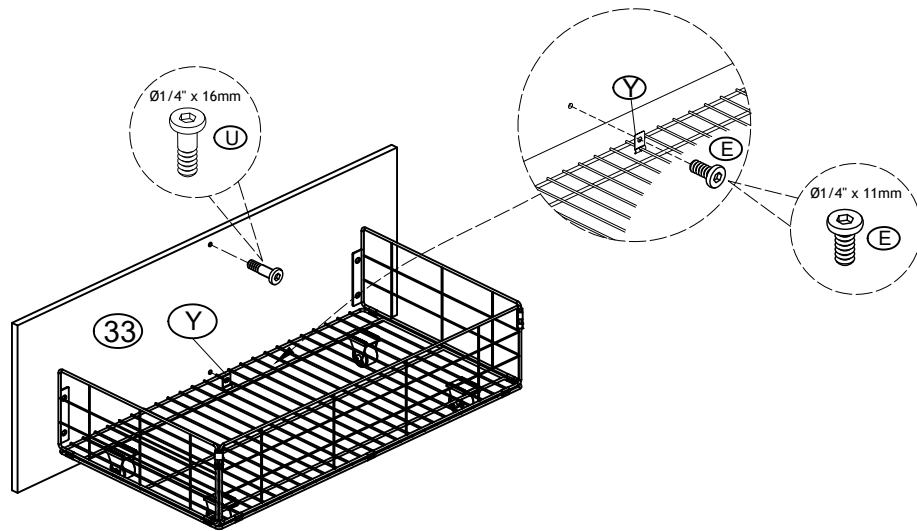

x 2

STEP 32

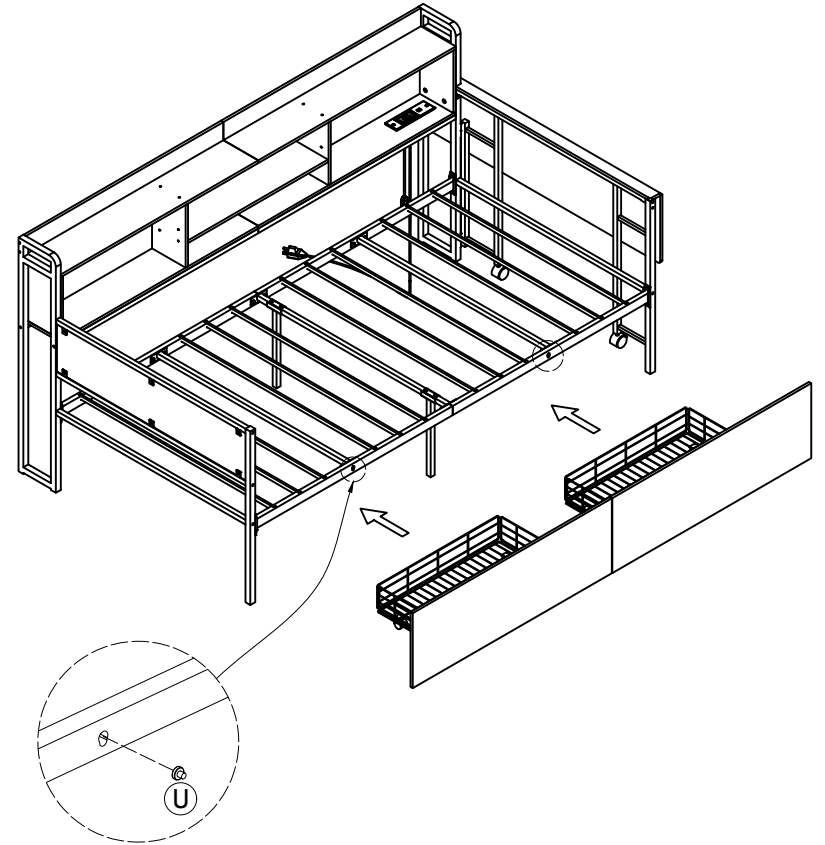

Instructions for assembling the LED strip

STEP 33



(X) 1PC



(AA) 1PC

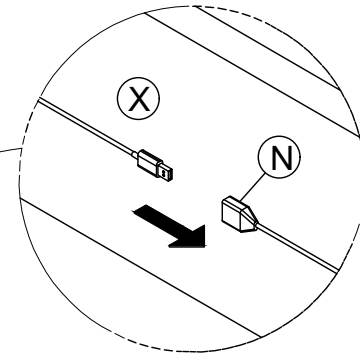
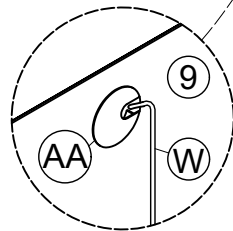
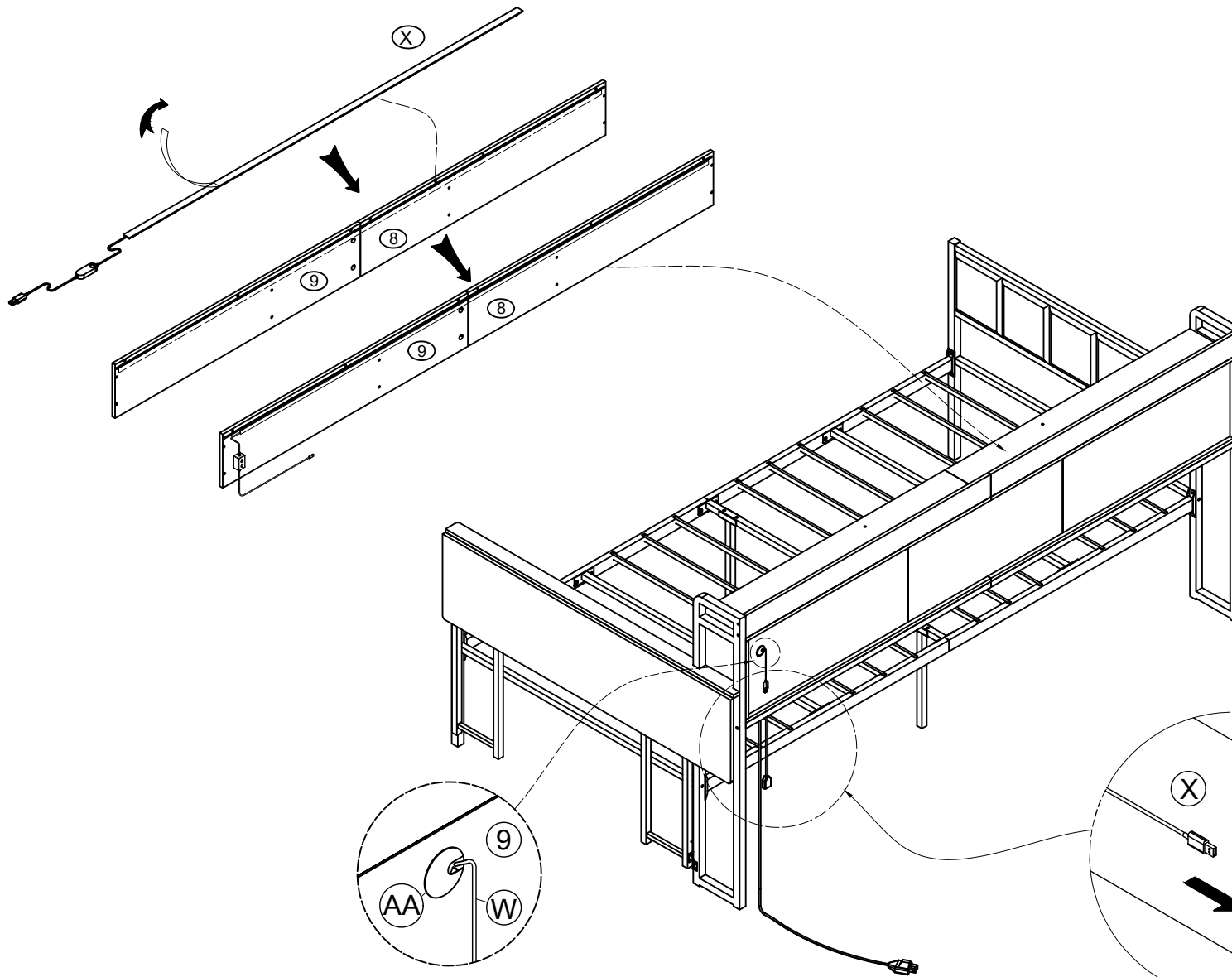

Verification of Compliance

Verification No.: MK23020083-P01E01

Name and address of Applicant:
Shenzhen HONGZHENG Technology Co., LTD
Shenzhen baoan district rock street industrial science and technology industrial park of 2 Haitian lanyu 3 5 floor of A

Name and address of Manufacturer:
Shenzhen HONGZHENG Technology Co., LTD
Shenzhen baoan district rock street industrial science and technology industrial park of 2 Haitian lanyu 3 5 floor of A

Product name: Lamp strip

Rated: 5V $\overline{\text{=}}$ 1A

Product model(s): HZY-2835-120D-12V, HZY-2835-30D-5V, HZY-2835-60D-5V, HZY-2835-120D-5V, HZY-2835-60D-12V, HZY-2835-60D-24V, HZY-2835-120D-24V, HZY-2835RGB-60D-5V, HZY-2835RGB-60D-12V, HZY-5050-30D-5V, HZY-5050-60D-5V, HZY-5050-30D-12V, HZY-5050-60D-12V, HZY-5050-60D-24V, HZY-5050RGB-30D-5V, HZY-5050RGB-60D-5V, HZY-5050RGB-30D-12V, HZY-5050RGB-60D-12V, HZY-5050RGB-60D-24V

Product trademark: N/A

This verification confirms that the product meets the requirements of the following standard.
The conformity was demonstrated based on following standard(s) listed by European Commission as harmonized with EMC Directive 2014/30/EU.

EN IEC 55015:2019+A11:2020

IEC 61547:2020

The verification has been carried out in accordance with individual rules and conditions agreed with the applicant. Evaluation has been carried out in accordance with:

Test report(s) No.: MK23020083-P01E01

Test conducted by: TMC Testing Services (Shenzhen) Co., Ltd.

Verification issue date: February 25, 2023

Notes:

This verification refers to the above mentioned product and its conformity in regards of above mentioned standard(s) was proven on test sample.

This verification does not imply meeting all essential requirements, assessment of the series-production or any other restricted Notified Bodies conformity assessment procedure appropriate for the product.

This verification holder shall use this verification in connection to verification of conformity and technical data relevant for the product the verification was issued.

TMC Testing Services (Shenzhen) Co., Ltd.

t:86-755-866642861 cert@tmc-lab.com www.tmc-lab.com

1st Floor, Block A1, Zone A, Xinchidai Gongrong Industrial Park, No. 2, Shihuan Road, Shiyuan Street, Baoan District, Shenzhen, China



Certificate of Conformity

No.: LP24060215C01-01

The following products have been tested by us with the listed standards and found in compliance with the council EMC directive 2014/30/EU. It is demonstrative for the compliance with this EMC Directive.

Applicant : Dongguan Yali Electric Appliance Co.,Ltd
Address : 8 / F, Building 9, No. 6, Yuyuan 4th Road, Yuyuan Industrial Zone, Huangjiang Town, Dongguan City, Guangdong Province
Product : Strip power supply
Model No. : YL-SKCE-901, YL-SKCE-902, YL-SKCE-903, YL-SKCE-905, YL-SKCE-906, YL-SKCE-907, YL-SKCE-908, YL-SKCE-909, YL-SKCE-901A, YL-SKCE-902A, YL-SKCE-903A, YL-SKCE-905A, YL-SKCE-906A, YL-SKCE-907A, YL-SKCE-908A, YL-SKCE-909A
Test Standards : EN 55032:2015+A11:2020+A1:2020
EN 55035:2017+A11:2020
EN IEC 61000-3-2:2019+A1:2021
EN 61000-3-3:2013+A1:2019+A2:2021

CE

The CE marking may be used if all relevant and affactive EC Directives/Regulations are complied with.

Manager: Frank Shen
Date: October 31, 2024

Dongguan Lepont Testing Service Co., Ltd.

Tel.:86-769-83086888 Fax.:86-769-83096886

Room 102, Building 11, No.7, Houjie Science And Technology Avenue, Houjie, Dongguan, Guangdong, China

The statement is based on a single evaluation of one sample of above mentioned products. It does not imply an assessment of the whole production and does not permit the use of the test lab's logo.



Product Service

Attestation of Conformity

No. N8A 129388 0002 Rev. 00

Holder of Attestation: Dongguan Yali Electric
Appliance Co., Ltd.

8/F, Building 9, No. 6, Yuyuan 4th Road
Yuyuan Industrial Zone, Huangjiang Town
523750 Dongguan City, Guangdong Province
PEOPLE'S REPUBLIC OF CHINA

Product: Socket-outlets

This Attestation of Conformity is issued on a voluntary basis according to the Low Voltage Directive 2014/35/EU relating to electrical equipment designed for use within certain voltage limits. It confirms that the listed equipment complies with the principal protection requirements of the directive and is based on the technical specifications applicable at the time of issuance. It refers only to the particular sample submitted for conformity assessment. For details see: www.tuvsud.com/ps-cert

Test report no.: 6810024020601

Date, 2024-12-04

(Michael Xu)

Page 1 of 2

This Attestation does not replace the regulatory EU Declaration of Conformity (DoC) and does not allow for CE marking. After preparation of the necessary documentation and establishing compliance to requirements of all applicable directives, the manufacturer may sign a DoC and apply the CE marking. The DoC is issued under the sole responsibility of the manufacturer.

Attestation of Conformity

No. N8A 129388 0002 Rev. 00



Product Service

Model(s):

YL-SKCE-901, YL-SKCE-901A, YL-SKCE-901A-PD20W,
YL-SKCE-902, YL-SKCE-902A, YL-SKCE-902A-PD20W,
YL-SKCE-903, YL-SKCE-903A, YL-SKCE-903A-PD20W,
YL-SKCE-905, YL-SKCE-905A, YL-SKCE-905A-PD20W,
YL-SKCE-906, YL-SKCE-906A, YL-SKCE-906A-PD20W,
YL-SKCE-907, YL-SKCE-907A, YL-SKCE-907A-PD20W,
YL-SKCE-908, YL-SKCE-908A, YL-SKCE-908A-PD20W,
YL-SKCE-909, YL-SKCE-909A, YL-SKCE-909A-PD20W

Parameters:

Rated voltage: 250Vac
Rated frequency: 50/60Hz
Rated current: 16A
Protection class: I
Degree of protection: IP20
Type of cable: H05VV-F 3G1.5mm²

Tested according to:

DIN VDE 0620-1:2021
DIN VDE 0620-2-1:2021/A1:2023

Page 2 of 2

This Attestation does not replace the regulatory EU Declaration of Conformity (DoC) and does not allow for CE marking. After preparation of the necessary documentation and establishing compliance to requirements of all applicable directives, the manufacturer may sign a DoC and apply the CE marking. The DoC is issued under the sole responsibility of the manufacturer.