

# Montageanleitung | Instructions de montage Assembly Instructions | Instrucciones de montaje

SKU NUMBER: WF321250

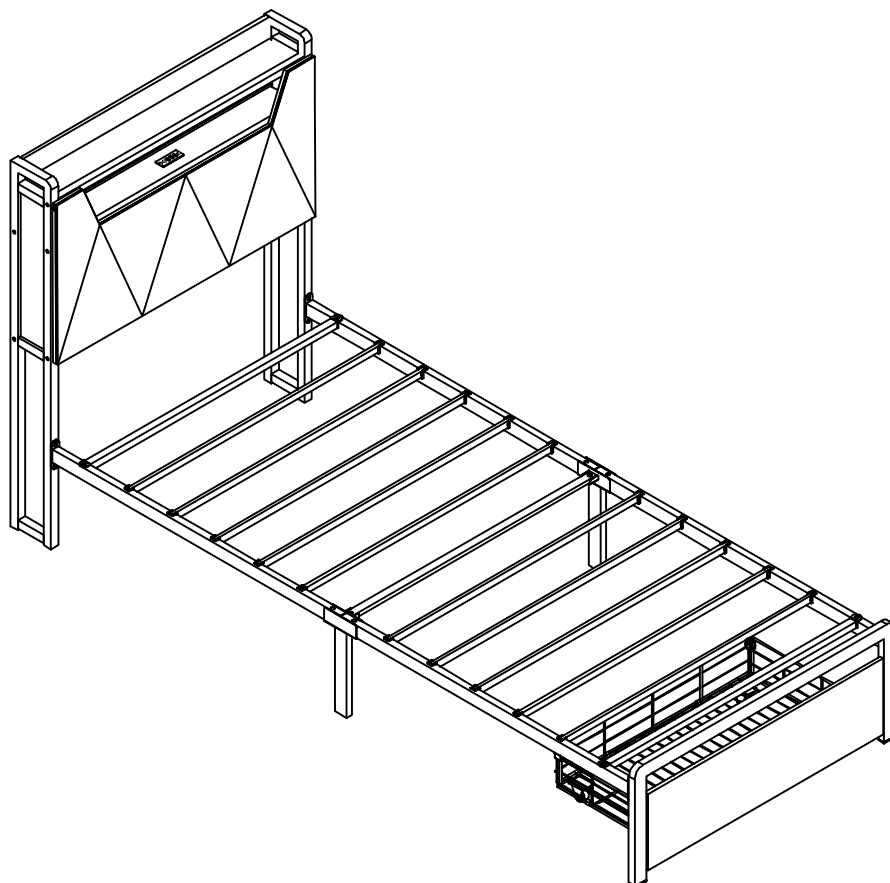

## English

### IMPORTANT ! KEEP FOR FUTURE REFERENCE : READ CAREFULLY

- To be assembled by an adult. Assembly must be checked by an adult before use
- WARNING ! Keep all screws, small parts and plastic bags out of the reach of children
- Properly identify all parts before assembling
- Never use your item if any of its parts are broken or missing
- Should any problems arise, please contact our After Sales Service
- Manufacturer's instructions shall be followed at all times
- Care: Clean with a soft, dry cloth. In case of larger stains, carefully rub with a slightly damp, non-abrasive sponge
- Avoid the risk of fire by not placing furniture near sources of ignition or hot items
- Do not jump on the bed

## Deutsch

### WICHTIG ! ZUM SPÄTEREN NACHSCHLAGEN AUFBEWAHREN: SORGFÄLTIG LESEN

- Muss von einem Erwachsenen zusammengebaut werden. Der Zusammenbau muss vor dem Gebrauch von einem Erwachsenen überprüft werden
  - WARNUNG! Bewahren Sie alle Schrauben, Kleinteile und Plastikbeutel außerhalb der Reichweite von Kindern auf
  - Kennzeichnen Sie vor dem Zusammenbau alle Teile richtig
  - Benutzen Sie Ihren Artikel niemals, wenn Teile gebrochen sind oder fehlen
  - Sollten Probleme auftreten, wenden Sie sich bitte an unseren Kundendienst
  - Die Anweisungen des Herstellers sind stets zu befolgen
  - Pflege: Mit einem weichen, trockenen Tuch reinigen. Bei größeren Flecken vorsichtig mit einem leicht feuchten, nicht scheuernden Schwamm abreiben. nicht scheuernden Schwamm
  - Vermeiden Sie die Gefahr eines Brandes, indem Sie die Möbel nicht in der Nähe von Zündquellen oder heißen Gegenständen aufstellen
- Nicht auf das Bett springen

## Français

### IMPORTANT ! CONSERVER POUR RÉFÉRENCE ULTÉRIEURE : LIRE ATTENTIVEMENT

- Le montage doit être effectué par un adulte. Le montage doit être vérifié par un adulte avant Utilisation
- ATTENTION ! Tenir les vis, les petites pièces et les sachets en plastique hors de portée des enfants
- Identifiez correctement toutes les pièces avant de les assembler
- N'utilisez jamais votre article si l'une de ses pièces est cassée ou manquante
- En cas de problème, veuillez contacter notre service après-vente
- Les instructions du fabricant doivent être respectées à tout moment
- Entretien : nettoyer avec un chiffon doux et sec. En cas de taches plus importantes, frotter soigneusement avec une éponge non abrasive légèrement humide. légèrement humide et non Abrasive
- Évitez les risques d'incendie en ne plaçant pas les meubles à proximité de sources d'inflammation ou d'objets chauds
- Ne pas sauter sur le lit

**Italiano**

**IMPORTANTE! CONSERVARE PER RIFERIMENTO FUTURO: LEGGERE ATTENTAMENTE**

- Deve essere assemblato da un adulto. L'assemblaggio deve essere controllato da un adulto prima dell'uso
- **ATTENZIONE!** Tenere tutte le viti, le piccole parti e i sacchetti di plastica fuori dalla portata dei bambini
- Identificare correttamente tutte le parti prima dell'assemblaggio
- Non utilizzare mai l'articolo se alcune parti sono rotte o mancanti
- In caso di problemi, si prega di contattare il nostro Servizio Post Vendita
- Le istruzioni del produttore devono essere sempre seguite
- Cura: Pulire con un panno morbido e asciutto. In caso di macchie più estese, strofinare accuratamente con una spugna leggermente umida e nonspugna leggermente umida e non abrasiva
- Evitare il rischio di incendio, non collocando i mobili vicino a fonti di accensione o a oggetti caldi
- Non saltare sul letto

**Español**





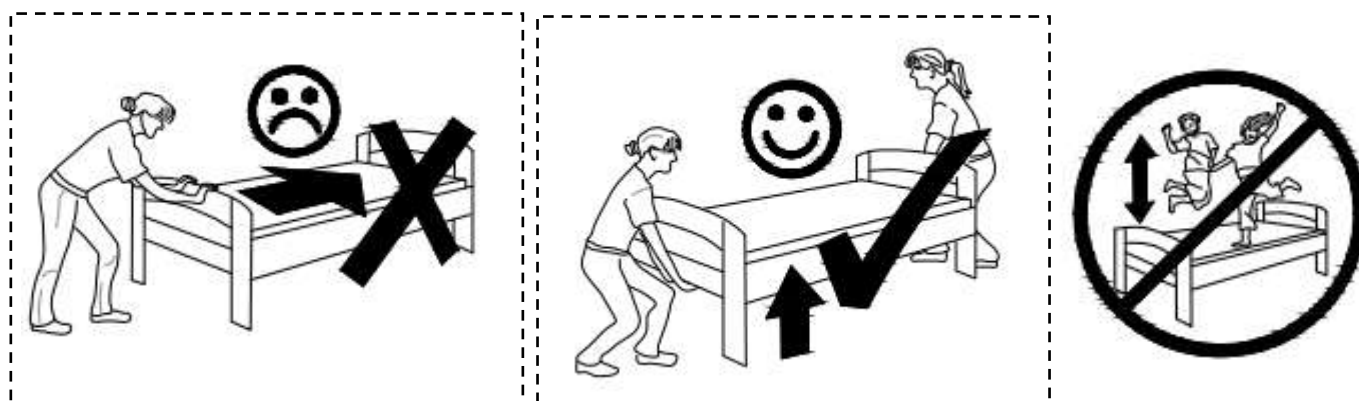

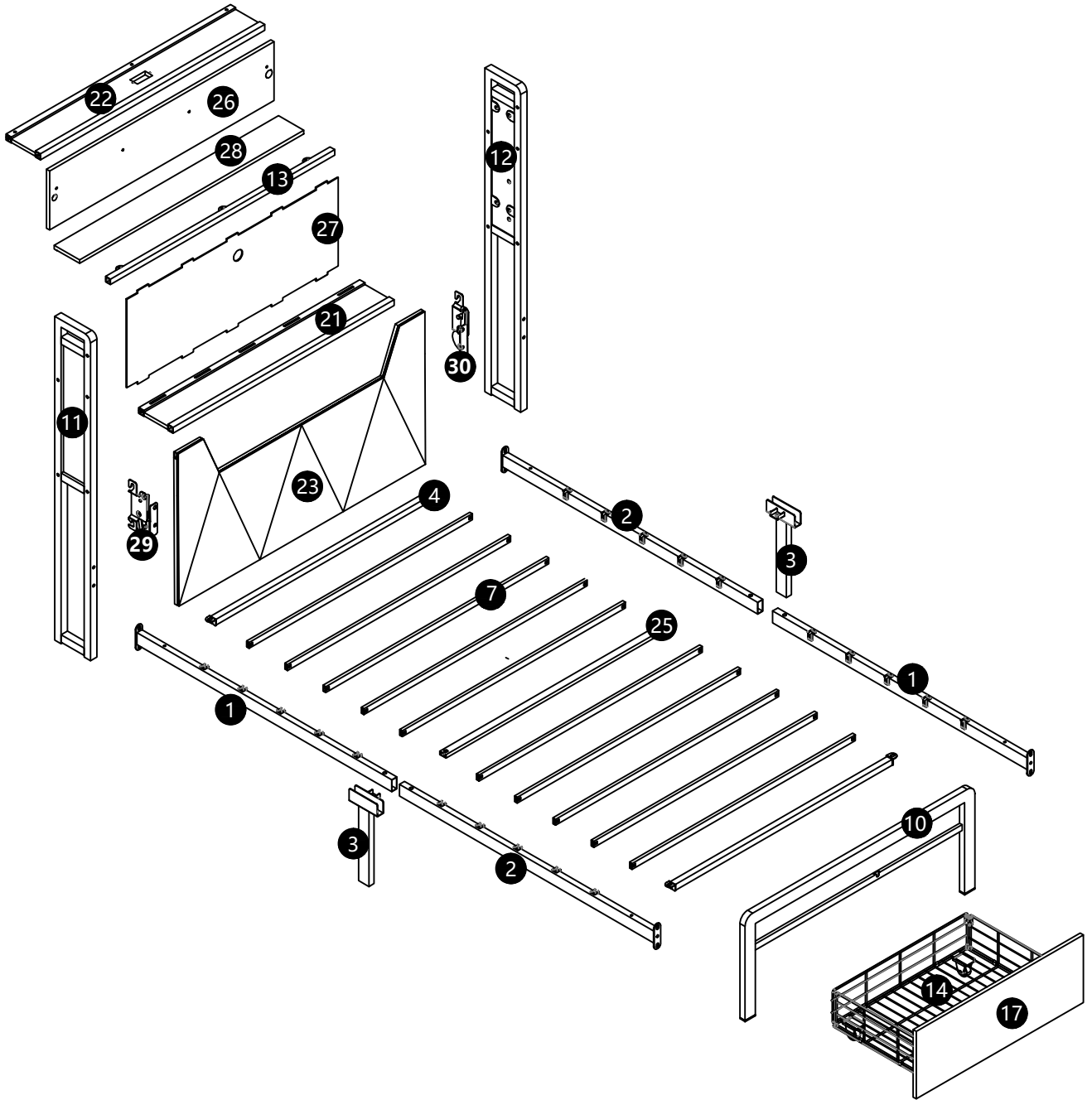
**¡ IMPORTANTE ! CONSERVELO PARA FUTURAS CONSULTAS: LEA ATENTAMENTE**

- Debe ser montado por un adulto. El montaje debe ser comprobado por un adulto antes del uso
- ADVERTENCIA Mantenga todos los tornillos, piezas pequeñas y bolsas de plástico fuera del alcance de los niños.
- Identifique correctamente todas las piezas antes de montarlas
  - Nunca utilice su artículo si alguna de sus piezas está rota o falta
  - Si surge algún problema, póngase en contacto con nuestro Servicio Postventa
  - Las instrucciones del fabricante deben seguirse en todo momento
  - Cuidado: Limpiar con un paño suave y seco. En caso de manchas más grandes, frote cuidadosamente con una esponja no abrasiva ligeramente humedecida.
  - Evite el riesgo de incendio no colocando los muebles cerca de fuentes de ignición u objetos calientes.
  - No saltar sobre la cama.

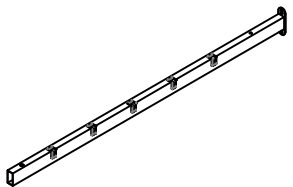

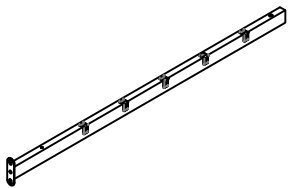

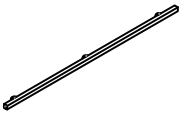
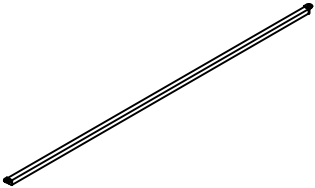
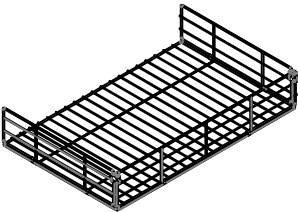
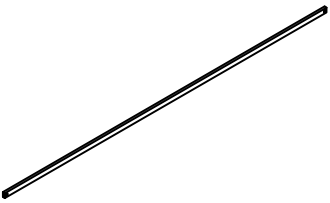
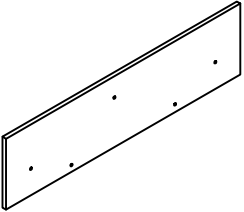
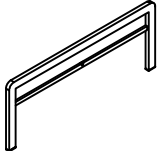





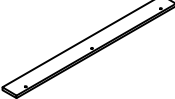
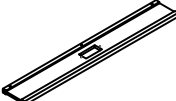

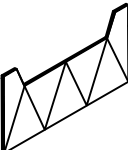
# WF321250

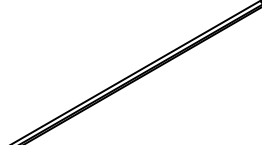
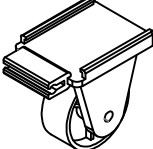
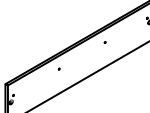
<b>1</b>		X2	<b>11</b>		X1
<b>2</b>		X2	<b>12</b>		X1
<b>3</b>		X2	<b>13</b>		X1
<b>4</b>		X2	<b>14</b>		X1
<b>7</b>		X10	<b>17</b>	 Drawer board	X1
<b>10</b>		X1	<b>19</b>	 Iron buckle	X4

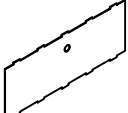
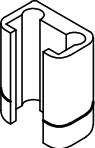
# WF321250



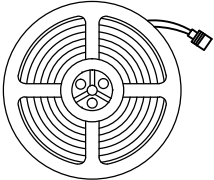
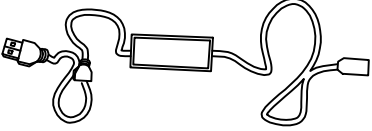
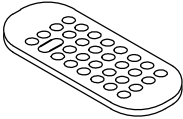



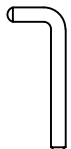

<b>21</b>		X1	<b>28</b>		X1
<b>22</b>		X1	<b>29</b>		X1
<b>23</b>		X1	<b>30</b>		X1
<b>25</b>		X1	<b>31</b>	 Pulley	X4
<b>26</b>		X1	<b>32</b>	 Black plastic buckle (A)	X2 +1
<b>27</b>		X1	<b>33</b>	 Black plastic buckle (B)	X2 +1

# WF321250

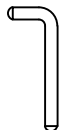
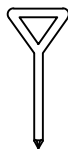
34	 light bar	X1			
35	 Light strip controller	X1			
36	 Remote control	X1			
37	 Strap magic tape	X4			

# Hardware List-Hardware-Liste-Liste du matériel

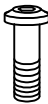
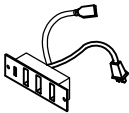
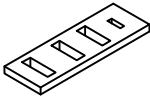
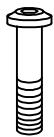
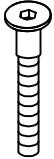
WF321250

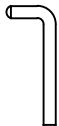
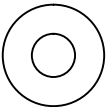
<b>A</b>	 M6*15	X4 +1	<b>H</b>	 M5 / M8	X1	<b>N</b>	 M3*12	X2
<b>B</b>	 M6*45	X10 +2	<b>I</b>	 M3 / M5	X1	<b>O</b>	 	X1
<b>C</b>	 M8*12	X12 +2	<b>J</b>	 M6*10	X3	<b>P</b>	 	X10 +2
<b>D</b>	 M8*20	X10 +2	<b>K</b>	 	X1	<b>S</b>	 	X1
<b>F</b>	 M8*48	X4	<b>L</b>	 M5*35	X8 +1	<b>R</b>	 M8*15	X1 +1
<b>G</b>	 M4 / M6	X1	<b>M</b>	 M8*φ22	X2			

1

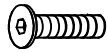

JX3pcs

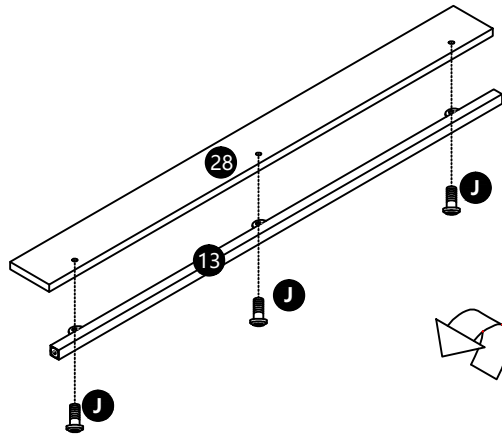

Back

2



NX2pcs

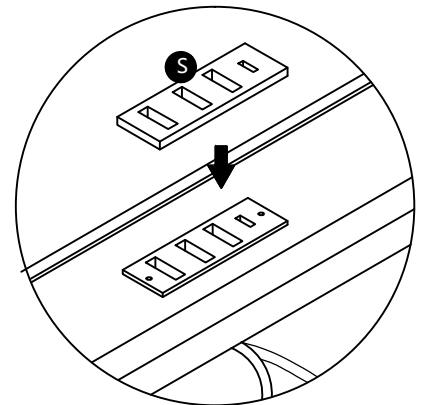
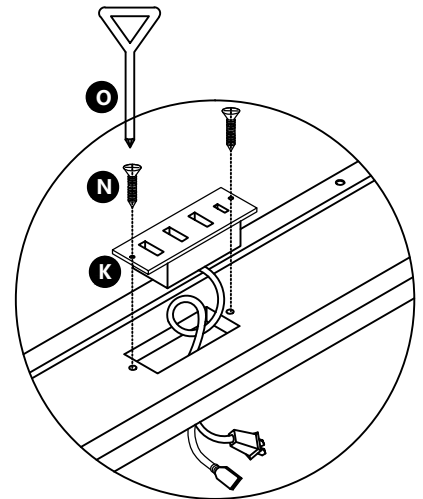
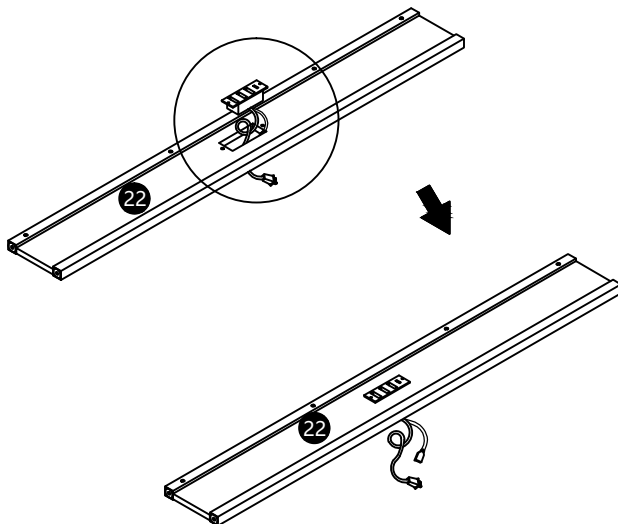

**3**

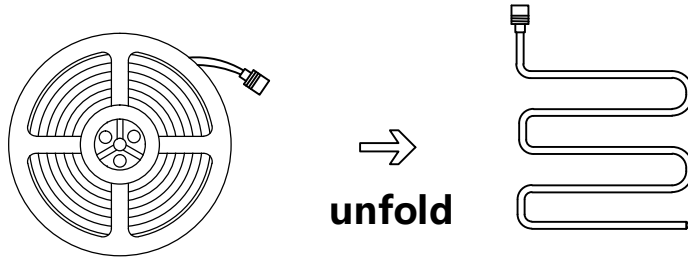

**34** light bar

**Stick the light strip on**

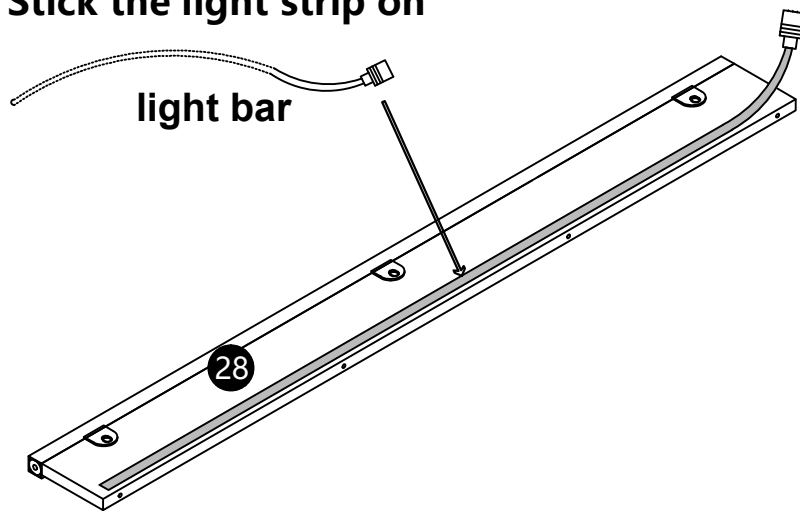

# 4

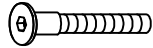

LX4pcs

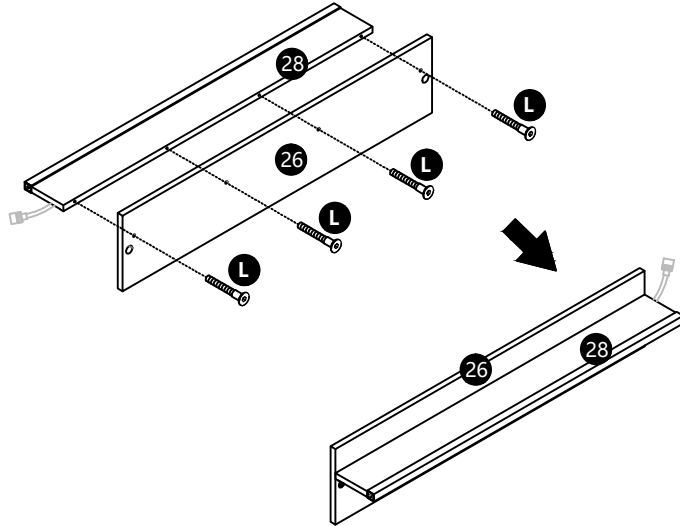

# 5

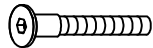

LX4pcs

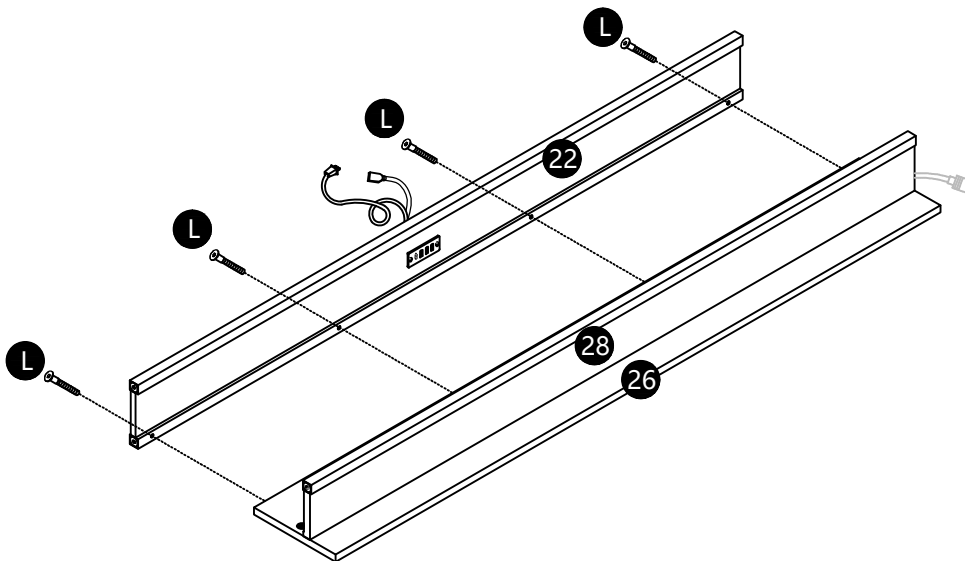

6

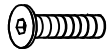

BX4pcs

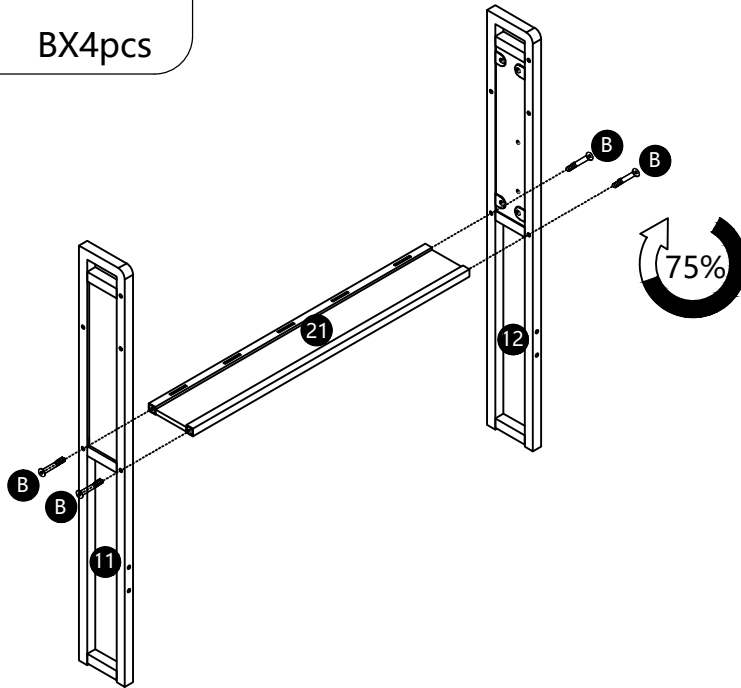

7



PX10pcs

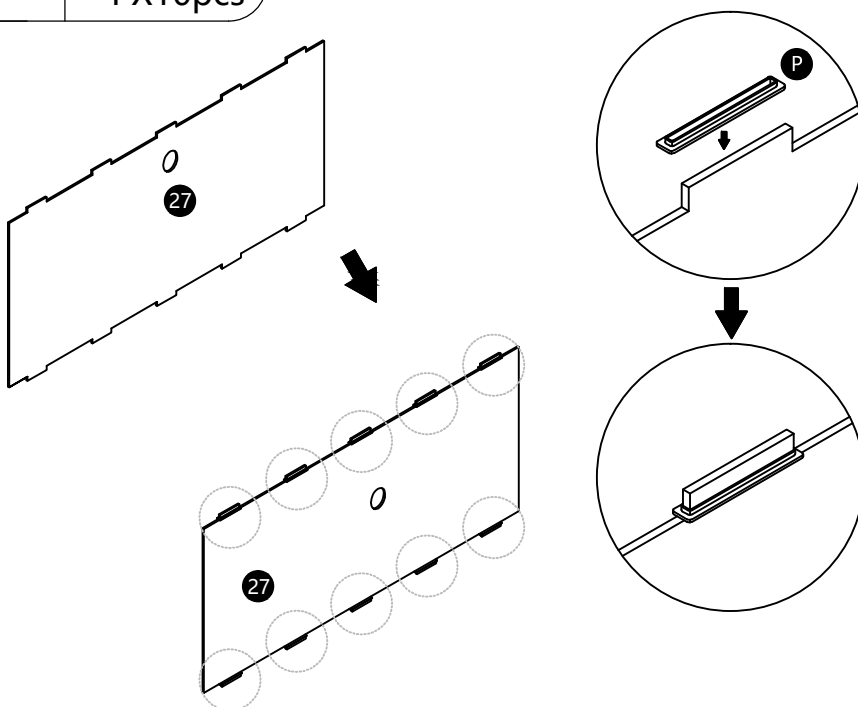

8

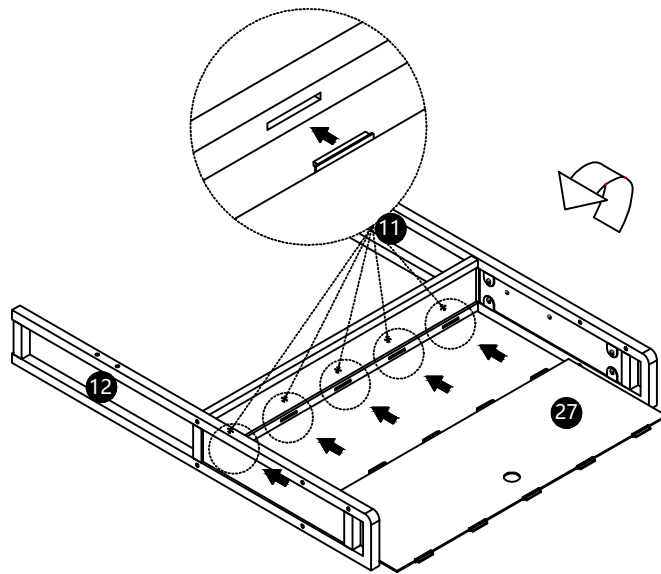

9



BX6pcs

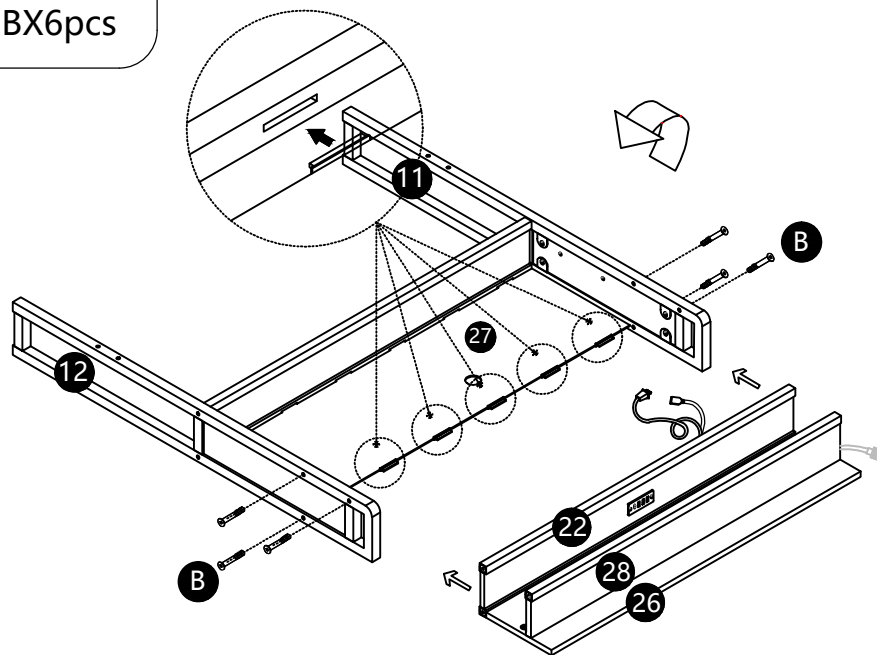

# 10

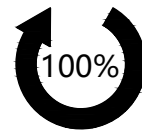
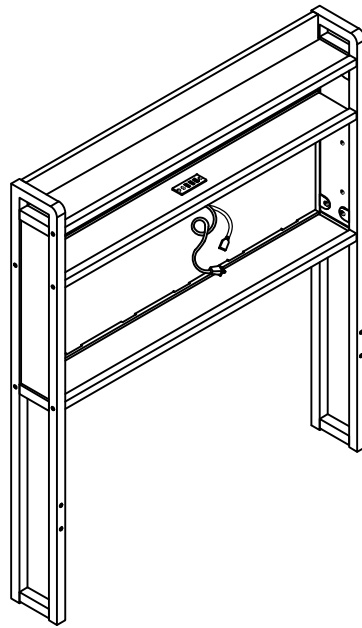

Tighten all screws  
Alle Schrauben anziehen  
Serrer toutes les vis  
Stringa tutte le viti  
Apriete todos los tornillos

# 11

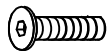

CX4pcs

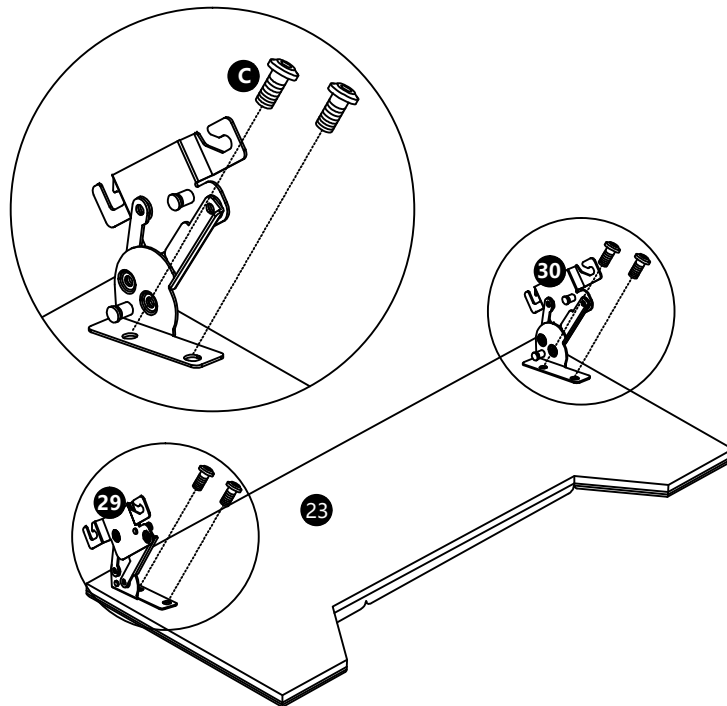

# 12



CX4pcs

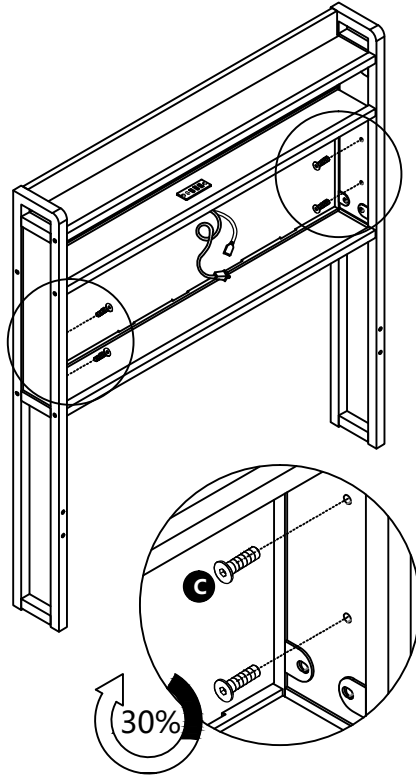

# 13

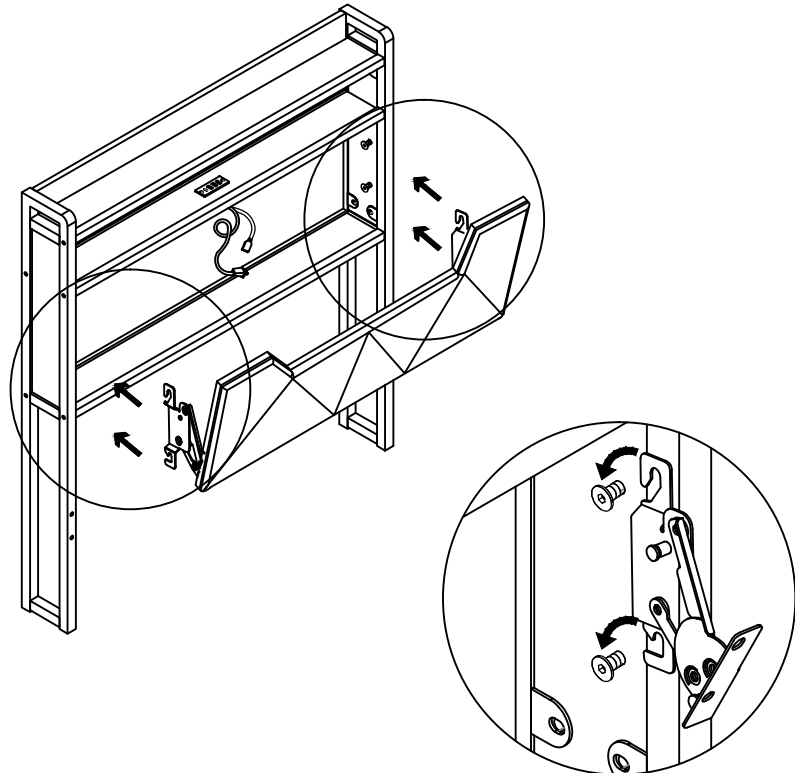

# 14



FX4pcs

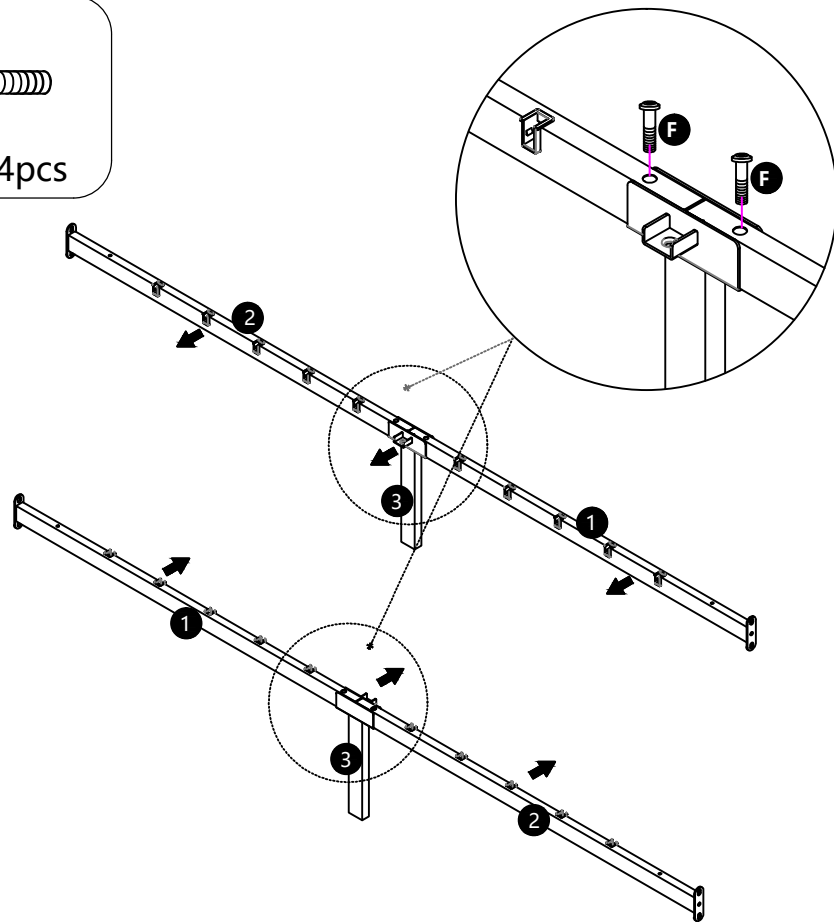

# 15

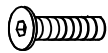

DX8pcs

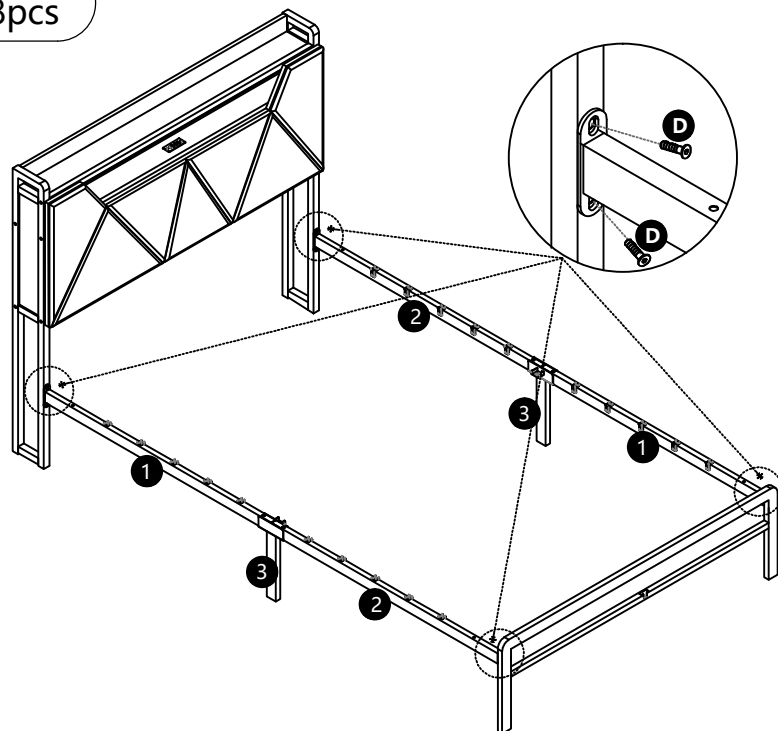

# 16



AX4pcs

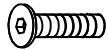

DX2pcs



MX2pcs

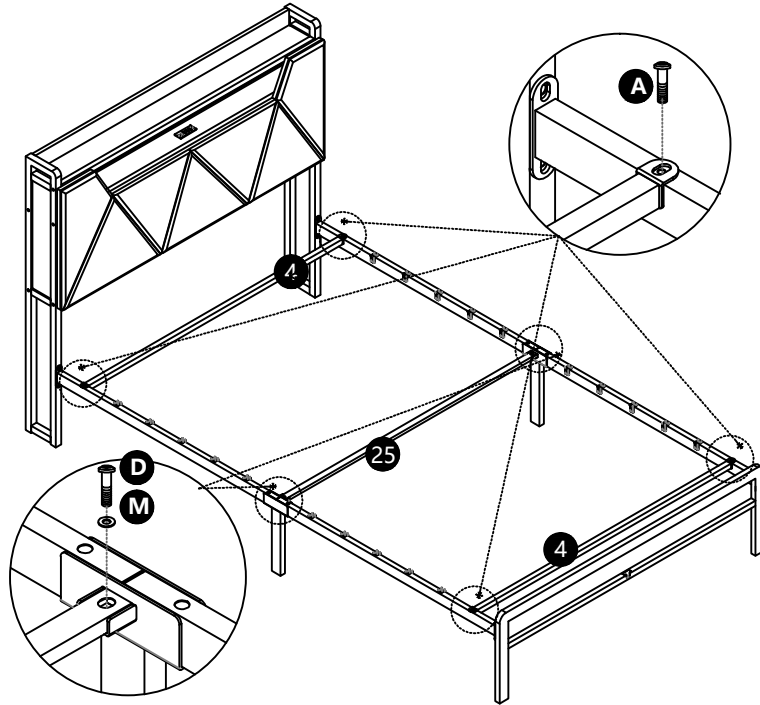

# 17

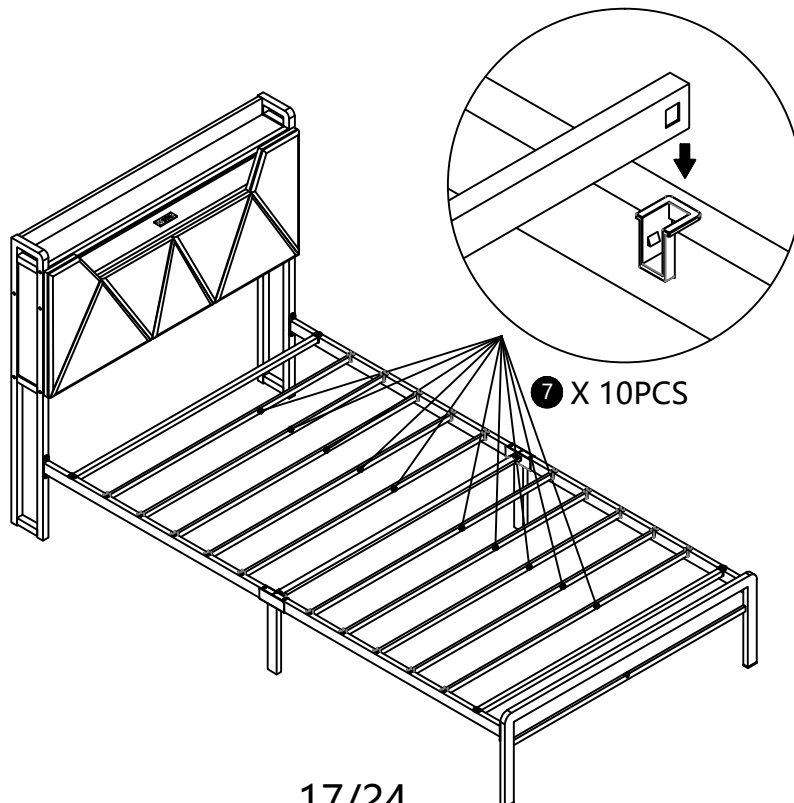

# 18

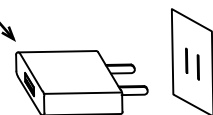
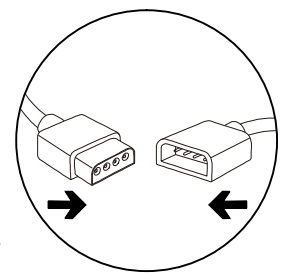
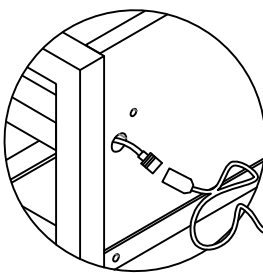
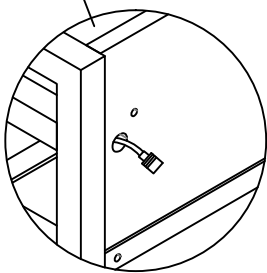
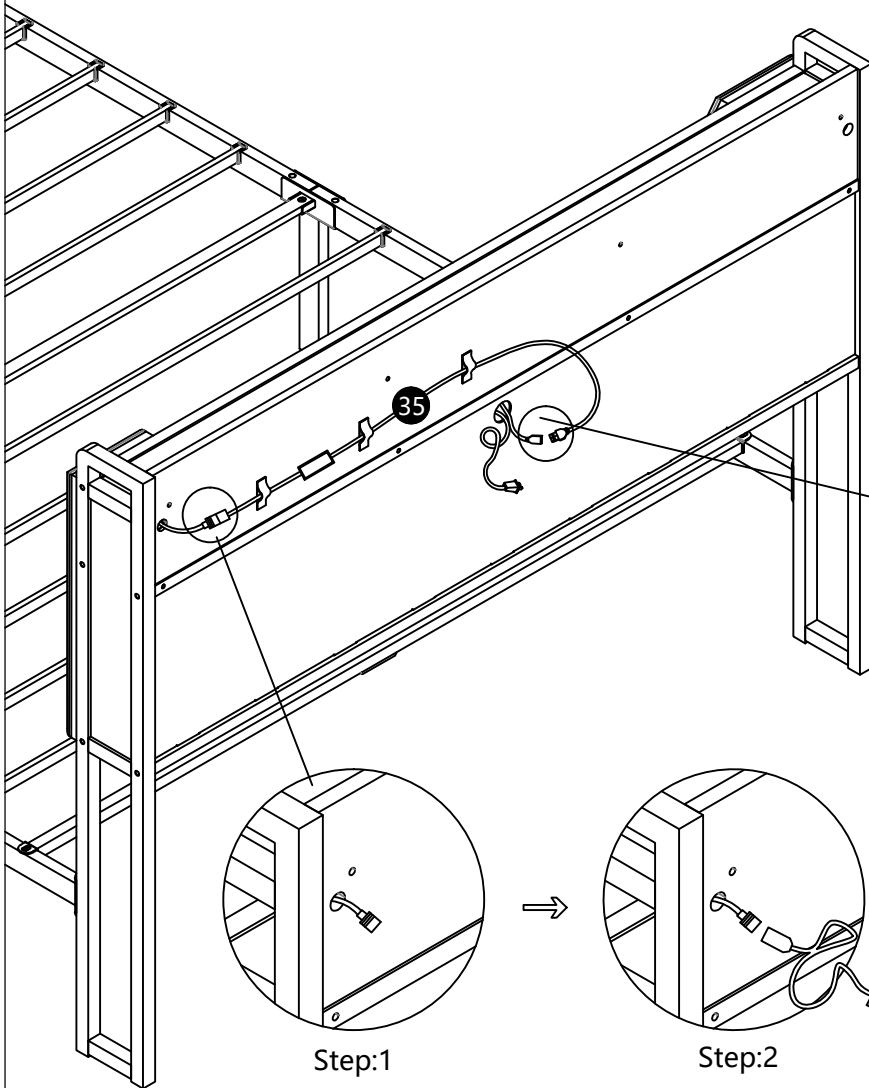
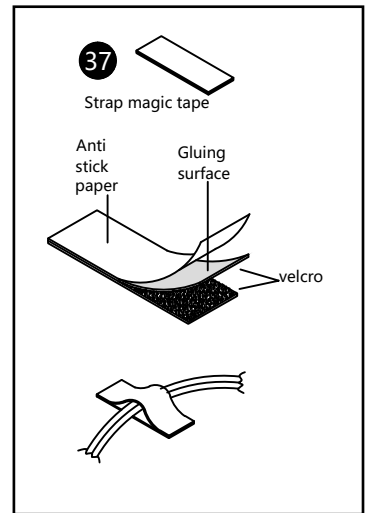

Plug not included  
Ohne Stecker  
Prise non incluse  
Spina non inclusa  
No incluye enchufes

# 19

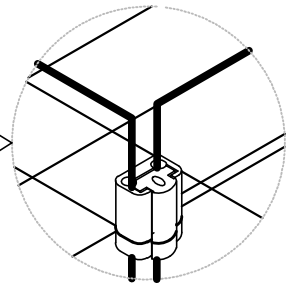
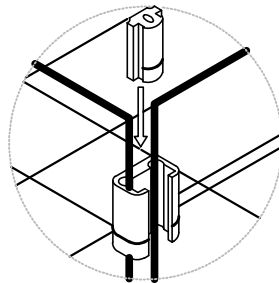
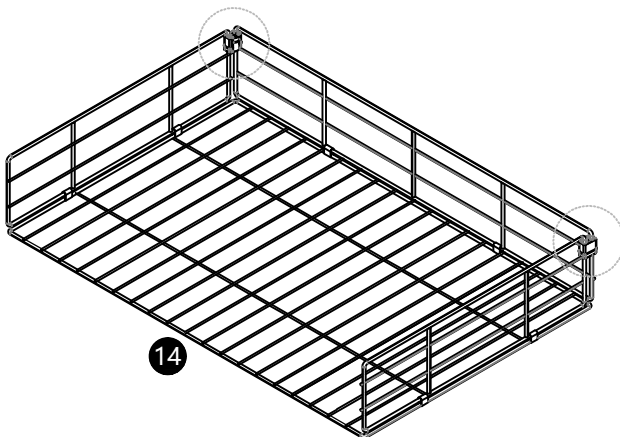
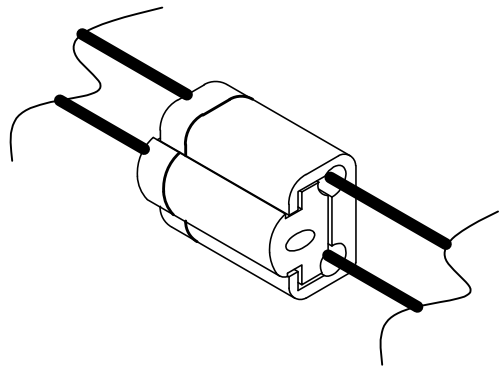
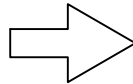
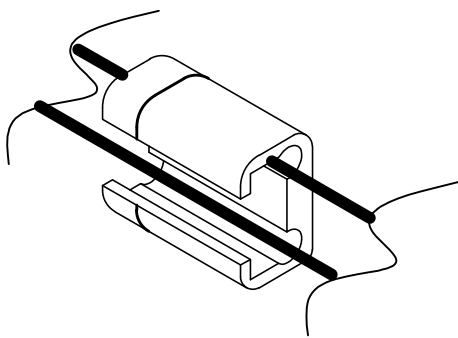
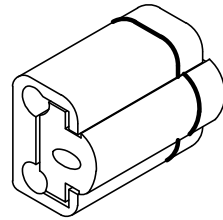
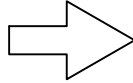
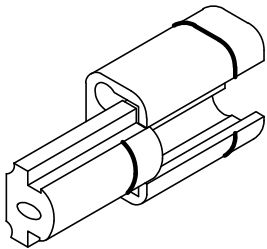
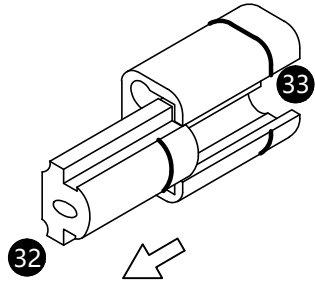
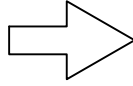
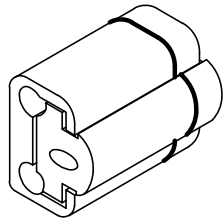

# 20

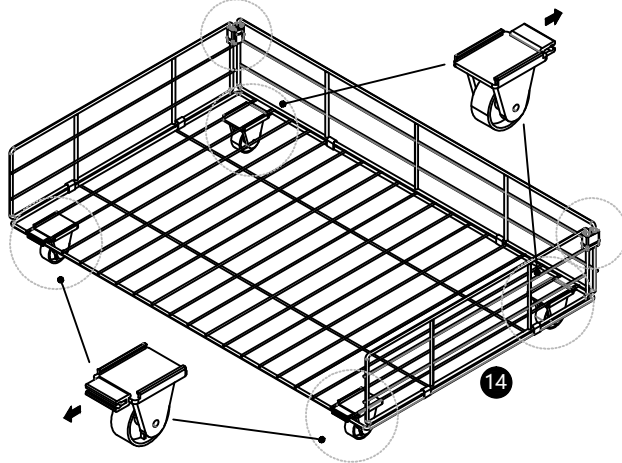
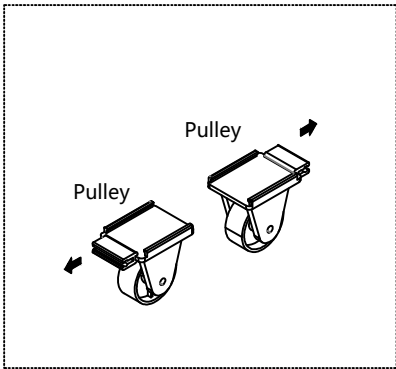
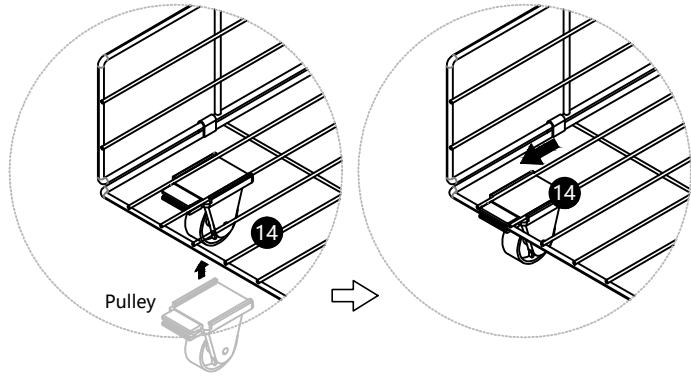

# 21

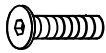

CX 4pcs

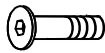

RX 1pcs

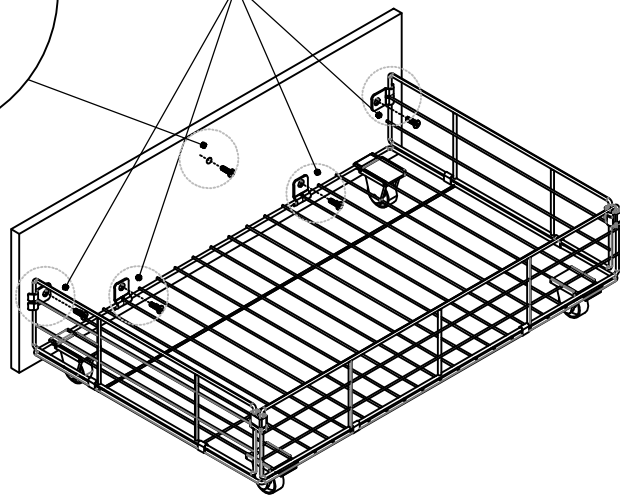
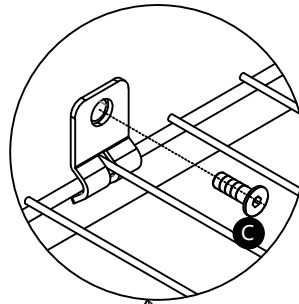
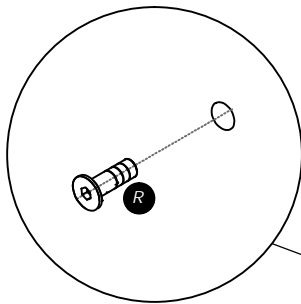

# 22

Lift the panel to allow the "R" to match the hole to secure the drawers. Same way for pulling out.

Heben Sie die Platte an, damit das "R" in das Loch passt, um die Schubladen zu sichern. Dasselbe gilt für das Herausziehen.

Soulevez le panneau pour permettre au "R" de s'aligner avec le trou pour sécuriser les tiroirs. Même procédé pour les retirer.

Sollevarre il pannello per consentire alla " R " di abbinare il foro per fissare i cassetti. Stesso modo per tirarsi fuori.

Levante el panel para que la "R" coincida con el agujero que fija el cajón. Lo mismo ocurre con la salida.

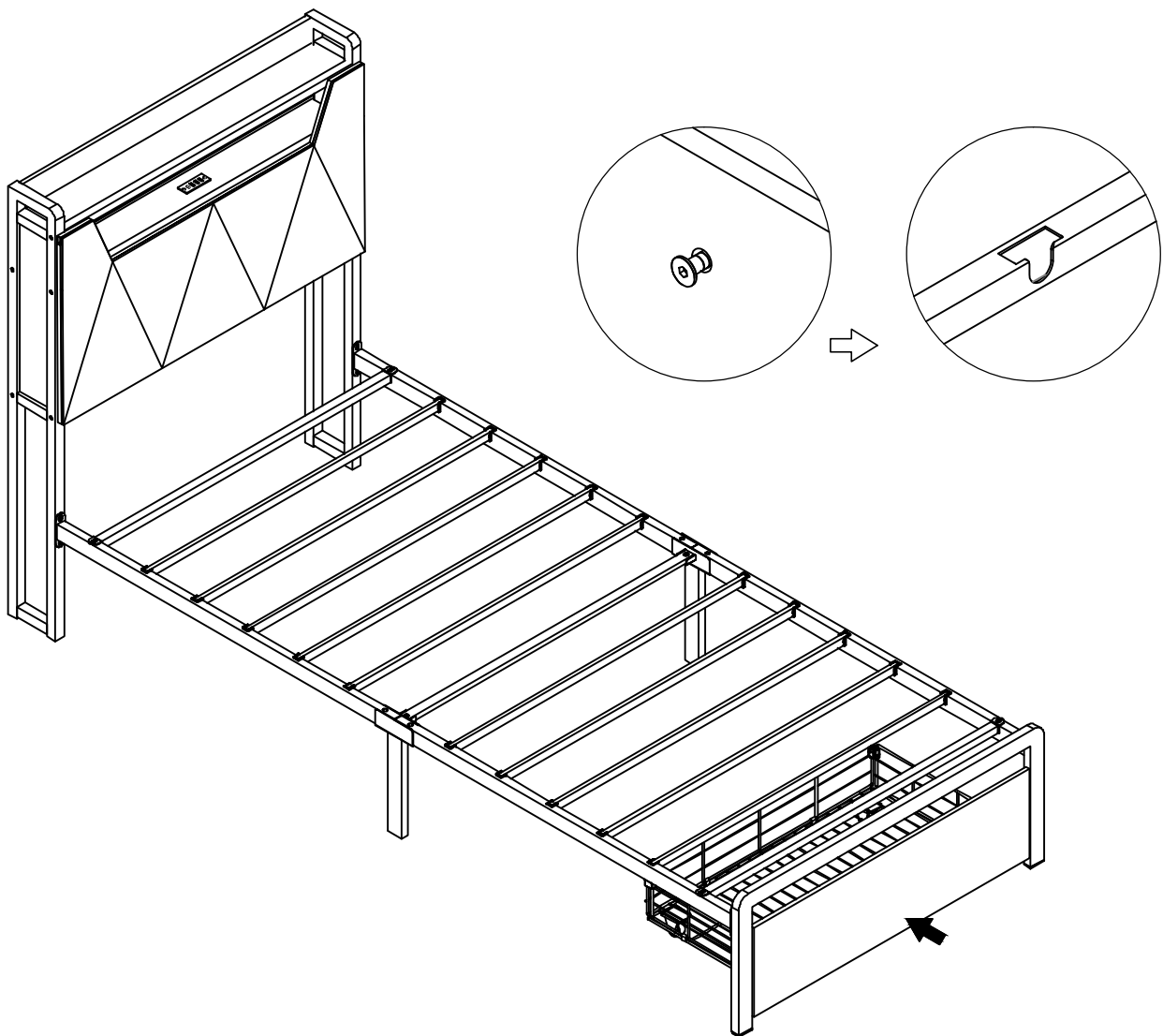



KeySense Testing & Certification International Co., Ltd.  
 1-3F, Lab Building, No.29 District, Zhongkai Hi-Tech  
 Industrial Development Park, Huizhou, Guangdong,  
 China

Tel:0752-3219929  
 Fax:0752-3219929  
<http://www.kst-cert.com>

# Technical Compliance Statement

Certificate No.: KST240304L008Q01

Report No.: KST240304L008Q01

The following product has been tested by us with the listed standards and found in Compliance with the council LVD directive 2014/35/EU. It is demonstrative for the Compliance with this LVD Directive.

**Holder:** DONGGUAN BAIYOU ELECTRONIC CO LTD  
**Address:** 2F A Building, Wufeng Industrial, Jintan Road, Danwu Shijie Town, Dongguan, Guangdong  
**Product:** USB CHARGER  
**Model Name:** BY213-TD04-C  
**Trade Name:** N/A

Test Standard	
EN 62368-1:2014+A11:2017	Audio/video, information and communication technology equipment Part 1: safety requirements



Signature:

Name:

Position:

Date:

Tony &u

General Manager

Apr. 26, 2024



The statement is based on single evaluation of one sample of above mentioned product. It does not imply an assessment of the whole production and does not permit the use of the test lab. Logo.

**GB** – NOTE: The battery in the remote control requires you to purchase and install it yourself.  
Model: CR2025 3.V

**DE** – HINWEIS: Die Batterie in der Fernbedienung müssen Sie selbst kaufen und installieren  
Modell: CR2025 3.V

**FR** – REMARQUE : la pile de la télécommande doit être achetée et installée par vos soins.  
Modèle : CR2025 3.V

**IT** – NOTA: la batteria del telecomando deve essere acquistata e installata autonomamente.  
Modello: CR2025 3.V

**ES** – NOTA: La pila del mando a distancia debe comprarla e instalarla usted mismo  
Modelo CR2025 3.V

①



②



③



④



⑤



⑥



⑦



⑧





## Verification of Compliance

**Verification No.:** MK23020083-P01C01

**Name and address of Applicant:** **Shenzhen Hongzhengyu Technology Co., LTD**  
Shenzhen baoan district rock street industrial science and technology industrial park of 2 Hai'an lanyu 3 5 floor of A

**Name and address of Manufacturer:** **Shenzhen Hongzhengyu Technology Co., LTD**  
Shenzhen baoan district rock street industrial science and technology industrial park of 2 Hai'an lanyu 3 5 floor of A

**Product name:** **Lamp strip**  
HZY-2835-120D-12V, HZY-2835-30D-5V, HZY-2835-60D-5V, HZY-2835-120D-5V, HZY-2835-60D-12V, HZY-2835-60D-24V, HZY-2835-120D-24V, HZY-2835RGB-60D-5V, HZY-2835RGB-60D-12V, HZY-5050-30D-5V, HZY-5050-60D-5V, HZY-5050-30D-12V, HZY-5050-60D-12V, HZY-5050-60D-24V, HZY-5050RGB-30D-5V, HZY-5050RGB-60D-5V, HZY-5050RGB-30D-12V, HZY-5050RGB-60D-12V, HZY-5050RGB-60D-24V

**Product model(s):**

**Product trademark:** N/A

This verification confirms that the product meets the requirements of the following standard.  
The conformity was demonstrated based on following standard(s) listed by European Commission as harmonized with Directive RoHS 2.0 Directive (EU) 2015/863 and (EU)2017/2102 amending Annex II to Directive 2011/65/EU

IEC 62321-1:2013	IEC 62321-3-1:2013
IEC 62321-4:2013/AMD1:2017	IEC 62321-5:2013
IEC 62321:6-2015	IEC 62321-7-1:2015
IEC 62321-7-2:2017	IEC 62321-8:2017

*The verification has been carried out in accordance with individual rules and conditions agreed with the applicant. Evaluation has been carried out in accordance with:*

**Test report(s) No.:** MK23020083-P01C01  
**Test conducted by:** TMC Testing Services (Shenzhen) Co., Ltd.  
**Verification issue date:** February 25, 2023

**Notes:**

*This verification refers to the above mentioned product and its conformity in regards of above mentioned standard(s) was proven on test sample.*

*This verification does not imply meeting all essential requirements, assessment of the series-production or any other restricted Notified Bodies conformity assessment procedure appropriate for the product.*

*This verification holder shall use this verification in connection to verification of conformity and technical data relevant for the product the verification was issued.*

**TMC Testing Services (Shenzhen) Co., Ltd.**

t:86-755-86642861 cert@tmc-lab.com www.tmc-lab.com

1st Floor, Block A1, Zone A, Xinshidai Gongrong Industrial Park, No. 2, Shihuan Road, Shiyuan Street, Baoan District, Shenzhen, China



TMC