

**D** Gebrauchsanweisung

**NL** Gebruiksrichtlijnen

**IT** Istruzioni per l'uso

**CZ** Pokyny k použití

**HU** Használati útmutató

**PT** Instruções de utilização

**SK** Pokyny k použitiu

**GB** Instructions for use

**FR** Instructions d'utilisation

**PL** Instrukcja obsługi

**ES** Instrucciones de empleo

**RO** Instrucțiuni de folosire

**RU** Инструкция по монтажу

**TR** Kullanım talimatları

WF304491AAA

## English

### IMPORTANT ! KEEP FOR FUTURE REFERENCE : READ CAREFULLY

- To be assembled by an adult. Assembly must be checked by an adult before use
- WARNING ! Keep all screws, small parts and plastic bags out of the reach of children
- Properly identify all parts before assembling
- Never use your item if any of its parts are broken or missing
- Should any problems arise, please contact our After Sales Service
- Manufacturer's instructions shall be followed at all times
- Care: Clean with a soft, dry cloth. In case of larger stains, carefully rub with a slightly damp, non-abrasive sponge
- Avoid the risk of fire by not placing furniture near sources of ignition or hot items
- Do not jump on the bed

## Deutsch

### WICHTIG ! ZUM SPÄTEREN NACHSCHLAGEN AUFBEWAHREN: SORGFÄLTIG LESEN

- Muss von einem Erwachsenen zusammengebaut werden. Der Zusammenbau muss vor dem Gebrauch von einem Erwachsenen überprüft werden
- WARNUNG! Bewahren Sie alle Schrauben, Kleinteile und Plastikbeutel außerhalb der Reichweite von Kindern auf
- Kennzeichnen Sie vor dem Zusammenbau alle Teile richtig
- Benutzen Sie Ihren Artikel niemals, wenn Teile gebrochen sind oder fehlen
- Sollten Probleme auftreten, wenden Sie sich bitte an unseren Kundendienst
- Die Anweisungen des Herstellers sind stets zu befolgen
- Pflege: Mit einem weichen, trockenen Tuch reinigen. Bei größeren Flecken vorsichtig mit einem leicht feuchten, nicht scheuernden Schwamm abreiben. nicht scheuernden Schwamm
- Vermeiden Sie die Gefahr eines Brandes, indem Sie die Möbel nicht in der Nähe von Zündquellen oder heißen Gegenständen aufstellen
- Nicht auf das Bett springen

## Français

### IMPORTANT ! CONSERVER POUR RÉFÉRENCE ULTÉRIEURE : LIRE ATTENTIVEMENT

- Le montage doit être effectué par un adulte. Le montage doit être vérifié par un adulte avant Utilisation
- ATTENTION ! Tenir les vis, les petites pièces et les sachets en plastique hors de portée des enfants
- Identifiez correctement toutes les pièces avant de les assembler
- N'utilisez jamais votre article si l'une de ses pièces est cassée ou manquante
- En cas de problème, veuillez contacter notre service après-vente
- Les instructions du fabricant doivent être respectées à tout moment
- Entretien : nettoyer avec un chiffon doux et sec. En cas de taches plus importantes, frotter soigneusement avec une éponge non abrasive légèrement humide. légèrement humide et non Abrasive
- Évitez les risques d'incendie en ne plaçant pas les meubles à proximité de sources d'inflammation ou d'objets chauds
- Ne pas sauter sur le lit

## Italiano

### IMPORTANTE! CONSERVARE PER RIFERIMENTO FUTURO: LEGGERE ATTENTAMENTE

- Deve essere assemblato da un adulto. L'assemblaggio deve essere controllato da un adulto prima dell'uso
- **ATTENZIONE!** Tenere tutte le viti, le piccole parti e i sacchetti di plastica fuori dalla portata dei bambini
- Identificare correttamente tutte le parti prima dell'assemblaggio
- Non utilizzare mai l'articolo se alcune parti sono rotte o mancanti
- In caso di problemi, si prega di contattare il nostro Servizio Post Vendita
- Le istruzioni del produttore devono essere sempre seguite
- Cura: Pulire con un panno morbido e asciutto. In caso di macchie più estese, strofinare accuratamente con una spugna leggermente umida e nonspugna leggermente umida e non abrasiva
- Evitare il rischio di incendio, non collocando i mobili vicino a fonti di accensione o a oggetti caldi
- Non saltare sul letto

## Español

### ¡ IMPORTANTE ! CONSERVELO PARA FUTURAS CONSULTAS: LEA ATENTAMENTE

- Debe ser montado por un adulto. El montaje debe ser comprobado por un adulto antes del uso
- ADVERTENCIA Mantenga todos los tornillos, piezas pequeñas y bolsas de plástico fuera del alcance de los niños.
- Identifique correctamente todas las piezas antes de montarlas
  - Nunca utilice su artículo si alguna de sus piezas está rota o falta
  - Si surge algún problema, póngase en contacto con nuestro Servicio Postventa
  - Las instrucciones del fabricante deben seguirse en todo momento
  - Cuidado: Limpiar con un paño suave y seco. En caso de manchas más grandes, frote cuidadosamente con una esponja no abrasiva ligeramente humedecida.
  - Evite el riesgo de incendio no colocando los muebles cerca de fuentes de ignición u objetos calientes.
  - No saltar sobre la cama.

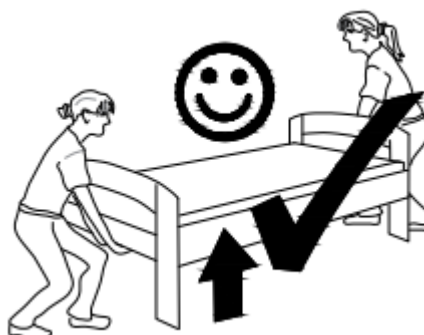
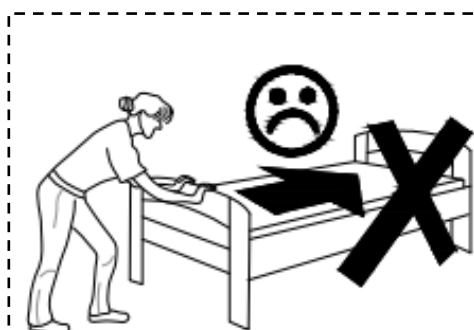



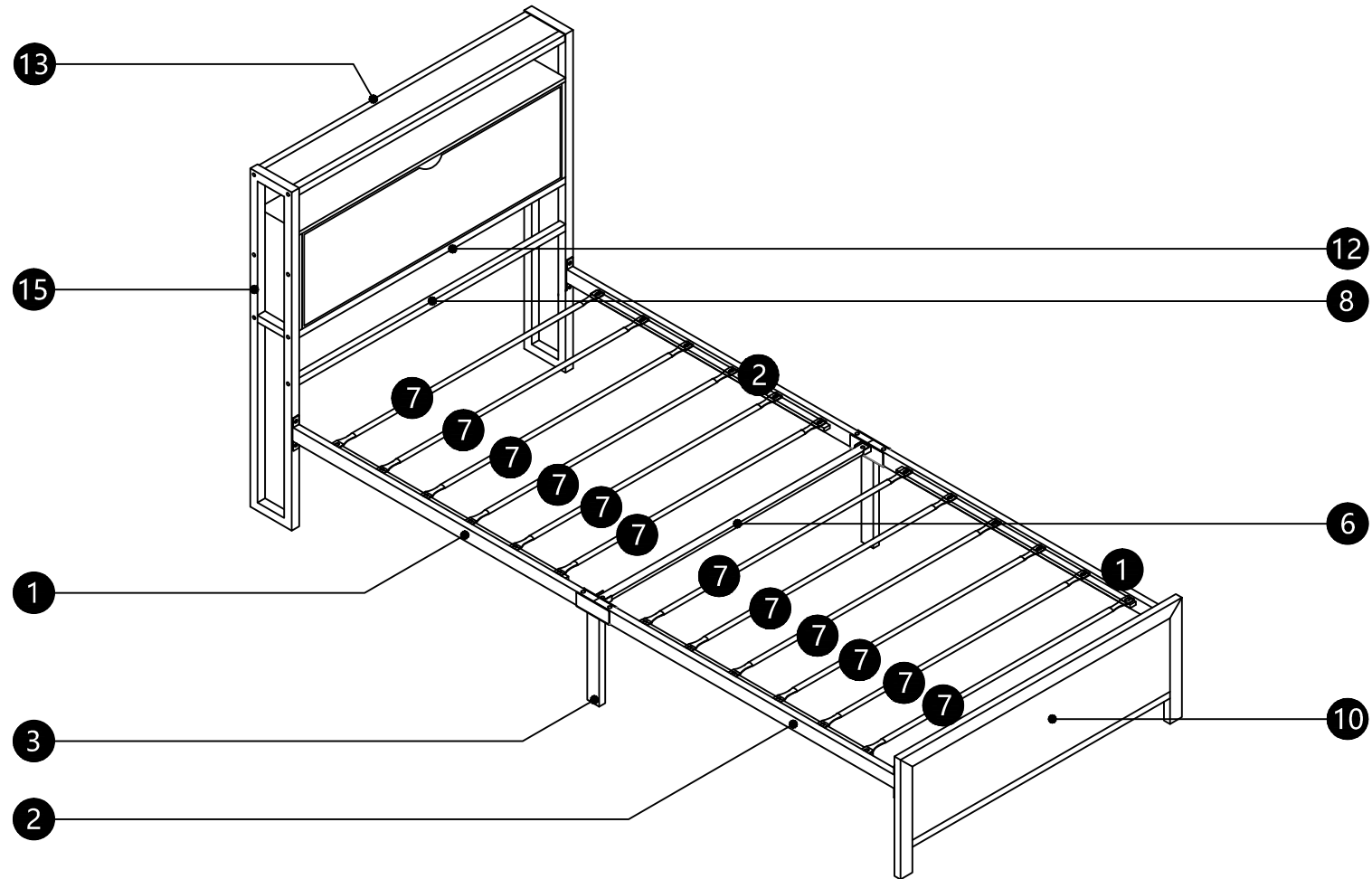





# Montageanleitung für Bettgestell

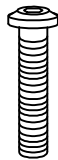
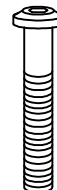
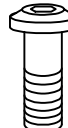
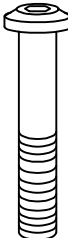
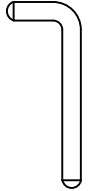
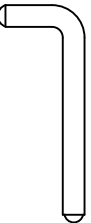
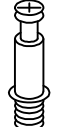

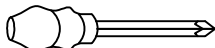
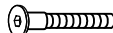

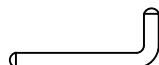
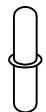
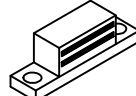
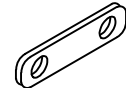
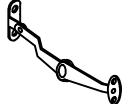

# Montageanleitung für Bettgestell

## Hardware Parts Hardware-Teile SKU: WF304491AAA

<b>A</b> x 3  M6*10	<b>B</b> x 24  M6*15	<b>C</b> x 4  M6*34	<b>D</b> x 10  M6*45	<b>E</b> x 10  M8*20	<b>F</b> x 4  M8*55	<b>H</b> x 1  M6
<b>I</b> x 1  M8	<b>J</b> x 4  M6*15	<b>K</b> x 4  M6*15	<b>L</b> x 1  M6*15	<b>M</b> x 4  M5*35	<b>N</b> x 9  M3*12	<b>O</b> x 1  M3
<b>P</b> x 2  M6*10	<b>Q</b> x 2  M6*15	<b>R</b> x 2  M6*15	<b>S</b> x 1  M6*15	<b>U</b> x 5  M3*16		

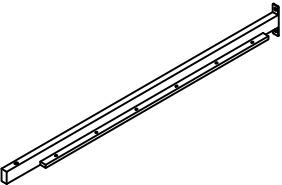
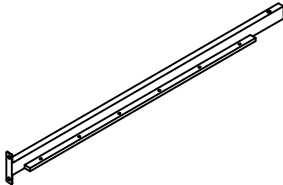
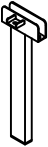
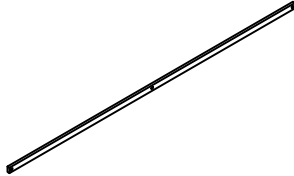
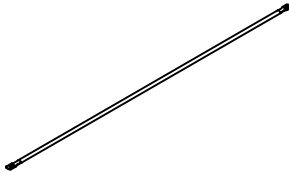
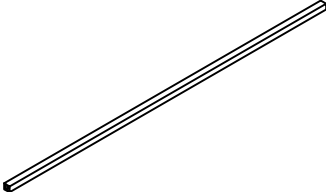
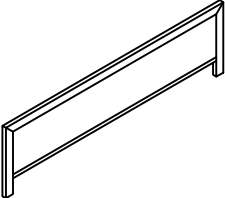
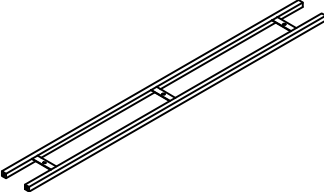
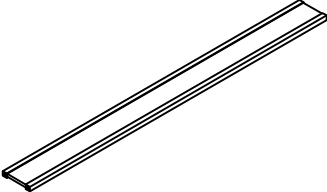
# Montageanleitung für Bettgestell

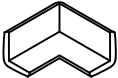
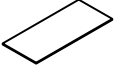
## Part List-Stückliste SKU: WF304491AAA

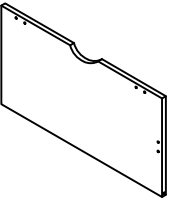
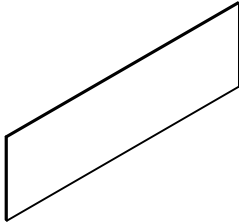
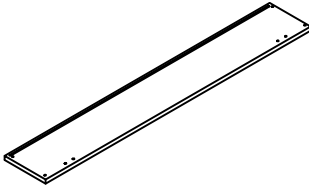
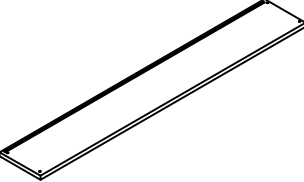
<b>1</b> x 2 	<b>2</b> x 2 	<b>3</b> x 2 	<b>6</b> x 1 	<b>7</b> x 12 	<b>8</b> x 1 
<b>10</b> x 1 	<b>12</b> x 1 	<b>13</b> x 1 	<b>15</b> x 2 	<b>16</b> x 2  Anti-Kollisions	<b>17</b> x 4  Doppelseitiges Klebeband
<b>19</b> x 1 	<b>20</b> x 1 	<b>24</b> x 1 	<b>26</b> x 1 	<b>27</b> x 1 	<b>28</b> x 1 

# Montageanleitung für Stauraum-Kopfteil

## Explosionszeichnung

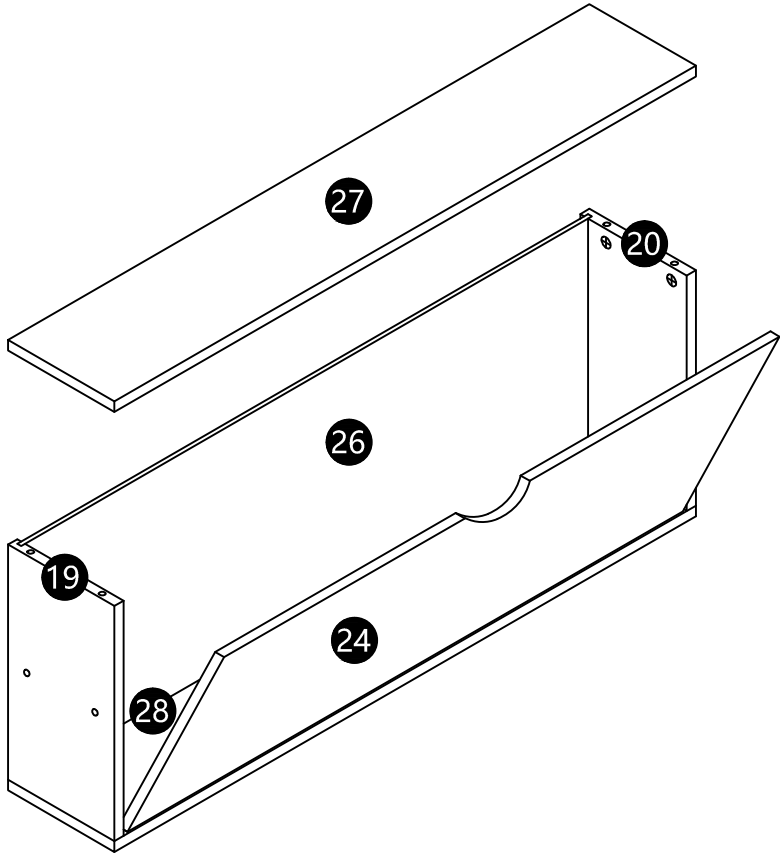

# Montageanleitung für Stauraum-Kopfteil

Schritt:1

 M3\*12 **N** X4PCS

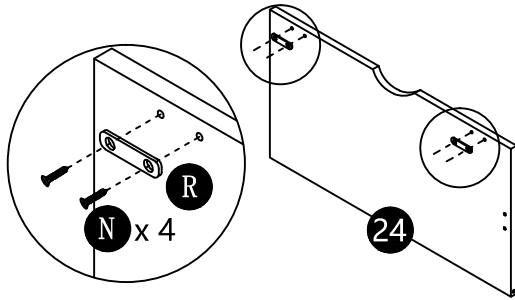

Schritt:2

 **P** X 2PCS

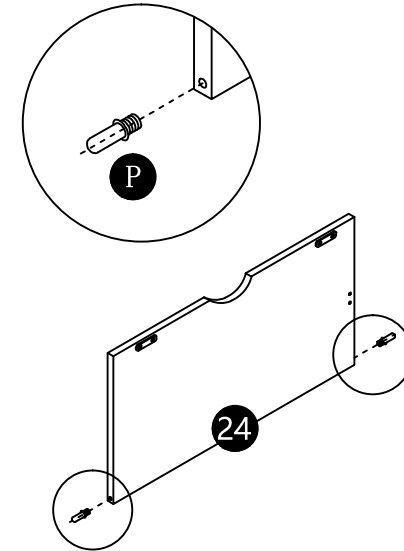

Schritt:3

 M3\*12 **N** X 2PCS

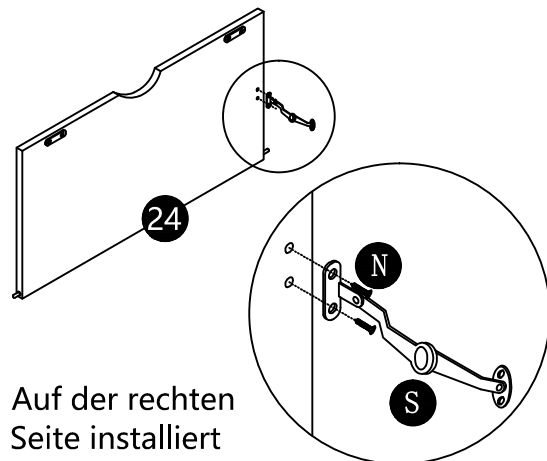

Schritt:4

 M5\*35 **M** X 2PCS

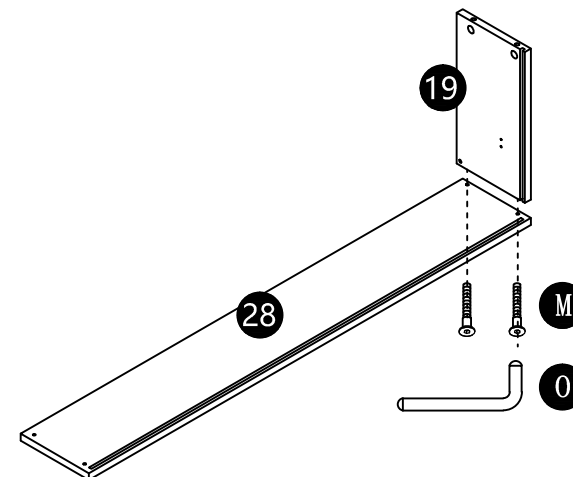

# Montageanleitung für Stauraum-Kopfteil

Schritt:5

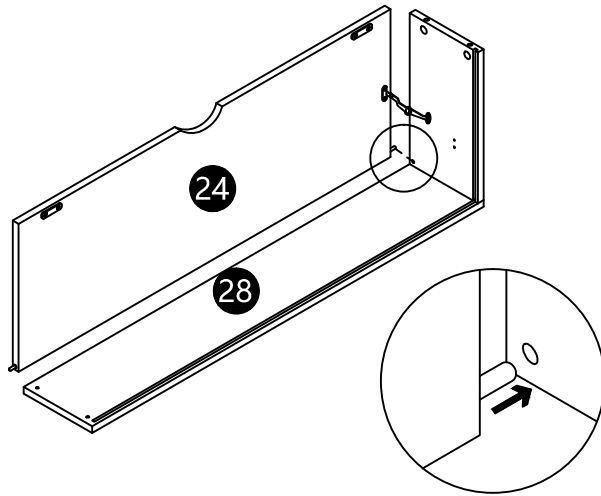

Schritt:6

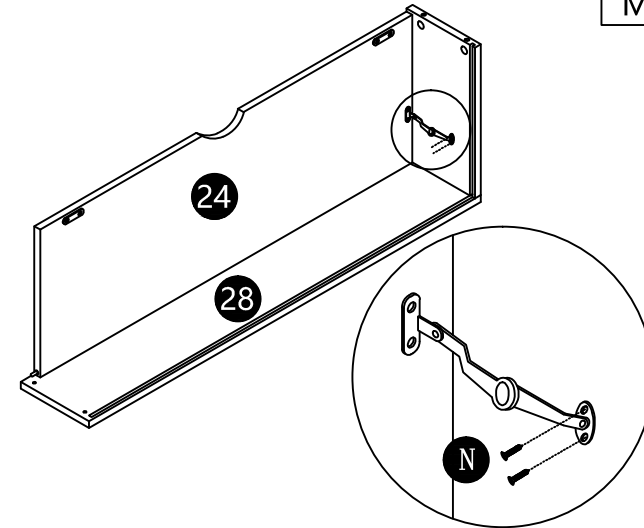

 **N** X 2PCS  
M3\*12

Schritt:7

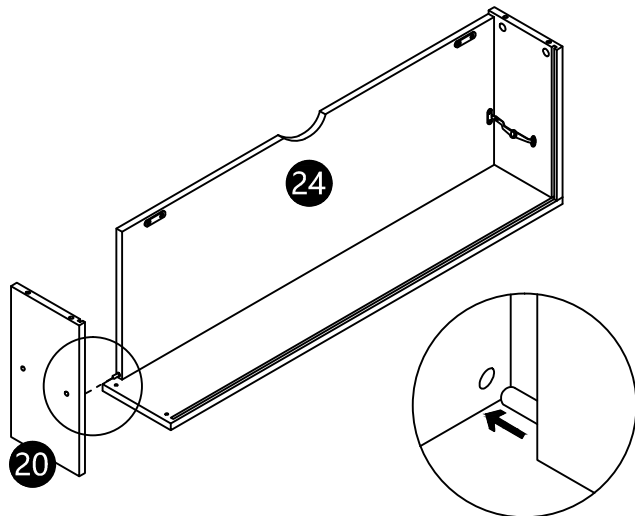

Schritt:8

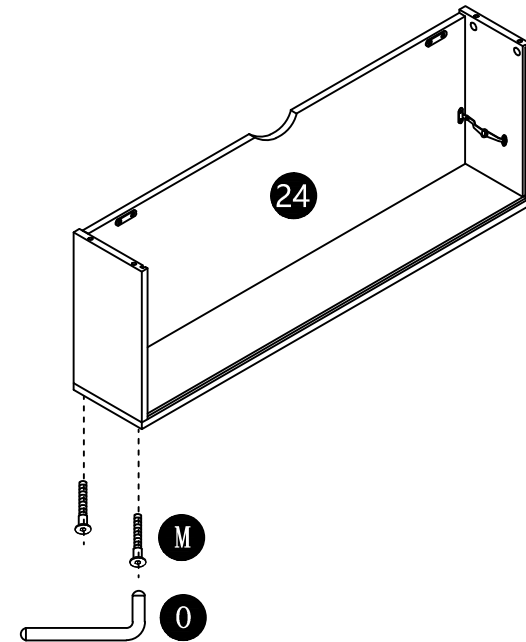

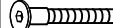
 **M** X 2PCS  
M5\*35

# Montageanleitung für Stauraum-Kopfteil

Schritt:9

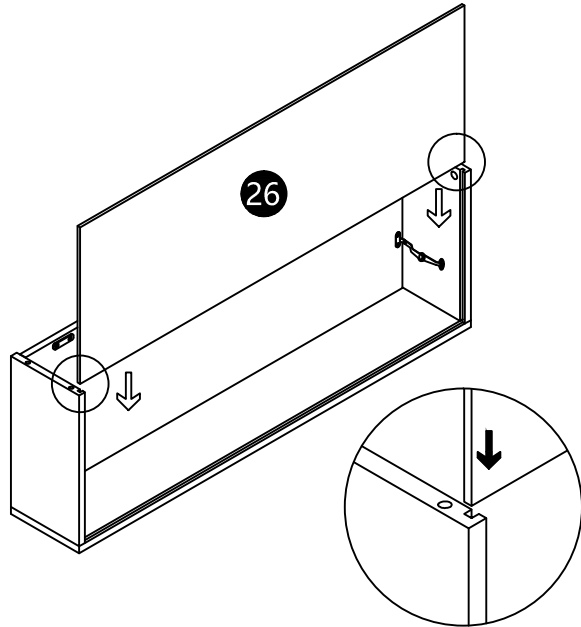

Schritt:10

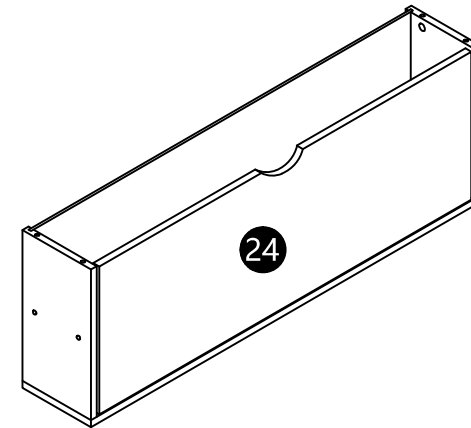

Schritt:11

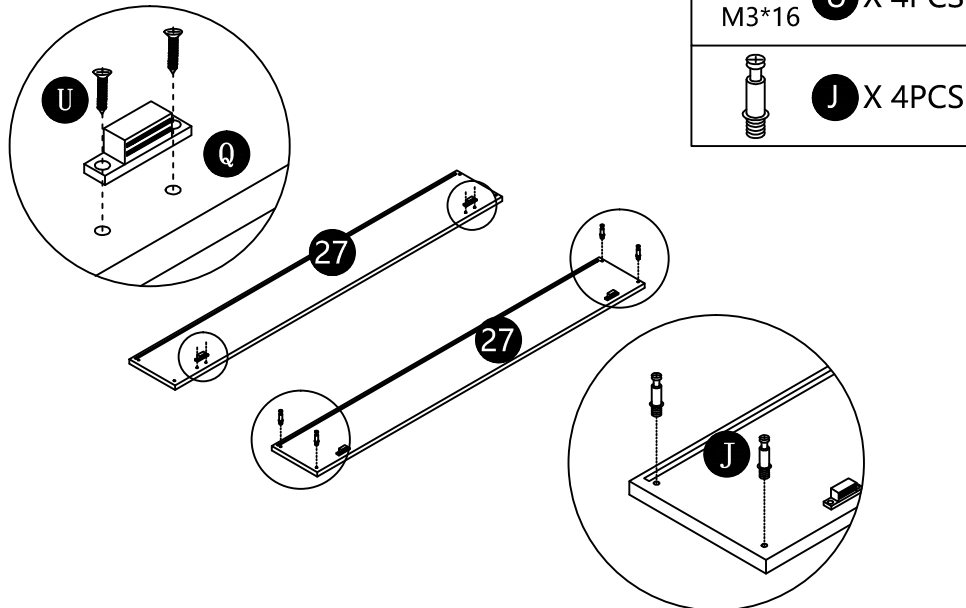

Schritt:12

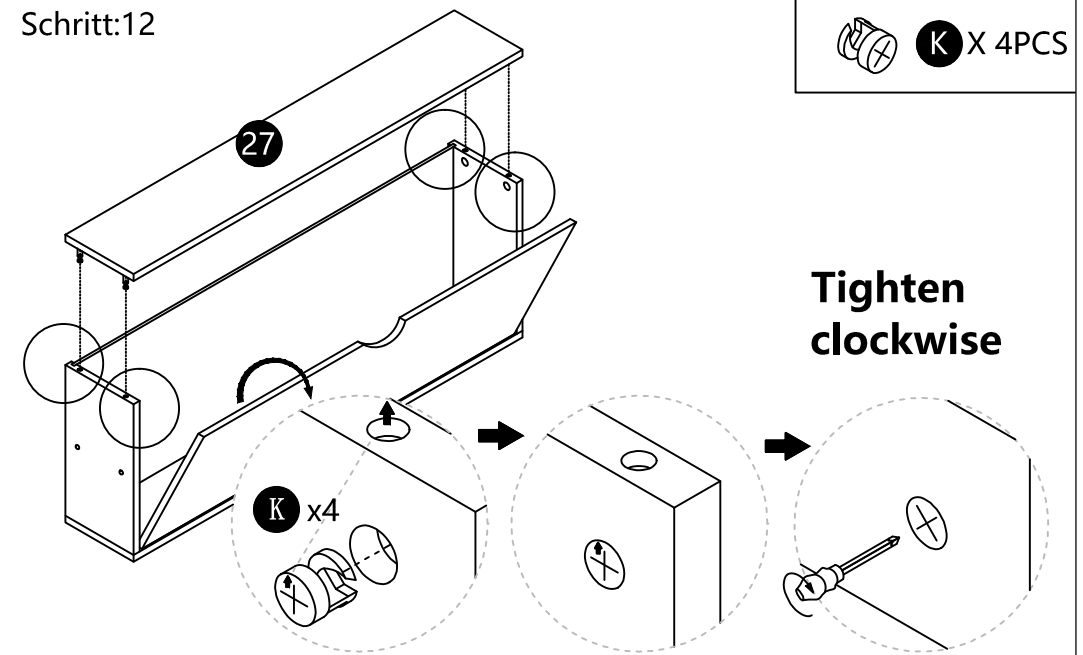

# Montageanleitung für Stauraum-Kopfteil

Schritt:1



**D** X 6PCS

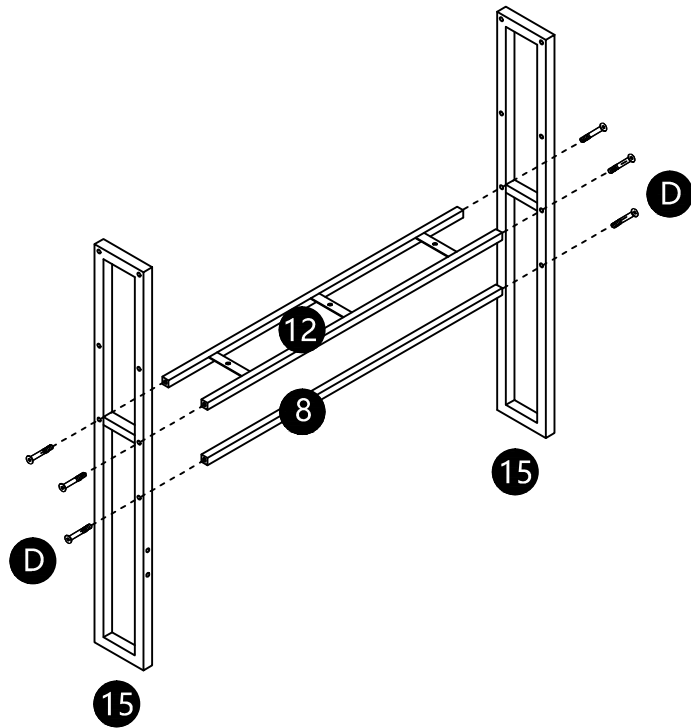

Schritt:2



**A** X 3PCS

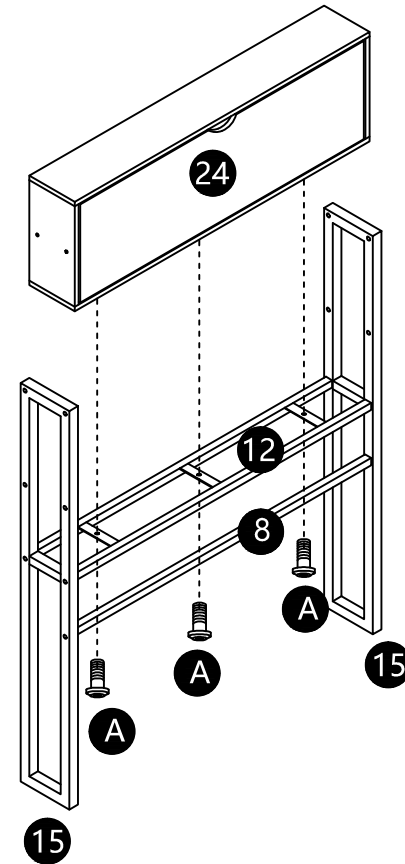

# Montageanleitung für Bettgestell

Schritt:3



**C** X 4PCS

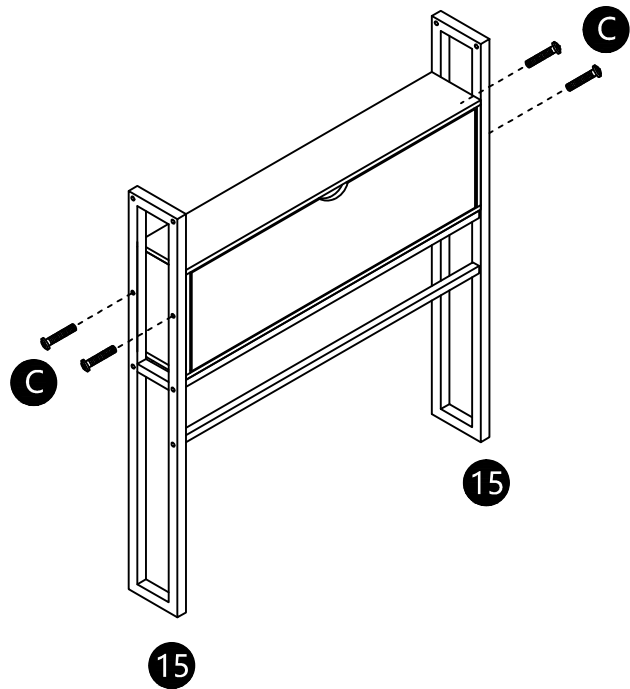

Schritt:4



**D** X 4PCS

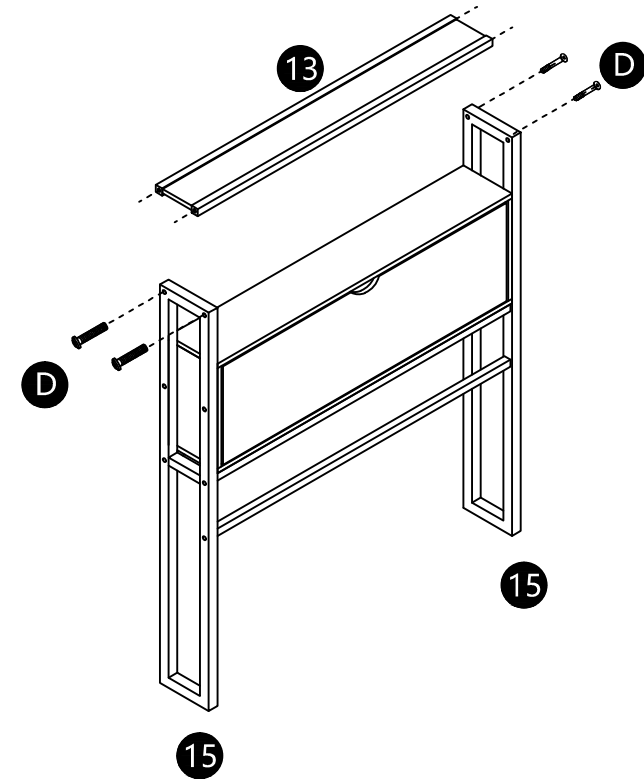

# Montageanleitung für Bettgestell

Schritt:5

 **F** X 4PCS  
M8\*55

**Achten Sie auf die Richtung**

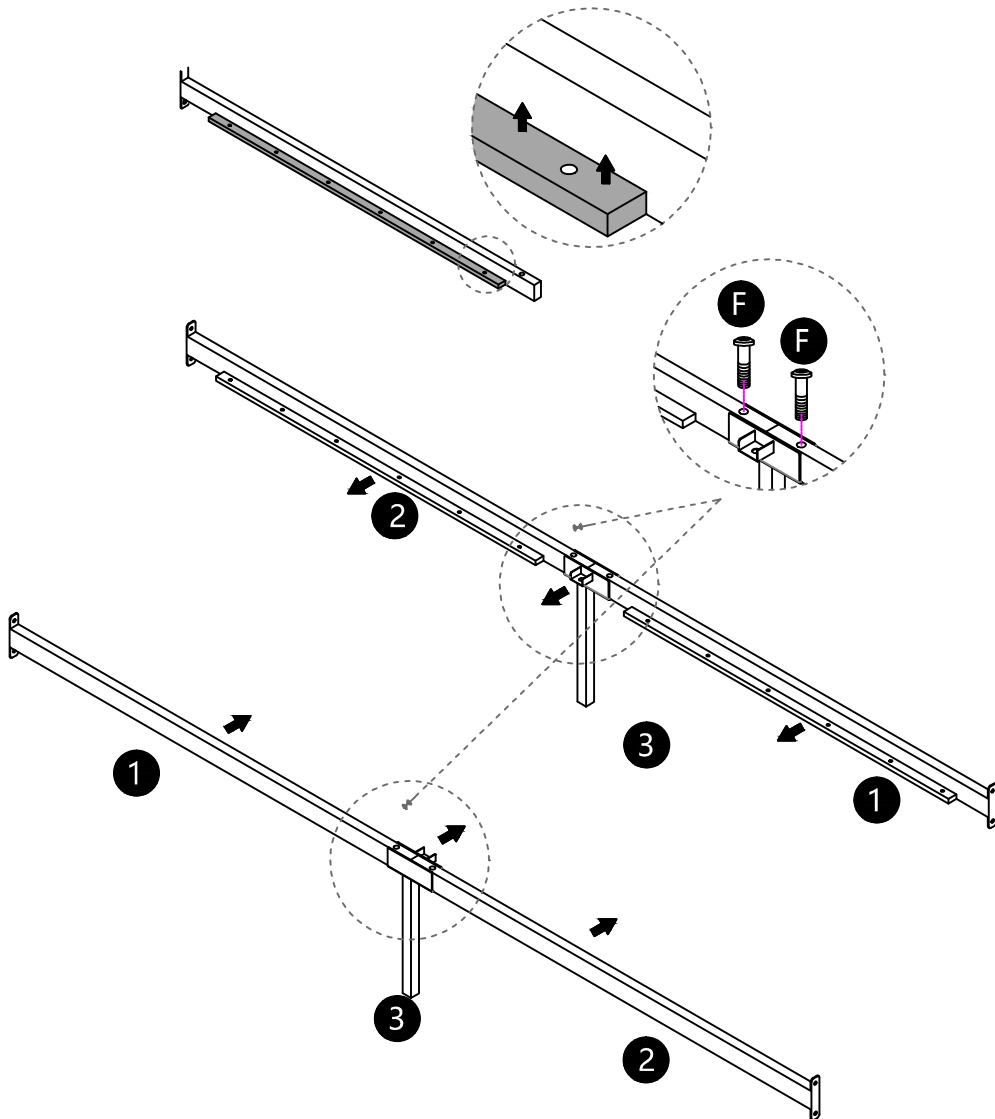

Schritt:6

 **E** X 8PCS  
M8\*20

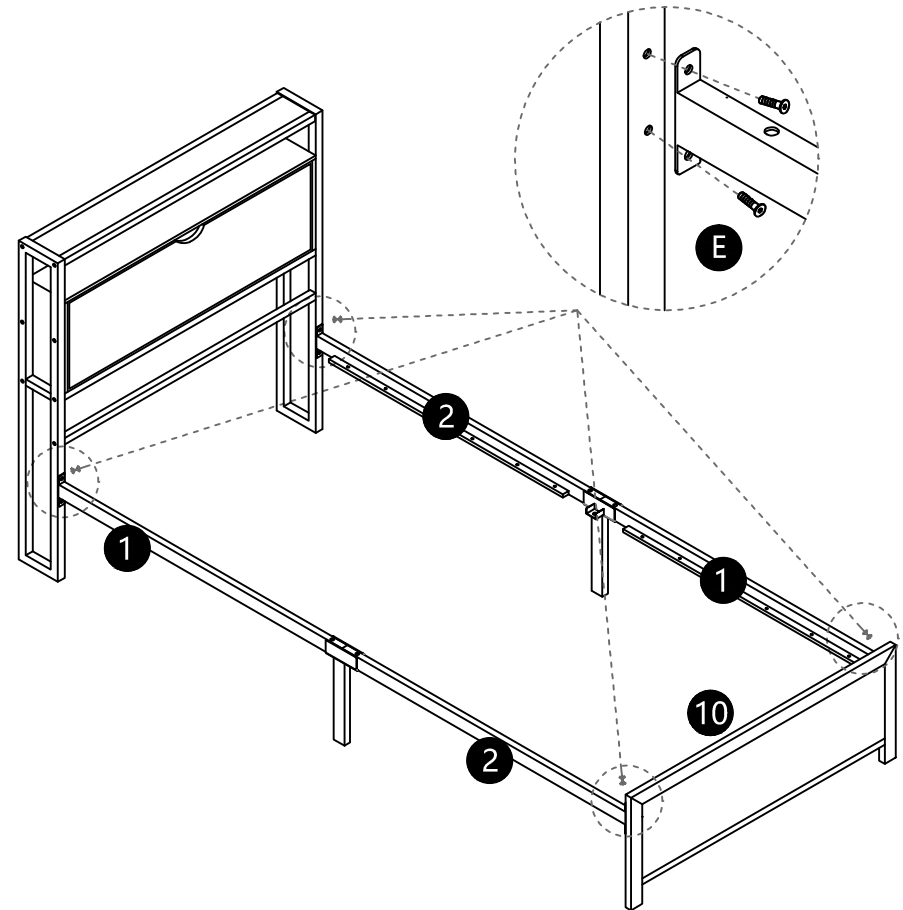

# Montageanleitung für Bettgestell

Schritt:7

 **E** X 2PCS  
M8\*20

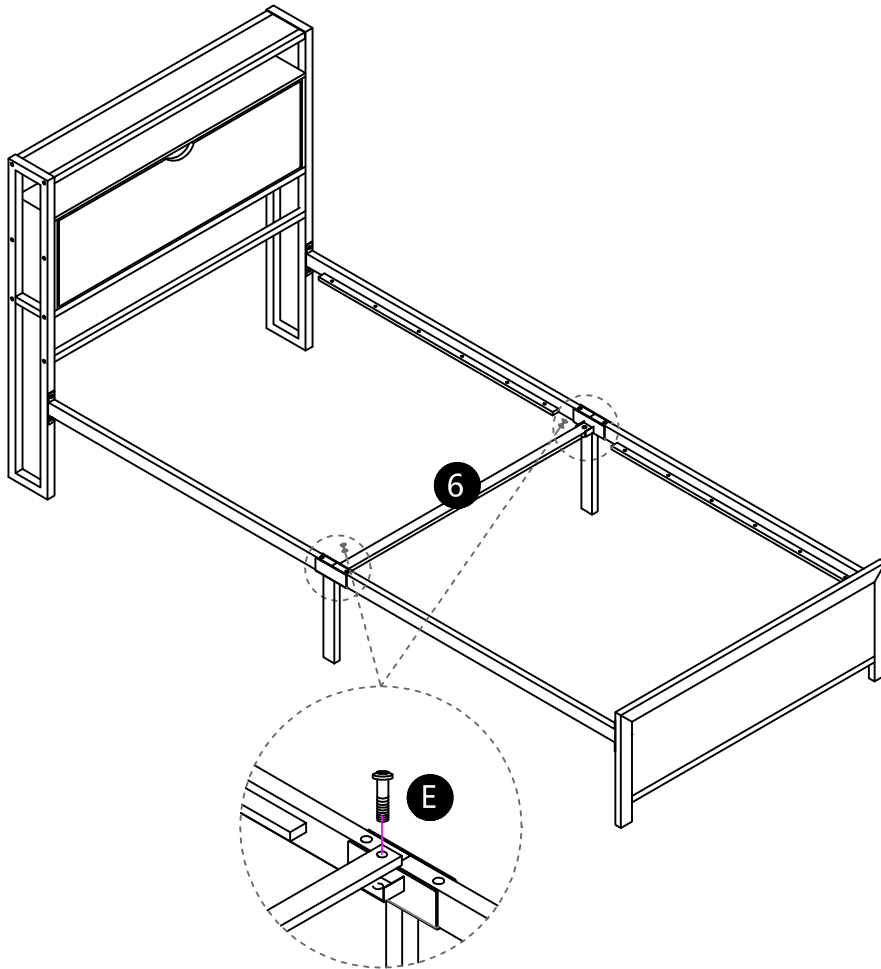

Schritt:8

 **B** X 24PCS  
M6\*15

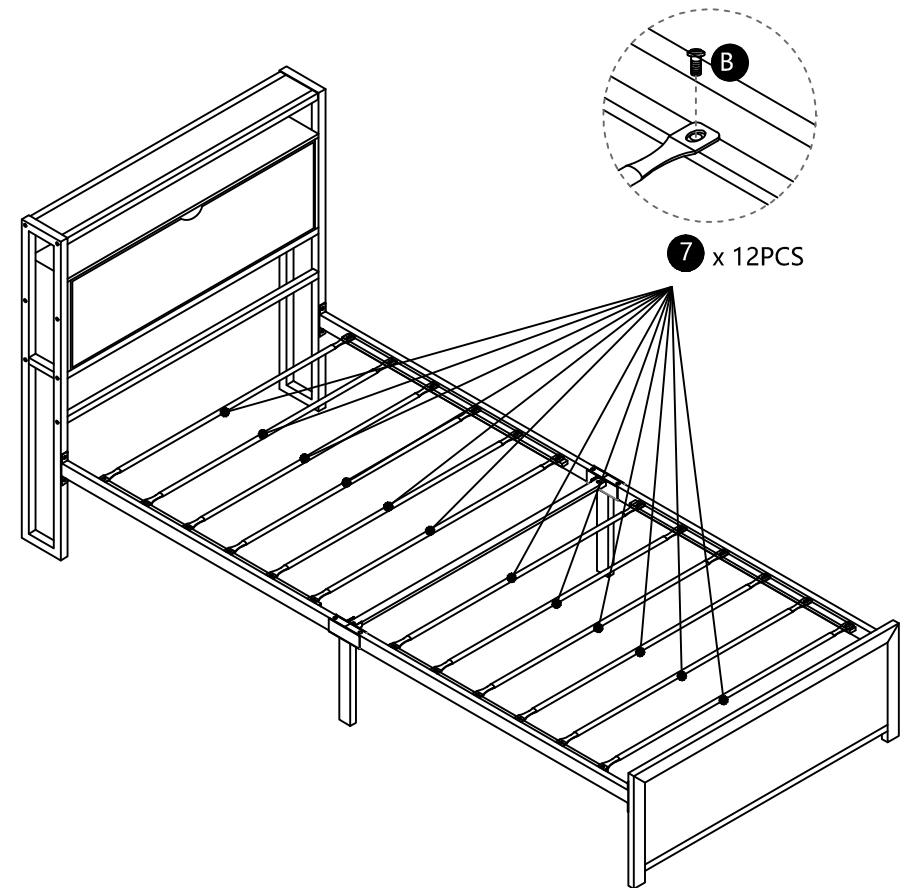

# Montageanleitung für Bettgestell

Es gibt eine kleine Versiegelungstasche in der Verpackung.  
In der Versiegelungstasche befinden sich zwei Stück  
doppelseitiges Klebeband und zwei Crash-Pads.  
Wie in der Abbildung unten gezeigt.

