

N634P362416W

N634P362417W

Product manual
Gebrauchsanweisung
Manuel du produit
Manual del producto
Manuale del prodotto

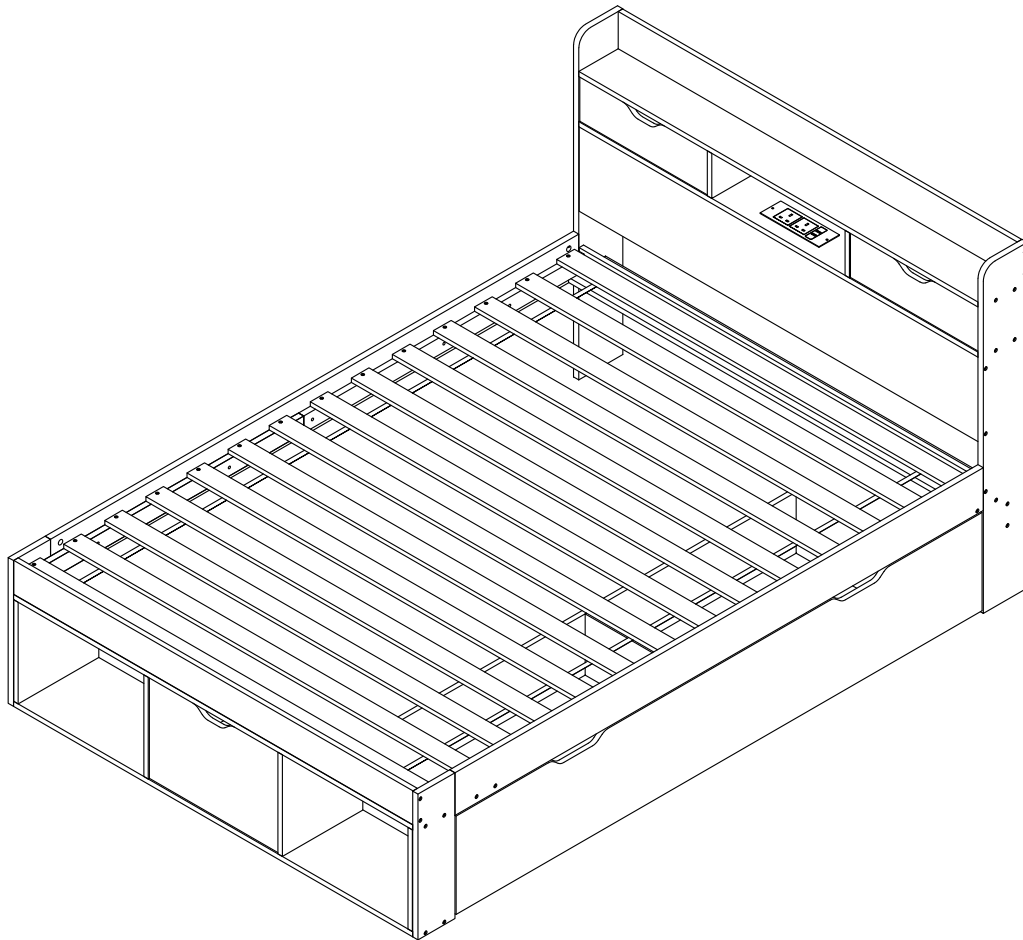

EN:Our product will be delivered to you in 2 packages.

The delivery times of these 2 packages may differ, please be patient and thank you for your understanding

FR:Notre produit vous sera livré en 2 colis. Les délais de livraison de ces 2 colis peuvent différer, soyez patient et merci de votre compréhension

DE:Unser Produkt wird Ihnen in 2 Paketen geliefert.

Die Lieferzeiten dieser 2 Pakete können unterschiedlich sein. Bitte haben Sie Geduld und vielen Dank für Ihr Verständnis.

IT:Il nostro prodotto ti verrà consegnato in 2 pacchi. I tempi di consegna di questi 2 pacchi potrebbero variare , ti preghiamo di essere paziente e grazie per la comprensione.

ES:Nuestro producto le será entregado en 2 paquetes. Los tiempos de entrega de estos 2 paquetes pueden diferir , tenga paciencia y gracias por su comprensión.

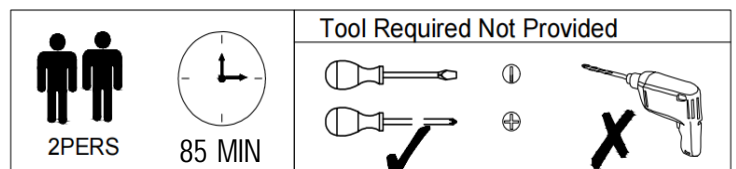



[DE]

Warnung: Lesen Sie die Anleitung vor dem Zusammenbau bitte vollständig durch. Überprüfen Sie, ob Sie alle auf den Seiten aufgeführten Komponenten und Werkzeuge haben.

Warnung: Legen Sie alle Teile auf eine ebene Fläche. Legen Sie eine weiche Decke oder Ähnliches darunter, um sie vor Kratzern oder Flecken zu schützen. Vermeiden Sie es, Komponenten über den Boden zu ziehen oder zu schieben.

Warnung: Überprüfen Sie regelmäßig alle Beschläge und Befestigungen, um sicherzustellen, dass sie sicher sind und um Unfälle zu vermeiden. Wenn Teile fehlen, kaputt, beschädigt oder abgenutzt sind, verwenden Sie das Produkt nicht weiter, bis es mit vom Hersteller autorisierten Teilen repariert wurde.

Warnung: Lassen Sie Kinder nicht auf die Möbel klettern, da dies zum Umkippen und zu schweren Verletzungen führen kann. Bauen Sie die Möbel außerhalb der Reichweite von Kindern zusammen.

Warnung: Stellen Sie die Möbel nicht in die Nähe von Feuerquellen oder heißen Gegenständen, um Brandgefahr zu vermeiden.

Warnung: Reinigen Sie die Möbel mit einem feuchten Tuch oder Alkohol. Verwenden Sie keine Reinigungsmittel mit ätzenden Chemikalien.

[EN]

Warning: Please read instructions fully before starting assembly. Check you have all the components and tools listed on pages.

Warning: Please place all parts on a flat surface. Place a soft blanket or similar underneath to protect against scratches or stains. Avoid dragging or sliding components across the floor.

Warning: Regularly check all fittings and fastenings to ensure they are secure and to prevent accidents. If any parts are missing, broken, damaged, or worn, discontinue use of the product until repairs have been made using factory authorized parts.

Warning: Do not allow children to climb on the furniture as this may result in tipping and serious personal injury. Assemble the furniture away from the reach of children.

Warning: Do not place furniture close to fire sources or high-temperature objects to avoid the risk of fire.

Warning: Clean furniture with a damp cloth or alcohol, avoid using cleaning agents containing corrosive chemicals.

[FR]

Avertissement : Veuillez lire entièrement les instructions avant de commencer l'assemblage. Vérifiez que vous disposez de tous les composants et outils répertoriés sur les pages.

Avertissement : Veuillez placer toutes les pièces sur une surface plane. Placez une couverture douce ou similaire en dessous pour les protéger des rayures ou des taches. Évitez de faire glisser les composants sur le sol.

Avertissement : Vérifiez régulièrement tous les raccords et fixations pour vous assurer qu'ils sont bien fixés et pour éviter les accidents. Si des pièces manquent, sont cassées, endommagées ou usées, cessez d'utiliser le produit jusqu'à ce que des réparations aient été effectuées à l'aide de pièces autorisées par l'usine.

Avertissement : Ne laissez pas les enfants grimper sur les meubles car cela pourrait entraîner un basculement et des blessures graves. Assemblez les meubles hors de portée des enfants.

Avertissement : Ne placez pas les meubles à proximité de sources de feu ou d'objets à haute température pour éviter tout risque d'incendie.

Avertissement : Nettoyez les meubles avec un chiffon humide ou de l'alcool, évitez d'utiliser des produits de nettoyage contenant des produits chimiques corrosifs.



[IT]

Attenzione: leggere attentamente le istruzioni prima di iniziare il montaggio. Verificare di avere tutti i componenti e gli strumenti elencati nelle pagine.

Attenzione: posizionare tutte le parti su una superficie piana. Posizionare una coperta morbida o simile sotto per proteggere da graffi o macchie. Evitare di trascinare o far scivolare i componenti sul pavimento.

Attenzione: controllare regolarmente tutti i raccordi e i dispositivi di fissaggio per assicurarsi che siano sicuri e per prevenire incidenti. Se alcune parti sono mancanti, rotte, danneggiate o usurate, interrompere l'uso del prodotto fino a quando non siano state eseguite le riparazioni utilizzando parti autorizzate dalla fabbrica.

Attenzione: non consentire ai bambini di arrampicarsi sui mobili poiché ciò potrebbe causare ribaltamenti e gravi lesioni personali. Montare i mobili lontano dalla portata dei bambini.

Attenzione: non posizionare i mobili vicino a fonti di fuoco o oggetti ad alta temperatura per evitare il rischio di incendio.

Attenzione: pulire i mobili con un panno umido o alcol, evitare di utilizzare detergenti contenenti sostanze chimiche corrosive.

[ES]

Advertencia: Lea las instrucciones completamente antes de comenzar el montaje. Compruebe que tiene todos los componentes y herramientas que se enumeran en las páginas.

Advertencia: Coloque todas las piezas sobre una superficie plana. Coloque una manta suave o algo similar debajo para protegerlas de rayones o manchas. Evite arrastrar o deslizar los componentes por el piso.

Advertencia: Verifique regularmente todos los accesorios y fijaciones para asegurarse de que estén seguros y evitar accidentes. Si falta alguna pieza, está rota, dañada o desgastada, deje de usar el producto hasta que se hayan realizado las reparaciones con piezas autorizadas de fábrica.

Advertencia: No permita que los niños se suban a los muebles, ya que esto puede provocar que se vuelquen y lesiones personales graves. Monte los muebles fuera del alcance de los niños.

Advertencia: No coloque los muebles cerca de fuentes de fuego u objetos de alta temperatura para evitar el riesgo de incendio.

Advertencia: Limpie los muebles con un paño húmedo o alcohol, evite usar agentes de limpieza que contengan químicos corrosivos.

Importer	COMHARBOR LIMITED
ADD	WAREHOUSE1&HEADOFFICE,UNITC, SWIFTPPOINT,
Email	harborcumhar@gmail.com
Manufacturer	SHANDONG YIJUMUZHAI SMART HOME CO.,LTD
ADD	1666M EAST OFJINGUANGSTREETBRIDGE, LUOCHENGTOWN,SHOUGUANGCITY,WEIFANG CITY,SHANDONG PROVINCE
EmaiVURL	http://www.yinjumuzhai.com

OPTION 1

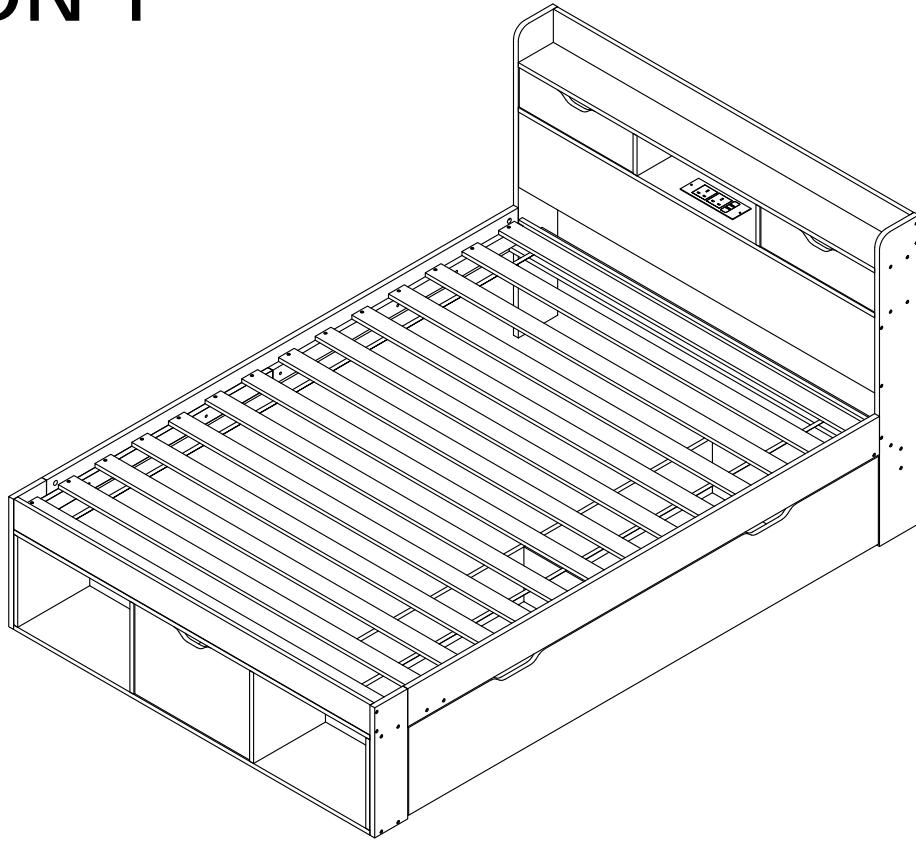

OPTION 2

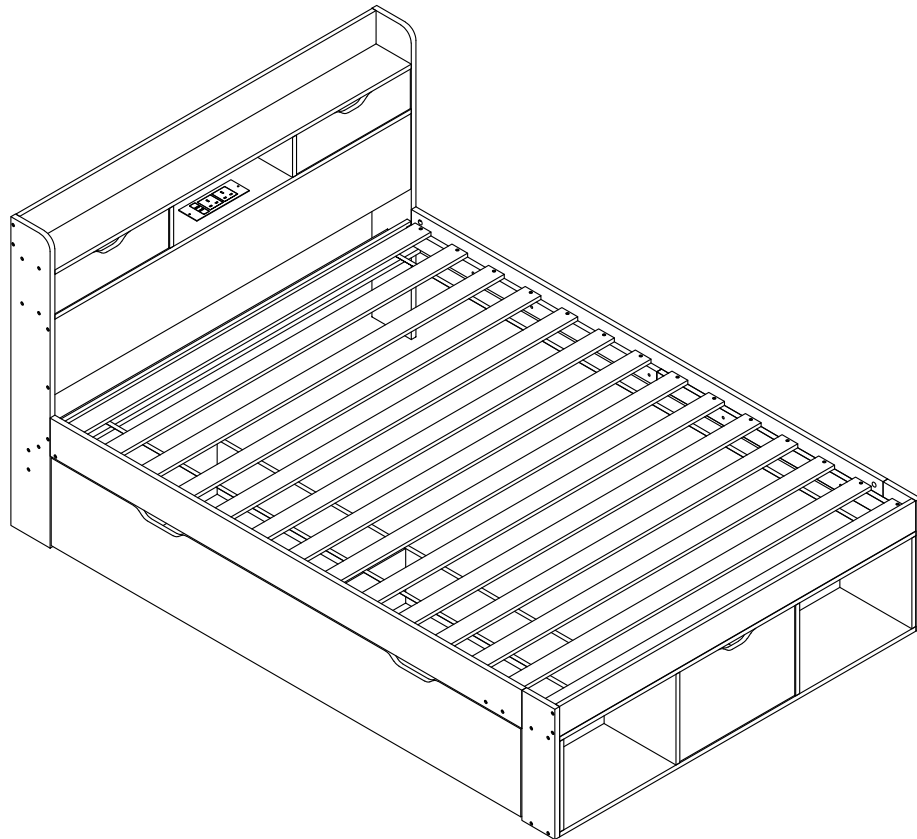



Parts List

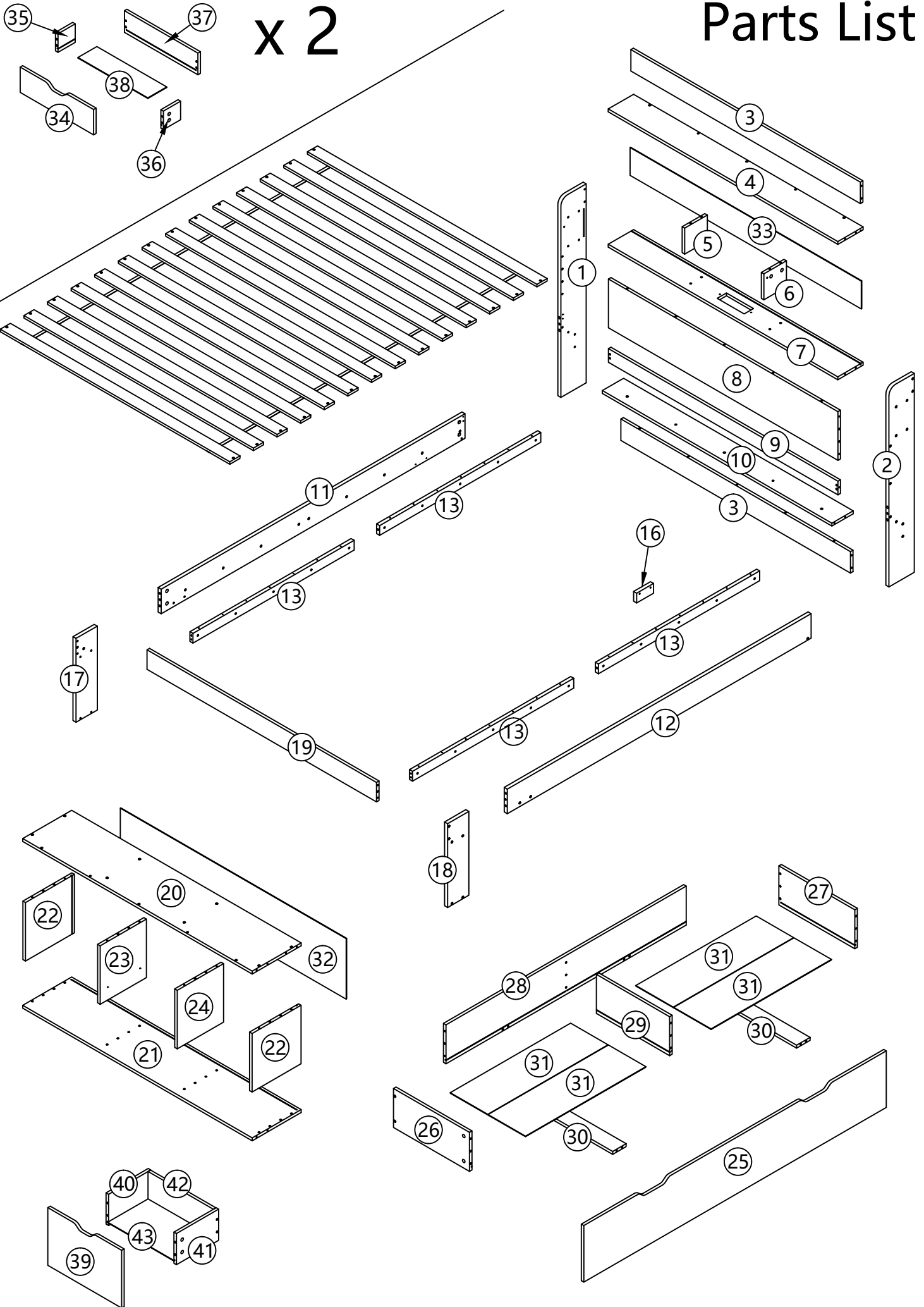

x 2

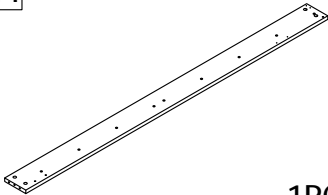
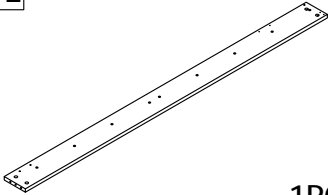
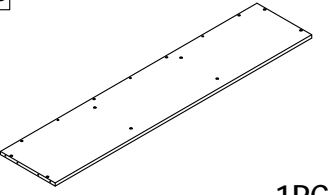
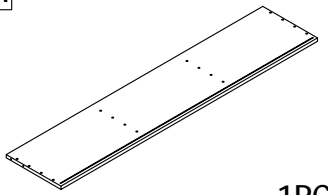
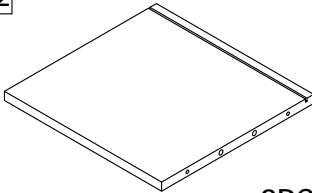
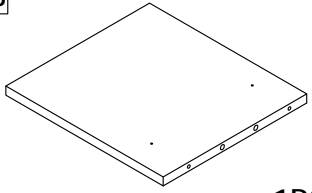
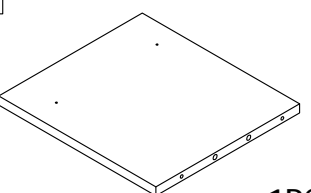
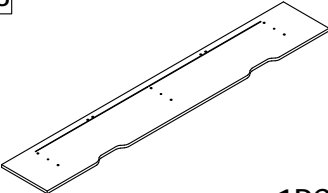
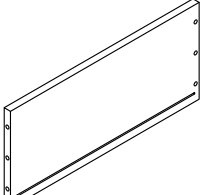
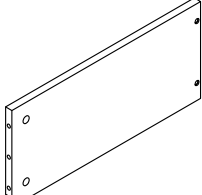
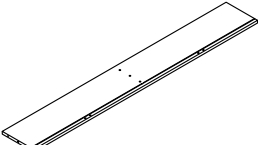
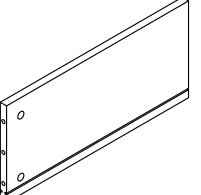
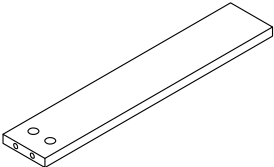
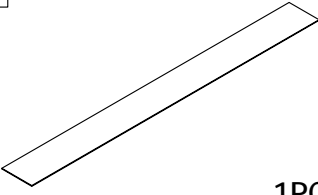
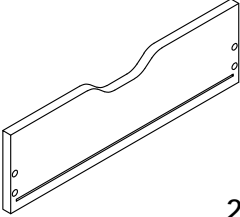

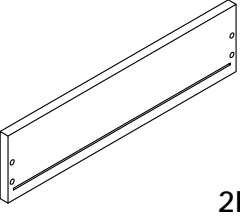
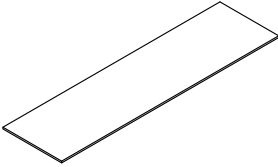
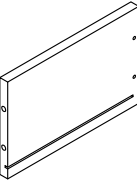
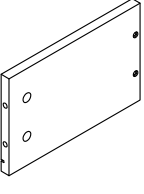
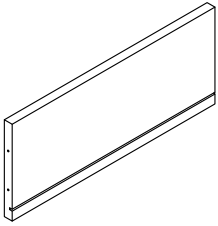
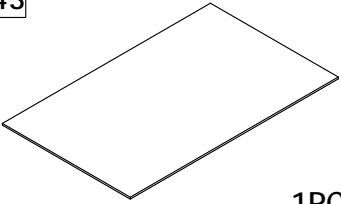
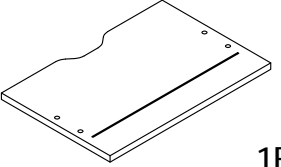



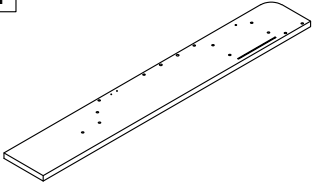
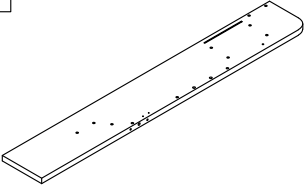
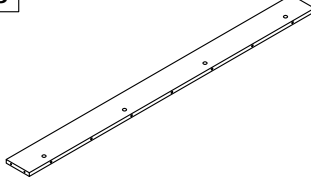
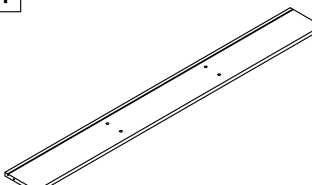
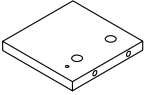
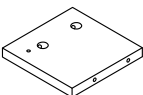
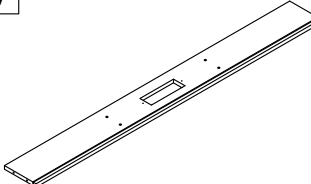
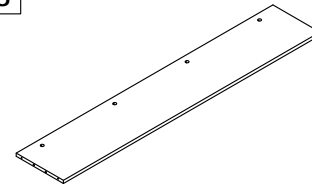
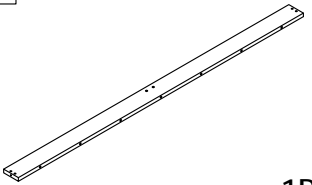
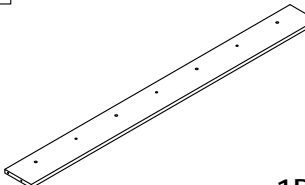
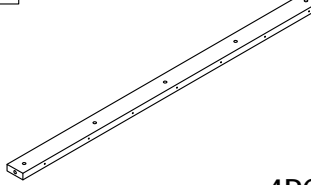

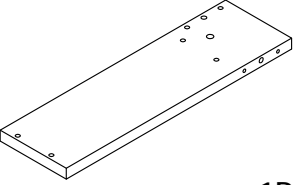
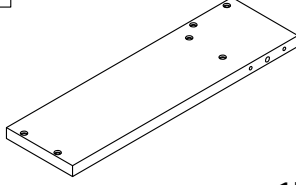
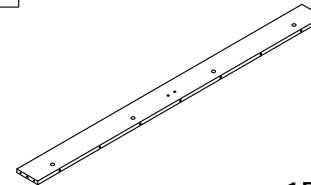
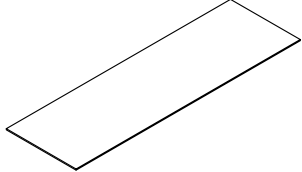
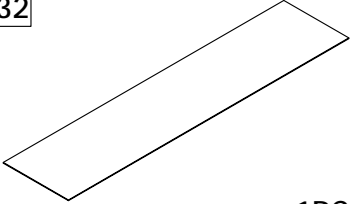
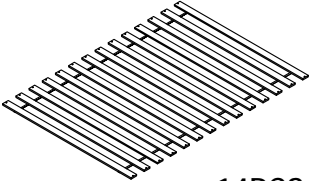
N634P362416W

11  1PC	12  1PC	20  1PC	21  1PC
22  2PCS	23  1PC	24  1PC	25  1PC
26  1PC	27  1PC	28  1PC	29  1PC
30  2PCS	33  1PC	34  2PCS	35  2PCS
36  2PCS	37  2PCS	38  2PCS	40  1PC
41  1PC	42  1PC	43  1PC	39  1PC

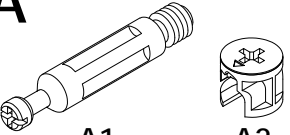
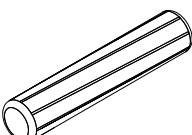
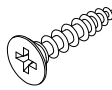
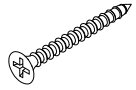
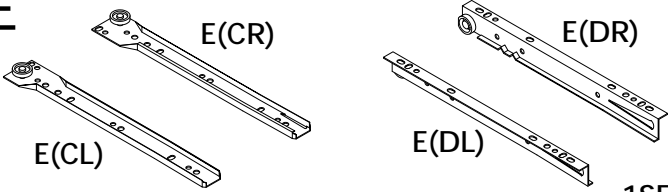
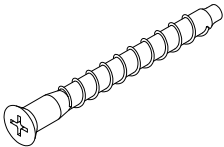
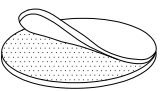
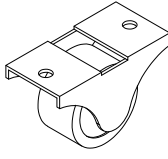
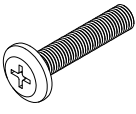
N634P362417W

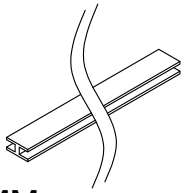
<p>1</p>  <p>1PC</p>	<p>2</p>  <p>1PC</p>	<p>3</p>  <p>2PCS</p>	<p>4</p>  <p>1PC</p>
<p>5</p>  <p>1PC</p>	<p>6</p>  <p>1PC</p>	<p>7</p>  <p>1PC</p>	<p>8</p>  <p>1PC</p>
<p>9</p>  <p>1PC</p>	<p>10</p>  <p>1PC</p>	<p>13</p>  <p>4PCS</p>	<p>16</p>  <p>1PC</p>
<p>17</p>  <p>1PC</p>	<p>18</p>  <p>1PC</p>	<p>19</p>  <p>1PC</p>	<p>31</p>  <p>4PCS</p>
<p>32</p>  <p>1PC</p>		 <p>14PCSx1</p>	

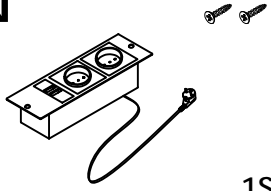
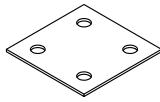
Hardware N634P362417W

<p>A</p>  <p>A1 A2 49STES</p>	<p>B</p>  <p>8 x 40MM 22PCS</p>	<p>C</p>  <p>3.5 x 14MM 48PCS</p>	<p>D</p>  <p>3.5 x 30MM 42PCS</p>
<p>E</p>  <p>E(CR) E(DR) E(DL) E(CL) 1SET</p>		<p>F</p>  <p>5 x 38MM 76PCS</p>	<p>G</p>  <p>82PCS</p>
<p>H</p>  <p>6PCS</p>	<p>J</p>  <p>6 x 30MM 20PCS</p>	<p>K</p>  <p>24PCS</p>	<p>L</p>  <p>705MM 2PCS</p>
<p>M</p>  <p>4PCS</p>	<p>N</p>  <p>1SET</p>	<p>Q</p>  <p>2PCS</p>	<p>R</p>  <p>6 x 30MM 22PCS</p>
<p>S</p>  <p>3.5 x 12MM 4PCS</p>			

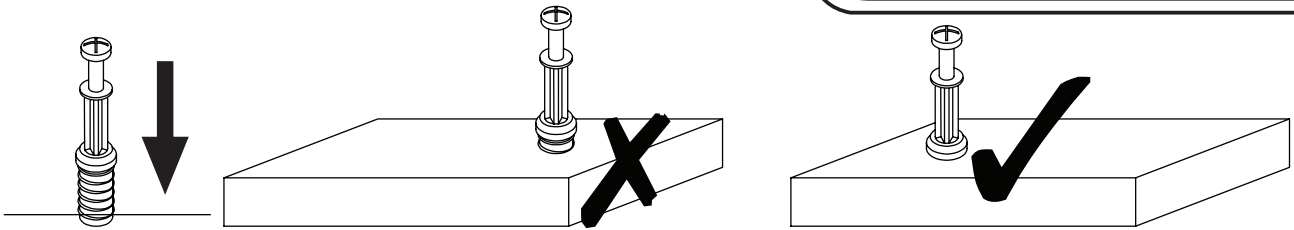

EN_QUICKFIT: Tighten quickfit until shoulder is flush with panel. Do not overtighten or undertighten.

FR_RACCORD RAPIDE: Faites serrer le raccord rapide jusqu'à ce que l'épaulement soit parfaitement encastré dans le panneau. Il ne faut ni trop serrer ni insuffisamment serrer.

ES_QUICKFIT: Apriete quickfit hasta que el hombro se descargue con el panel. NO lo sobreapriete ni lo apriete poco.

DE_QUICKFIT: Ziehen Sie den Quickfit fest, bis die Schulter mit der Platte bündig ist. Bitte nicht zu fest oder zu schwach anziehen.

IT_MONTAGGIO RAPIDO: Stringere il montaggio rapido fino a quando la spalla è a filo con il pannello, non stringere troppo o troppo poco.

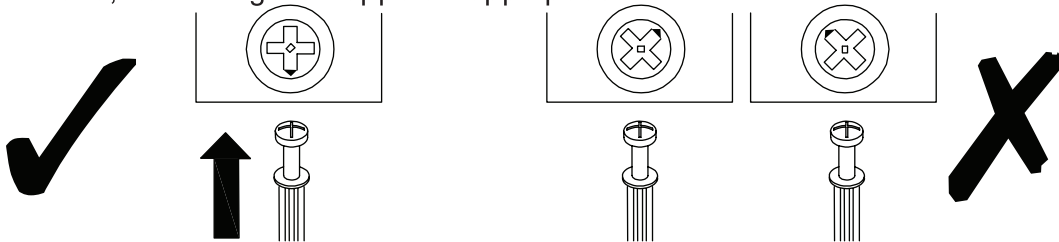

EN_CAM LOCK: When fitting cam lock, ensure starting position is correct before you insert connecting quickfit.

FR_SERRURE BATTEUSE: Avant d'insérer la serrure batteuse, veillez à la bonne orientation avant d'insérer le raccord rapide.

ES_CIERRE DE LA CÁMARA: Cuando instale el cierre de la cámara, asegúrese de que la posición de inicio es correcta antes de que inserte el quickfit conector.

DE_CAM-LOCK: Achten Sie bei der Montage des Cam-Locks auf die richtige Ausgangsposition, bevor Sie den Quickfit einsetzen.

IT_BLOCCAGGIO A CAMMA: Quando si monta il bloccaggio a camma, assicurarsi che la posizione iniziale sia corretta prima di inserire il montaggio rapido di collegamento.

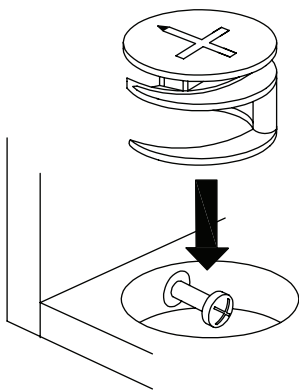

EN_Quickfit head should be in the centre of the cam lock when the two panels are joined.

Cam lock should be inserted before quickfit.

FR_Lorsque les deux panneaux sont assemblés, la tête du raccord rapide doit reposer au centre de la serrure batteuse. Il faut insérer la serrure batteuse avant le raccord rapide.

ES_El cabezal del quickfit debe estar en el centro del cierre de la cámara cuando se unan los dos paneles.

Se debe insertar el cierre de la cámara antes que el quickfit.

DE_Der Quickfit-Kopf sollte sich in der Mitte des Cam-Locks befinden, wenn die beiden Platten zusammengefügt sind. Der Cam-Lock sollte vor dem Quickfit eingesetzt werden.

IT_La testa del montaggio rapido deve trovarsi al centro del bloccaggio a camma quando i due pannelli sono uniti.

Il Bloccaggio a Camma deve essere inserito prima del montaggio rapido.

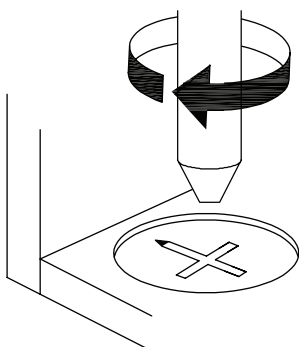

EN_Turn cam lock clockwise to tighten.

FR_Faites tourner la serrure batteuse dans le sens des aiguilles d'une montre pour la resserrer.

ES_Gire el cierre de la cámara en sentido horario para apretarlo.

DE_Drehen Sie den Cam-Lock im Uhrzeigersinn, um ihn festzuziehen.

IT_Ruotare il bloccaggio a camma in senso orario per stringere.

1

A1

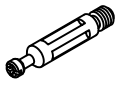

10PCS

B

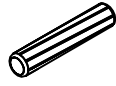

8 x 40MM

4PCS

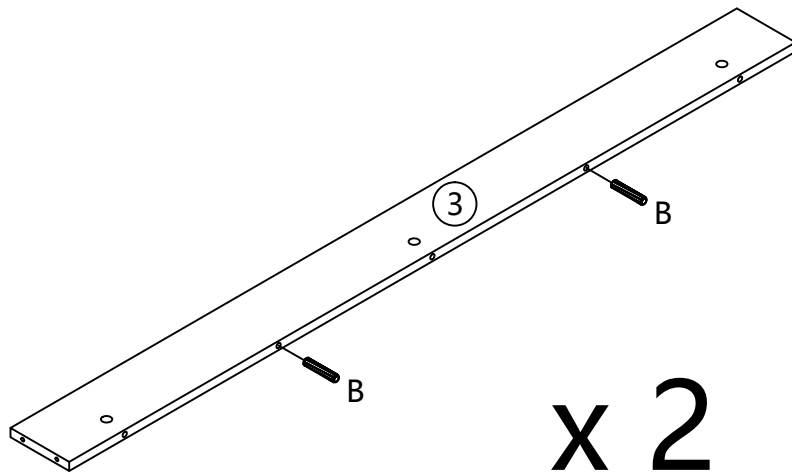
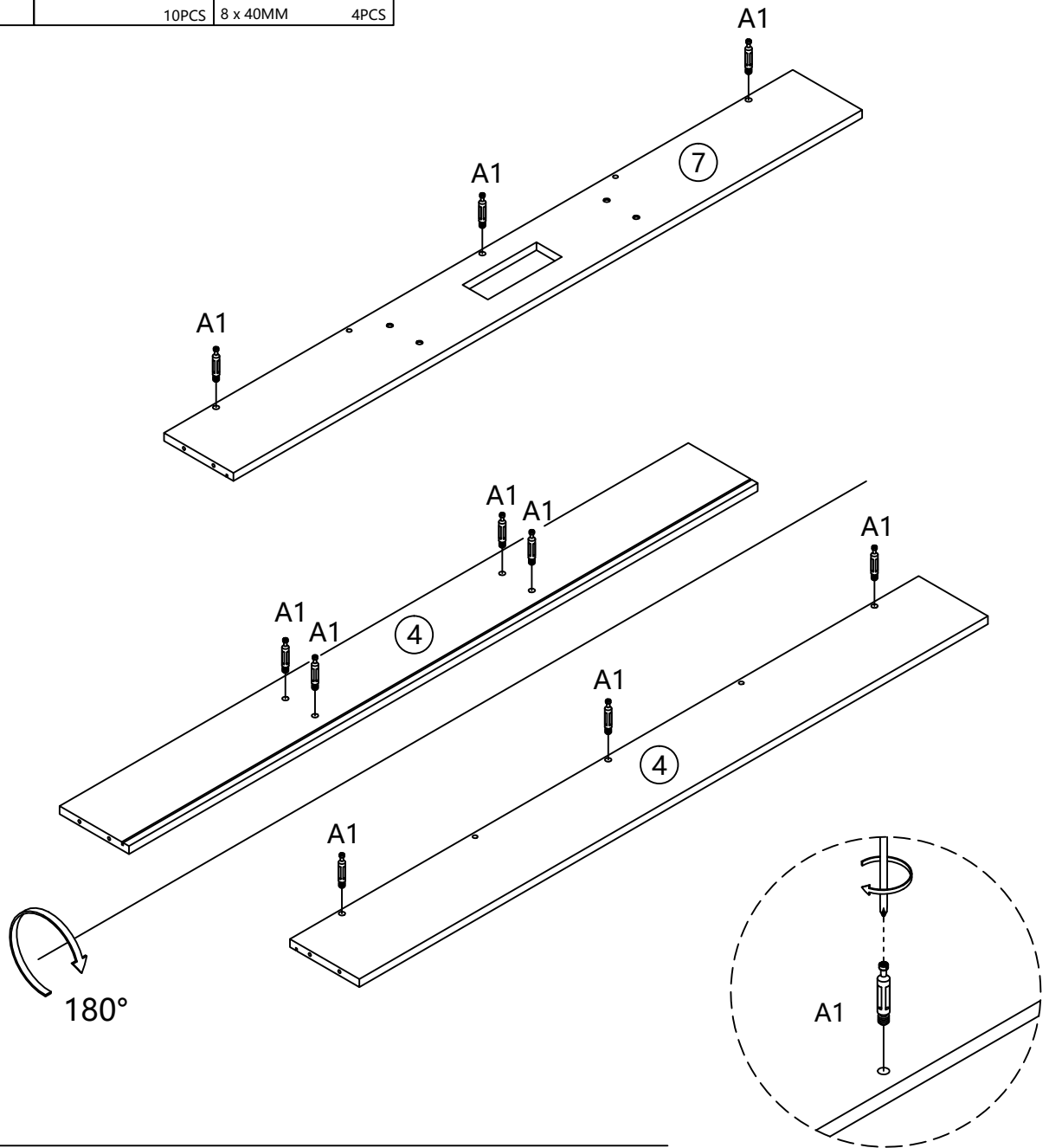

x 2

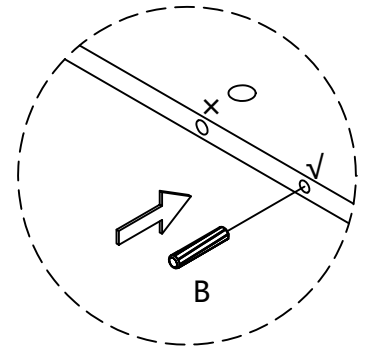

2

A1

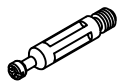

6PCS

B

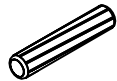

8 x 40MM

8PCS

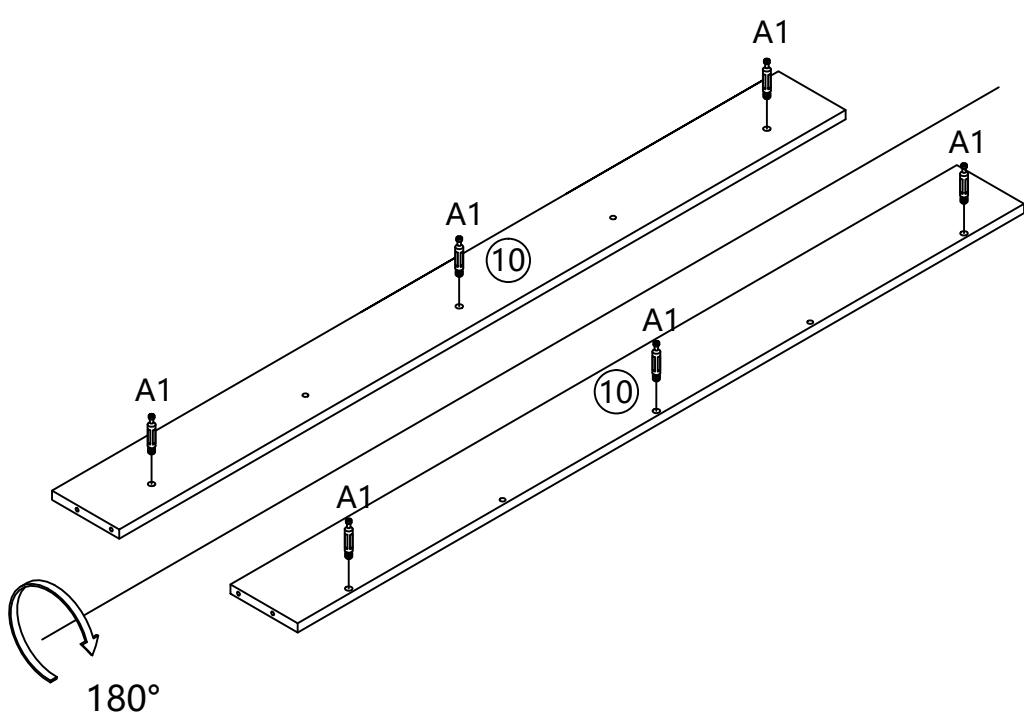
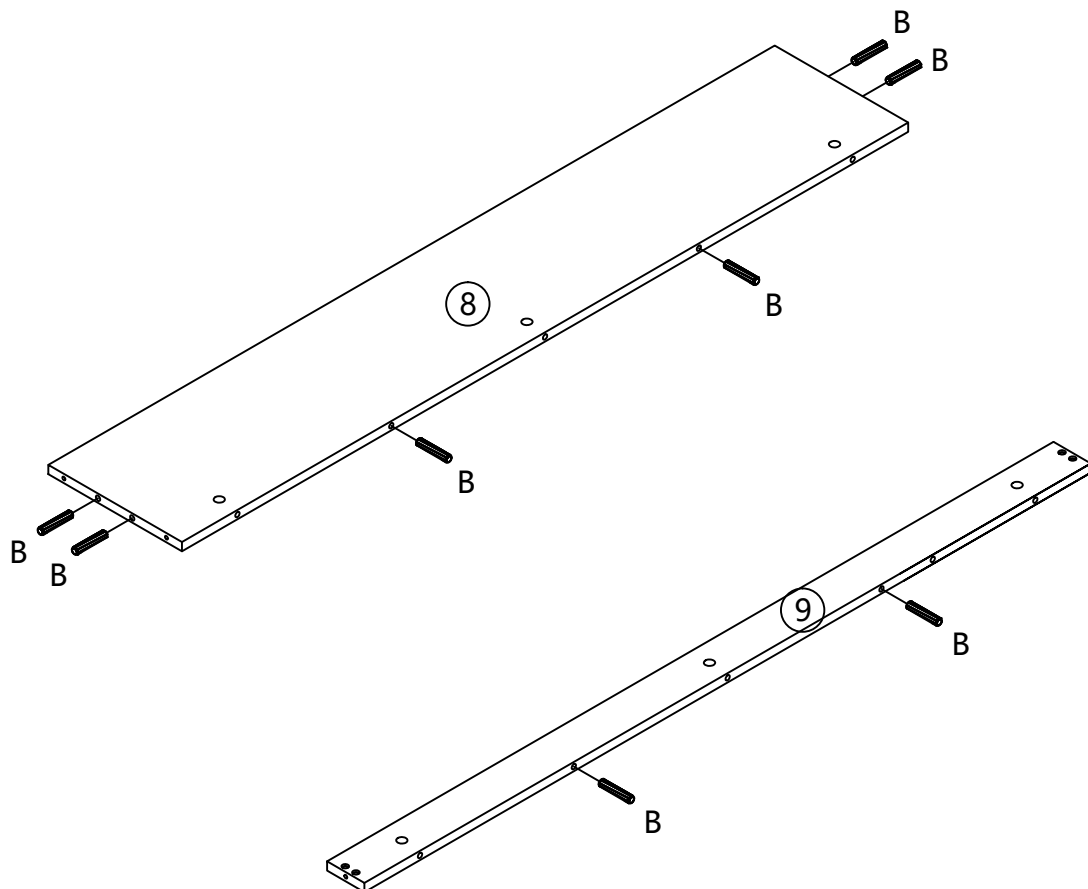

3

A2



10PCS

F

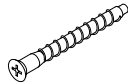

5 x 38MM

4PCS

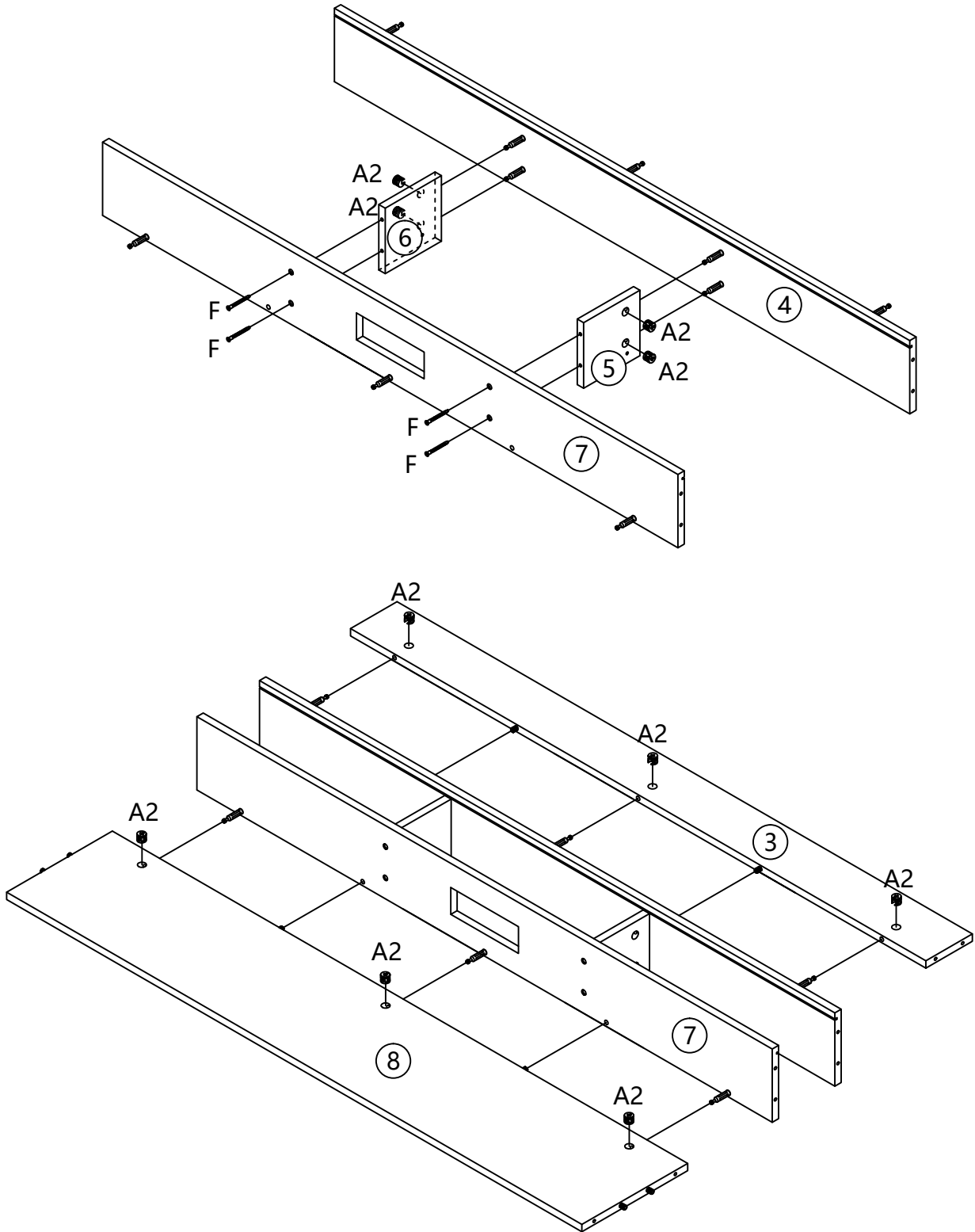
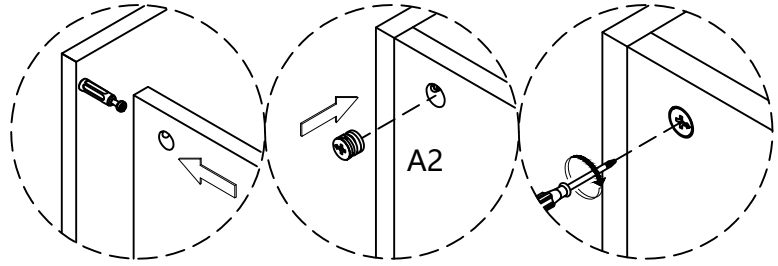

4

A2



6PCS

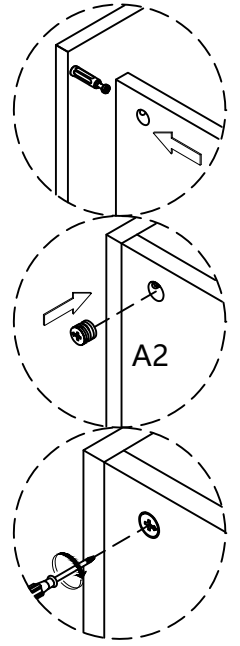
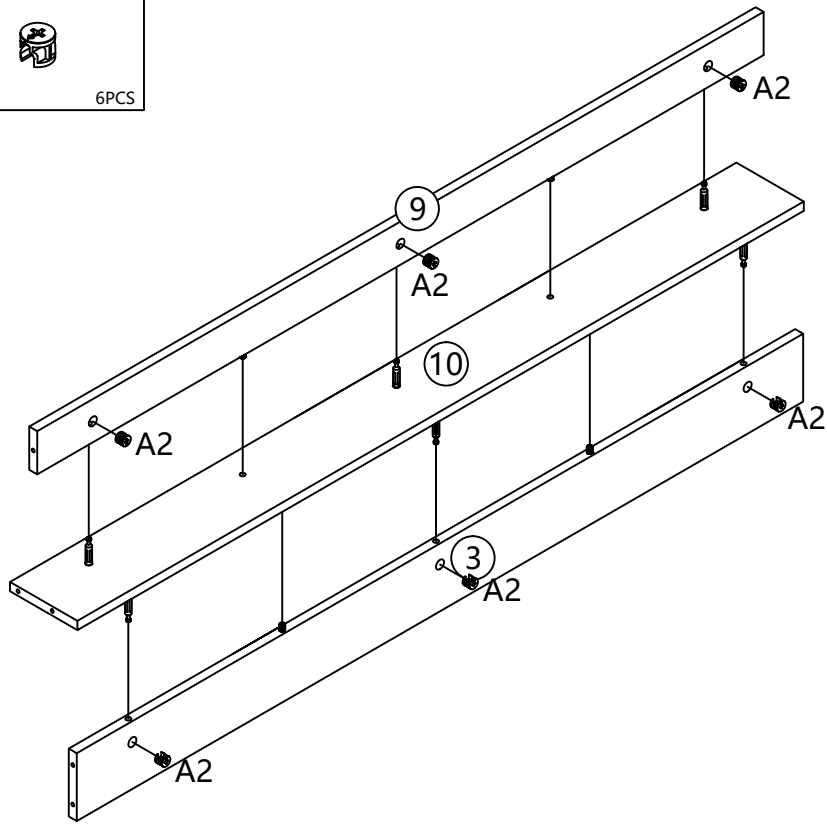

5

F

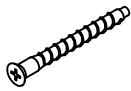

5 x 38MM

12PCS

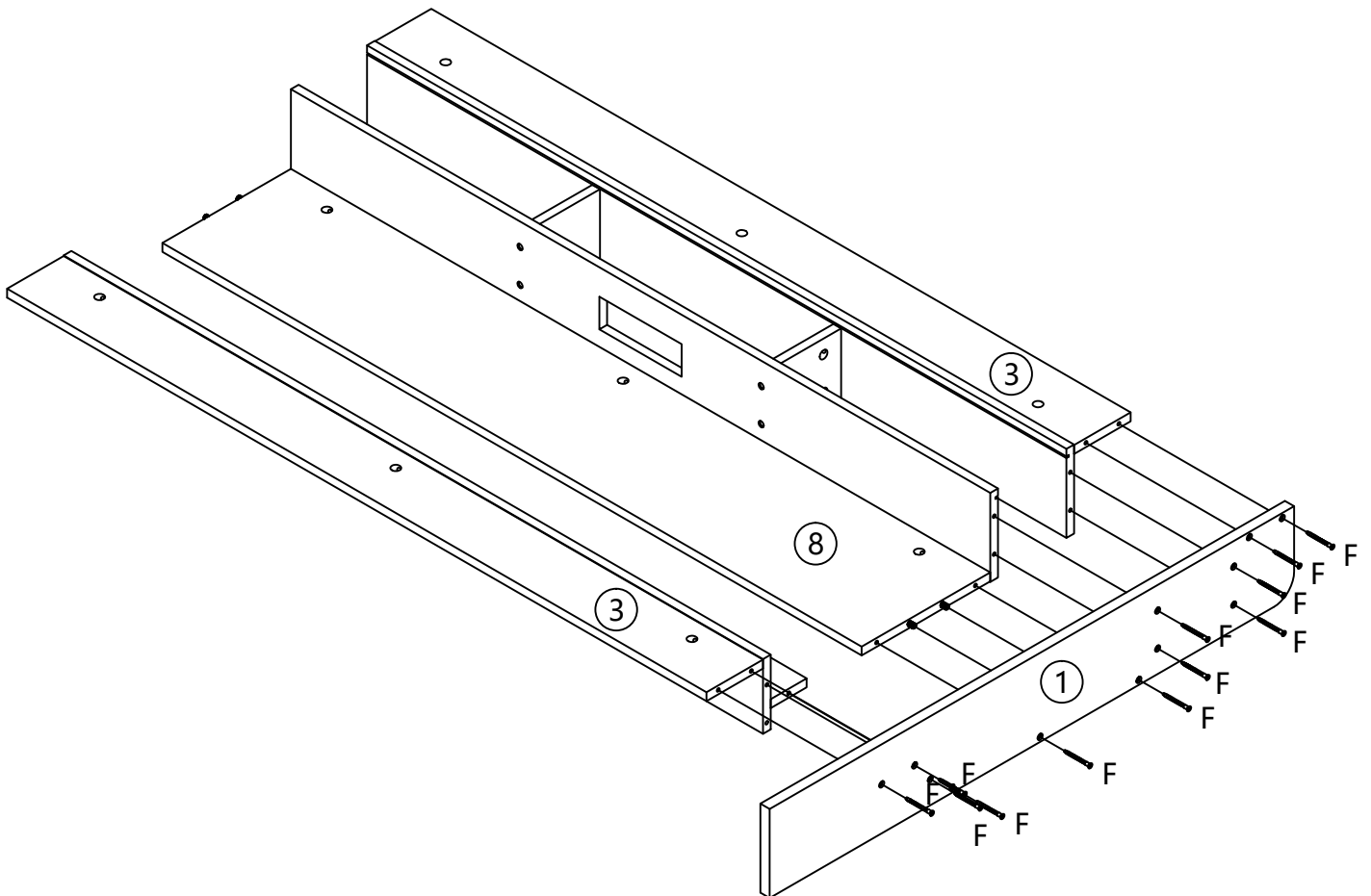

6

F

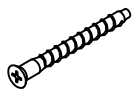

5 x 38MM

12PCS

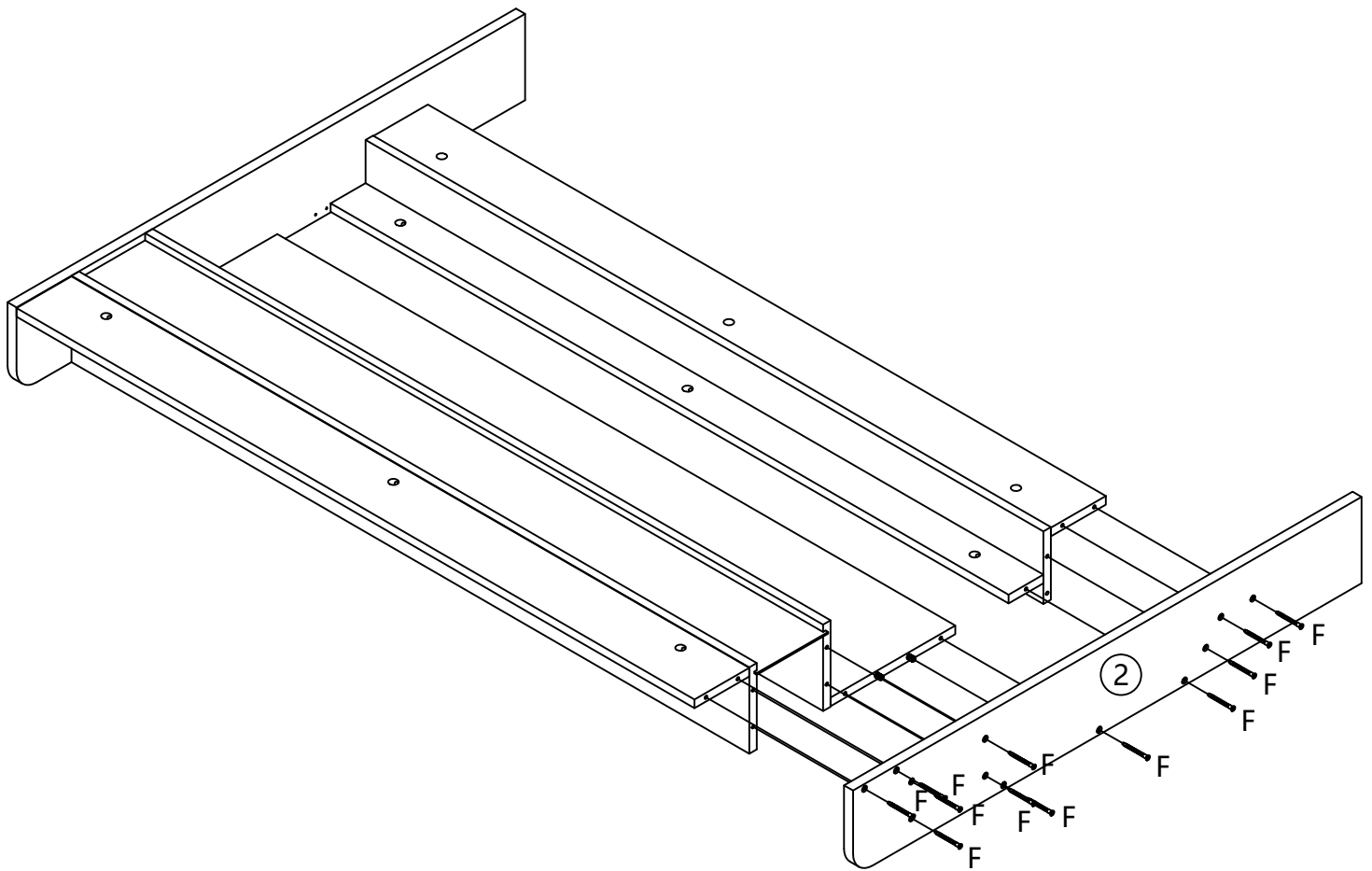
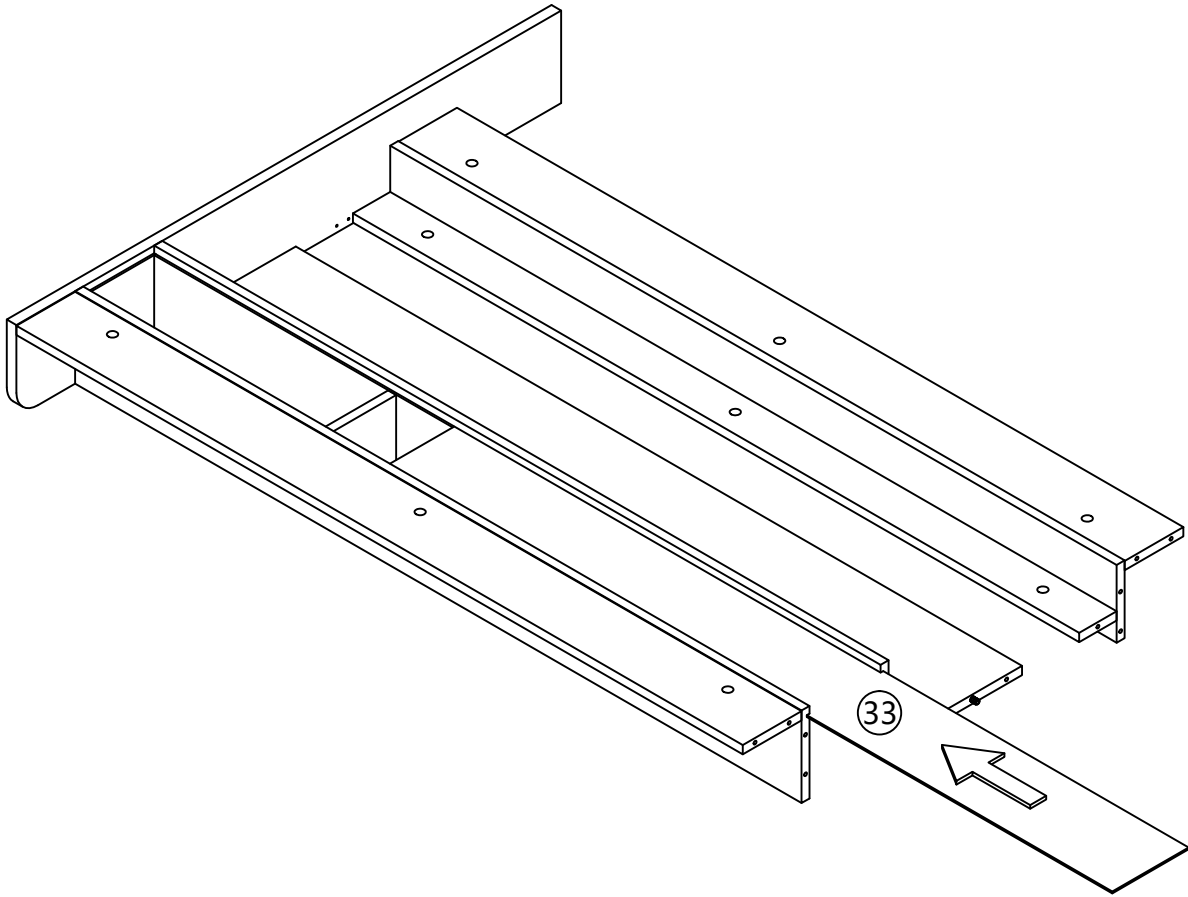

7

A1

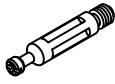

4PCS

C



3.5 x 14MM

6PCS

K



6PCS

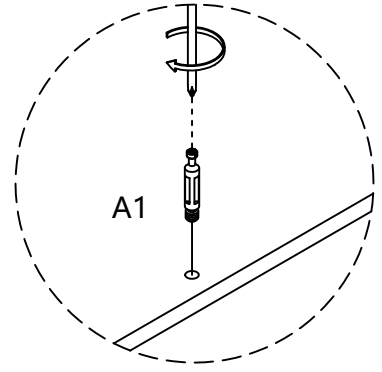
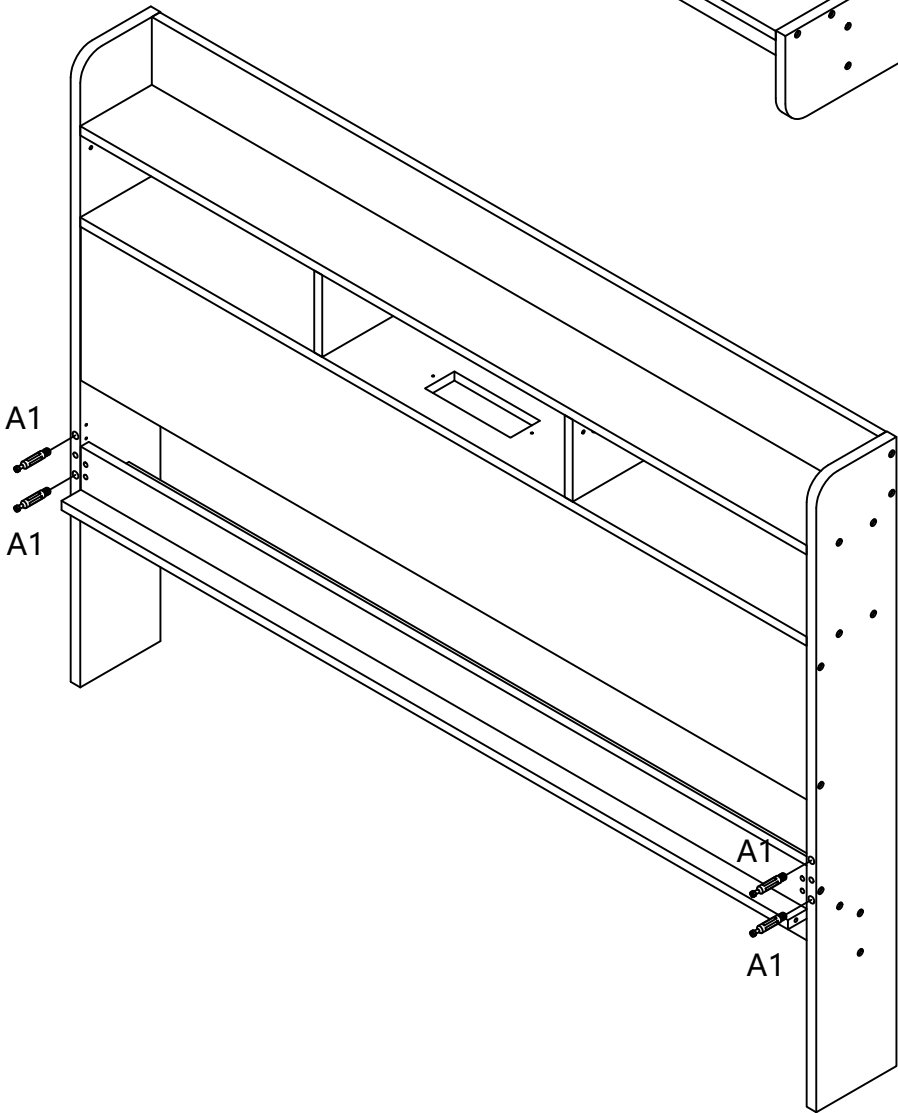
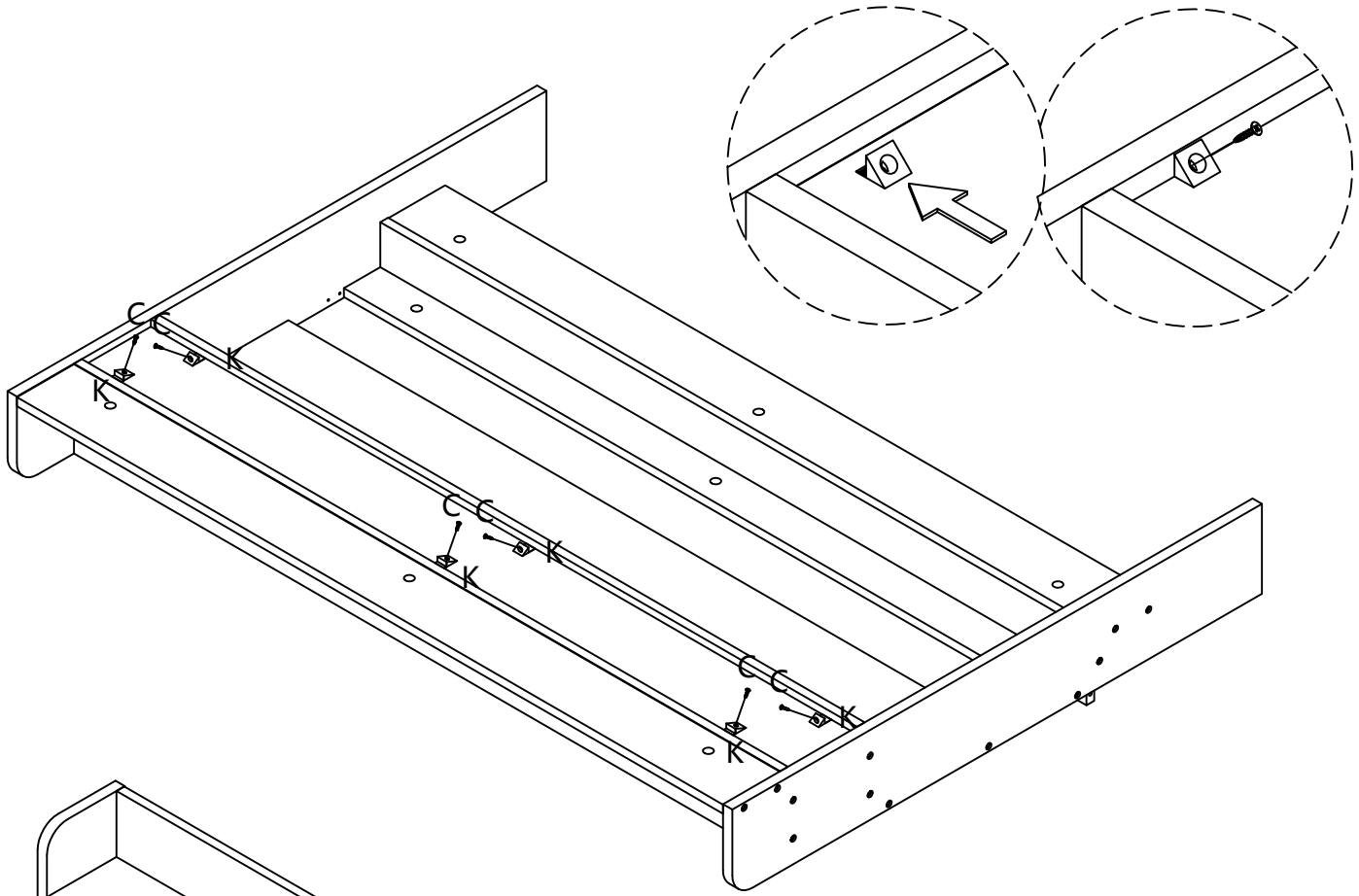

8

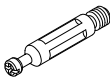
A1

3PCS

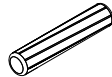
B

8 x 40MM

4PCS

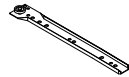
E(CL)

1PC

E(CR)

1PC

R

6 x 30MM

16PCS

S

3.5 x 12MM

4PCS

EN:Thissideupway
DE:DieseSeite nachoben
FR:Ce côté vers le haut
IT:Da questa parte verso l'alto
ES:De esta manera, con el lado hacia arriba

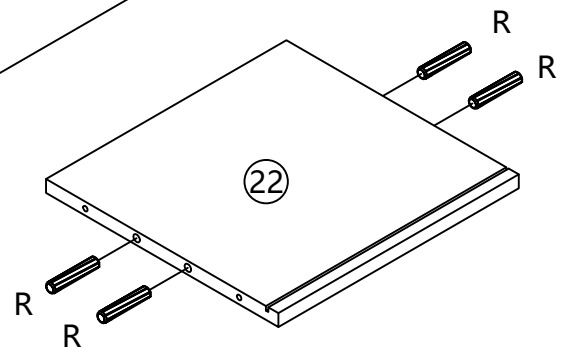
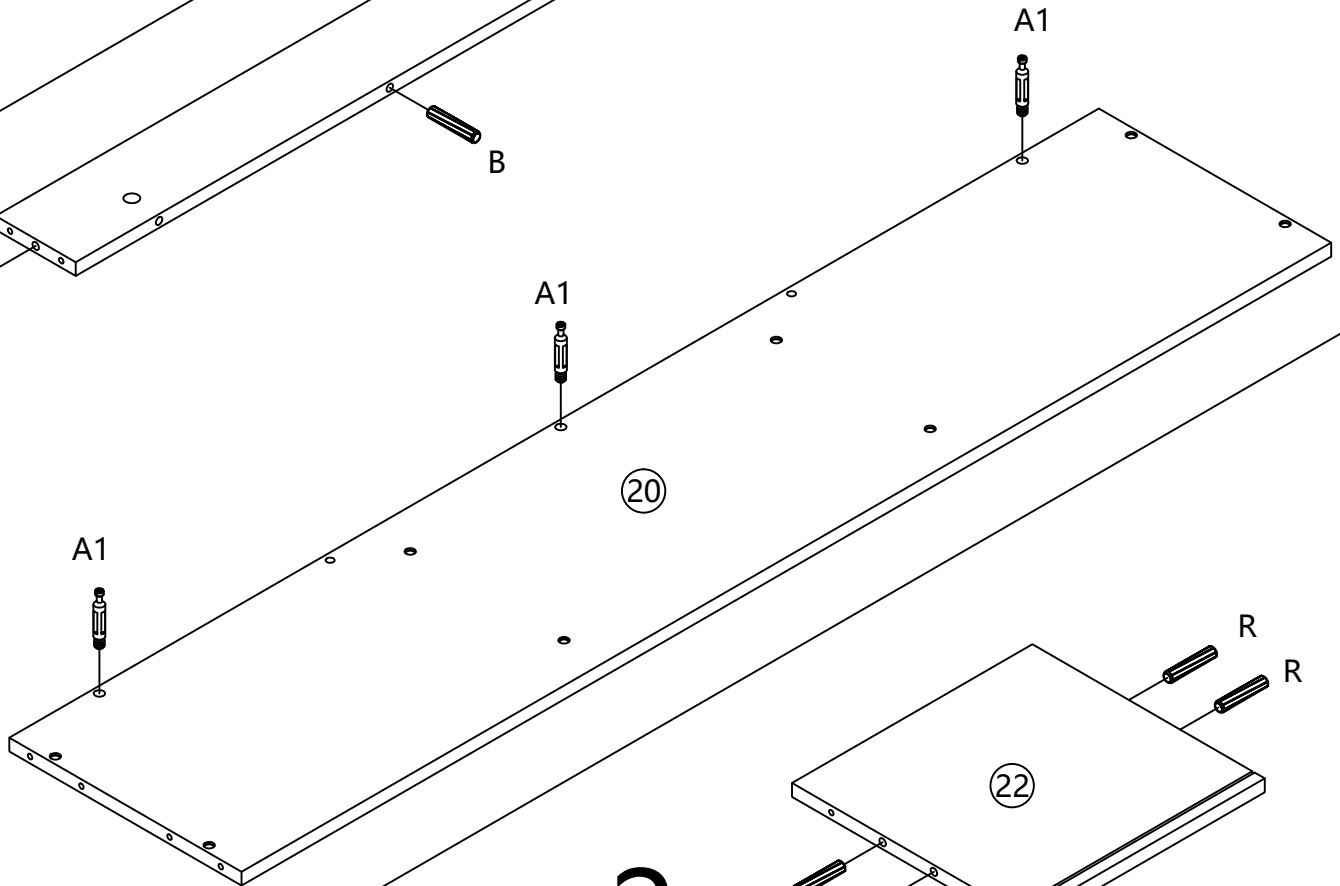
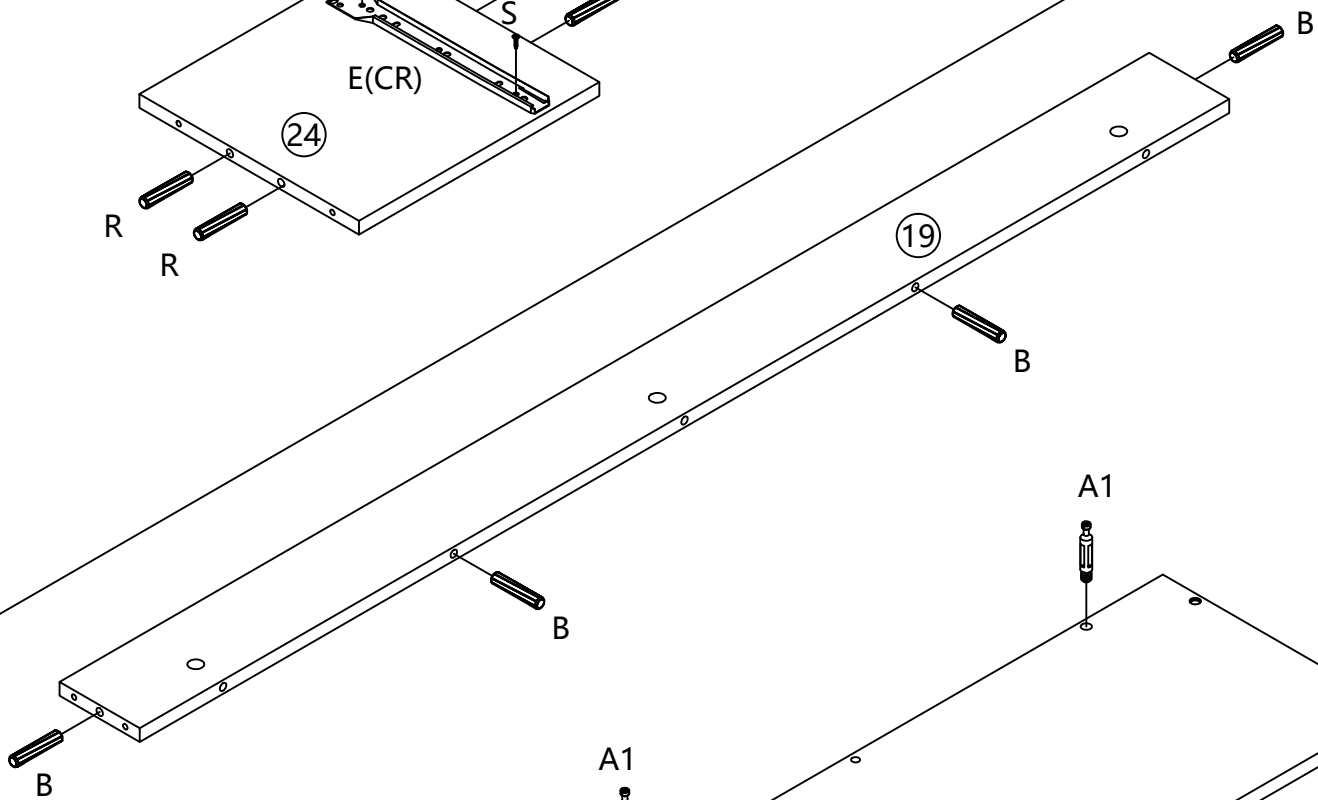
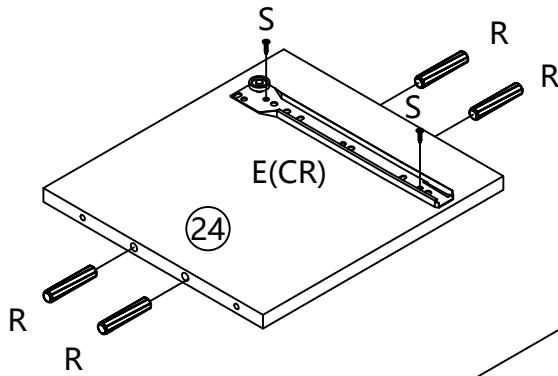
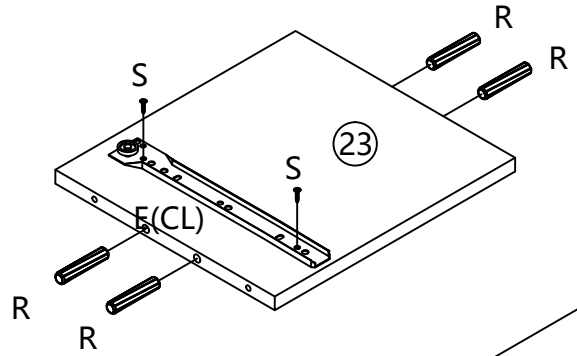
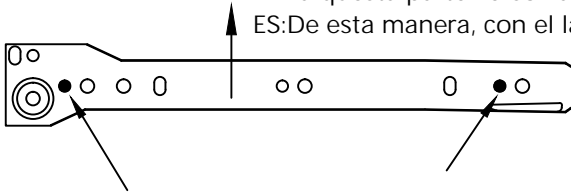

x 2

9

F

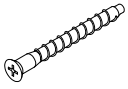

5 x 38MM

8PCS

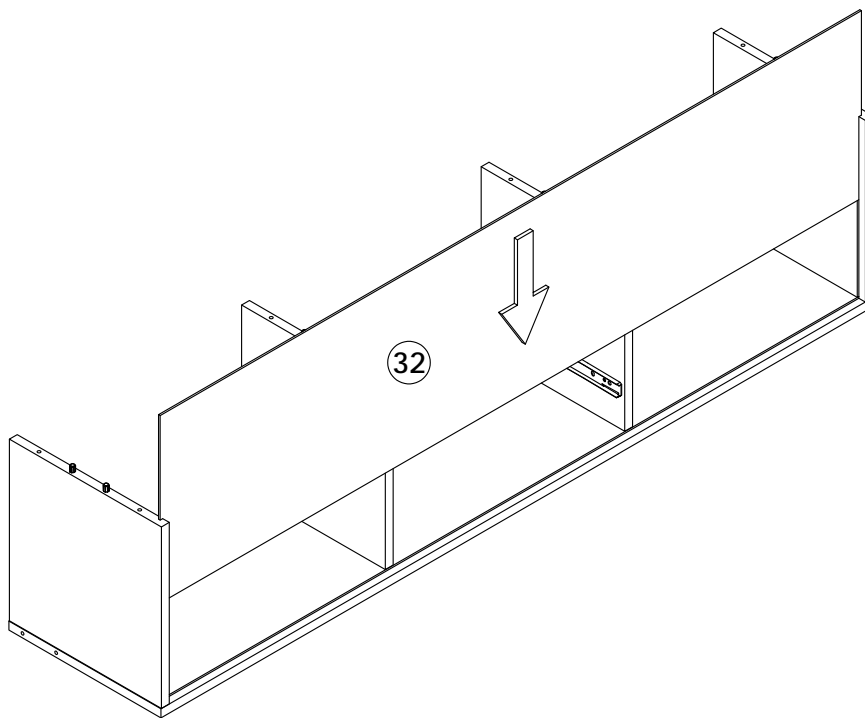
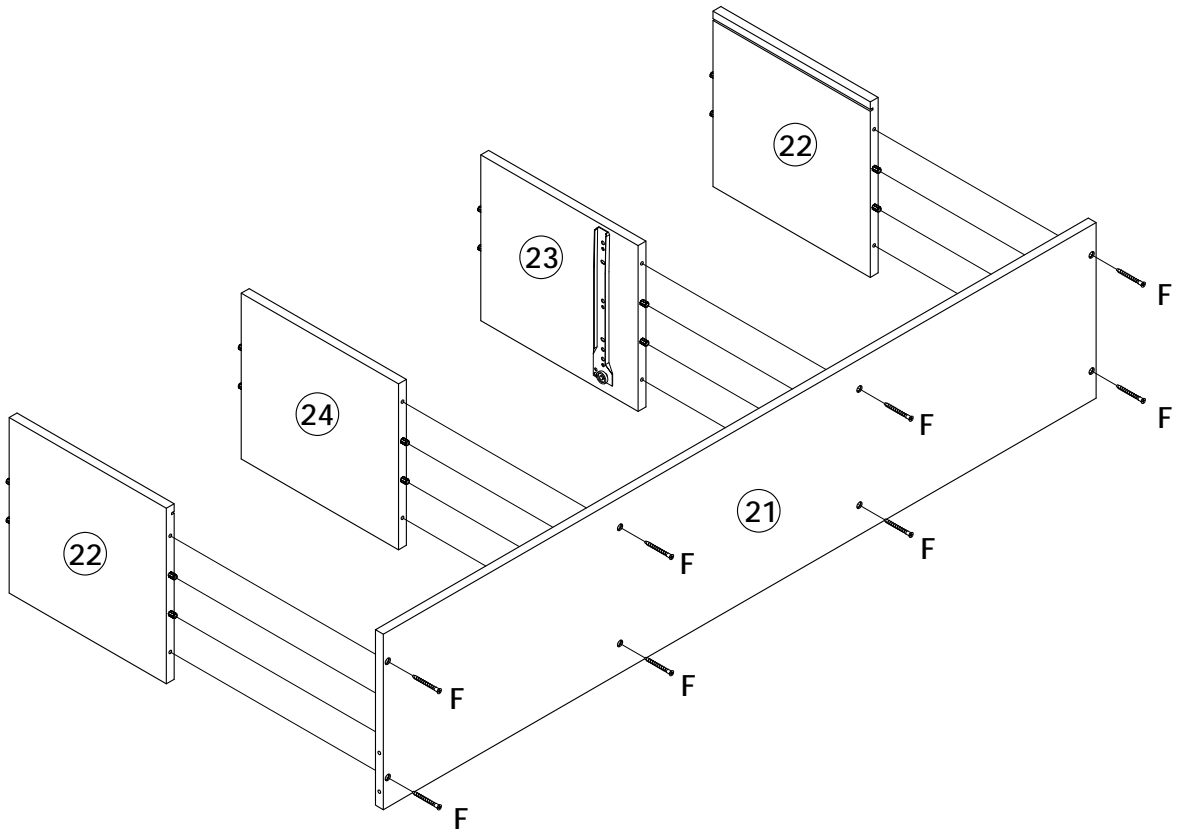

10

A2



3PCS

F



5 x 38MM

8PCS

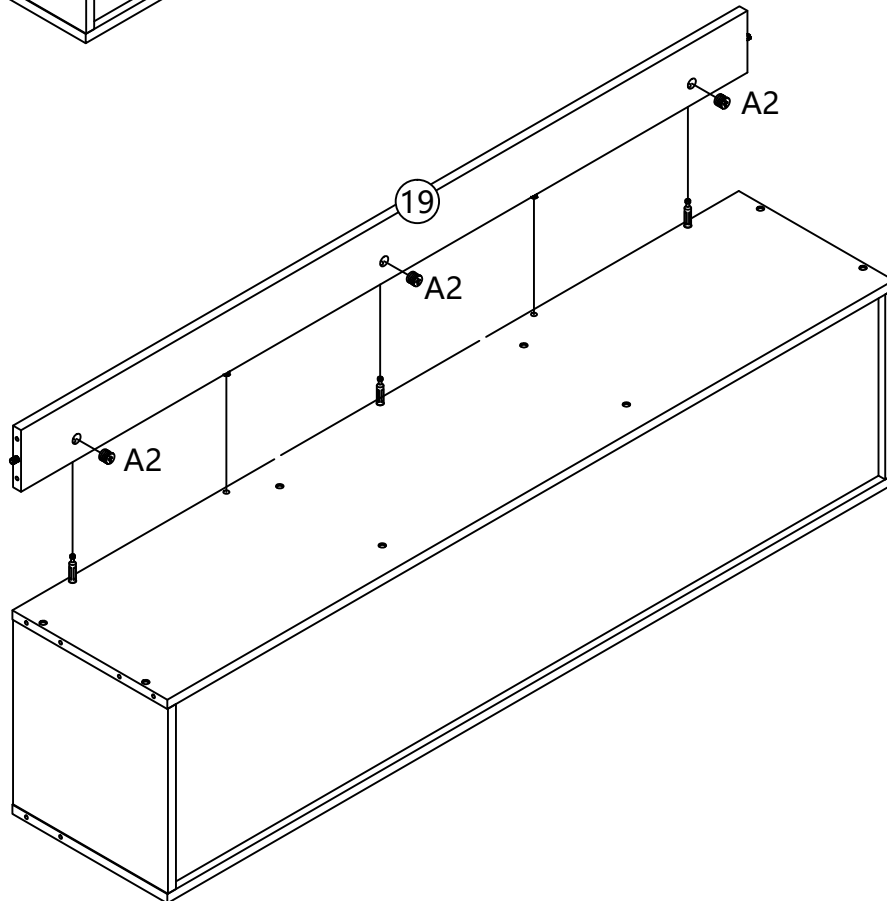
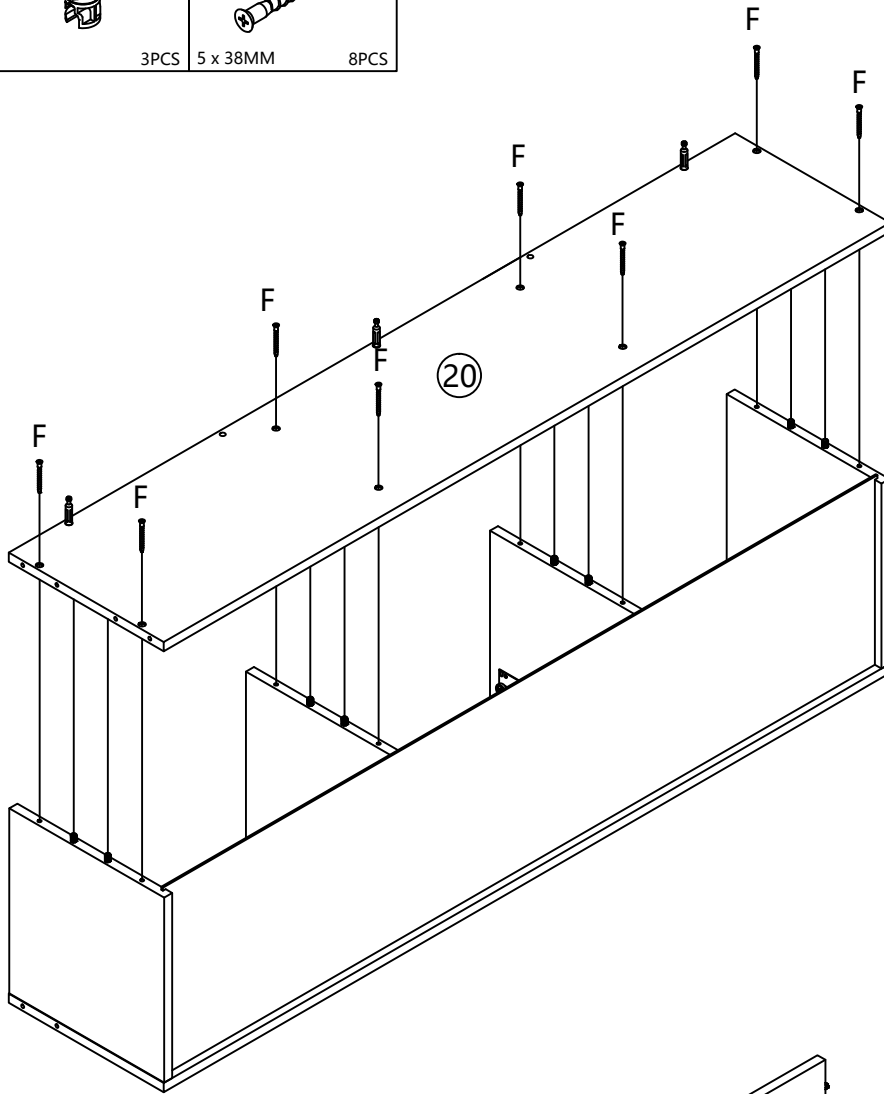

11

A1

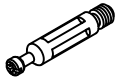

4PCS

C



3.5 x 14MM

6PCS

F

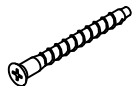

5 x 38MM

12PCS

K



6PCS

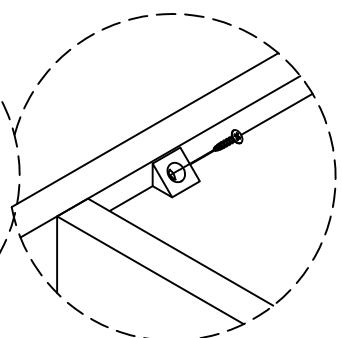
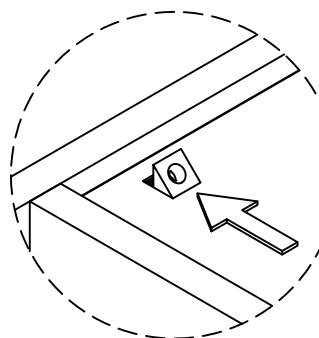
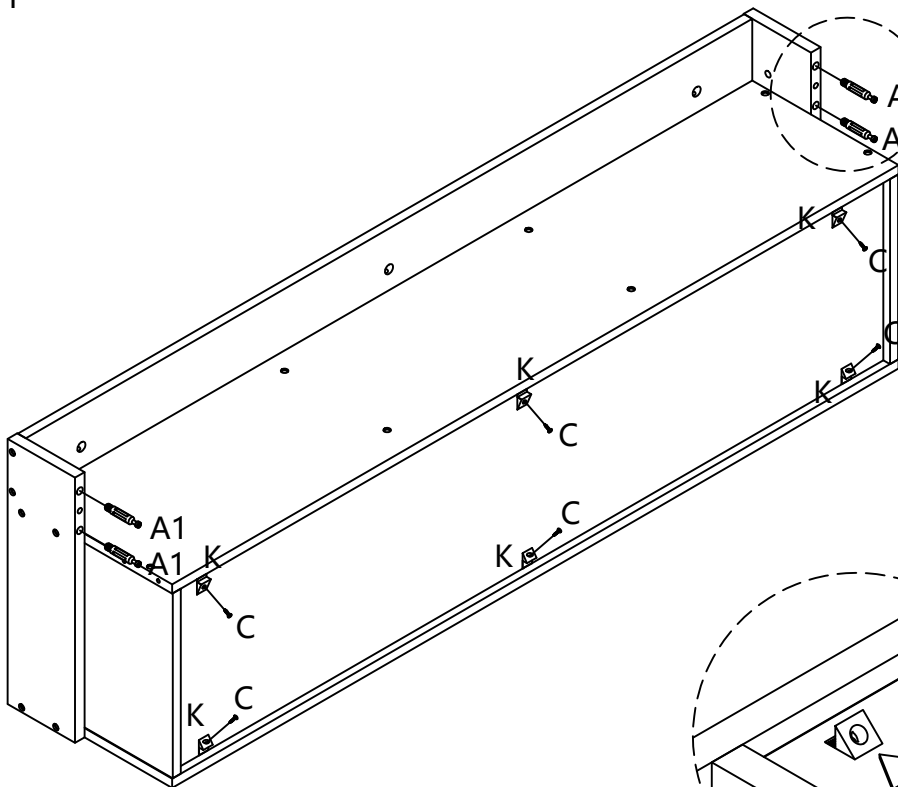
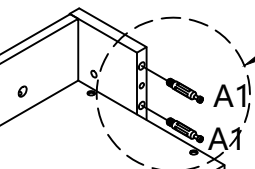
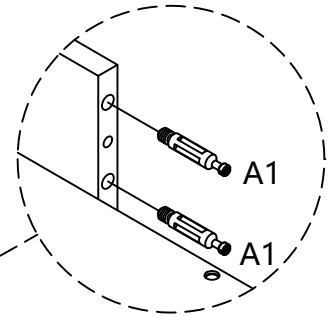
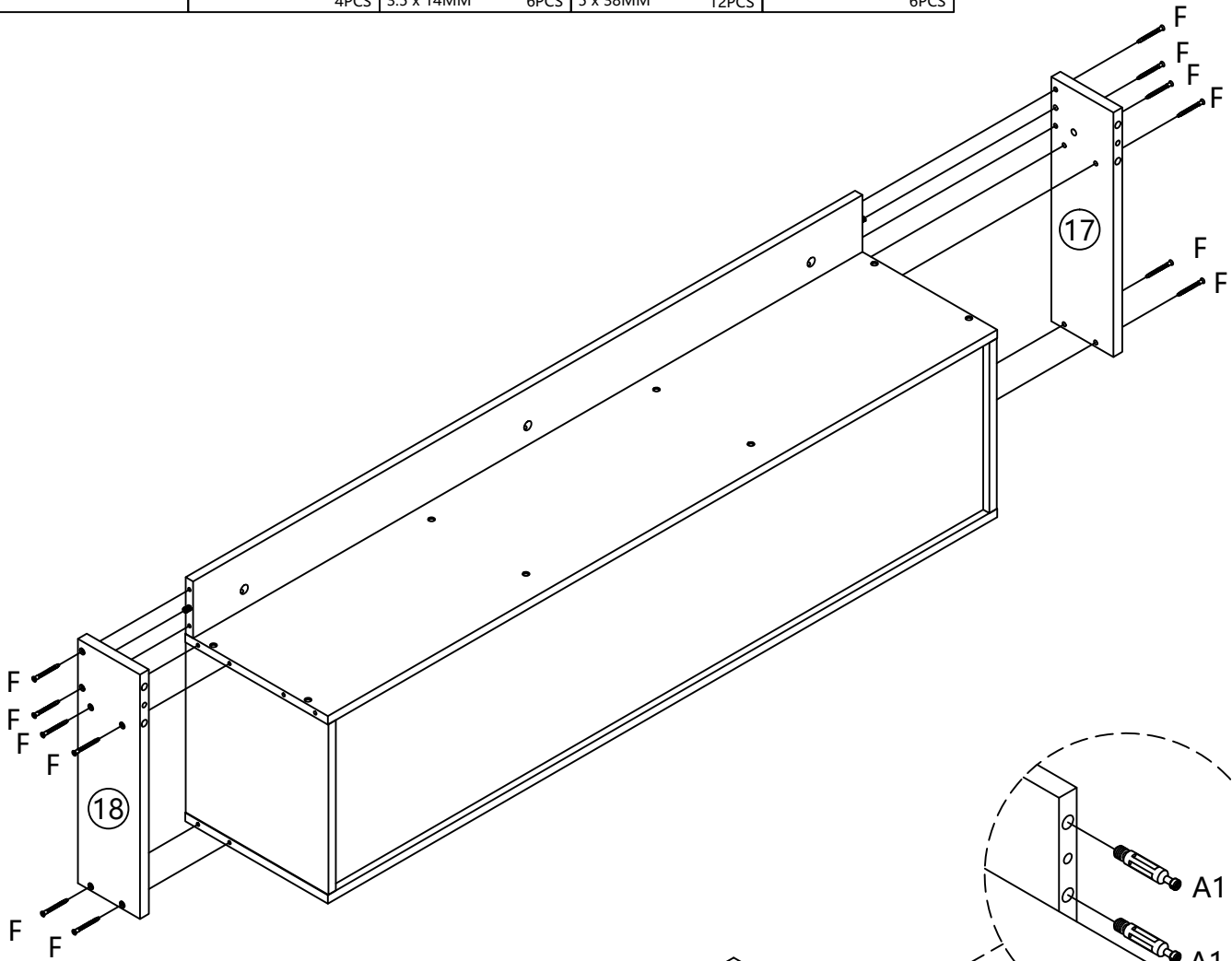

12

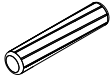
B

8 x 40MM

4PCS

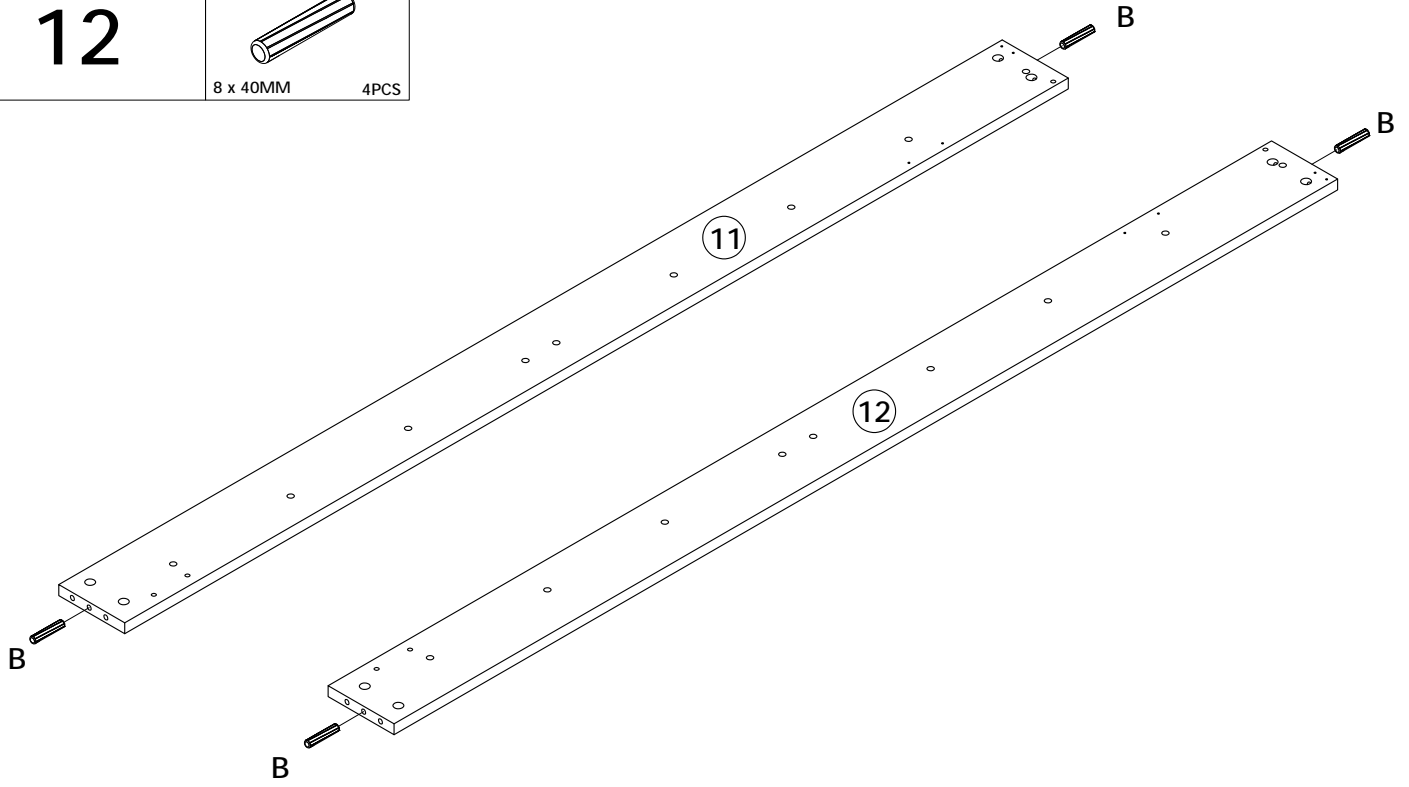

13

A2

4PCS

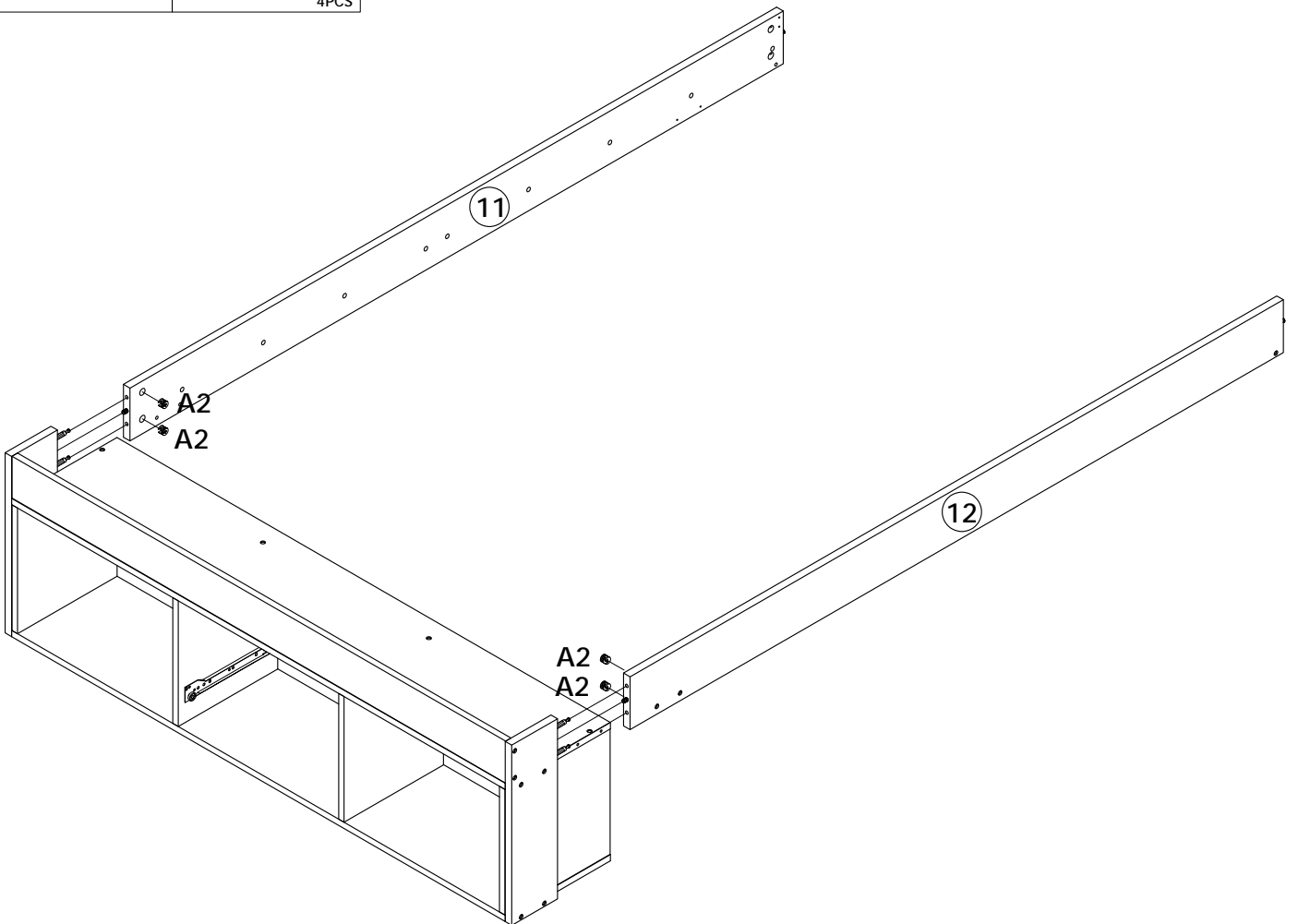

14

A2



4PCS

F

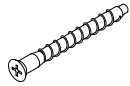

5 x 38MM

4PCS

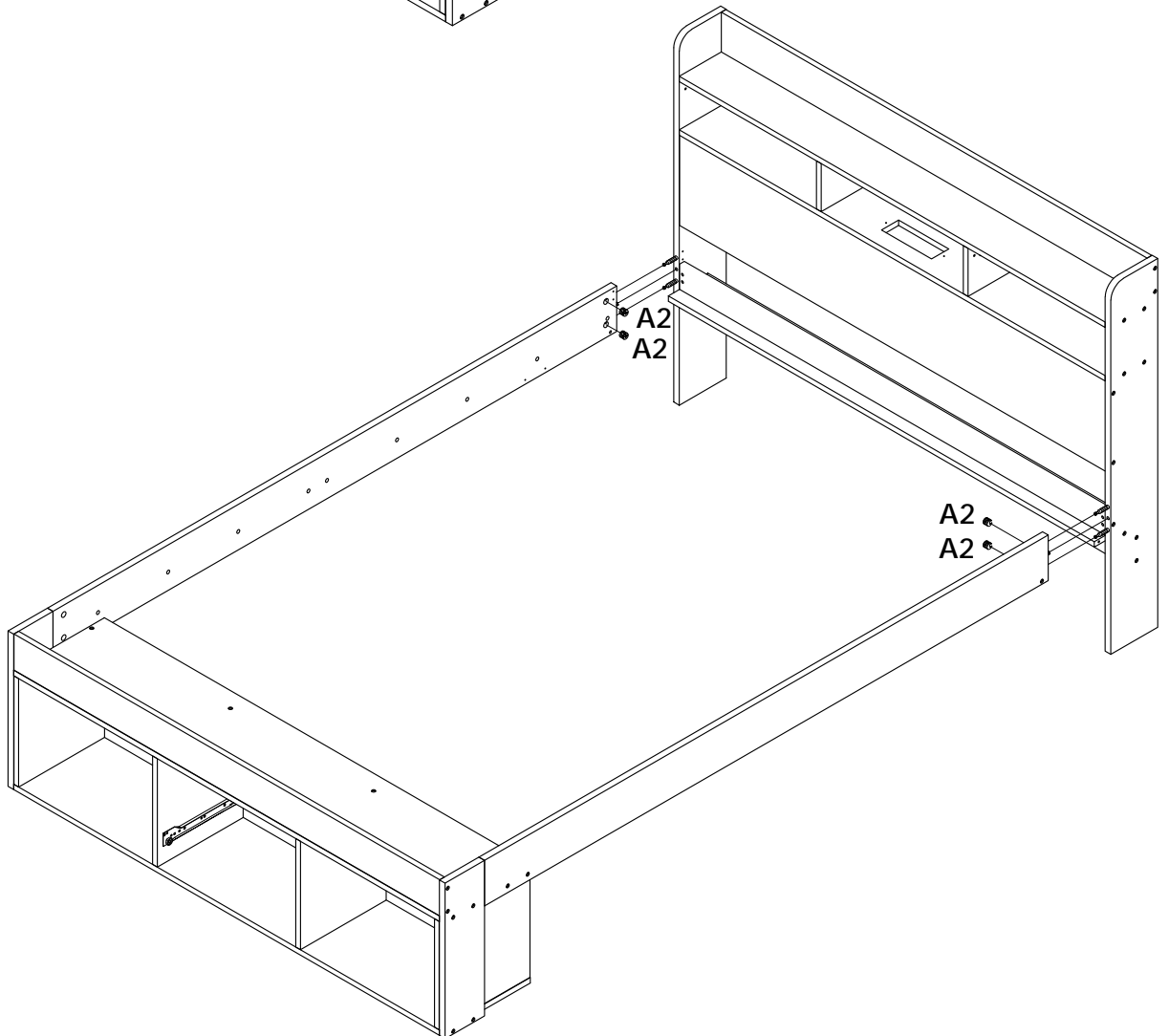
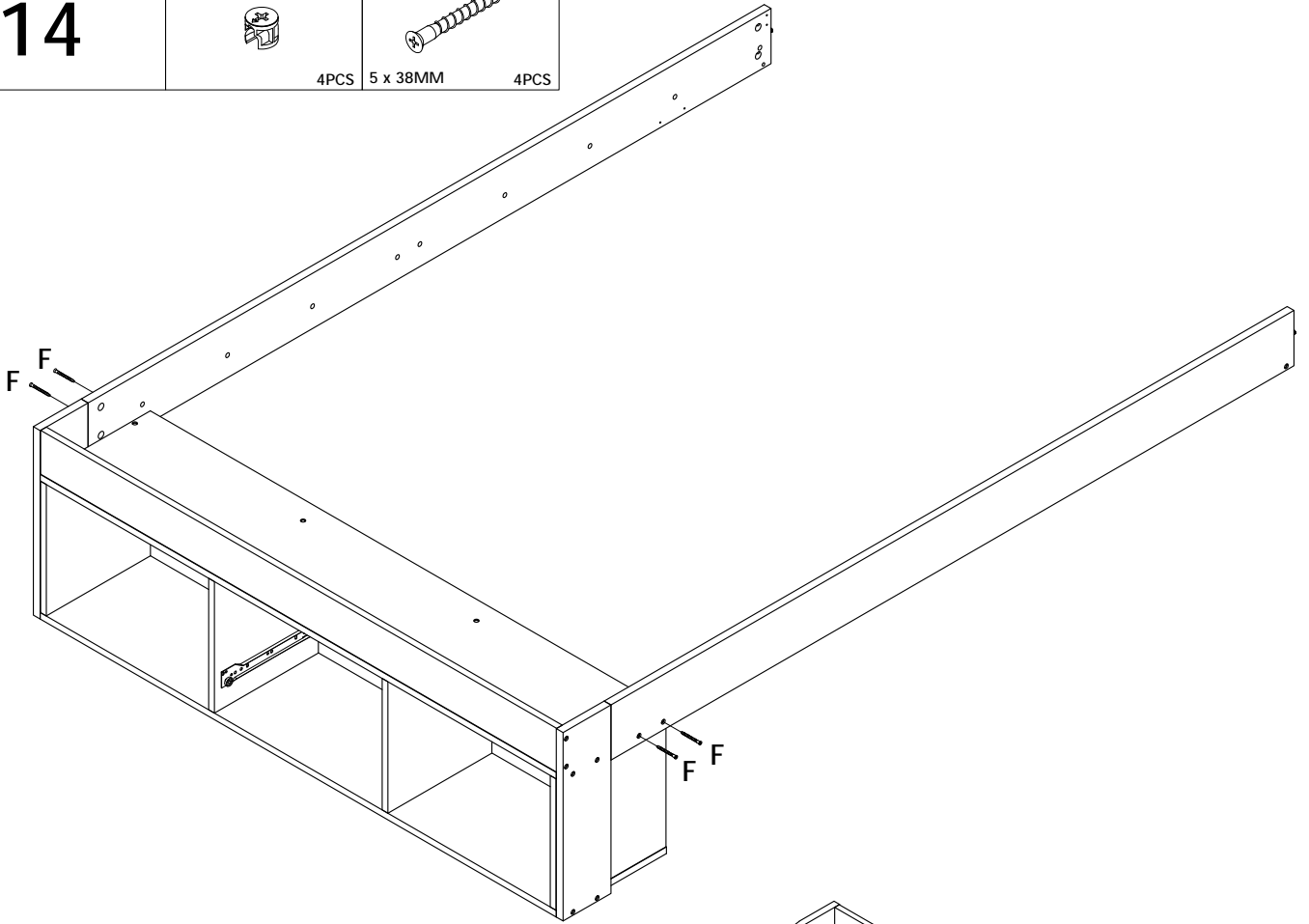

15

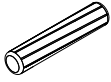
B

8 x 40MM

2PCS

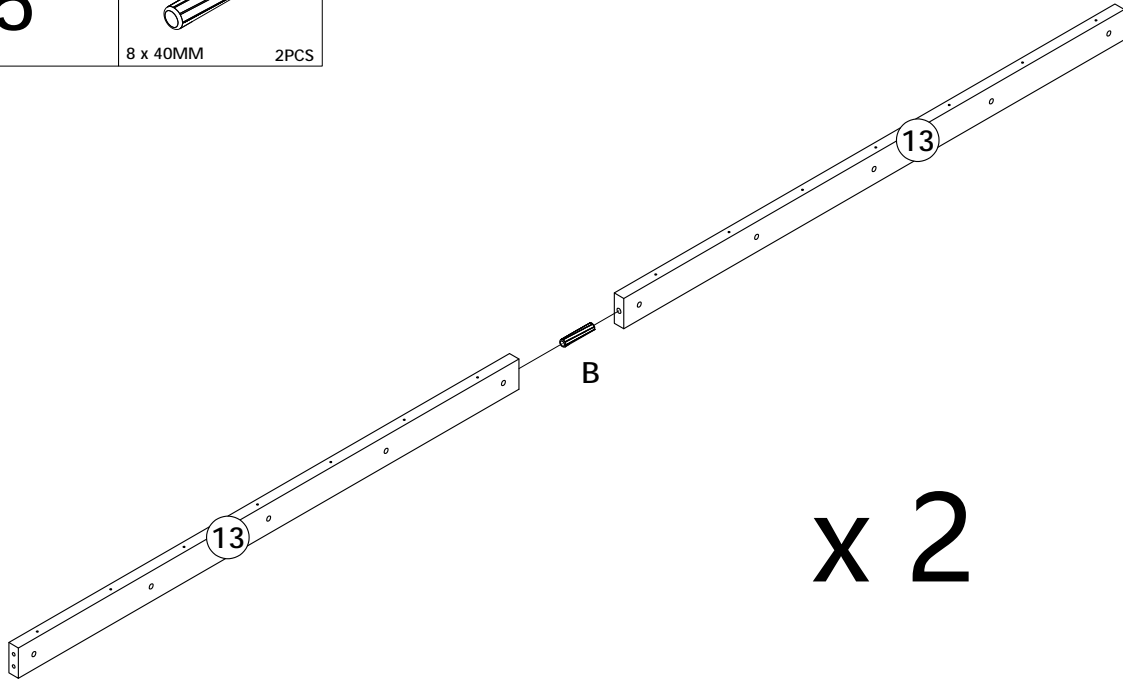

x 2

16

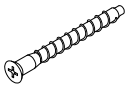
F

5 x 38MM

2PCS

J

6 x 30MM

20PCS

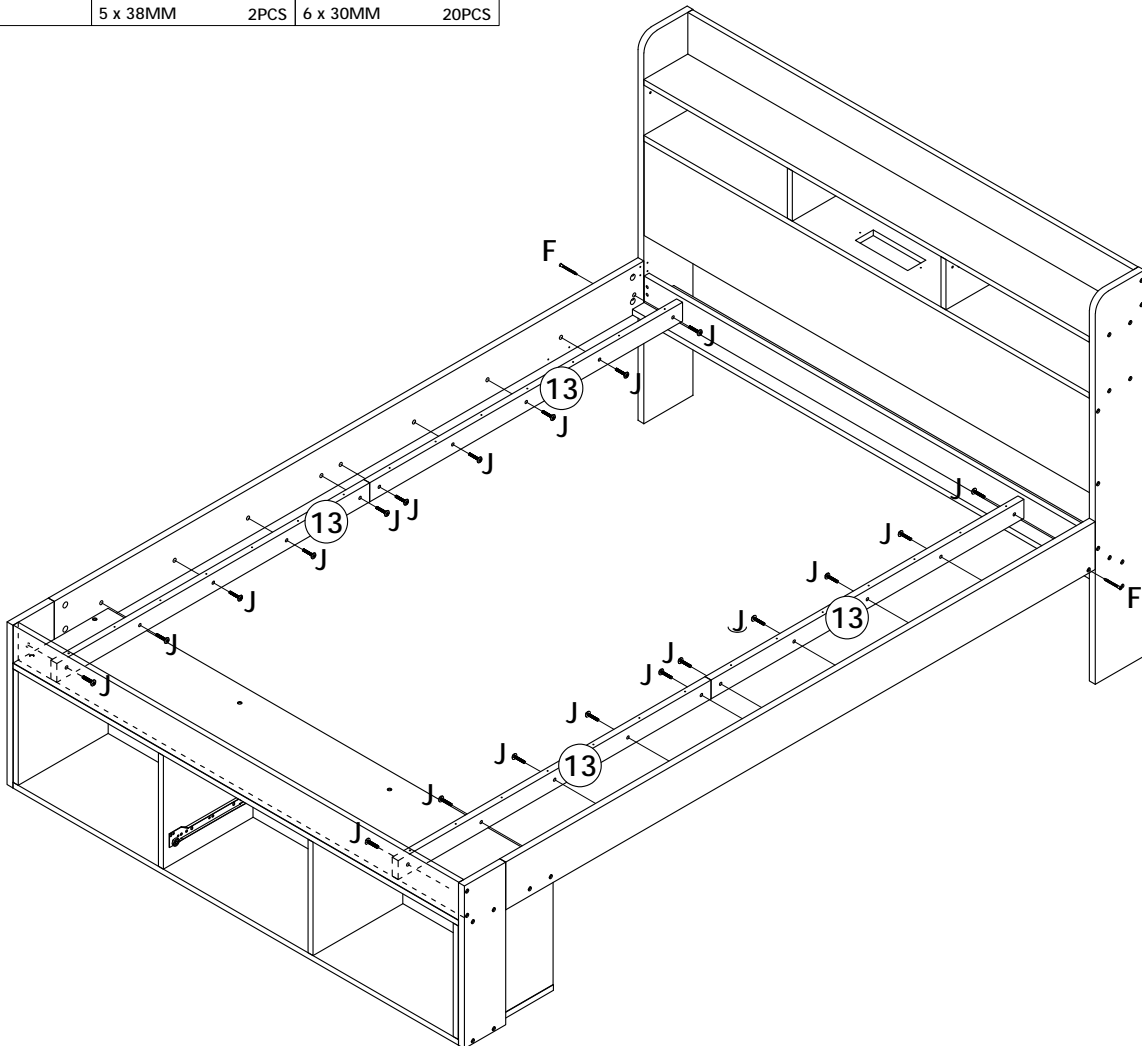

17

C

3.5 x 14MM

8PCS

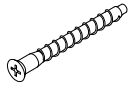
F

5 x 38MM

4PCS

Q

2PCS

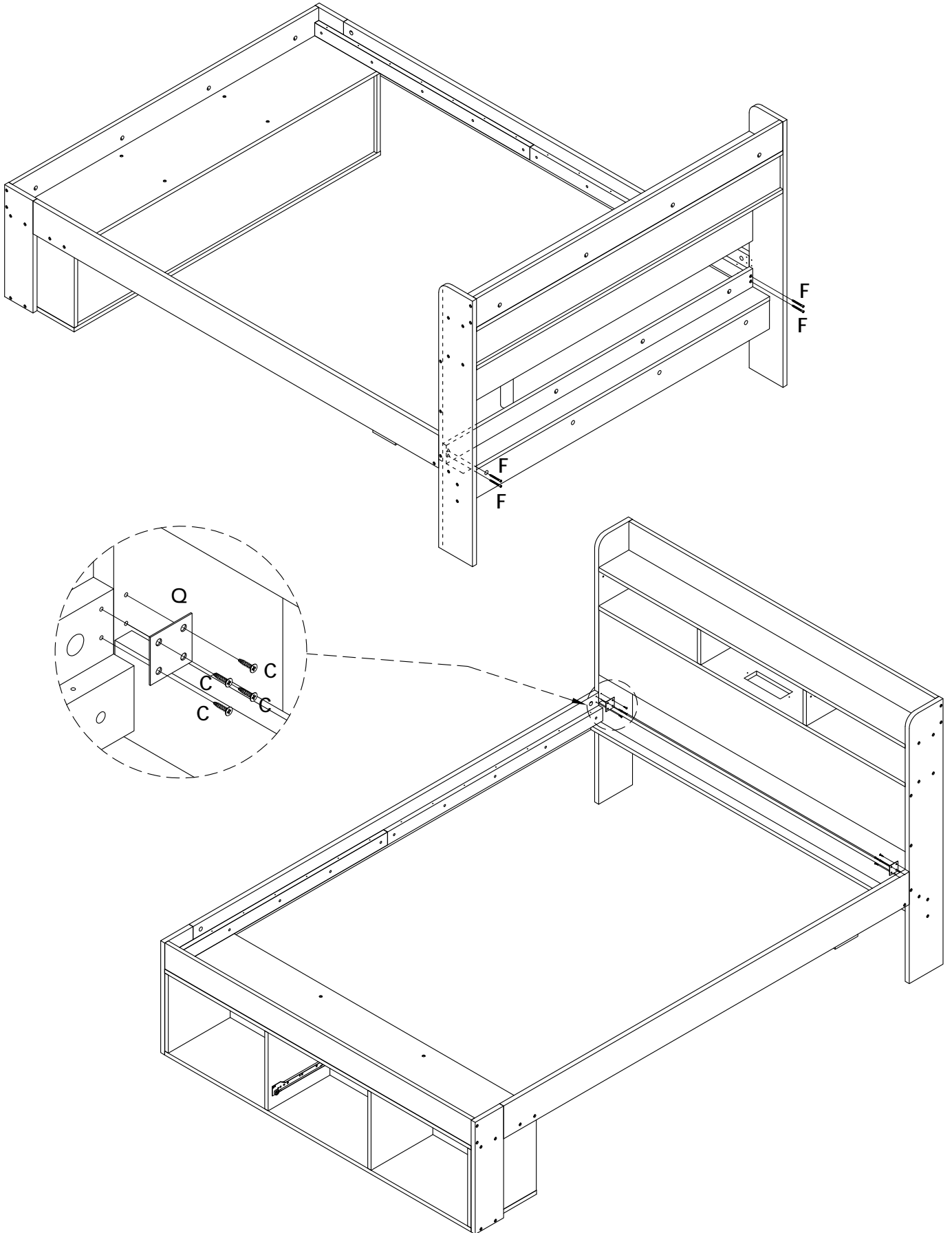

18

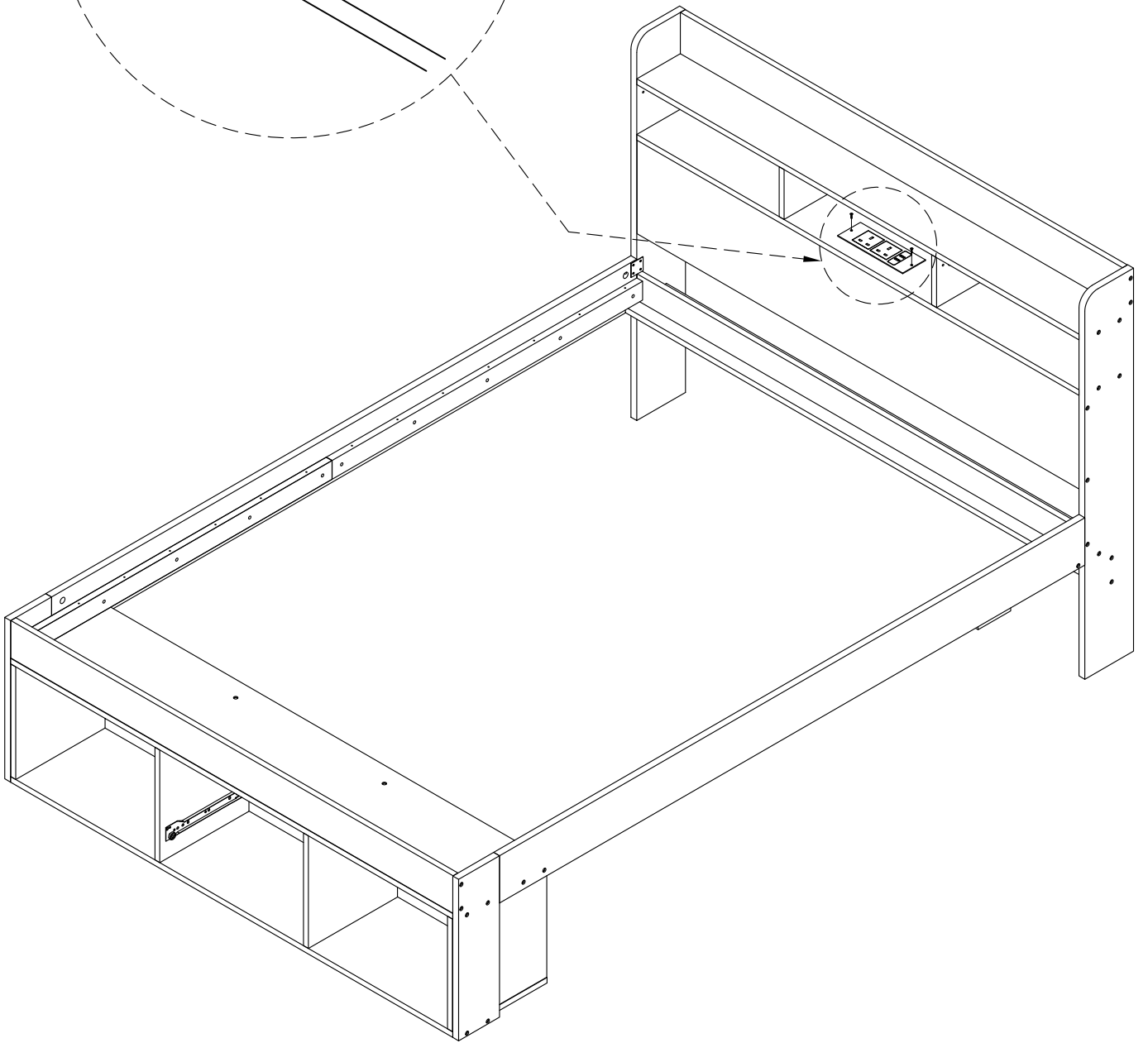
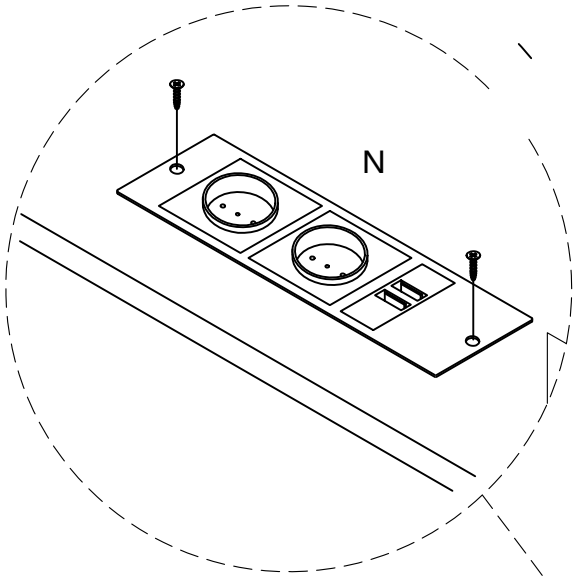
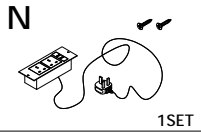

19

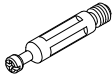
A1

8PCS

A2

8PCS

D

3.5 x 30MM

8PCS

x 2

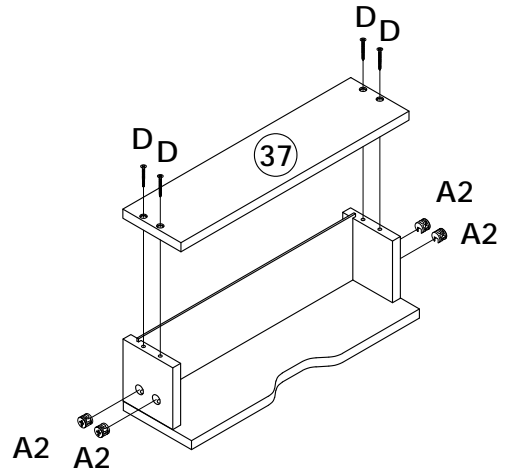
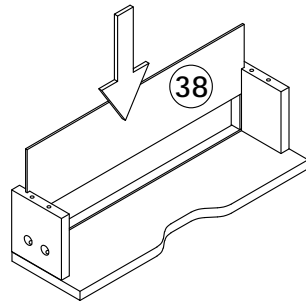
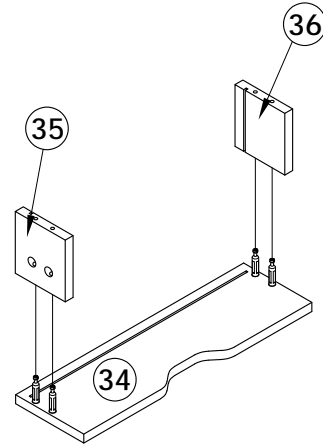
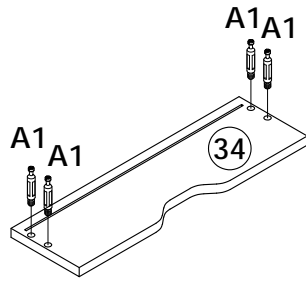

20

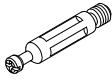
A1

4PCS

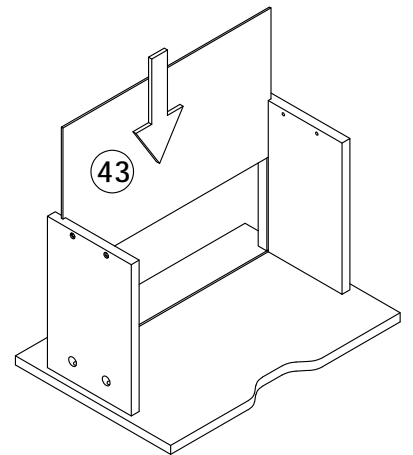
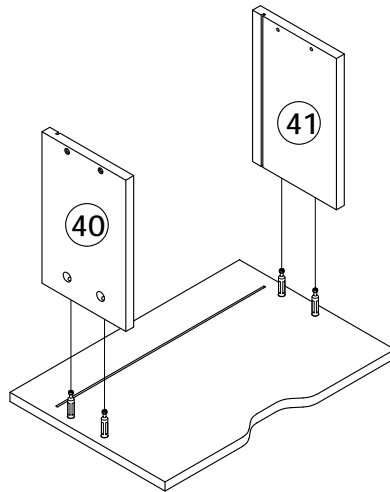
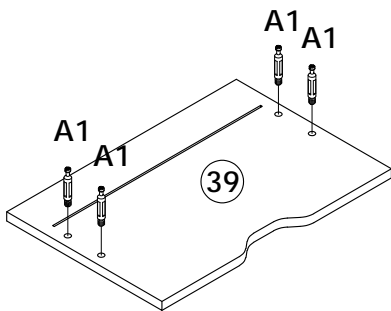

22

A2



4PCS

C



3.5 x 14MM

4PCS

D



3.5 x 30MM

4PCS

E(DL)



1PC

E(DR)

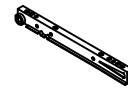

1PC

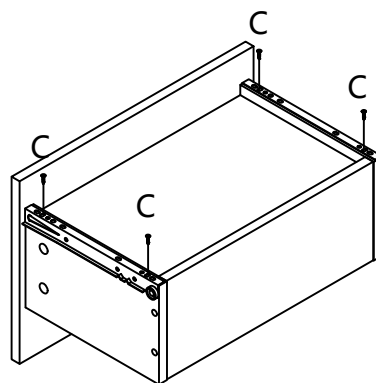
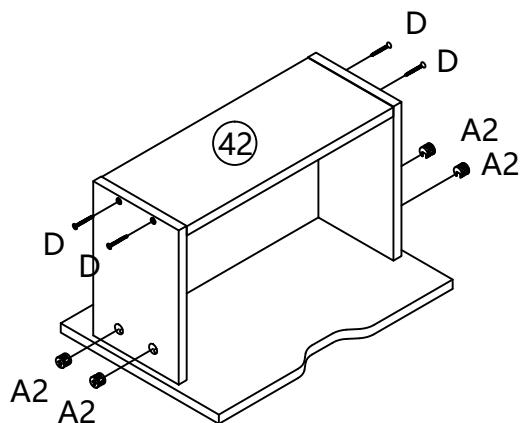

23

M



4PCS

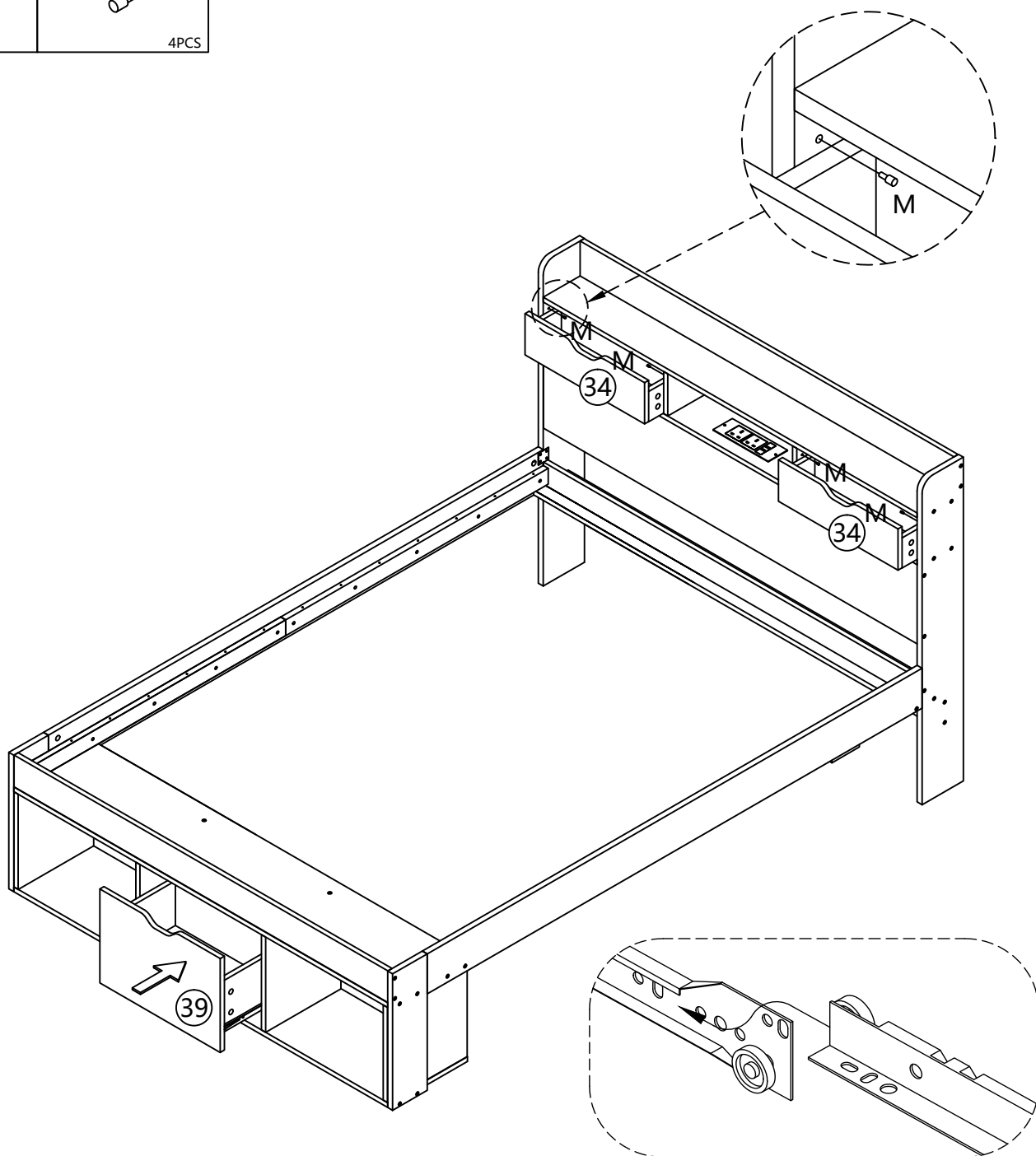

23

A1

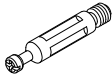

10PCS

R



6 x 30MM

6PCS

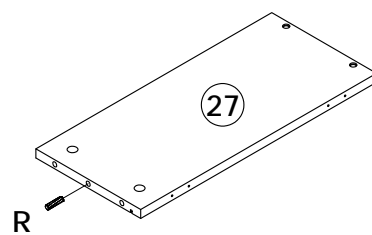
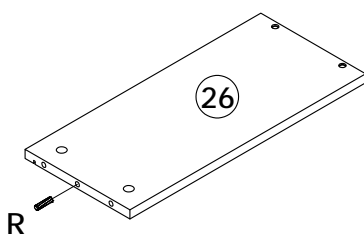
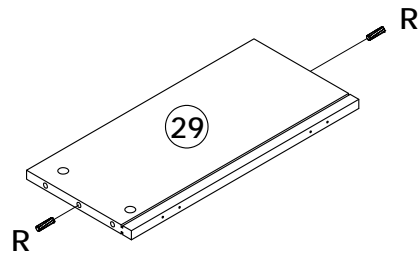
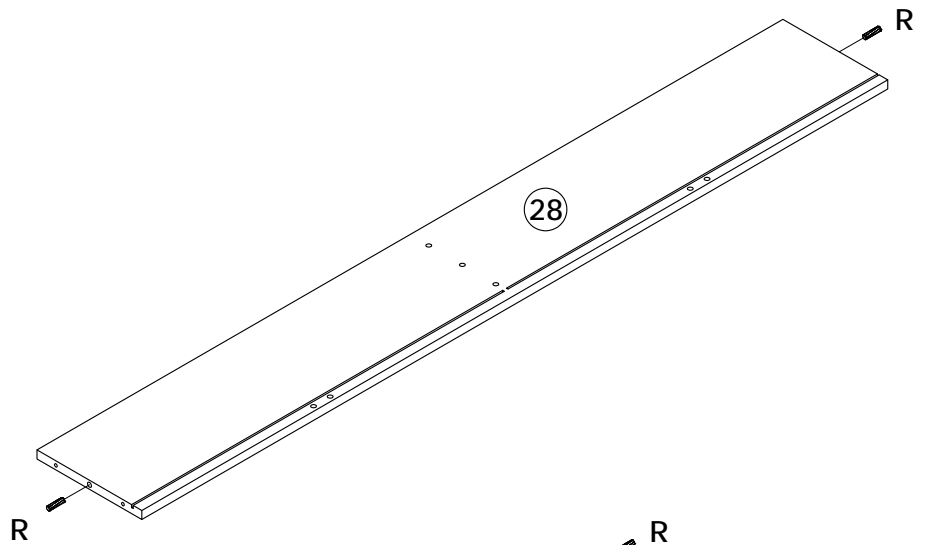
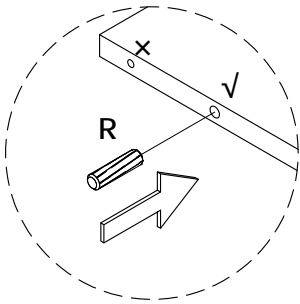
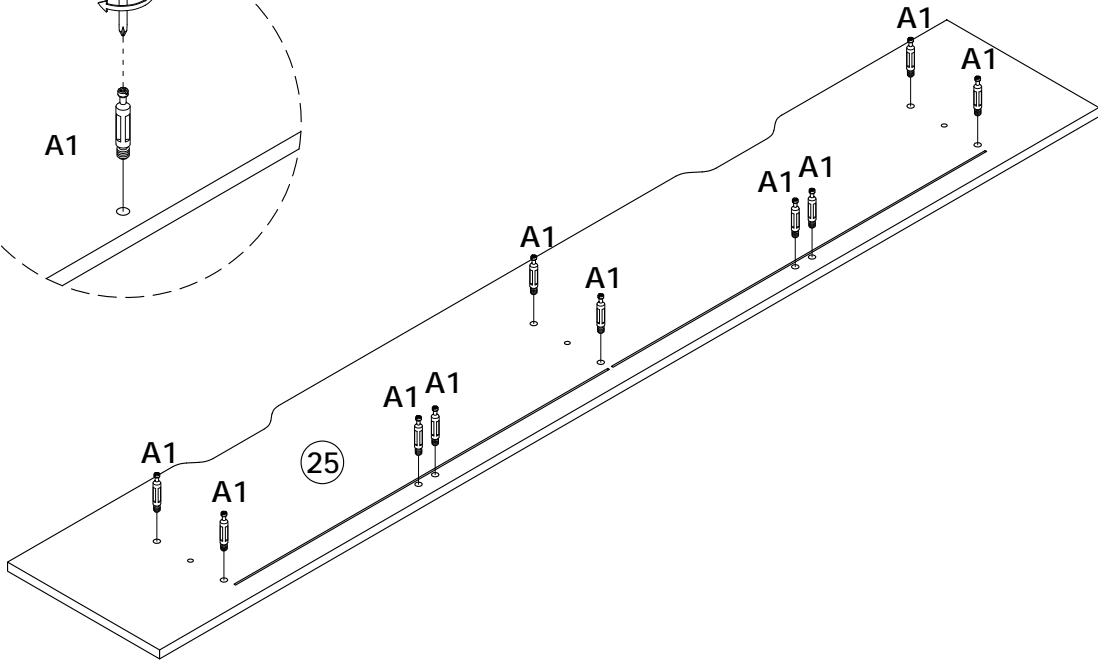
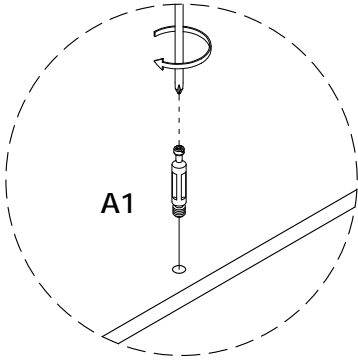

24

F

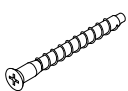

5 x 38MM

10PCS

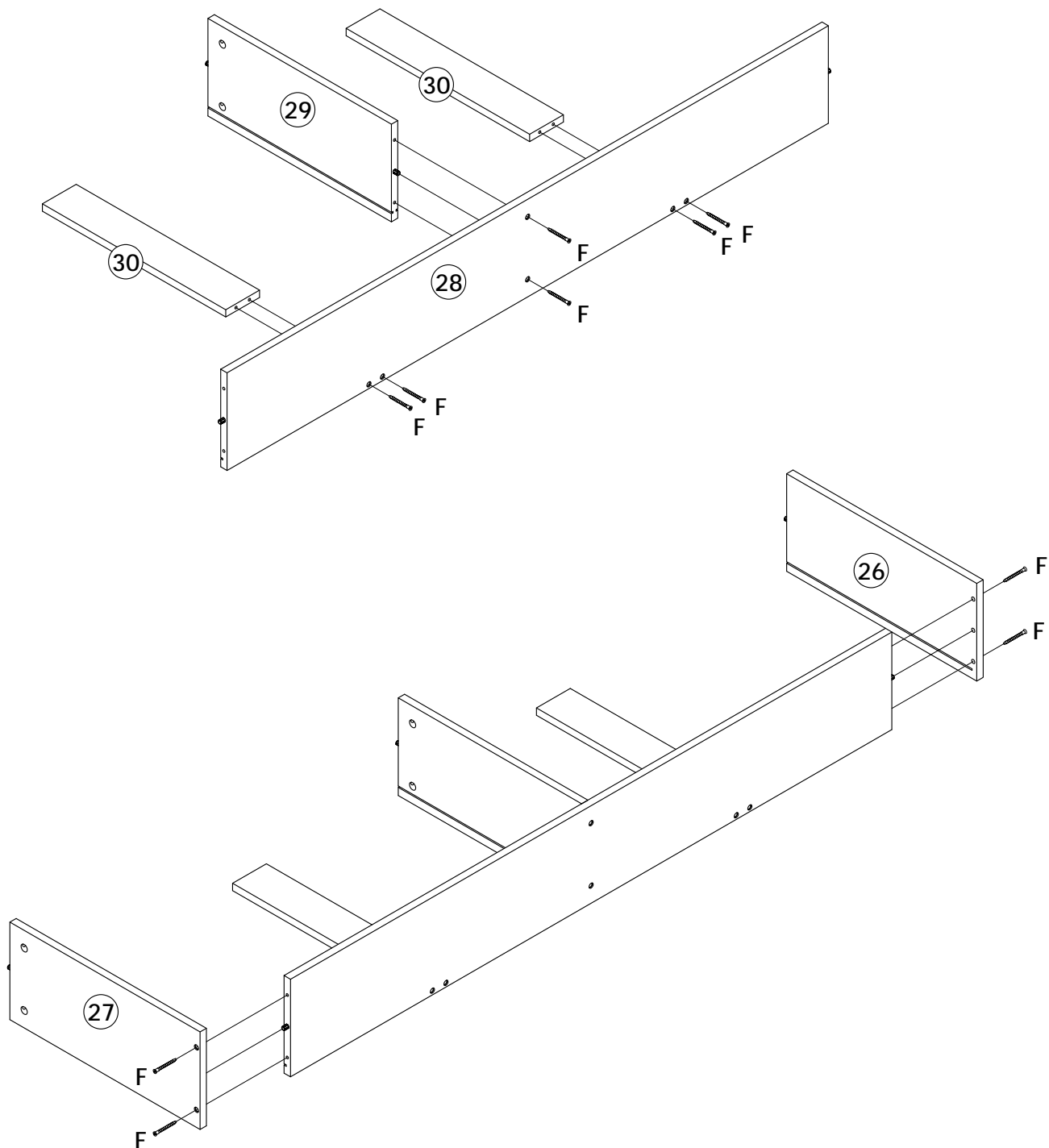

25

A2



10PCS

L

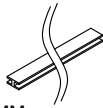

702MM

2PCS

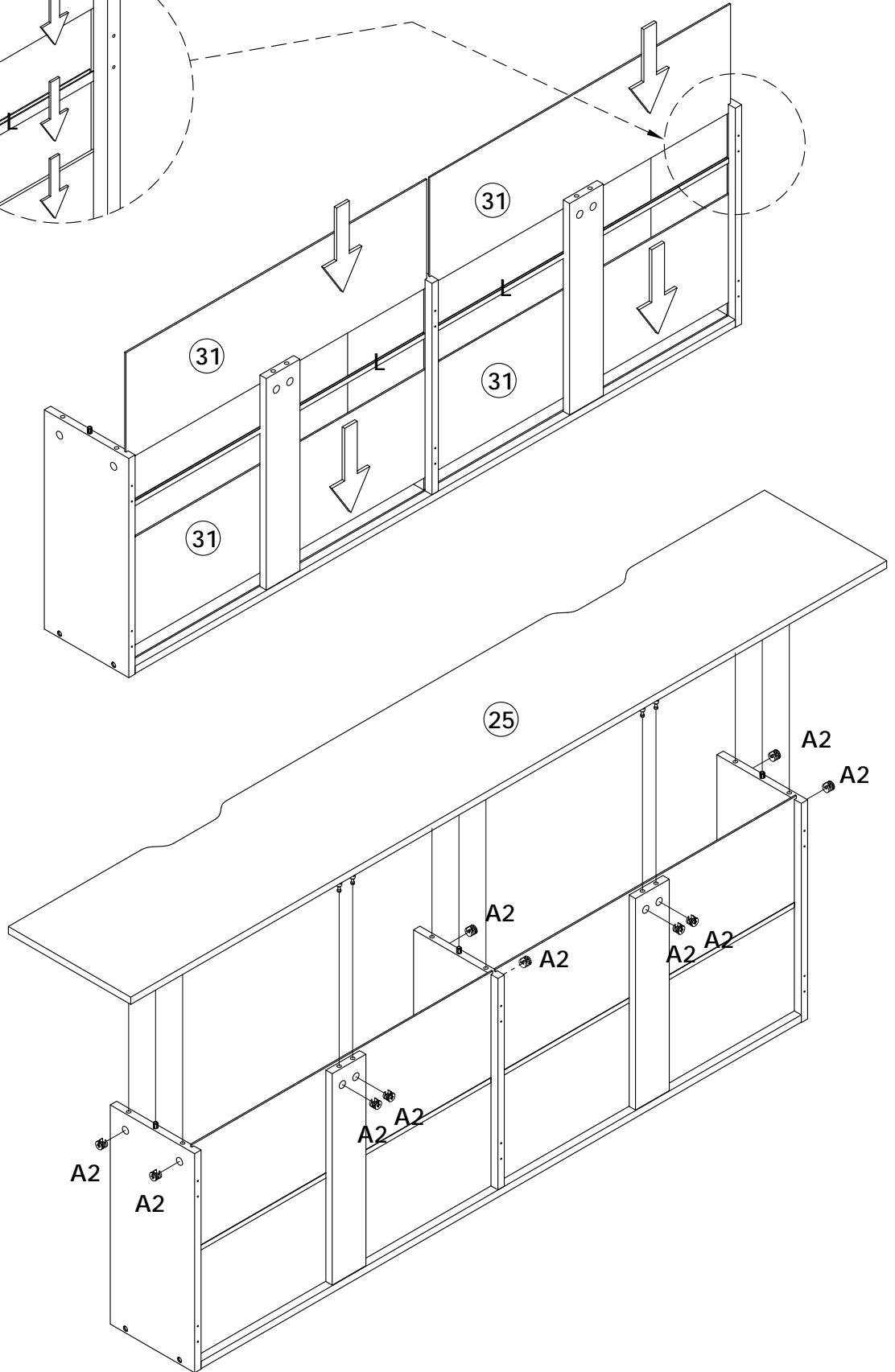
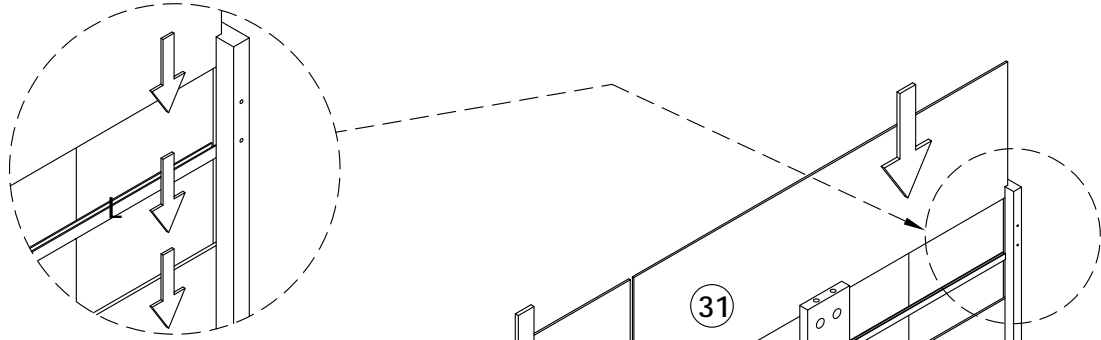

26

C



3.5 x 14MM

24PCS

H



6PCS

K



12PCS

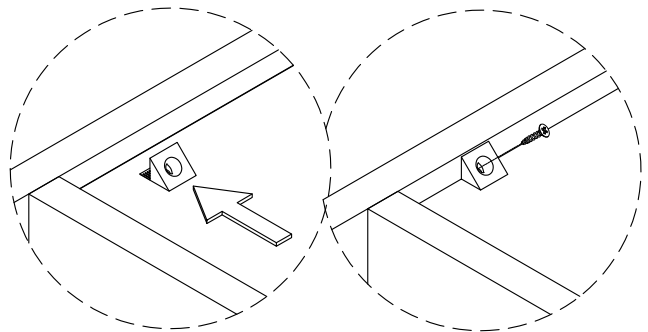
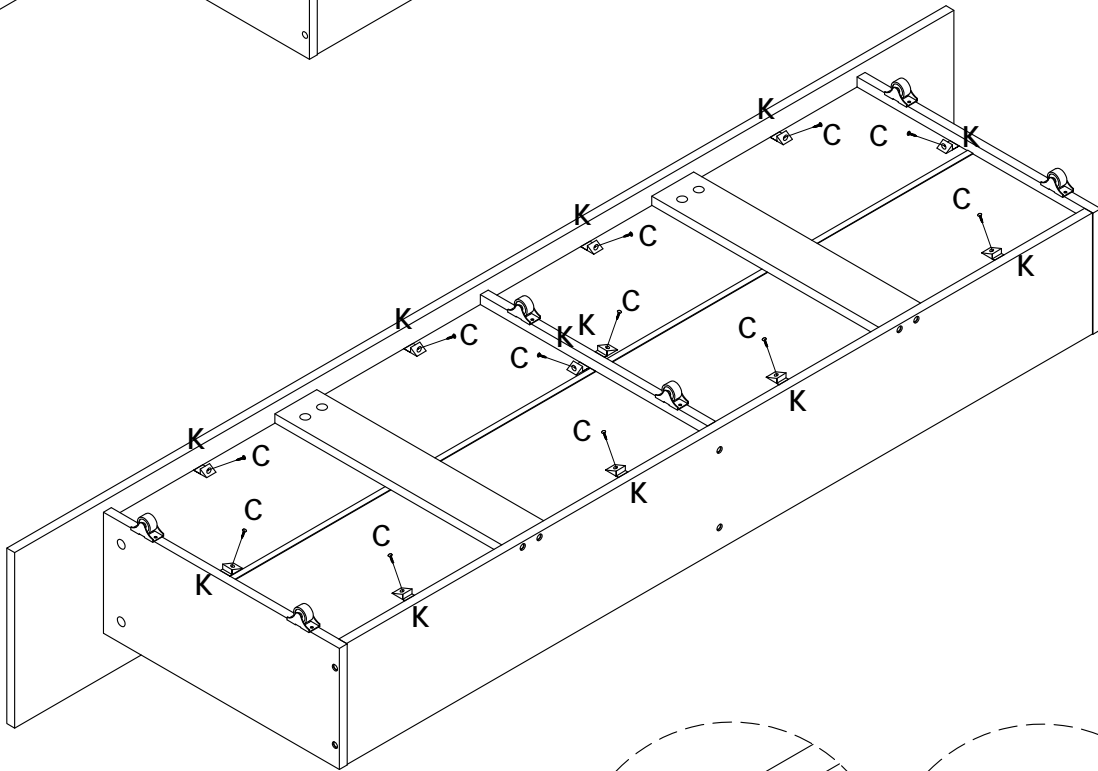
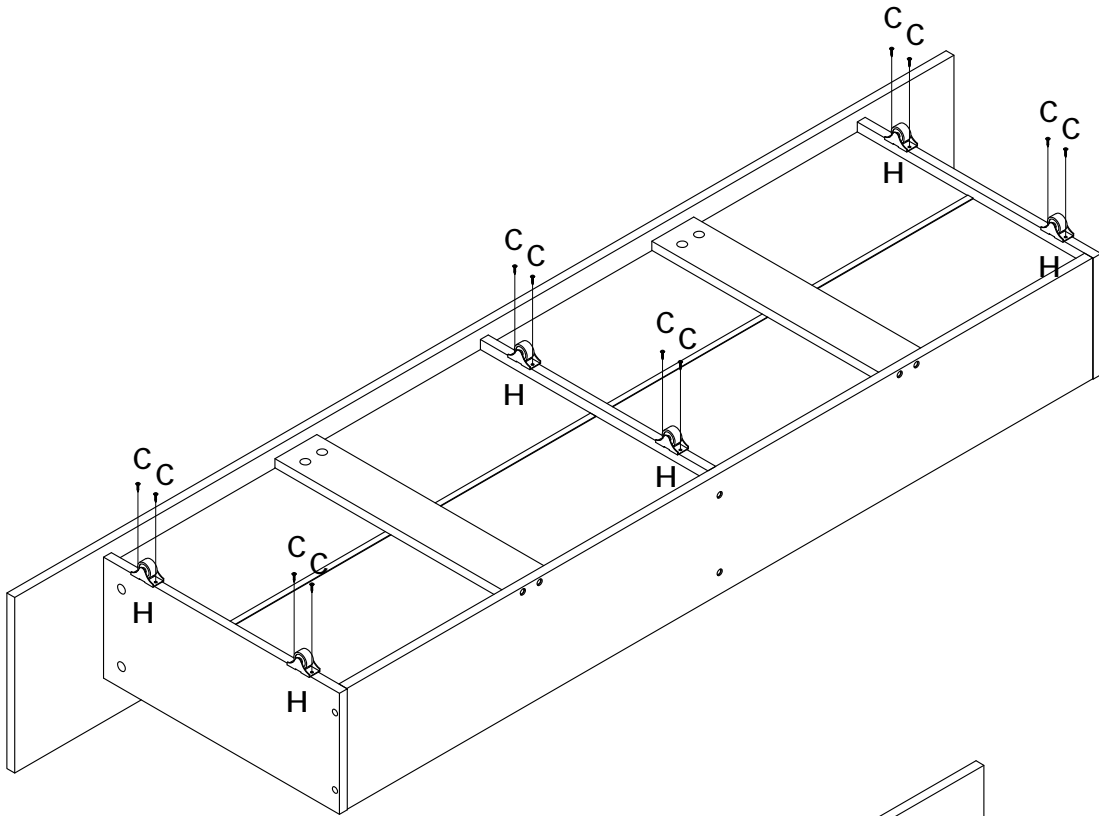

27

D



3.5 x 30MM

2PCS

OPTION 1

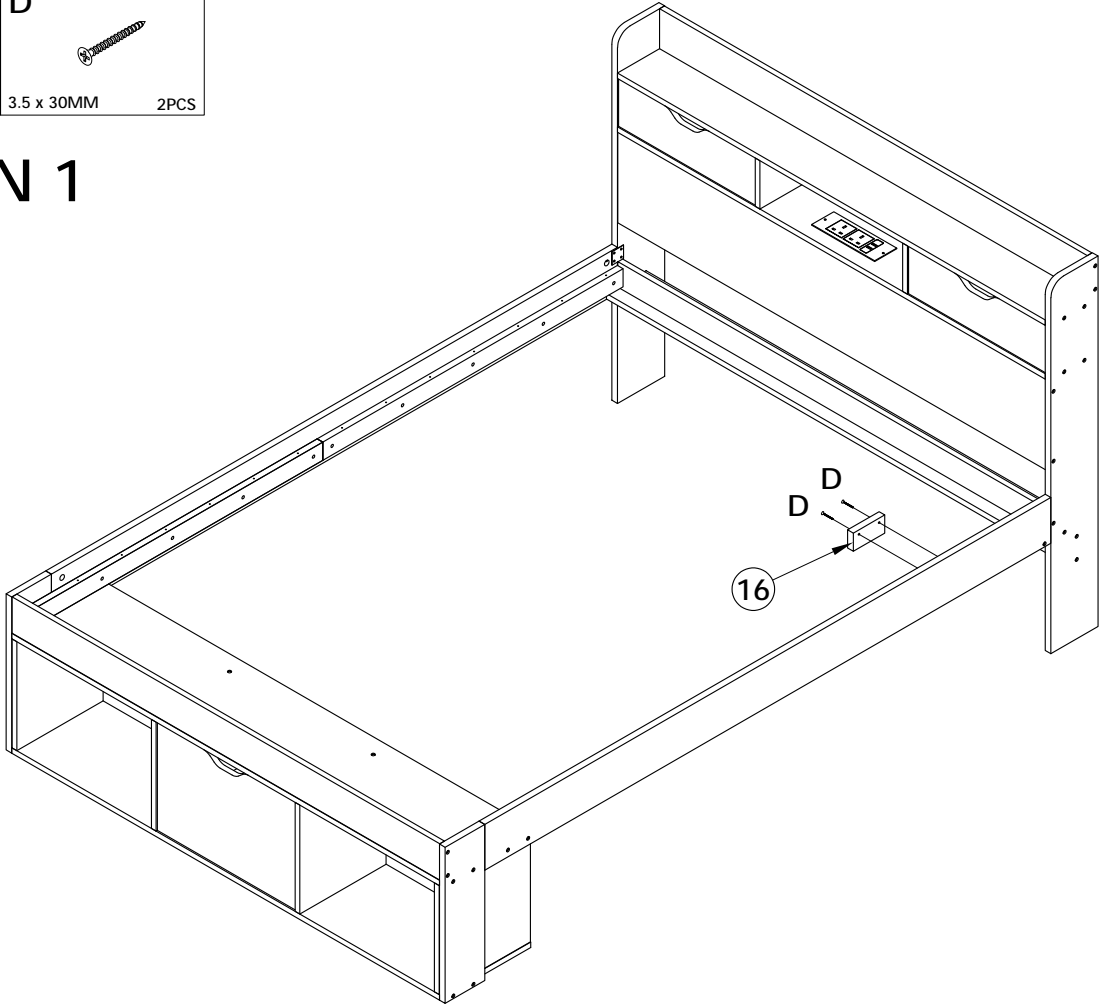

OPTION 2

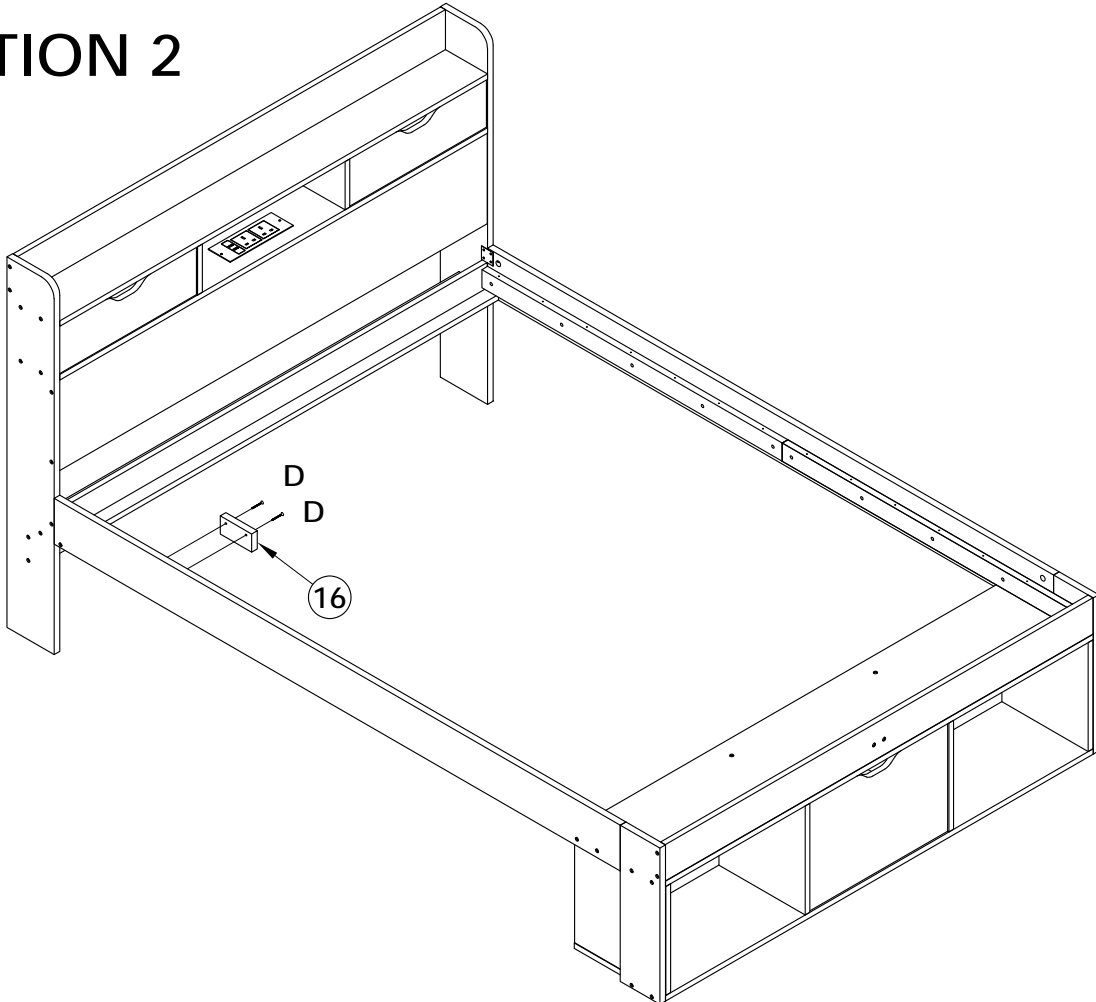

28

OPTION 1

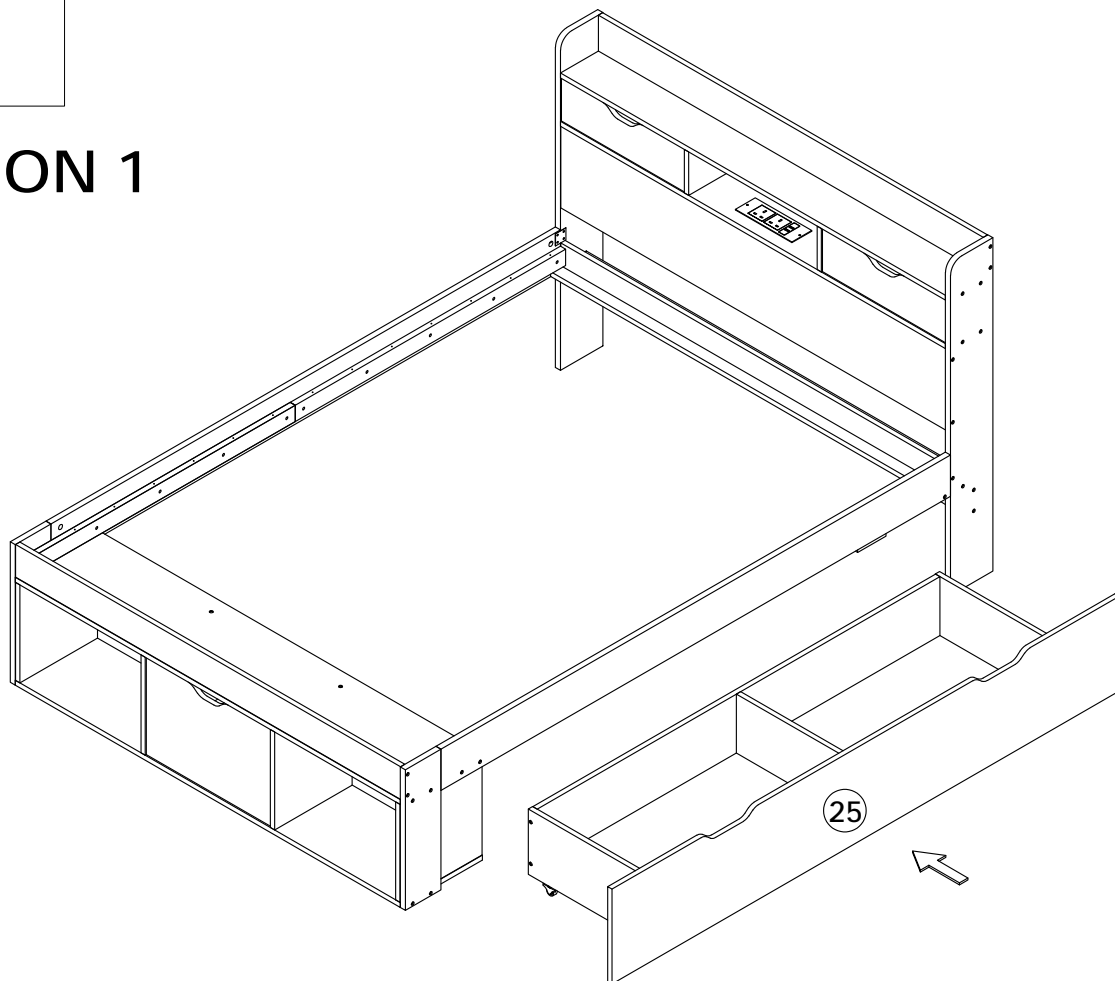

OPTION 2

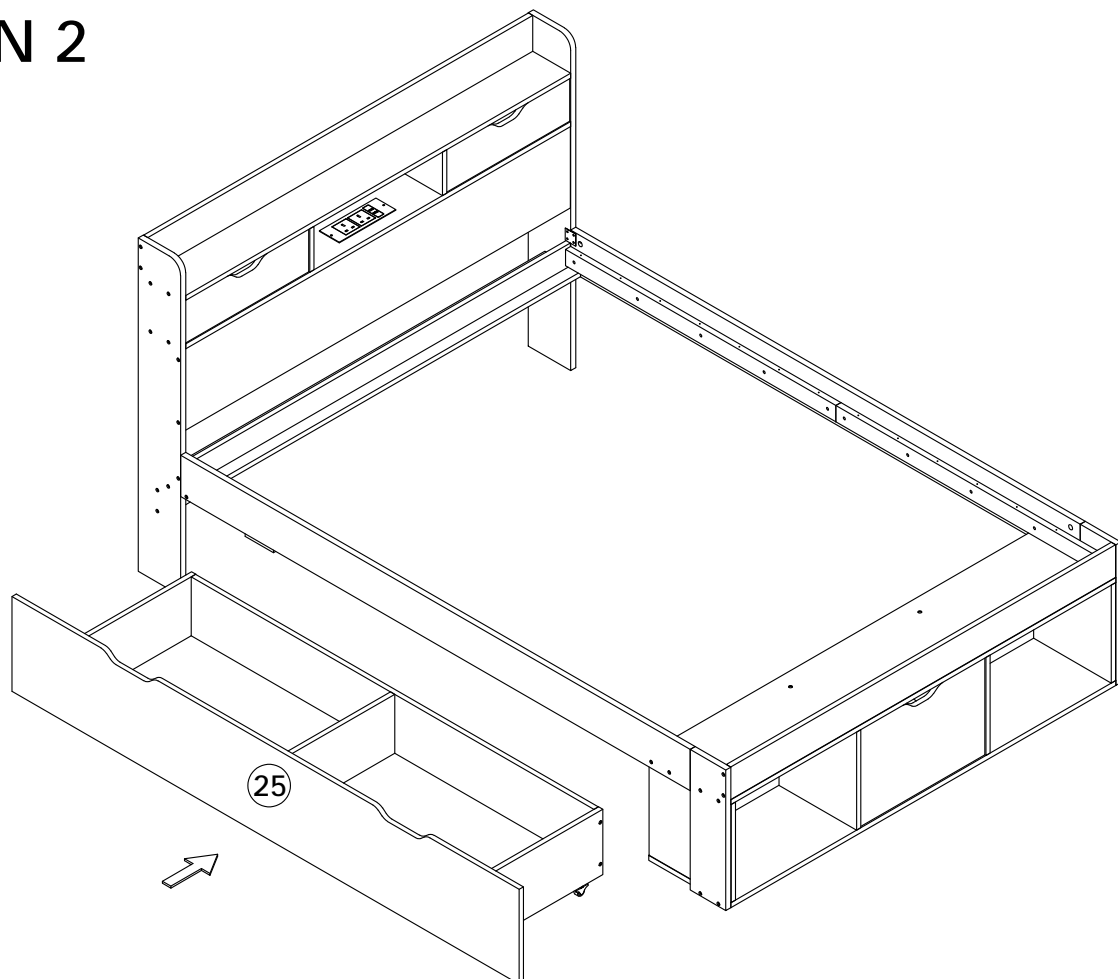

29

D



3.5 x 30MM

28PCS

OPTION 1

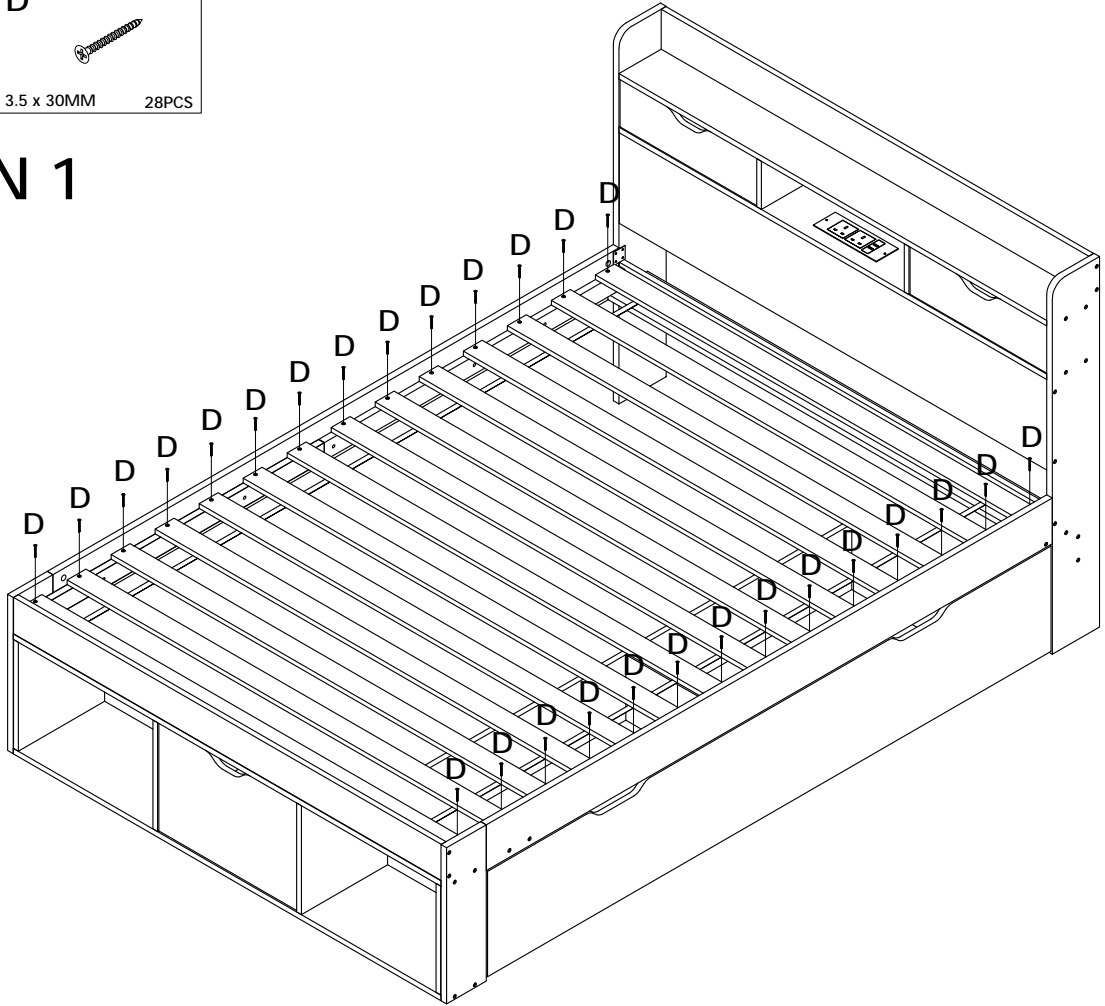

OPTION 2

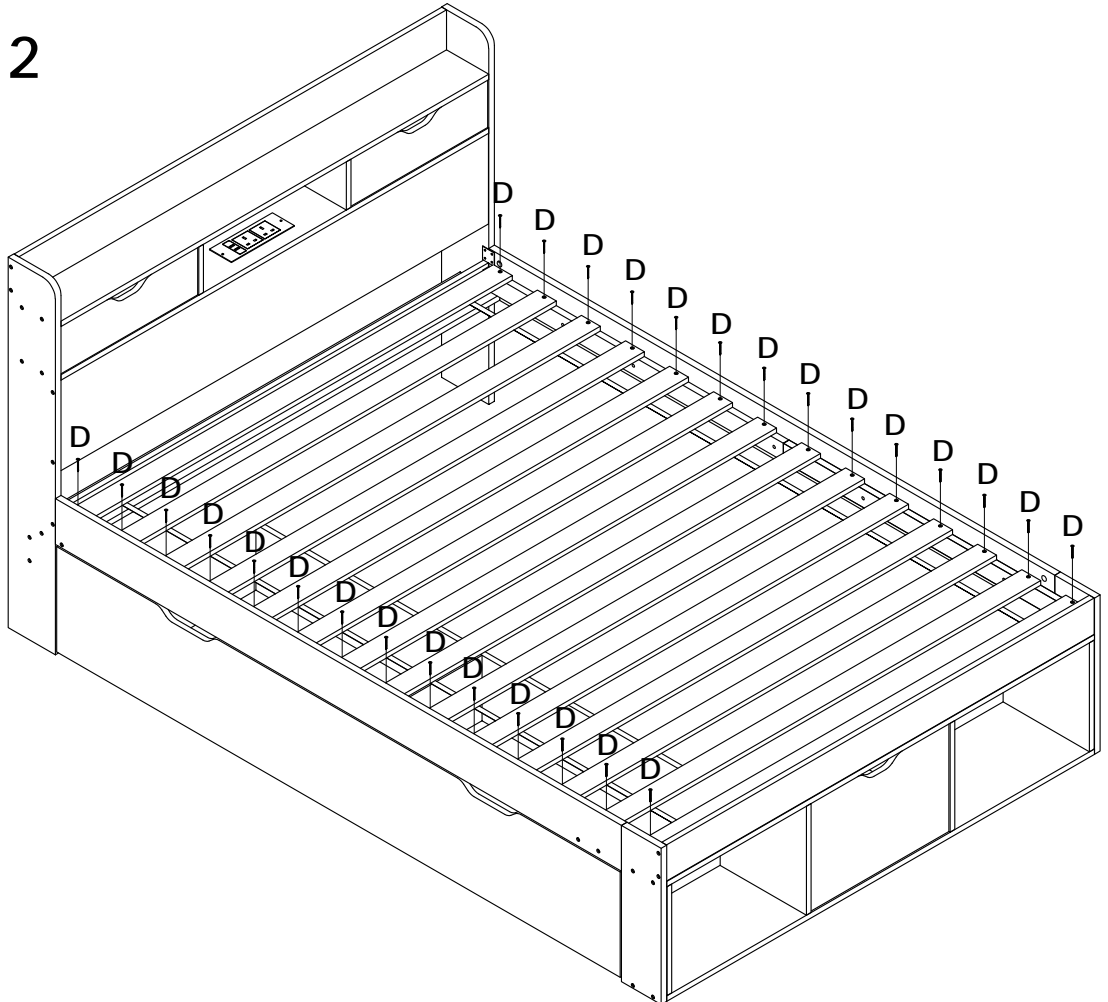

30

G



82PCS

OPTION 1

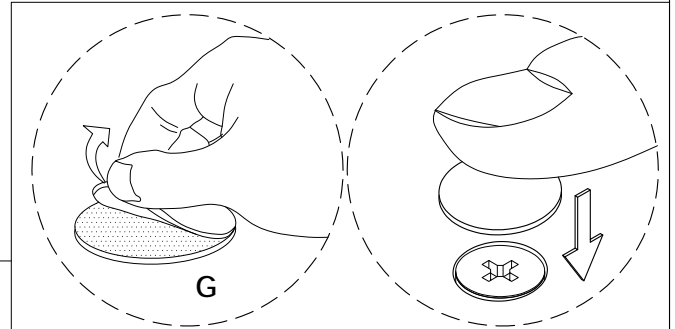
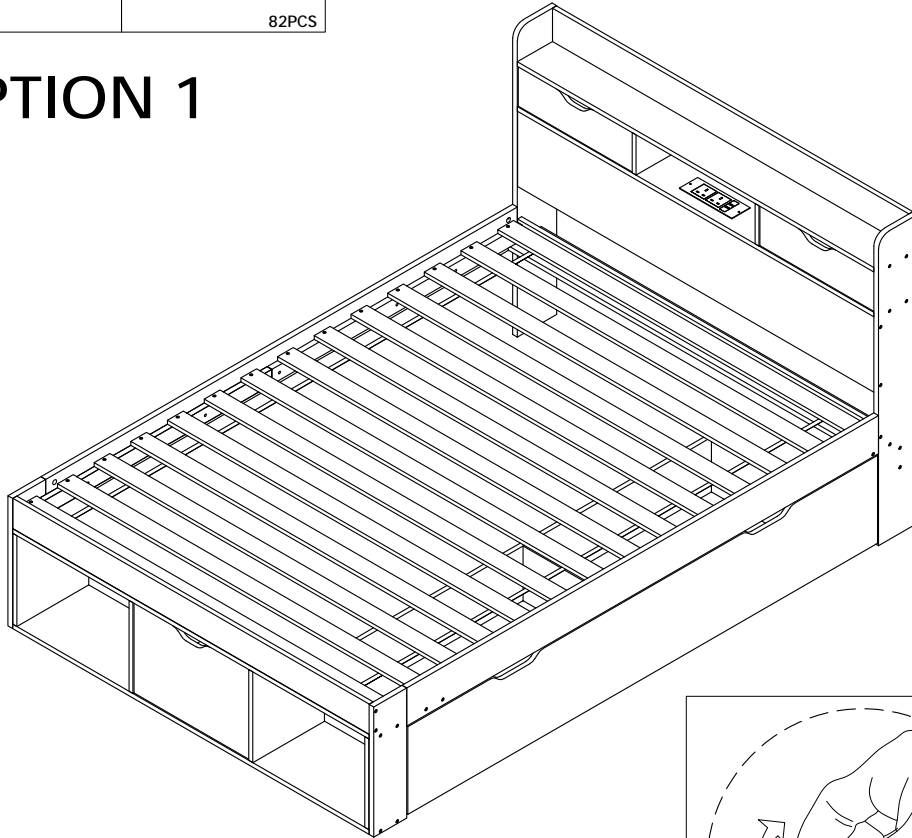

G

OPTION 2

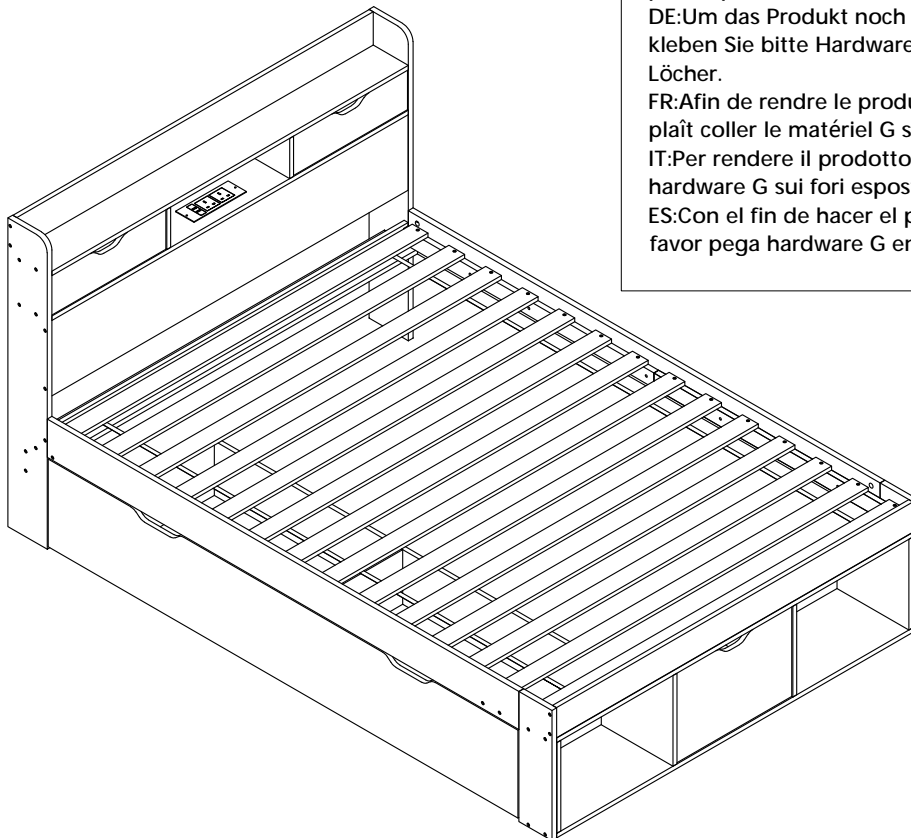

EN:In order to make the product more beautiful, please paste hardware G on the exposed holes.

DE:Um das Produkt noch schöner zu machen, kleben Sie bitte Hardware G auf die freiliegenden Löcher.

FR:Afin de rendre le produit plus beau, s' il vous plaît coller le matériel G sur les trous exposés.

IT:Per rendere il prodotto più bello, incollare l' hardware G sui fori esposti.

ES:Con el fin de hacer el producto más hermoso, por favor pega hardware G en los agujeros expuestos

Reference No. : WTN24N04082949E
Applicant : GuangdongZhangongElectricalTechnologyCo.,LTD
Address : 701,Building29,ZhifuGarden,XingtanTown,ShundeDistrict,FoshanCity
Manufacturer : Same as applicant
Address : Same as applicant
Product : Furniture socket
Model No. : ZG-JJ/10A/16A, details see attachment
Technical data : 250 Vac, 50 - 60 Hz, other details see attachment



Test Standards:

EN 55032:2015+A11:2020
EN 55035:2017+A11:2020
EN IEC 61000-3-2:2019+A1:2021
EN 61000-3-3:2013+A1:2019+A2:2021

The above product has been tested by us with the listed standards and found in compliance with the European Electromagnetic Compatibility Directive 2014/30/EU. It is possible to use CE marking to demonstrate the compliance with this EMC Directive.

EN 55032: Electromagnetic compatibility of multimedia equipment - Emission Requirements
EN 55035: Electromagnetic compatibility of multimedia equipment - Immunity requirements
EN IEC 61000-3-2: Electromagnetic compatibility (EMC) - Part 3-2: Limits - Limits for harmonic current emissions (equipment input current ≤ 16 A per phase)
EN 61000-3-3: Electromagnetic compatibility (EMC) -Part 3-3: Limits -Limitation of voltage changes, voltage fluctuations and flicker in public low-voltage supply systems, for equipment with rated current ≤ 16 A per phase and not subject to conditional connection

The referred test report(s) show that the product complies with standard(s) recognized as giving presumption of compliance with the essential requirements in the above mentioned EU Directive. Other relevant Directives have to be observed.

After preparation of the necessary technical documentation as well as the EU Declaration of Conformity, the CE marking as shown below can be affixed on the equipment under the sole responsibility of the manufacturer.



Manager: Jianzhong Mao
Date: 2024-05-06

The statement is based on a single evaluation of the sample of above mentioned product. It does not imply an assessment of the whole production.

Waltek Testing Group (Ningbo) Co., Ltd.

Hotline: 400-840-2288 E-mail: nb@waltek.com.cn
Http://www.waltek.com.cn



Attachment

Model list



Reference No: WTN24N04082949E

No.	Model	Rated Input	Max Output	Note
1.	ZG-PDUM0/12A/15A	250 Vac, 50 - 60 Hz, 16 A	2 * Type-A Output: Max. 5 Vdc, 2 A, AC Output: Max.16 A	With multiple socket-outlets, with USB output
2.	ZG-PDUG1/10A/16A			
3.	ZG-PDUG2/10A/16A			
4.	ZG-PDUG3/10A/16A			
5.	ZG-PDU J00/10A/16A			
6.	ZG-PDUF/10A/16A			
7.	ZG-PDUW1/10A/16A			
8.	ZG-PDUW2/10A/16A			
9.	ZG-PDUB/10A/16A			
10.	ZG-PDUC3/10A/15A			
11.	ZG-PDUC9/10A/15A			
12.	ZG-PDUA/10A/15A			
13.	ZG-PDUY/10A/15A			
14.	ZG-JJ/12A/15A			
15.	ZG-HG/12A/15A			
16.	ZG-ZJ/12A/15A			
17.	ZG-SJ/12A/15A			
18.	ZG-DQ/12A/15A			
19.	ZG-PC/12A/15A			
20.	ZG-PDU00/10A/16A			
21.	ZG-JJ/10A/16A			

