

Installationsanleitung Installation Instruction Instructions d'installation

N623P250219/N623P250220

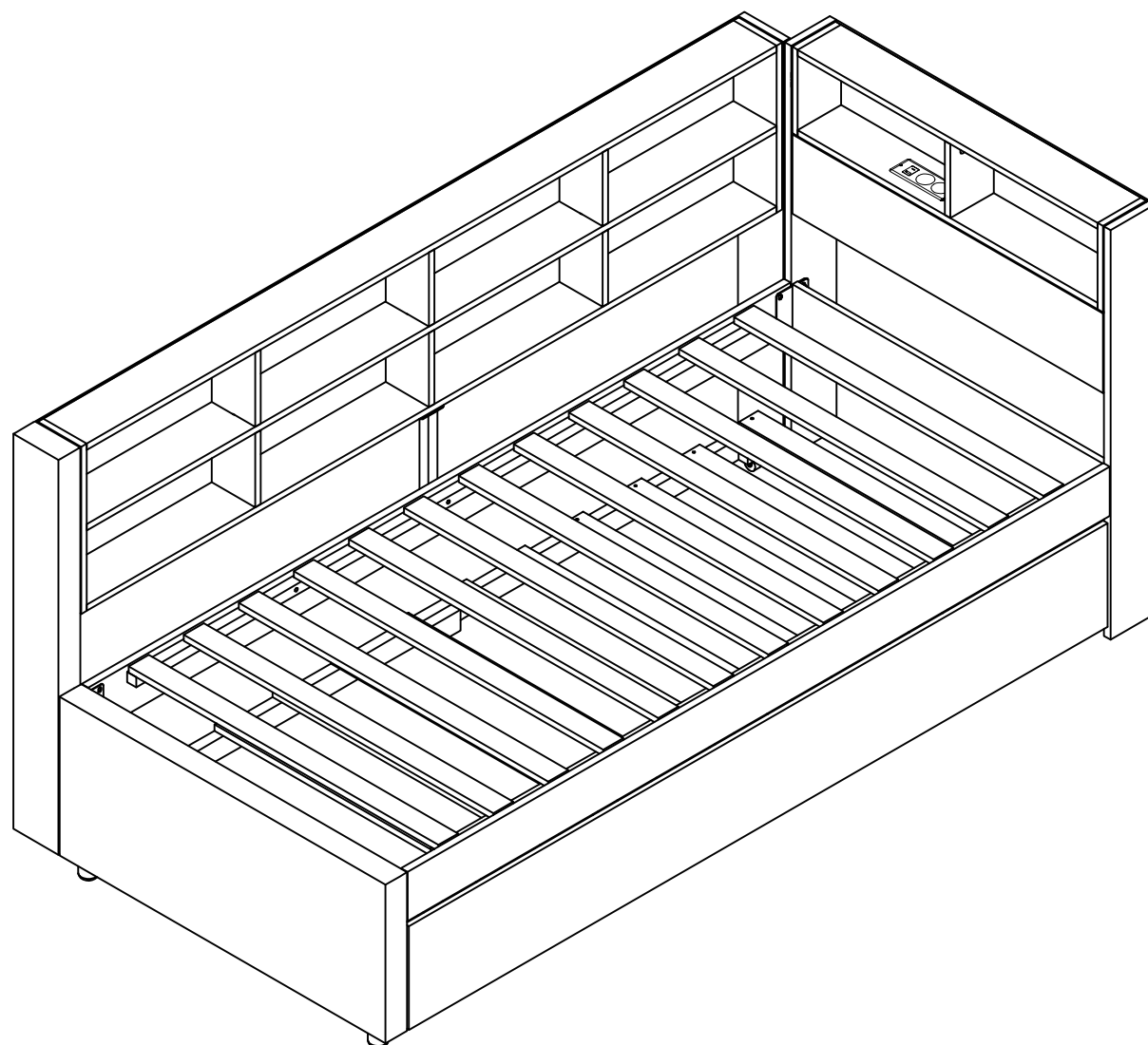

V4.0

DE: Unser Produkt wird Ihnen in 2 Paketen geliefert. Die Lieferzeiten dieser 2 Pakete können abweichen, bitte haben Sie etwas Geduld und vielen Dank für Ihr Verständnis.

UK: Our product will be delivered to you in 2 packages. The delivery times of these 2 packages may differ, please be patient and thank you for your understanding.

FR: Notre produit vous sera livré en 2 colis. Les délais de livraison de ces 2 colis peuvent différer, soyez patient et merci pour votre compréhension.

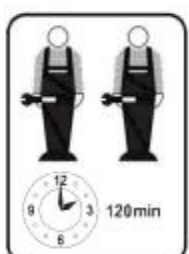

DE:Vor dem Einbau die Schrauben in die Löcher stecken und festziehen, aber nicht bis 100%, 70% bis 80% anziehen reicht aus. Schließlich, nachdem alle Schrauben installiert sind, ziehen Sie alle Schrauben auf 100%.Wenn Sie auf diese Probleme stoßen, wie z. B. Fehlausrichtung der Löcher oder Unfähigkeit, bestimmte Teile zu installieren, überprüfen Sie bitte, ob die Schrauben korrekt verwendet werden und passen Sie die Dichtigkeit der Schrauben an.

UK:Before installation, insert the screws into the holes and tighten them, but do not tighten them to 100%, 70% to 80% is sufficient. Finally, after all screws are installed, tighten all screws to 100%.If you encounter these issues, such as if the holes cannot be aligned or some parts cannot be installed, please check if the screws are used correctly and adjust the tightness of the screws.

FR:Insérer la vis dans le trou avant la fin de l'assemblage, serrer la vis, mais ne pas serrer à 100%, 70% ~ 80% est correct. Enfin, une fois que toutes les vis sont bien serrées, toutes les vis sont serrées à 100%.Si vous rencontrez ces problèmes, par exemple si les trous ne sont pas alignés ou si certaines pièces ne peuvent pas être montées, vérifiez que les vis sont utilisées correctement et Ajustez leur serrage.

English

IMPORTANT ! KEEP FOR FUTURE REFERENCE : READ CAREFULLY

- To be assembled by an adult. Assembly must be checked by an adult before use
- WARNING ! Keep all screws, small parts and plastic bags out of the reach of children
- Properly identify all parts before assembling
- Never use your item if any of its parts are broken or missing
- Should any problems arise, please contact our After Sales Service
- Manufacturer's instructions shall be followed at all times
- Care: Clean with a soft, dry cloth. In case of larger stains, carefully rub with a slightly damp, non-abrasive sponge
- Avoid the risk of fire by not placing furniture near sources of ignition or hot items
- Do not jump on the bed

Deutsch

WICHTIG ! ZUM SPÄTEREN NACHSCHLAGEN AUFBEWAHREN: SORGFÄLTIG LESEN

- Muss von einem Erwachsenen zusammengebaut werden. Der Zusammenbau muss vor dem Gebrauch von einem Erwachsenen überprüft werden
- WARNUNG! Bewahren Sie alle Schrauben, Kleinteile und Plastikbeutel außerhalb der Reichweite von Kindern auf
- Kennzeichnen Sie vor dem Zusammenbau alle Teile richtig
- Benutzen Sie Ihren Artikel niemals, wenn Teile gebrochen sind oder fehlen
- Sollten Probleme auftreten, wenden Sie sich bitte an unseren Kundendienst
- Die Anweisungen des Herstellers sind stets zu befolgen
- Pflege: Mit einem weichen, trockenen Tuch reinigen. Bei größeren Flecken vorsichtig mit einem leicht feuchten, nicht scheuernden Schwamm abreiben. nicht scheuernden Schwamm
- Vermeiden Sie die Gefahr eines Brandes, indem Sie die Möbel nicht in der Nähe von Zündquellen oder heißen Gegenständen aufstellen
- Nicht auf das Bett springen

Français

IMPORTANT ! CONSERVER POUR RÉFÉRENCE ULTÉRIEURE : LIRE ATTENTIVEMENT

- Le montage doit être effectué par un adulte. Le montage doit être vérifié par un adulte avant Utilisation
- ATTENTION ! Tenir les vis, les petites pièces et les sachets en plastique hors de portée des enfants
- Identifiez correctement toutes les pièces avant de les assembler
- N'utilisez jamais votre article si l'une de ses pièces est cassée ou manquante
- En cas de problème, veuillez contacter notre service après-vente
- Les instructions du fabricant doivent être respectées à tout moment
- Entretien : nettoyer avec un chiffon doux et sec. En cas de taches plus importantes, frotter soigneusement avec une éponge non abrasive légèrement humide. légèrement humide et non Abrasive
- Évitez les risques d'incendie en ne plaçant pas les meubles à proximité de sources d'inflammation ou d'objets chauds
- Ne pas sauter sur le lit

Italiano

IMPORTANTE! CONSERVARE PER RIFERIMENTO FUTURO: LEGGERE ATTENTAMENTE

- Deve essere assemblato da un adulto. L'assemblaggio deve essere controllato da un adulto prima dell'uso
- **ATTENZIONE!** Tenere tutte le viti, le piccole parti e i sacchetti di plastica fuori dalla portata dei bambini
- Identificare correttamente tutte le parti prima dell'assemblaggio
- Non utilizzare mai l'articolo se alcune parti sono rotte o mancanti
- In caso di problemi, si prega di contattare il nostro Servizio Post Vendita
- Le istruzioni del produttore devono essere sempre seguite
- Cura: Pulire con un panno morbido e asciutto. In caso di macchie più estese, strofinare accuratamente con una spugna leggermente umida e non spugna leggermente umida e non abrasiva
- Evitare il rischio di incendio, non collocando i mobili vicino a fonti di accensione o a oggetti caldi
- Non saltare sul letto

Español





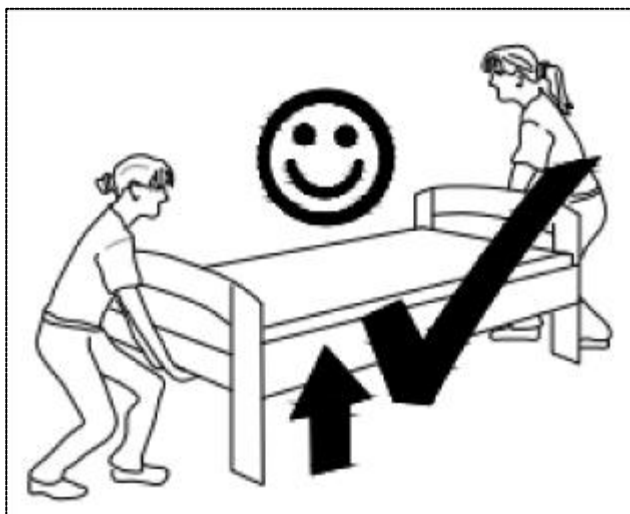
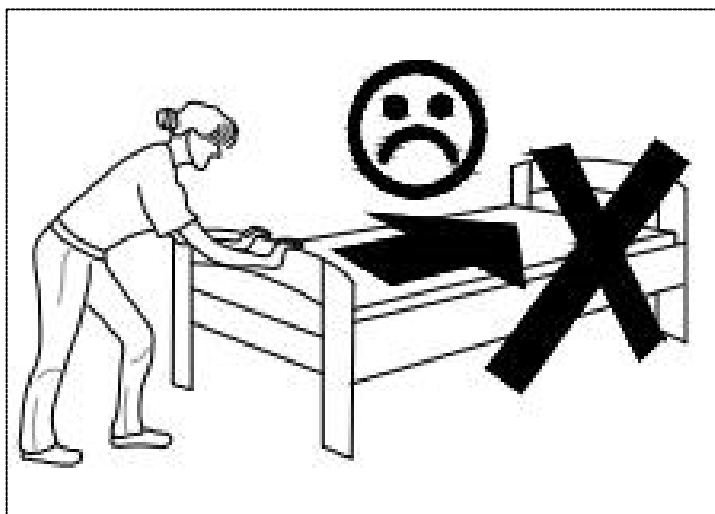

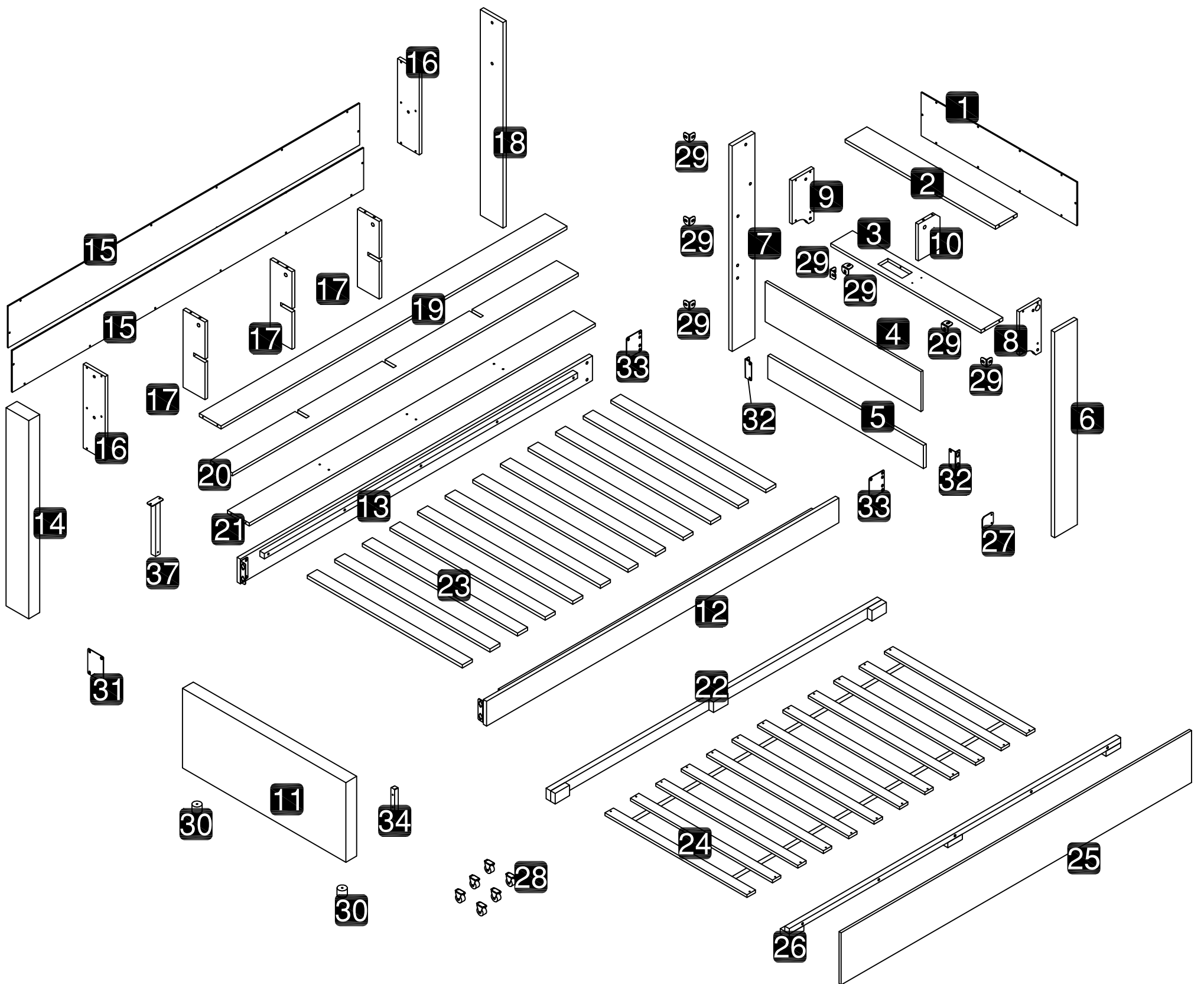

¡IMPORTANTE ! CONSERVELO PARA FUTURAS CONSULTAS: LEA ATENTAMENTE

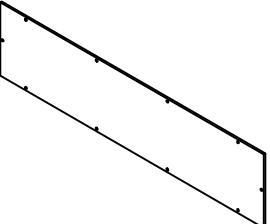
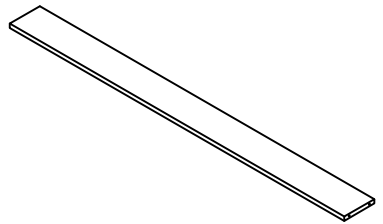
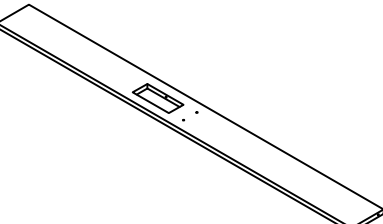
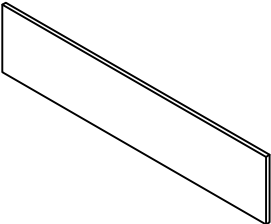
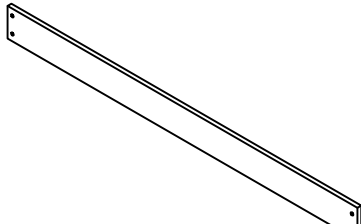
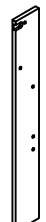
- Debe ser montado por un adulto. El montaje debe ser comprobado por un adulto antes del uso
- **ADVERTENCIA** Mantenga todos los tornillos, piezas pequeñas y bolsas de plástico fuera del alcance de los niños.
- Identifique correctamente todas las piezas antes de montarlas
- Nunca utilice su artículo si alguna de sus piezas está rota o falta
- Si surge algún problema, póngase en contacto con nuestro Servicio Postventa
- Las instrucciones del fabricante deben seguirse en todo momento
- Cuidado: Limpiar con un paño suave y seco. En caso de manchas más grandes, frote cuidadosamente con una esponja no abrasiva ligeramente humedecida.
- Evite el riesgo de incendio no colocando los muebles cerca de fuentes de ignición u objetos calientes.
- No saltar sobre la cama.

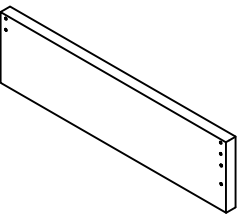

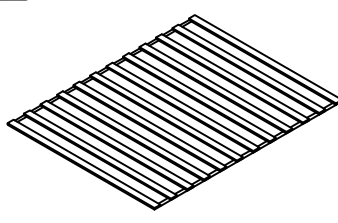
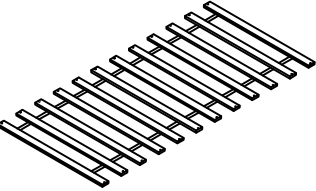
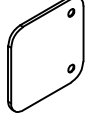

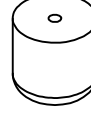
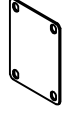
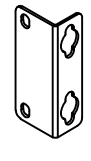
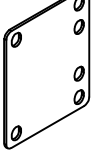

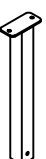
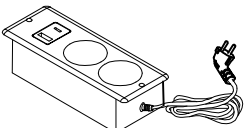
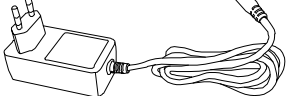
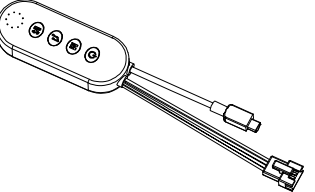
Part List-Teileliste-Liste des pièces N623P250219



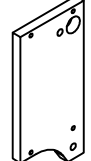
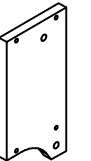
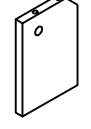
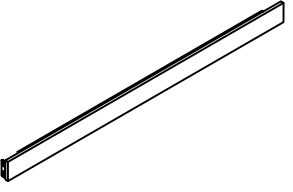
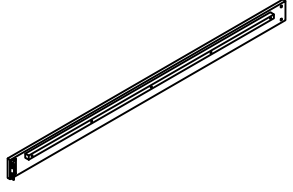
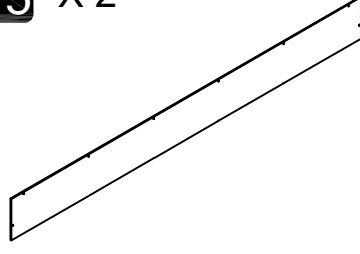

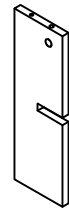
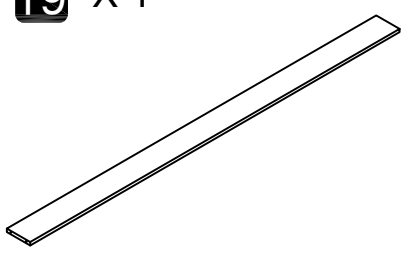
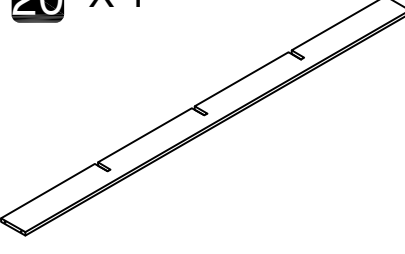
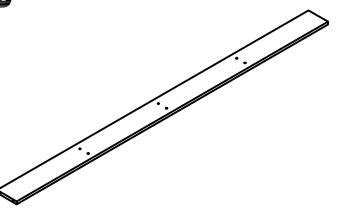
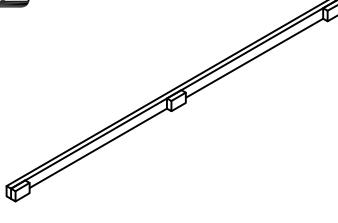
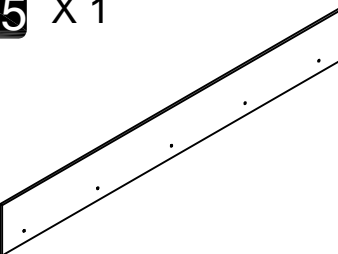
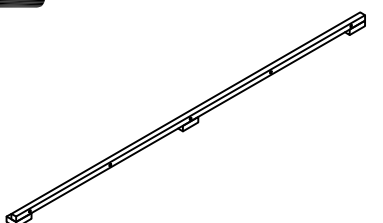

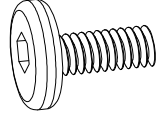
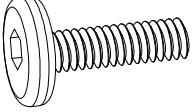
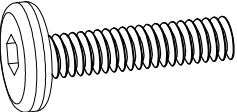

1 X 1 	2 X 1 	3 X 1 	4 X 1 	5 X 1 
6 X 1 	7 X 1 	11 X 1 	14 X 1 	18 X 1 
23 X 1 	24 X 1 	27 X 1 	28 X 6 	29 X 7 
30 X 2 	31 X 1 	32 X 2 	33 X 2 	34 X 1 
37 X 1 	U X 1 	V X 1 	W X 1 	

Part List-Teileliste-Liste des pièces N623P250220

8 X 1 	9 X 1 	10 X 1 	12 X 1 	13 X 1 
15 X 2 	16 X 2 	17 X 3 	19 X 1 	20 X 1 
21 X 1 	22 X 1 	25 X 1 	26 X 1 	

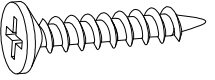
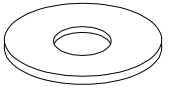
Hardware List-Hardware-Liste-Liste du matériel

N623P250219

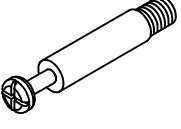
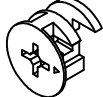
A X 22  M8x15mm	B X 12  M8x20mm	C X 8  M8x35mm	D X 7  M6x35mm
F X 24  φ3.0x20mm	G X 7  φ4.0x15mm	H X 2  φ4.0x35mm	J X 58  φ5.0x40mm
K X 4 	L X 1 	M X 4 	N X 24  φ4.0x28mm
P X 4 	Q X 4 		

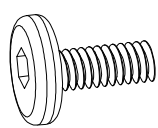
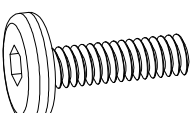
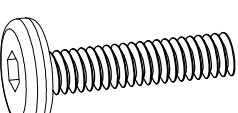
A  M8x15mm	B  M8x20mm	C  M8x35mm
--	--	--

DE:Bitte beachten Sie, dass die Formen der Schrauben A und B und C ähnlich sind. Bitte installieren Sie entsprechend der Anleitung und unterscheiden Sie sie!

UK>Please note that the shapes of screws A and B and C are similar. Please install according to the instructions and distinguish them!

FR:Notez que les vis A et B et c ont des formes similaires. Veuillez les installer en suivant les instructions pour les séparer!

G  φ4.0x15mm	H  φ4.0x35mm	N  φ4.0x28mm
--	--	--

DE:Bitte beachten Sie, dass die Formen der Schrauben G und H und N ähnlich sind. Bitte installieren Sie entsprechend der Anleitung und unterscheiden Sie sie!

UK>Please note that the shapes of screws G and H and N are similar. Please install according to the instructions and distinguish them!

FR:Notez que les vis G et H et N ont des formes similaires. Veuillez les installer en suivant les instructions pour les séparer!

1

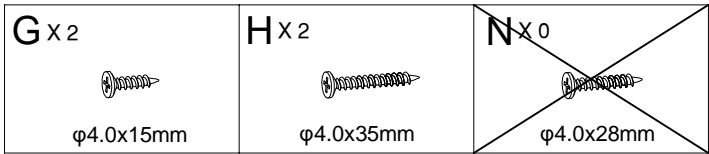
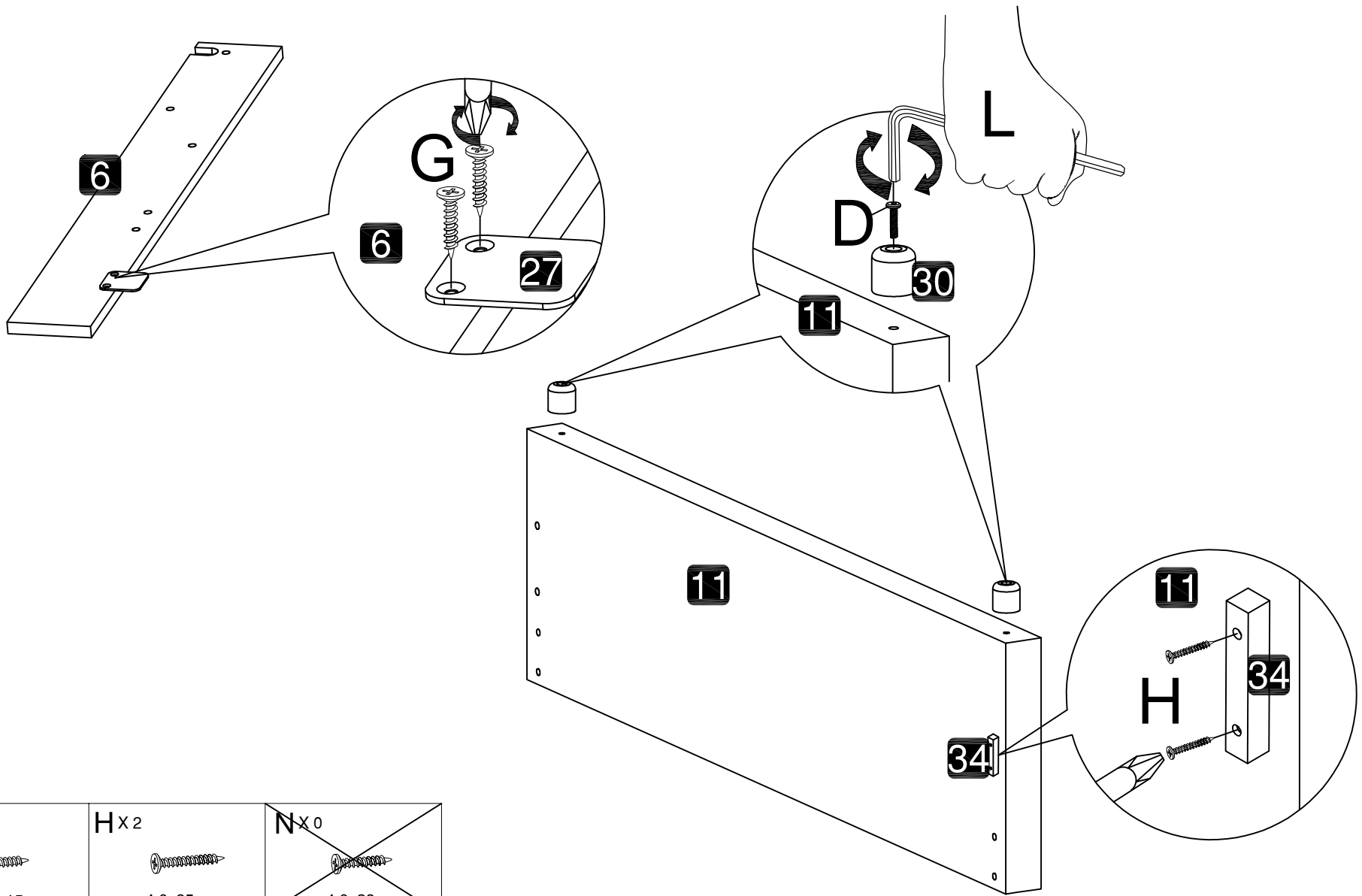
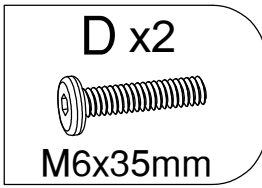
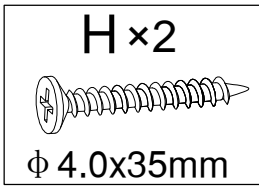
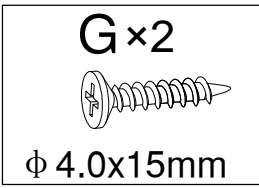
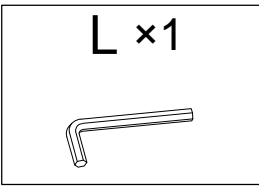

2

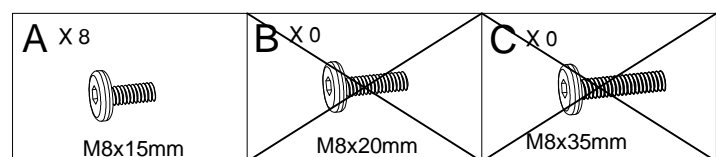
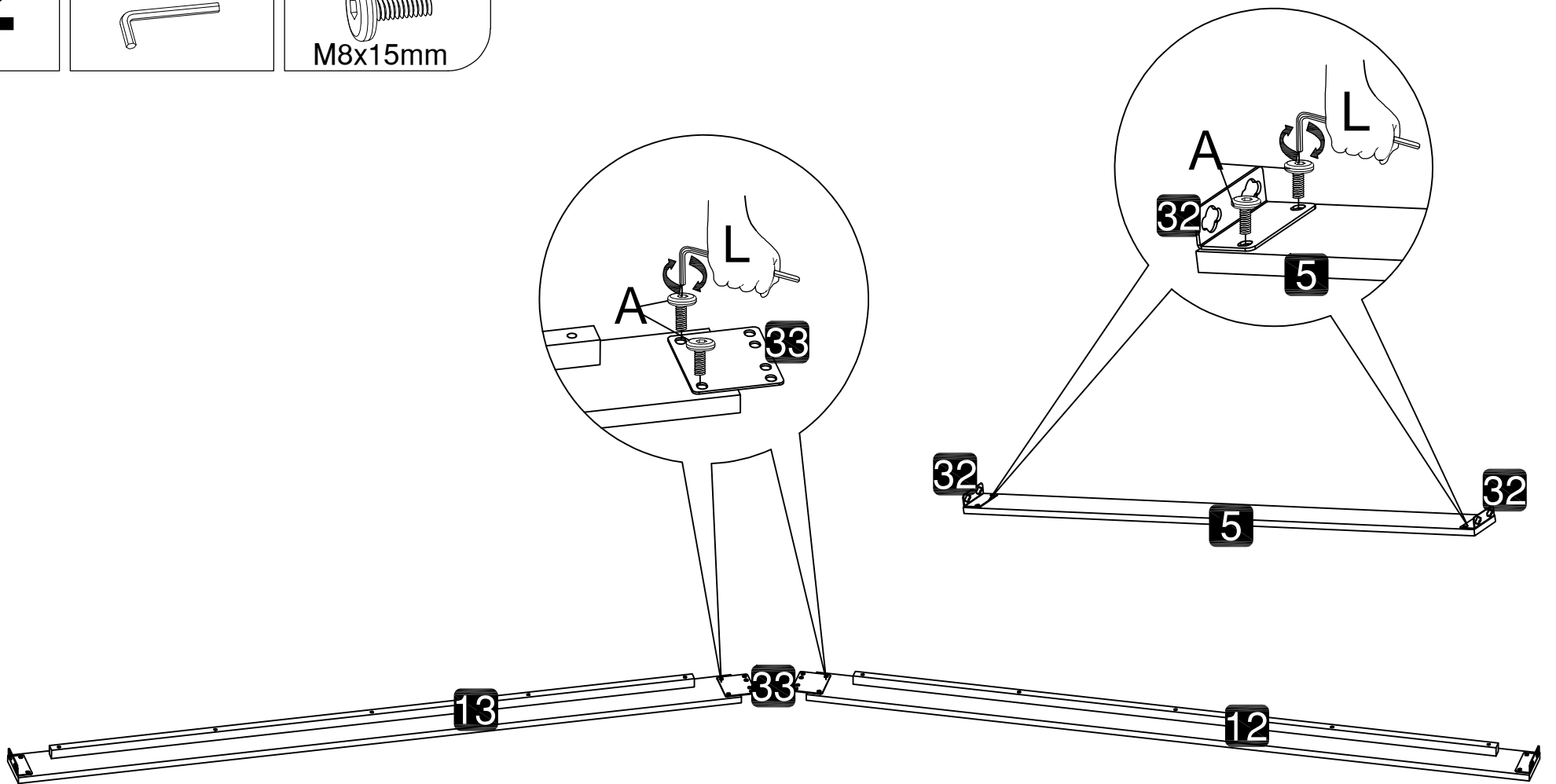
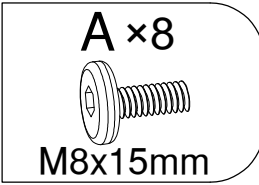
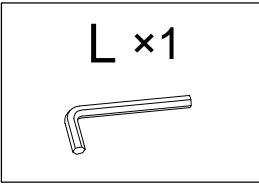

3

L x 1



A x 6



M8x15mm

B x 12



M8x20mm

A x 6



M8x15mm

B x 12



M8x20mm

C x 0



M8x35mm

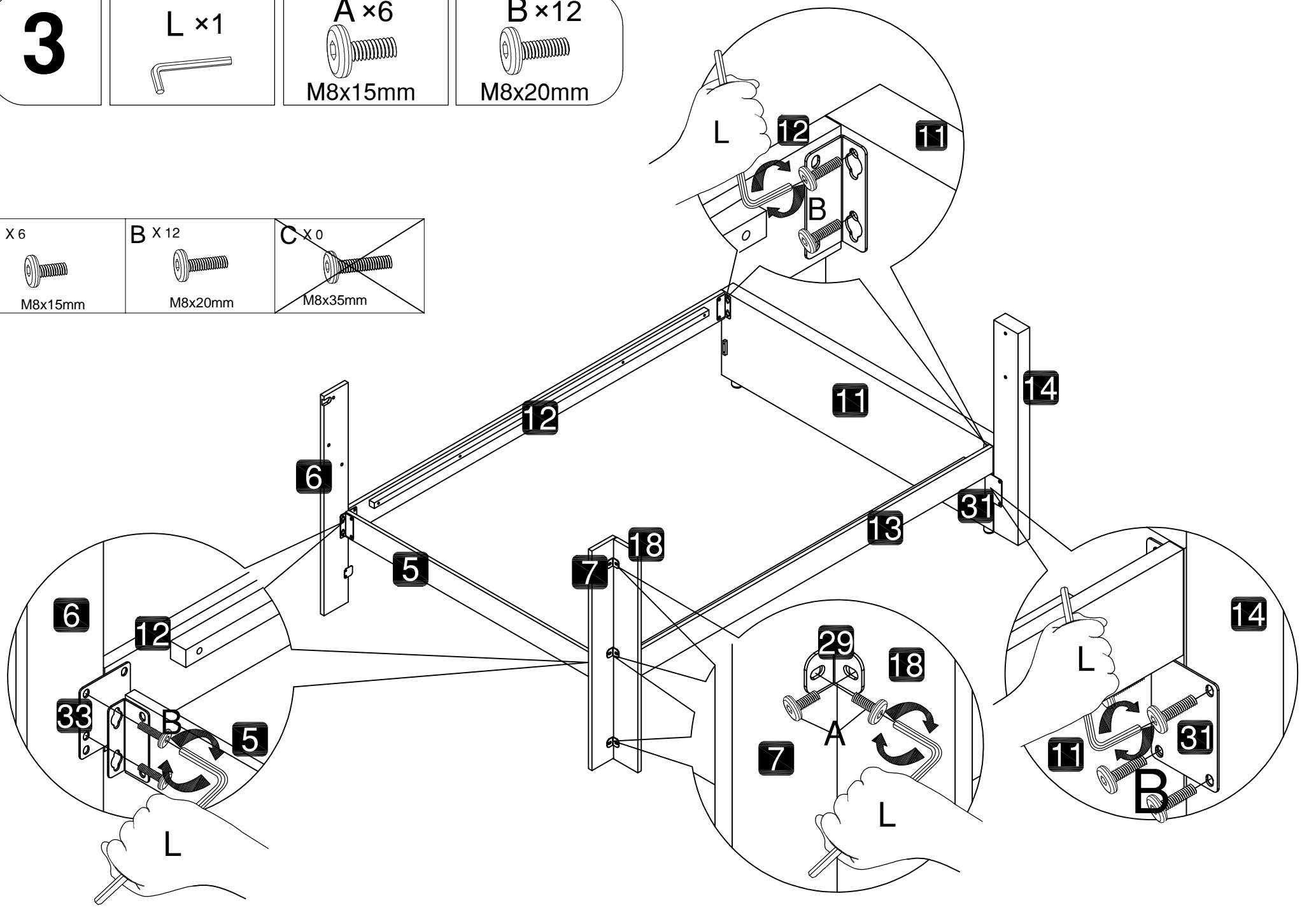

4

G x 2

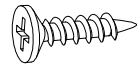

φ4.0x15mm

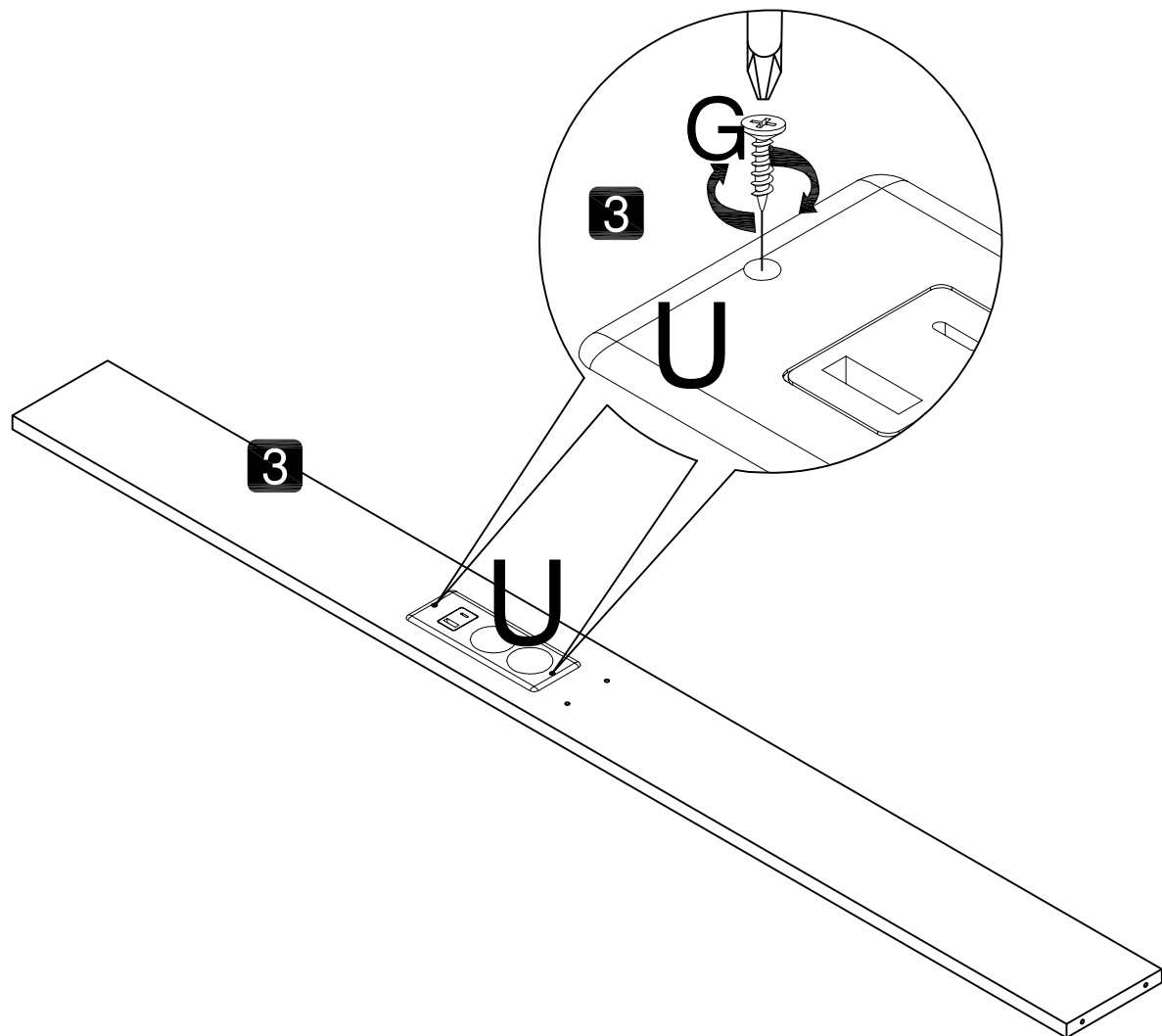

G x 2



φ4.0x15mm

H x 0



φ4.0x35mm

N x 0



φ4.0x28mm

5

M x 1



P x 1

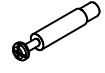

Q x 1

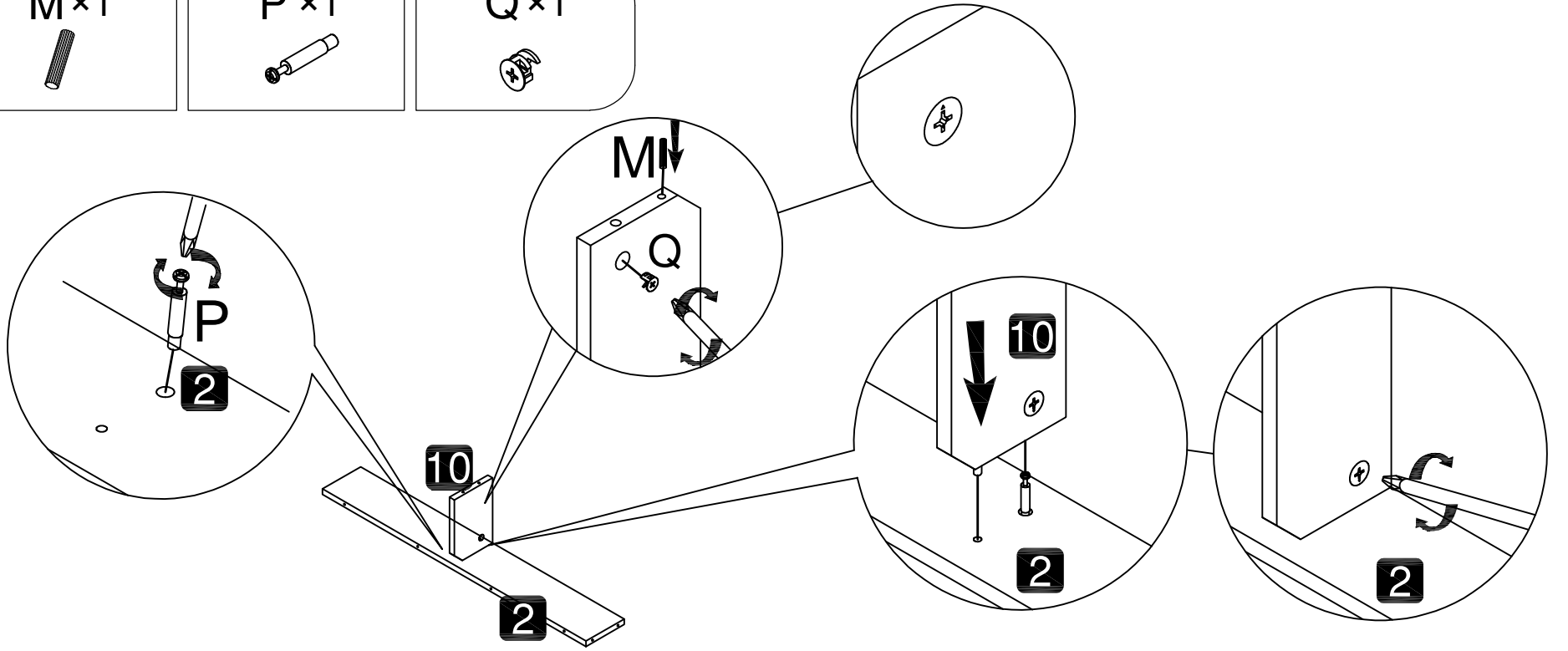

6

J x 10

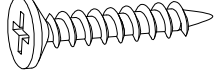

φ 5.0x40mm

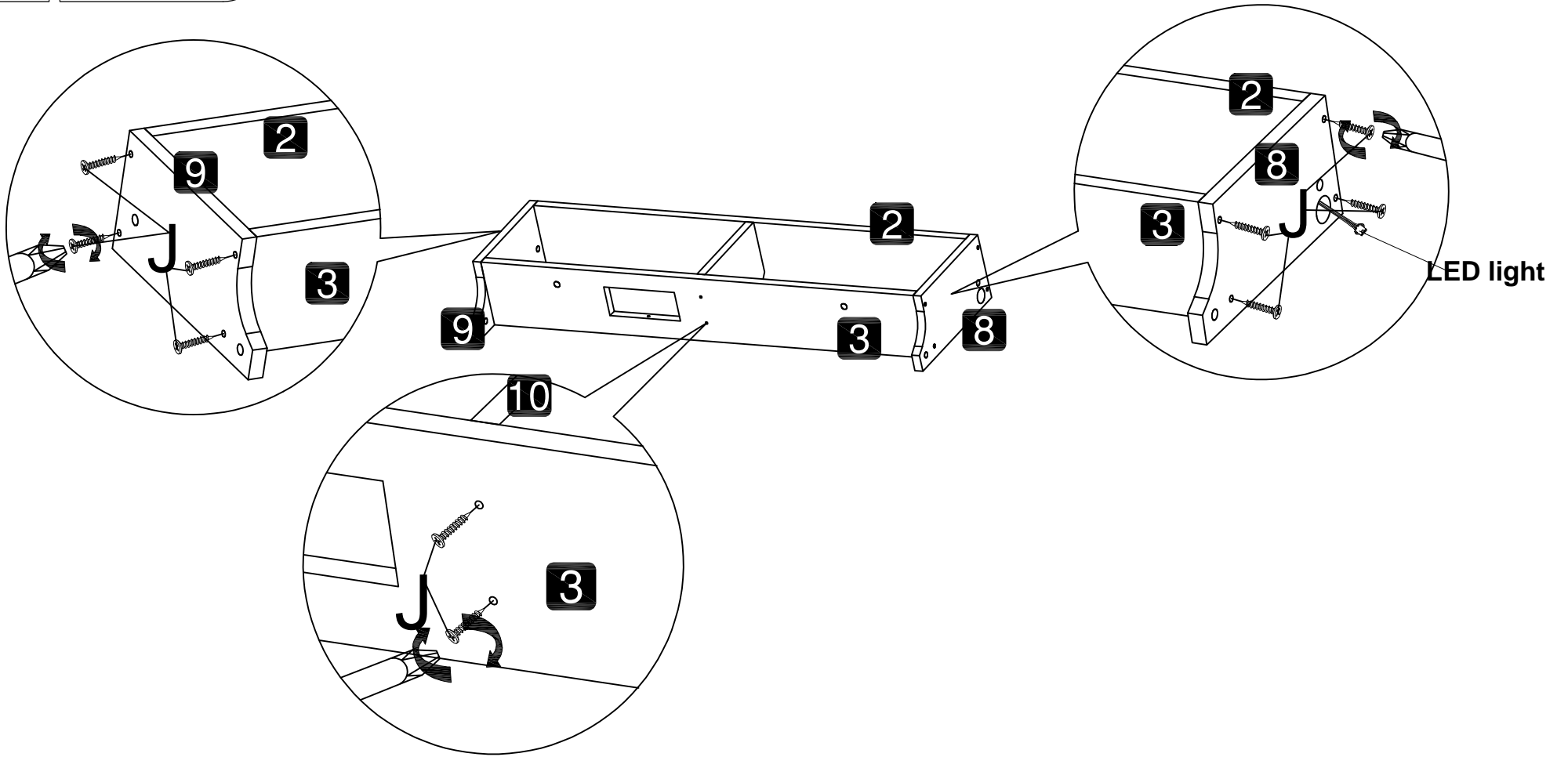

7

J x 10

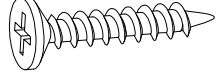

φ 5.0x40mm

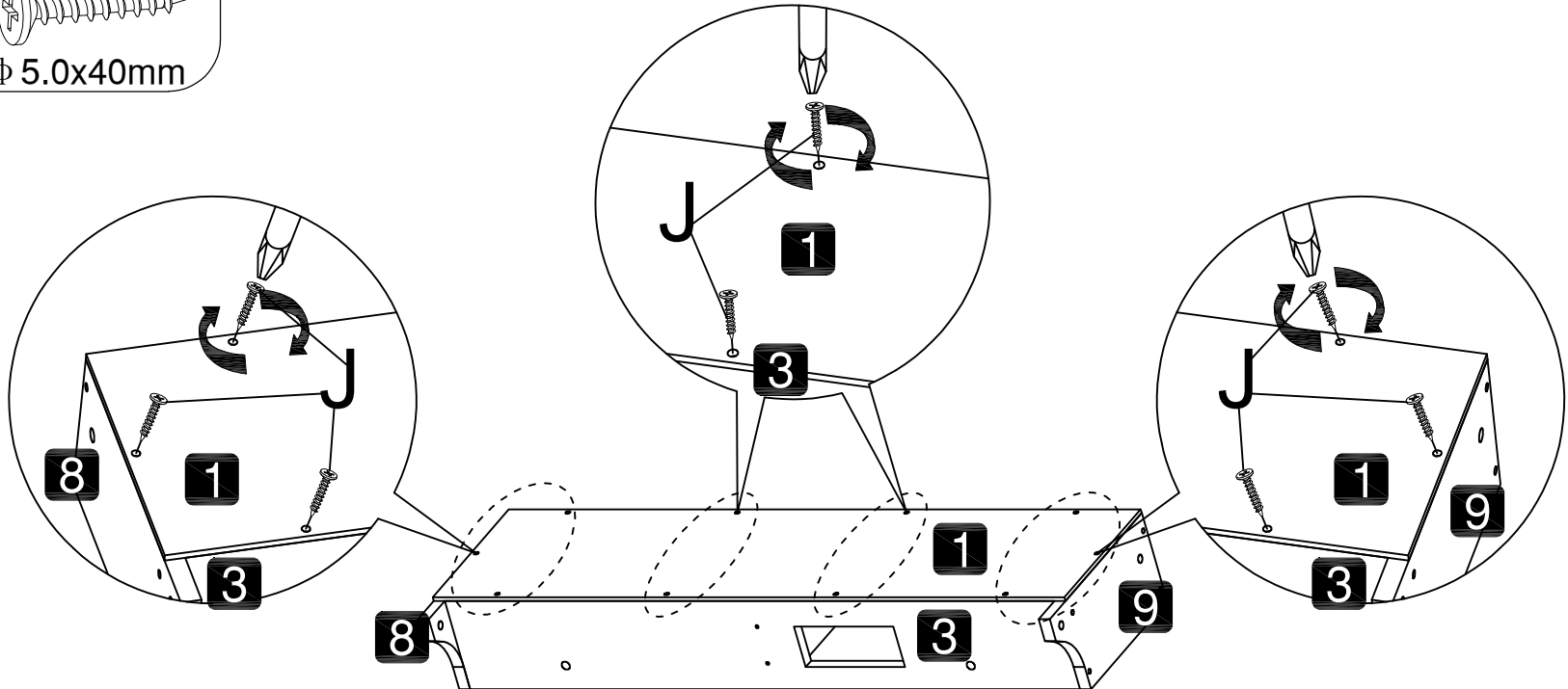

8

L x 1



C x 4

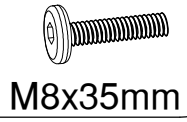

M8x35mm

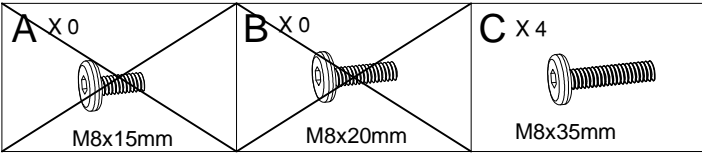
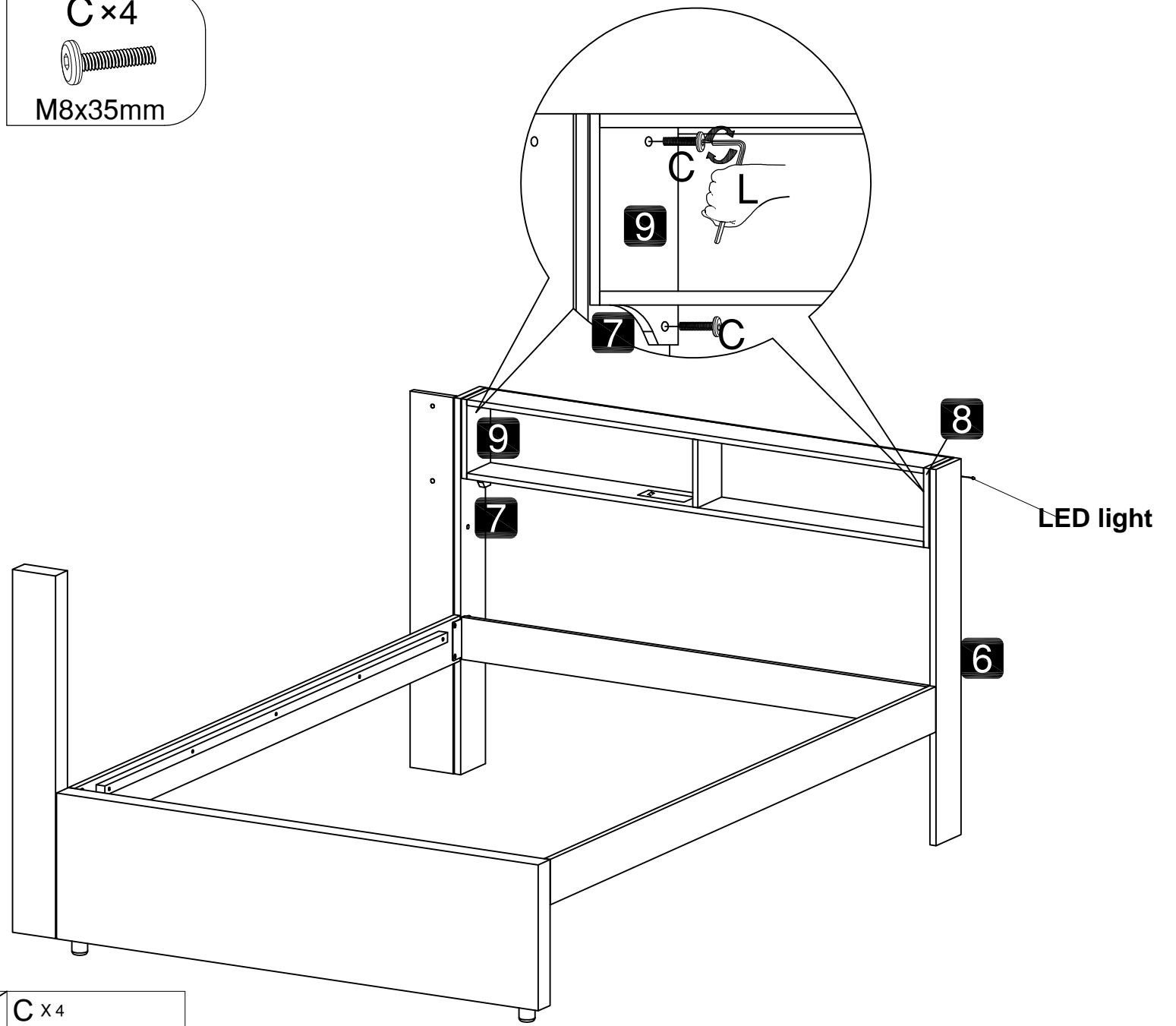

9

L x 1



A x 8

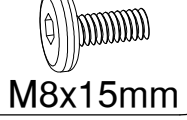

M8x15mm

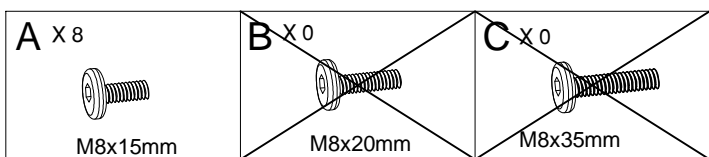
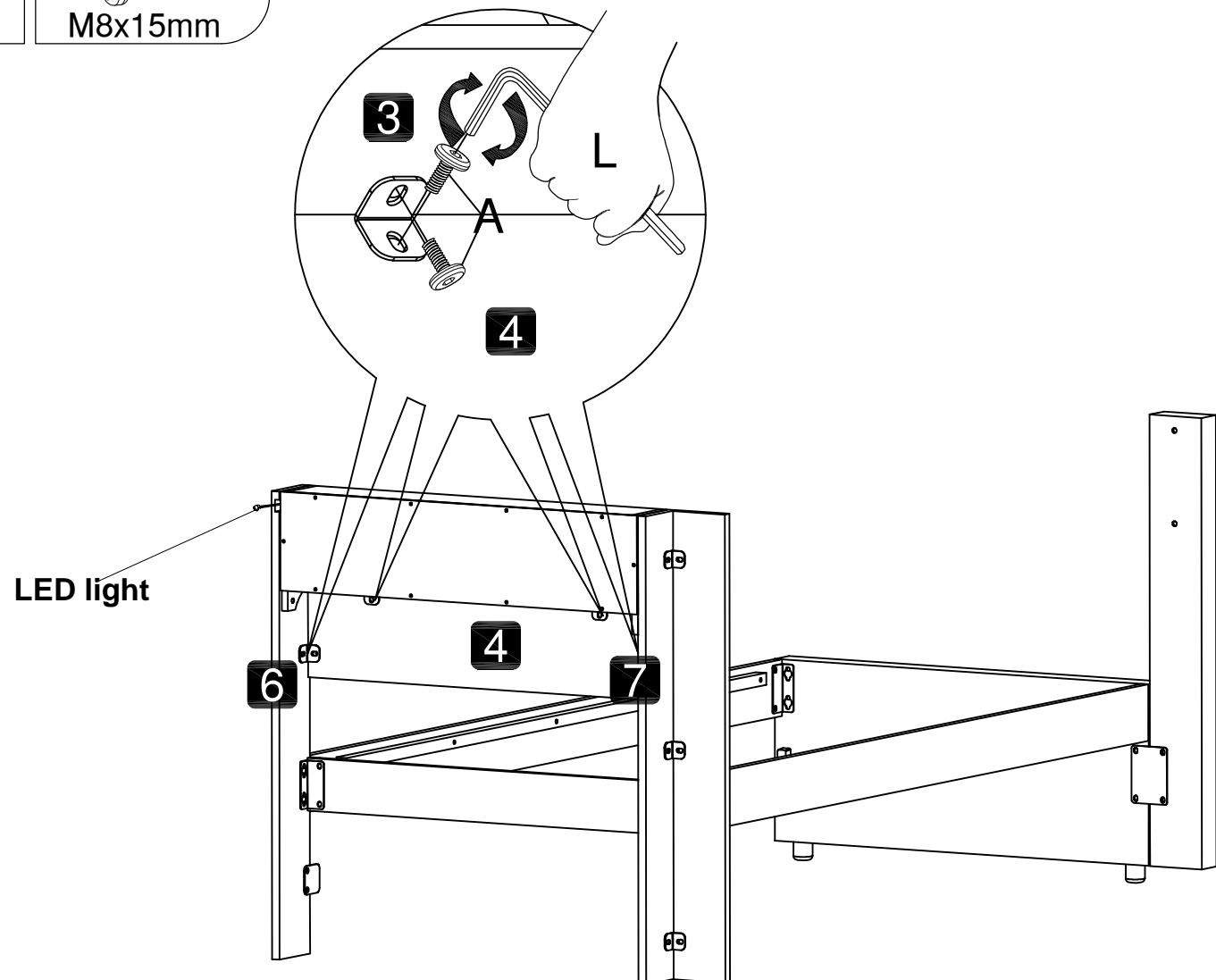

10

M x 3



P x 3

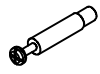

Q x 3

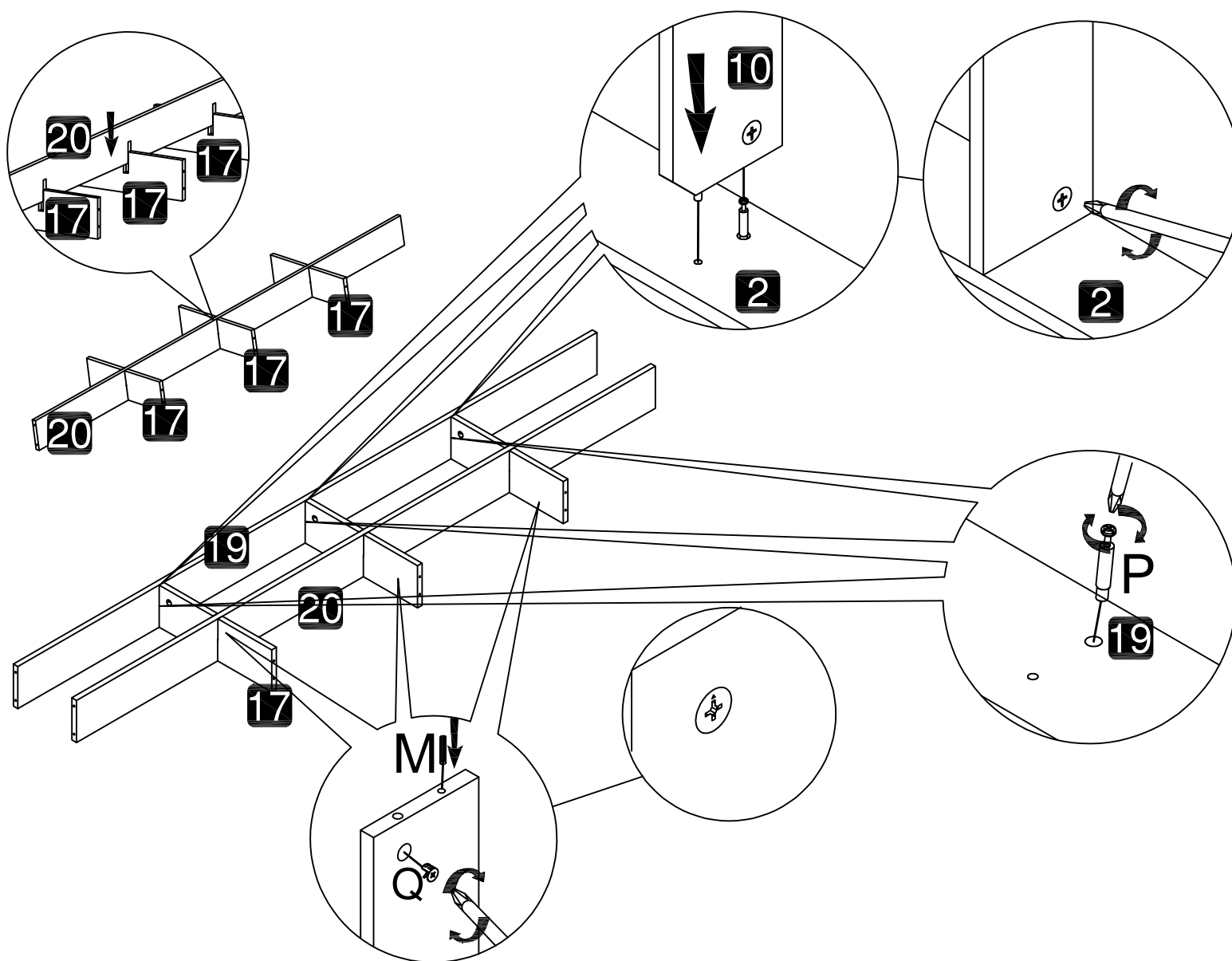

11

J x 18

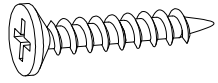

φ 5.0x40mm

DE: Hinweis: Bitte beachten Sie die Installationsrichtung von (16)
UK: Note: Please pay attention to the installation direction of (16)
FR: Remarque : Veuillez faire attention à la direction d'installation de (16)
ES: Nota: Preste atención a la dirección de instalación de (16).
IT: Nota: Prestare attenzione alla direzione di installazione di (16).

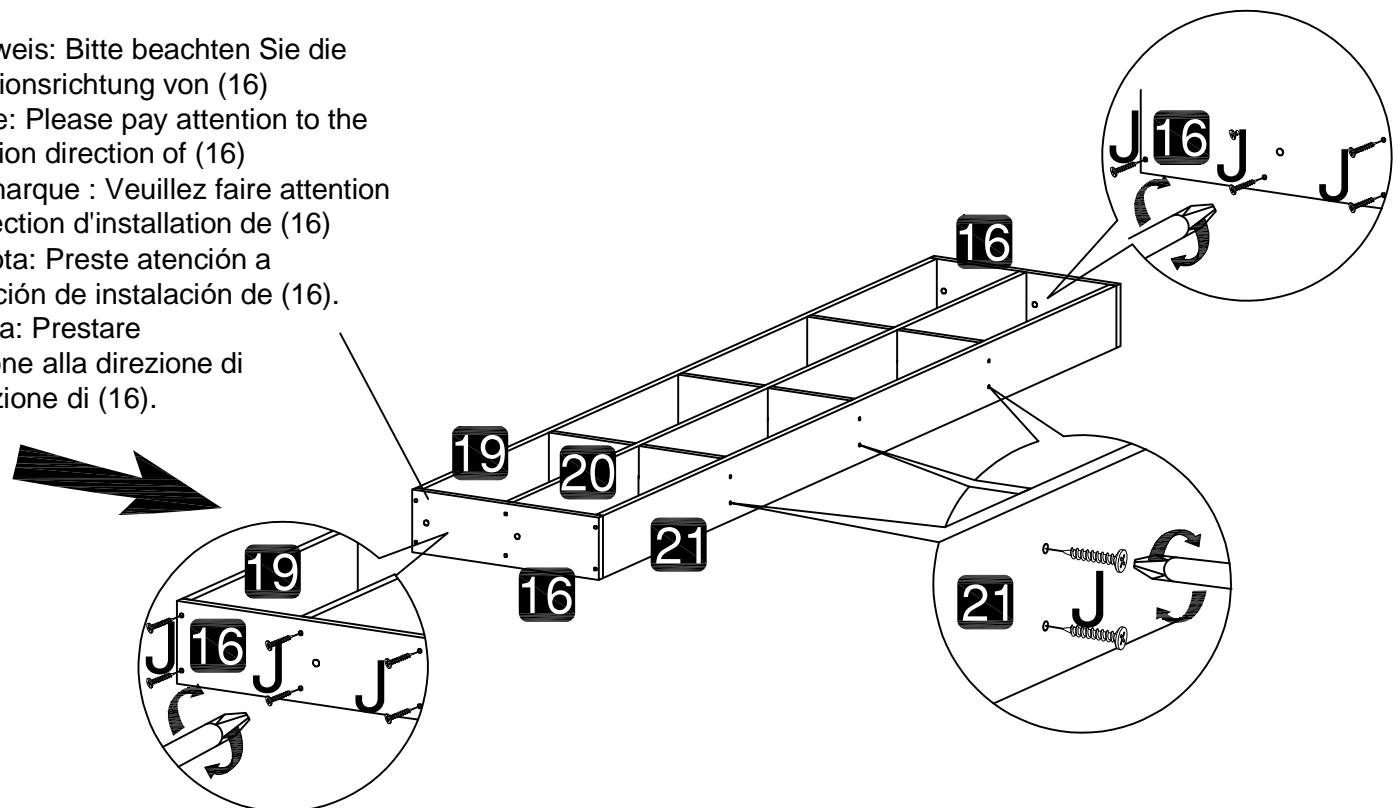

12

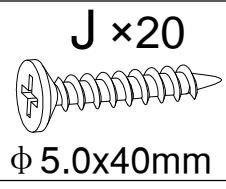

K x 4

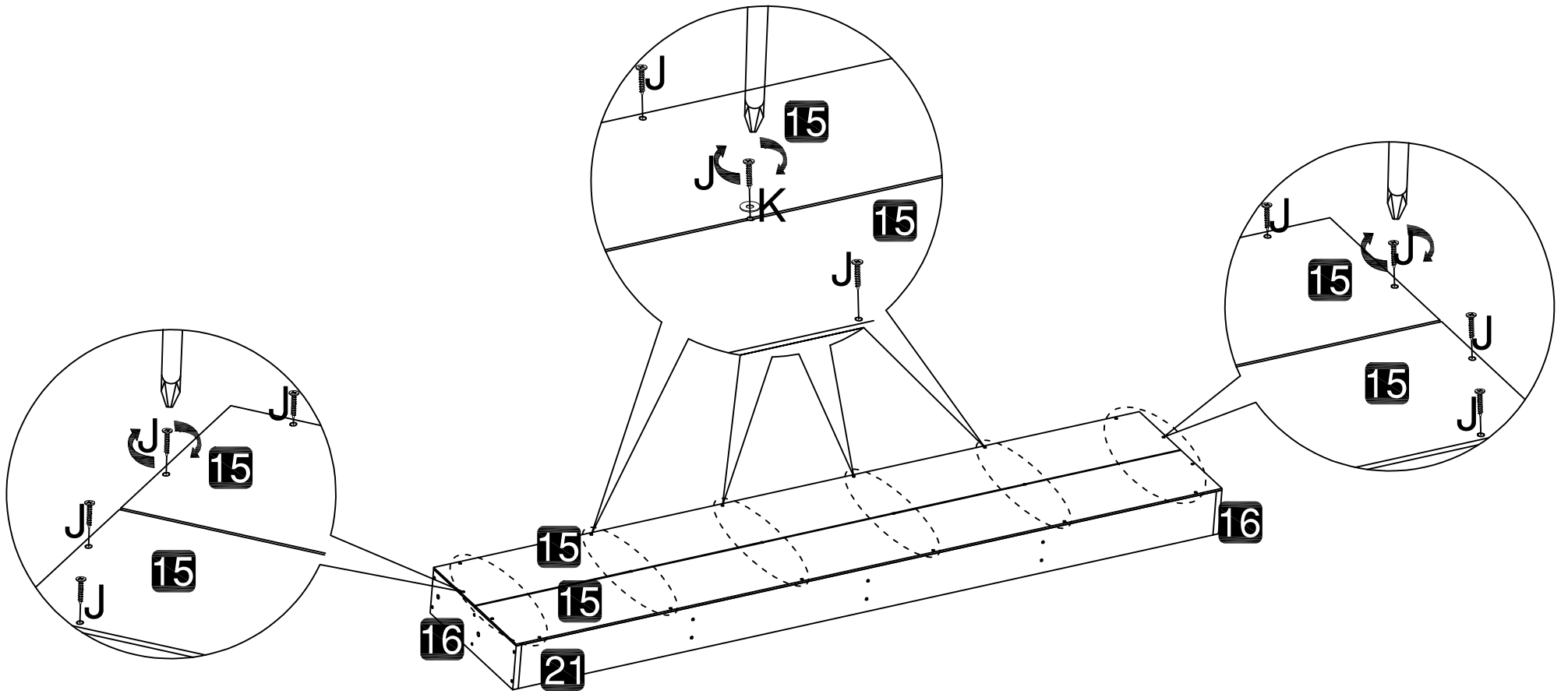

13

L x 1



C x 4

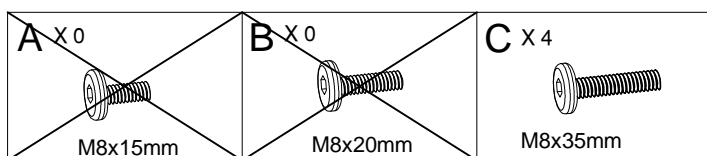
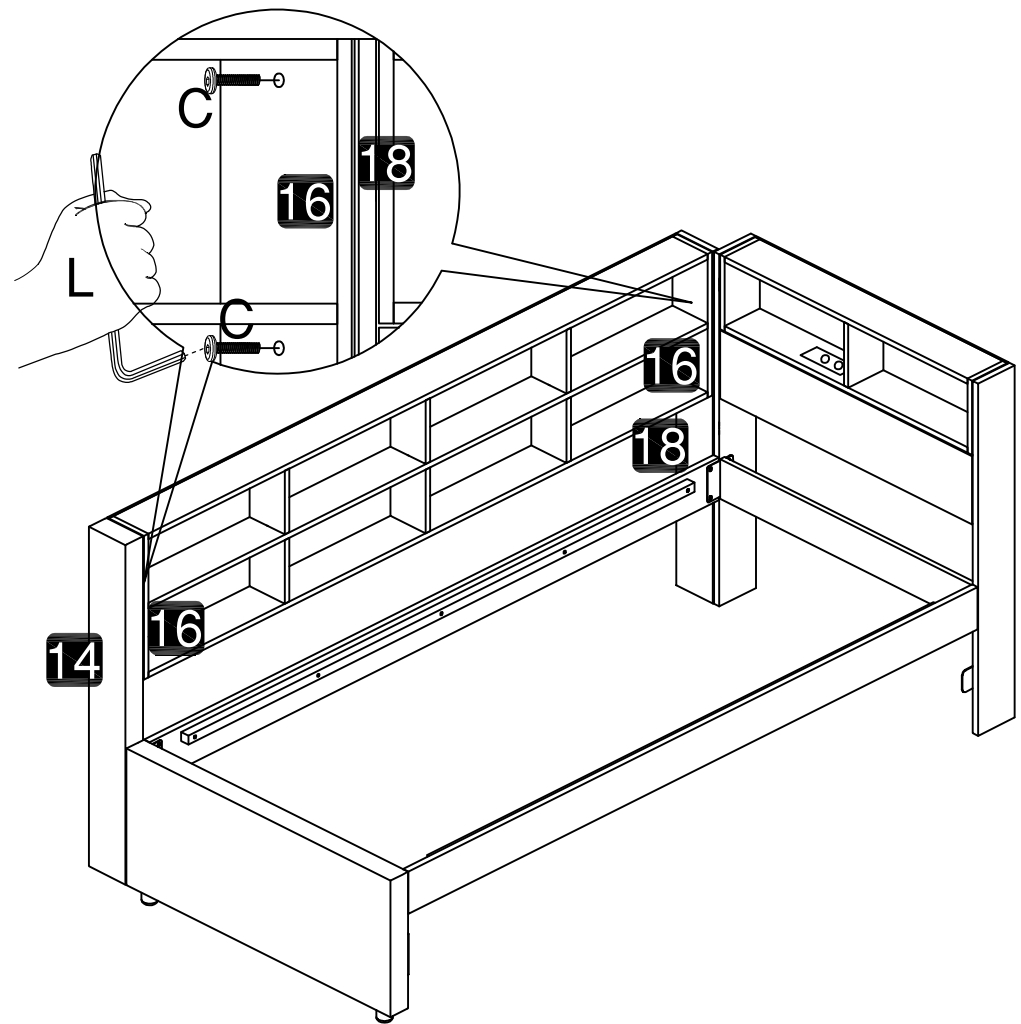
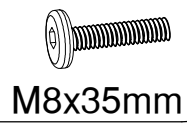

14

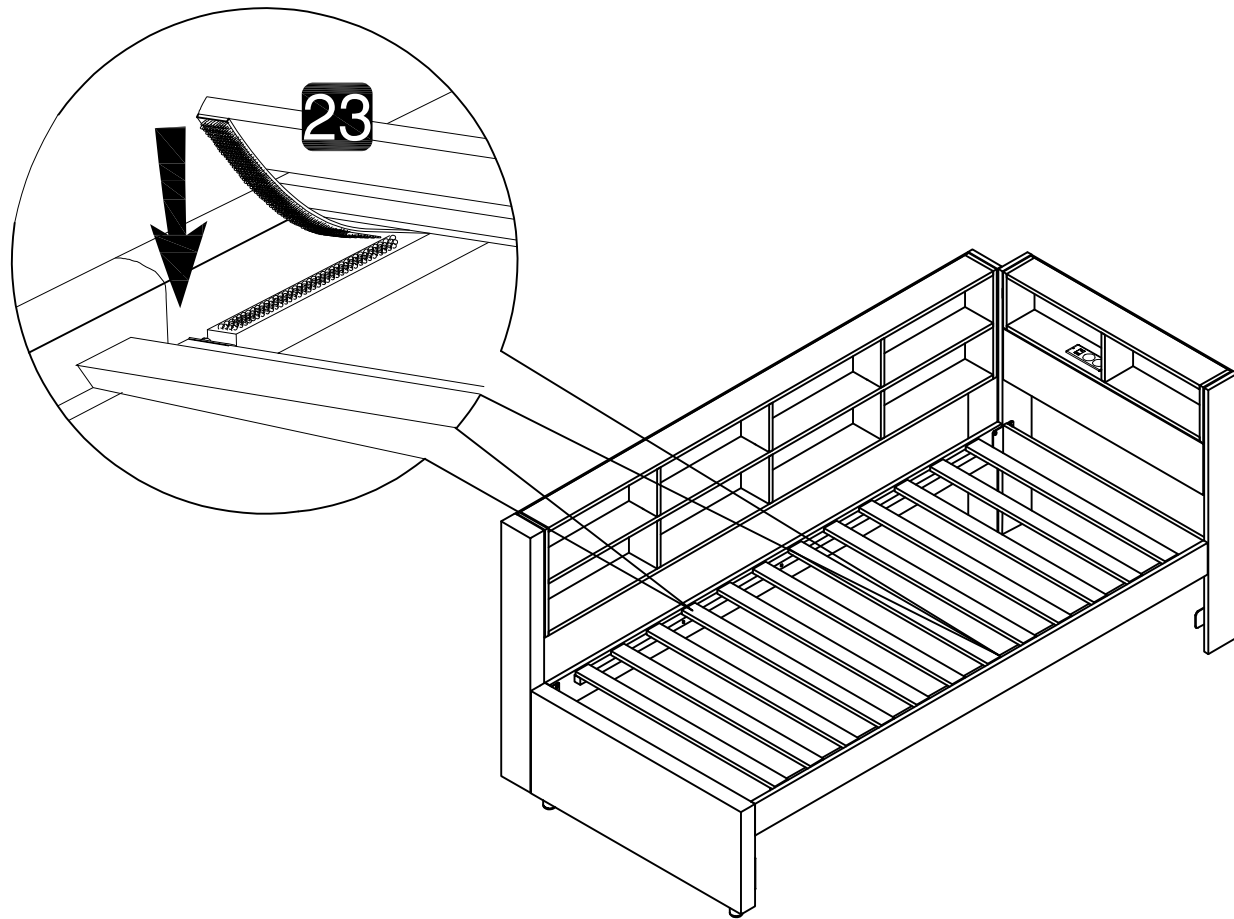

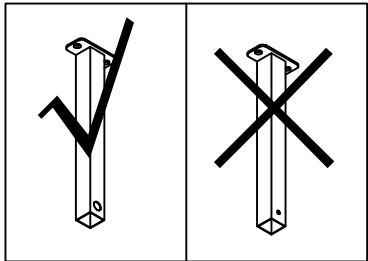
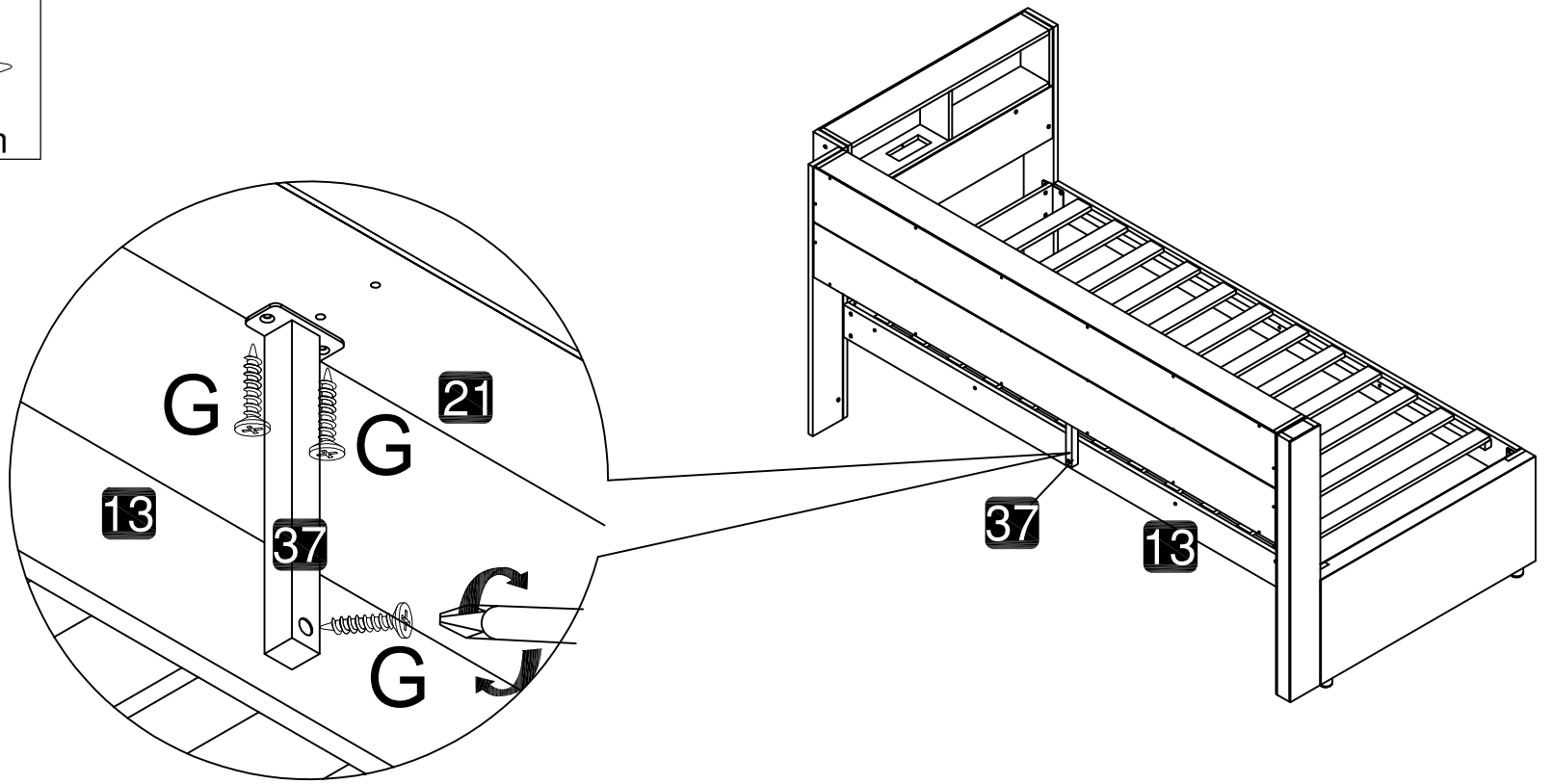

15

G x 3

φ 4.0x15mm



16

L x 1

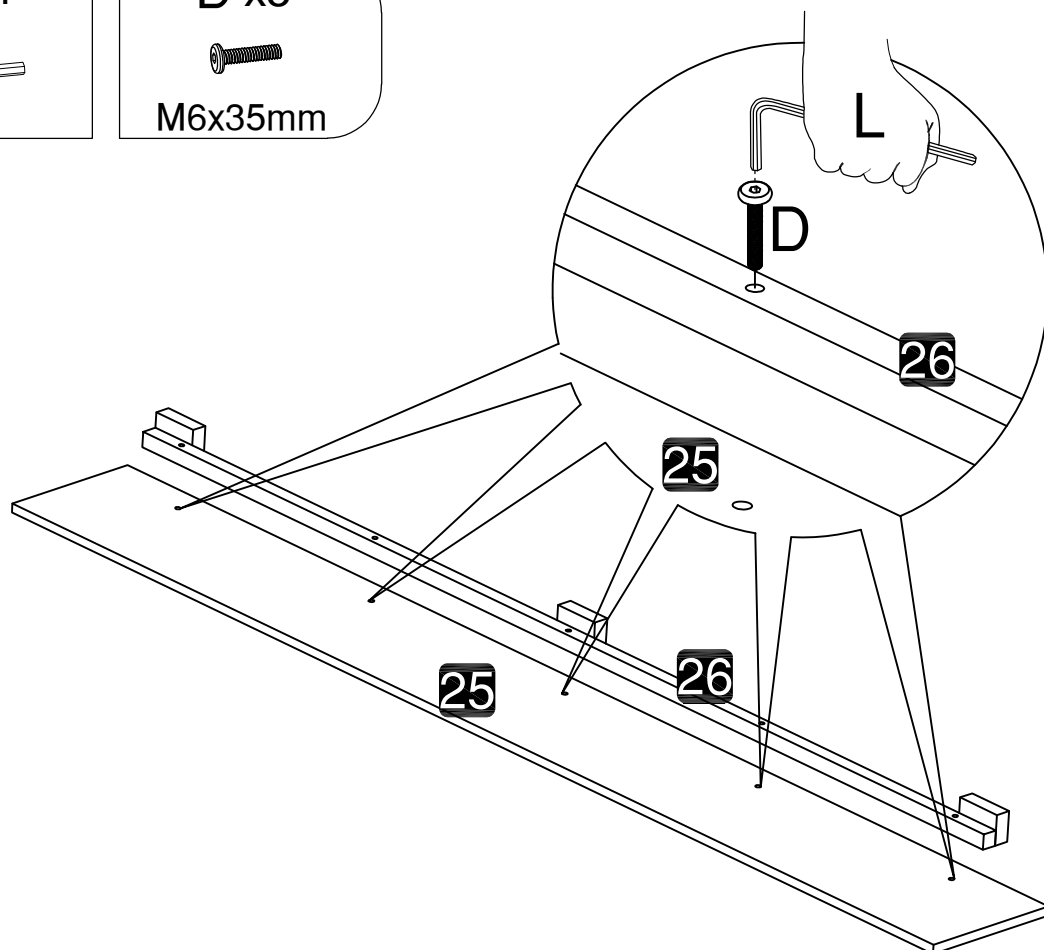
D x 5

M6x35mm

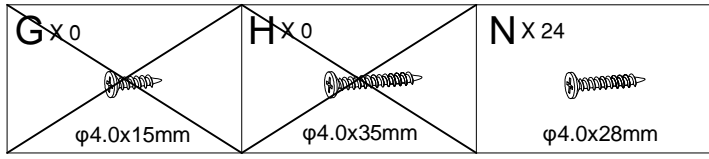
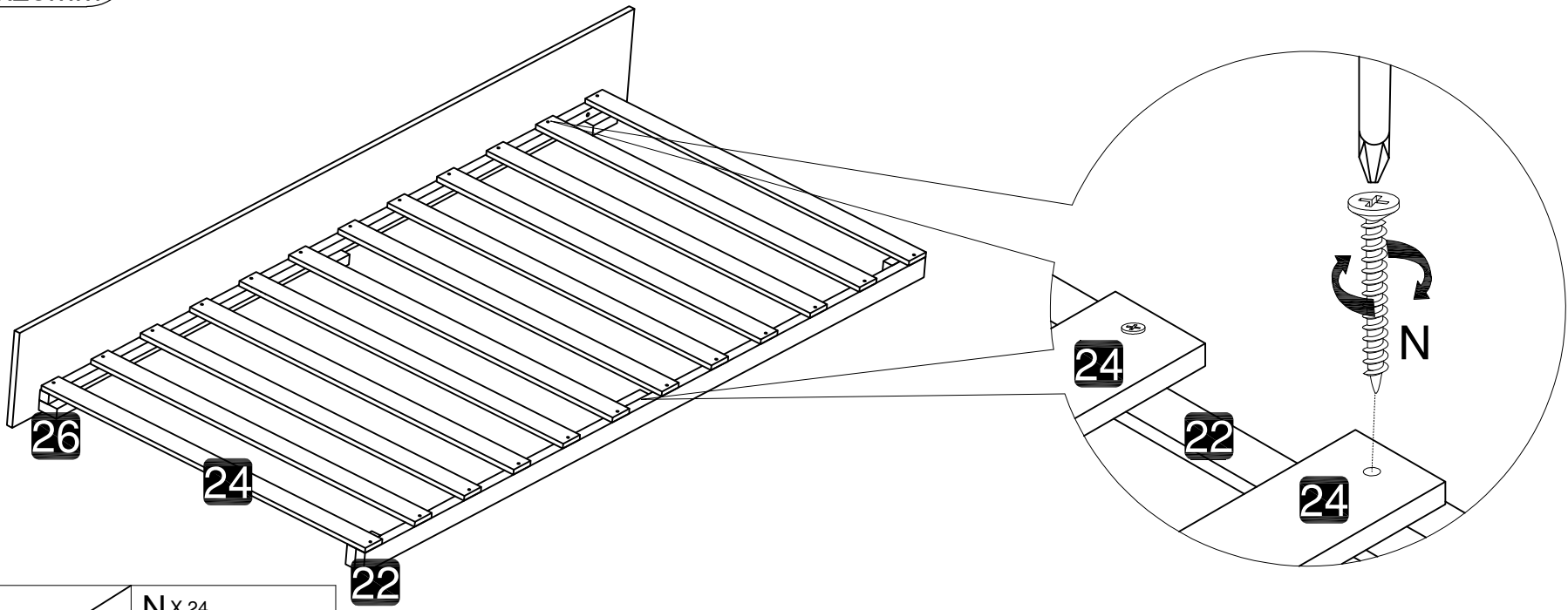

17

N x 24
φ 4.0x28mm



18

F x 24
φ 3.0x20mm

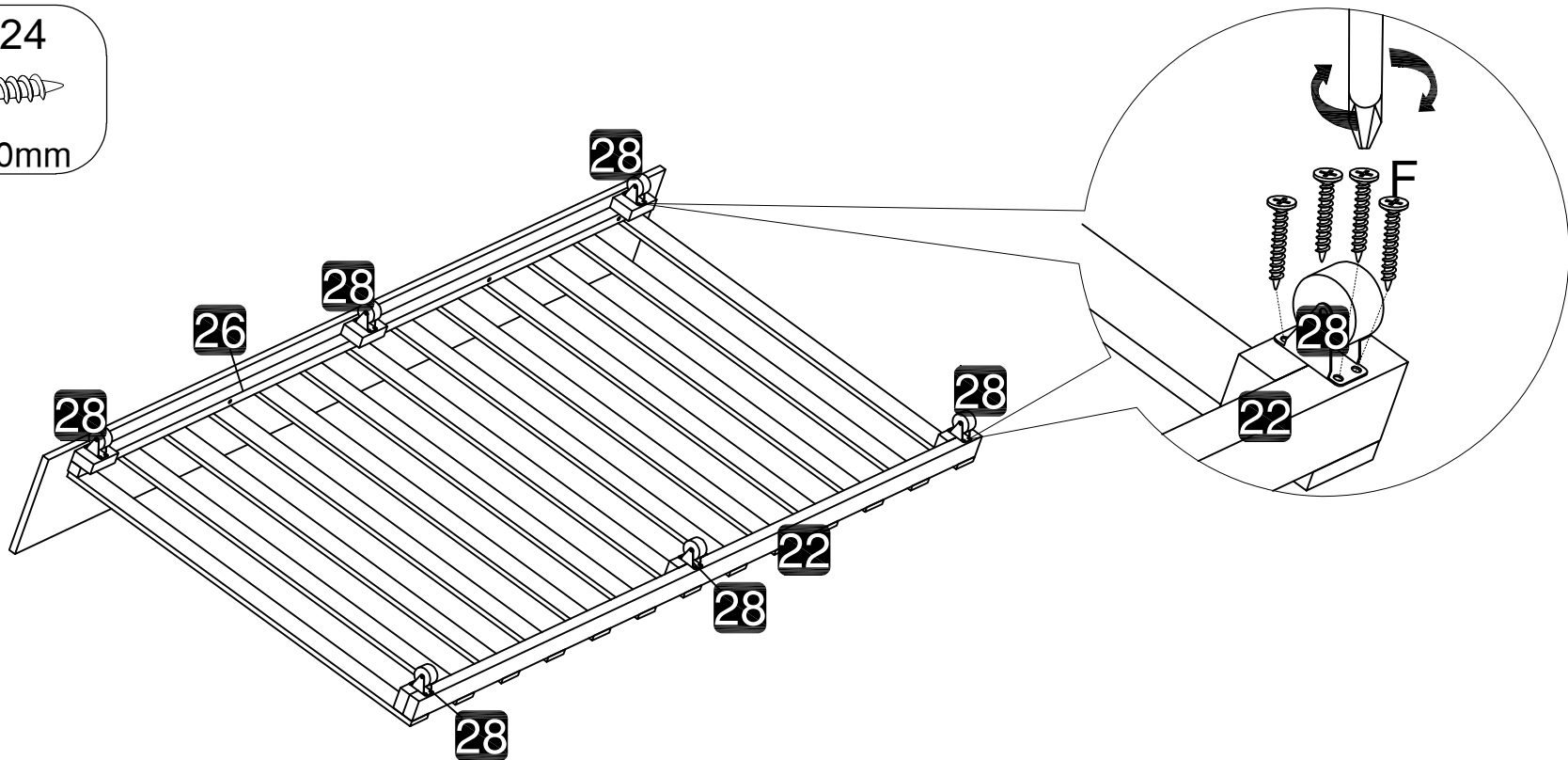

19

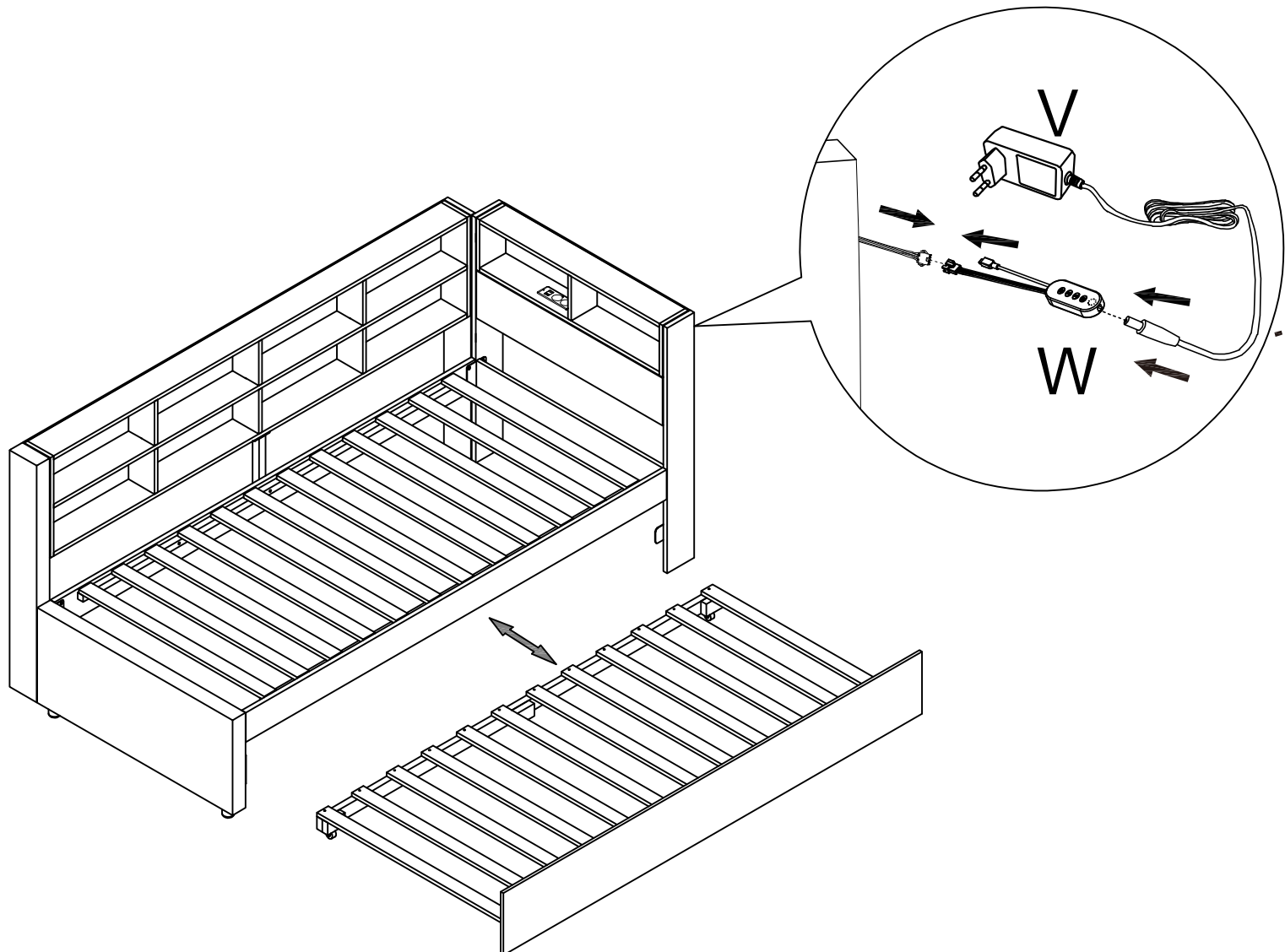

LED light

If you can't let the lights work successfully, please check the following:

1. Please check the direction of the connect, try it in the opposite direction, according to the following picture.
2. Please check if the positive and negative directions of the battery are installed correctly.
3. If one of the colors is not bright, please check whether the four wires in the plug are skewed, and move the main line to make the four wires flush.

(LED-Licht)

(Wenn Sie die Lampe nicht erfolgreich funktionieren lassen, überprüfen Sie bitte Folgendes:

1. Bitte überprüfen Sie die Verbindungsrichtung und versuchen Sie in der entgegengesetzten Richtung gemäß der Abbildung unten.
2. Bitte überprüfen Sie, ob die positive und negative Richtung der Batterie korrekt installiert sind.
3. Wenn eine der Farben nicht hell ist, überprüfen Sie bitte, ob die vier Drähte im Stecker schief sind, und bewegen Sie die Hauptleitung, um die vier Drähte bündig zu machen.)

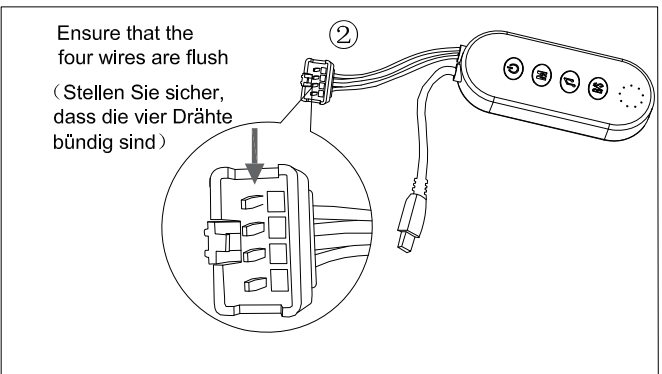
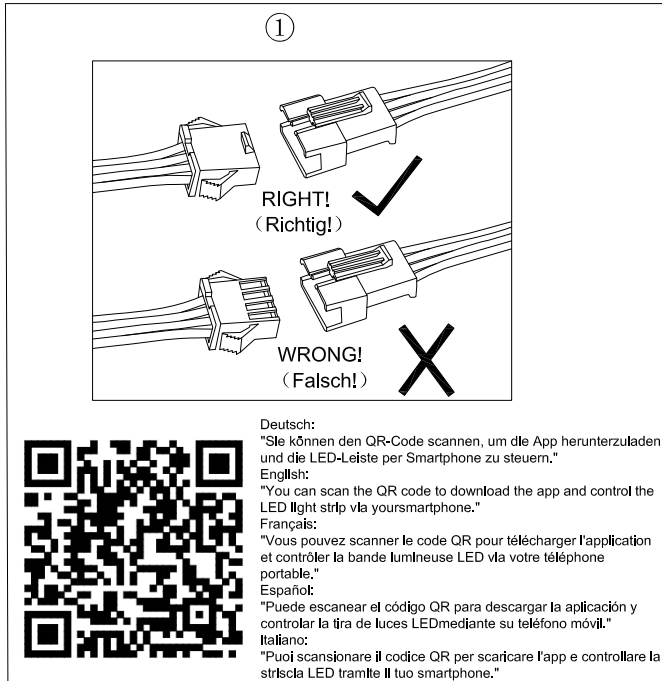

Operation Instructions of Controller (Betriebsanleitung des Reglers)

Technical parameter : (Technische parameter :)

<ul style="list-style-type: none"> • working temperature : -20-60°C (• Betriebstemperatur : -20-60°C) 	<ul style="list-style-type: none"> • output : 3CH/ RGB (• Ausgang: 3CH/ RGB)
<ul style="list-style-type: none"> • working voltage : DC5-24V (• Arbeitsspannung: DC5-24V) 	<ul style="list-style-type: none"> • receiving range : <10 meters (• Akzeptanzbereich: <10 meters)
<ul style="list-style-type: none"> • product power : 5V=30W 12V=72W 24V=144W (• Produktleistung : 5V=30W 12V=72W 24V=144W) 	

Introduction to remote control button function : (Einführung in die Funktionen die Fernbedienung)

Button (Taste)		Function (Funktion)
	ON / OFF (Ein / Aus)	Turn on / off the LED controller (LED-Controller ein-/ausschalten)
	Multiple color keys (Mehrfarbige Tasten)	Multiple color modes, can be switched (Brightness adjustable) [Mehrere Farbmuster, wechselbar (einstellbare Helligkeit)]
	music (musik)	5 music modes , can switch (5 Musikmodi , die geschaltet werden können)
	Speed / brightness+ Speed / brightness- (Geschwindigkeit/Helligkeit+ Geschwindigkeit/Helligkeit-)	Adjust brightness in static mode . Adjust speed in flash mode . (Helligkeit im statischen Modus anpassen. Geschwindigkeit im Blitzmodus einstellen.)

III. Panel specification and connecting drawing as follows: (Plattenspezifikation und Anschlusszeichnung wie folgt)

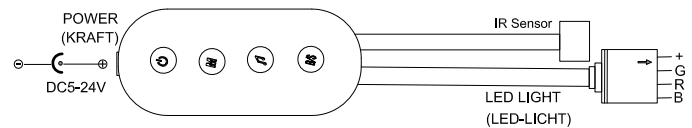



Certificate of Conformity

Certificate Number: DL-20230412023C

Applicant: Shenzhen Blue The Light Technology co., Ltd.
 Floor 4, Building 2, Hongxing Industrial Park, Yuanling Village, Shiyan Town, Baoan District, Shenzhen, China

Manufacturer: Shenzhen Blue The Light Technology co., Ltd.
 Floor 4, Building 2, Hongxing Industrial Park, Yuanling Village, Shiyan Town, Baoan District, Shenzhen, China

Product: LED Strip

Model No.: LG-5050-60L, LG-5050-30L, LG-5050-72L, LG-5050-84L, LG-5050-96L, LG-5050-120L, LG-2835-60L, LG-2835-90L, LG-2835-96L, LG-2835-108L, LG-2835-120L, LG-2835-140L, LG-2835-160L, LG-2835-240L

Test Standard: EN IEC 55015:2019+A11:2020, EN IEC 61000-3-2:2019+A1:2021, EN 61000-3-3:2013+A1:2019+A2:2021, EN 61547:2009, EN 61000-4-2:2009, EN IEC 61000-4-3:2020, EN 61000-4-4:2012, EN 61000-4-5:2014+A1:2017, EN IEC 61000-4-6:2022, EN 61000-4-8:2010, EN IEC 61000-4-11:2020

The EUT described above has been tested by us with the listed standards and found in compliance with the council EMC directive 2014/30/EU. It is possible to use CE marking to demonstrate the compliance with this EMC Directive. It is only valid in connection with the test report number: DL-20230412023E.



This certificate of conformity is based on a single evaluation of the submitted sample(s) of the above mentioned product. It does not imply an assessment of the whole product and relevant. Without the written approval, it is not permitted to use the test lab's logo.

Shenzhen DL Testing Technology Co., Ltd.
101-201, Building C, Shuanghuan, No.8, Baoqing Road, Baoqing Industrial Zone, Baoqing Street, Longgang District, Shenzhen, Guangdong, China

Web: www.dl-test.com E-mail: Service@dl-test.com Tel: 400-686-3532



CERTIFICATE

of Conformity
Low Voltage Directive 2014/35/EU

Registration No.: AN 50489215 0001
Report No.: 60387434 001

Holder: SHENZHEN BOYAXUAN TECHNOLOGY DEVELOPMENT CO., LTD.
3/F, 1st Building, Xing Wei (Feng Huang) Third Industrial Area, Fuyong Street, Shenzhen 518100 Guangdong P.R. China

Product: Power Supply (AC/DC ADAPTER)

Identification: Type Designation: BYX2-XXXXYYF, BYX3-XXXXYYZ (BOYAXUAN)
For detail of the variables XXX, YYYY and Z refer to TÜV Rheinland license S 50489196 pages 0001-0002.
Serial No.: N.A.
Remark: Issued in conjunction with above TÜV Rheinland license.

This certificate of conformity is based on an evaluation of a sample of the above mentioned product. Technical Report and documentation are at the Licence Holder's disposal. This is to certify that the tested sample is in conformity with Annex 1 of Council Directive 2014/35/EU, referred to as the Low Voltage Directive. This certificate does not imply assessment of the series-production of the product and does not permit the use of a TÜV Rheinland mark of conformity. The holder of the certificate is authorized to use this certificate in connection with the EC declaration of conformity according to Annex IV of the Directive.



Certification Body

Date 25.01.2021

Dipl.-Ing. Univ. H. O. Steinko

TÜV Rheinland LGA Products GmbH - Tillystraße 2 - 90431 Nürnberg

CE The CE marking may be used if all relevant and effective EC Directives are complied with. CE



CERTIFICATE OF CONFORMITY

Electromagnetic Compatibility (EMC) Directive 2014/30/EU

This Certificate of Conformity is hereby issued to the product designated below:

Certificate No.: 23EP08001E01
Report No.: EP2308001E01
Date Issue: 2023-08-23
Applicant's name: Shenzhen MingFuXin Furniture Electrical Appliances Co., Ltd.
Address: 4 F, building a, No. 8, Chenwu Road, Dakang community, Yuanshan street, Longgang District, Shenzhen
Manufacturer's name: Shenzhen MingFuXin Furniture Electrical Appliances Co., Ltd.
Address: 4 F, building a, No. 8, Chenwu Road, Dakang community, Yuanshan street, Longgang District, Shenzhen
Product Description: Socket
Model(s)/Type References: OAZ-XXXX (The 1st "X" represents the switch, 0-1, the 2nd "X" represents the number of sockets 1-4, the 3th "X" represents the number of USB 1-3 (1 is double A, 2 is A+C, 3 is double C), and the 4th "X" represents the wireless charge 0-1)
Parameters: See attachment for details
Standard(s): EN 55032:2015+A11:2020+A1:2020, EN 55035:2017+A11:2020, EN IEC 61000-3-2:2019+A1:2021, EN 61000-3-3:2013+A1:2019+A2:2021

On the basis of the referenced test report(s), sample(s) tested of the above product have been found to comply with the standards harmonized with the directives listed on this verification at the time the tests were carried out. Other standards and Directives may be relevant to the product. This verification is part of the full test report(s) and should be read in conjunction with it(them).

Once compliance with all product relevant CE mark directives are verified, including any relevant e.g. risk assessment and production control, the manufacturer may indicate compliance by signing a Declaration of Conformity themselves and applying the mark to products identical to the tested sample(s).

Approved By

Eric Liu
Director of engineering department

Dongguan Pubiao Testing Technology Co., Ltd
No. 3, 1/F., Building A, No.30, Minghua Road, Juzhou, Shijie, Dongguan, Guangdong, China
Tel: +86 769 81813516 E-mail: service@pubiaotest.com Web: www.pubiaotest.com



CERTIFICATE OF CONFORMITY

Electromagnetic Compatibility (EMC) Directive 2014/30/EU

Appendix of Certificate No.: 23EP08001E01

Parameters:
 Input: 220-250Vac, 50Hz, 10A
 Output: AC socket: 2500W max
 1) For USB A+Type-C output:
 Type-C: 5VDC3A/9VDC2.22A/12VDC1.67A
 USB A: 5VDC3A/9VDC2A/12VDC1.5A
 Type-C&USB: 5VDC/3A
 Wireless: 15W max
 2) For double C output:
 Type-C1: 5VDC3A/9VDC2.22A/12VDC1.67A
 Type-C2: 5VDC3A/9VDC2A/12VDC1.5A
 Type-C1&Type-C2: 5VDC/3A
 Wireless: 15W max
 3) For double A output:
 USB A1: 5VDC 2.1A
 USB A2: 5VDC 2.1A
 USB A1&USB A2: 5VDC/2.1A
 Wireless: 15W max



Dongguan Pubiao Testing Technology Co., Ltd
No. 3, 1/F., Building A, No.30, Minghua Road, Juzhou, Shijie, Dongguan, Guangdong, China
Tel: +86 769 81813516 E-mail: service@pubiaotest.com Web: www.pubiaotest.com