

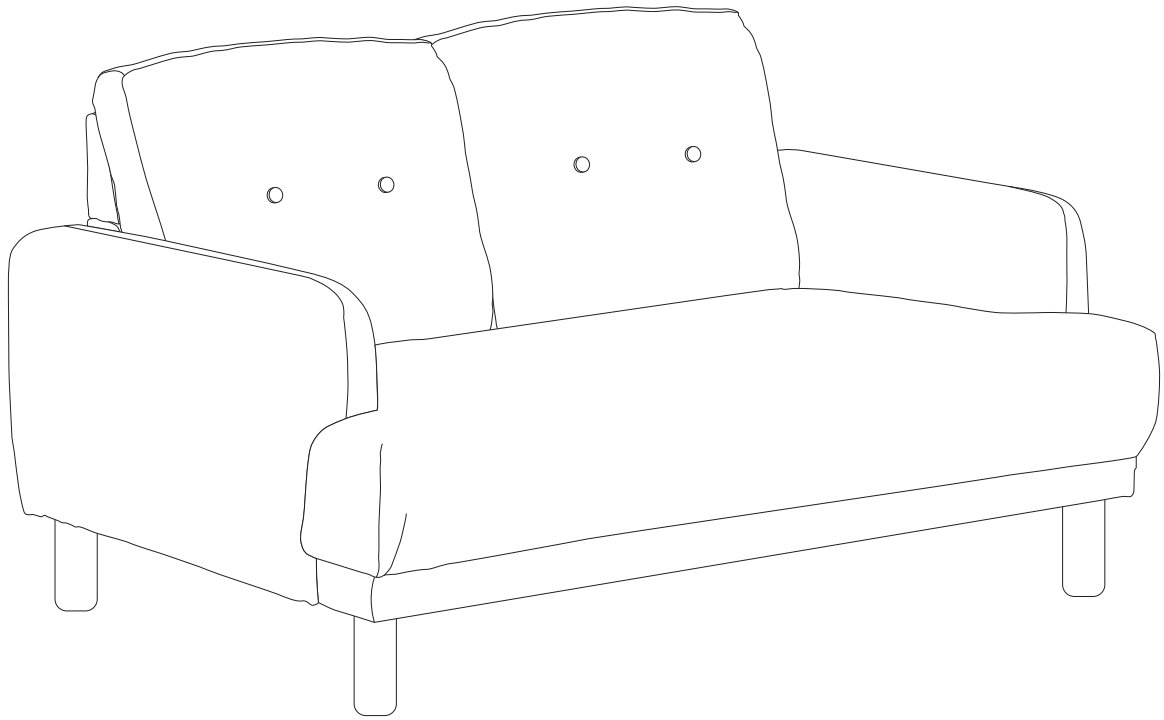

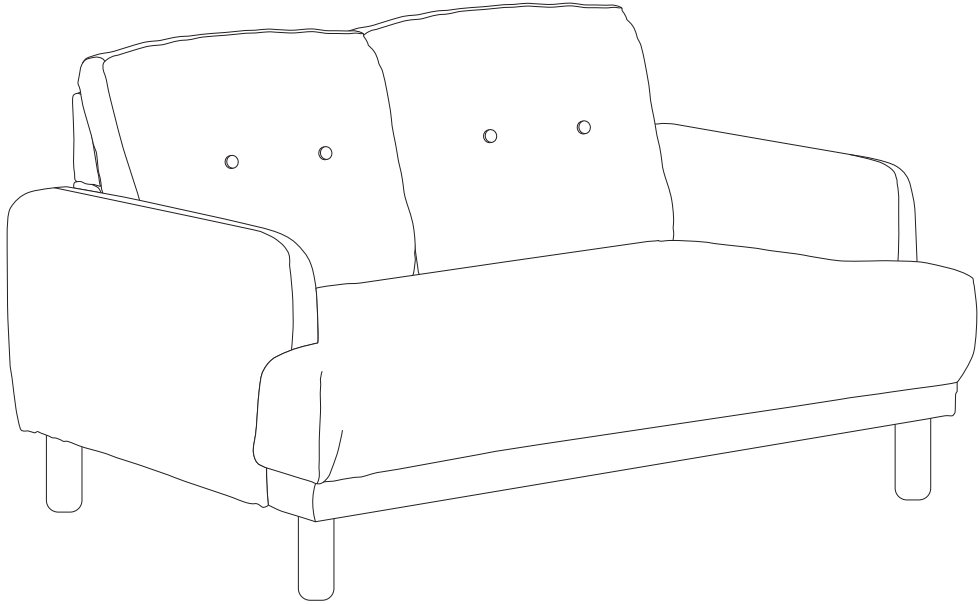

# TUVE

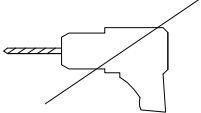

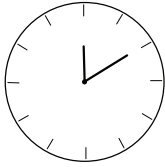
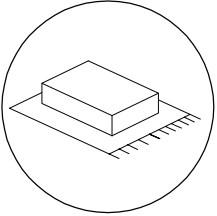

		
		10'
		
		2

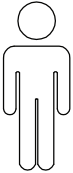
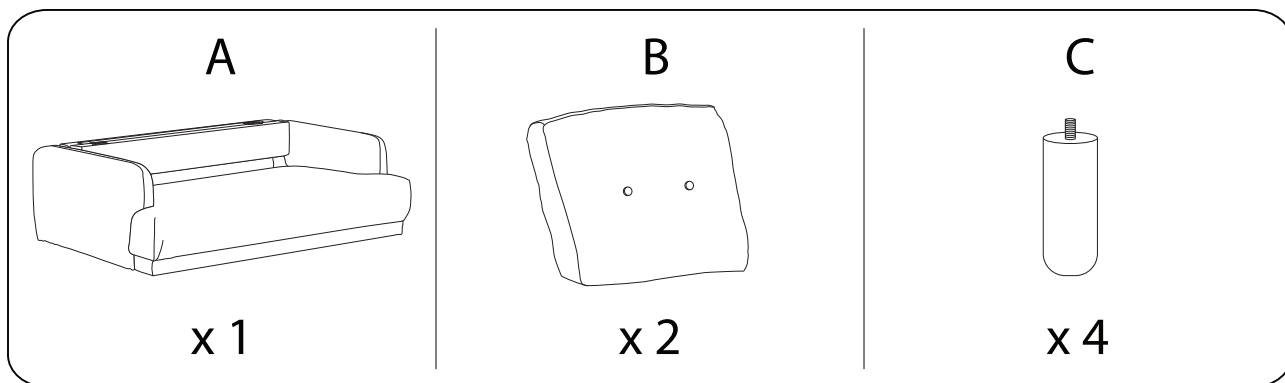
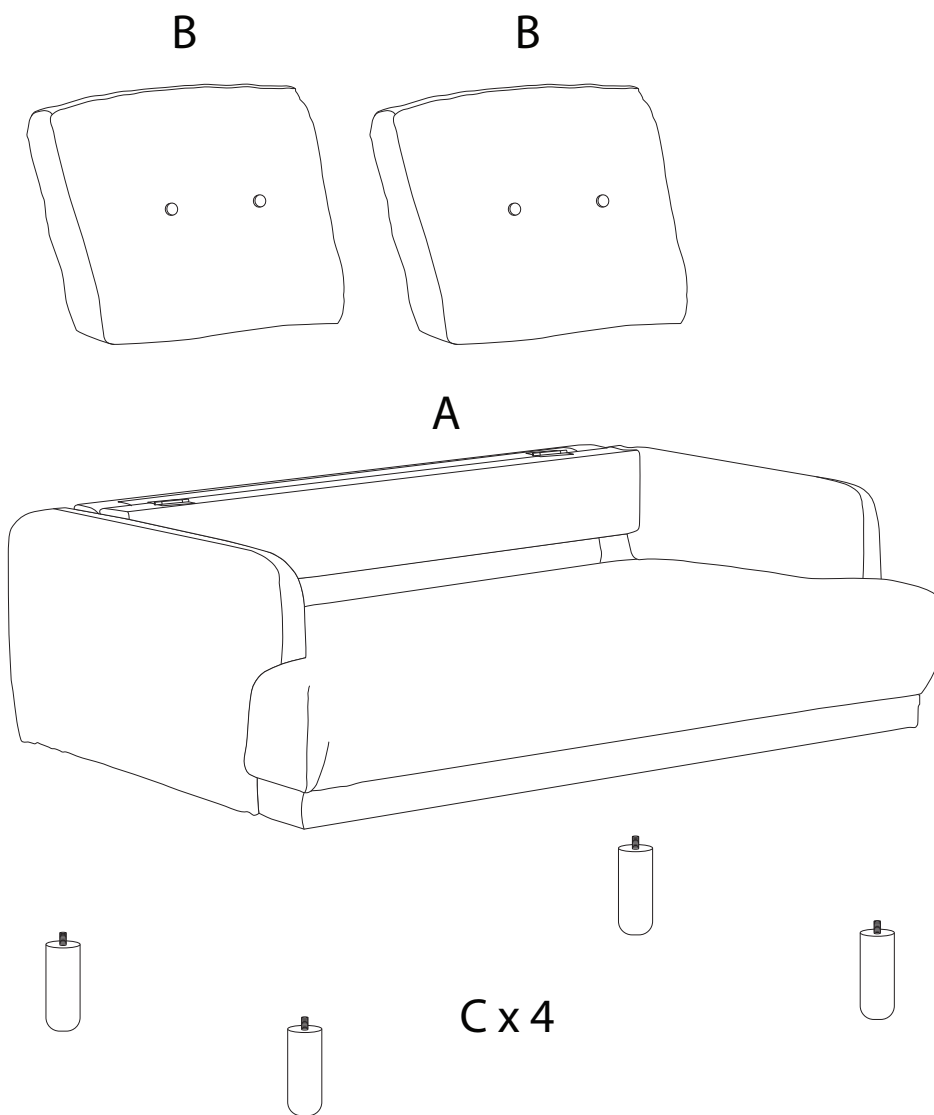

!

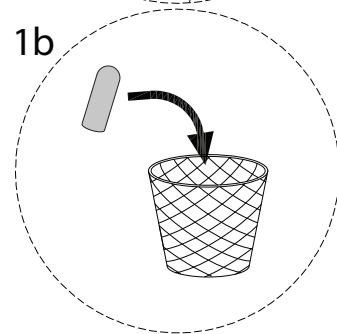
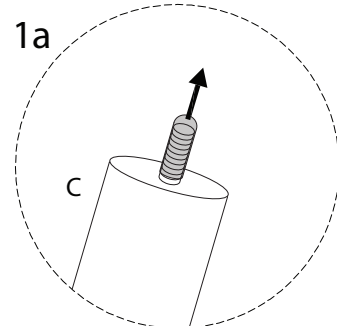
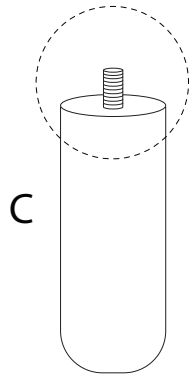

1

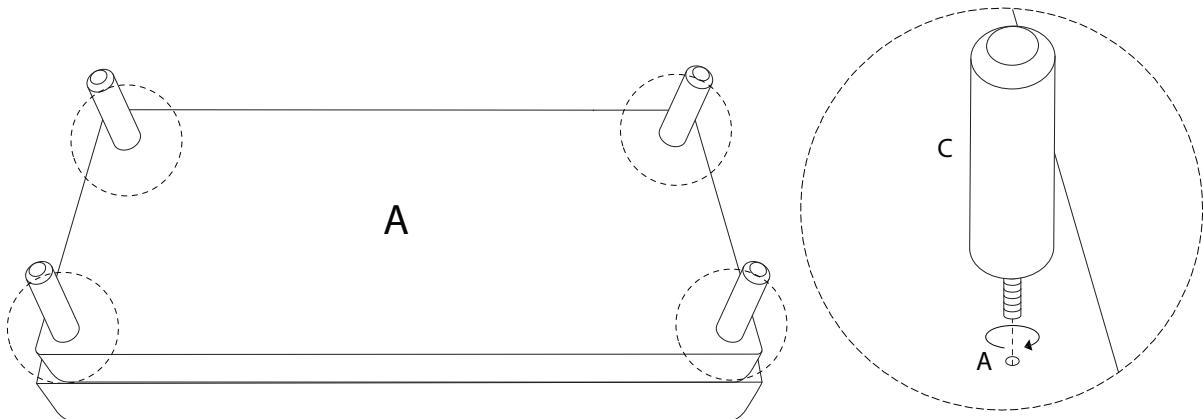
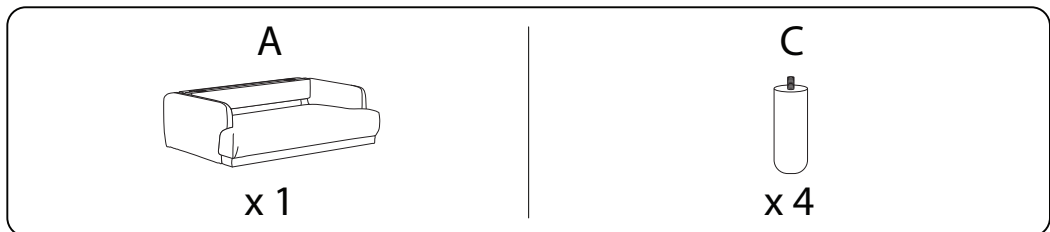

2

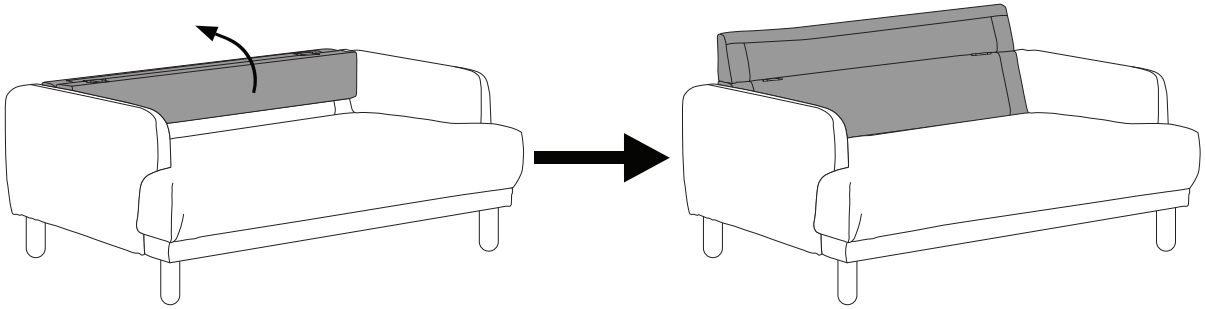

3

