

Montageanleitung | Instructions de montage

Assembly Instructions | Instrucciones de montaje

SKU NUMBER: N616P333020G

N616P333021G

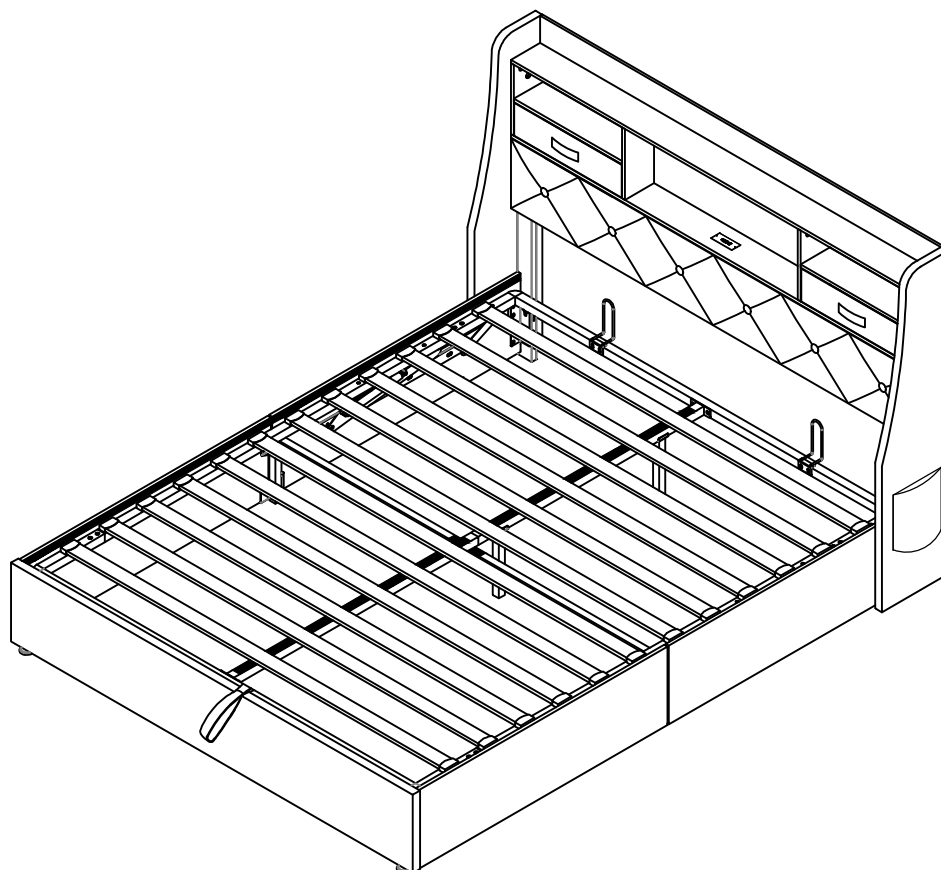

GB This set comes in 2 boxes. If you do not receive a full set of 2 boxes, please contact our customer service.

DE Dieses Set wird in 2 Schachteln geliefert. Wenn Sie nicht ein komplettes Set von 2 Boxen erhalten, kontaktieren Sie bitte unseren Kundenservice.

FR Ce set est livré en 2 boîtes. Si vous ne recevez pas un jeu complet de 2 boîtes, veuillez contacter notre service clientèle.

English

IMPORTANT FOR GAS LIFT BEDS&MAINTAINCE

- Please place the mattress on top of the bed frame.
- Please do not pull on the strap handles.
- Please press heavily to release the compressed gas.
- Periodically check all screw & fixings to ensure they are secure.
- When moving your product, carefully lift into place.
- Wipe clean with a slightly damp cloth- please do not use abrasive chemicals or bleach.
- Do NOT allow children to operate the lift mechanism.
- Do NOT allow children near the lift base when operating the mechanism.
- Do NOT stand inside the bed or the internal storage base.
- Do NOT overload the internal storage base.
- DO NOT jump on the product or any of its parts.

Deutsch

WICHTIG FÜR GASLIFT-BETTEN&WARTUNG

- Bitte legen Sie die Matratze oben auf den Bettrahmen.
- Bitte ziehen Sie nicht an den Gurtgriffen.
- Bitte drücken Sie kräftig, um das komprimierte Gas freizusetzen.
- Überprüfen Sie regelmäßig alle Schrauben und Befestigungen, um sicherzustellen, dass sie sicher sind.
- Wenn Sie Ihr Produkt bewegen, heben Sie es vorsichtig an seinen Platz.
- Mit einem leicht feuchten Tuch abwischen - bitte keine scheuernden Chemikalien oder Bleichmittel verwenden.
- Erlauben Sie Kindern NICHT, den Hebemechanismus zu bedienen.
- Lassen Sie Kinder NICHT in die Nähe des Liftsockels, wenn Sie den Mechanismus bedienen.
- Stellen Sie sich NICHT in das Bett oder in die Innenablage.
- Überlasten Sie den internen Liftsockel NICHT.
- Springen Sie NICHT auf das Produkt oder eines seiner Teile.

Français

IMPORTANT POUR LES LITS À RELEVAGE DE GAZ&MAINTENANCE

- Veuillez placer le matelas sur le dessus du cadre de lit.
- Ne tirez pas sur les poignées de la sangle.
- Appuyez fortement pour libérer le gaz comprimé.
- Vérifiez régulièrement que toutes les vis et fixations sont bien en place.
- Lorsque vous déplacez votre produit, soulevez-le avec précaution pour le mettre en place.
- Nettoyez avec un chiffon légèrement humide - n'utilisez pas de produits chimiques abrasifs ou d'eau de Javel.
- Ne laissez pas les enfants utiliser le mécanisme de levage.
- Ne laissez pas les enfants s'approcher de la base de levage lorsqu'ils actionnent le mécanisme.
- Ne vous tenez PAS à l'intérieur du lit ou de la base de stockage interne.
- Ne surchargez pas la base de stockage interne.
- Ne pas sauter sur le produit ou l'une de ses parties.

Italiano

IMPORTANTE PER I LETTI CON SOLLEVAMENTO A GAS E LA MANUTENZIONE

- Posizionare il materasso sopra la struttura del letto.
- Non tirare le maniglie della cinghia.
- Premere con forza per rilasciare il gas compresso.
- Controllare periodicamente tutte le viti e i fissaggi per assicurarsi che siano saldi.
- Quando si sposta il prodotto, sollevarlo con cautela.
- Pulire con un panno leggermente umido, senza usare prodotti chimici abrasivi o candeggina.
- NON permettere ai bambini di azionare il meccanismo di sollevamento.
- NON permettere ai bambini di avvicinarsi alla base di sollevamento quando si aziona il meccanismo.
- NON sostare all'interno del letto o della base di contenimento interna.
- NON sovraccaricare la base di contenimento interna.
- NON saltare sul prodotto o sulle sue parti.

Español

IMPORTANTE PARA LAS CAMAS ELEVADORAS DE GAS&MANTENIMIENTO

- Coloque el colchón sobre el somier.
- No tire de las asas de la correa.
- Presione con fuerza para liberar el gas comprimido.
- Compruebe periódicamente que todos los tornillos y fijaciones estén bien sujetos.
- Al mover el producto, levántelo con cuidado para colocarlo en su sitio.
- Limpie con un paño ligeramente humedecido; no utilice productos químicos abrasivos ni lejía.
- NO permita que los niños accionen el mecanismo de elevación.
- NO permita que los niños se acerquen a la base elevadora cuando accionen el mecanismo.
- NO se ponga de pie dentro de la cama o de la base de almacenamiento interna.
- NO sobrecargue el somier.
- NO salte sobre el producto ni sobre ninguna de sus piezas.

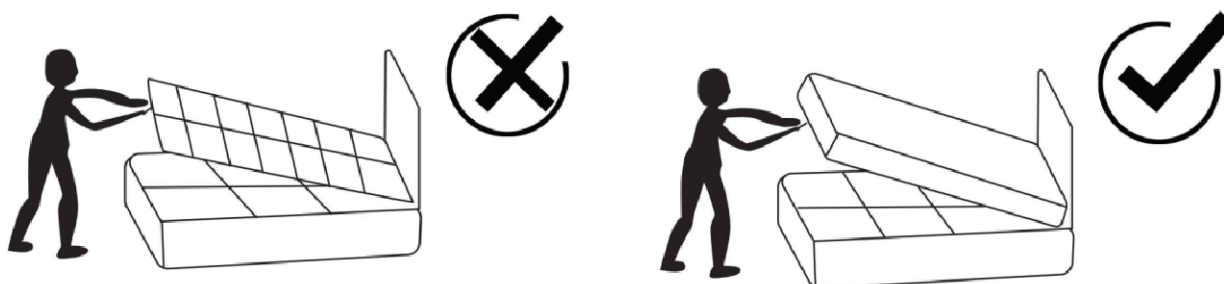

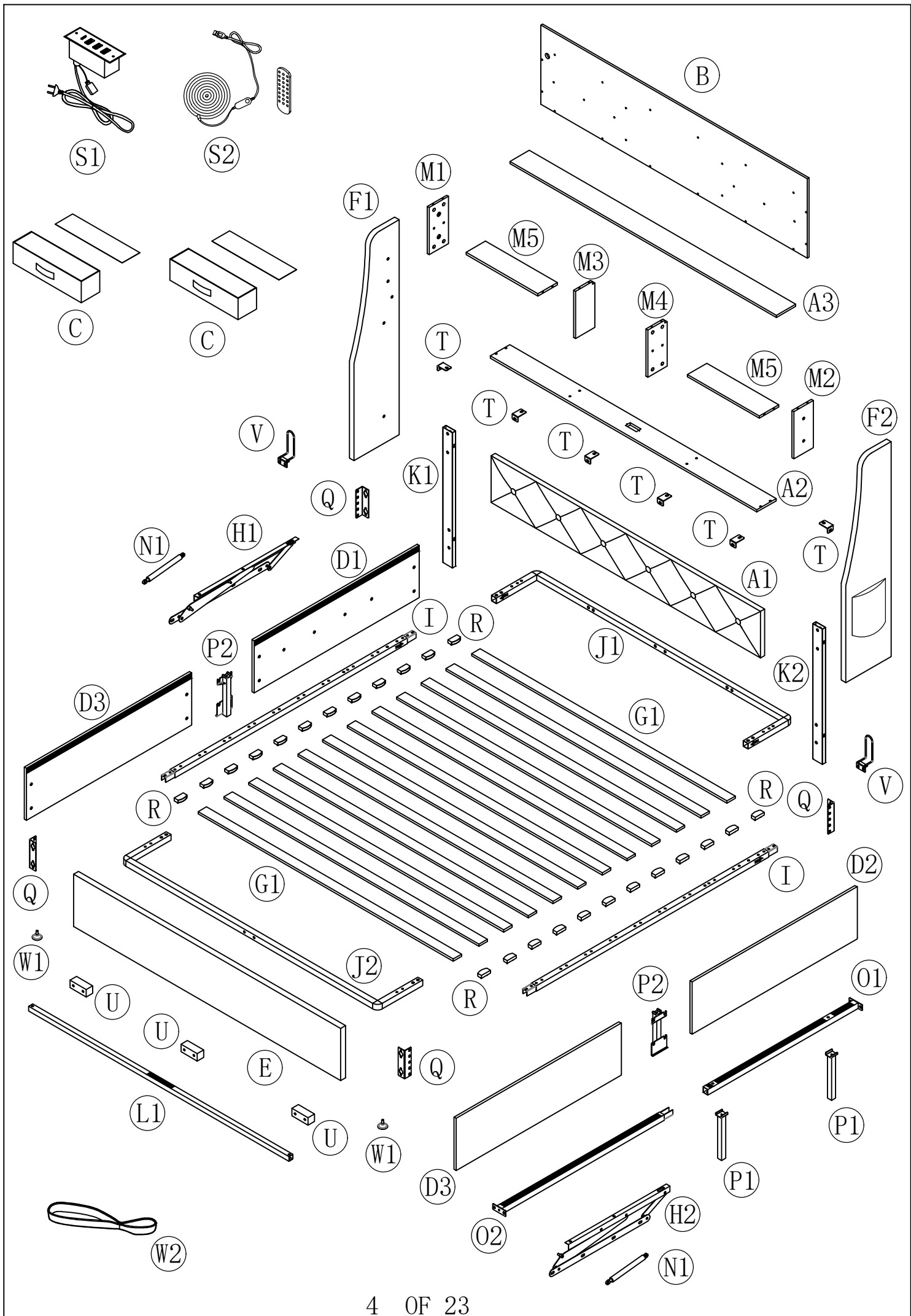

N616P333020G

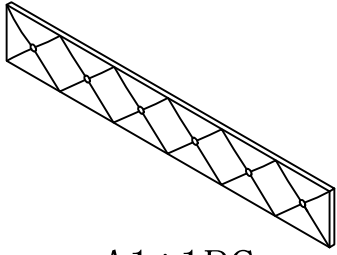

A1*1PC

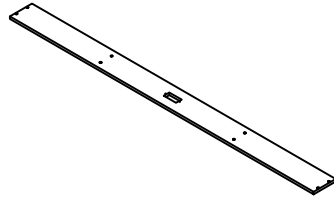

A2*1PC

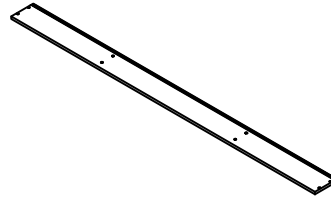

A3*1PC

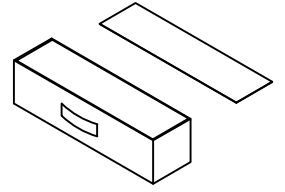

C*2PCS

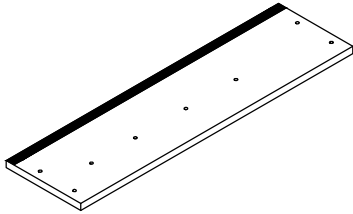

D1*1PC

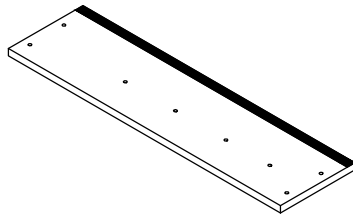

D2*1PC

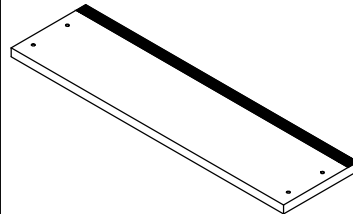

D3*2PCS



F1*1PC



F2*1PC

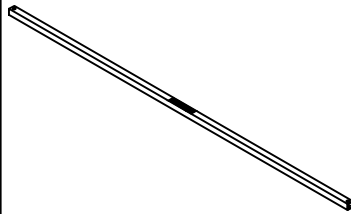

L1*1PC

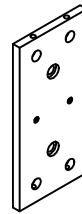

M1*1PC

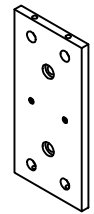

M2*1PC

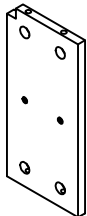

M3*1PC



M4*1PC

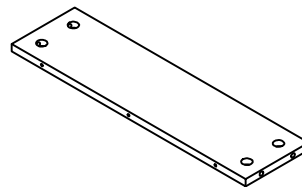

M5*2PCS

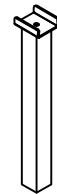

P1*2PCS

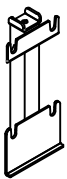

P2*2PCS

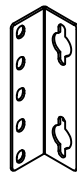

Q*4PCS

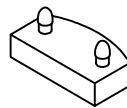

R*24PCS

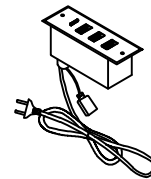

S1*1PC

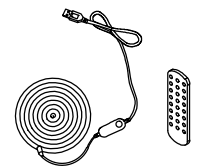

S2*1PC

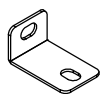

T*6PCS

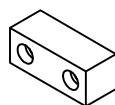

U*3PCS

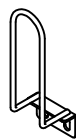

V*2PCS





W1*2PCS





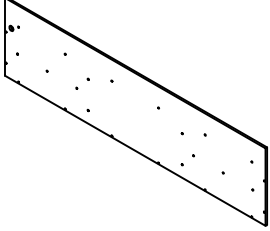
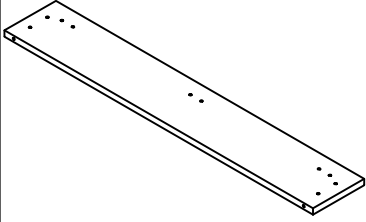
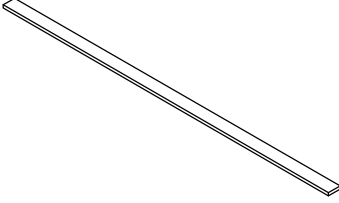
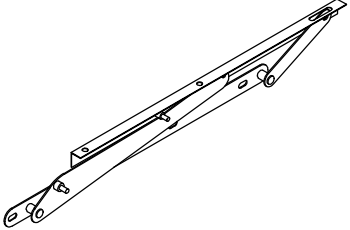
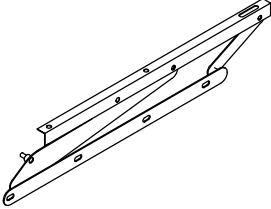
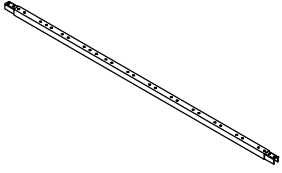
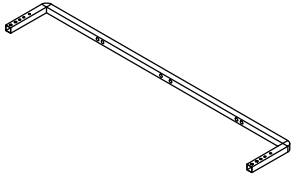
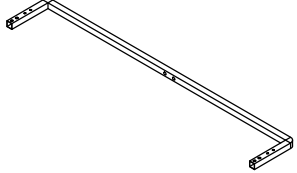

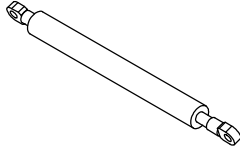
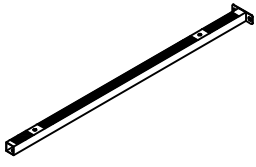
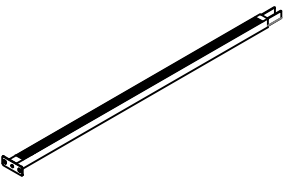

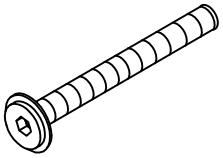
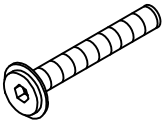
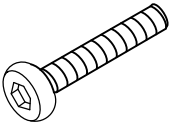
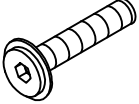
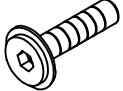

W2*1PC

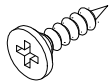
N616P333021G

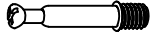
 B*1PC	 E*1PC	 G1*12PCS	 H1*1PC	
 H2*1PC	 I*2PCS	 J1*1PC	 J2*1PC	
 K1*1PC	 K2*1PC	 N1*2PCS	 O1*1PC	 O2*1PC

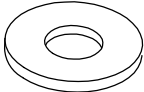
Hardware List-Hardwareliste N616P333020G

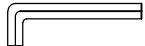
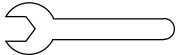
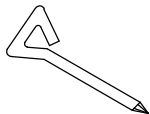
 M8*85MM X1*4PCS	 M8*50MM X2*6PCS	 M8*45MM X3*14PCS	 M8*30MM X4*16PCS	 M8*25MM X5*10PCS	 M8*16MM X6*34PCS
 M8*10MM X7*6PCS	 M3*15MM X8*2PCS	 M8 Y1*10PCS	 Ø6x35mm Y2*24PCS	 Ø15x10mm Y3*24PCS	 Ø5x40mm Y4*26PCS
 Ø22*Ø8.5 Z1*4PCS	 M3 Z2*1PC	 M5 Z3*1PC	 M13 Z4*1PC	 M5 Z5*1PC	

1

Y2*8

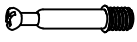

φ6x35mm

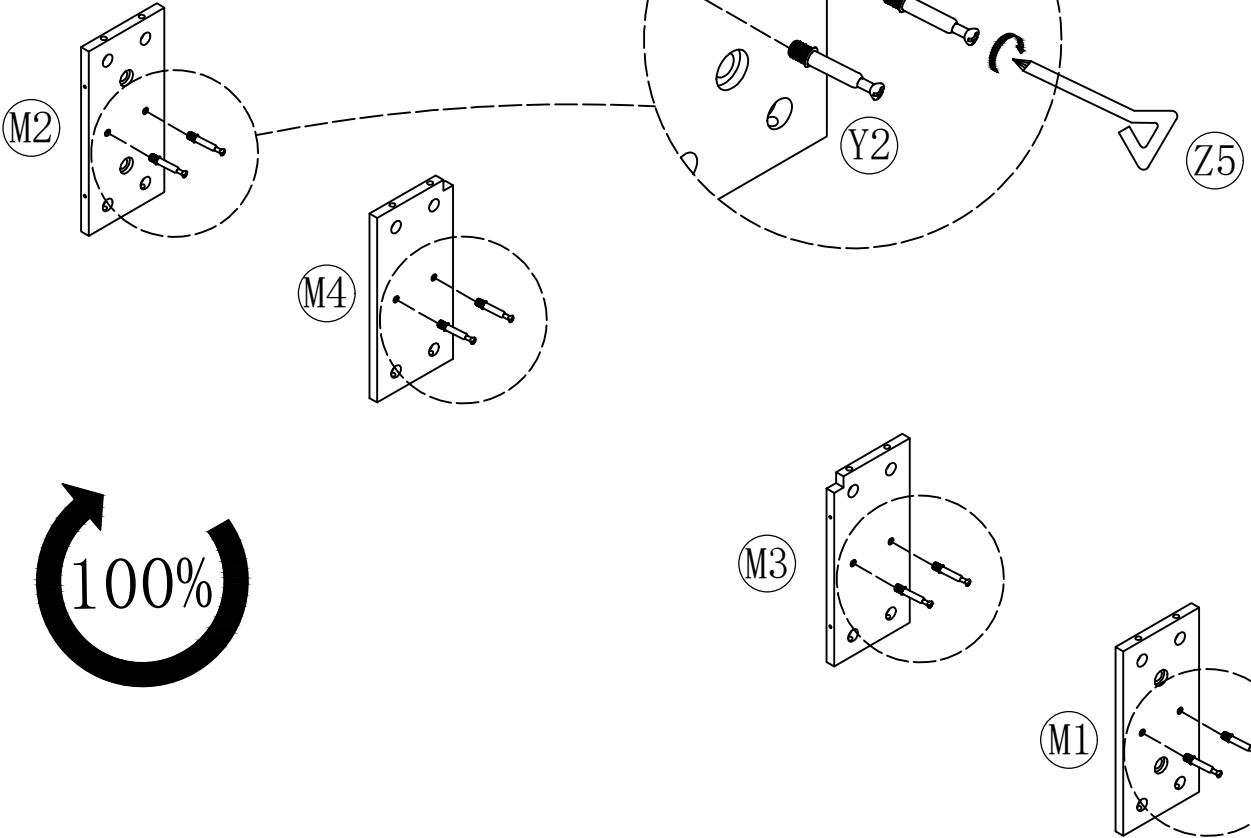

2

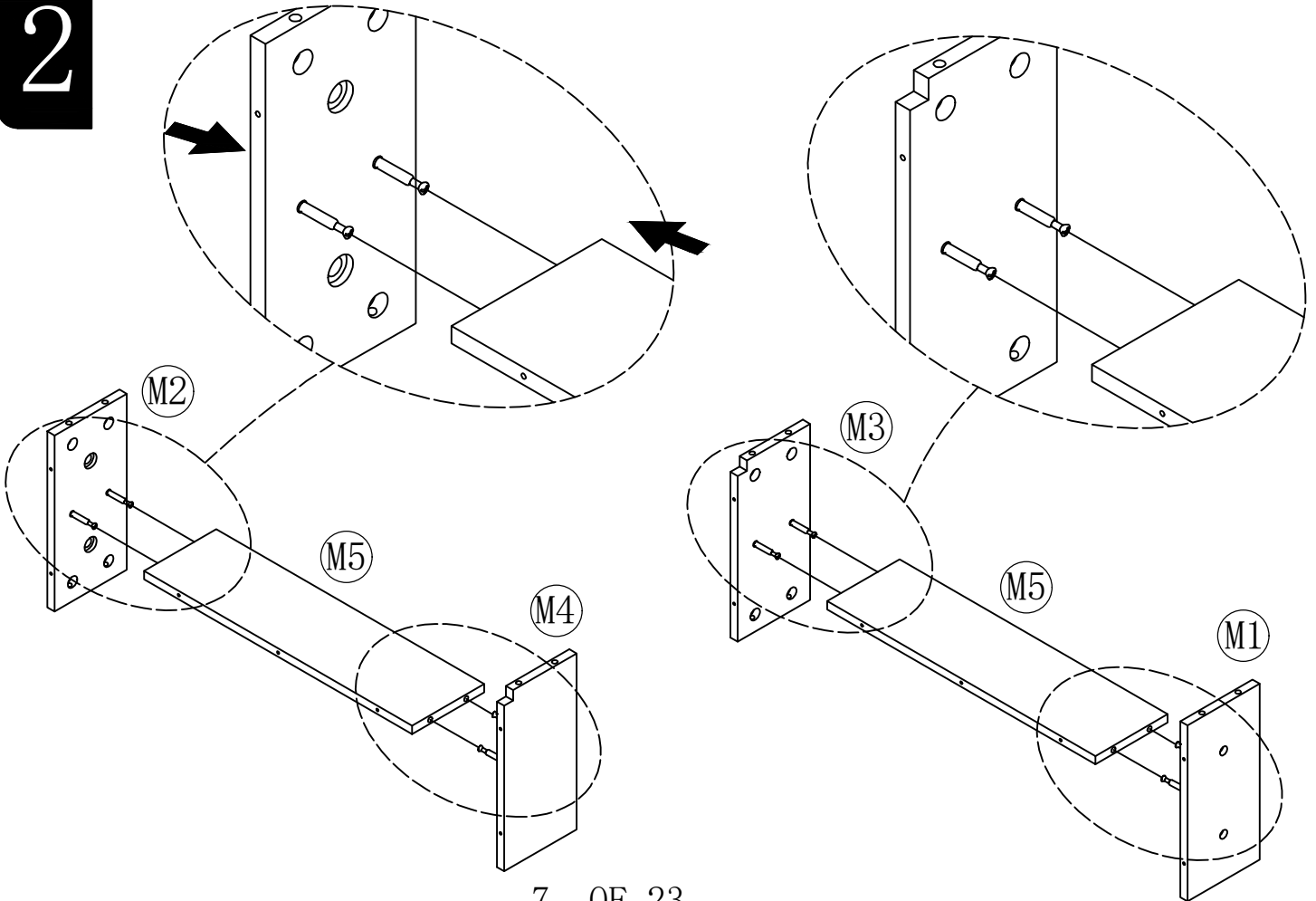

3

Y3*8



φ15x10mm

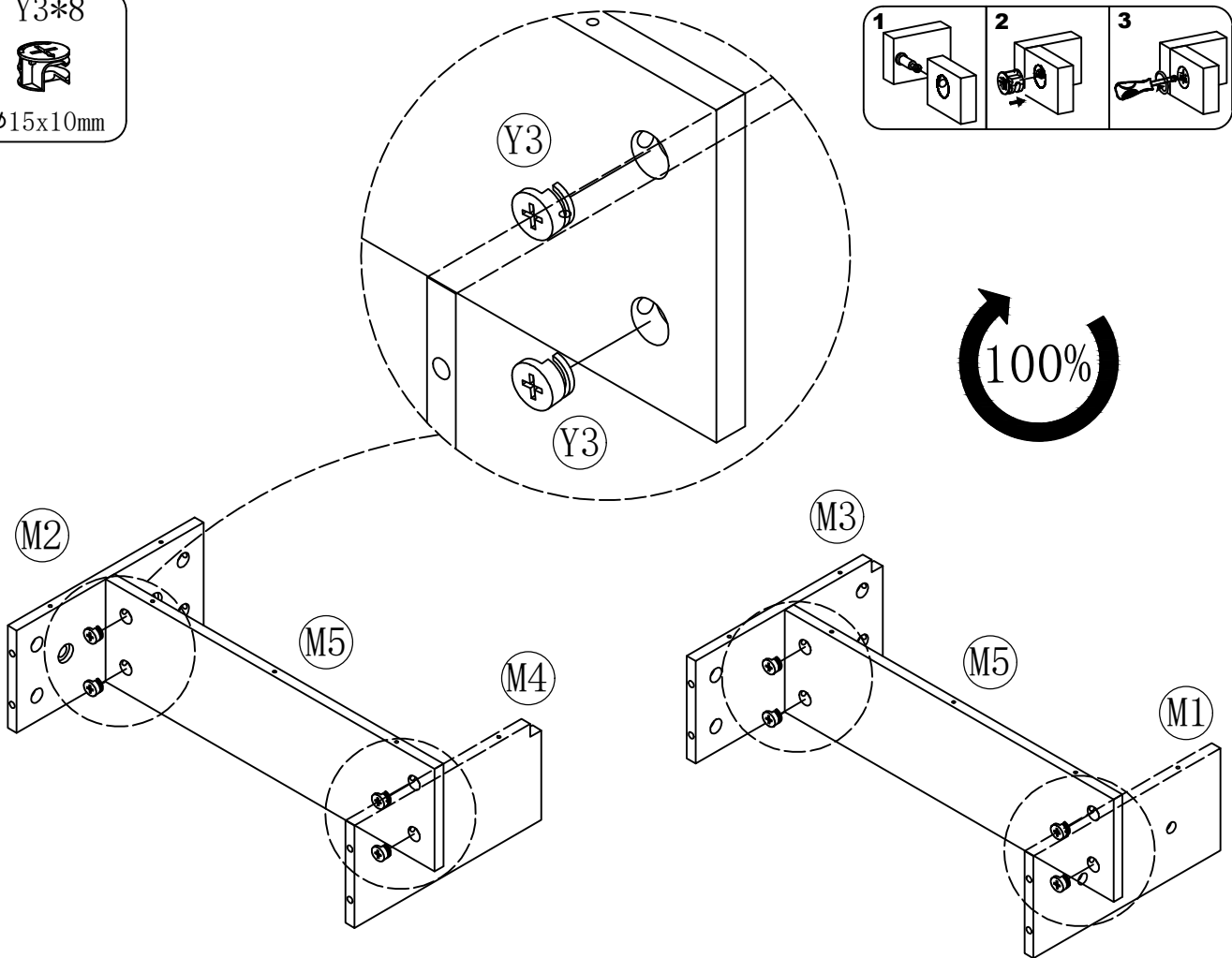
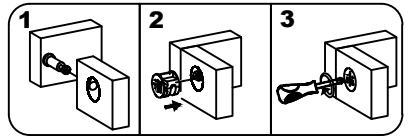

4

Y2*8

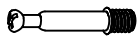

φ6x35mm

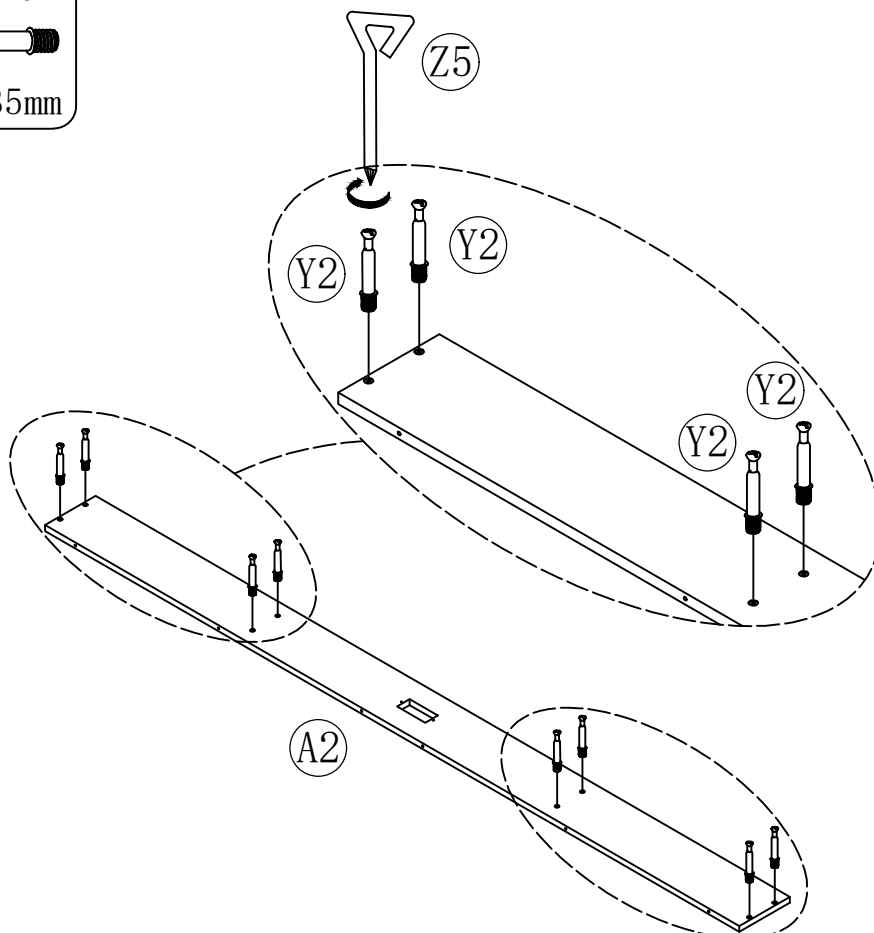

5

Y2*8
φ6x35mm

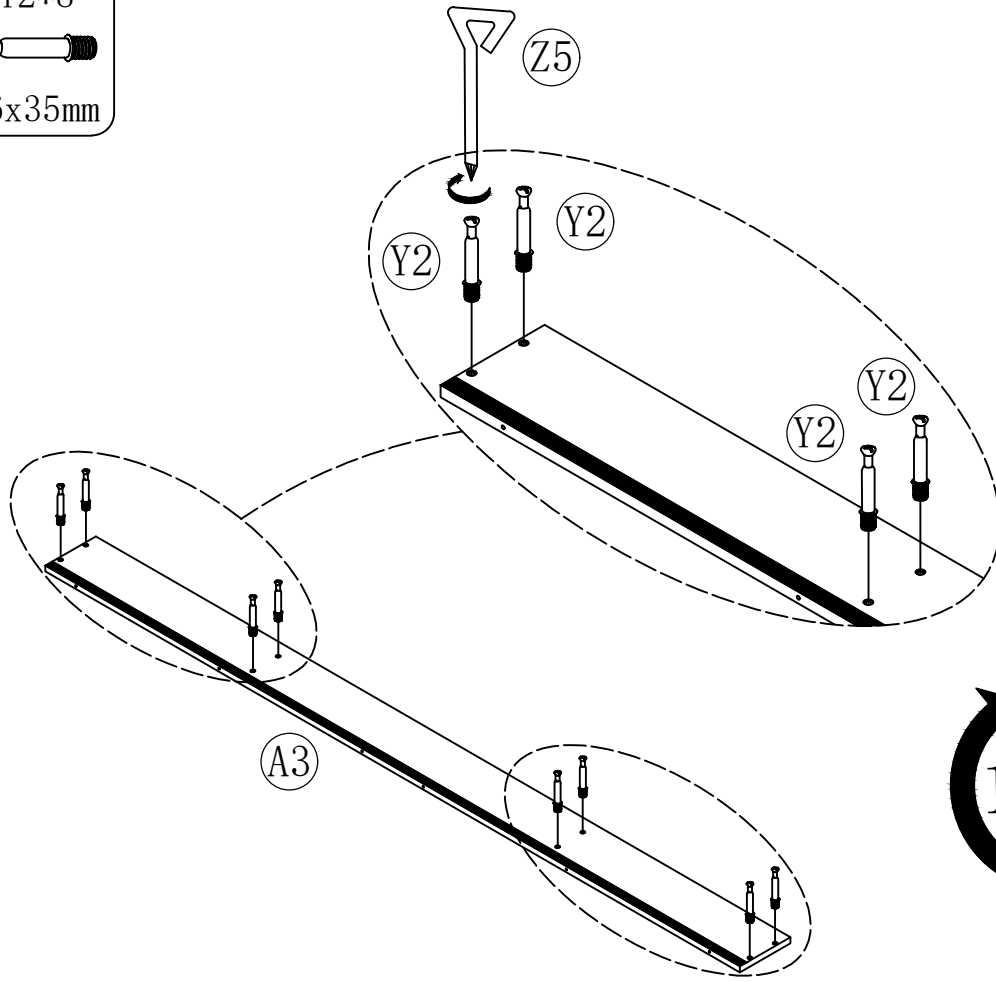

6

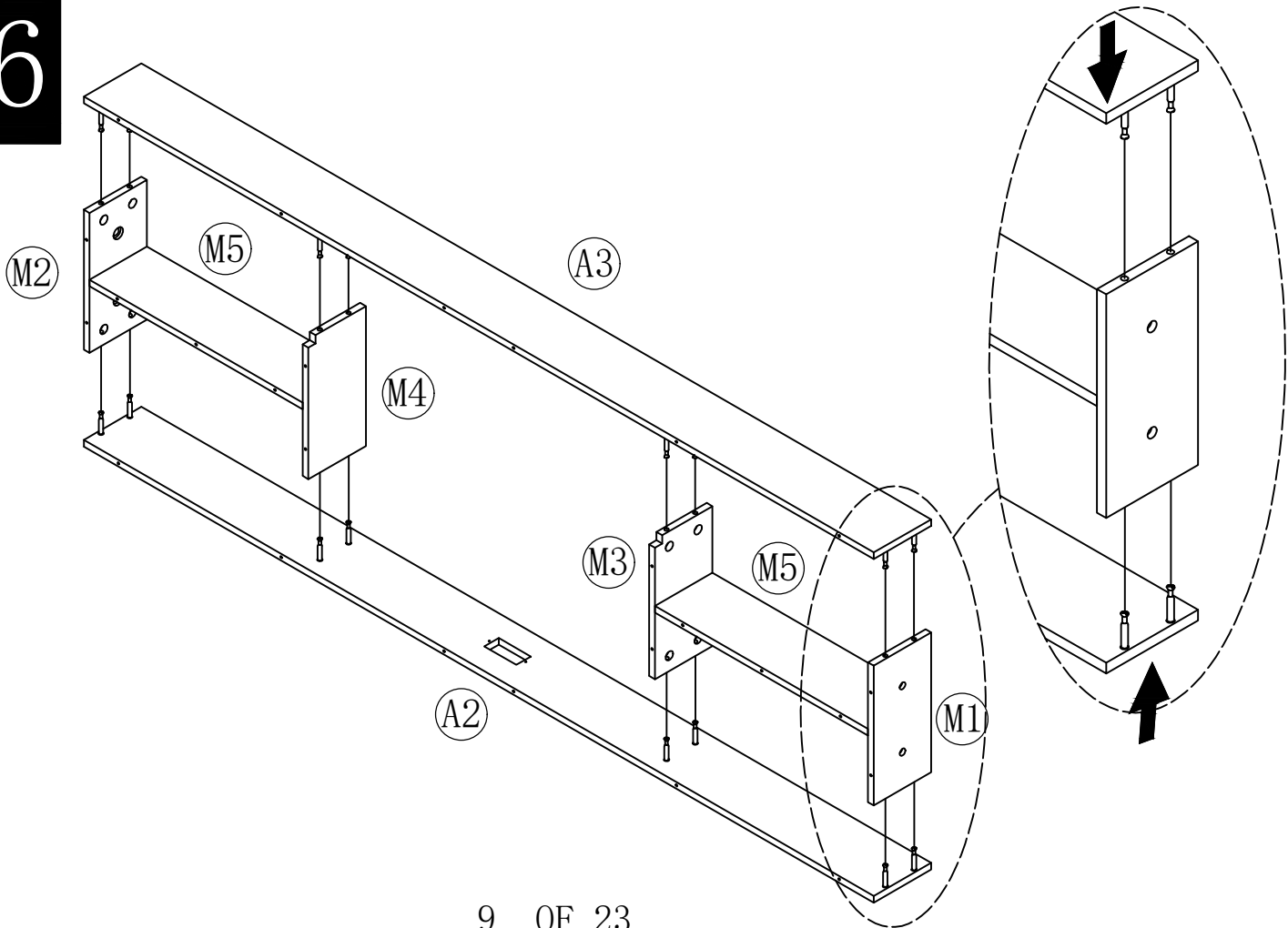

7

Y3*16



φ15x10mm

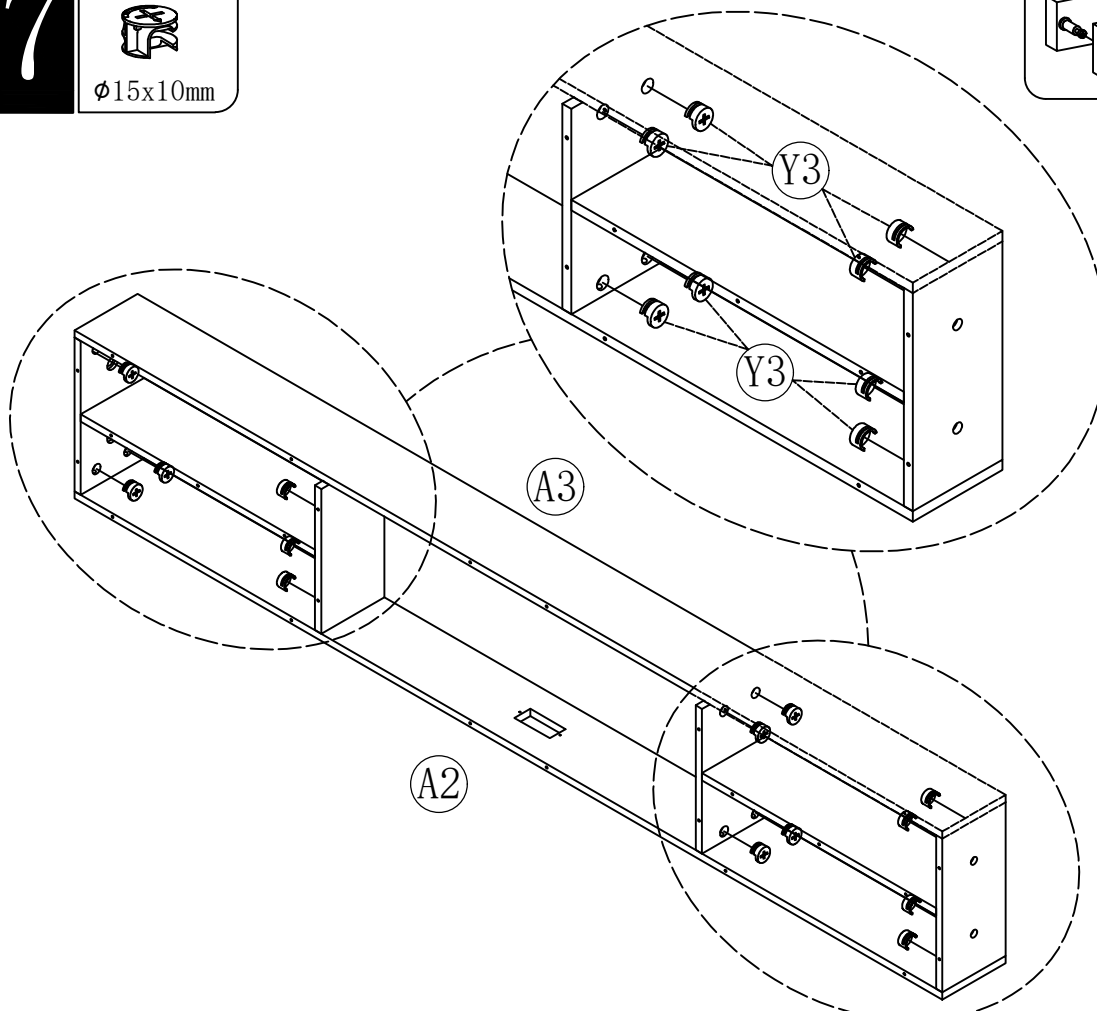
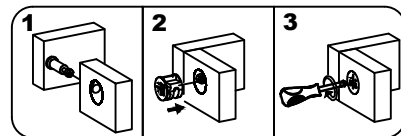

8

Y4*26



φ5x40mm

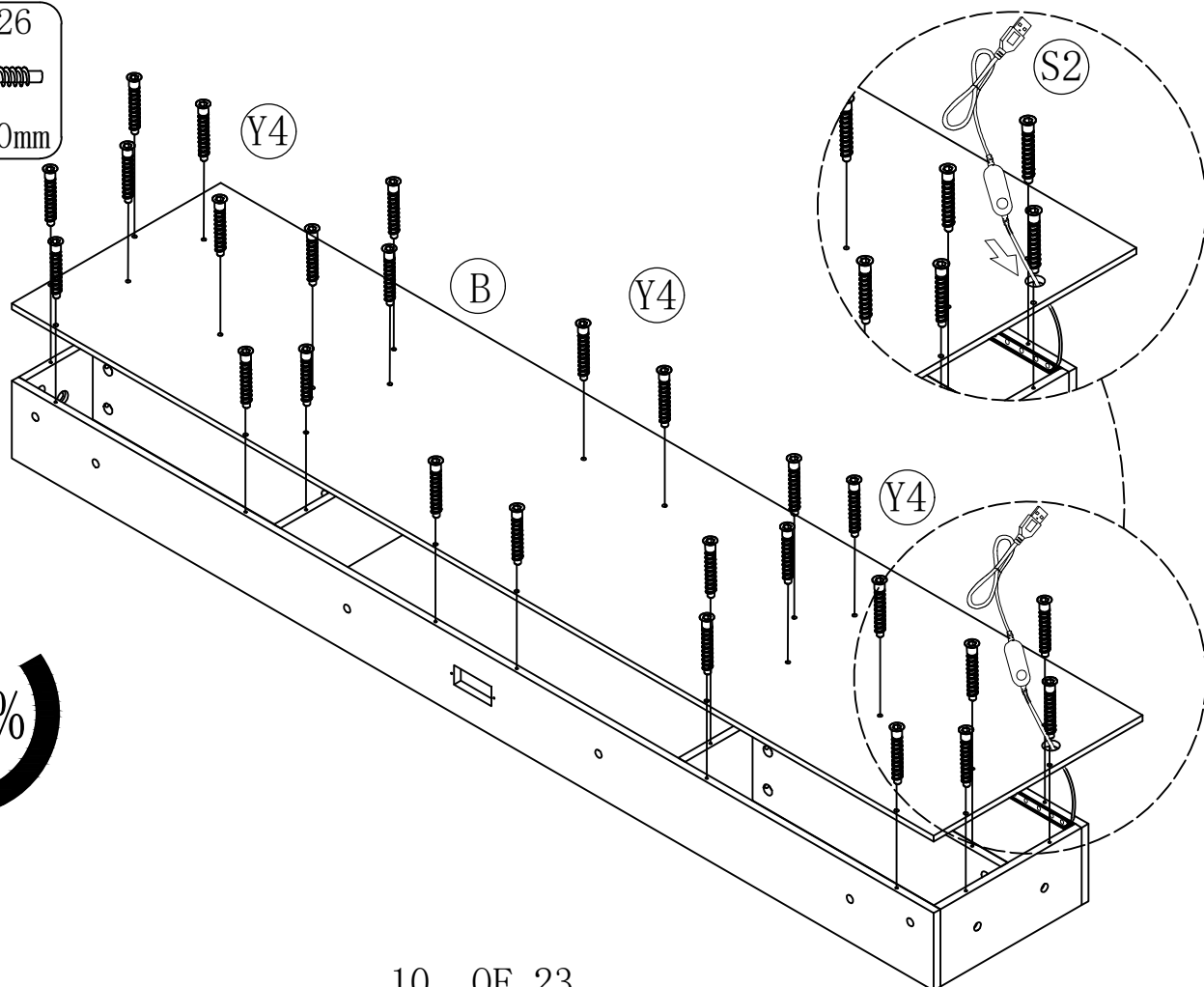

9

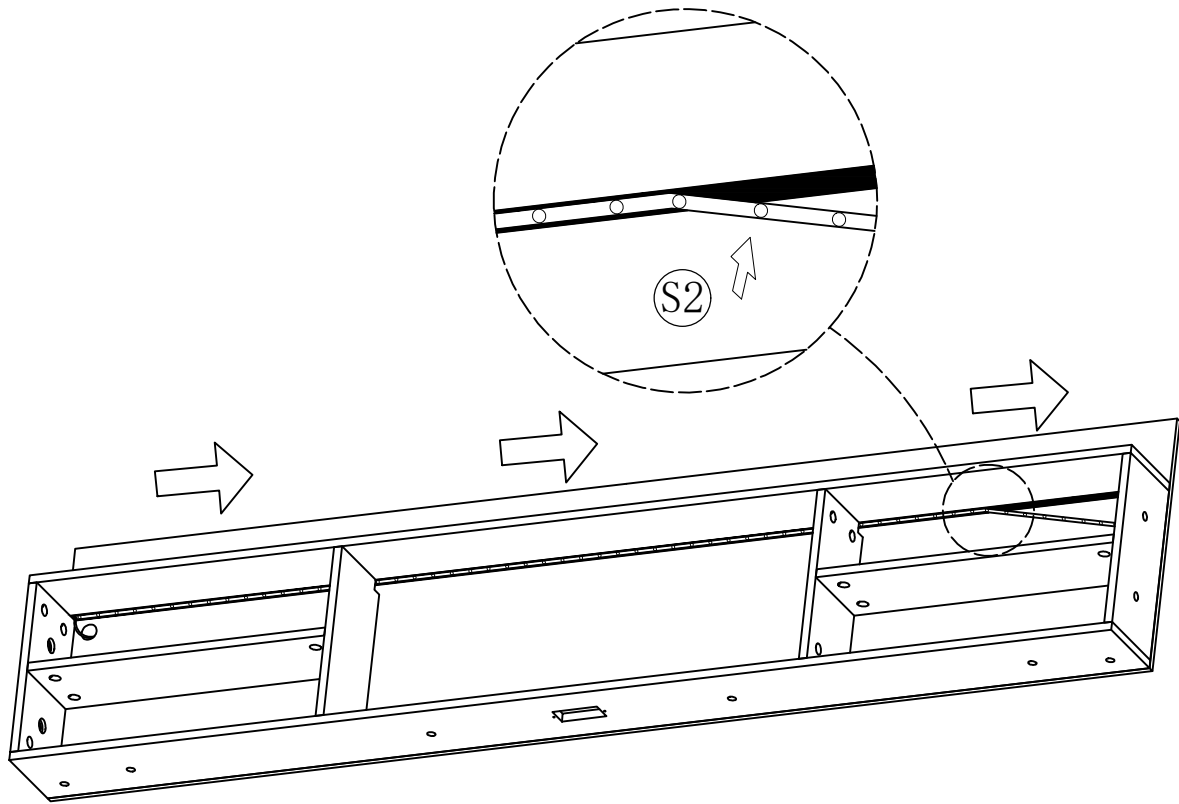

10

X3*4 M8*45mm	X5*4 M8*25mm	Z1*4 φ22*φ8.5
-----------------	-----------------	------------------

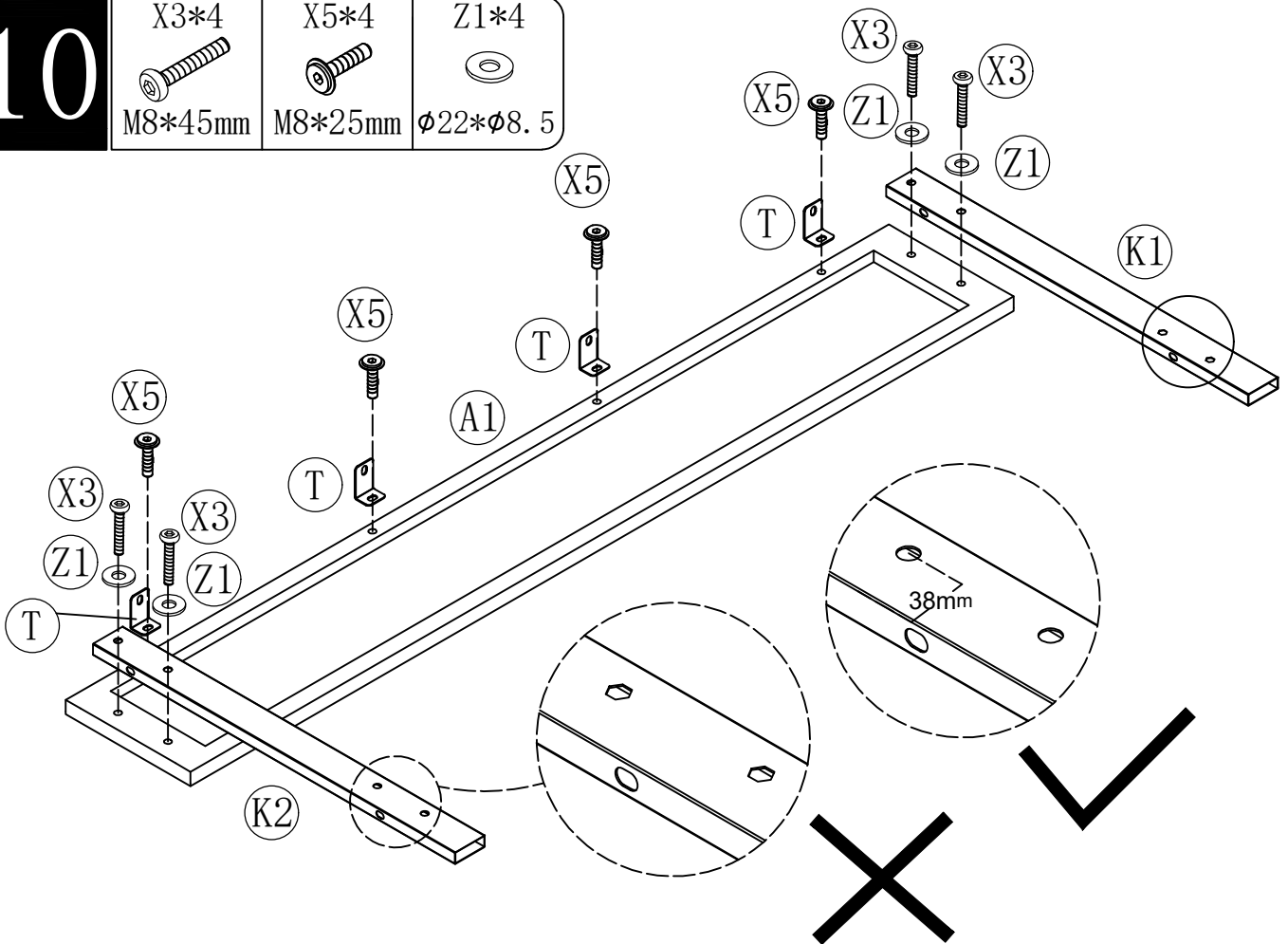

11

X6*8



M8*16mm

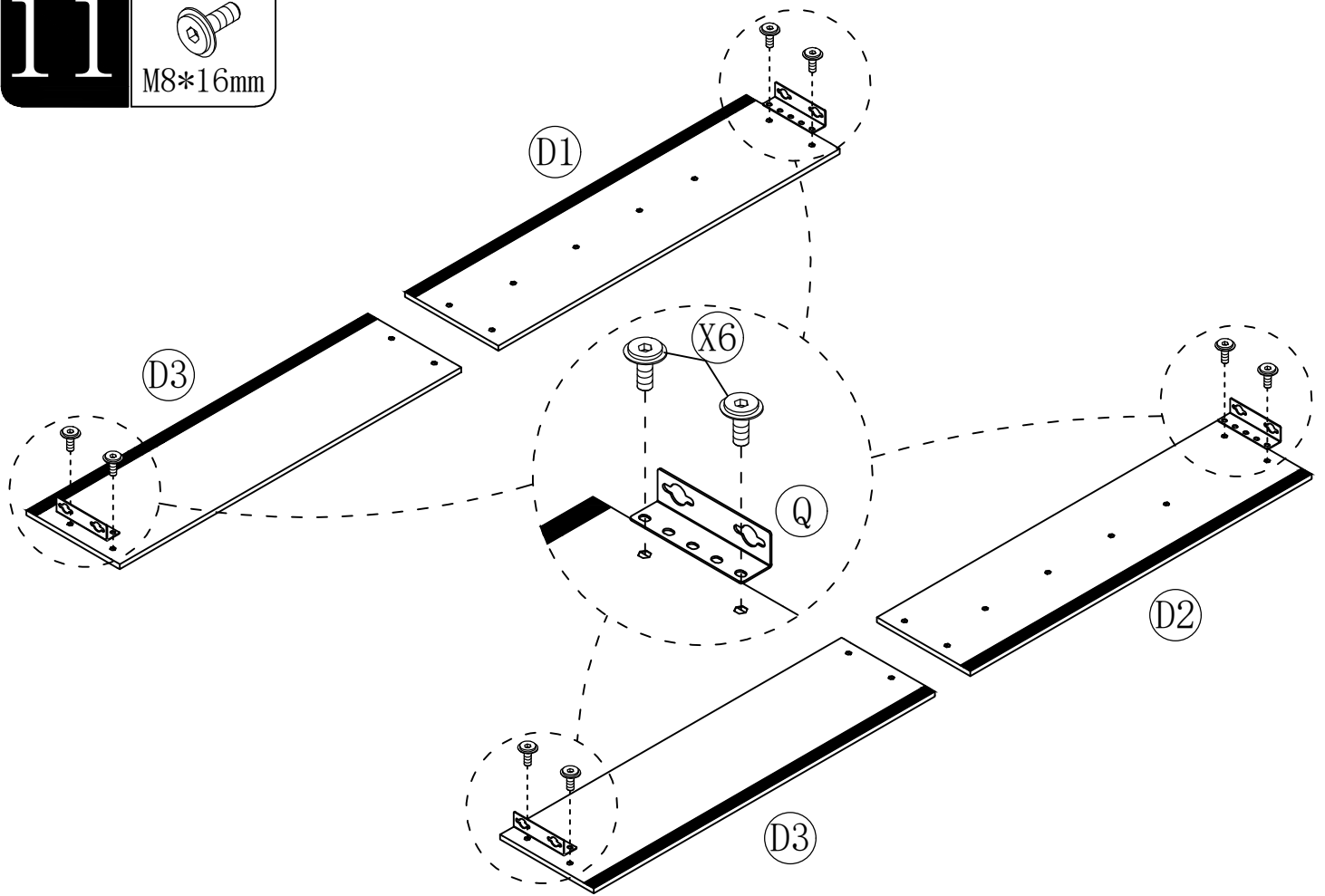

12

X6*8



M8*16mm

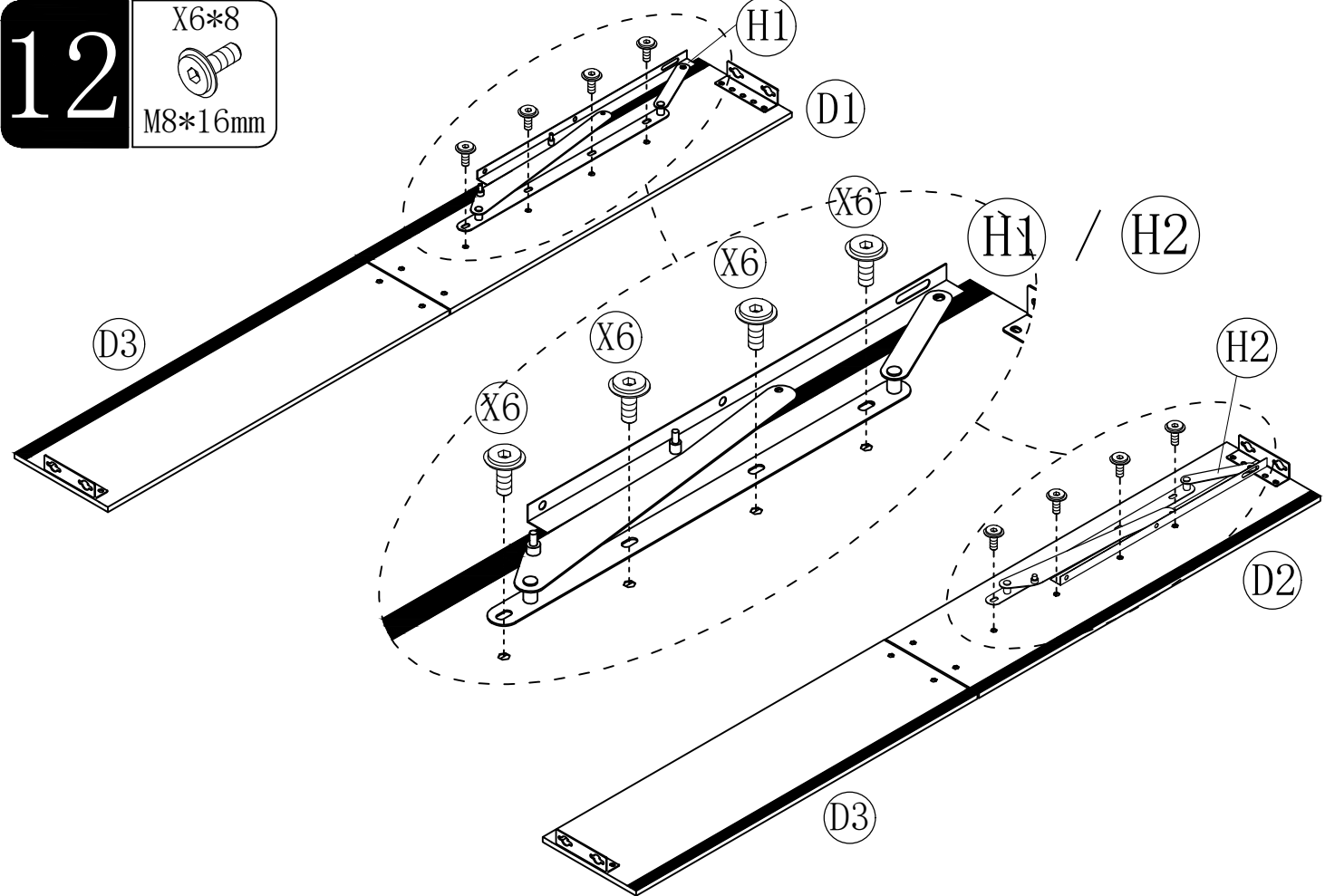

13

X6*8
M8*16mm

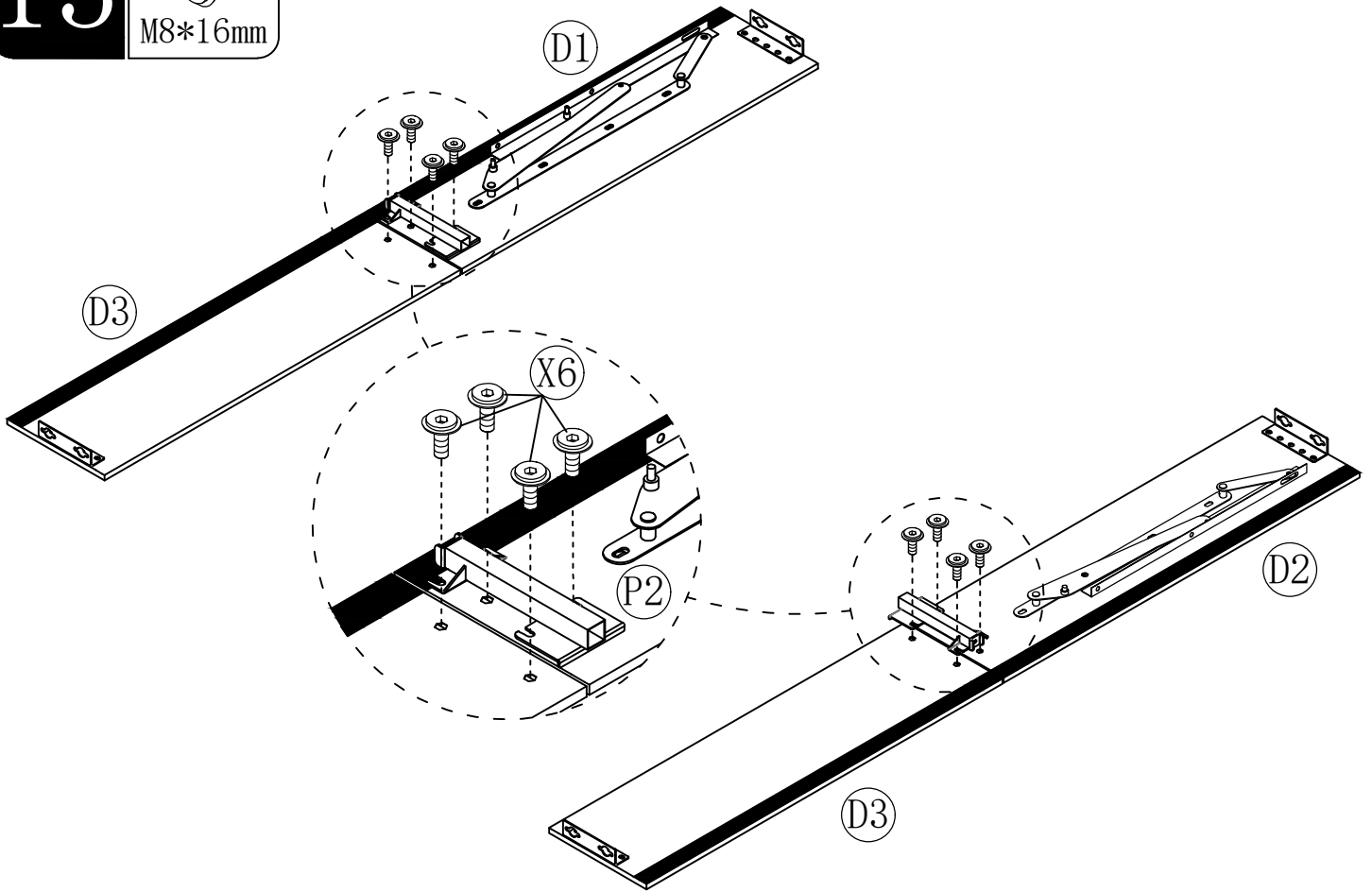

14

X4*4
M8*30mm

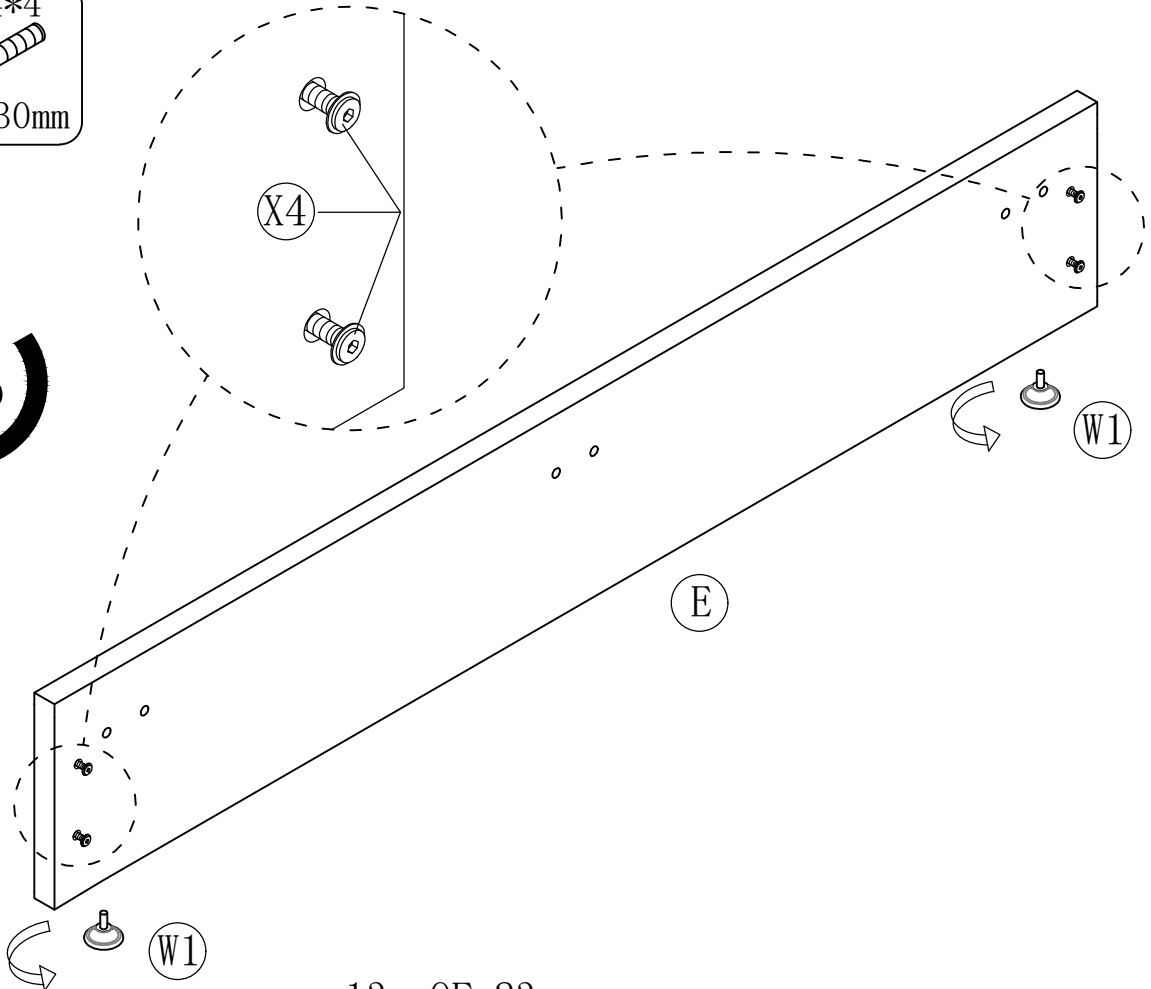

15

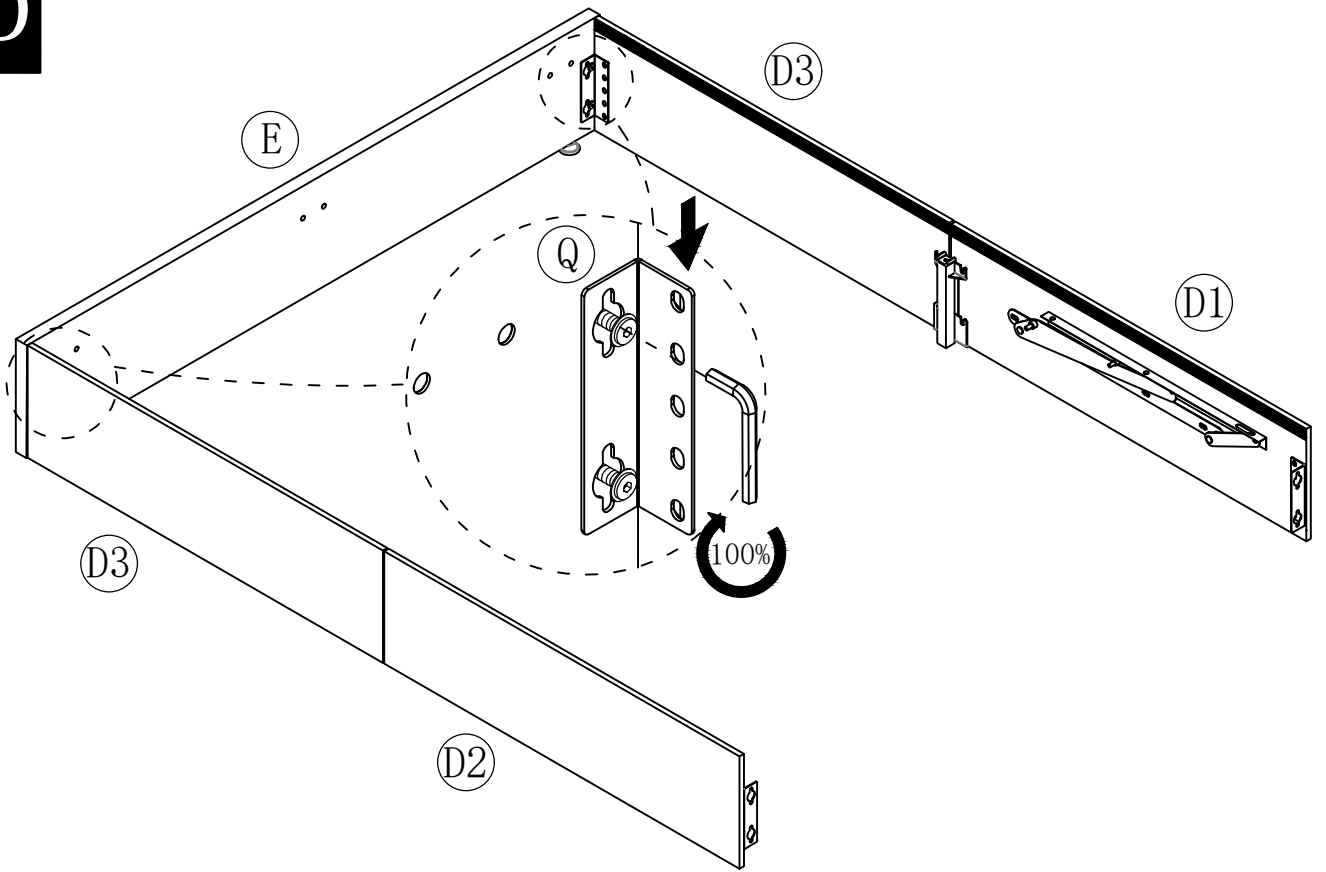

16

- | | |
|-----------------|-----------------|
| X2*6
M8*50mm | X3*2
M8*45mm |
|-----------------|-----------------|

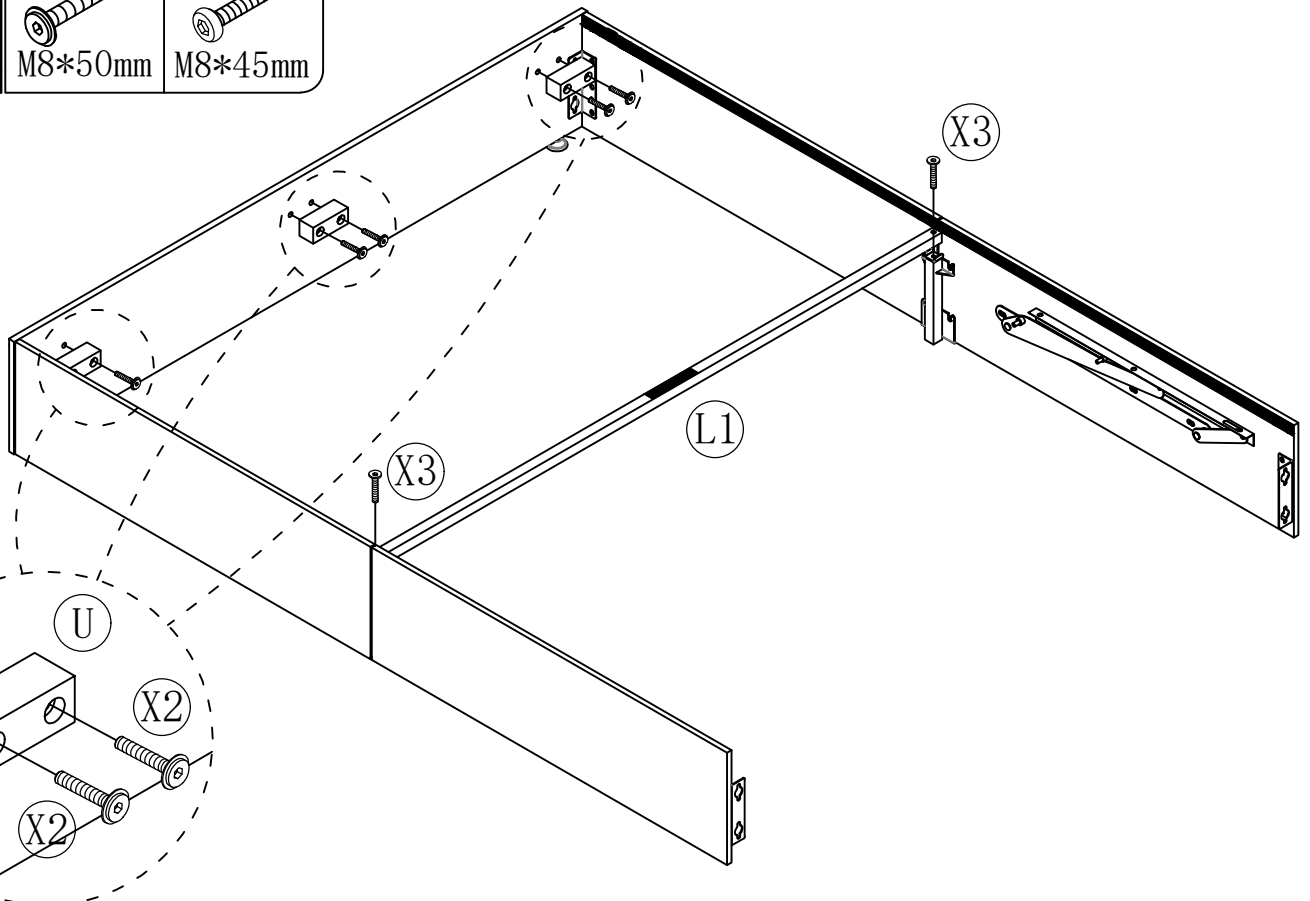

17

X5*4



M8*25mm

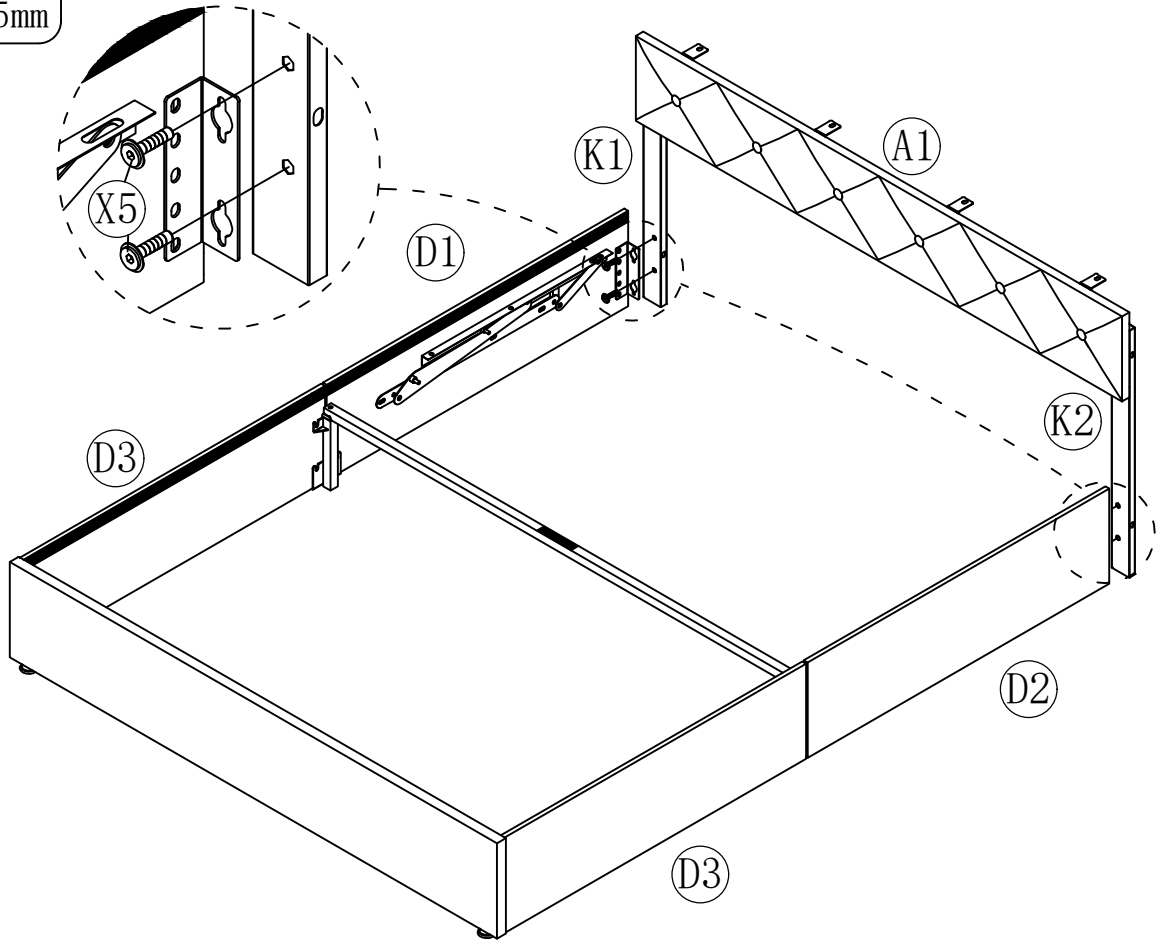

18

X7*6



M8*10mm

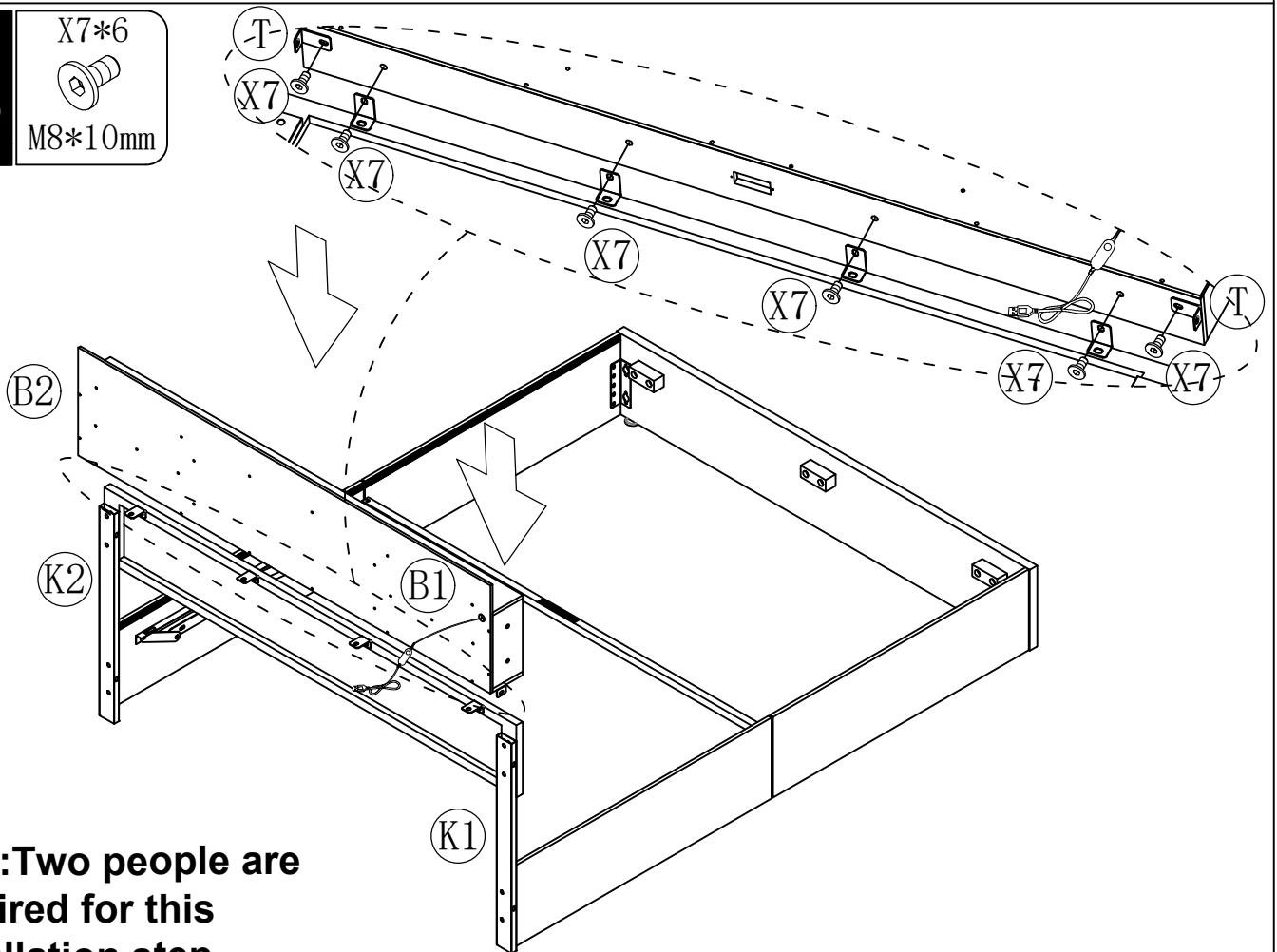

Note: Two people are required for this installation step.

19

X4*4
M8*30mm

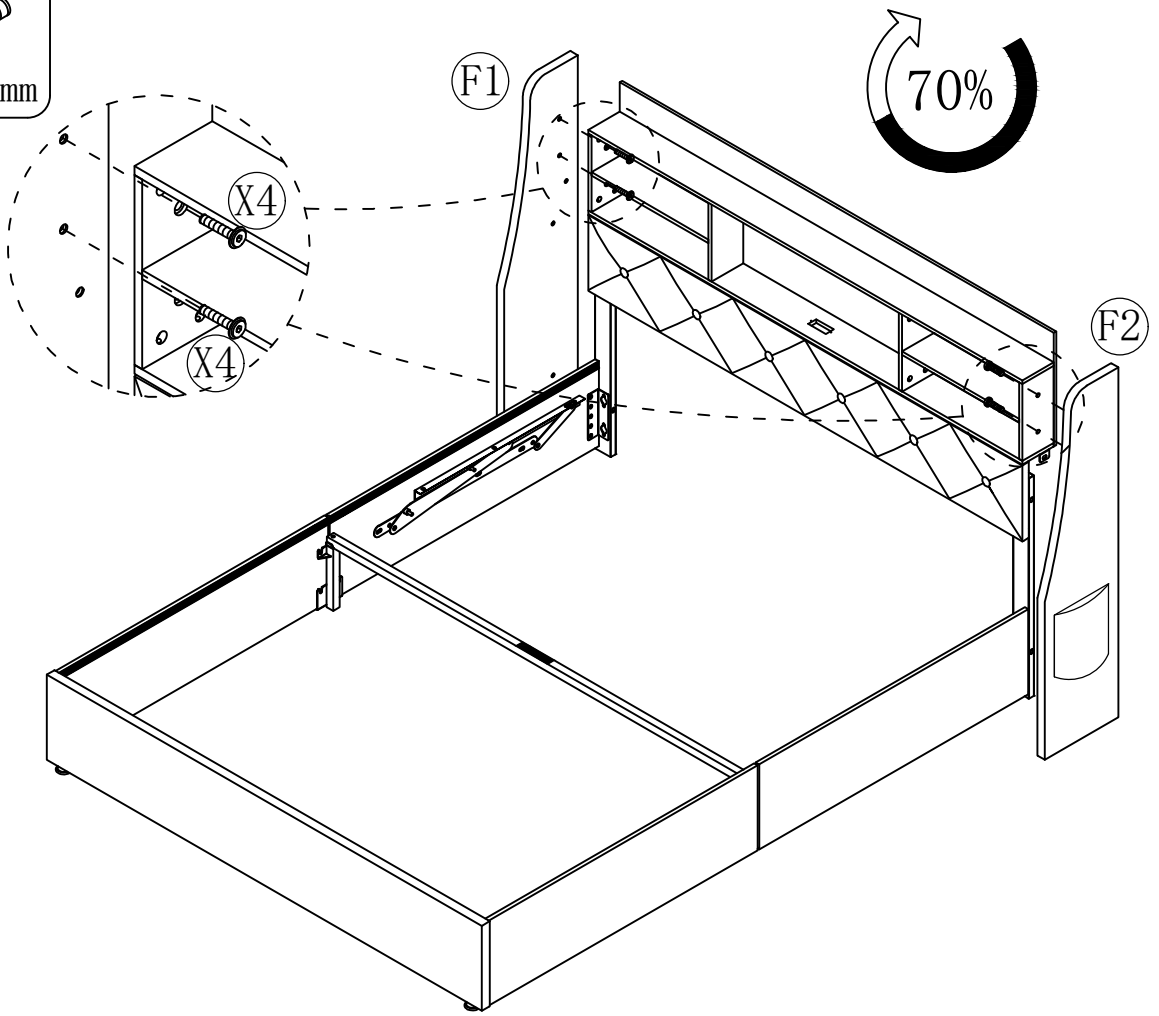

20

X1*4
M8*85mm

X5*2
M8*25mm

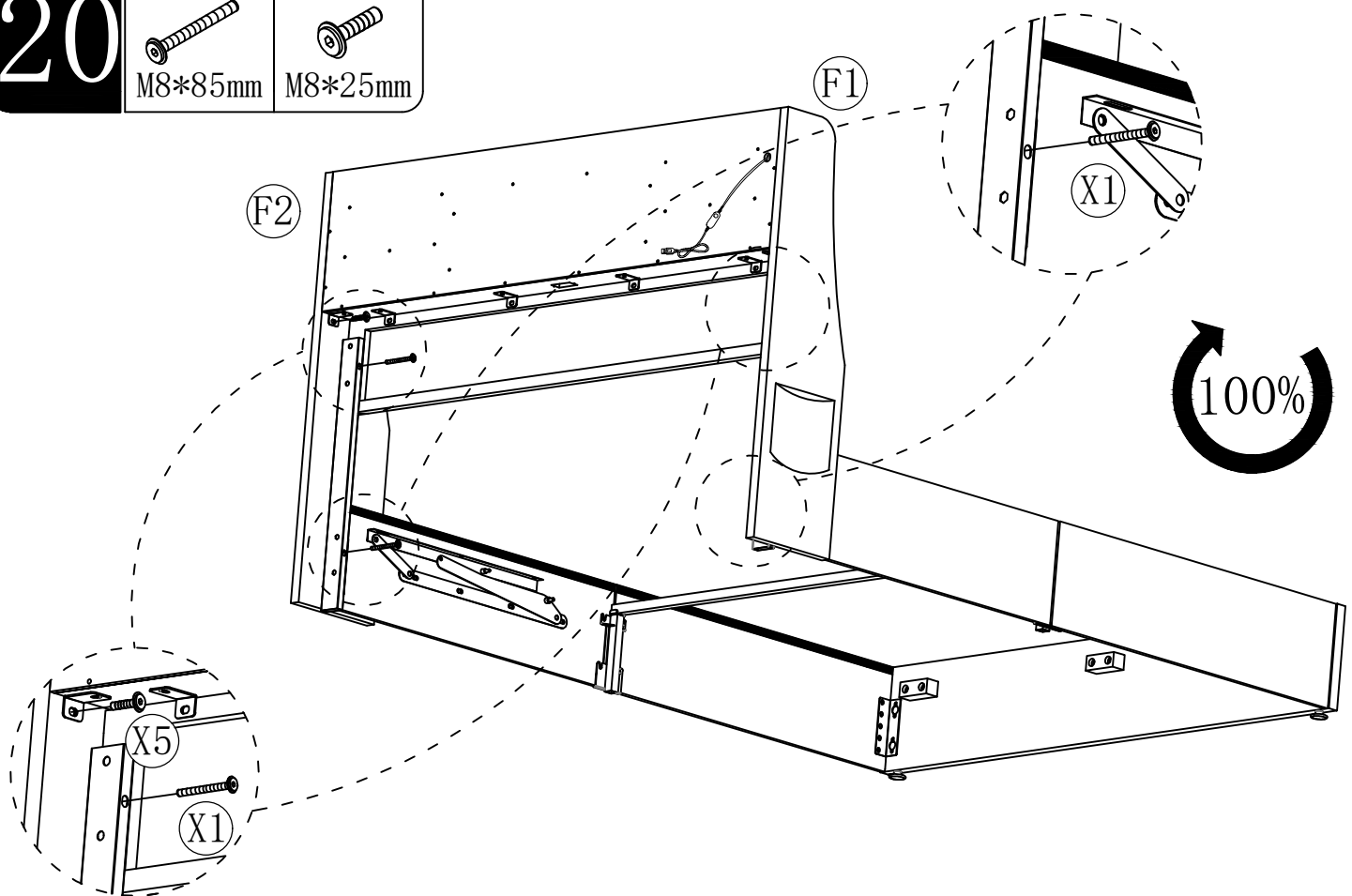

21

X8*2
M3*15mm

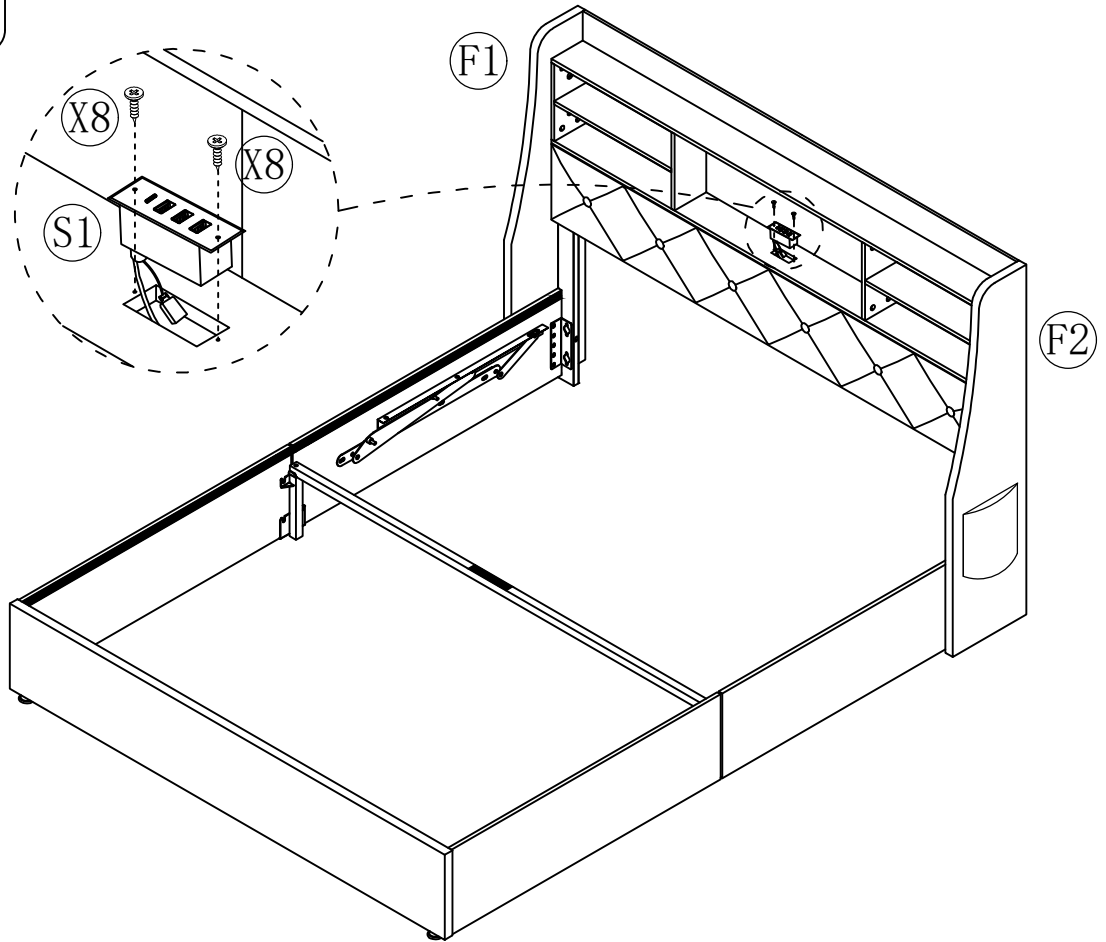

22

X6*2
M8*16mm

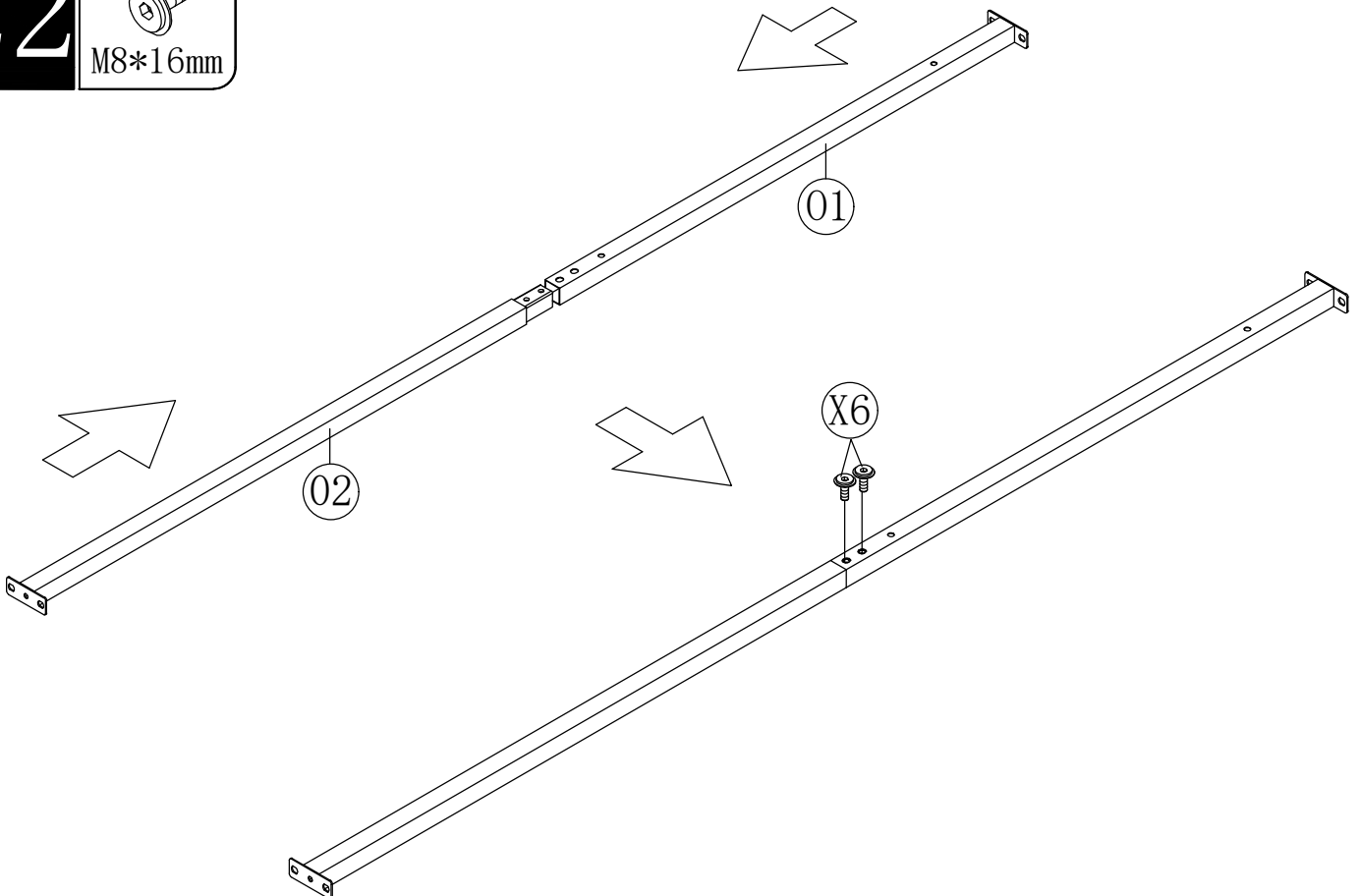

23

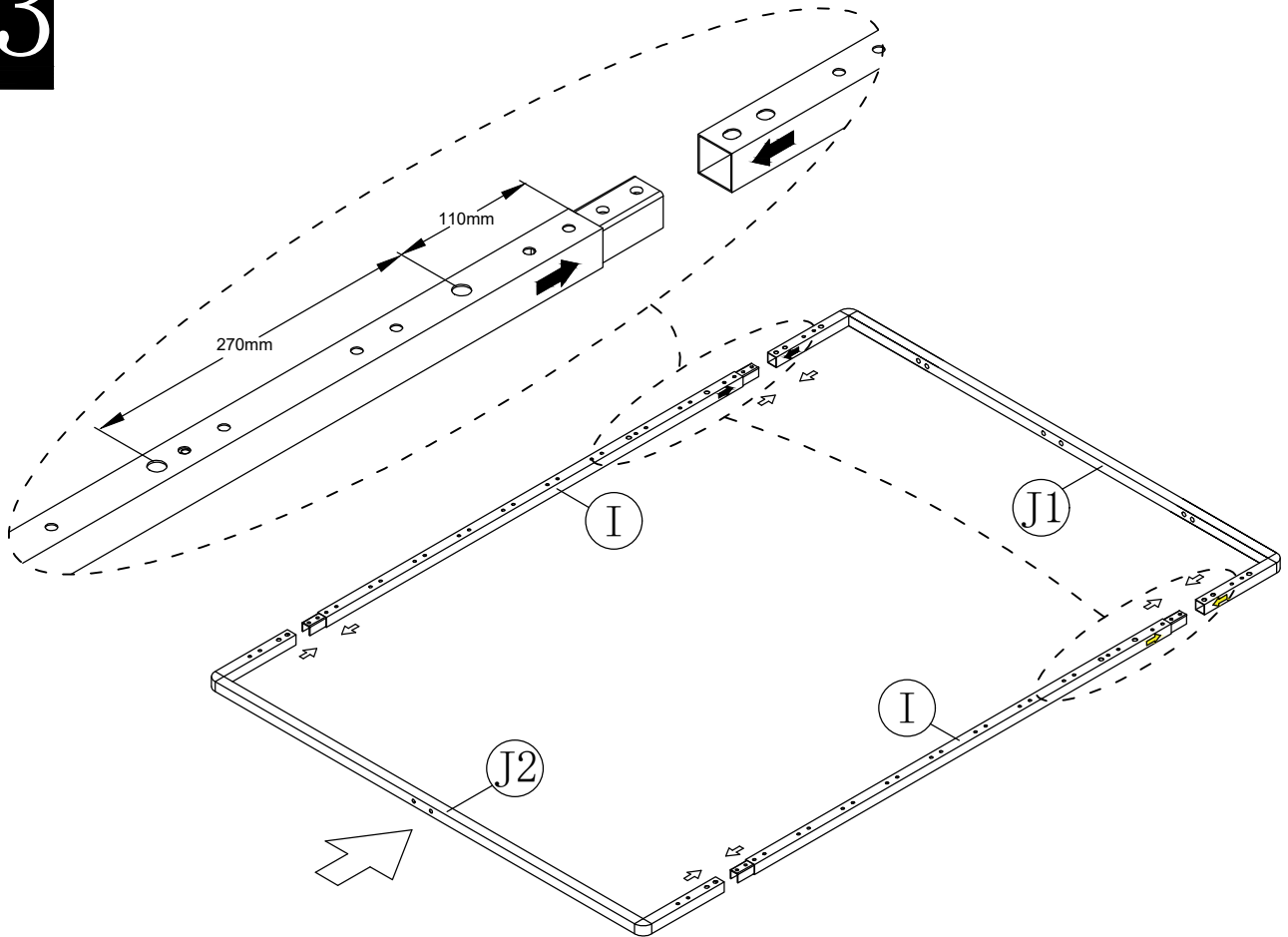

24

X6*8
M8*16mm

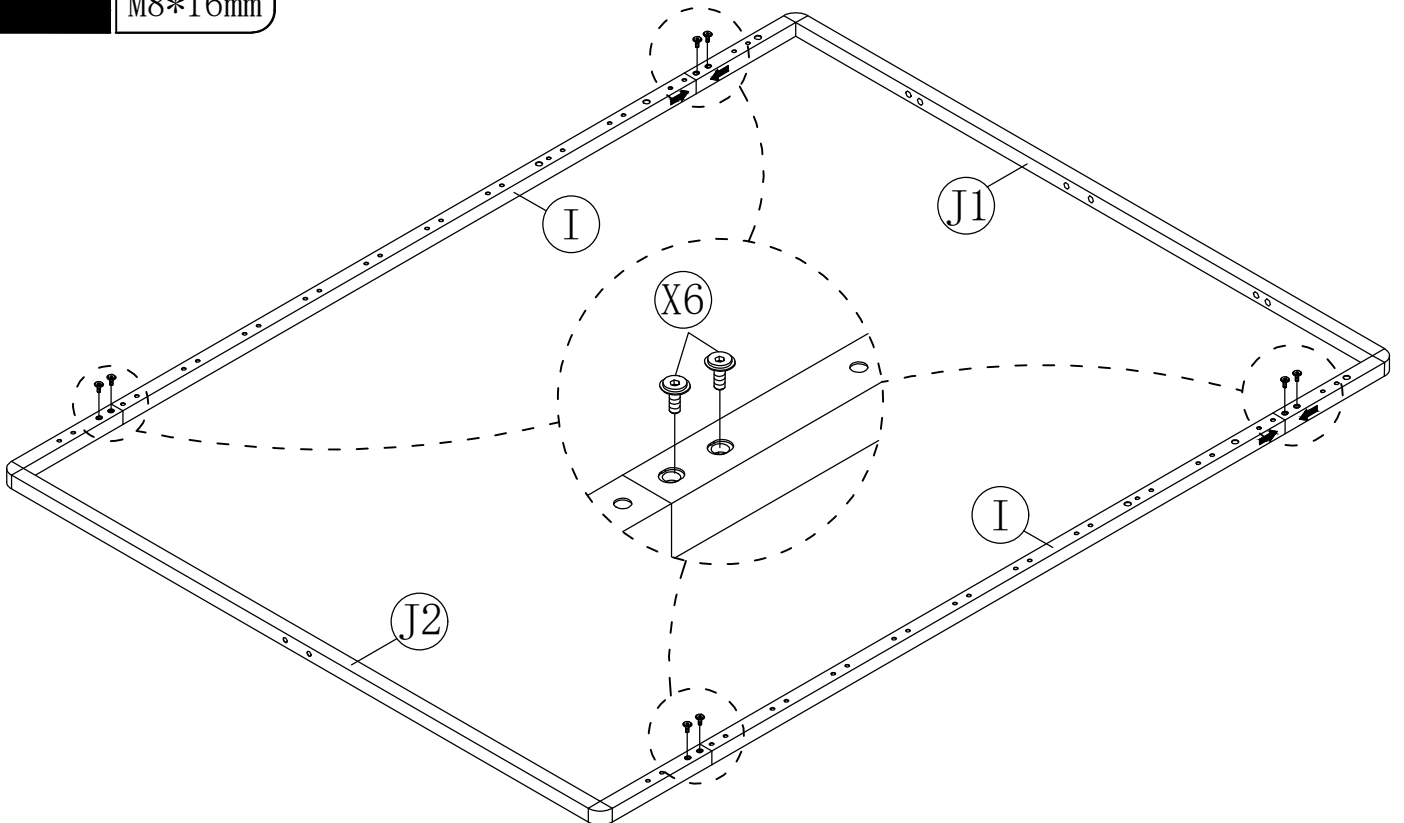

25

X4*8
M8*30mm

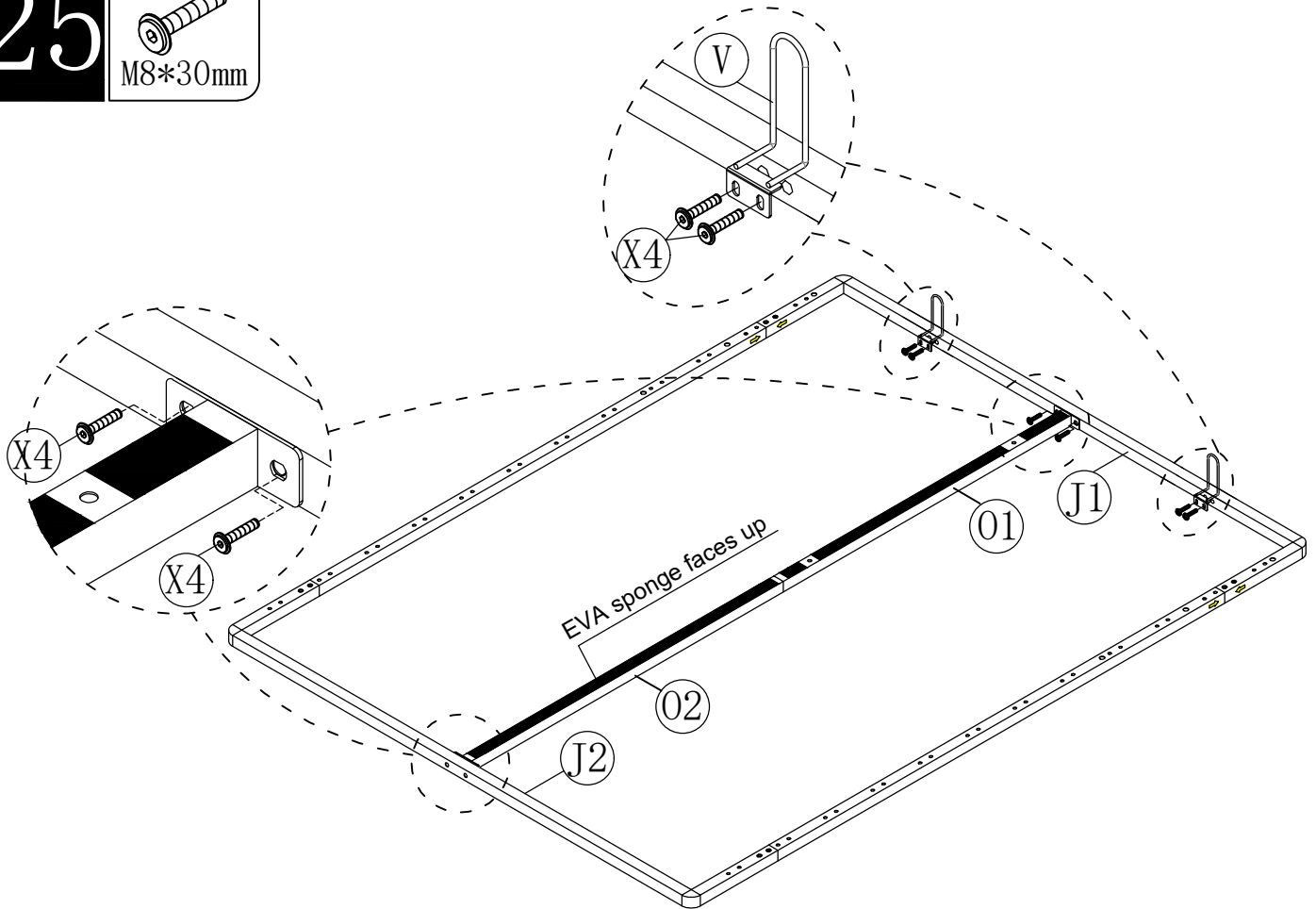

26

X3*6
M8*45mm

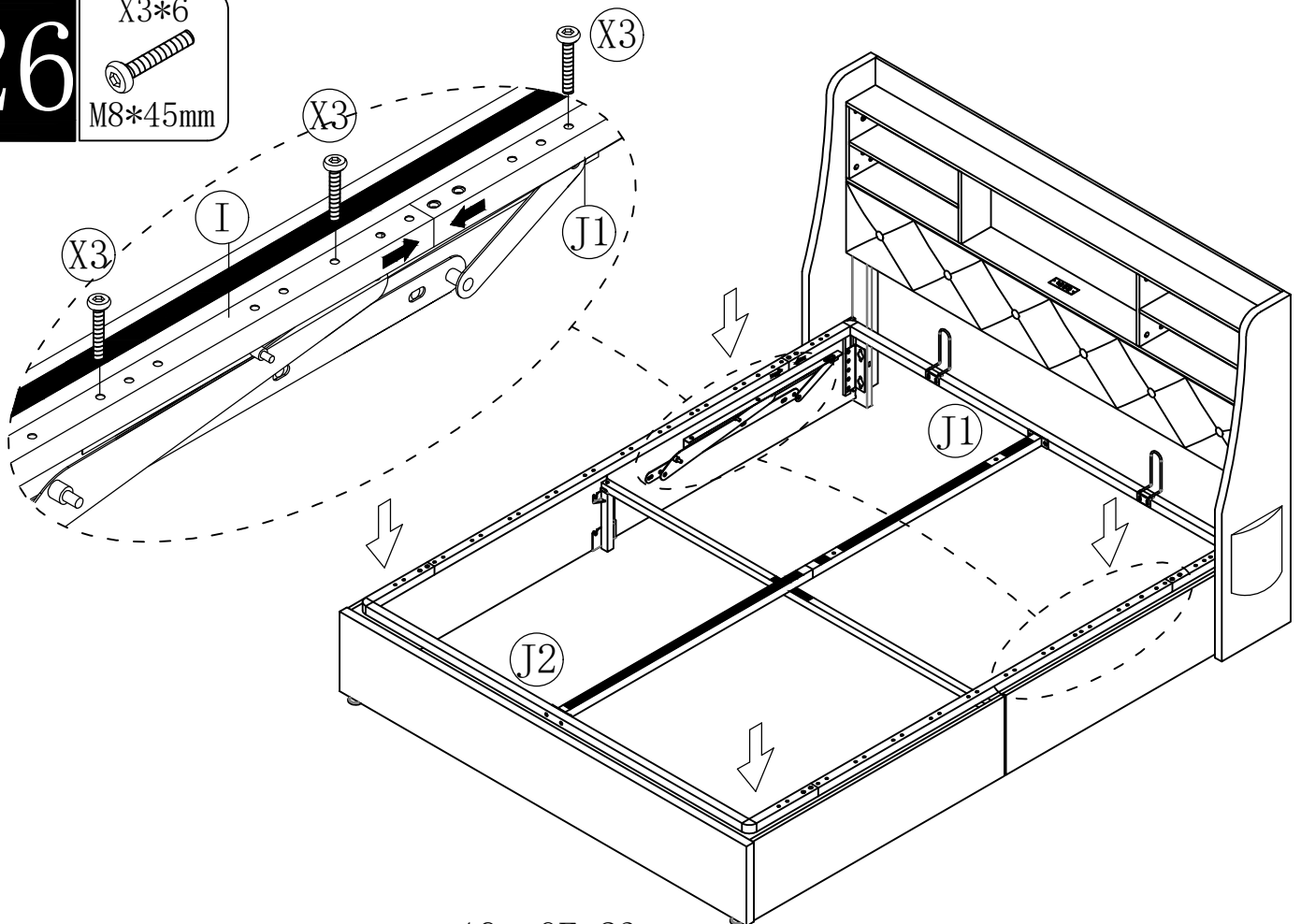

27

Y1*6



M8

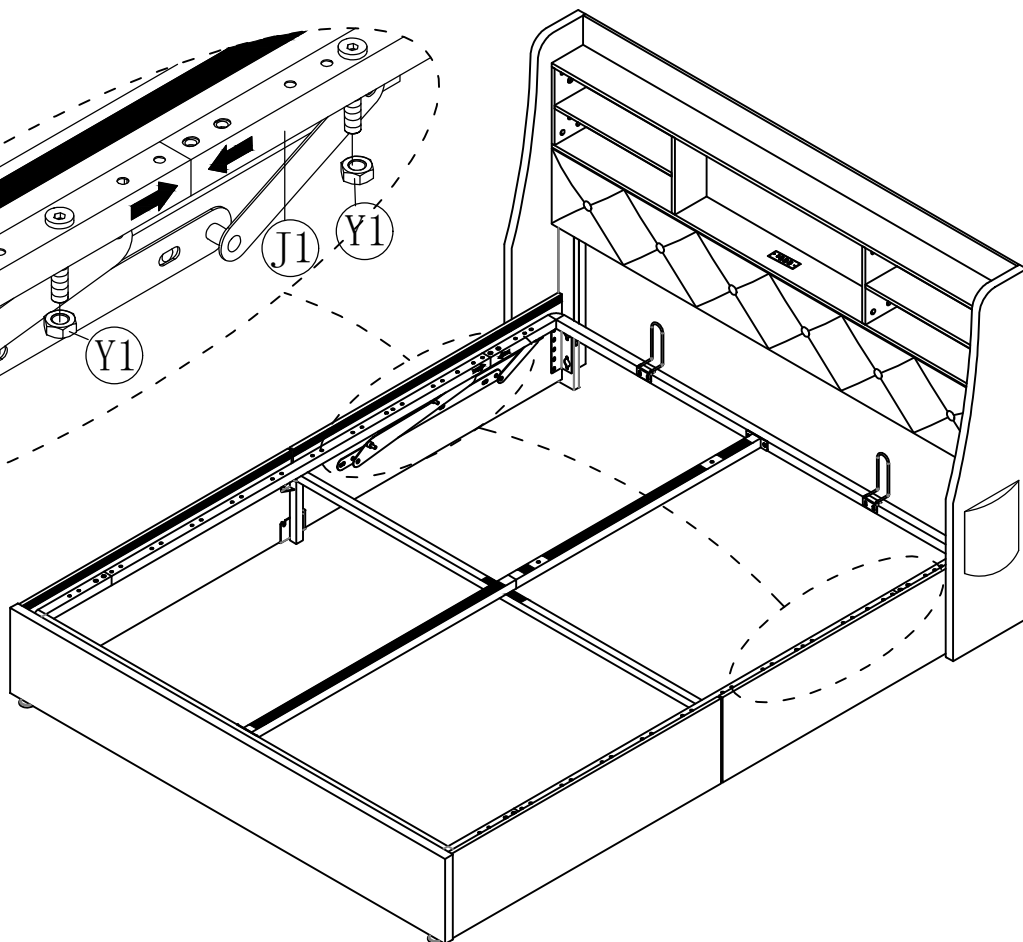
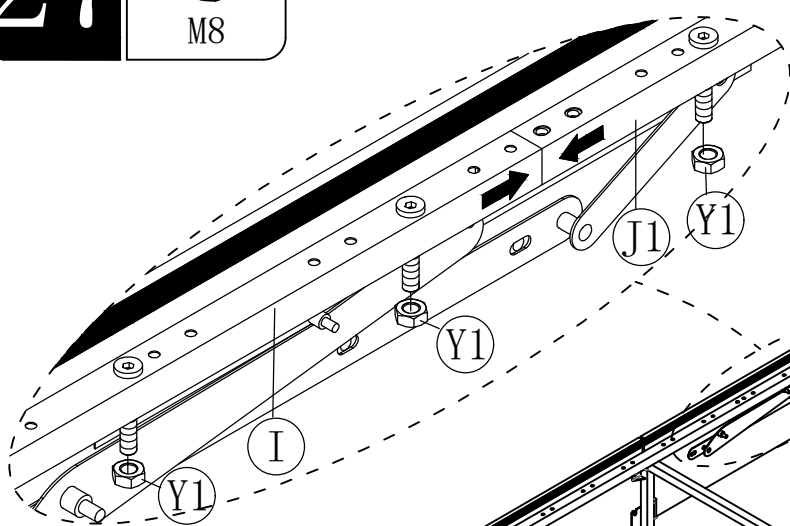

28

Y1*4



M8

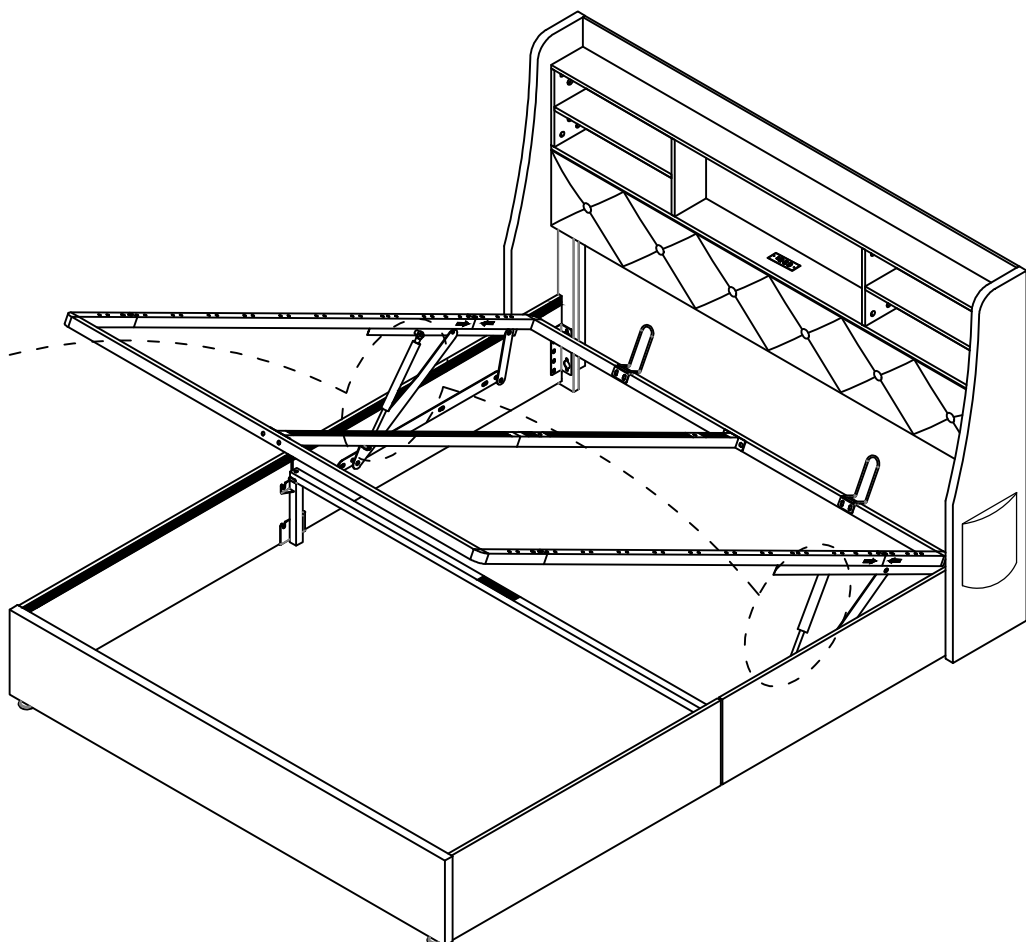
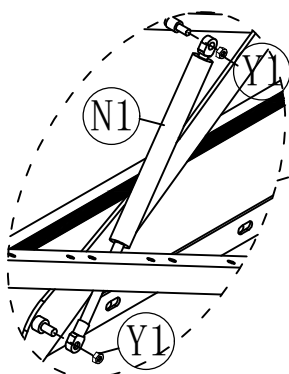

29

X3*2
M8*45mm

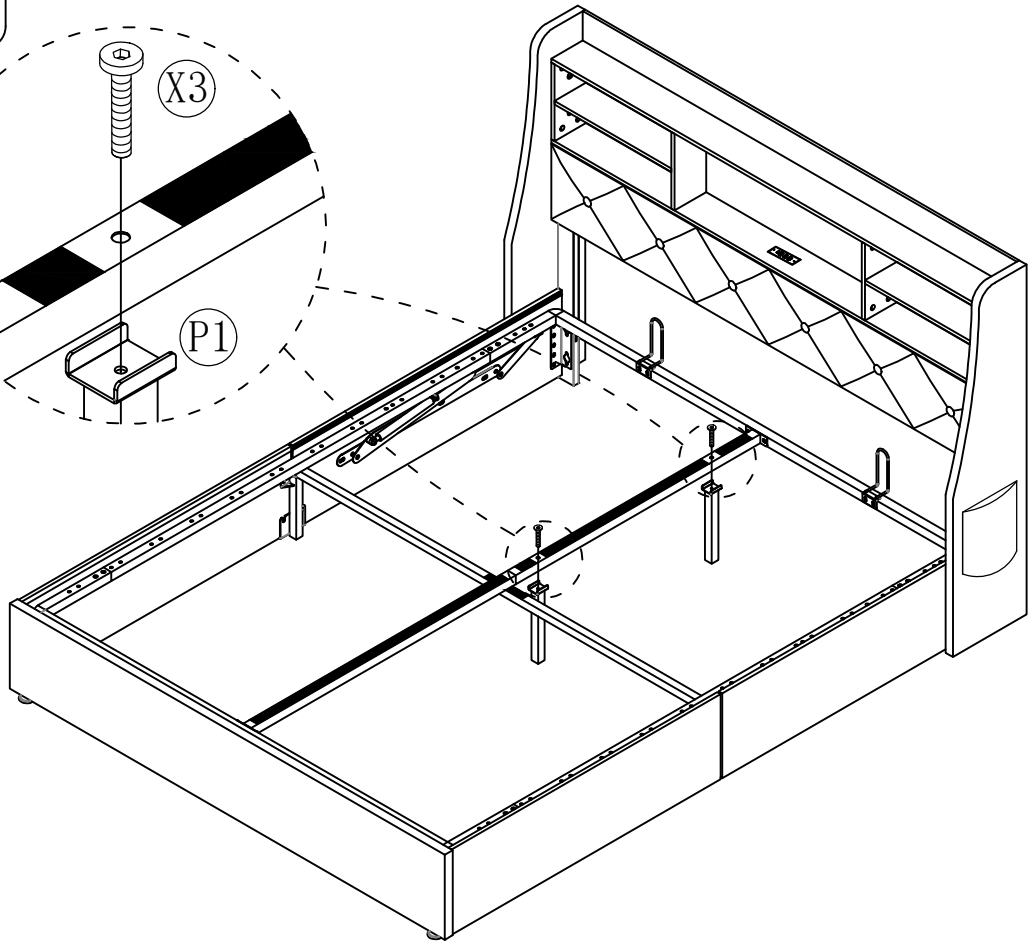
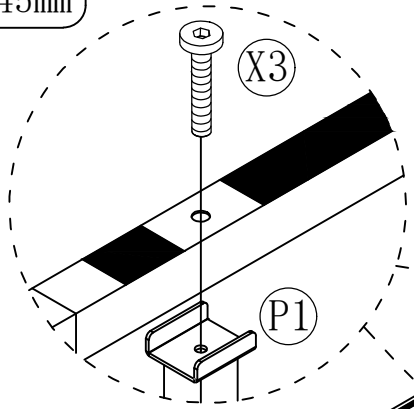

30

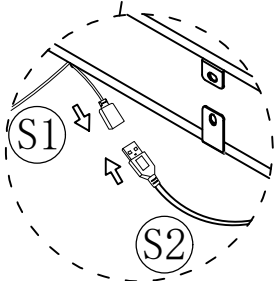
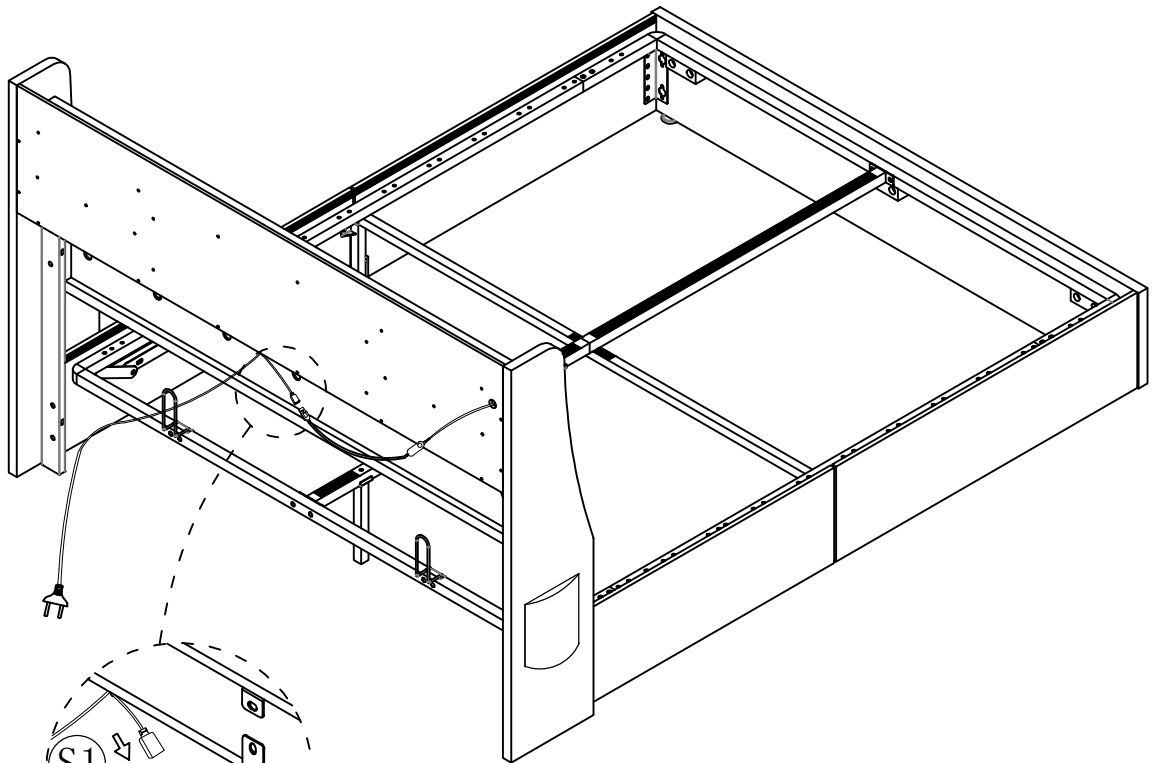

31

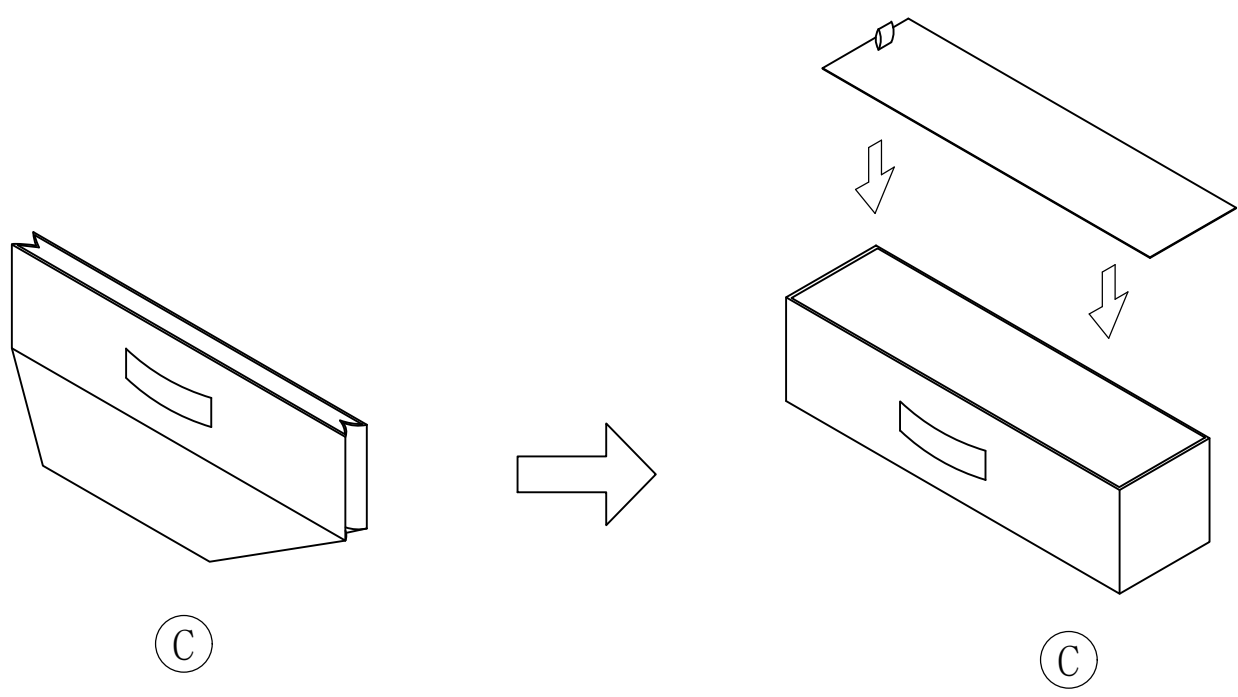

32

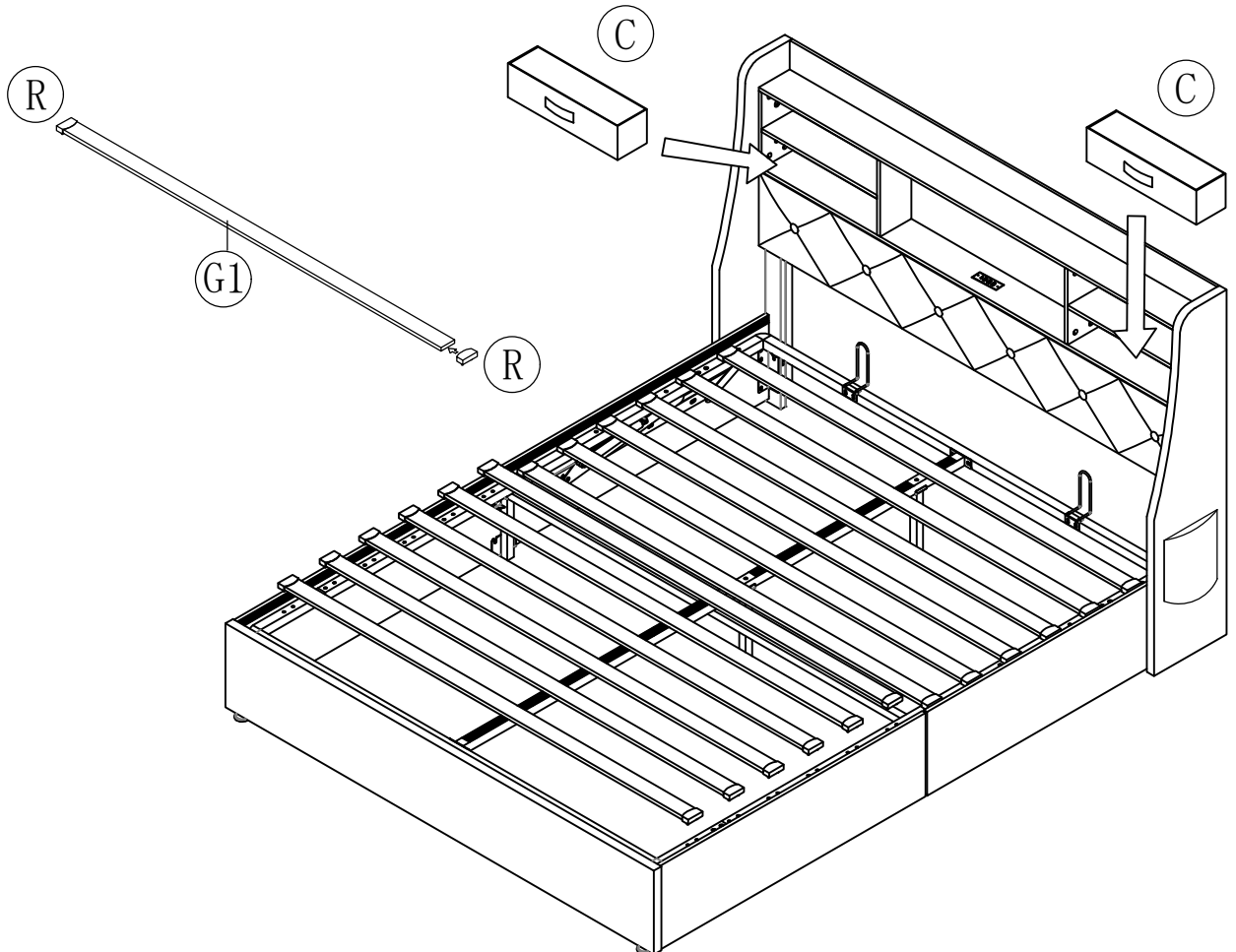

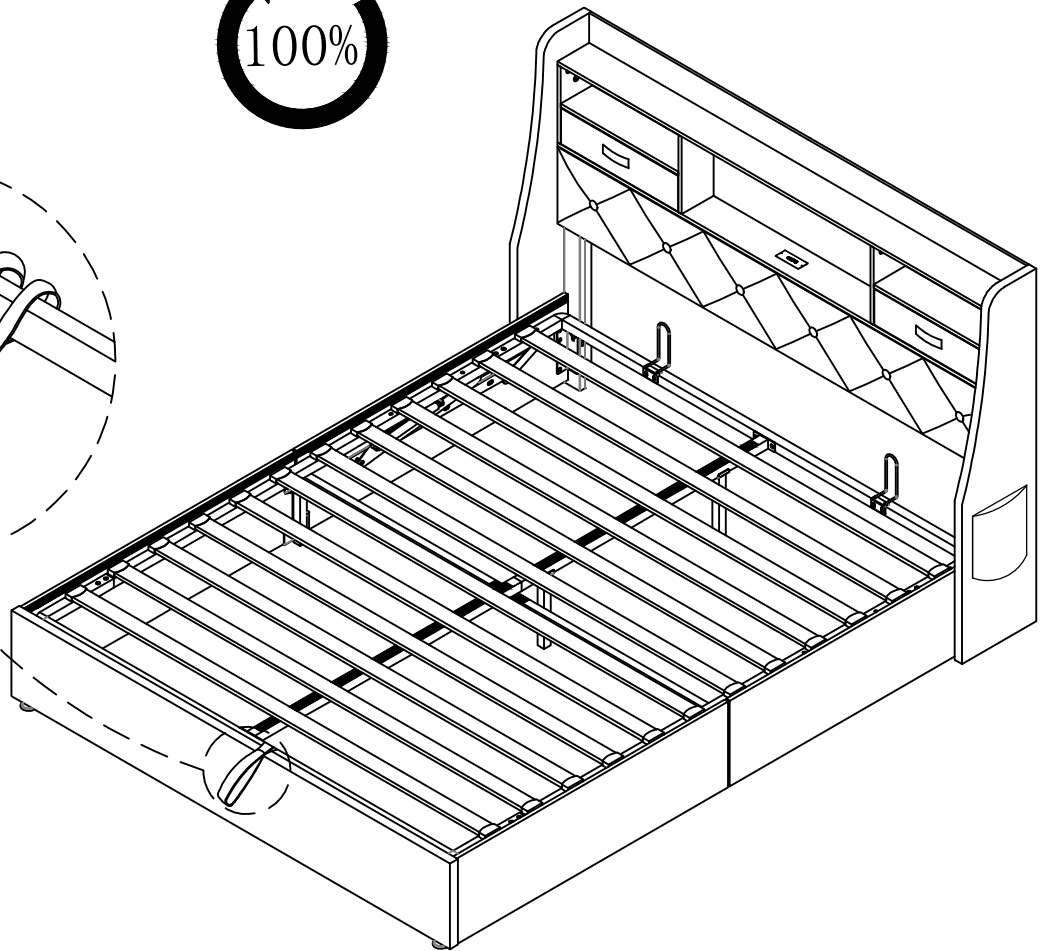
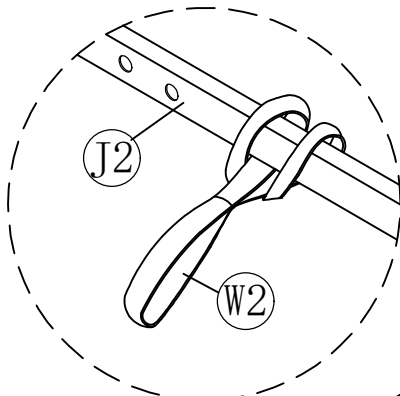

IMPORTANT NOTICE OTTOMAN OPERATING INSTRUCTIONS

Once your bed frame is completely assembled, the slat unit will not operate correctly unless a mattress is placed on the slat frame. Position the mattress on the slat frame whilst it is in the closed position.

PLEASE NOTE - It takes a lot of force to make the initial movement of the ottoman. This is a design feature of the product so that it does not fall shut - the nearer to being closed the ottoman is, the easier it is to move. When the ottoman is almost shut, it will close completely under its own weight.

When lowering the slat unit for the first time, take care to make sure it does not rub unevenly on the inside face of the side rails. If it does, the bed has been assembled slightly out of square. This can be rectified by moving the foot end of the bed slightly to the left or right whilst leaving the head end stationary.

PISTONS

The pistons used in the construction of this product are extremely strong and cannot be operated by hand when taken off the ottoman. All pistons are tested for correct pressure and operation before being attached to the slat unit.

Initially it might appear that the pistons are very stiff when opening and closing the ottoman.

THIS IS PERFECTLY NORMAL

When fully assembled and the mattress is in position, please raise and lower the ottoman 4/5 times to ensure the gas piston are fully lubricated.

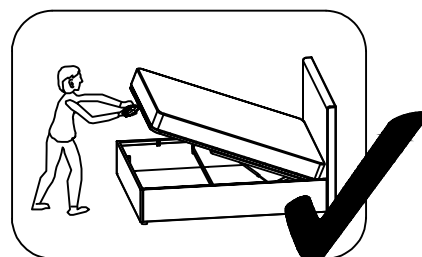
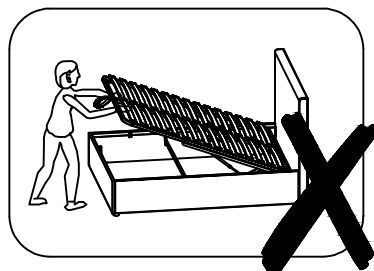

EN:Battery Safety Instructions

1. Do not dispose of used button batteries or remote controls in household trash. To protect the environment and prevent hazardous leakage, please follow these guidelines:
2. Remove button batteries after use and take them to a local battery recycling point or hazardous waste collection site.
3. Do not burn or dismantle the batteries to avoid explosion or toxic release.
4. If the remote control is no longer in use, please deliver it to a certified electronics recycling facility to promote resource reuse.
5. Keep out of reach of children to prevent accidental ingestion or injury.
6. This product does not include batteries; please purchase them separately. The compatible button cell model for the remote control is CR2025,3V
7. If the light strip is not working, please try replacing the battery first. If the issue persists, contact the seller for assistance.
8. **Keep the remote control away from children — keep it away from children!** If the battery is accidentally swallowed, seek medical attention immediately.

DE:Batteriesicherheitshinweise

1. Entsorgen Sie gebrauchte Knopfzellen oder Fernbedienungen nicht im Hausmüll. Um die Umwelt zu schützen und gefährliche Leckagen zu vermeiden, beachten Sie bitte die folgenden Hinweise:
2. Entfernen Sie die Knopfzelle nach dem Gebrauch und bringen Sie sie zu einer örtlichen Batteriesammelstelle oder einem Sondermüllentsorgungszentrum.
3. Batterien nicht verbrennen oder zerlegen, um Explosionen oder die Freisetzung giftiger Stoffe zu vermeiden.
4. Wenn die Fernbedienung nicht mehr verwendet wird, bringen Sie sie zu einer zertifizierten Elektronik-Recyclingstelle, um eine Wiederverwertung zu ermöglichen.
5. Außerhalb der Reichweite von Kindern aufbewahren, um versehentliches Verschlucken oder Verletzungen zu verhindern.
6. Dieses Produkt enthält keine Batterien. Bitte kaufen Sie diese separat. Das kompatible Knopfzellenmodell für die Fernbedienung ist CR2025,3V
7. Wenn der Lichtstreifen nicht funktioniert, versuchen Sie zunächst, die Batterie zu wechseln. Besteht das Problem weiterhin, kontaktieren Sie bitte den Verkäufer.
8. **Halten Sie die Fernbedienung unbedingt von Kindern fern — unbedingt fernhalten!** Wird die Batterie versehentlich verschluckt, suchen Sie sofort medizinische Hilfe auf.

FR:Instructions de sécurité pour les piles

1. Ne jetez pas les piles bouton usagées ou les télécommandes à la poubelle ménagère. Pour protéger l' environnement et éviter tout risque de fuite dangereuse, veuillez suivre les consignes suivantes :
 2. Retirez les piles bouton après usage et déposez-les dans un point de collecte local ou un centre de déchets dangereux.
 3. Ne brûlez pas et ne démontez pas les piles, cela pourrait entraîner une explosion ou libérer des substances toxiques.
 4. Si la télécommande n'est plus utilisée, déposez-la dans un centre de recyclage agréé pour appareils électroniques, afin de favoriser la réutilisation des ressources.
 5. Gardez hors de portée des enfants pour éviter tout risque d'ingestion accidentelle ou de blessure.
- 6.Ce produit ne contient pas de pile. Veuillez l'acheter séparément. Le modèle de pile bouton compatible pour la télécommande est CR2025,3V
- 7.Si le ruban LED ne fonctionne pas, essayez d'abord de remplacer la pile. Si le problème persiste, contactez le vendeur.
- 8.Tenez la télécommande éloignée des enfants — éloignez-la vraiment !** En cas d'ingestion accidentelle de la pile, consultez immédiatement un médecin.



①



②



③



④



⑤



⑥



⑦



⑧





CERTIFICATE OF CONFORMITY

Electromagnetic Compatibility (EMC) Directive 2014/30/EU

This Certificate of Conformity is hereby issued to the product designated below:

Certificate No. : 25EP06144E01
Report No. : EP2506144E01
Date Issue. : 2025-07-07
Applicant's name : Zhangzhou Jinhe Electronic Technology Co., Ltd
Address : 2nd Floor, Building 2, No.15 Jinxia Road, Wenpu Industrial Park,
JiaomeiTown, Zhangzhou City, Fujian Province, China
Manufacturer's name : Zhangzhou Jinhe Electronic Technology Co., Ltd
Address : 2nd Floor, Building 2, No.15 Jinxia Road, Wenpu Industrial Park,
JiaomeiTown, Zhangzhou City, Fujian Province, China
Product Description : Power Supply
Model(s)/Type References : JH-14EN, JH-14Y
Parameters : See appendix for details
Standard(s) : EN 55032:2015+A11:2020+A1:2020
EN 55035:2017+A11:2020
EN IEC 61000-3-2:2019+A1:2021+A2:2024
EN 61000-3-3:2013+A1:2019+A2:2021

On the basis of the referenced test report(s), sample(s) tested of the above product have been found to comply with the standards harmonized with the directives listed on this verification at the time the tests were carried out. Other standards and Directives may be relevant to the product. This verification is part of the full test report(s) and should be read in conjunction with it(them).

Once compliance with all product relevant CE mark directives are verified, including any relevant e.g. risk assessment and production control, the manufacturer may indicate compliance by signing a Declaration of Conformity themselves and applying the mark to products identical to the tested sample(s).

Approved By

.....
Eric Liu

Director of engineering department

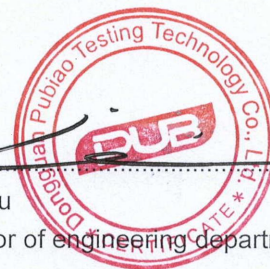



CERTIFICATE OF CONFORMITY

Electromagnetic Compatibility (EMC) Directive 2014/30/EU

Appendix of Certificate No.: 25EP06144E01

Ratings:

Input: 100-240V~, 50/60Hz, 1.5A Max,

Output: USB-C: 5.0V \Rightarrow 3.0A 9.0V \Rightarrow 2.22A 12V \Rightarrow 1.67A

PPS: 3.3-5.9V \Rightarrow 3.0A 3.3-11V \Rightarrow 1.8A

USB-A1: 5.0V \Rightarrow 3.0A 9.0V \Rightarrow 2.0A 12V \Rightarrow 1.5A

USB-A2: 5.0V \Rightarrow 2.0A

USB-A3: 5.0V \Rightarrow 2.0A

USB-A4: 12.0V \Rightarrow 1.5A

USB-C+A2: 20W+5.0V \Rightarrow 0.4A

USB-C+A3: 20W+5.0V \Rightarrow 0.4A

USB-C+A4: 20W+12.0V \Rightarrow 0.2A

USB-A1+A2: 18W+5.0V \Rightarrow 0.4A

USB-A1+A3: 18W+5.0V \Rightarrow 0.4A

USB-A1+A4: 18W+12.0V \Rightarrow 0.2A

USB-A2+A3: 5.0V \Rightarrow 1.0A+5.0V \Rightarrow 1.0A

USB-A2+A4: 5.0V \Rightarrow 2.0A+12V \Rightarrow 1.0A

USB-A3+A4: 5.0V \Rightarrow 2.0A+12V \Rightarrow 1.0A

(USB-C+A1)+(USB-A2+A3)+USB-A4: 5.0V \Rightarrow 2.0A+5V \Rightarrow 1.0A +12V \Rightarrow 0.2A



Dongguan Pubiao Testing Technology Co., Ltd

Room 101, Building 1, No.30, Minghua Road, Shijie, Shijie Town, Dongguan, Guangdong, China.

Tel: +86 769 81813516 E-mail: service@pubiaotest.com Web: www.pubiaotest.com

Shenzhen ZKT Technology Co., Ltd.
1/F, No. 101, Building B, No. 6, Tangwei Community Industrial Avenue,
Fuhai Street, Bao'an District, Shenzhen, China



Certificate of Compliance

Certificate Number: ZKT-2403202772C

Certificate's Holder : Shenzhen Pinchengxin Technology Co., Ltd
3rd Floor, 8th Building Yuanling Industrial Zone, No. 39
Yuanlingcun Road, Shiyan Street, Bao'an District,
Shenzhen

Manufacturer : Shenzhen Pinchengxin Technology Co., Ltd
3rd Floor, 8th Building Yuanling Industrial Zone, No. 39
Yuanlingcun Road, Shiyan Street, Bao'an District,
Shenzhen

Trade Mark : N/A

Product : 5050 RGB LED Strip Lights with Bluetooth App Controller
and 2.4G Remote

Model(s) : 5050 RGB LED Strip Lights

Test Standard : Art.3.1(a) Safety EN IEC 62368-1:2020+A11:2020

Art.3.1(a) Health EN IEC 62311:2020
EN 50665:2017

Art.3.1(b) EMC ETSI EN 301 489-1 V2.2.3 (2019-11)
ETSI EN 301 489-17 V3.2.4 (2020-09)

Art.3.2 Radio ETSI EN 300 328 V2.2.2 (2019-07)

This Attestation of Compliance is issued on a voluntary basis for electrical equipment below the voltage limits of Radio Equipment Directive (RED) 2014/53/EU. The essential requirements are fulfilled accordingly based on the technical specifications applicable at the time of issuance.

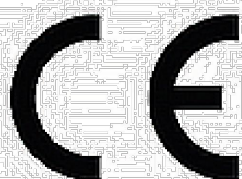

This Certificate of Conformity is based on single evaluation of the submitted sample(s) of the above mentioned product. It does not imply an assessment of the whole product and relevant Directives to be observed.



FR

**Cet appareil,
ses cordons,
et batterie
se recyclent**

**À DÉPOSER
EN MAGASIN**



OU

**À DÉPOSER
EN DÉCHÈTERIE**



**Points de collecte sur www.quefairedemesdechets.fr
Privilégiez la réparation ou le don de votre appareil !**