

# Installation sanleitung

# Installation Instruction

# Instruction d'installation

SKU: WF316833AAG / WF316834AAG

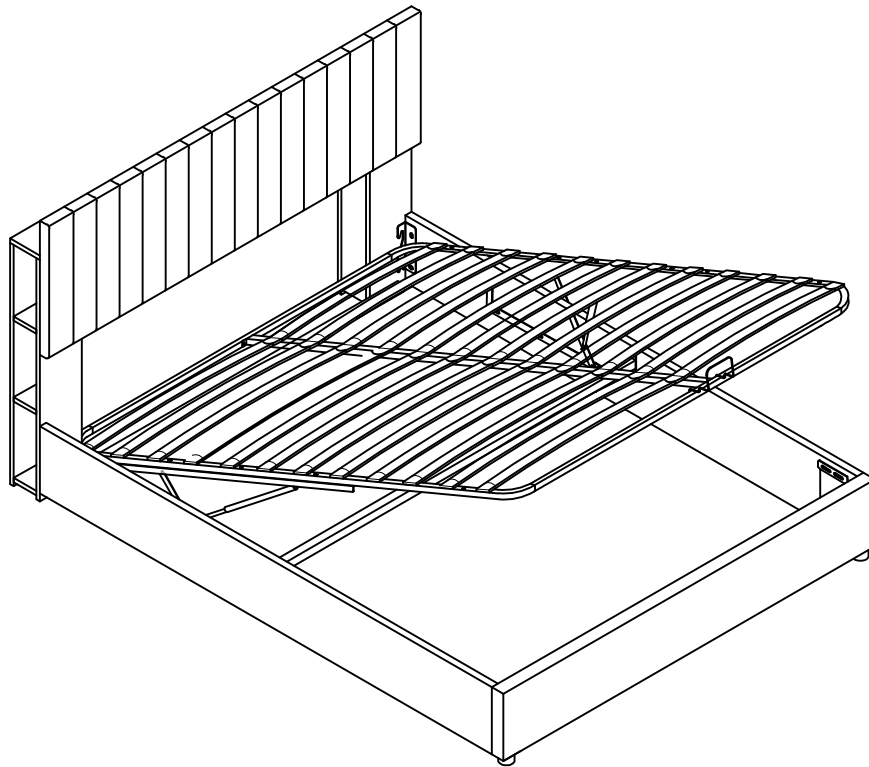

Unser Produkt wird Ihnen in 2 Paketen geliefert. Die Lieferzeiten dieser 2 Pakete können abweichen, bitte haben Sie etwas Geduld und vielen Dank für Ihr Verständnis.

Our product will be delivered to you in 2 packages. The delivery times of these 2 packages may differ, please be patient and thank you for your understanding.

Notre produit vous sera livré en 2 colis. Les délais de livraison de ces 2 colis peuvent différer, soyez patient et merci pour votre compréhension.



## English

### IMPORTANT FOR GAS LIFT BEDS&MAINTAINCE

- Please place the mattress on top of the bed frame.
- Please do not pull on the strap handles.
- Please press heavily to release the compressed gas.
- Periodically check all screw & fixings to ensure they are secure.
- When moving your product, carefully lift into place.
- Wipe clean with a slightly damp cloth- please do not use abrasive chemicals or bleach.
- Do NOT allow children to operate the lift mechanism.
- Do NOT allow children near the lift base when operating the mechanism.
- Do NOT stand inside the bed or the internal storage base.
- Do NOT overload the internal storage base.
- DO NOT jump on the product or any of its parts.

## Deutsch

### WICHTIG FÜR GASLIFT-BETTEN&WARTUNG

- Bitte legen Sie die Matratze oben auf den Bettrahmen.
- Bitte ziehen Sie nicht an den Gurtgriffen.
- Bitte drücken Sie kräftig, um das komprimierte Gas freizusetzen.
- Überprüfen Sie regelmäßig alle Schrauben und Befestigungen, um sicherzustellen, dass sie sicher sind.
- Wenn Sie Ihr Produkt bewegen, heben Sie es vorsichtig an seinen Platz.
- Mit einem leicht feuchten Tuch abwischen - bitte keine scheuernden Chemikalien oder Bleichmittel verwenden.
- Erlauben Sie Kindern NICHT, den Hebemechanismus zu bedienen.
- Lassen Sie Kinder NICHT in die Nähe des Liftsockels, wenn Sie den Mechanismus bedienen.
- Stellen Sie sich NICHT in das Bett oder in die Innenablage.
- Überlasten Sie den internen Liftsockel NICHT.
- Springen Sie NICHT auf das Produkt oder eines seiner Teile.

## Français

### IMPORTANT POUR LES LITS À RELEVAGE DE GAZ&MAINTENANCE

- Veuillez placer le matelas sur le dessus du cadre de lit.
- Ne tirez pas sur les poignées de la sangle.
- Appuyez fortement pour libérer le gaz comprimé.
- Vérifiez régulièrement que toutes les vis et fixations sont bien en place.
- Lorsque vous déplacez votre produit, soulevez-le avec précaution pour le mettre en place.
- Nettoyez avec un chiffon légèrement humide - n'utilisez pas de produits chimiques abrasifs ou d'eau de Javel.
- Ne laissez pas les enfants utiliser le mécanisme de levage.
- Ne laissez pas les enfants s'approcher de la base de levage lorsqu'ils actionnent le mécanisme.
- Ne vous tenez PAS à l'intérieur du lit ou de la base de stockage interne.
- Ne surchargez pas la base de stockage interne.
- Ne pas sauter sur le produit ou l'une de ses parties.

## Italiano

### IMPORTANTE PER I LETTI CON SOLLEVAMENTO A GAS E LA MANUTENZIONE

- Posizionare il materasso sopra la struttura del letto.
- Non tirare le maniglie della cinghia.
- Premere con forza per rilasciare il gas compresso.
- Controllare periodicamente tutte le viti e i fissaggi per assicurarsi che siano saldi.
- Quando si sposta il prodotto, sollevarlo con cautela.
- Pulire con un panno leggermente umido, senza usare prodotti chimici abrasivi o candeggina.
- NON permettere ai bambini di azionare il meccanismo di sollevamento.
- NON permettere ai bambini di avvicinarsi alla base di sollevamento quando si aziona il meccanismo.
- NON sostare all'interno del letto o della base di contenimento interna.
- NON sovraccaricare la base di contenimento interna.
- NON saltare sul prodotto o sulle sue parti.

## Español

### IMPORTANTE PARA LAS CAMAS ELEVADORAS DE GAS & MANTENIMIENTO



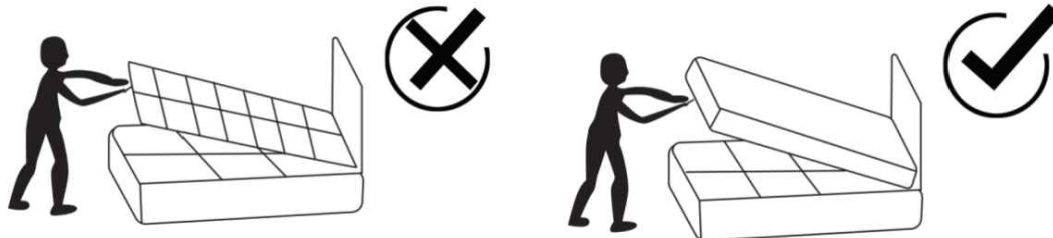



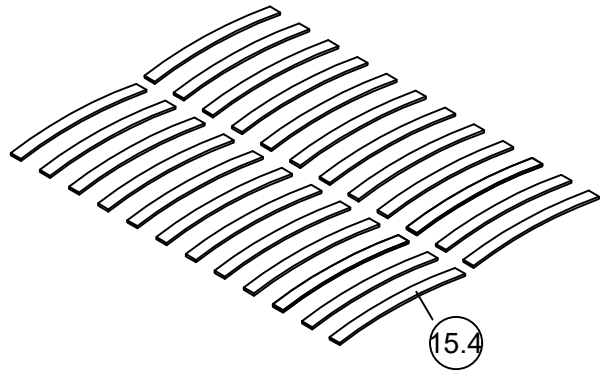
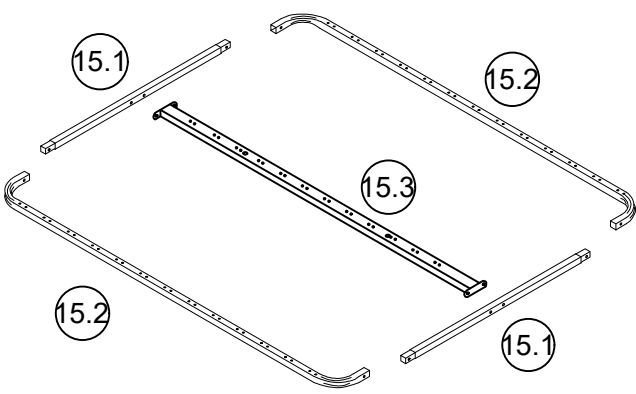
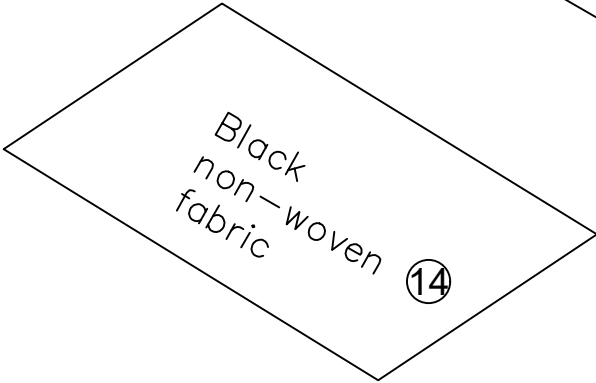
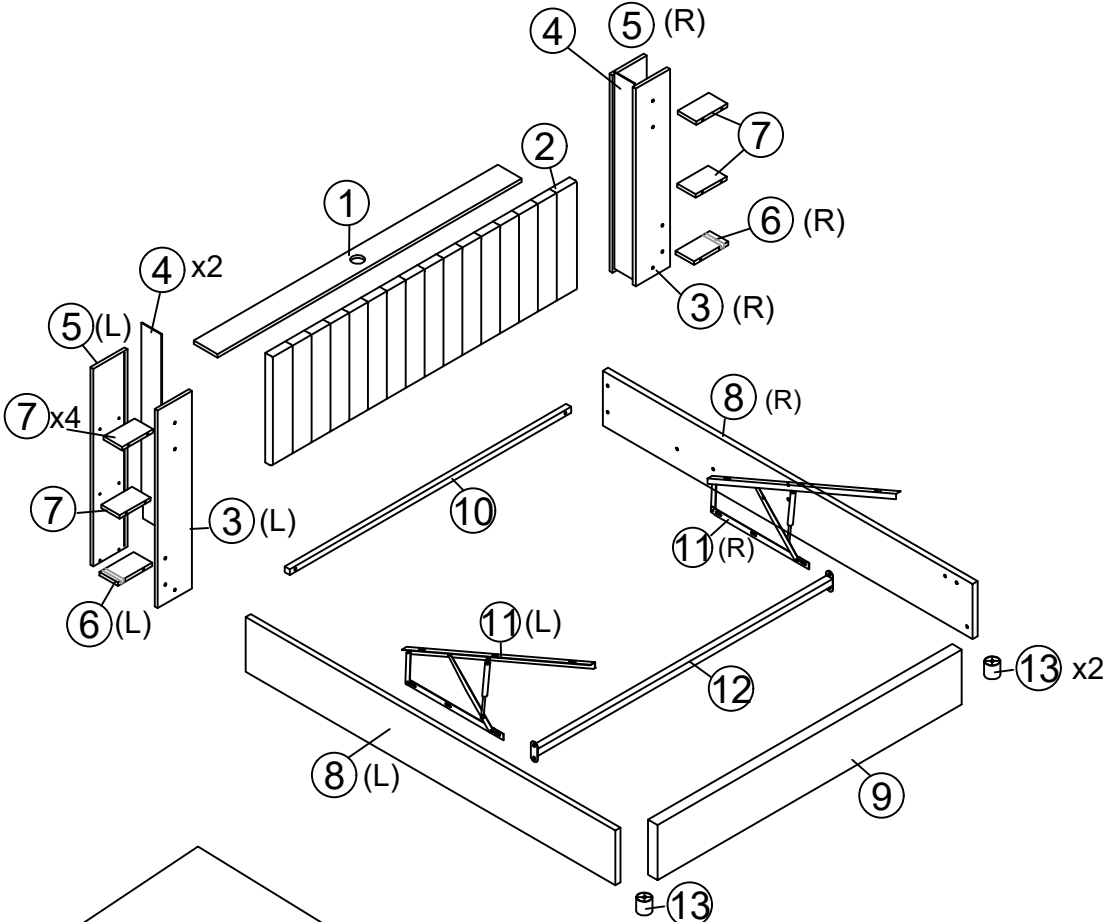

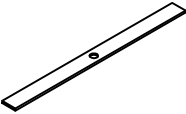
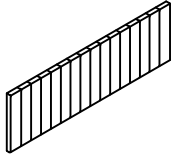

- Coloque el colchón sobre el somier.
- No tire de las asas de la correa.
- Presione con fuerza para liberar el gas comprimido.
- Compruebe periódicamente que todos los tornillos y fijaciones estén bien sujetos.
- Al mover el producto, levántelo con cuidado para colocarlo en su sitio.
- Limpie con un paño ligeramente humedecido; no utilice productos químicos abrasivos ni lejía.
- NO permita que los niños accionen el mecanismo de elevación.
- NO permita que los niños se acerquen a la base elevadora cuando accionen el mecanismo.
- NO se ponga de pie dentro de la cama o de la base de almacenamiento interna.
- NO sobrecargue el somier.
- NO salte sobre el producto ni sobre ninguna de sus piezas.





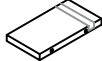



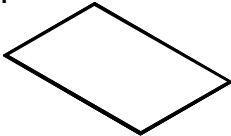

# Stückliste

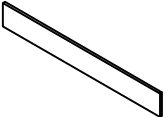
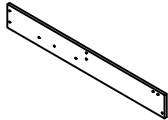
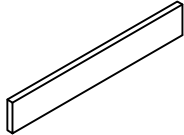



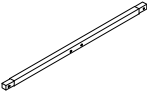

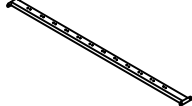







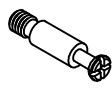

Part List-Stückliste+WF316833AAG

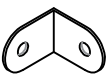
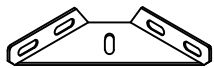
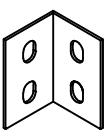
<b>1</b> x1 	<b>2</b> x1 	<b>3L</b> x1 
<b>3R</b> x1 	<b>4</b> x2 	<b>5L</b> x1 
<b>5R</b> x1 	<b>6L</b> x1 	<b>6R</b> x1 
<b>7</b> x4 	<b>11L</b> x1 	<b>11R</b> x1 
<b>14</b> x1 		

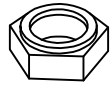
Part List-Stückliste+WF316834AAG

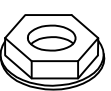
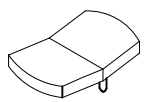
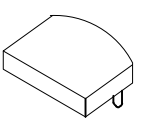
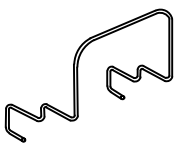
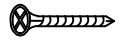
<b>8L</b> x1 	<b>8R</b> x1 	<b>9</b> x1 
<b>10</b> x1 	<b>12</b> x1 	<b>13</b> x2 
<b>15.1</b> x2 	<b>15.2</b> x2 	<b>15.3</b> x1 
<b>15.4</b> x24 		

# Hardware List- Hardware-Liste +WF316834AAG

<p>A x1</p> 	<p>B x4</p>  <p>M8x30mm</p>	<p>C x16</p>  <p>M8x45mm</p>
<p>D x34</p>  <p>M8x16mm</p>	<p>E x2</p> 	<p>F x32</p> 
<p>G x32</p> 	<p>H x4</p> 	<p>I x2</p> 
<p>J x1</p> 	<p>K x2</p>  <p>M4x50mm</p>	<p>L x4</p> 
<p>M x1</p> 	<p>N x14</p> 	<p>O x12</p> 
<p>P x24</p> 	<p>Q x1</p> 	<p>R x3</p>  <p>M3x16mm</p>
<p>S x1</p> 	<p>T x1</p>  <p>T2</p>	<p>U x1</p> 
<p>V x2</p>  <p>M8x12mm</p>		

# Schritt 1

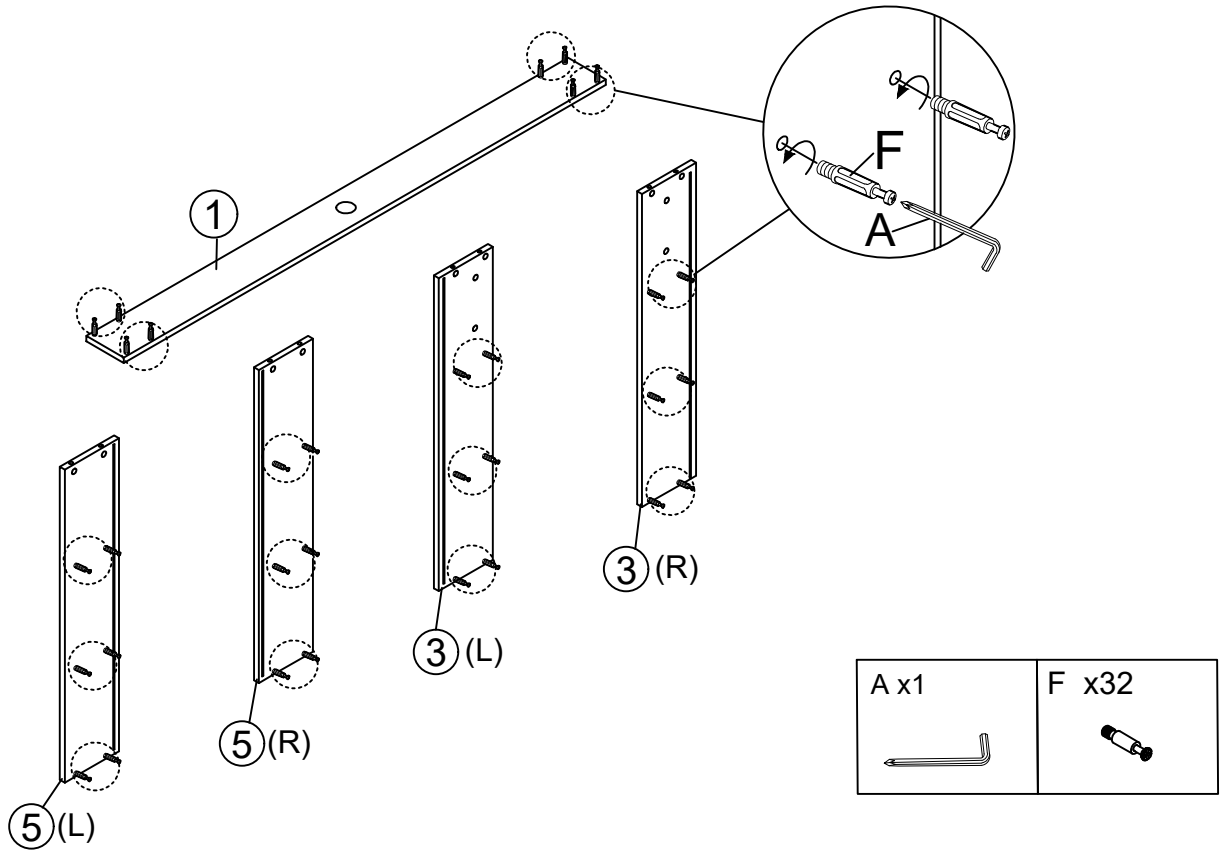

# Schritt 2 x 2

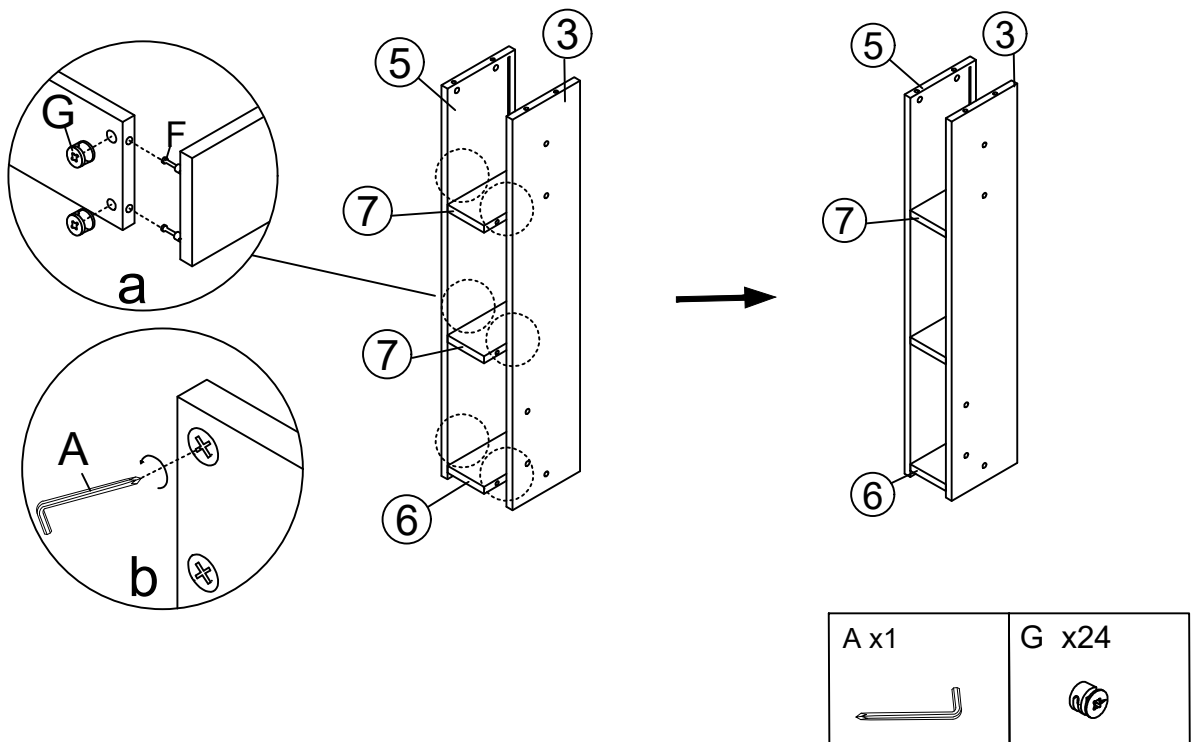

### Schritt 3

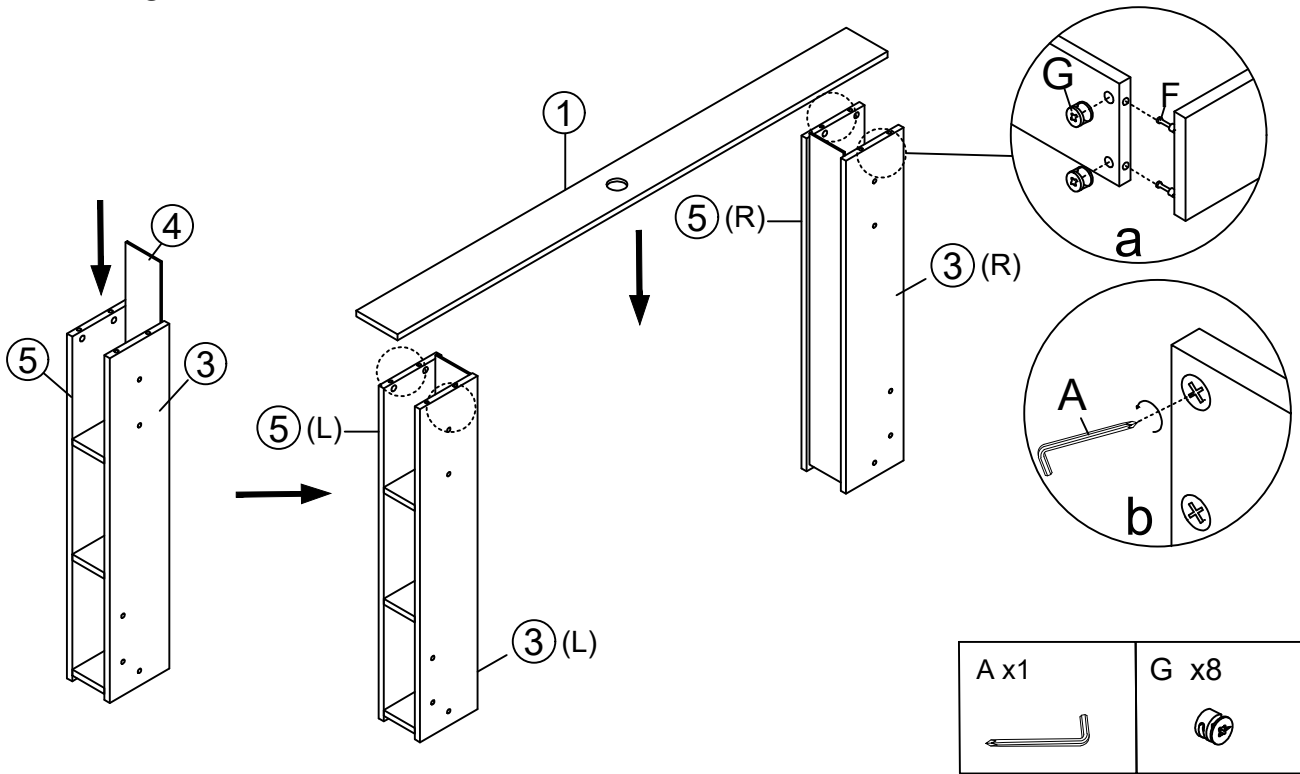



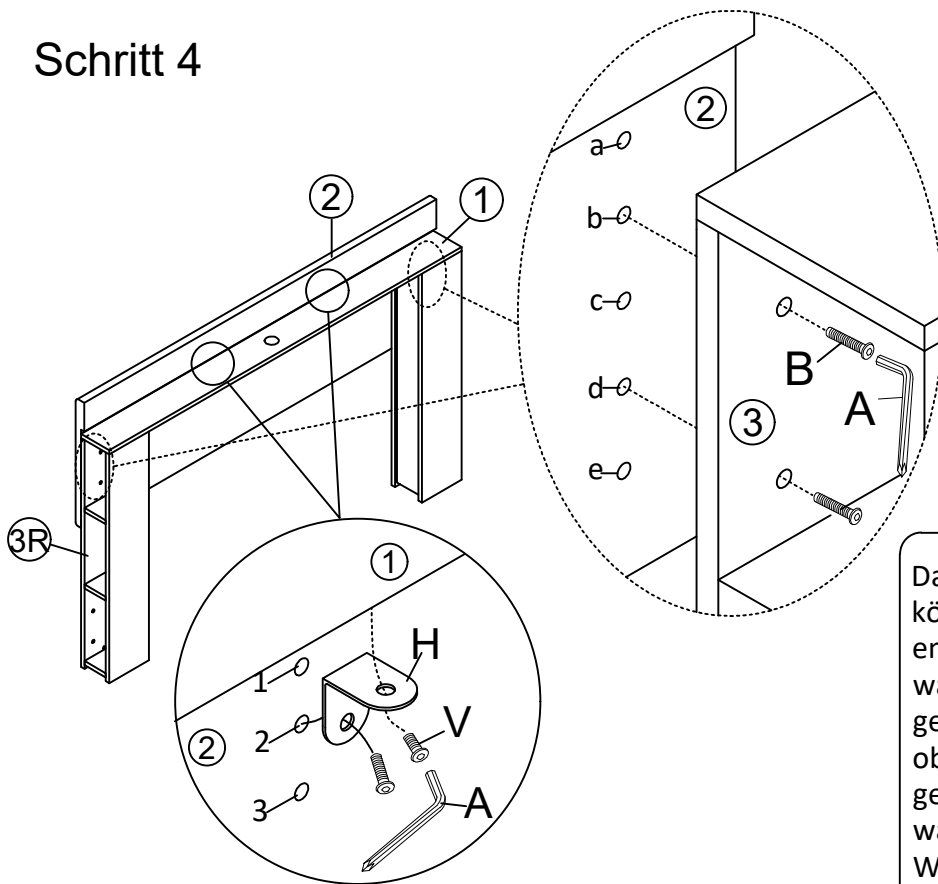

### Schritt 4







The headboard can be adjustable. You can choose the different holes according to the thickness of your mattress. If you choose the hole a and c, you must choose the hole 1 on the top. If you choose the hole b and d, you must choose the hole 2 on the top. If you choose the hole c and e, you must choose the hole 3 on the top.

Das Kopfteil kann verstellbar sein. Sie können die verschiedenen Löcher entsprechend der Dicke Ihrer Matratze wählen. Wenn Sie Loch a und c gewählt haben, müssen Sie Loch 1 oben wählen. Wenn Sie Loch b und d gewählt haben, müssen Sie Loch 2 oben wählen. Wenn Sie die Löcher c und e gewählt haben, müssen Sie das Loch 3 oben wählen.

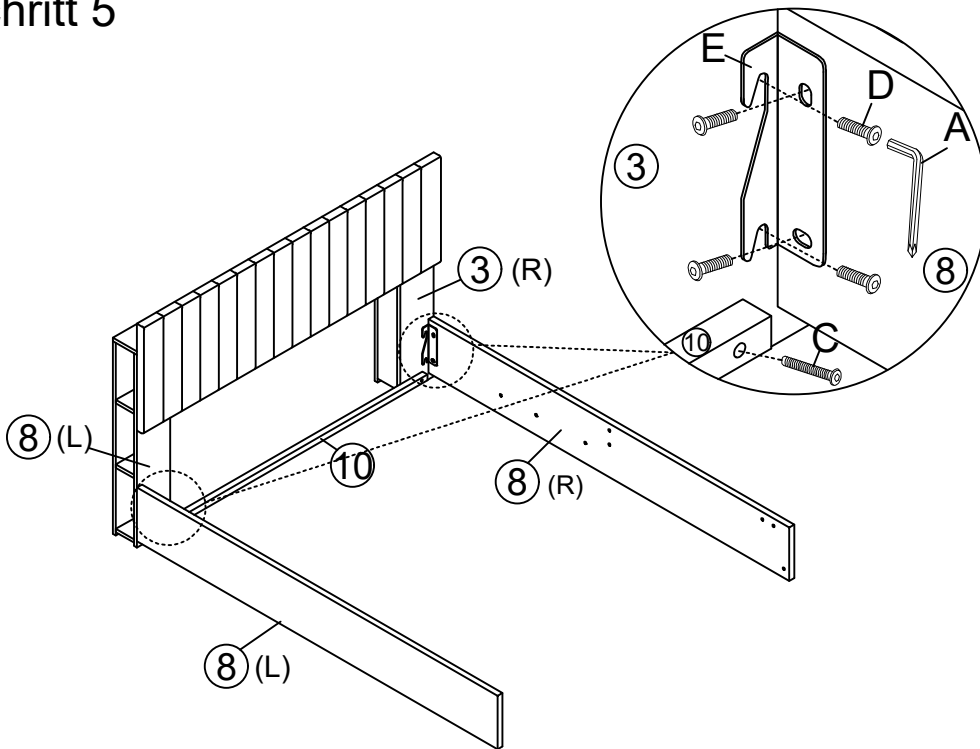
A x1	B x4	D x2	H x2	V x2
	 M8X30mm	 M8X16mm		 M8X12mm

## Schritt 5



A x1	C x2	D x8	E x2
	 M8X45mm	 M8X16mm	

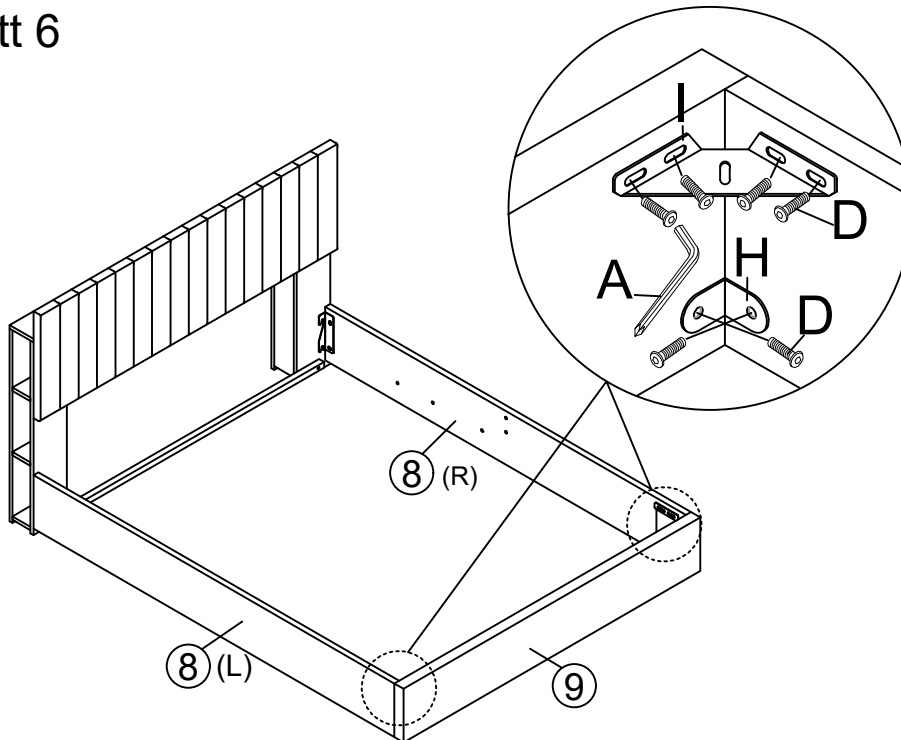

## Schritt 6



A x1	D x12	H x2	I x2
	 M8X16mm		

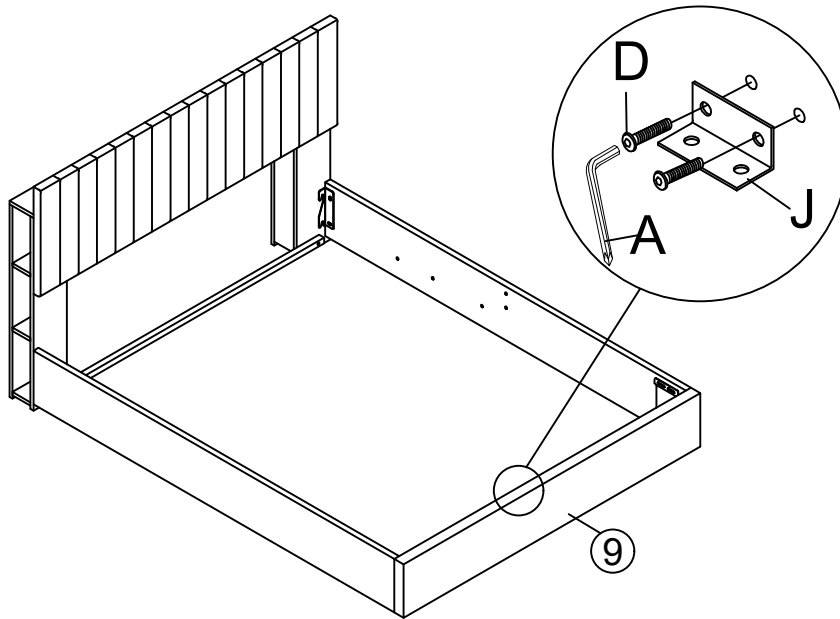

## Schritt 7

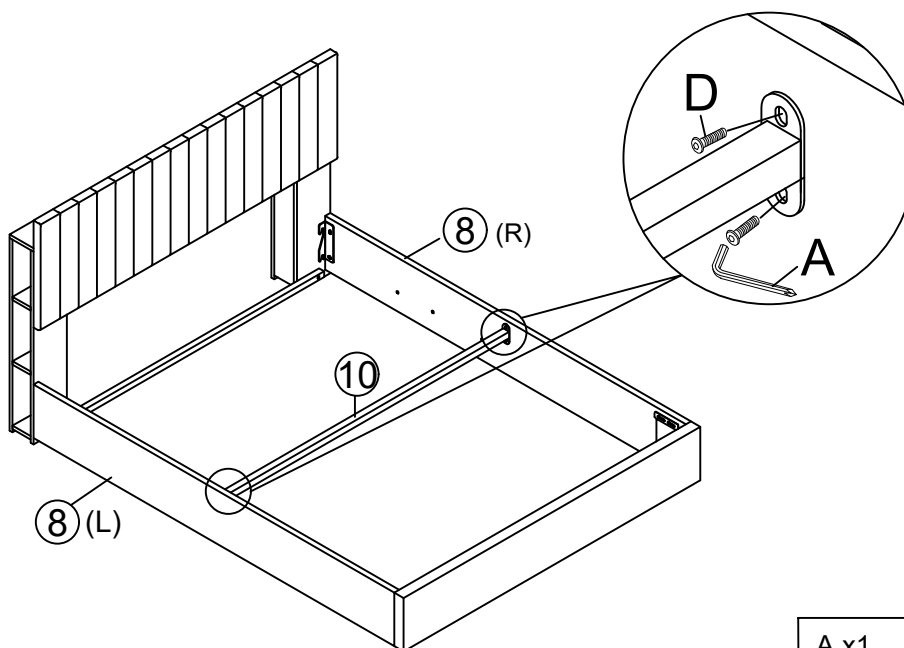

A x1 	D x2  M8X16mm	J x1 
---	---	--

## Schritt 8



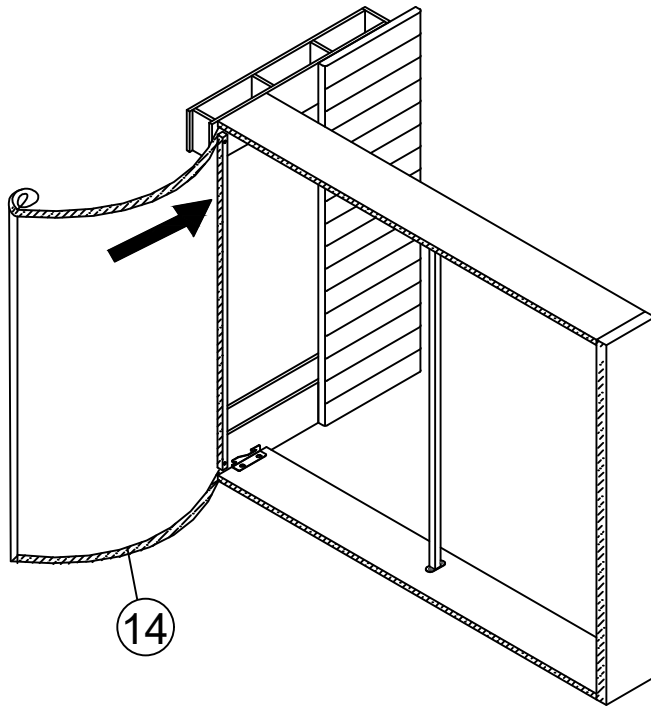

A x1 	D x4  M8X16mm
---	--

## Schritt 9

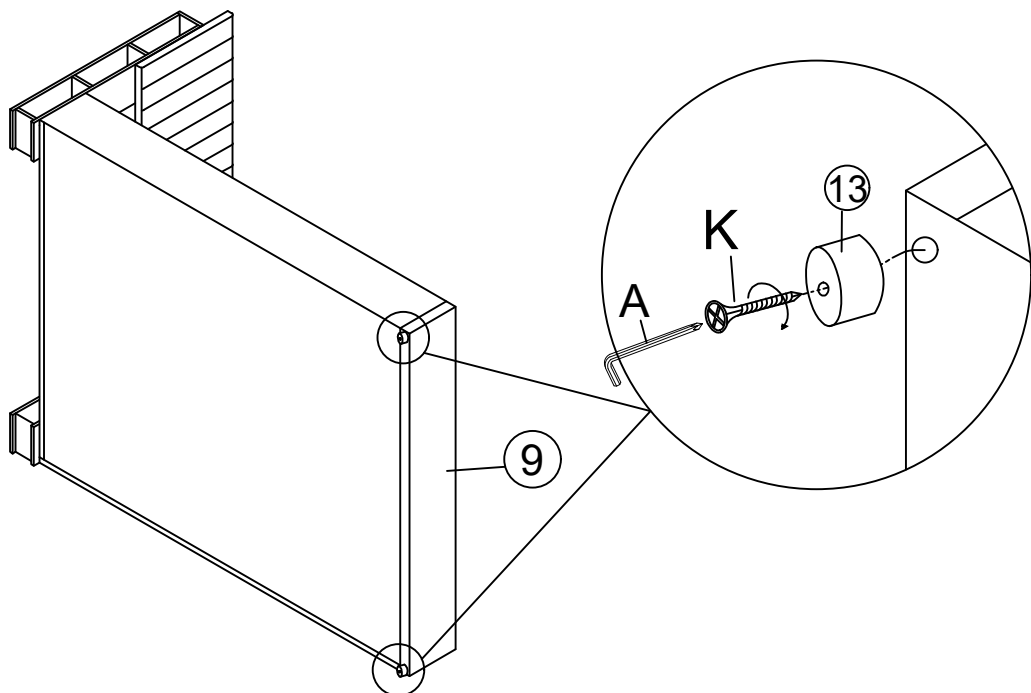

## Schritt 10



A x1	K x2
	
	M4X50mm

## Schritt 11

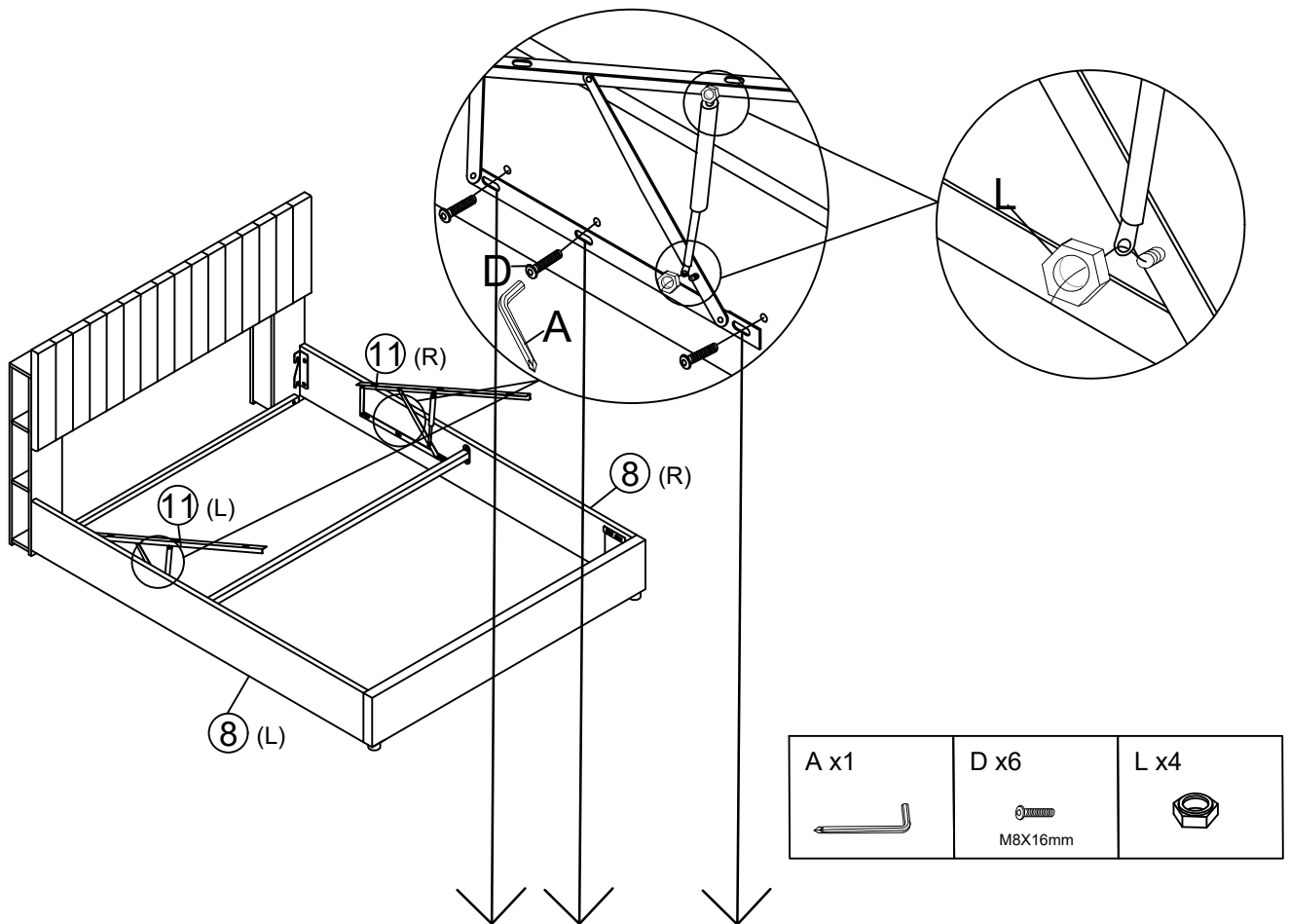

Please note that the hole position here is oval, and the screw can be adjusted back and forth. Please ensure that the position of the left and right bedside hydraulic rods is roughly always.





Please don't install one screw at the front of the hole and the other at the back of the hole, as this will affect the movement of the slat frame.

Bitte beachten Sie, dass die Lochposition hier oval ist und die Schraube hin und her verstellt werden kann. Bitte achten Sie darauf, dass die Position der linken und rechten bettseitigen Hydraulikstangen immer ungefähr ist.

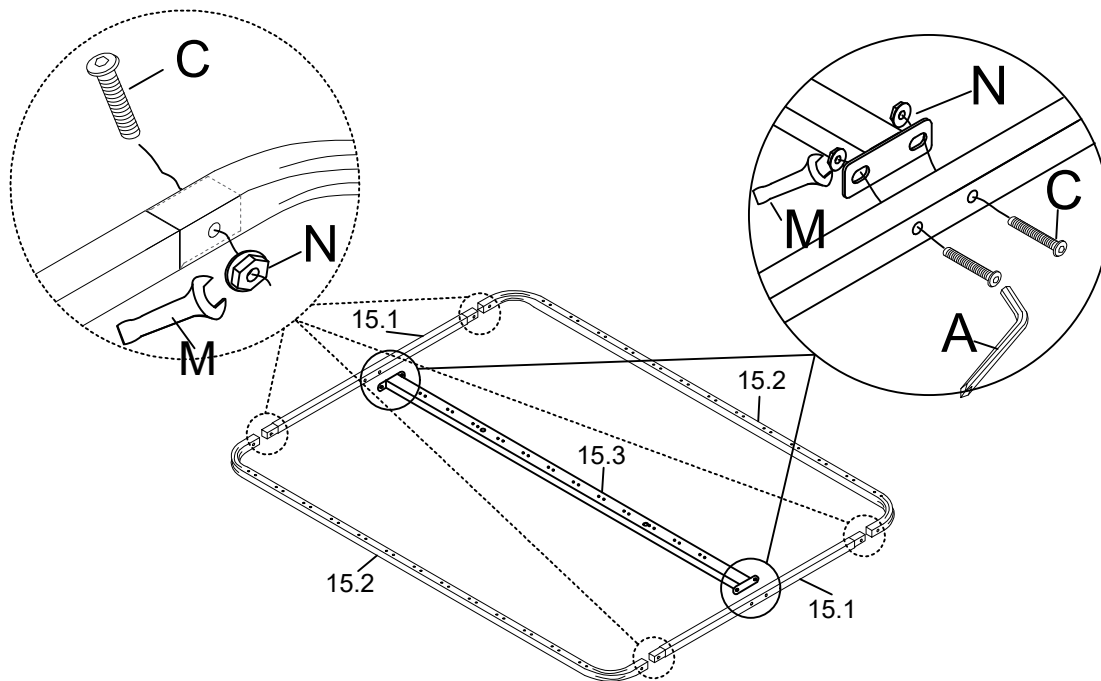
Bitte montieren Sie nicht eine Schraube vorne am Loch und die andere hinten am Loch, da dies die Bewegung des Lattenrostes beeinträchtigt.



## Schritt 12

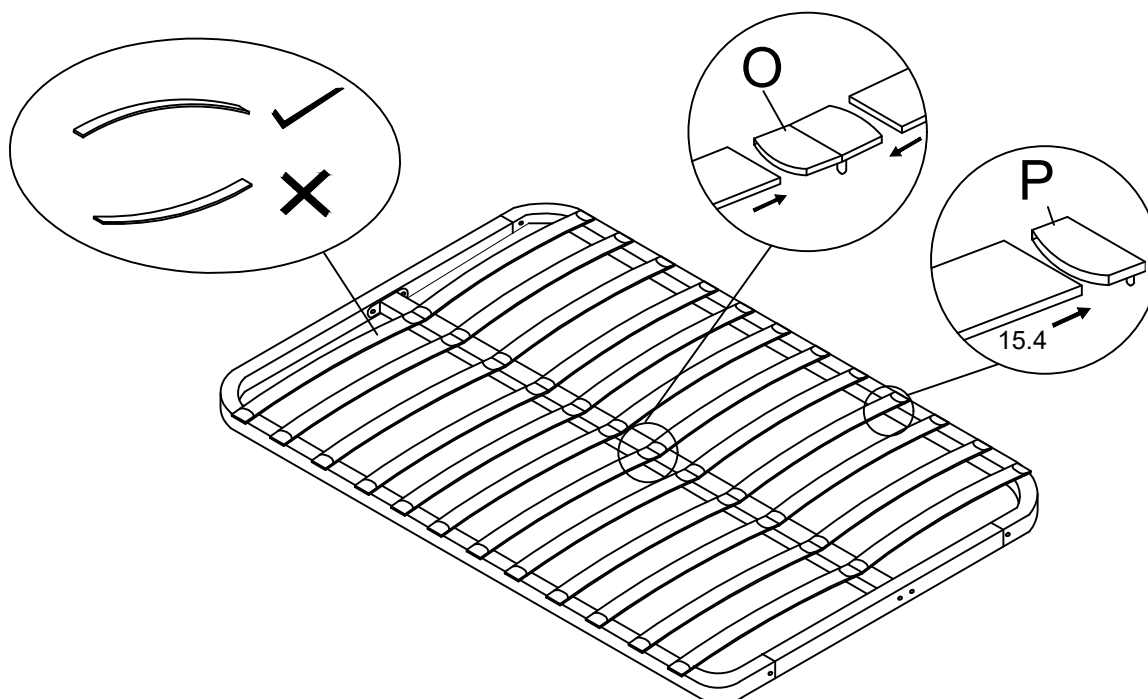

A x1	C x8 M8X45mm	N x8	M x1
			

## Schritt 13



O x12	P x24
	

# Schritt 14

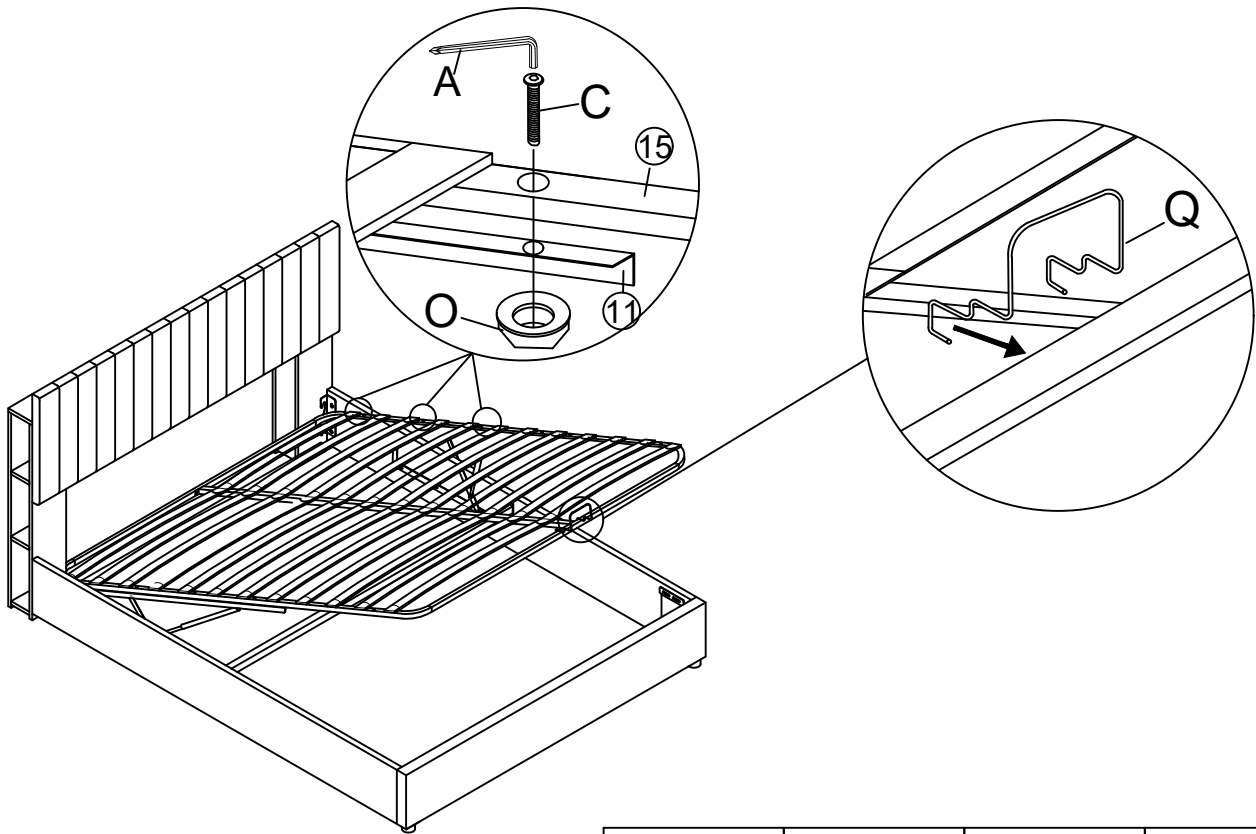

A x1	C x6 M8X45mm	N x6	Q x1

# Schritt 15

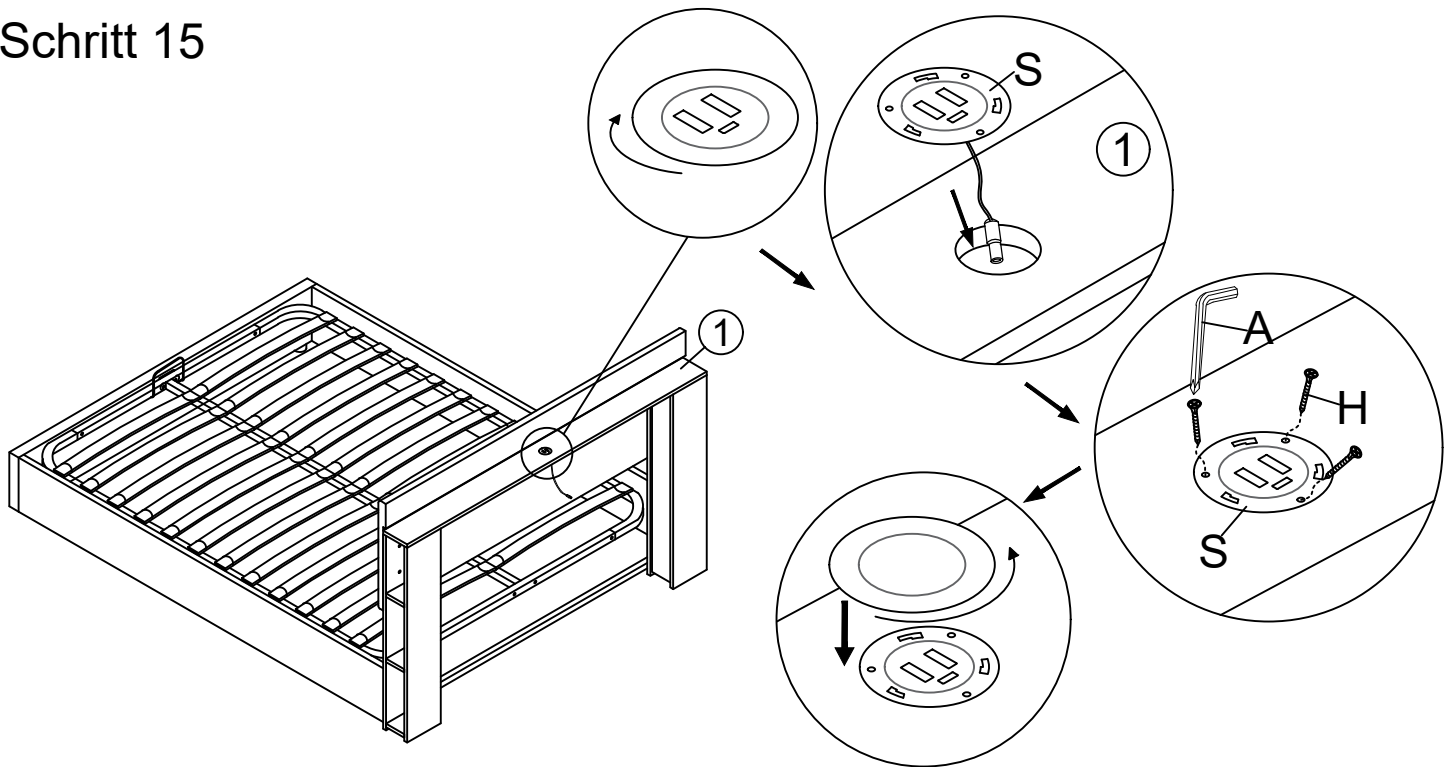

A x1	R x3 M3X16mm	S x1

# Schritt 16

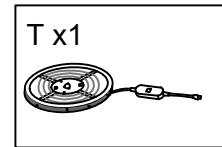
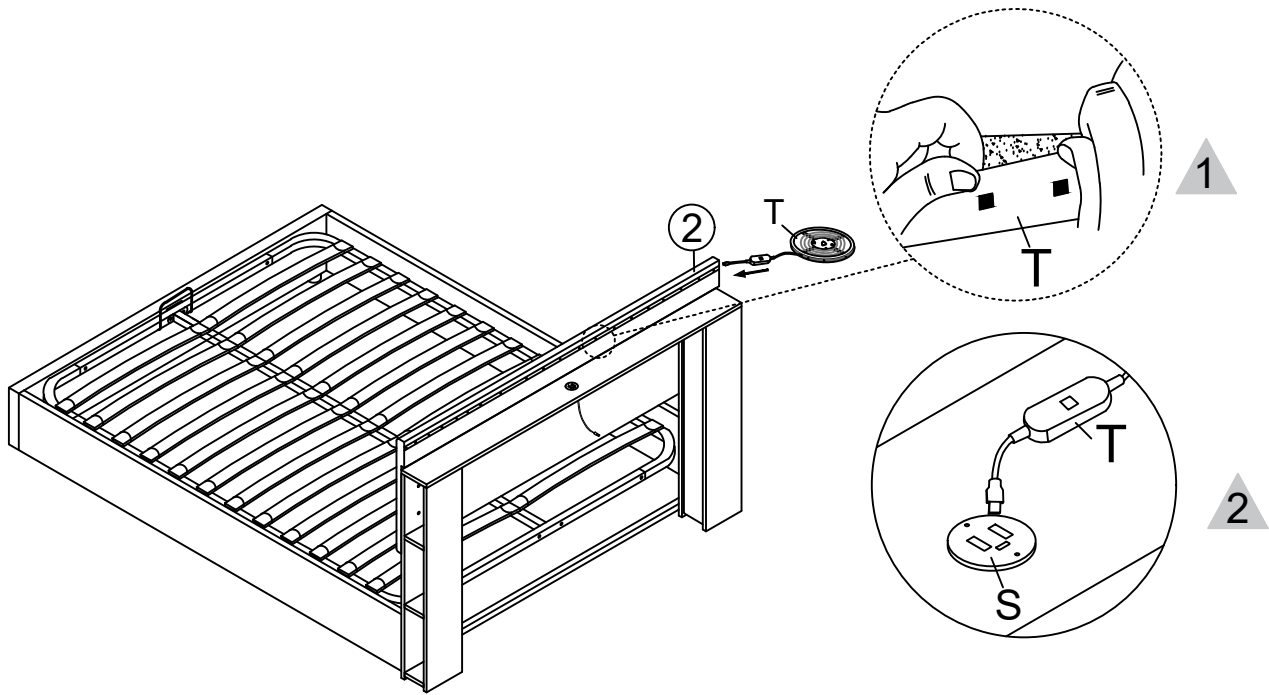

# Schritt 17

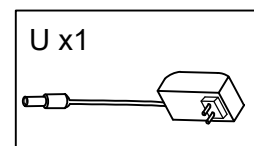
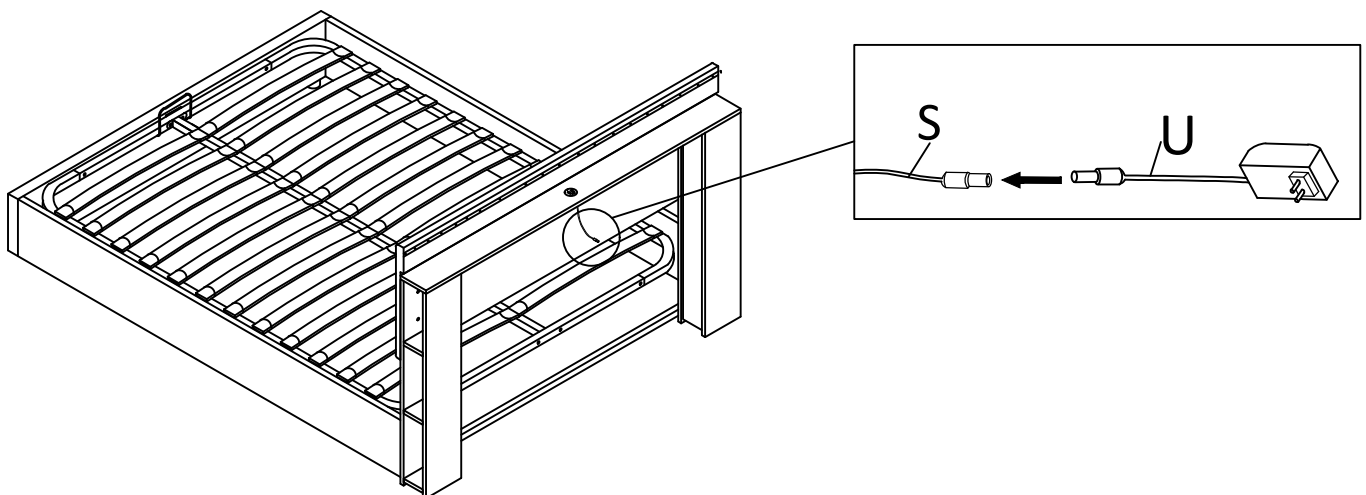

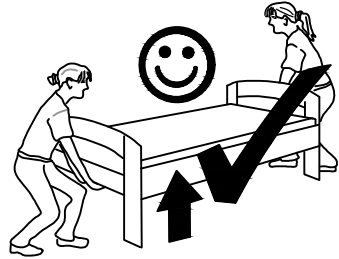
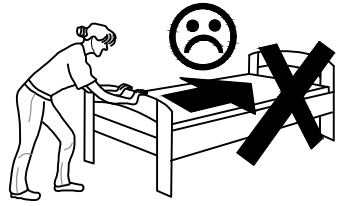
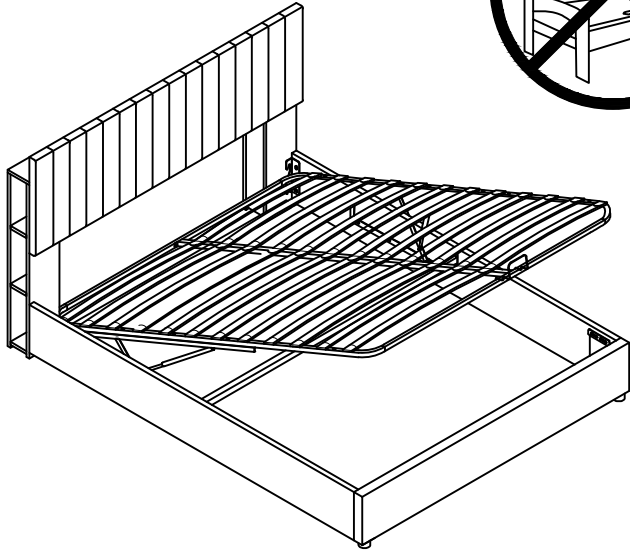

## WHY WON'T MY HYDRAULIC BED STAY DOWN?

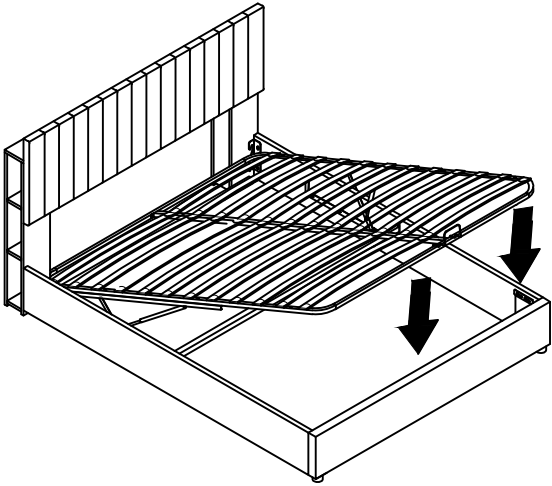

1. In fact, nine times out ten the reason why hydraulic won't close is because you need to put your mattress on top of the bed. Yep, it really is that easy. This is because the hydraulic pistons need the weight of the mattress to provide enough pressure to close your bed.

2. However, what if you've put your mattress on your bed and you're one of the unlucky ones who finds that their hydraulic bed still won't stay down? As previously mentioned, they require pressure in order to close. However, occasionally as well as placing the mattress on the bed you will initially have to apply some physical force yourself to close the bed. Don't worry you won't break it! ! ! !

## WARUM BLEIBT MEIN HYDRAULISCHES BETT NICHT UNTEN?

1. In neun von zehn Fällen liegt der Grund dafür, dass sich die Hydraulik nicht schließen lässt, darin, dass Sie Ihre Matratze oben auf das Bett legen müssen. Ja, es ist wirklich so einfach. Das liegt daran, dass die Hydraulikkolben das Gewicht der Matratze benötigen, um genügend Druck zum Schließen des Bettes zu erzeugen.

2. Was aber, wenn Sie Ihre Matratze auf Ihr Bett gelegt haben und zu den Unglücklichen gehören, die feststellen, dass ihr hydraulisches Bett trotzdem nicht unten bleibt? Wie bereits erwähnt, muss man Druck ausüben, um sie zu schließen. Gelegentlich müssen Sie jedoch nicht nur die Matratze auf das Bett legen, sondern zunächst selbst etwas Kraft aufwenden, um das Bett zu schließen. Keine Sorge, Sie werden es nicht kaputt machen! ! ! !

# LED Bluetooth controller Features

## Caractéristiques du contrôleur Bluetooth LED

### LED Bluetooth Controller Eigenschaften

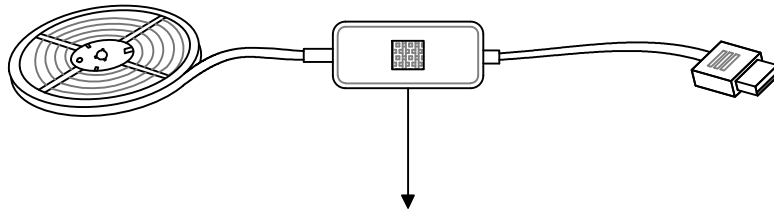

#### NOTICE:

Please scan the QR code to download the APP to control the color of the light strip.  
Please refer to the following instructions for details.

Bitte scannen Sie den QR-Code, um die APP herunterzuladen, um die Farbe des Einzelheiten entnehmen Sie bitte der folgenden Anleitung.

Veillez scanner le code QR pour télécharger l'application pour contrôler la couleur de la bande lumineuse.

Veillez consulter les instructions ci-dessous pour plus de détails.

Click to show the lamp list

Cliquez pour afficher la liste des lumières  
Klicken Sie, um die Liste der Lichter anzuzeigen

Switch the color wheel  
Basculer la roue des couleurs  
Farbrad wechseln

Display the RGB value Click to manual  
Afficher les valeurs RVB Cliquez pour manuellement  
RGB-Werte anzeigen Klicken Sie manuell

Adjustment view  
Ajuster la vue  
Ansicht anpassen

Click to shift the interface

Cliquez sur l'interface mobile Ansicht  
Klicken Sie, um die Schnittstelle zu wechseln

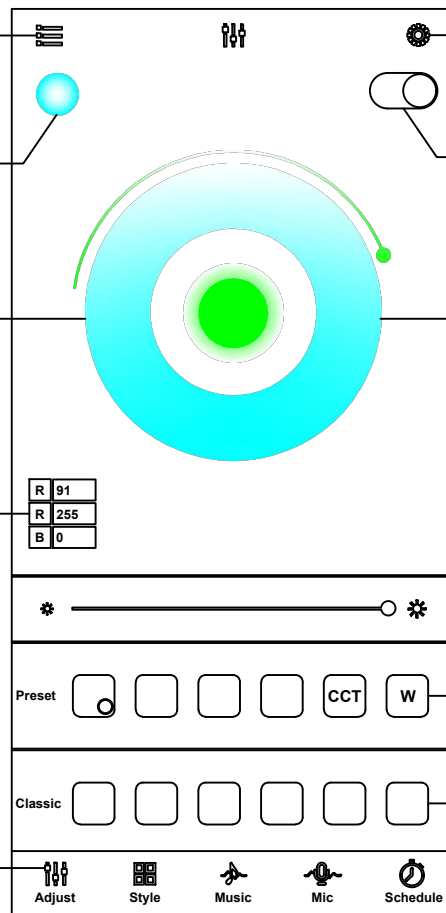

Click to display setting view

Cliquez pour afficher la vue des paramètres  
Klicken Sie, um die Einstellungsansicht anzuzeigen

Lamp switch button  
Bouton interrupteur lumière  
Taste für Lichtschalter

Adjust the color  
Ajuster la couleur  
Farbe anpassen

Click square icon to  
Cliquez sur l'icône du carré pour  
Klicken Sie auf das quadratische Symbol, um

R	91
R	255
B	0



Preset     CCT W

Classic

Adjust Style Music Mic Schedule

# LED Bluetooth controller Features

## Caractéristiques du contrôleur Bluetooth LED

### LED Bluetooth Controller Eigenschaften

#### Product Features :

LED Bluetooth controller is directly via mobile phone control remote distance can reach 20m without the need to set up, easy to connect open the software within 5 seconds you can automatically connect the controller · Flow the rhythm of the music changes · Group control · Brightness, speed addition and subtraction · Maximum can be 10 meters RGB(W) strip · The software shows that the text is based on the language of the mobile phone set up automatic transformation of Chinese and English Animation Effect: · Colorful gradient ● All kinds of monochrome, double color gradient ● All kinds of monochrome, double color, colorful flashing Follow the rhythm of the music changes  
Product Parameters: · Bluetooth: BLE V4.2 · Input Voltage: 4.5~26V · Working Temp: -25~75  
· Size: 43\*22\*11mm · Weight: 30g · Max Power: 144W(24V)

#### Caractéristiques du produit:

Le contrôleur Bluetooth LED est contrôlé directement via le téléphone portable La distance à distance peut atteindre 20m Aucun réglage requis, connexion facile Ouvrez le logiciel pour se connecter automatiquement au contrôleur dans les 5 secondes · Changement de rythme de la musique fluide · Contrôle de groupe · Luminosité, augmentation et diminution de vitesse · Jusqu'à 10 mètres barres RVB (W) · Le logiciel affiche le texte Convertir automatiquement les effets d'animation chinois et anglais selon les paramètres de langue du téléphone portable: · Dégradé coloré ● Divers dégradés monochrome et bicolore ● Divers clignotements monochrome, bicolore et colorés suivent le rythme de la musique changes Paramètres du produit: · Bluetooth: BLE V4.2 · Tension d'entrée: 4,5 ~ 26 V · Température de fonctionnement: -25 ~ 75 · Taille: 43 \* 22 \* 11 mm · Poids: 30 g · Puissance maximale: 144 W (24 V)

#### Produktmerkmale:

Der LED-Bluetooth-Controller wird direkt über das Mobiltelefon gesteuert. Die Fernentfernung kann bis zu 20 m erreichen. Keine Einstellung erforderlich, einfach zu verbinden. Öffnen Sie die Software, um den Controller automatisch innerhalb von 5 Sekunden zu verbinden · Rhythmusänderungen der fließenden Musik · Gruppensteuerung · Helligkeit, Geschwindigkeitserhöhung und -verringerung · Maximal 10 Meter RGB(W)-Streifen · Software zeigt Text, um den Animationseffekt zwischen Chinesisch und Englisch entsprechend den Spracheinstellungen des Mobiltelefons automatisch umzuwandeln: · Bunter Farbverlauf ● Verschiedene einfarbige und zweifarbige Farbverläufe ● Verschiedene einfarbige, zweifarbige und farbenfrohe Blinkungen folgen dem Rhythmus der Musik changes Produktparameter: · Bluetooth: BLE V4.2 · Eingangsspannung: 4,5 ~ 26 V · Betriebstemperatur: -25 ~ 75 · Größe: 43 \* 22 \* 11 mm · Gewicht: 30 g · Maximale Leistung: 144 W (24 V)

# Verification of Compliance

Verification No.:	MK24070005P01-C01
Name and address of Applicant:	<b>Shenzhen Aoli Optoelectronics Co., Ltd</b> 5th Floor, Building 3, Haitian Lanyu Science and Technology Park, Shilong Community, Shiyan Street, Bao'an District, Shenzhen
Name and address of Manufacturer:	<b>Shenzhen Aoli Optoelectronics Co., Ltd</b> 5th Floor, Building 3, Haitian Lanyu Science and Technology Park, Shilong Community, Shiyan Street, Bao'an District, Shenzhen
Product name:	<b>Embedded USB port</b>
Product model(s):	12vA+c, 5vA+c
Product trademark:	N/A

This verification confirms that the product meets the requirements of the following standard. The conformity was demonstrated based on following standard(s) listed by European Commission as harmonized with Directive RoHS 2.0 Directive (EU) 2015/863 and (EU)2017/2102 amending Annex II to Directive 2011/65/EU

IEC 62321-1:2013	IEC 62321-3-1:2013
IEC 62321-4:2013/AMD1:2017	IEC 62321-5:2013
IEC 62321-6:2015	IEC 62321-7-1:2015
IEC 62321-7-2:2017	IEC 62321-8:2017
IEC 62321-2:2014	

*The verification has been carried out in accordance with individual rules and conditions agreed with the applicant. Evaluation has been carried out in accordance with:*

Test report(s) No.:	MK24070005P01-C01
Test conducted by:	TMC Testing Services (Shenzhen) Co., Ltd.
Verification issue date:	July 11, 2024

#### Notes:

*This verification refers to the above mentioned product and its conformity in regards of above mentioned standard(s) was proven on test sample.*

*This verification does not imply meeting all essential requirements, assessment of the series-production or any other restricted Notified Bodies conformity assessment procedure appropriate for the product.*

*This verification holder shall use this verification in connection to verification of conformity and technical data relevant for the product the verification was issued.*

#### **TMC Testing Services (Shenzhen) Co., Ltd.**

t:86-755-86642861 cert@tmc-lab.com www.tmc-lab.com

1st Floor, Block A1, Zone A, Xinshidai Gongrong Industrial Park, No. 2, Shihuan Road, Shiyan Street, Baoan District, Shenzhen, China



**Lab Director**  
Vivian Jiang



# Verification of Compliance

Verification No.:	MK24030235P01-S01
Name and address of Applicant:	<b>Shenzhen Hongzhengyu Technology Co., LTD</b> Shenzhen baoan district rock street industrial science and technology industrial park of 2 Haitian lanyu 3 5 floor of A
Name and address of Manufacturer:	<b>Shenzhen Hongzhengyu Technology Co., LTD</b> Shenzhen baoan district rock street industrial science and technology industrial park of 2 Haitian lanyu 3 5 floor of A
Product name:	<b>LED Lamp Strip</b>
Rated:	DC5V, 2A, Max.10W HZY-2835-120D-12V, HZY-2835-30D-5V, HZY-2835-60D-5V, HZY-2835-120D-5V, HZY-2835-60D-12V, HZY-2835-60D-24V, HZY-2835-120D-24V, HZY-2835RGB-60D-5V, HZY-2835RGB-60D-12V, HZY-5050-30D-5V, HZY-5050-60D-5V, HZY-5050-30D-12V, HZY-5050-60D-12V, HZY-5050-60D-24V, HZY-5050RGB-30D-5V, HZY-5050RGB-60D-5V, HZY-5050RGB-30D-12V, HZY-5050RGB-60D-12V, HZY-5050RGB-60D-24V
Product model(s):	
Product trademark:	N/A

This verification confirms that the product meets the requirements of the following standard.  
The conformity was demonstrated based on following standard(s) listed by European Commission as harmonized with LVD Directive 2014/35/EU.

EN IEC 60598-2-1:2021;  
EN IEC 60598-1:2021+ A11:2022

*The verification has been carried out in accordance with individual rules and conditions agreed with the applicant. Evaluation has been carried out in accordance with:*

Test report(s) No.:	MK24030235P01-S01
Test conducted by:	TMC Testing Services (Shenzhen) Co., Ltd.
Verification issue date:	April 9, 2024

**Notes:**

*This verification refers to the above mentioned product and its conformity in regards of above mentioned standard(s) was proven on test sample.*

*This verification does not imply meeting all essential requirements, assessment of the series-production or any other restricted Notified Bodies conformity assessment procedure appropriate for the product.*

*This verification holder shall use this verification in connection to Verification of Compliance and technical data relevant for the product the verification was issued.*

**TMC Testing Services (Shenzhen) Co., Ltd.**

t:86-755-86642861 cert@tmc-lab.com www.tmc-lab.com

1/F., Block A, Xinshidai Gongrong Industrial Park, No. 2, Shihuan Road, Shilong Community, Shiyan Street, Baoan District, Shenzhen, China



Dawen Xu

Lab Director  
Dawen Xu





# CERTIFICATE OF CONFORMITY

## Electromagnetic Compatibility (EMC) Directive 2014/30/EU

This Certificate of Conformity is hereby issued to the product designated below:

**Certificate No.** ..... : 24EP01101E01  
**Report No.** ..... : EP2401101E01  
**Date Issue.** ..... : 2024-04-28  
**Applicant's name** ..... : Guangdong Sangu Technology Co., Ltd  
**Address** ..... : 402, Chuangye building, 8-28, Shaqi community Central Road, Xinqiao street, Bao'an District, Shenzhen.  
**Manufacturer's name** ..... : Guangdong Sangu Technology Co., Ltd  
**Address** ..... : 402, Chuangye building, 8-28, Shaqi community Central Road, Xinqiao street, Bao'an District, Shenzhen.  
**Product Description** ..... : POWER ADAPTER  
**Model(s)/Type References** : SG-050yyyyz, GA-050yyyyz, GAT-050yyyyz, HZ-050yyyyz, SG-050yyyyAz, GA-050yyyyAz, GAT-050yyyyAz, HZ-050yyyyAz, SG-050yyyyAzC, GA-050yyyyAzC, GAT-050yyyyAzC, HZ-050yyyyAzC, SG-xxxyyyy12Az (xxx, yyyy, z are variables, appendix for details)  
**Parameters** ..... : See appendix for details  
**Standard(s)** ..... : EN 55032:2015+A11:2020+A1:2020  
EN 55035:2017+A11:2020  
EN IEC 61000-3-2:2019+A1:2021  
EN 61000-3-3:2013+A1:2019+A2:2021

On the basis of the referenced test report(s), sample(s) tested of the above product have been found to comply with the standards harmonized with the directives listed on this verification at the time the tests were carried out. Other standards and Directives may be relevant to the product. This verification is part of the full test report(s) and should be read in conjunction with it(them).

Once compliance with all product relevant CE mark directives are verified, including any relevant e.g. risk assessment and production control, the manufacturer may indicate compliance by signing a Declaration of Conformity themselves and applying the mark to products identical to the tested sample(s).

Approved By

.....  
Eric Liu  
Director of engineering department



Dongguan Pubiao Testing Technology Co., Ltd

No. 3, 1/F., Building A, No.30, Minghua Road, Juzhou, Shijie, Dongguan, Guangdong, China

Tel: +86 769 81813516 E-mail: service@pubiaotest.com Web: www.pubiaotest.com



# CERTIFICATE OF CONFORMITY

Electromagnetic Compatibility (EMC) Directive 2014/30/EU

Appendix of Certificate No.: 24EP01101E01

Table A: Definition of variables

Variable	Range of variable	Content
xxx	050-240	3 digits, indicates 10 times of output voltage in V and in step of 0.1V. eg. 050=5.0V, 240=24.0V.
yyyy	0100-2100	4 digits, indicates 1000 times of output current in A and in step of 0.01A. eg. 0100=0.1A, 2100=2.1A.
z	E, B	One capital letter representing the plug type for different countries. E represents European plug and Russian plug; B represents British plug.

Table B: Model list and input / output ratings

Model	Rated input	Rated output			Transformer
		Voltage range (VDC)	Current range (A)	Max. Power (W)	
SG-050yyyyz, GA-050yyyyz, GAT-050yyyyz, HZ-050yyyyz, SG-050yyyyAz, GA-050yyyyAz, GAT-050yyyyAz, HZ-050yyyyAz, SG-050yyyyAzC, GA-050yyyyAzC, GAT-050yyyyAzC, HZ-050yyyyAzC,	100-240V~, 50/60Hz, 0.3A Max.	5.0	0.1-2.0	10.0	EF1510
SG-xxxxyyy12Az	100-240V~, 50/60Hz, 0.6A Max.	5.0-5.5	0.10-2.1	11.55	EF1510-1
		5.6-12.0	0.10-2.0	12.00	
		12.1-24.0	0.10-1.0	12.00	





Dongguan Pubiao Testing Technology Co., Ltd



No. 3, 1/F., Building A, No.30, Minghua Road, Juzhou, Shijie, Dongguan, Guangdong, China

Tel: +86 769 81813516 E-mail: service@pubiaotest.com Web: www.pubiaotest.com



Importeur	Decobus Handel GmbH
Adresse	Innungsstraße 9, 21244 Buchholz,Deutschland
Email/URL	<a href="https://www.decobusgroup.de">https://www.decobusgroup.de</a>
Hersteller	Guandong sangu Technology Co., LTD
Adresse	402 Chuangye building,8-28,Shaqi community Central Road,Xingqiao street Bao'an District,Shenzhen
Email/URL	<a href="mailto:965385037@qq.com">965385037@qq.com</a>
Partienummer	SG 120200024AE
Hergestellt in	China
	Decobus Handel GmbH Innungsstraße 9, 21244 Buchholz,Deutschland <a href="http://www.decobusgroup.de">www.decobusgroup.de</a>



 Product Name:Power Adapter  
 Model:CG 120200024AE  
 Rated voltage:DC12  
 Rated frequency:50-60HZ  
 Power:24W

Importeur	Decobus Handel GmbH
Adresse	Innungsstraße 9, 21244
Email/URL	<a href="https://www.decobusgroup.de">https://www.decobusgroup.de</a>
Hersteller	Shenzhen Hongzhengyu Technology Co.,
Adresse	Shenzhen baoan district rock street industrial science and technology industrial park of 2 Haitian lanyu 3 5 floor of
Email/URL	<a href="mailto:965385037@qq.com">965385037@qq.com</a>
Partienummer	XH-24S
Hergestellt in	China
	Decobus Handel GmbH Innungsstraße 9, 21244 Buchholz,Deutschland <a href="http://www.decobusgroup.de">www.decobusgroup.de</a>



 Product Name:LED light strip  
 Model:HZY-5050RGB-30D-12V  
 Rated voltage:DC12V  
 Rated frequency:0HZ  
 Power:5W/M

Importeur	Decobus Handel GmbH
Adresse	Innungsstraße 9, 21244
Email/URL	<a href="https://www.decobusgroup.de">https://www.decobusgroup.de</a>
Hersteller	Shenzhen Aoli Optoelectronics Co., LTD
Adresse	5th floor,Building3,Haitianlanyu Technology Park,shiyao,Bao'an District,Shenzhen
Email/URL	<a href="mailto:965385037@qq.com">965385037@qq.com</a>
Partienummer	Embedded USB port
Hergestellt in	China
	Decobus Handel GmbH Innungsstraße 9, 21244 Buchholz,Deutschland <a href="http://www.decobusgroup.de">www.decobusgroup.de</a>



 Product Name:Embedded USB port  
 Model:12V A+C  
 Rated voltage:DC12  
 Rated frequency:50-60HZ



**FR**  
 Cet appareil,  
 ses cordons,  
 et batterie  
 se recyclent

À DÉPOSER  
 EN MAGASIN

À DÉPOSER  
 EN DÉCHÈTERIE

OU

Points de collecte sur [www.quefairedemesdechets.fr](http://www.quefairedemesdechets.fr)  
 Privilégiez la réparation ou le don de votre appareil !