

Montageanleitung | Instructions de montage Assembly Instructions | Instrucciones de montaje

SKU NUMBER: N616P381027/N616P381028
N616P381029

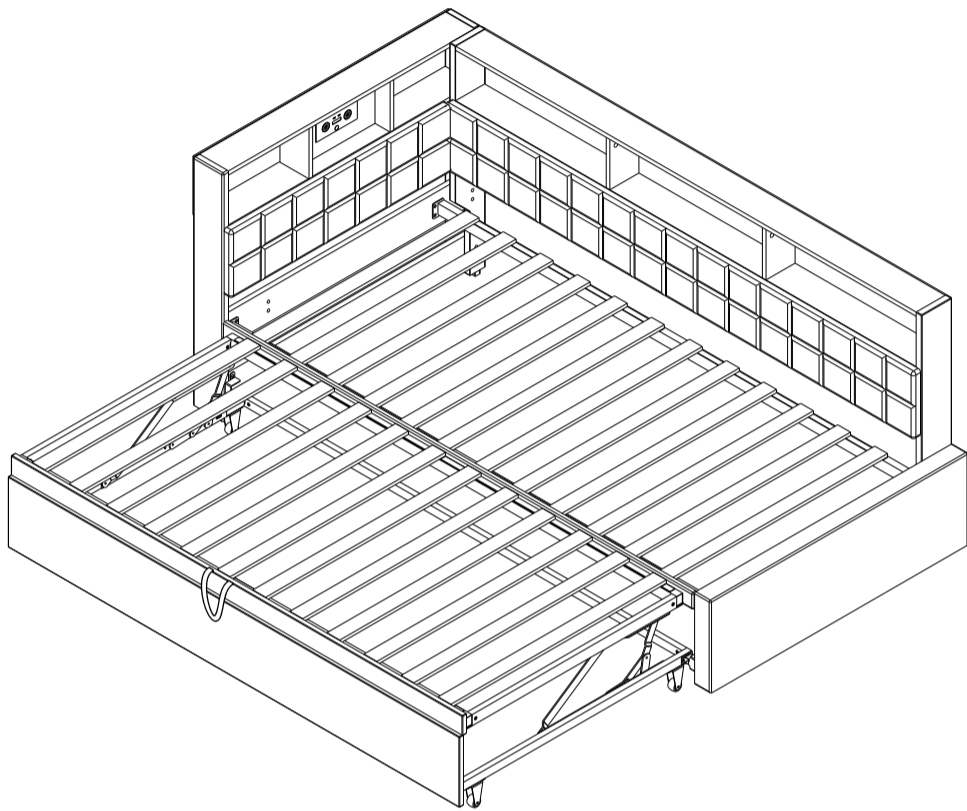

L

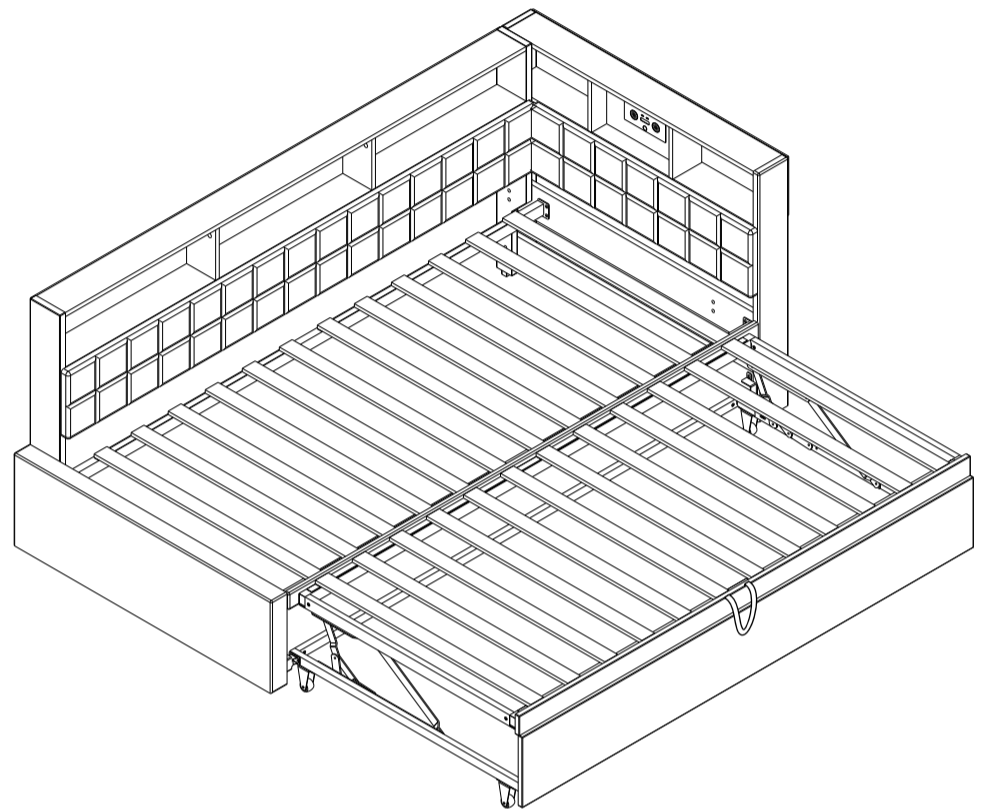

R

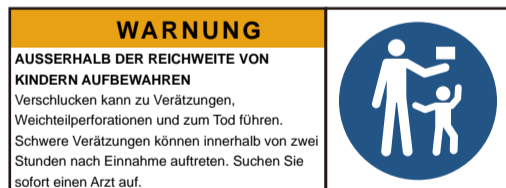

GB This set comes in 3 boxes. If you do not receive a full set of 3 boxes, please contact our customer service.

DE Dieses Set wird in 3 Schachteln geliefert. Wenn Sie nicht ein komplettes Set von 3 Boxen erhalten, kontaktieren Sie bitte unseren Kundenservice.

FR Ce set est livré en 3 boîtes. Si vous ne recevez pas un jeu complet de 3 boîtes, veuillez contacter notre service clientèle.

English

IMPORTANT ! KEEP FOR FUTURE REFERENCE : READ CAREFULLY

- To be assembled by an adult. Assembly must be checked by an adult before use
- WARNING ! Keep all screws, small parts and plastic bags out of the reach of children
- Properly identify all parts before assembling
- Never use your item if any of its parts are broken or missing
- Should any problems arise, please contact our After Sales Service
- Manufacturer's instructions shall be followed at all times
- Care: Clean with a soft, dry cloth. In case of larger stains, carefully rub with a slightly damp, non-abrasive sponge
- Avoid the risk of fire by not placing furniture near sources of ignition or hot items
- Do not jump on the bed

Deutsch

WICHTIG ! ZUM SPÄTEREN NACHSCHLAGEN AUFBEWAHREN: SORGFÄLTIG LESEN

- Muss von einem Erwachsenen zusammengebaut werden. Der Zusammenbau muss vor dem Gebrauch von einem Erwachsenen überprüft werden
 - WARNUNG! Bewahren Sie alle Schrauben, Kleinteile und Plastikbeutel außerhalb der Reichweite von Kindern auf
 - Kennzeichnen Sie vor dem Zusammenbau alle Teile richtig
 - Benutzen Sie Ihren Artikel niemals, wenn Teile gebrochen sind oder fehlen
 - Sollten Probleme auftreten, wenden Sie sich bitte an unseren Kundendienst
 - Die Anweisungen des Herstellers sind stets zu befolgen
 - Pflege: Mit einem weichen, trockenen Tuch reinigen. Bei größeren Flecken vorsichtig mit einem leicht feuchten, nicht scheuernden Schwamm abreiben. nicht scheuernden Schwamm
 - Vermeiden Sie die Gefahr eines Brandes, indem Sie die Möbel nicht in der Nähe von Zündquellen oder heißen Gegenständen aufstellen
 - Nicht auf das Bett springen

Français

IMPORTANT ! CONSERVER POUR RÉFÉRENCE ULTÉRIEURE : LIRE ATTENTIVEMENT

- Le montage doit être effectué par un adulte. Le montage doit être vérifié par un adulte avant Utilisation
 - ATTENTION ! Tenir les vis, les petites pièces et les sachets en plastique hors de portée des enfants
 - Identifiez correctement toutes les pièces avant de les assembler
 - N'utilisez jamais votre article si l'une de ses pièces est cassée ou manquante
 - En cas de problème, veuillez contacter notre service après-vente
 - Les instructions du fabricant doivent être respectées à tout moment
 - Entretien : nettoyer avec un chiffon doux et sec. En cas de taches plus importantes, frotter soigneusement avec une éponge non abrasive légèrement humide. légèrement humide et non Abrasive
 - Évitez les risques d'incendie en ne plaçant pas les meubles à proximité de sources d'inflammation ou d'objets chauds
 - Ne pas sauter sur le lit

Italiano

IMPORTANTE! CONSERVARE PER RIFERIMENTO FUTURO: LEGGERE ATTENTAMENTE

- Deve essere assemblato da un adulto. L'assemblaggio deve essere controllato da un adulto prima dell'uso
- **ATTENZIONE!** Tenere tutte le viti, le piccole parti e i sacchetti di plastica fuori dalla portata dei bambini
- Identificare correttamente tutte le parti prima dell'assemblaggio
- Non utilizzare mai l'articolo se alcune parti sono rotte o mancanti
- In caso di problemi, si prega di contattare il nostro Servizio Post Vendita
- Le istruzioni del produttore devono essere sempre seguite
- Cura: Pulire con un panno morbido e asciutto. In caso di macchie più estese, strofinare accuratamente con una spugna leggermente umida e non spugna leggermente umida e non abrasiva
- Evitare il rischio di incendio, non collocando i mobili vicino a fonti di accensione o a oggetti caldi
- Non saltare sul letto

Español

¡ IMPORTANTE ! CONSERVELO PARA FUTURAS CONSULTAS: LEA ATENTAMENTE

- Debe ser montado por un adulto. El montaje debe ser comprobado por un adulto antes del uso
- ADVERTENCIA** Mantenga todos los tornillos, piezas pequeñas y bolsas de plástico fuera del alcance de los niños.
- Identifique correctamente todas las piezas antes de montarlas
 - Nunca utilice su artículo si alguna de sus piezas está rota o falta
 - Si surge algún problema, póngase en contacto con nuestro Servicio Postventa
 - Las instrucciones del fabricante deben seguirse en todo momento
 - Cuidado: Limpiar con un paño suave y seco. En caso de manchas más grandes, frote cuidadosamente con una esponja no abrasiva ligeramente humedecida.
 - Evite el riesgo de incendio no colocando los muebles cerca de fuentes de ignición u objetos calientes.
 - No saltar sobre la cama.

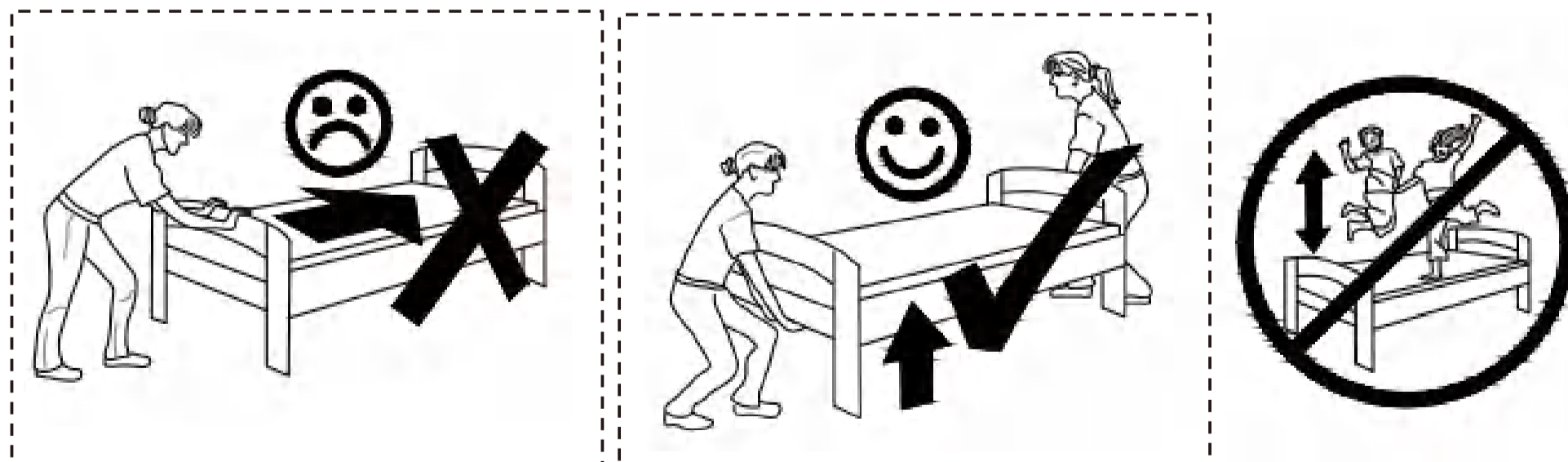

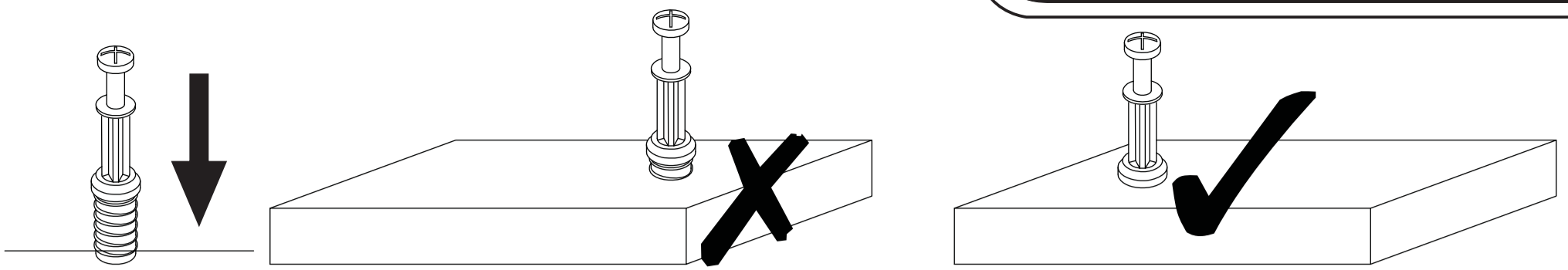

EN_QUICKFIT: Tighten quickfit until shoulder is flush with panel. Do not overtighten or undertighten.

FR_RACCORD RAPIDE: Faites serrer le raccord rapide jusqu'à ce que l'épaulement soit parfaitement encastré dans le panneau. Il ne faut ni trop serrer ni insuffisamment serrer.

ES_QUICKFIT: Apriete quickfit hasta que el hombro se descargue con el panel. NO lo sobreapriete ni lo apriete poco.

DE_QUICKFIT: Ziehen Sie den Quickfit fest, bis die Schulter mit der Platte bündig ist. Bitte nicht zu fest oder zu schwach anziehen.

IT_MONTAGGIO RAPIDO: Stringere il montaggio rapido fino a quando la spalla è a filo con il pannello, non stringere troppo o troppo poco.

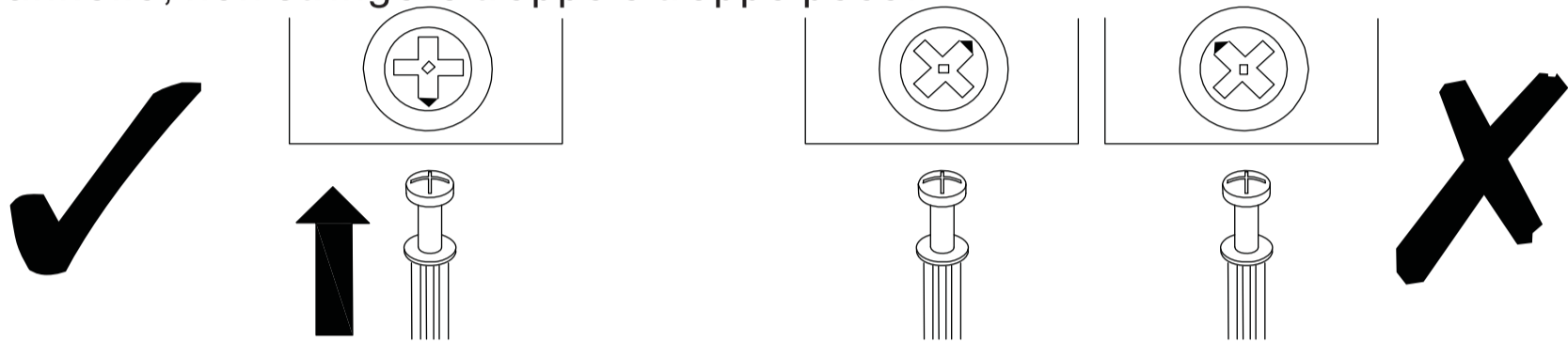

EN_CAM LOCK: When fitting cam lock, ensure starting position is correct before you insert connecting quickfit.

FR_SERRURE BATTEUSE: Avant d'insérer la serrure batteuse, veillez à la bonne orientation avant d'insérer le raccord rapide.

ES_CIERRE DE LA CÁMARA: Cuando instale el cierre de la cámara, asegúrese de que la posición de inicio es correcta antes de que inserte el quickfit conector.

DE_CAM-LOCK: Achten Sie bei der Montage des Cam-Locks auf die richtige Ausgangsposition, bevor Sie den Quickfit einsetzen.

IT_BLOCCAGGIO A CAMMA: Quando si monta il bloccaggio a camma, assicurarsi che la posizione iniziale sia corretta prima di inserire il montaggio rapido di collegamento.

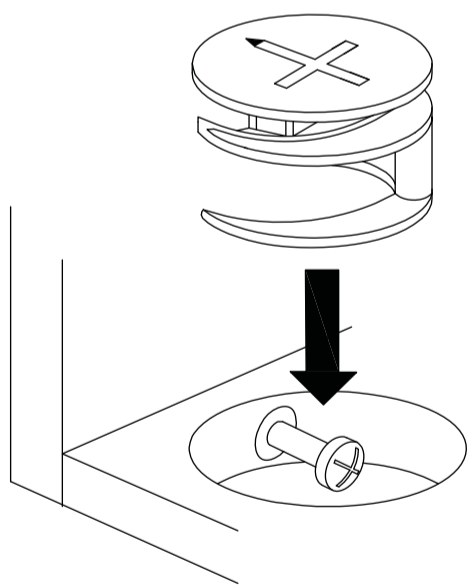

EN_Quickfit head should be in the centre of the cam lock when the two panels are joined.

Cam lock should be inserted before quickfit.

FR_Lorsque les deux panneaux sont assemblés, la tête du raccord rapide doit reposer au centre de la serrure batteuse. Il faut insérer la serrure batteuse avant le raccord rapide.

ES_El cabezal del quickfit debe estar en el centro del cierre de la cámara cuando se unan los dos paneles.

Se debe insertar el cierre de la cámara antes que el quickfit.

DE_Der Quickfit-Kopf sollte sich in der Mitte des Cam-Locks befinden, wenn die beiden Platten zusammengefügt sind. Der Cam-Lock sollte vor dem Quickfit eingesetzt werden.

IT_La testa del montaggio rapido deve trovarsi al centro del bloccaggio a camma quando i due pannelli sono uniti.

Il Bloccaggio a Camma deve essere inserito prima del montaggio rapido.

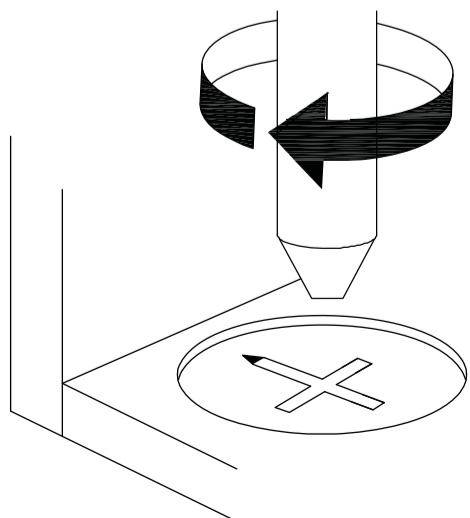

EN_Turn cam lock clockwise to tighten.

FR_Faites tourner la serrure batteuse dans le sens des aiguilles d'une montre pour la resserrer.

ES_Gire el cierre de la cámara en sentido horario para apretarlo.





DE_Drehen Sie den Cam-Lock im Uhrzeigersinn, um ihn festzuziehen.

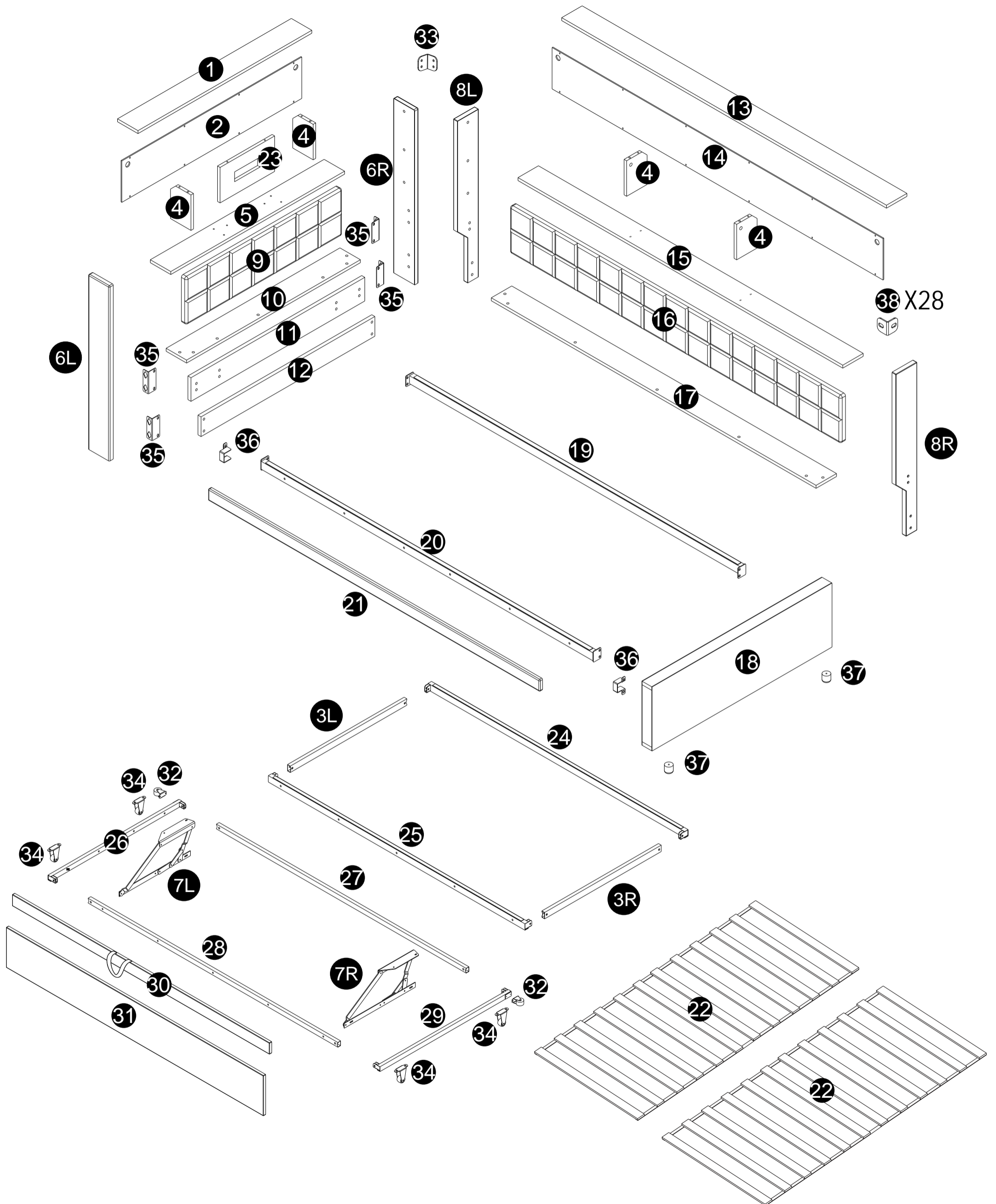

IT_Ruotare il bloccaggio a camma in senso orario per stringere.

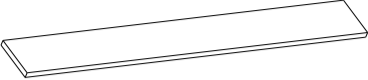



Stückliste

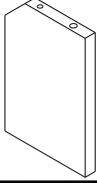

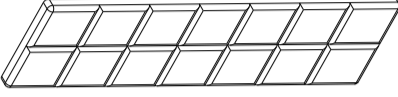
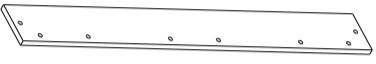
N616P381027

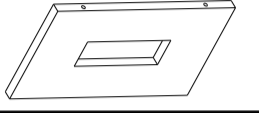
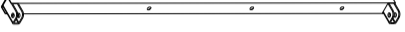

1		X1
2		X1
3L		X1
3R		X1

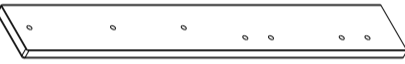
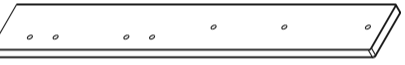
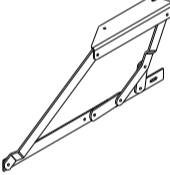
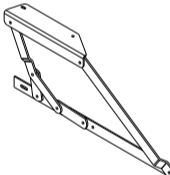

4		X4
5		X1
9		X1
10		X1

11		X1
12		X1
18		X1
23		X1
26		X1
29		X1

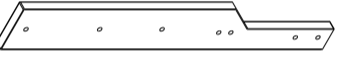

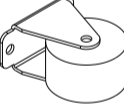
N616P381028

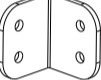
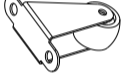
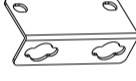
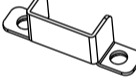
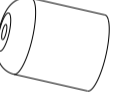



6L		X1
6R		X1
7L		X1
7R		X1

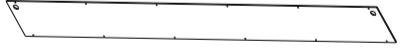

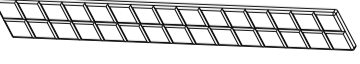
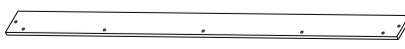

8L		X1
8R		X1
22		X2
32		X2

33		X1
34		X4
35		X4
36		X2
37		X2
38		X28

N616P381029

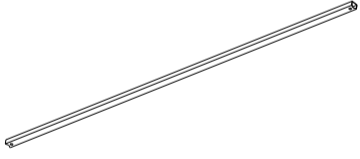
13		X1
14		X1
15		X1
16		X1
17		X1

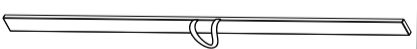
19		X1
20		X1
21		X1
24		X1
25		X1



27		X1
28		X1
30		X1
31		X1

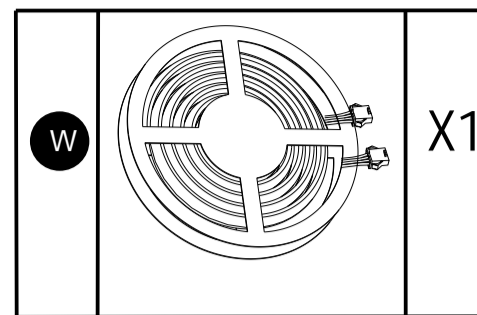
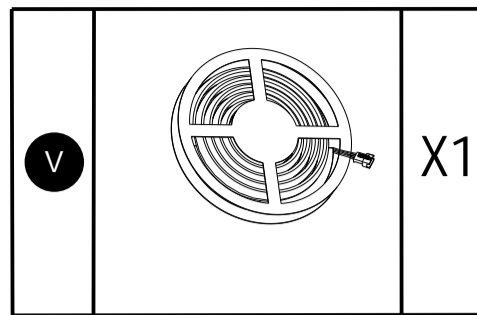

Hardware List-Hardware-Liste-Liste du matériel

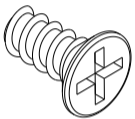

N616P381027

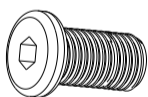
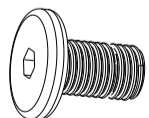
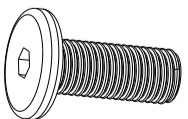

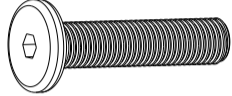
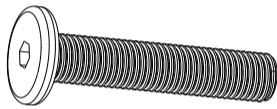

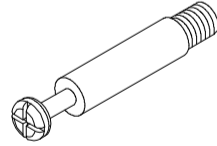
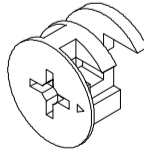
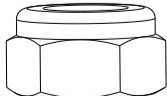
N616P381028

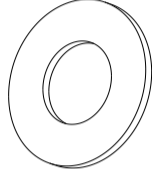
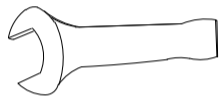
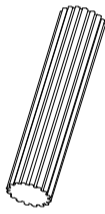

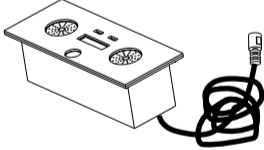
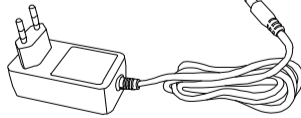
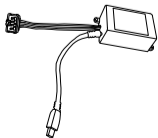
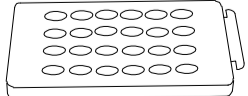
A		X1
B	 M4x10mm	X4
C	 4.0x15mm	X6
D	 5.0x40mm	X30
E	 M6x16mm	X10
F	 M8x12mm	X28
G	 M8x20mm	X64

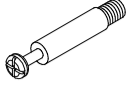
H	 M8x30mm	X8
J	 M8x40mm	X8
K	 M6x30mm	X7
L	 M6x35mm	X11
M	 X4	X4
N	 X4	X4
P	 M8	X8

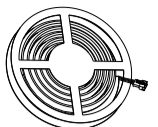
Q	 M8	X16
R		X1
S	 Φ6x30MM	X6
T		X1
U		X1
X		X1
Y		X1
Z		X1

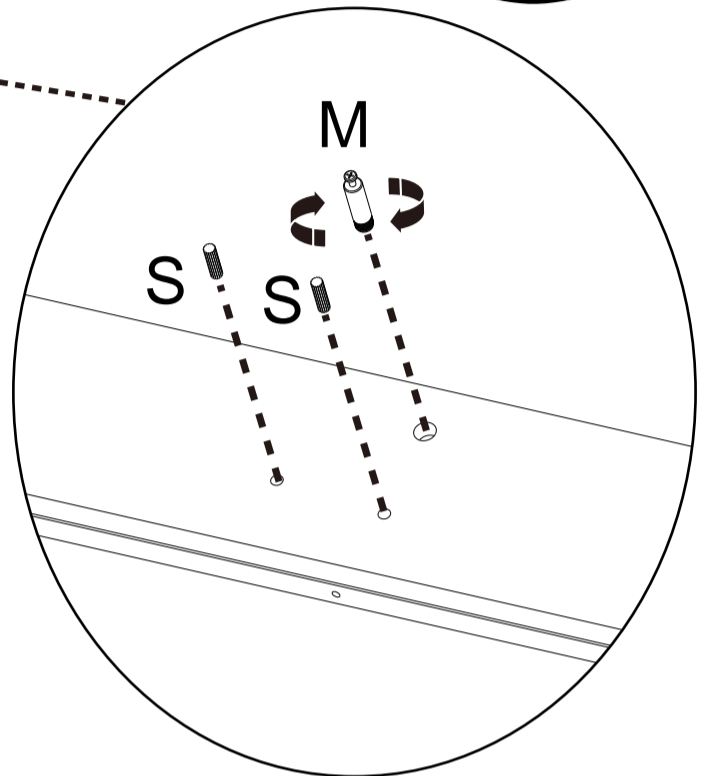
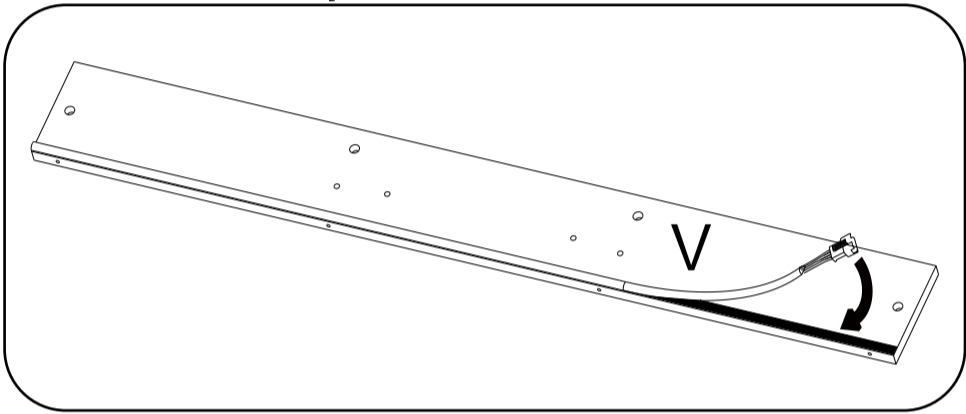
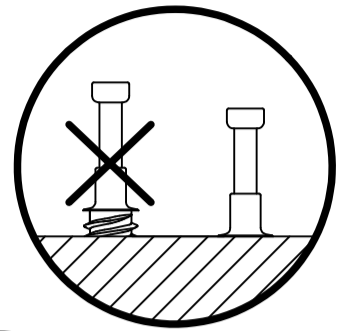
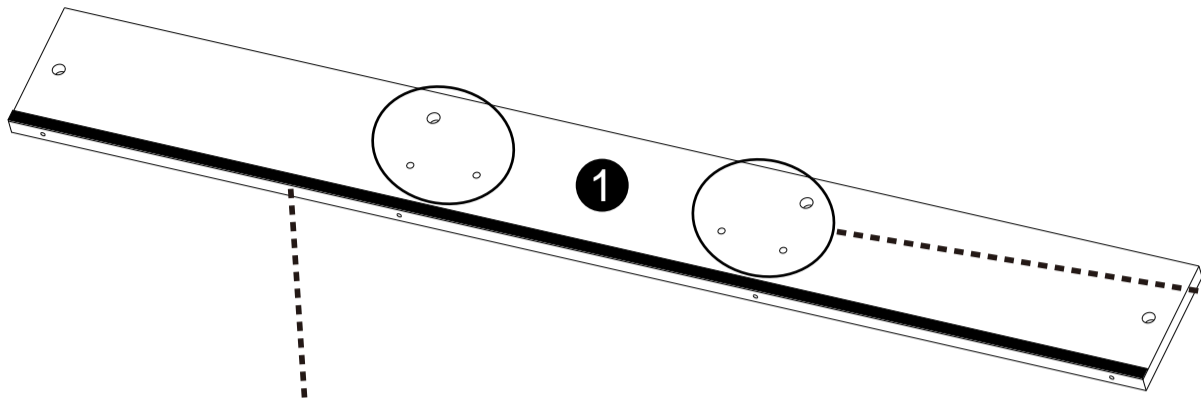
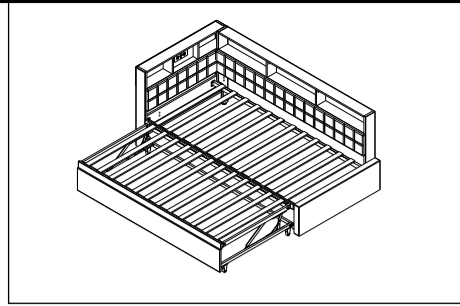
1L	M x 2	S x 4	V x 1
			

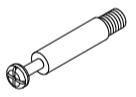

1R	M x 2	S x 4	V x 1
			

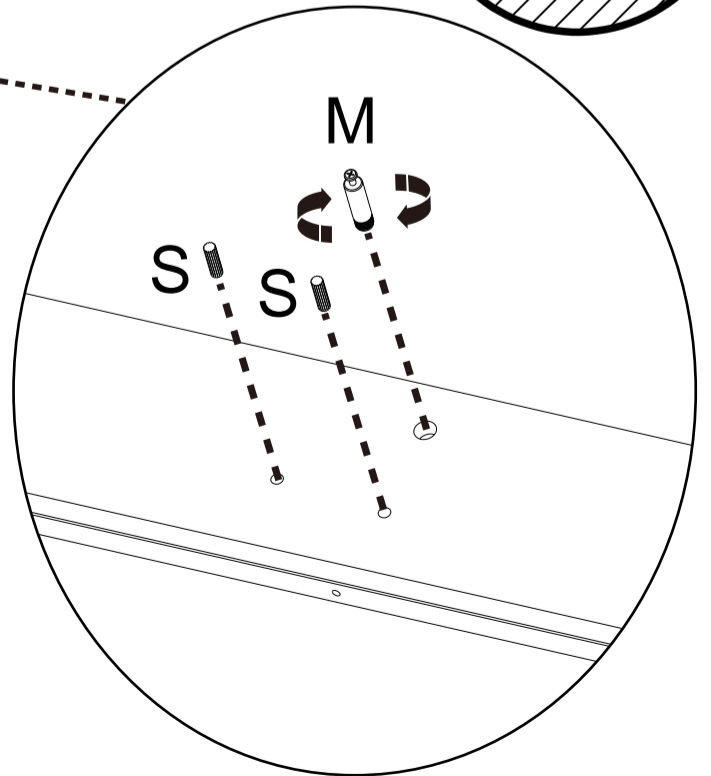
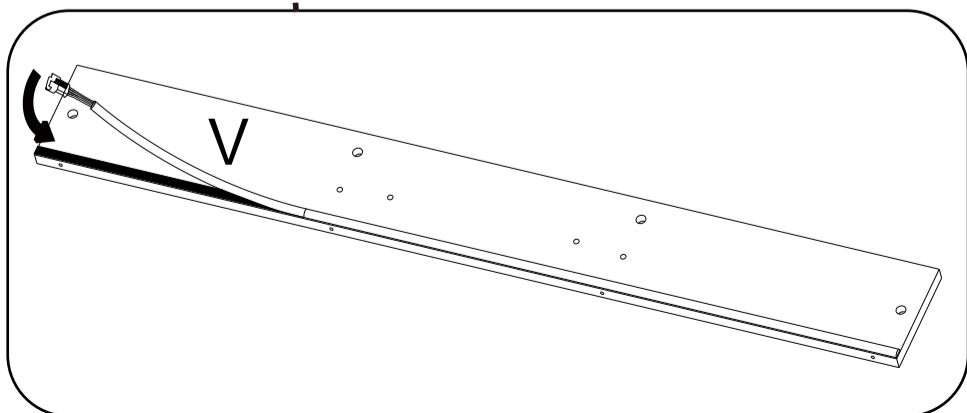
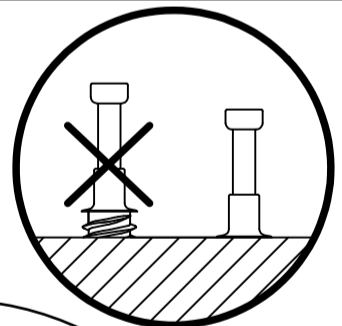
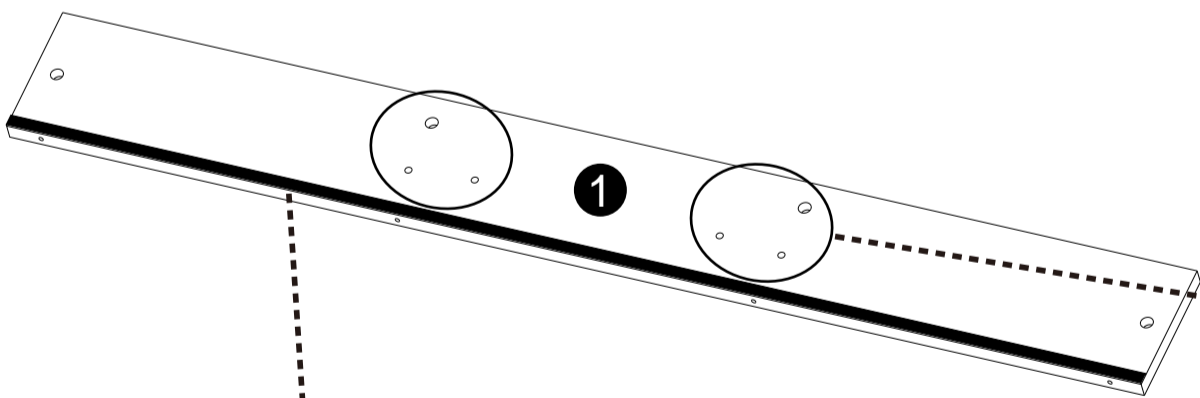
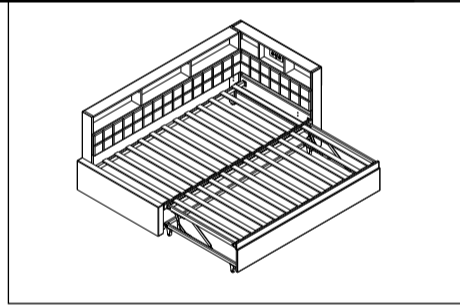

2 U x 1

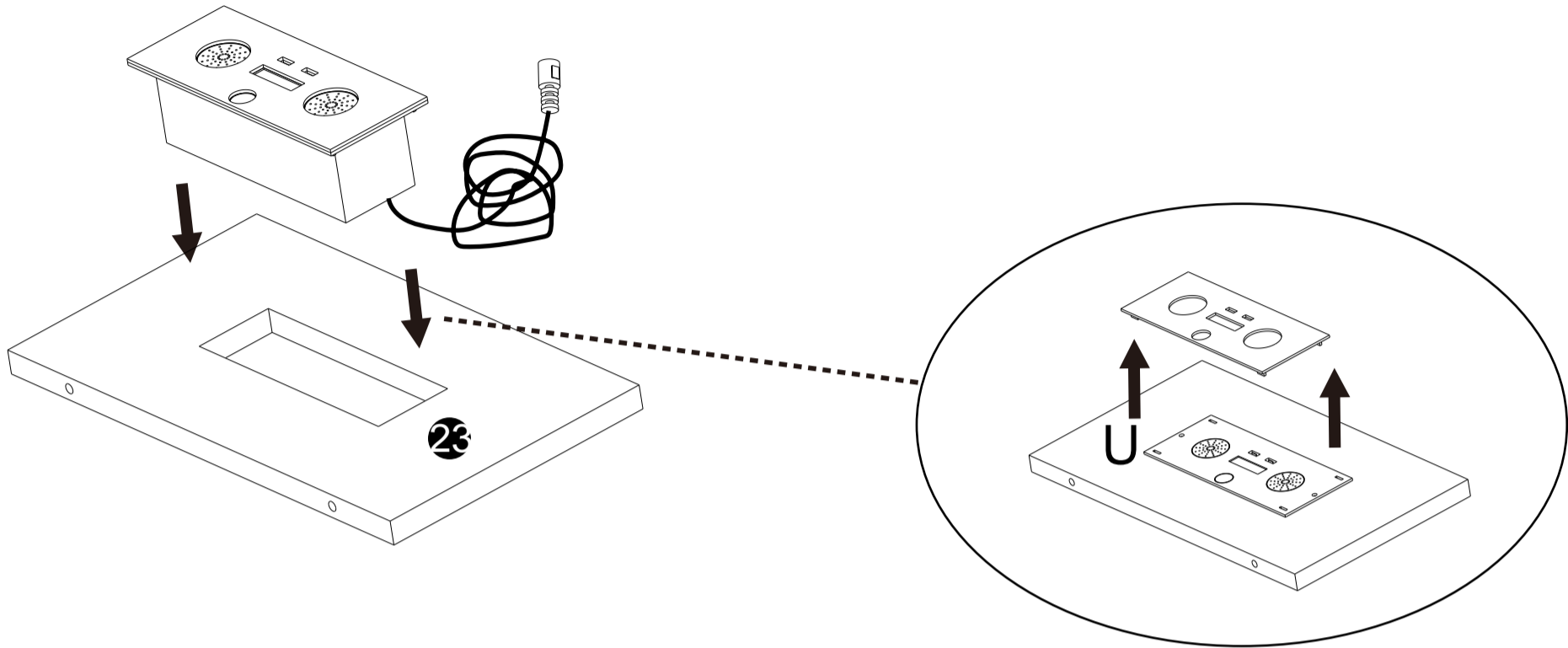

3 C x 2
4.0x15mm

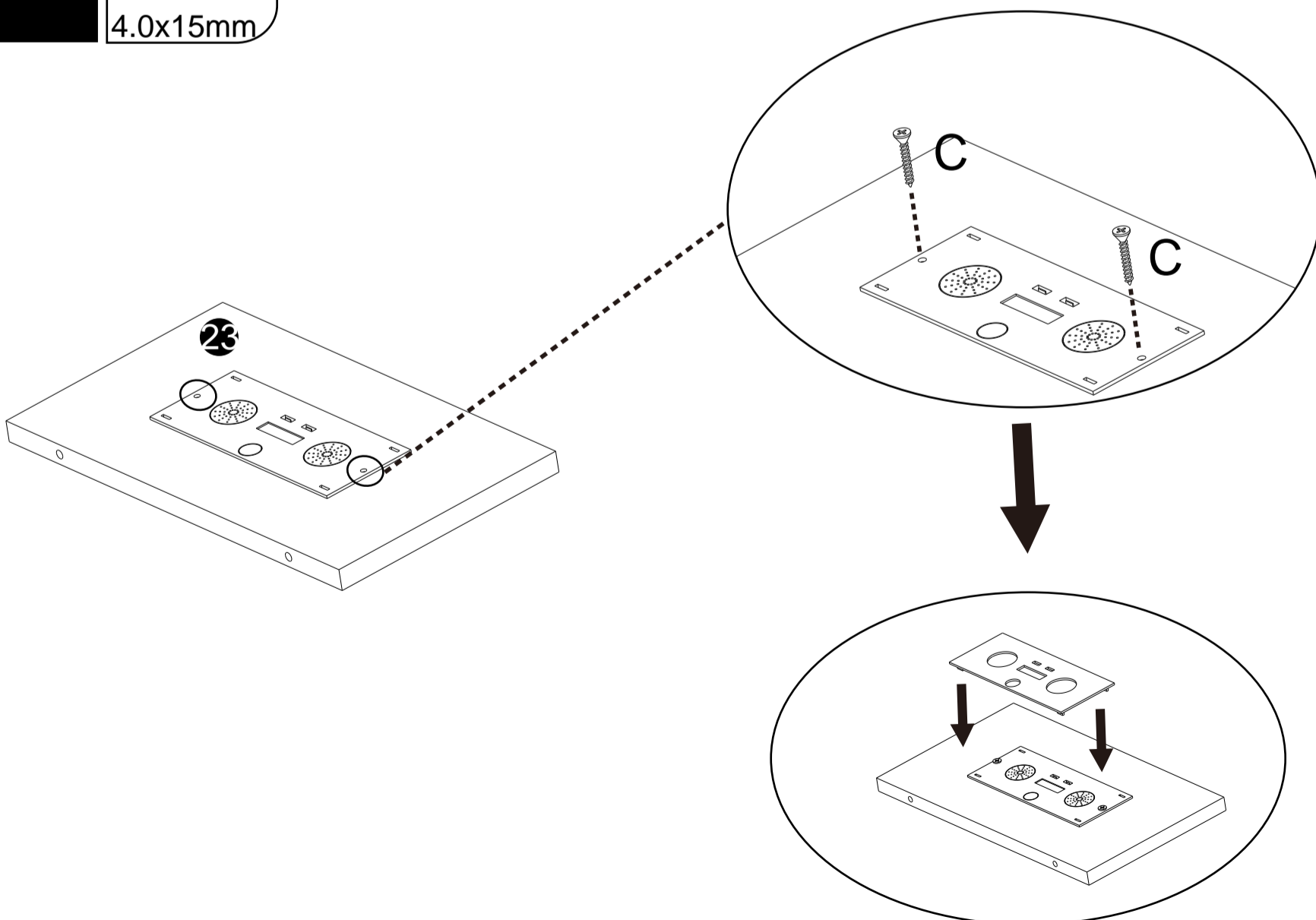

4

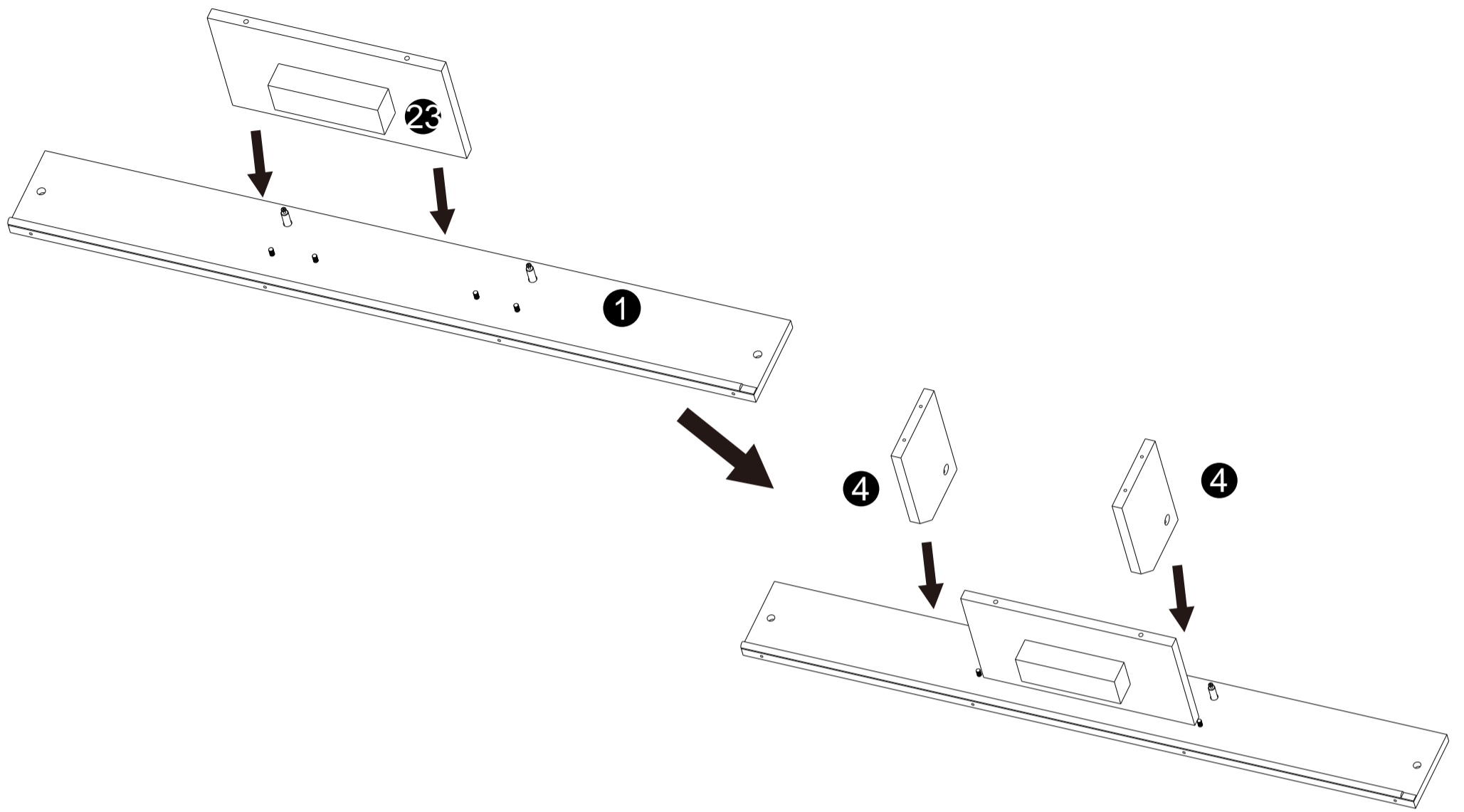

5

N x 2

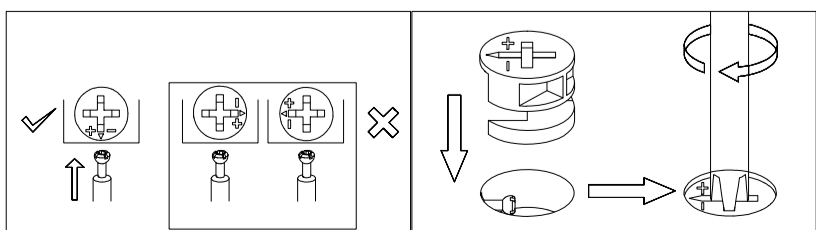
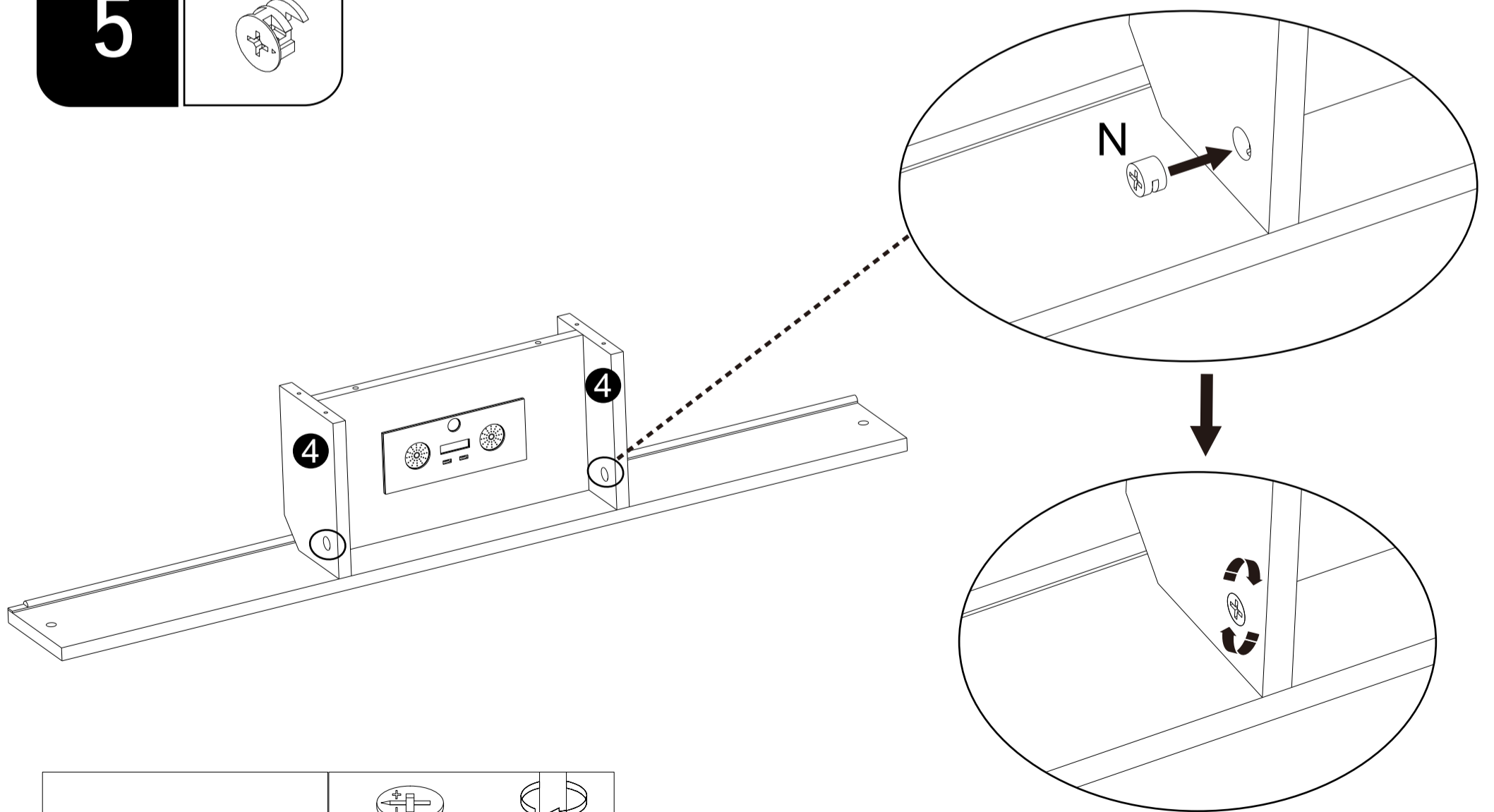

6

D x 6



5.0x40mm

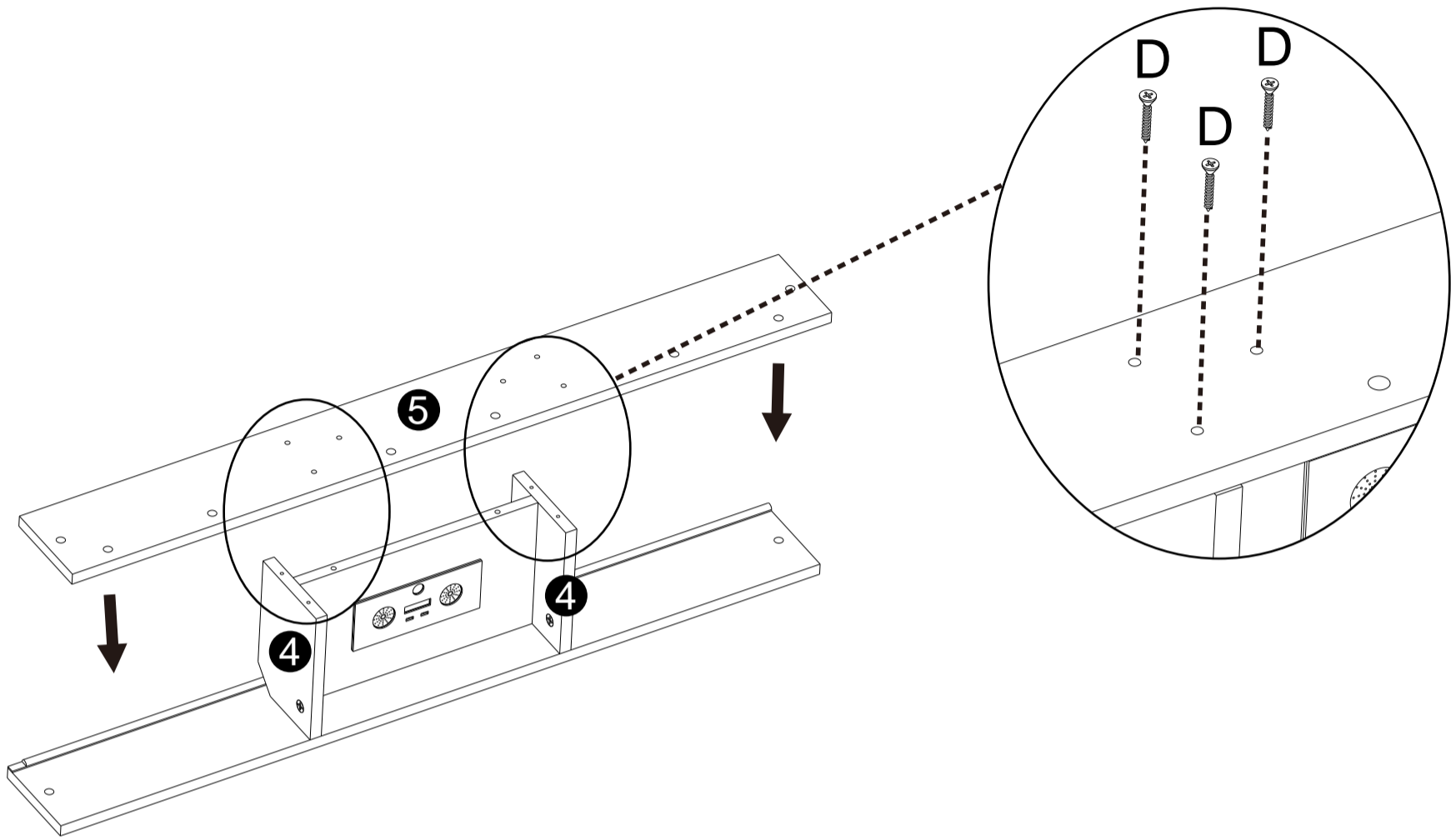

7

A x 1

F x 4

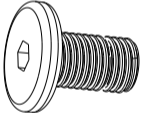

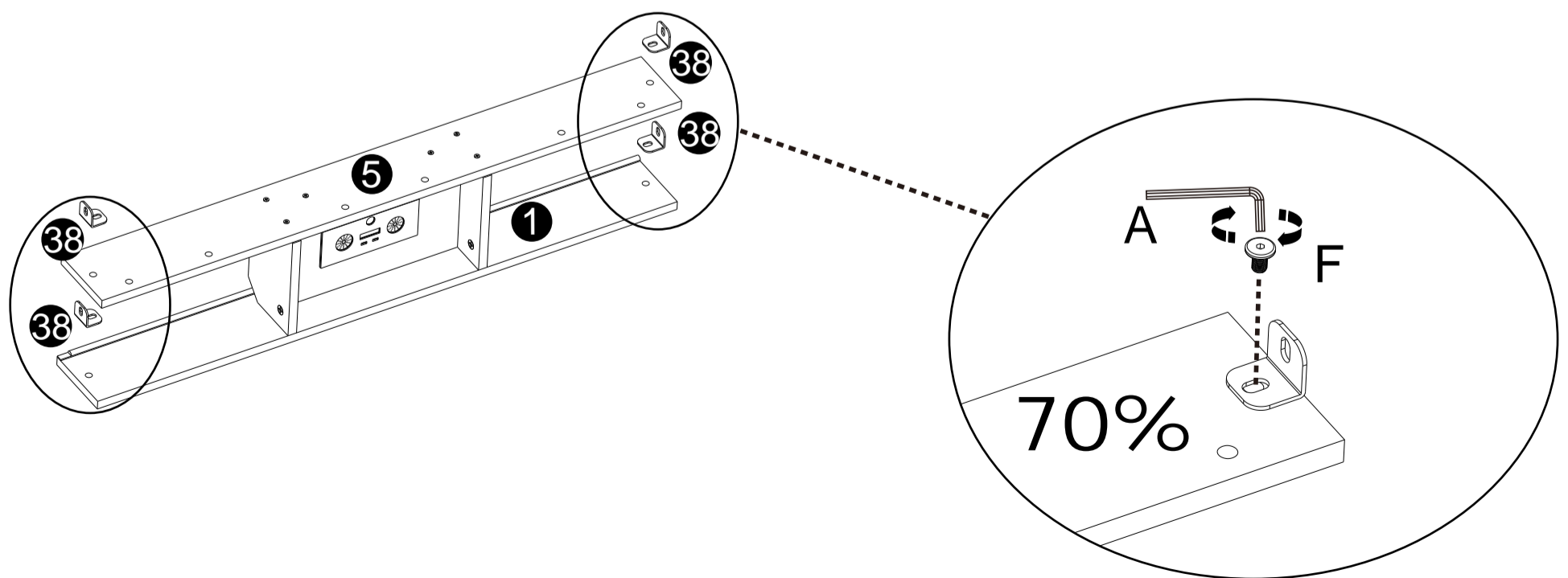

M8 x 12mm

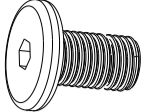

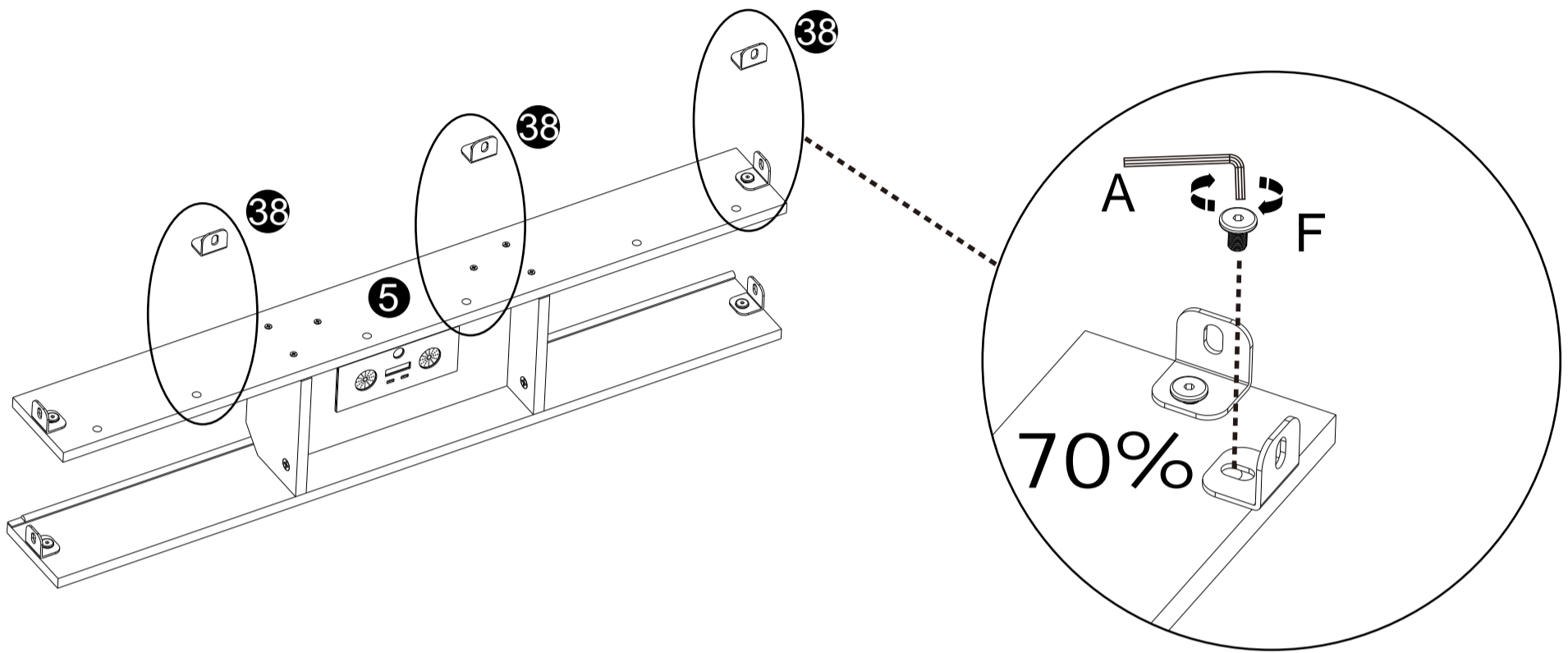
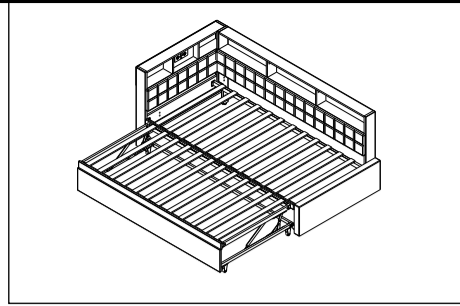
8L	A x 1	F x 3
		 M8 x 12mm

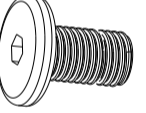

8R	A x 1	F x 3
		 M8 x 12mm

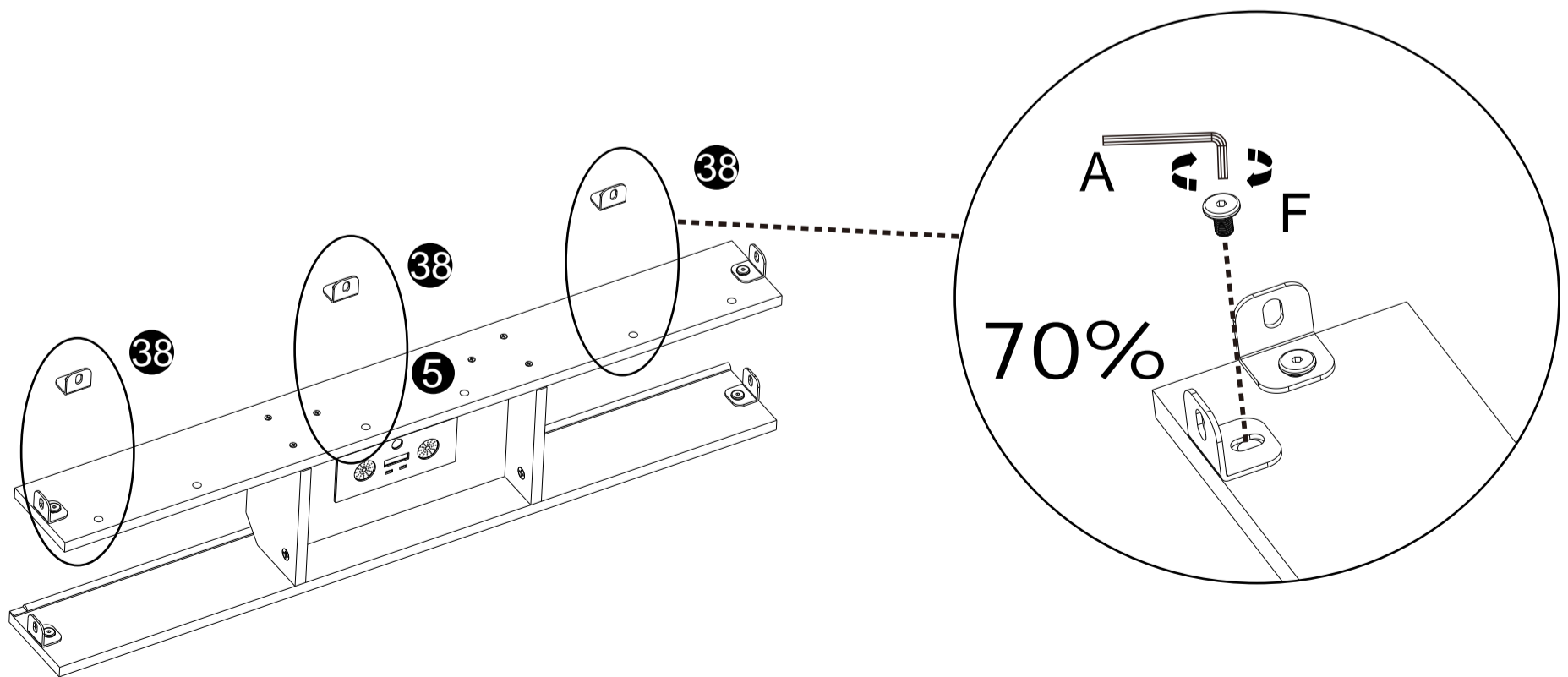
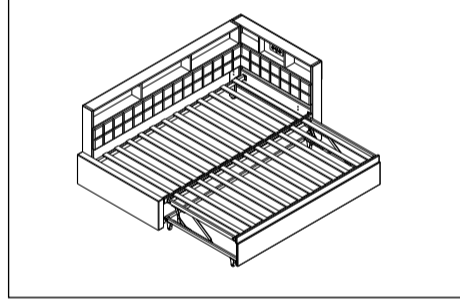

9L D x 8
5.0x40mm

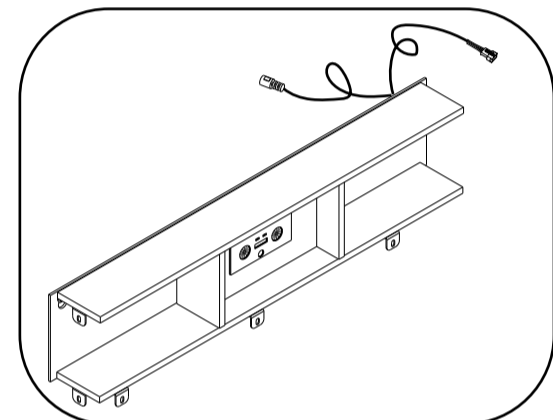
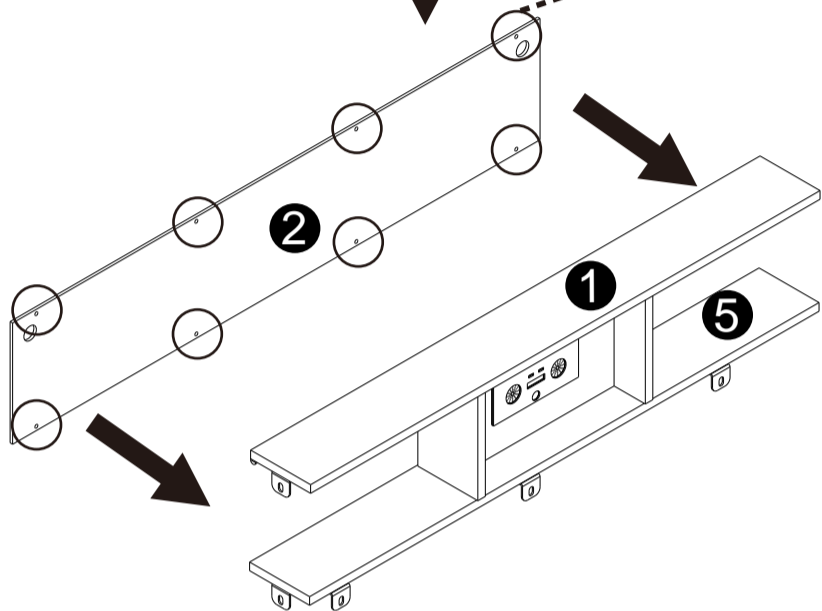
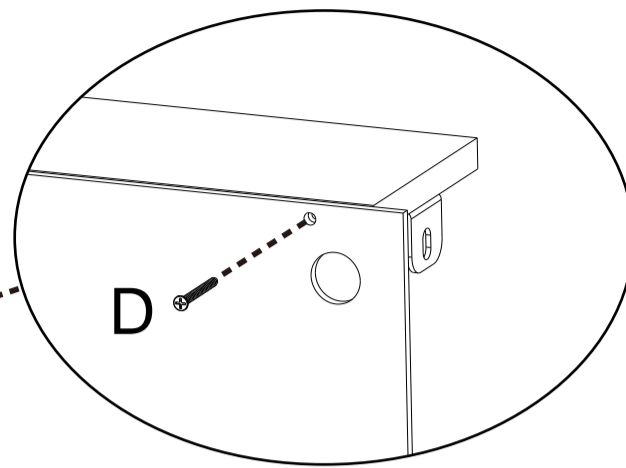
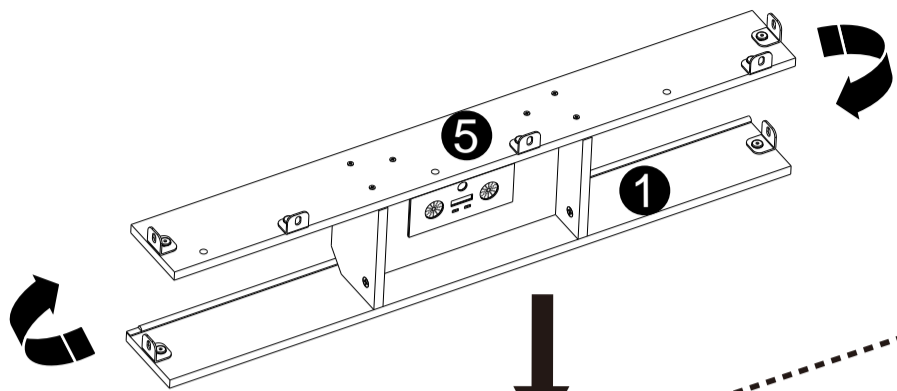
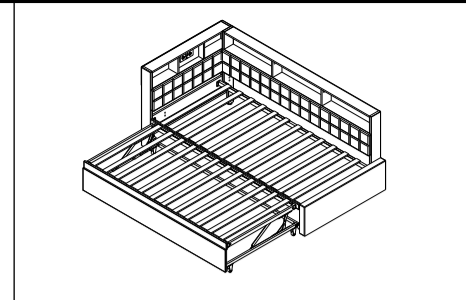
9R D x 8
5.0x40mm



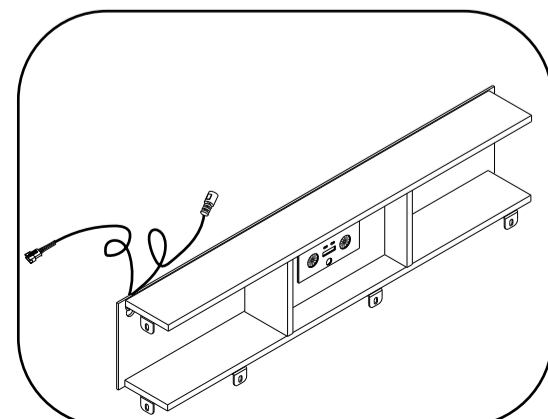
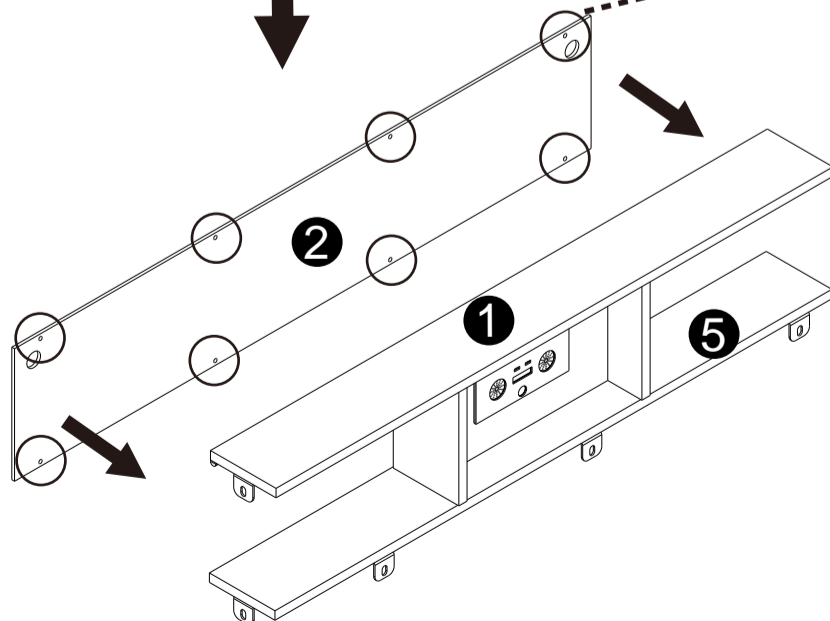
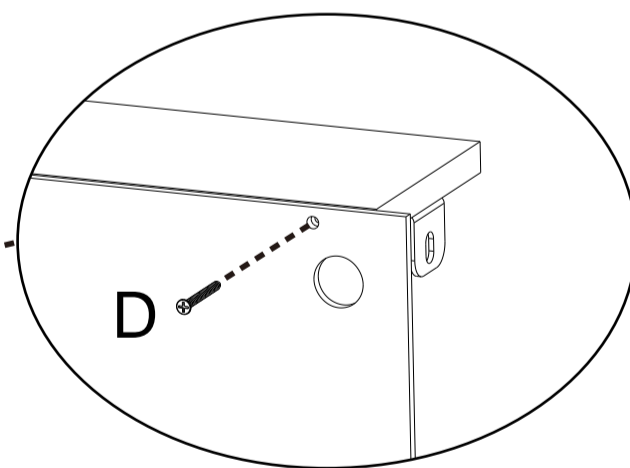
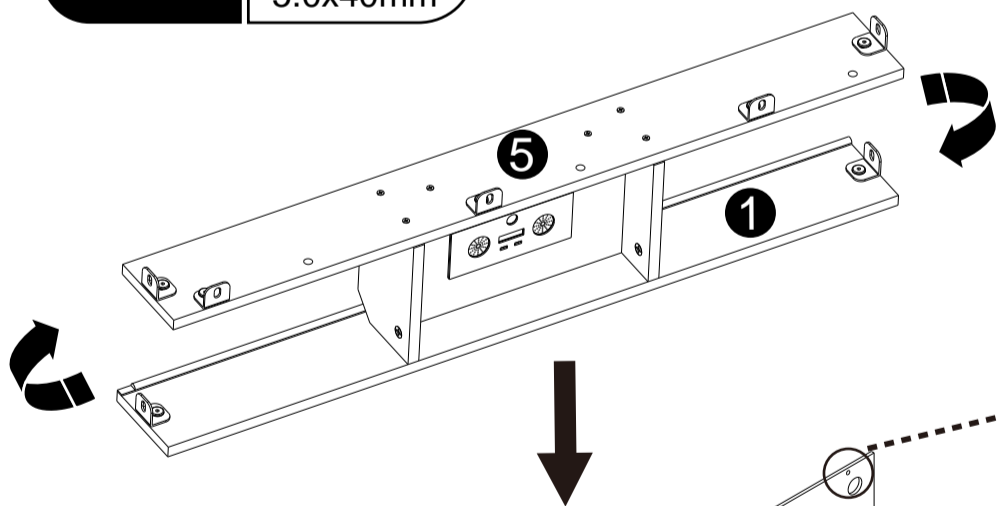
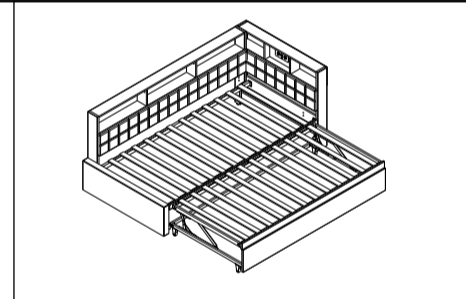

10

A x 1

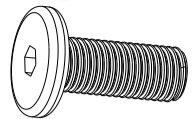

G x 12



M8 x 20mm

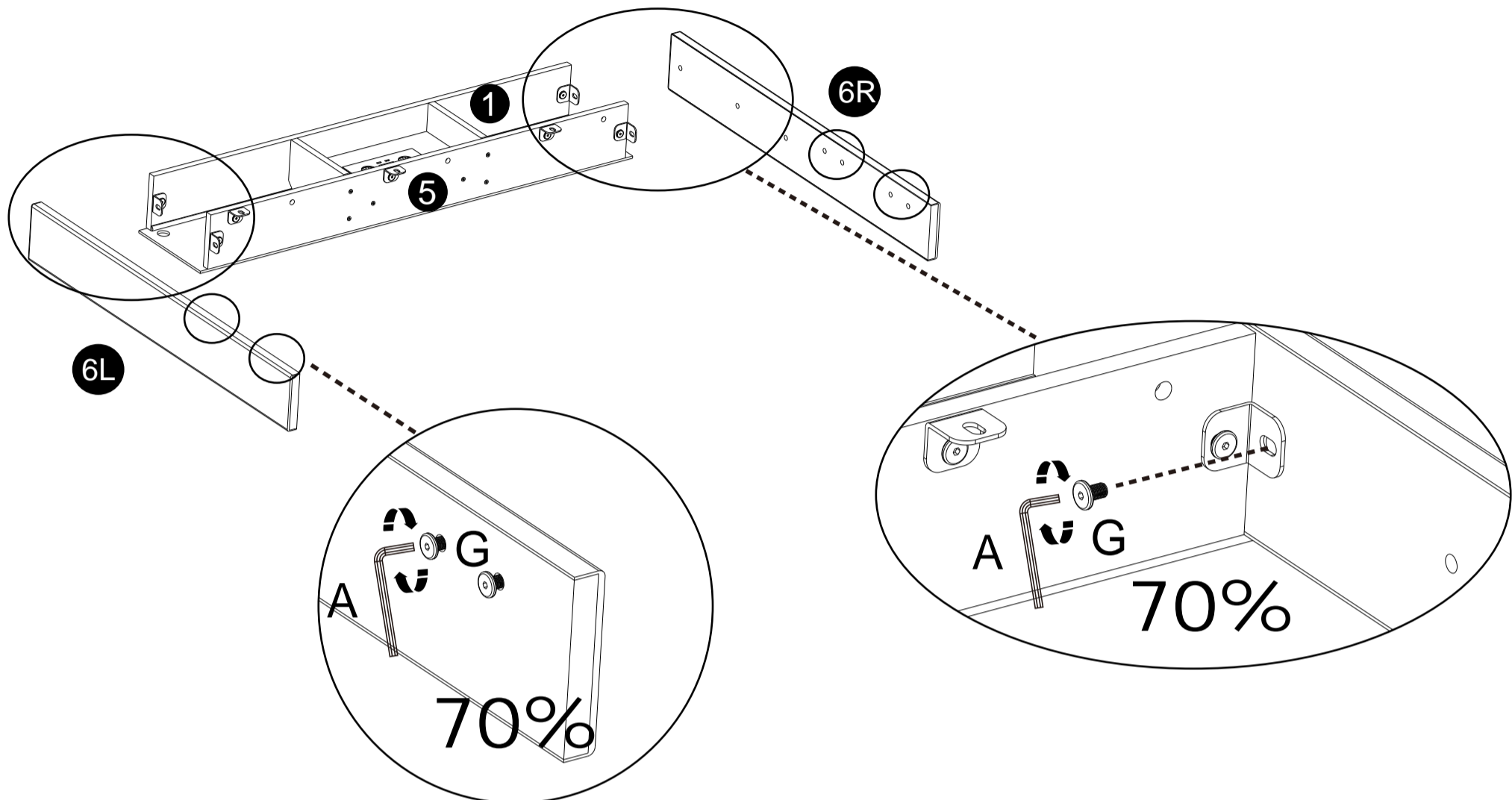

11

A x 1



G x 8

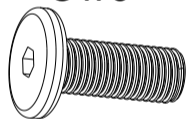

M8 x 20mm

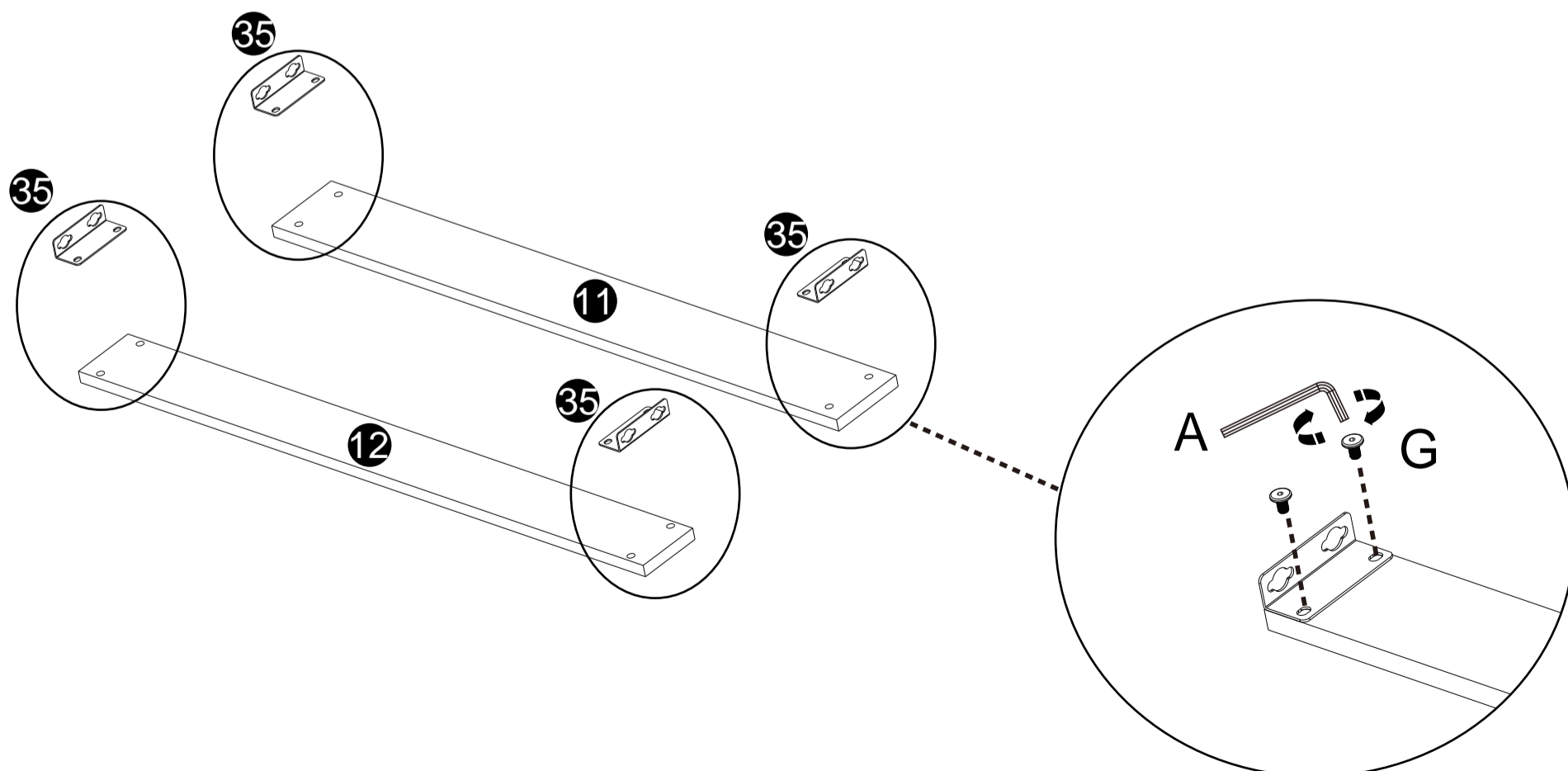

12L

A x 1



F x 5

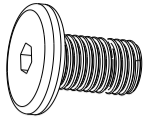

M8 x 12mm

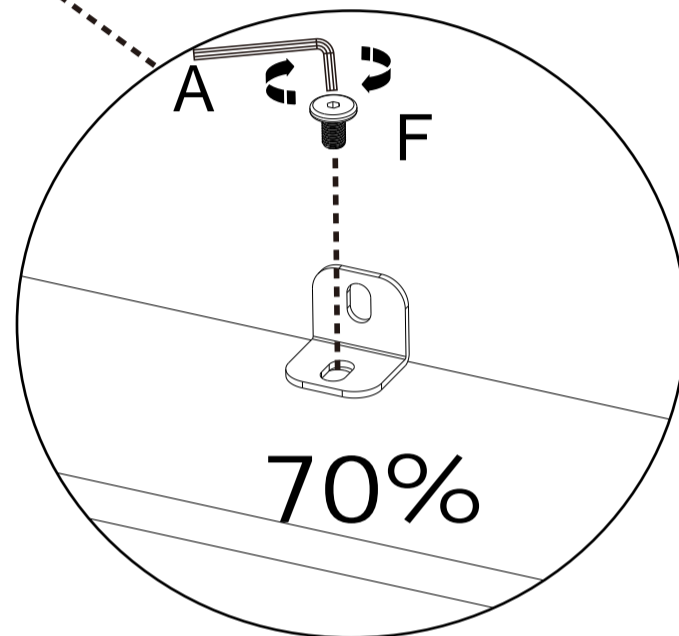
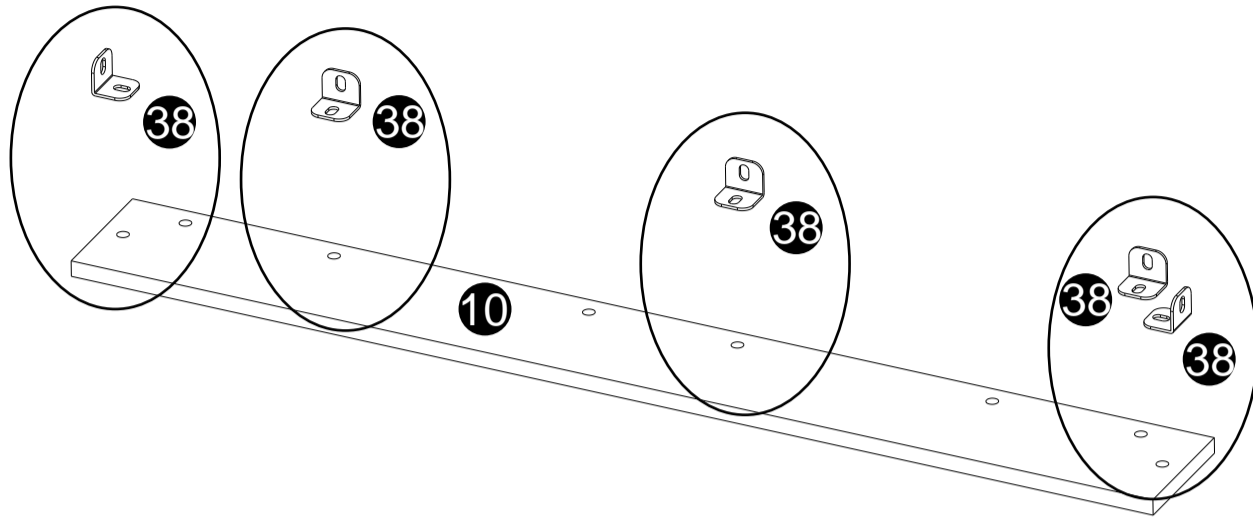
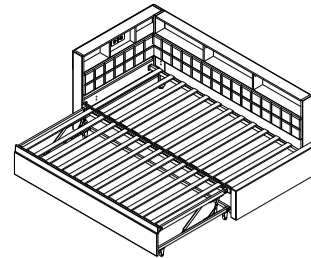

12R

A x 1



F x 5

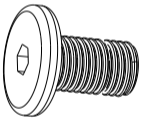

M8 x 12mm

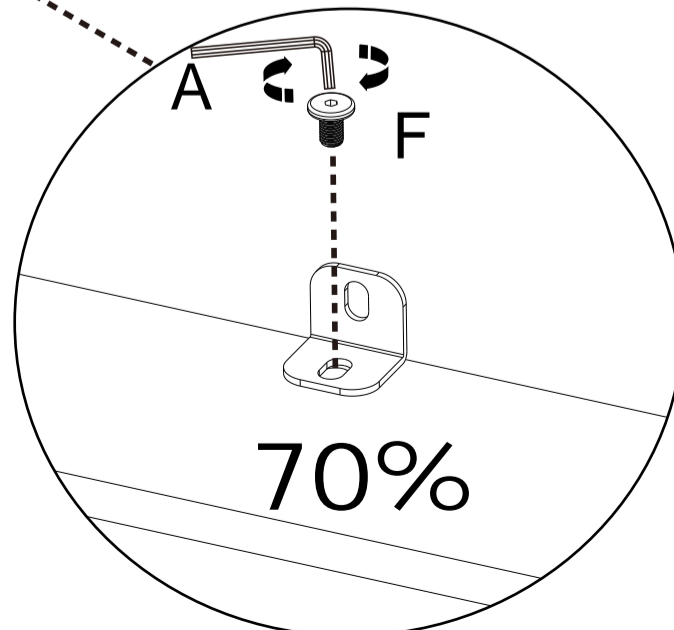
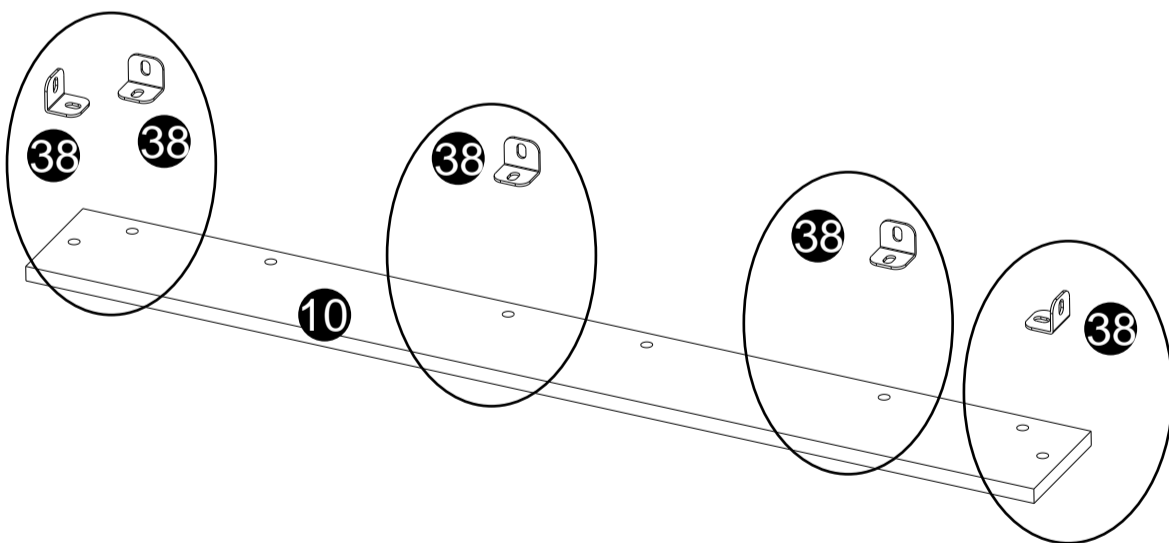
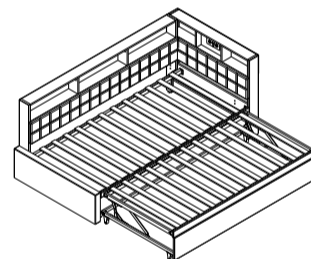

13

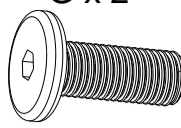
A x 1	G x 2
	
	M8 x 20mm

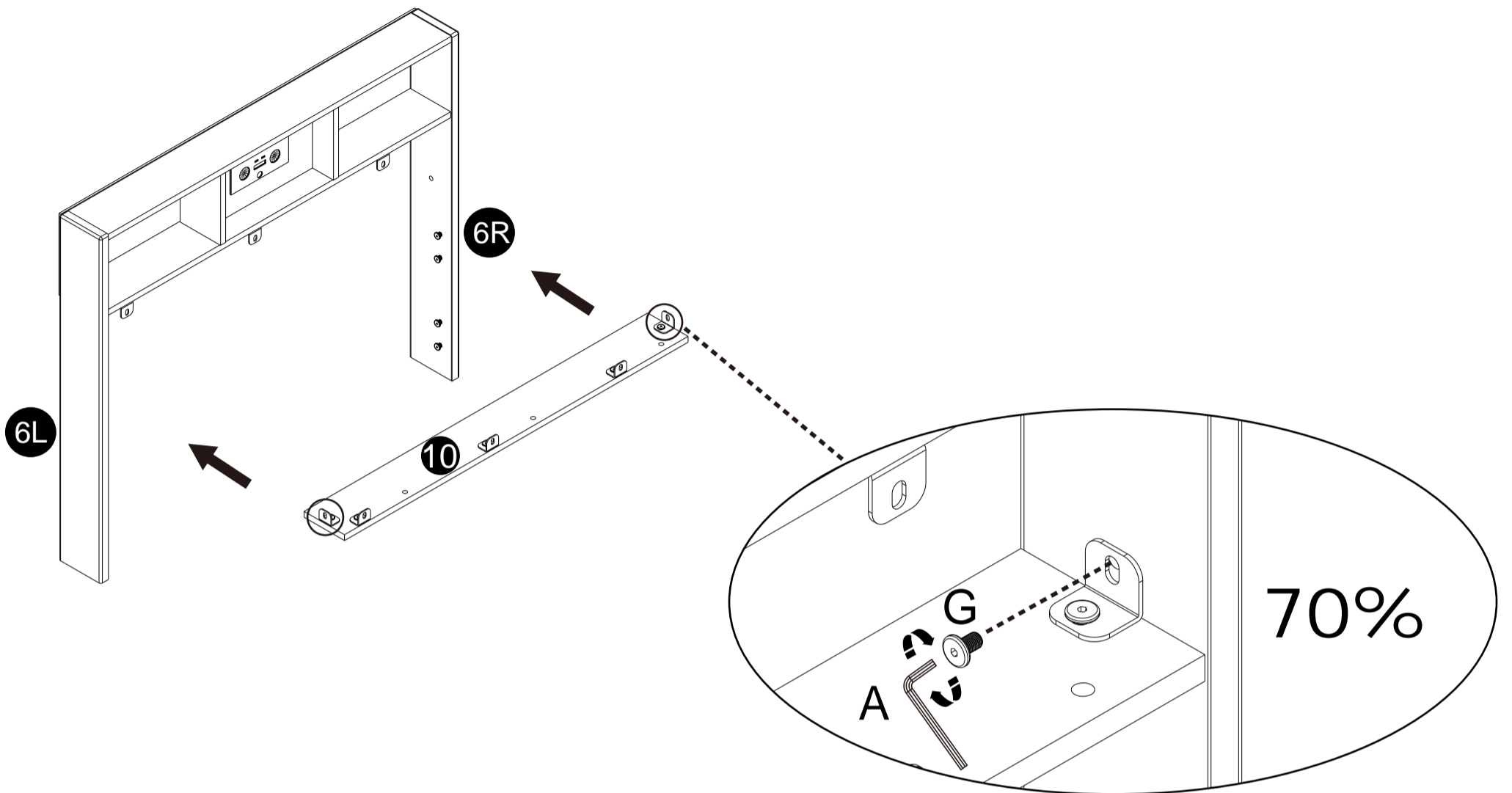

14

A x 1

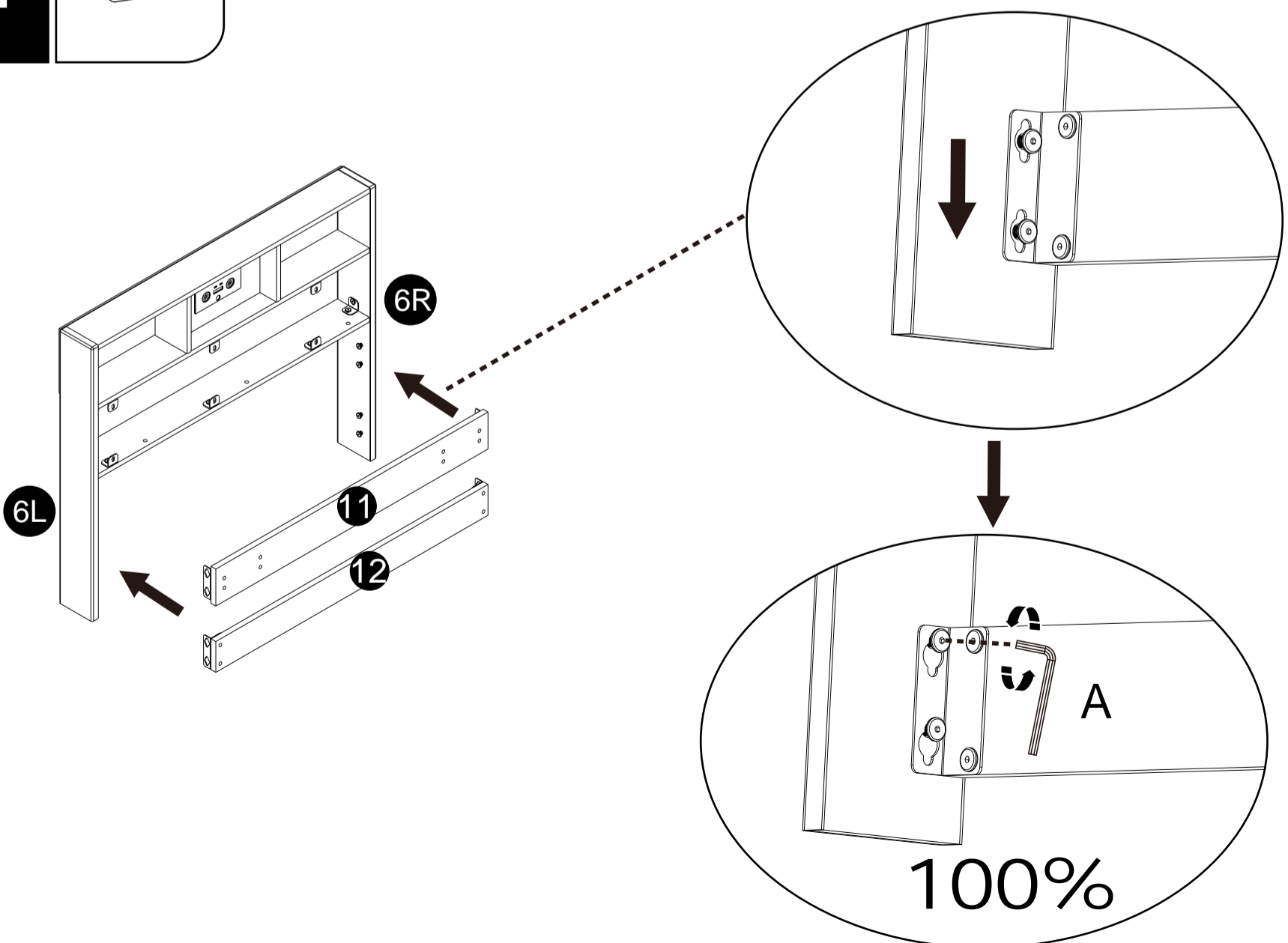

15L

A x 1



G x 6

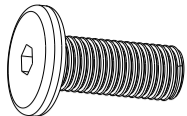

M8 x 20mm

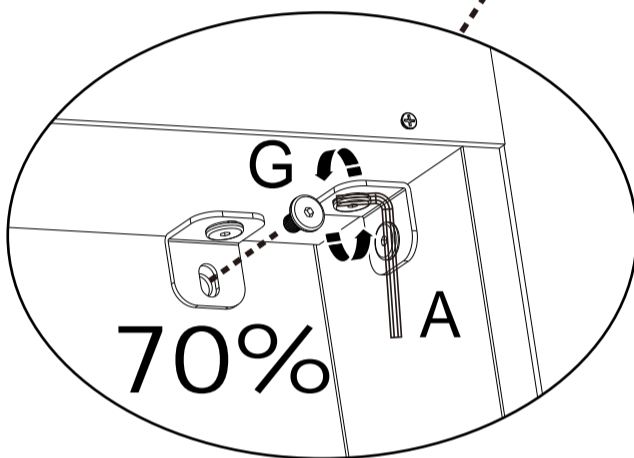
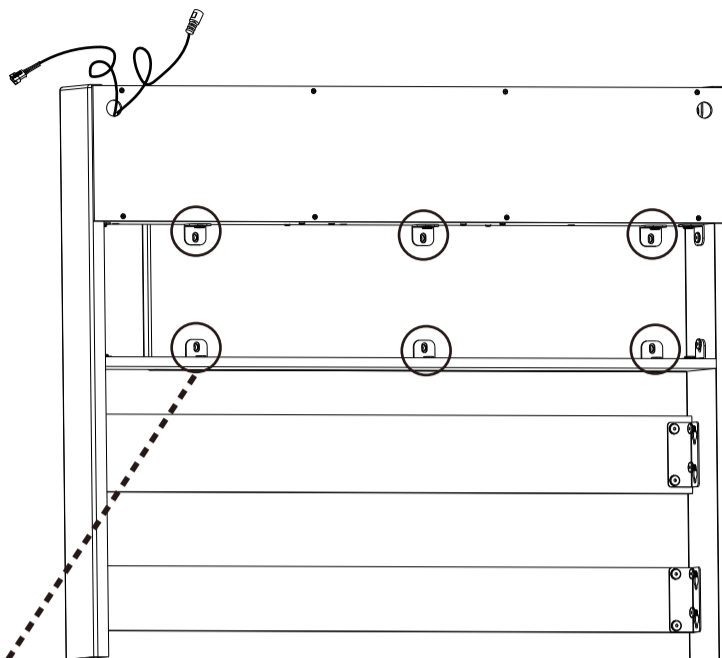
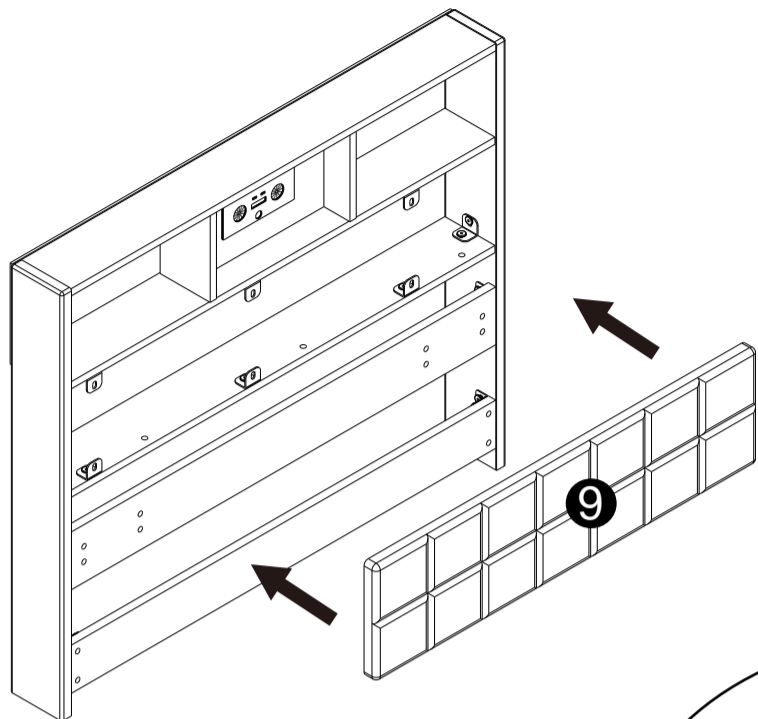
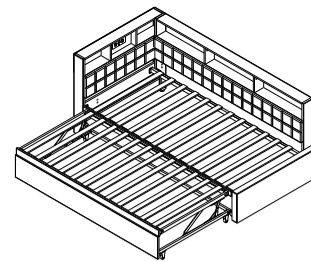

15R

A x 1



G x 6

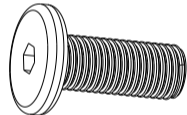

M8 x 20mm

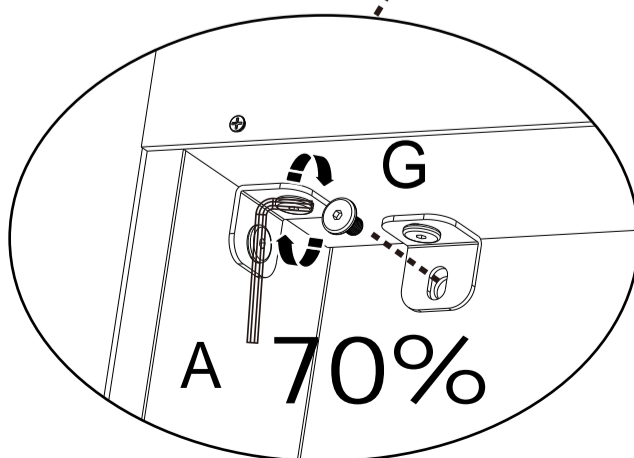
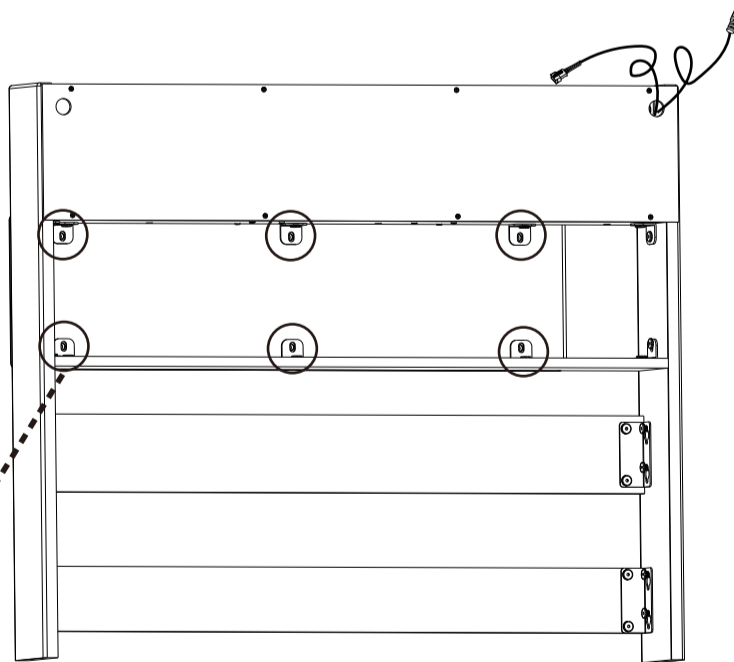
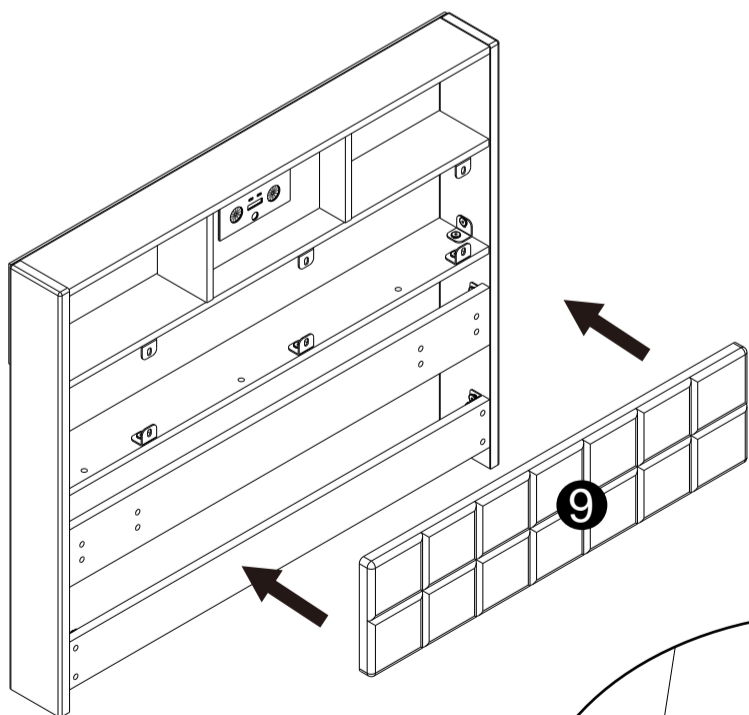
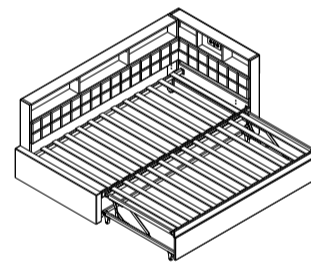

16L Ax1

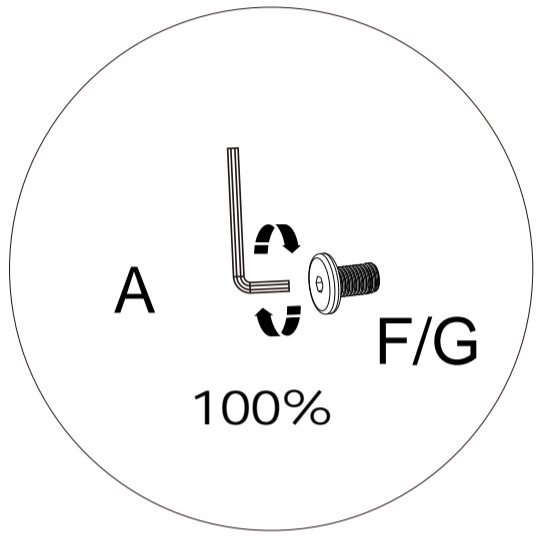
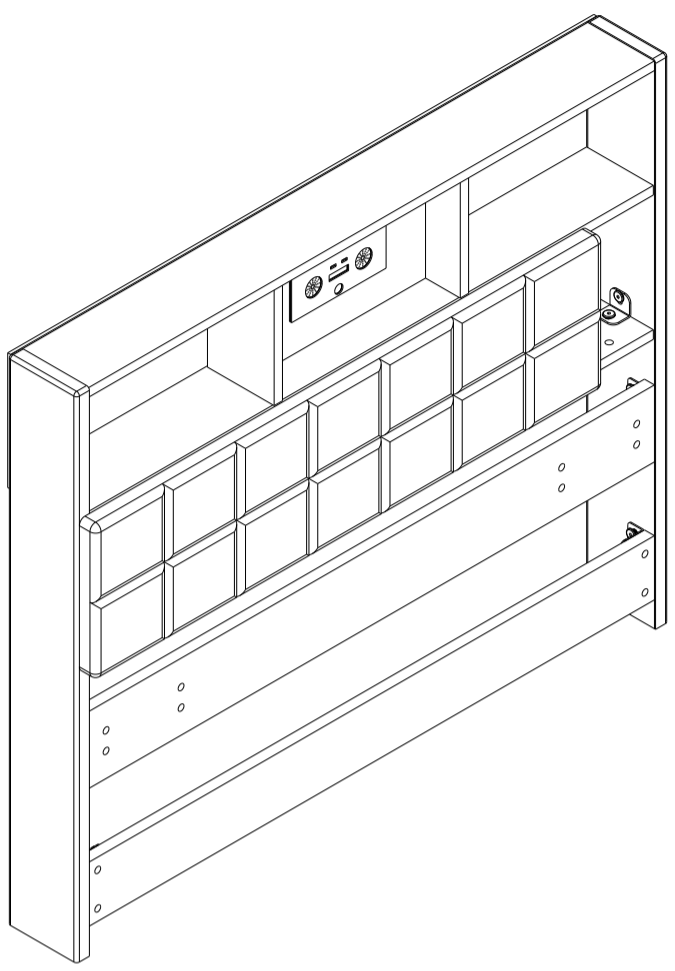
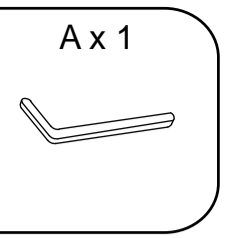

16R Ax1

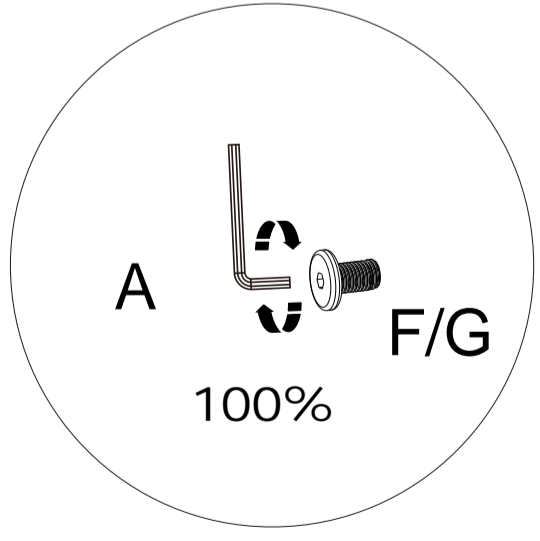
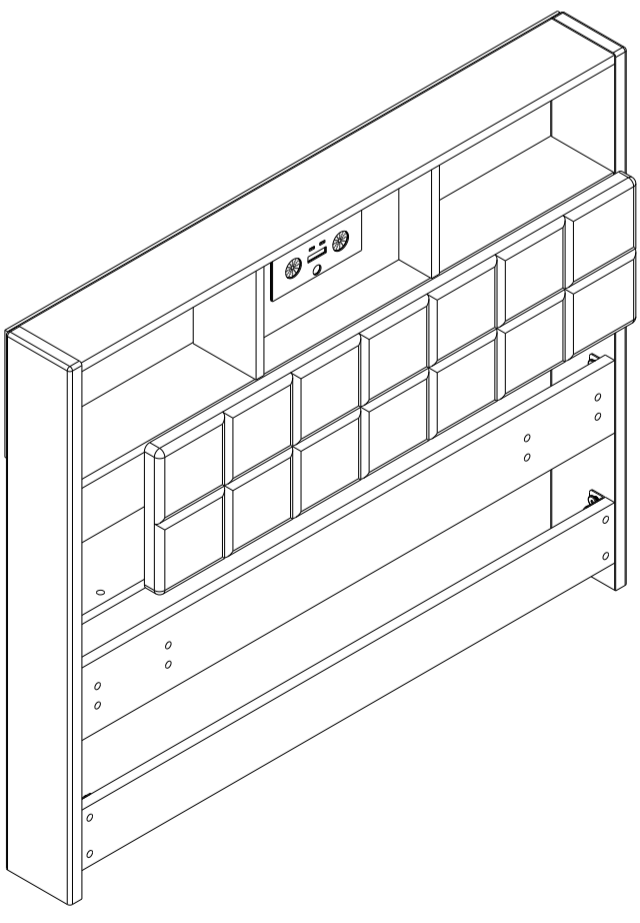
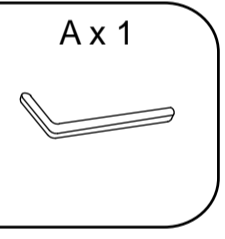

17

M x 2

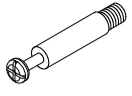

S x 2



W x 1

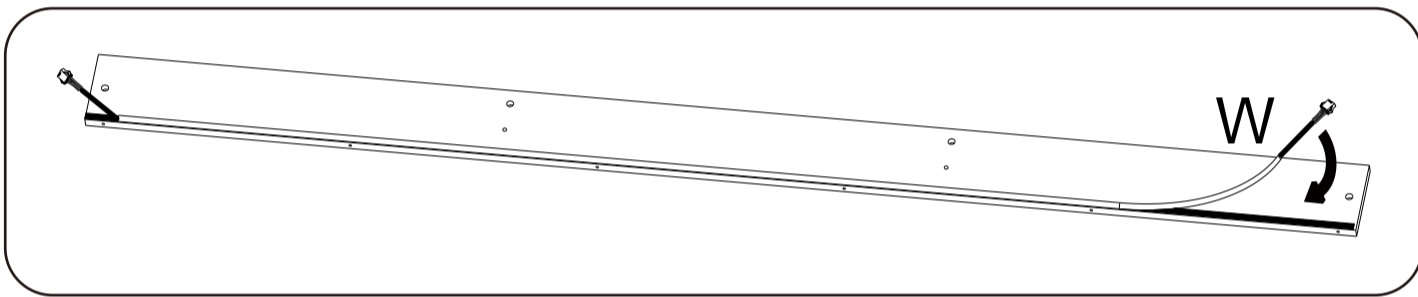
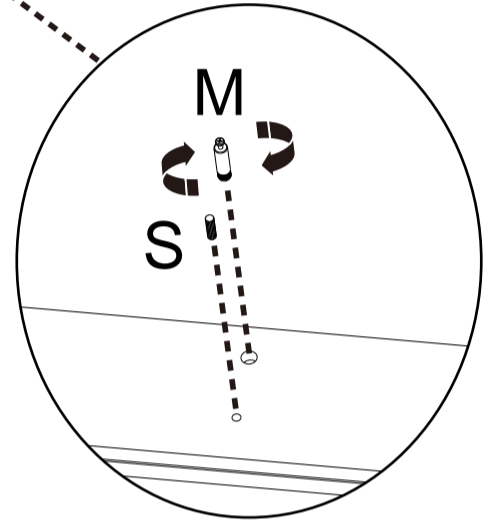
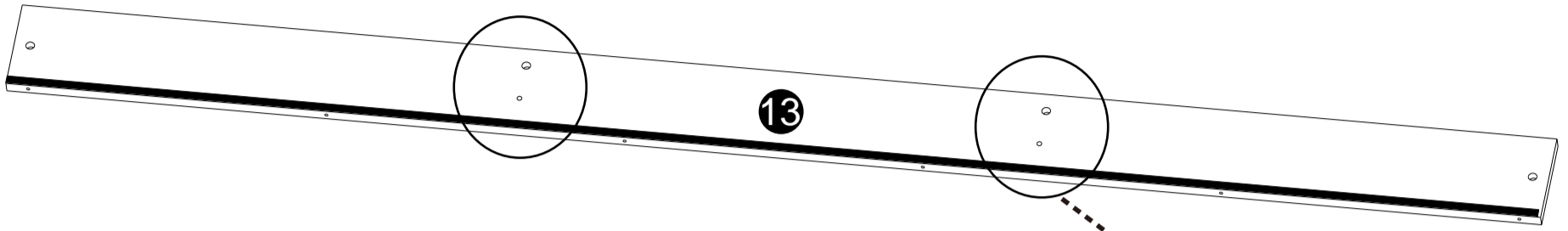
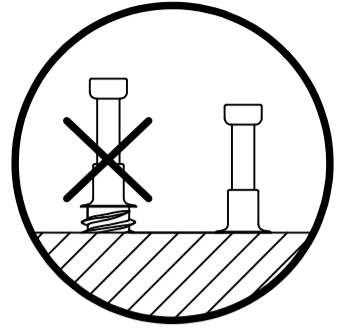
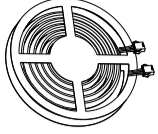

18

N x 2

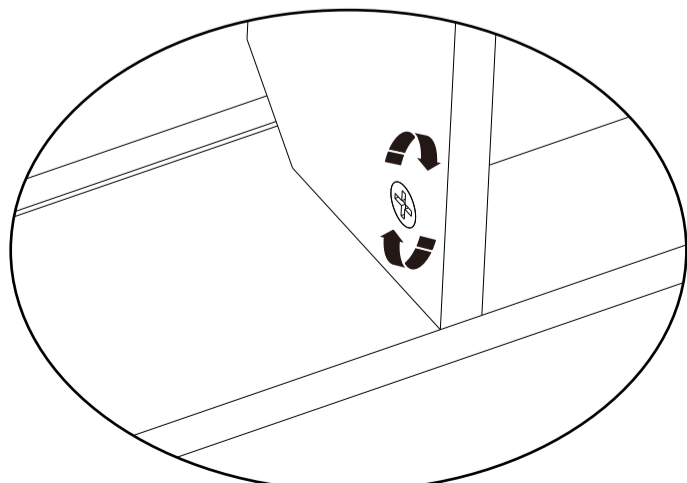
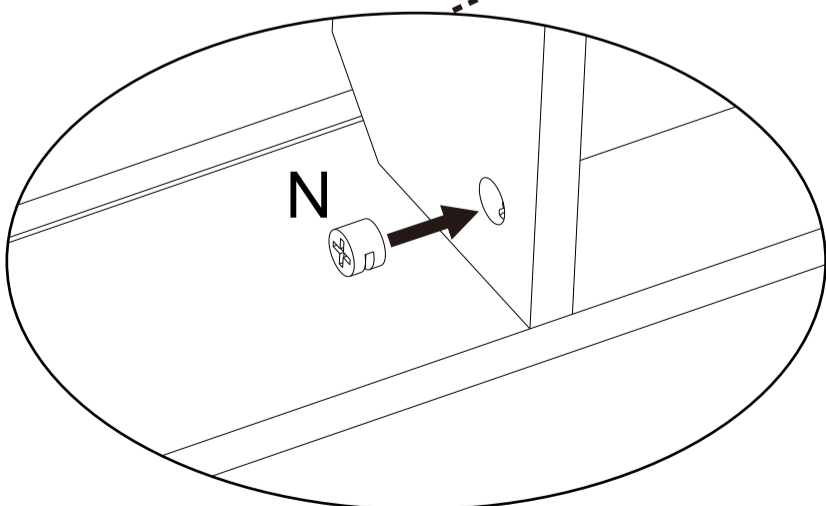
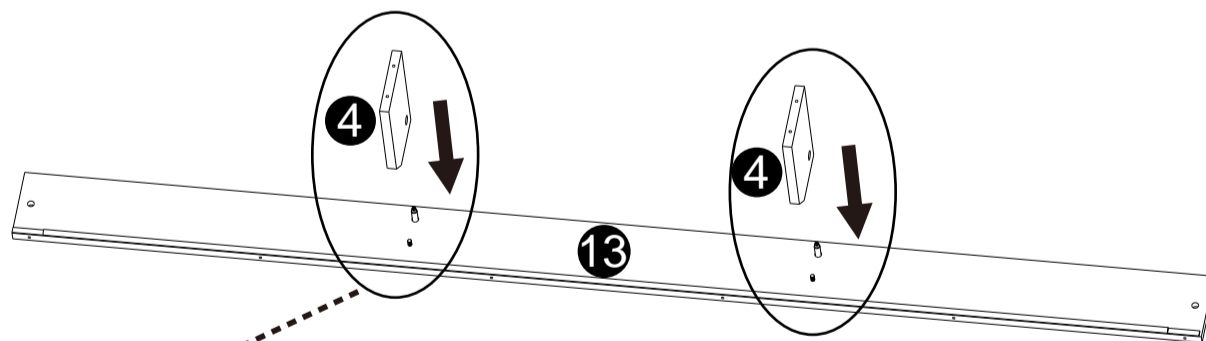
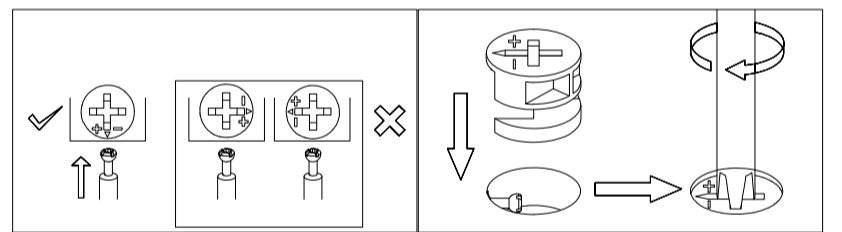
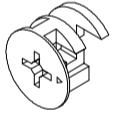

19

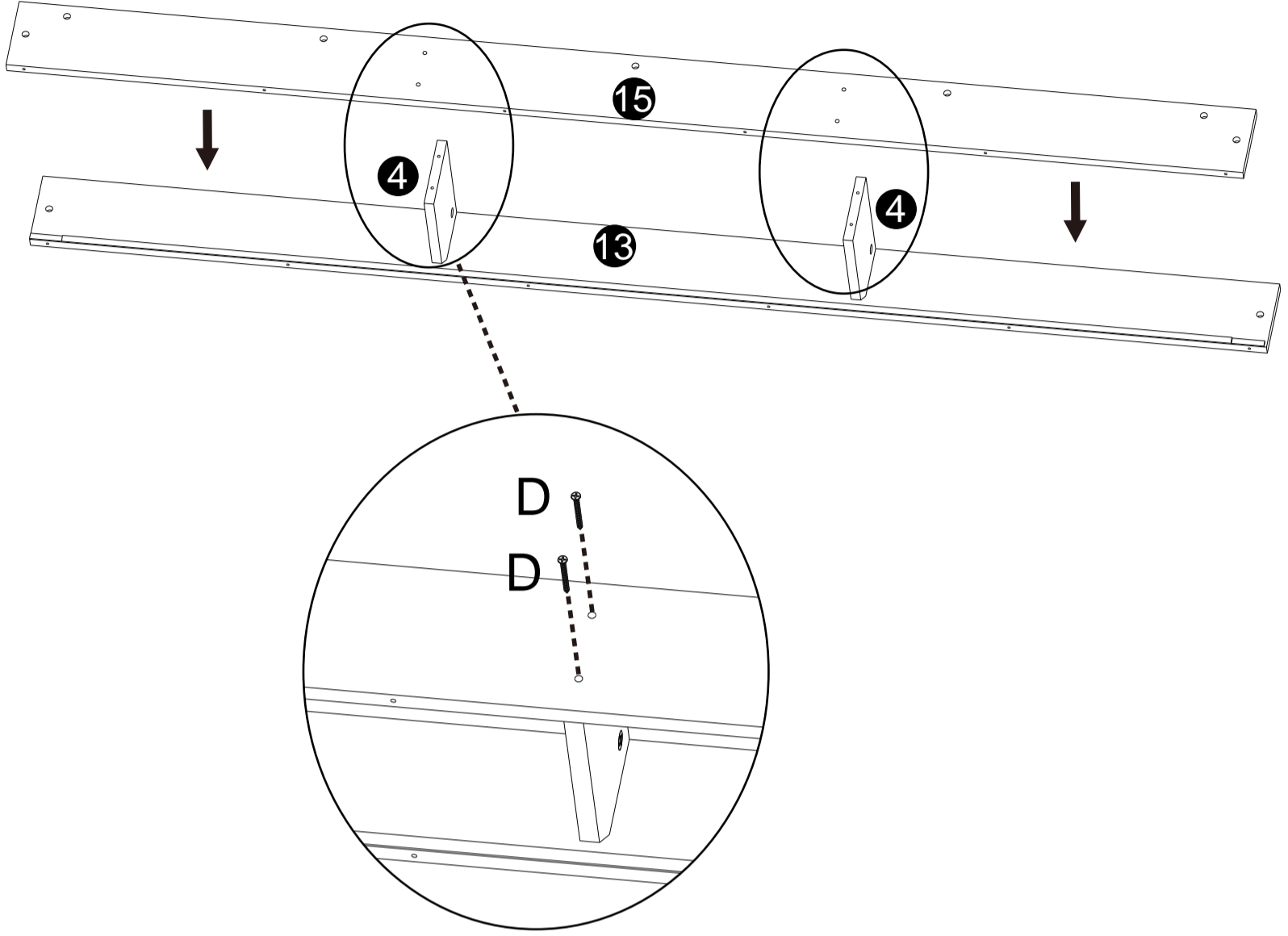
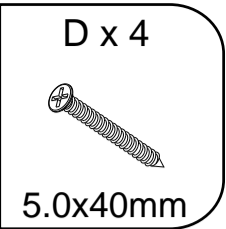

20

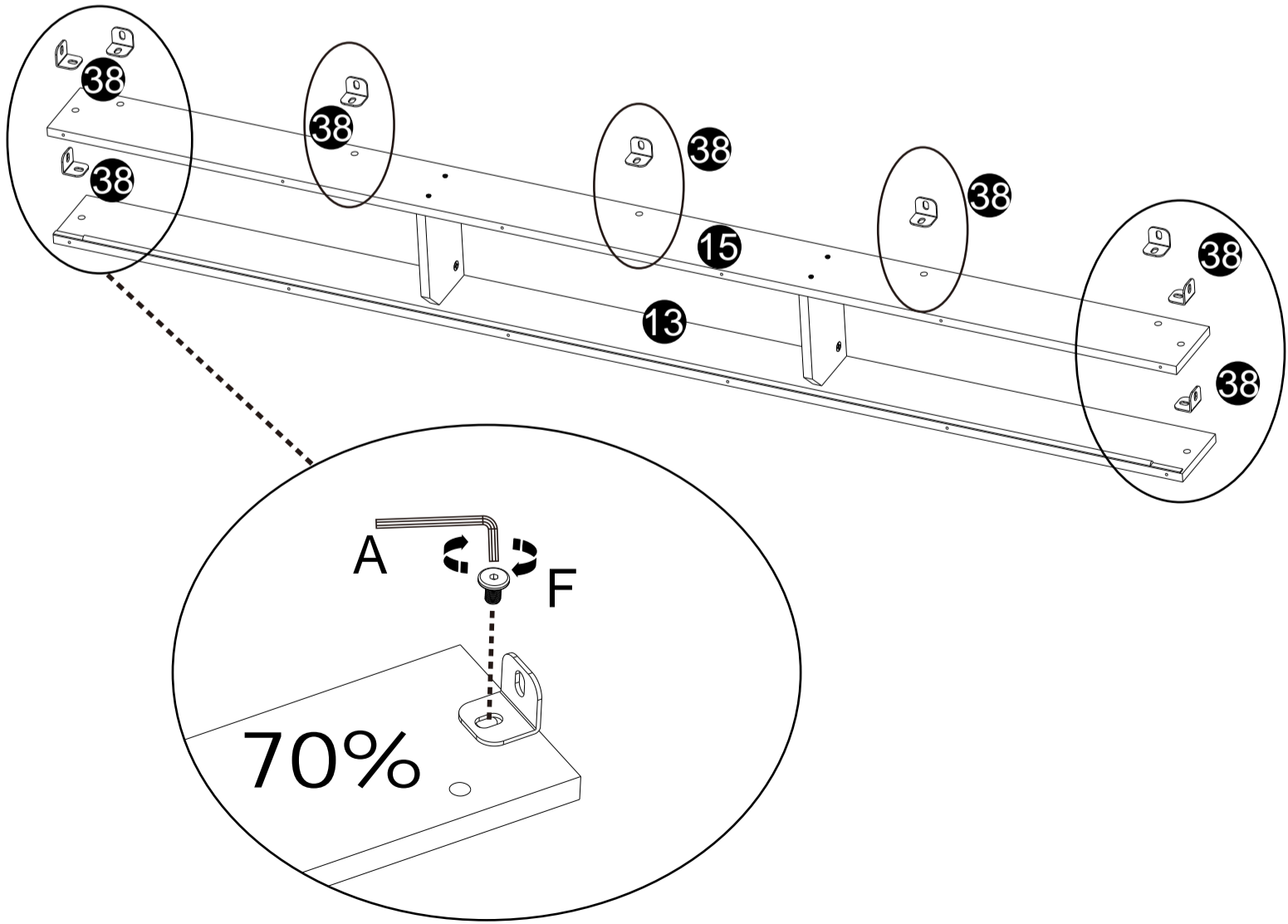
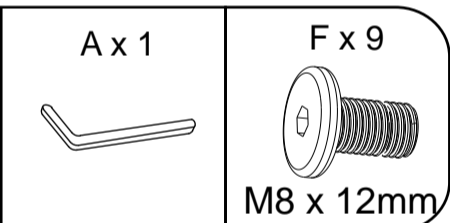

21 D x 12
5.0x40mm

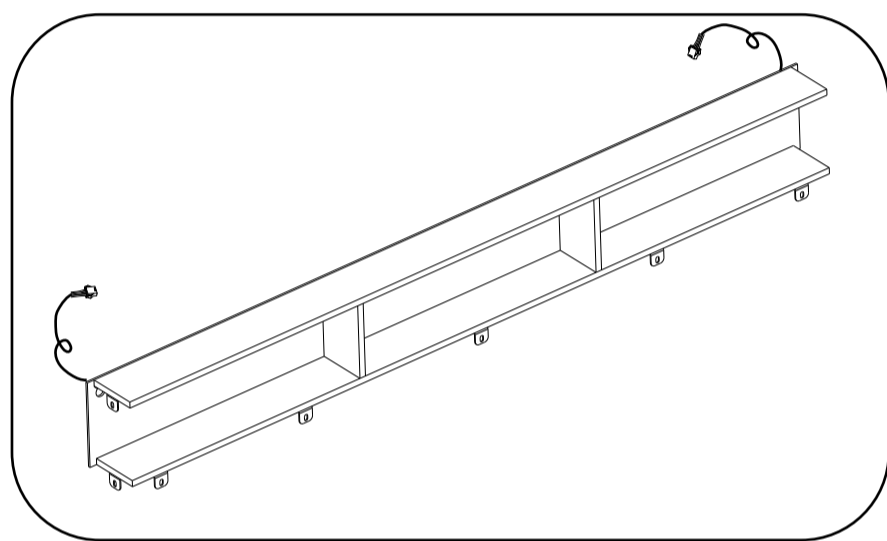
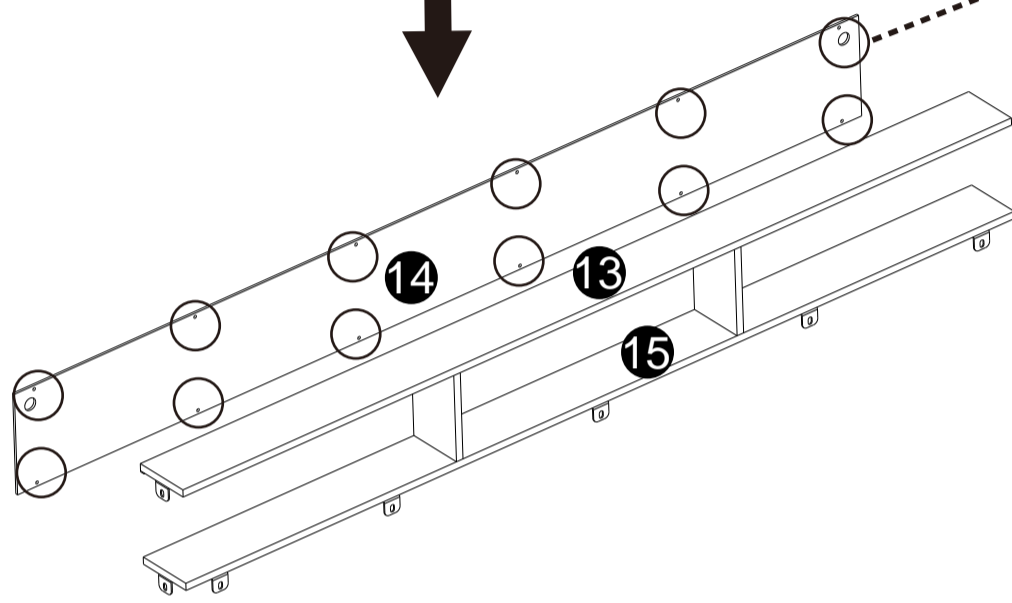
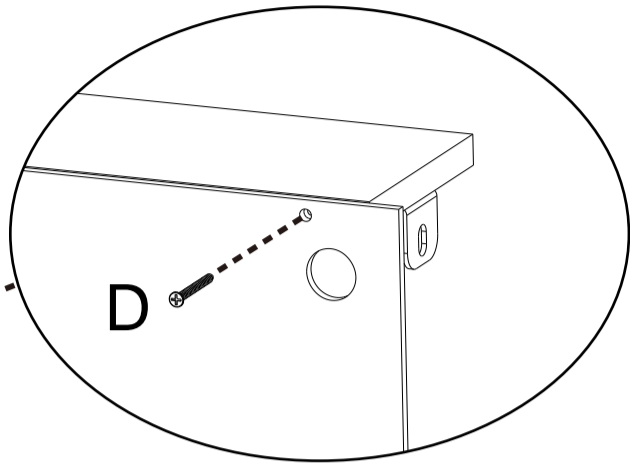
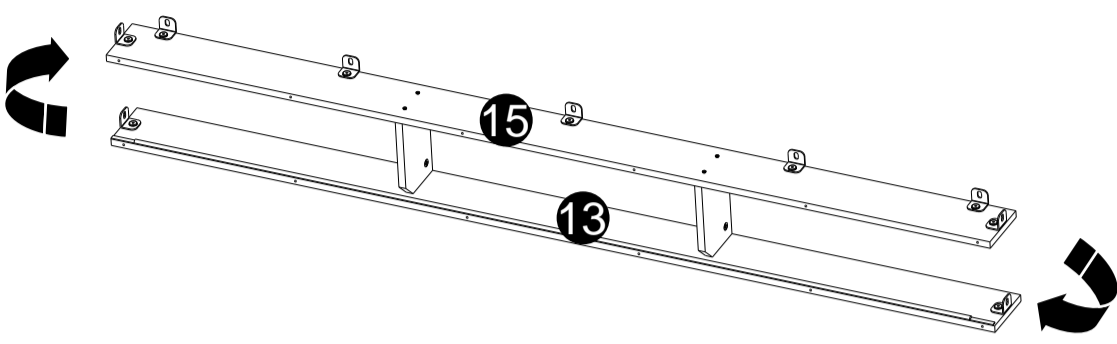
22 A x 1 F x 7
M8 x 12mm



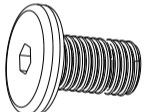
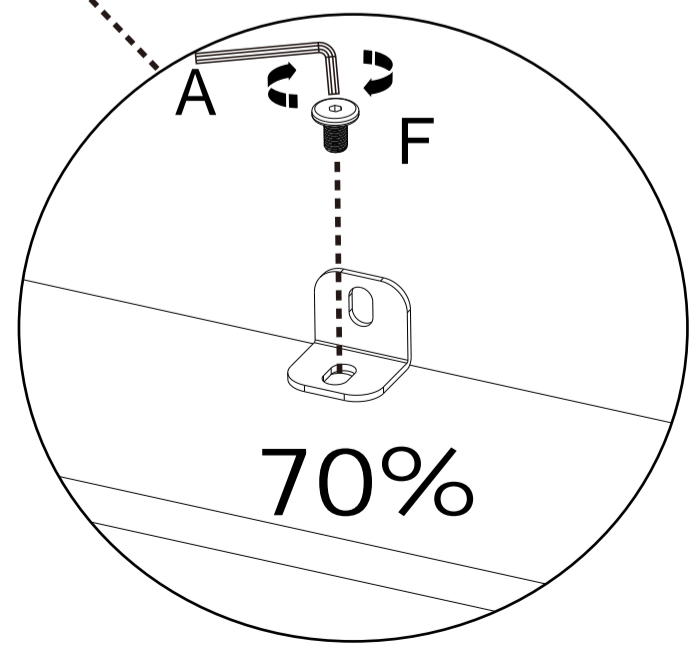
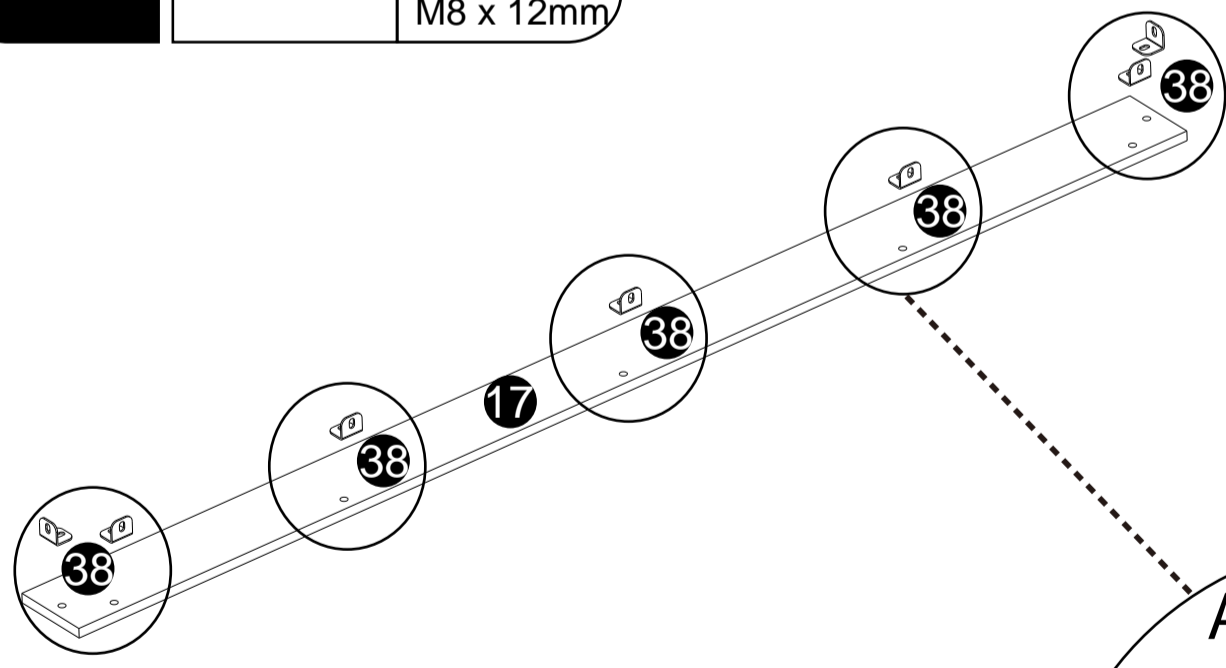

23

A x 1

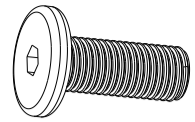

G x 4



M8 x 20mm

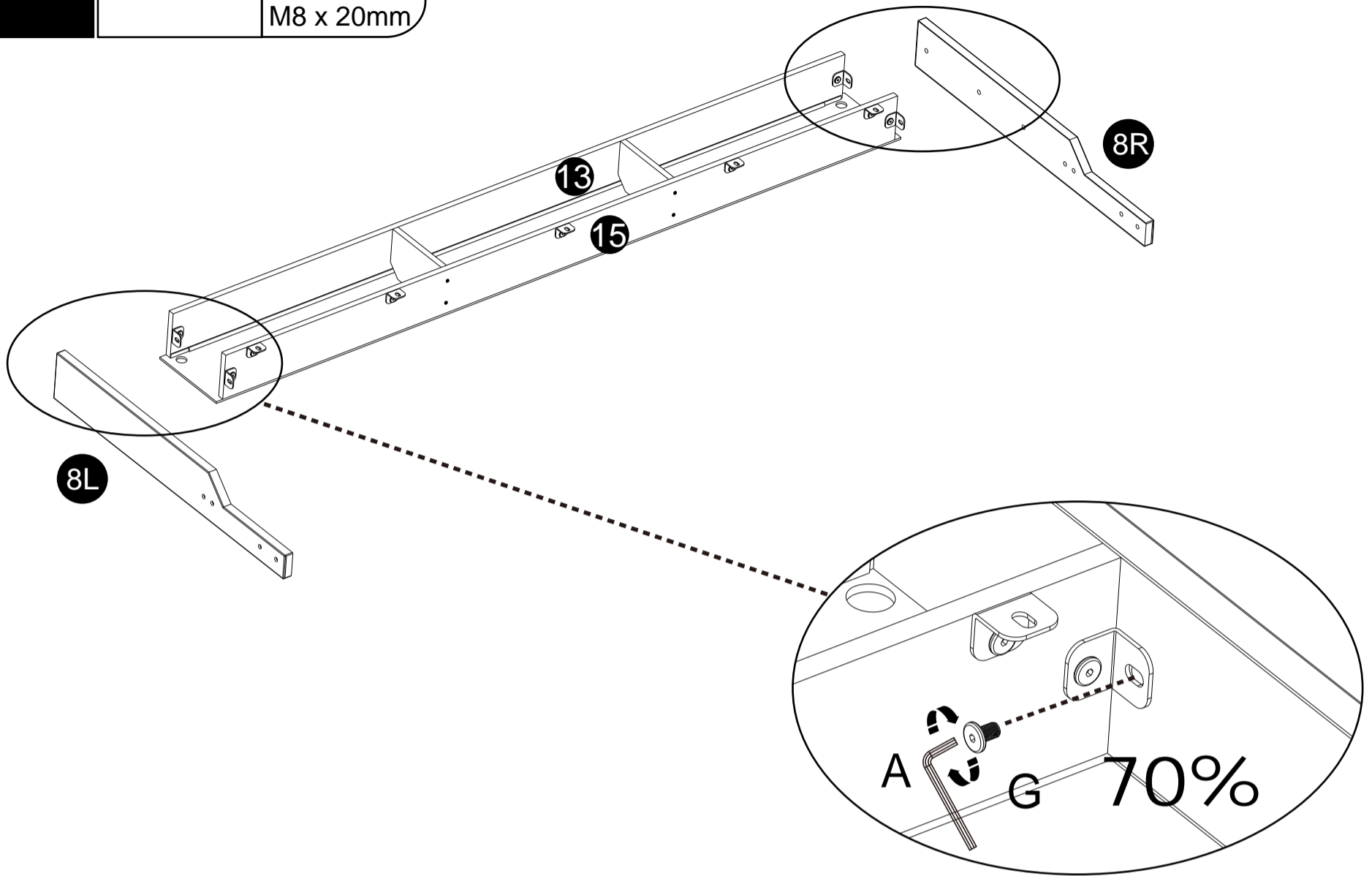

24

A x 1



G x 2

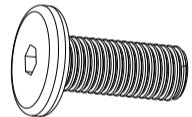

M8 x 20mm

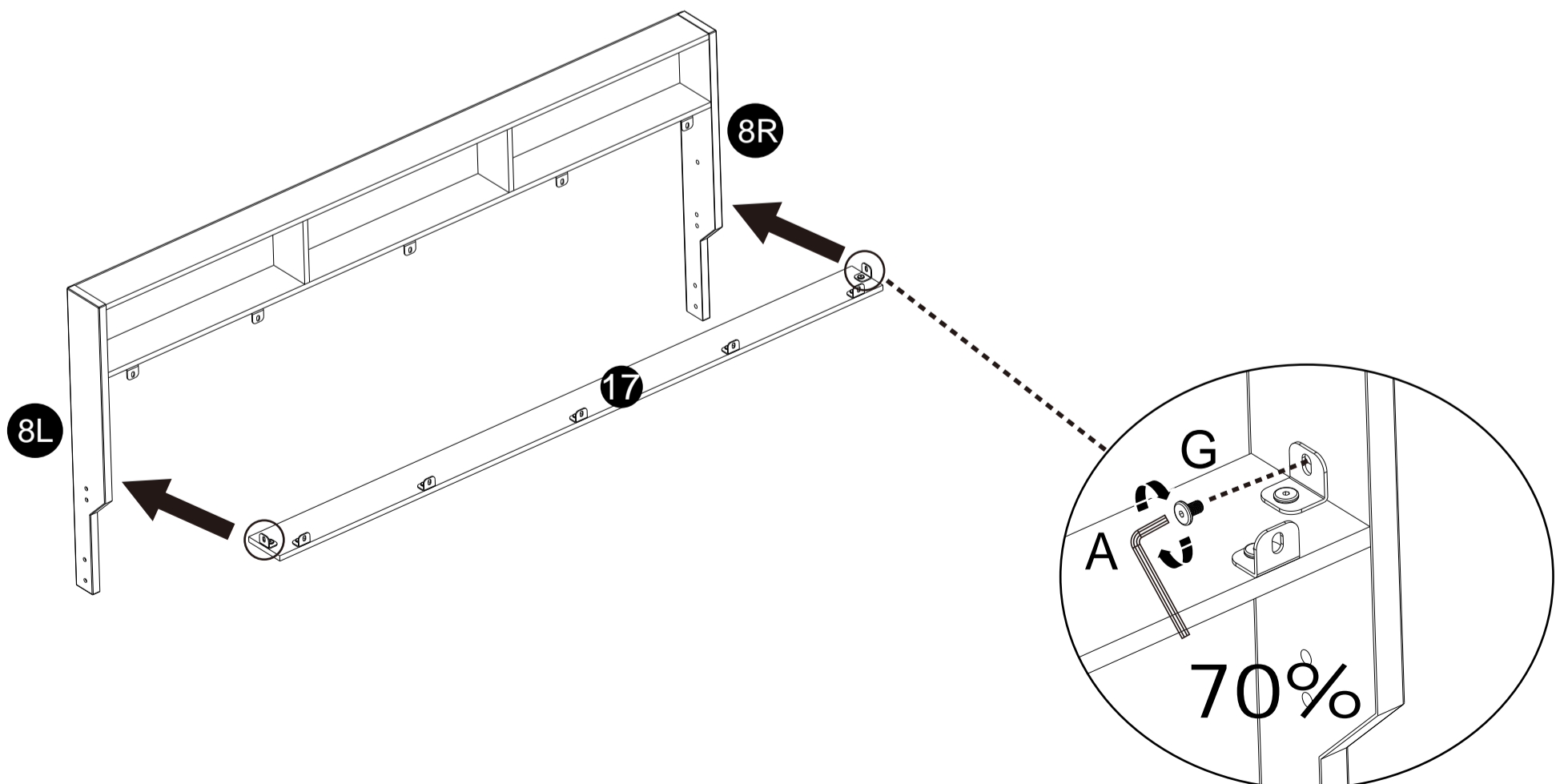

25

A x 1



G x 10

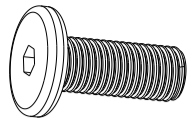

M8 x 20mm

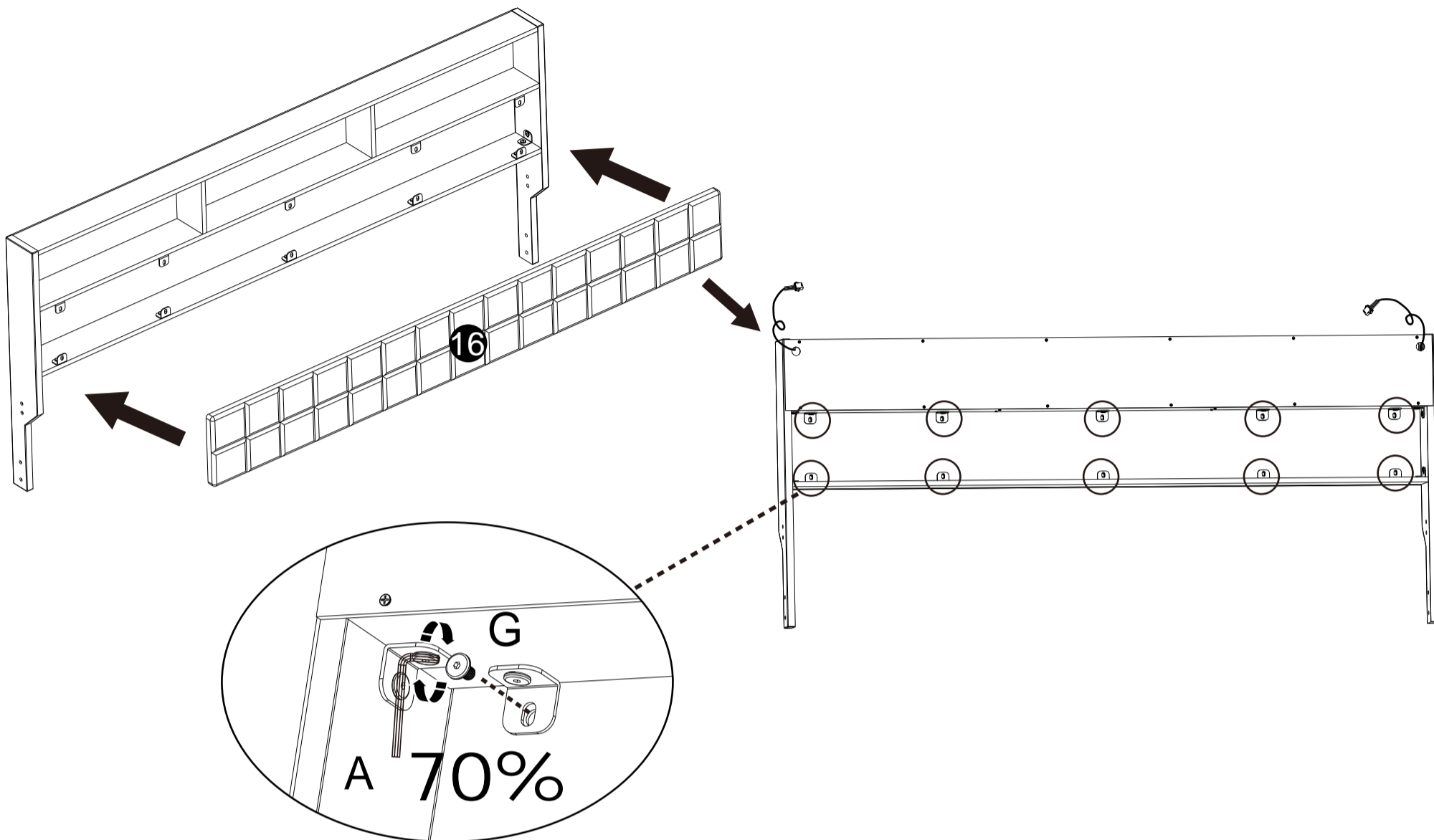

26

A x 1

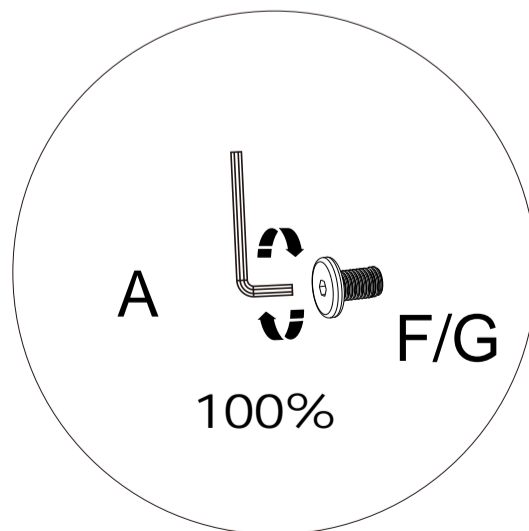
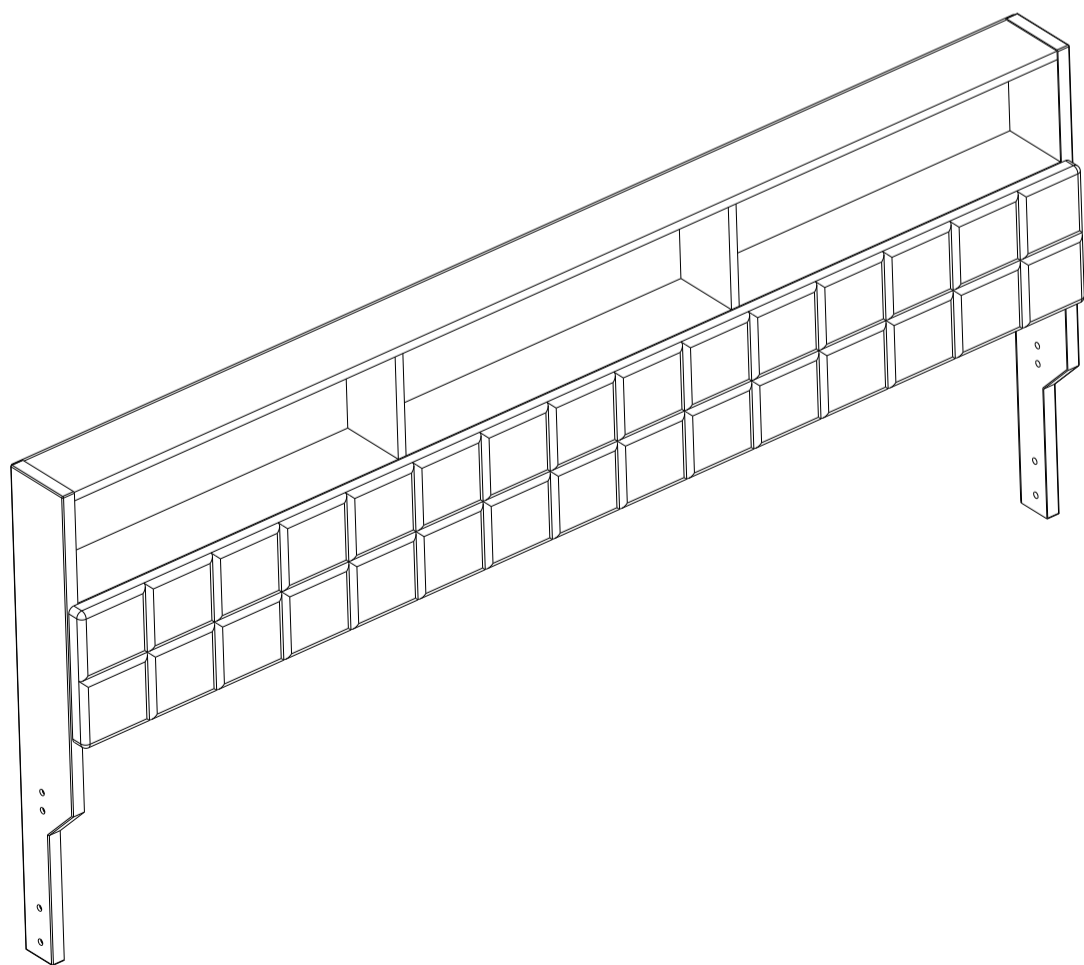

27

A x 1



K x 2



M6 x 30mm

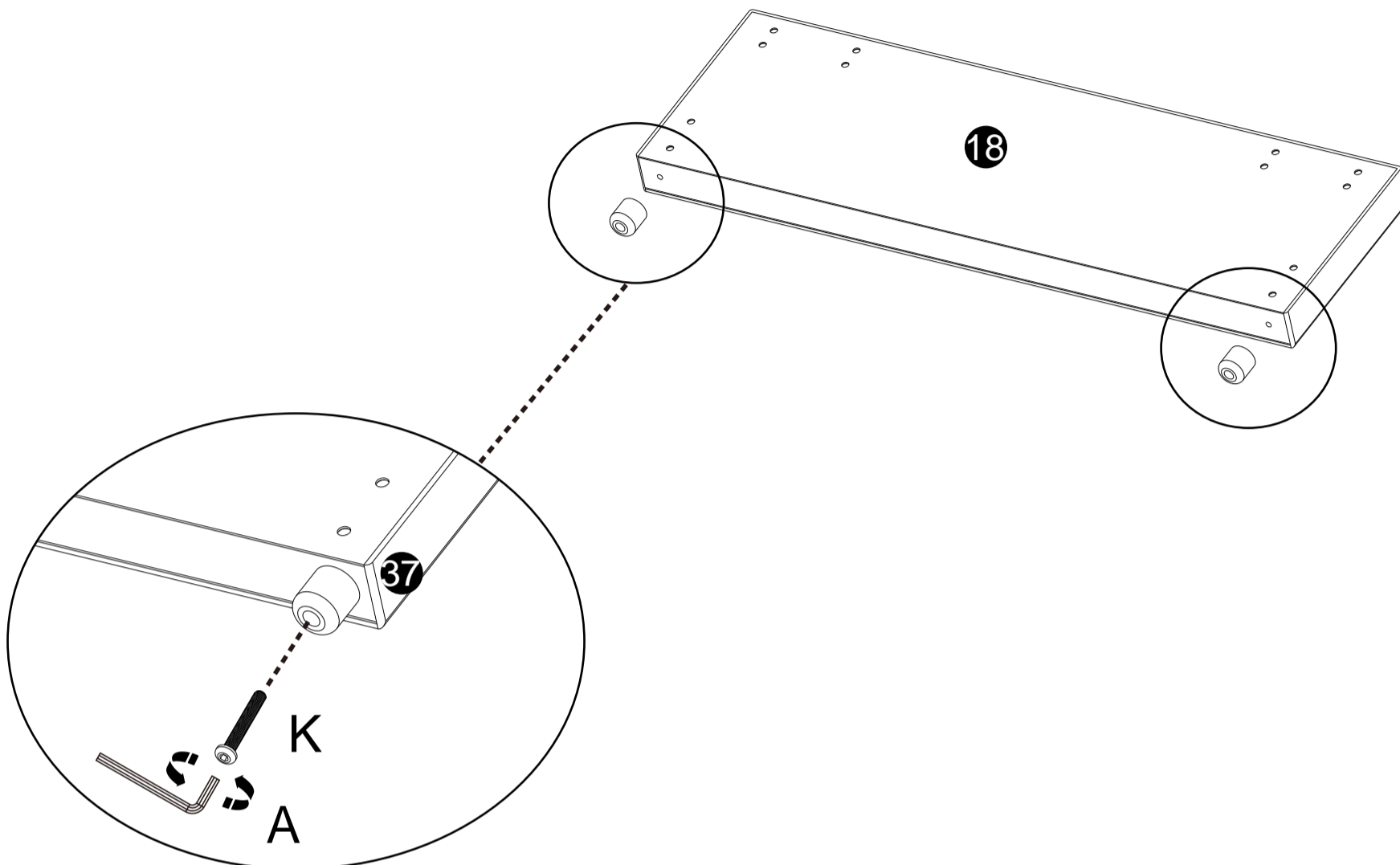

28

A x 1



L x 6



M6 x 35mm

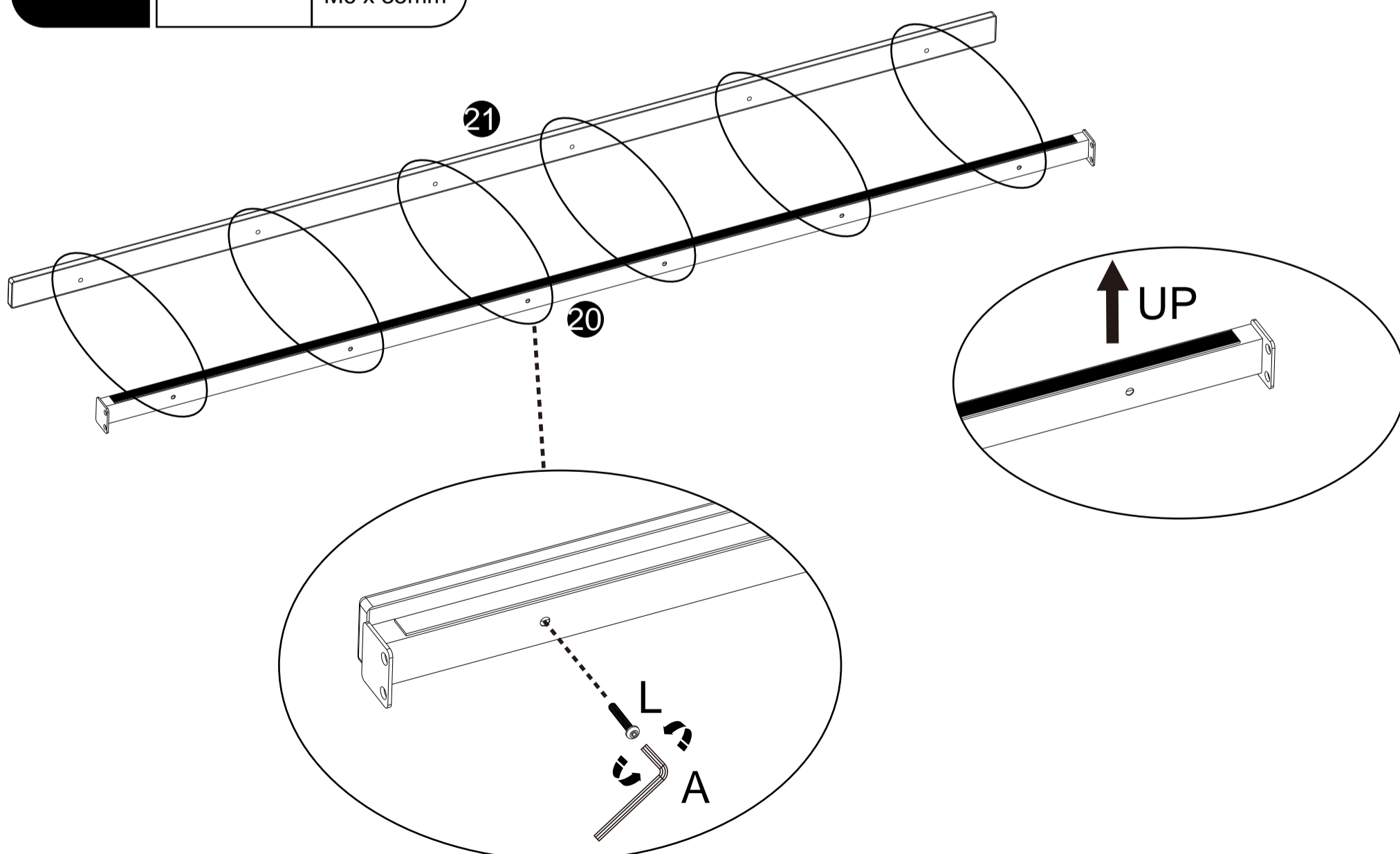

29L

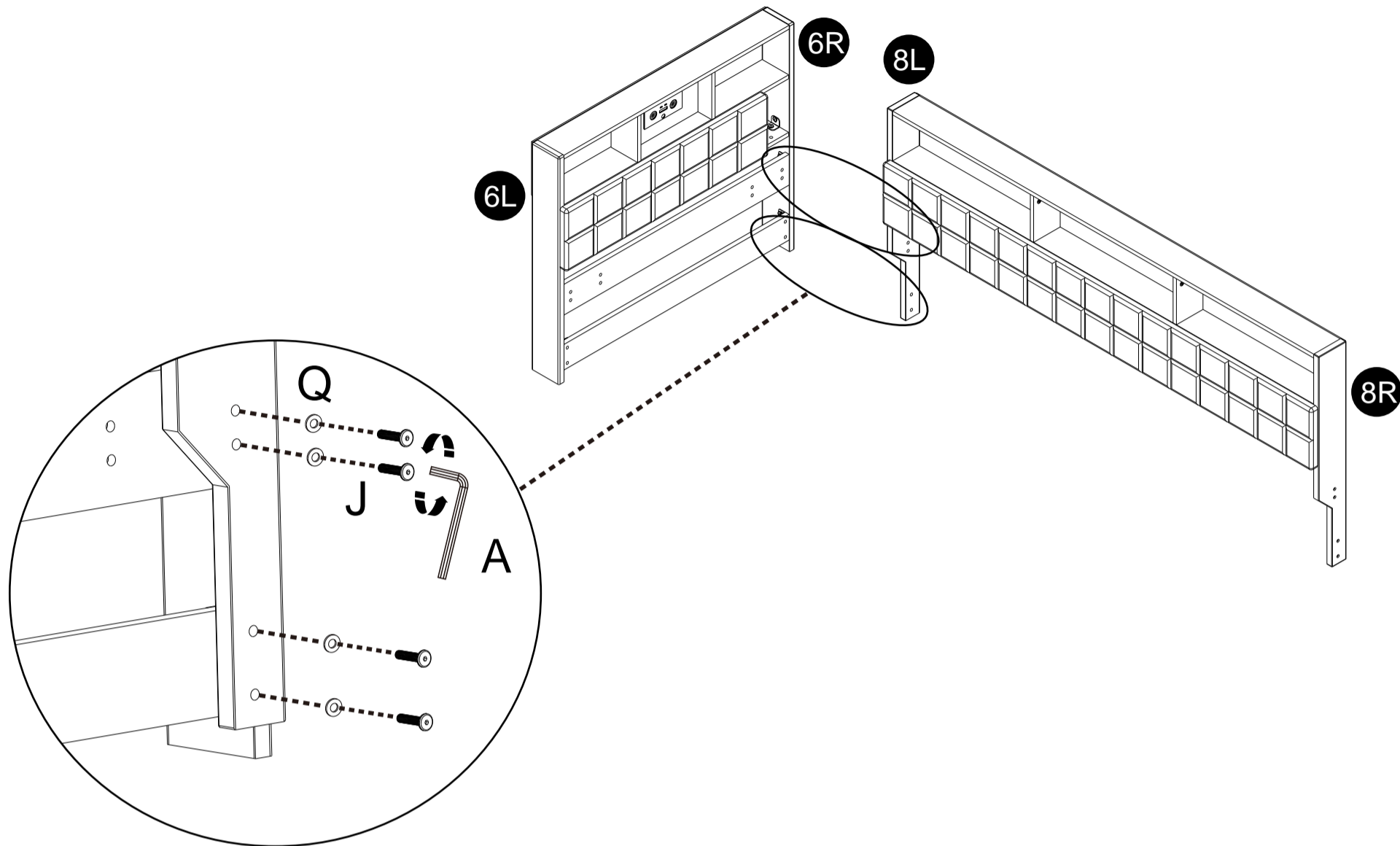
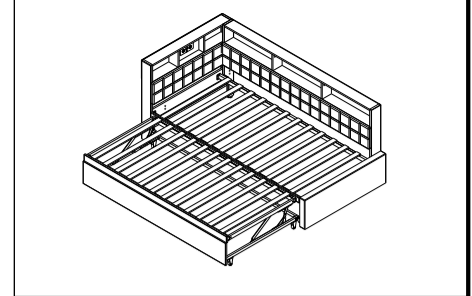
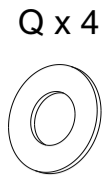
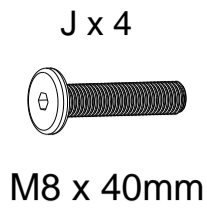
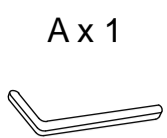

29R

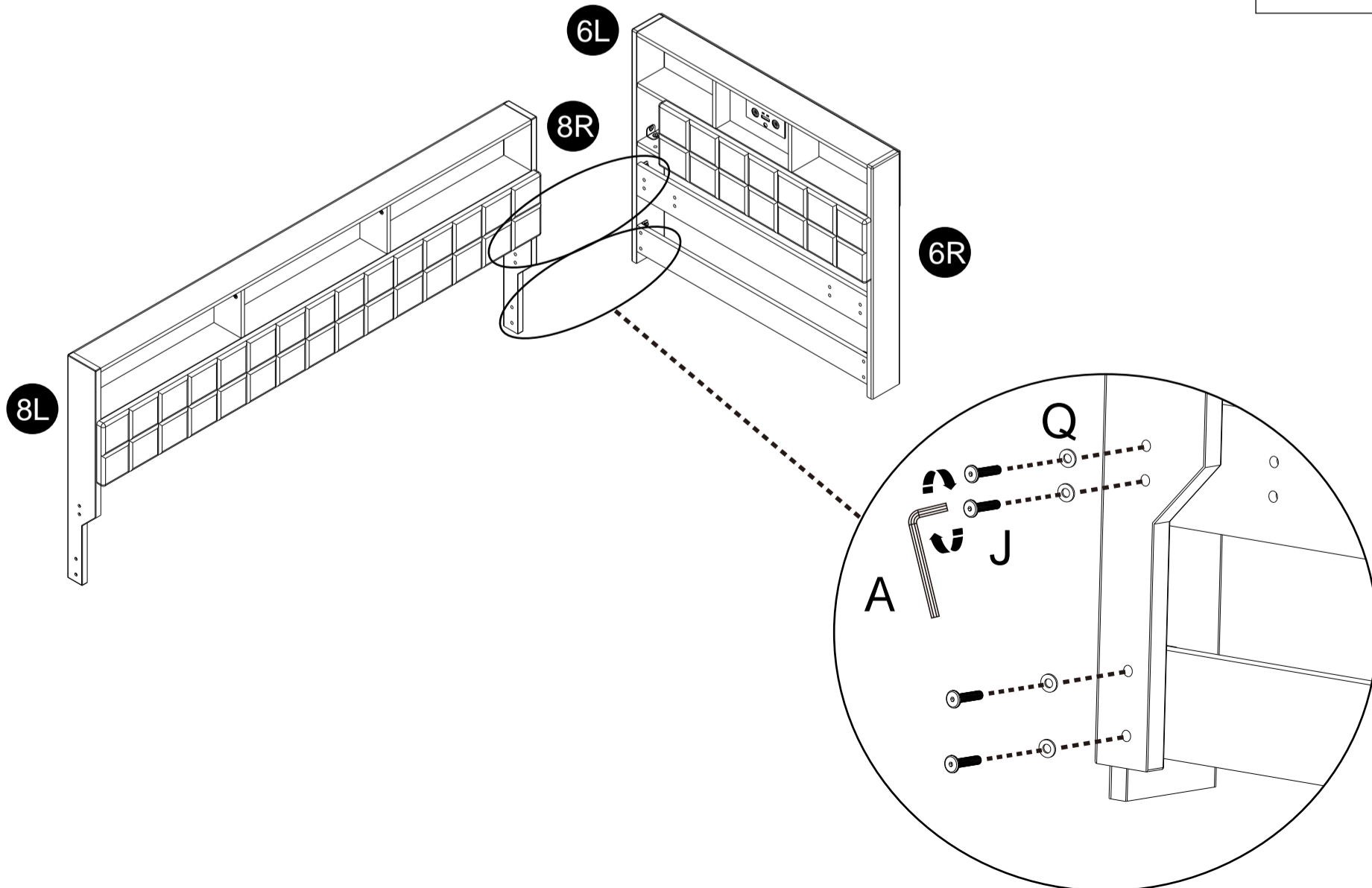
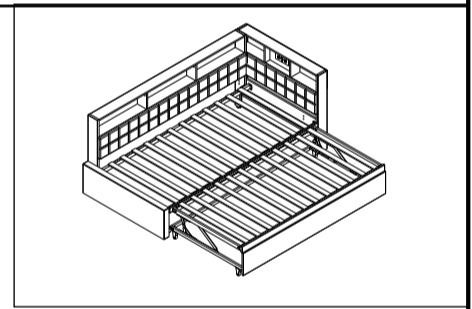
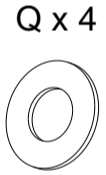
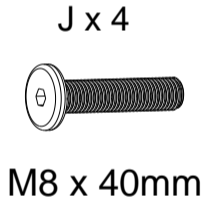
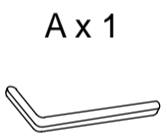

30L

A x 1



J x 4

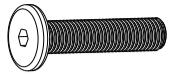

M8 x 40mm

Q x 4

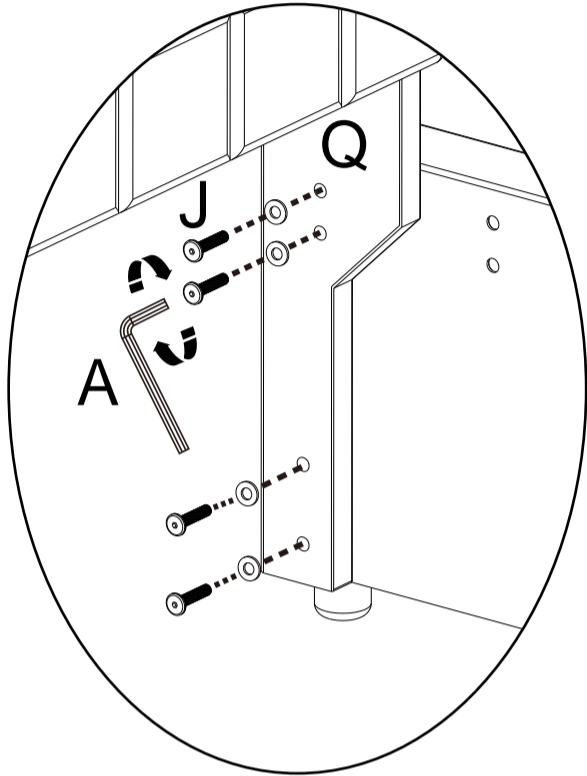
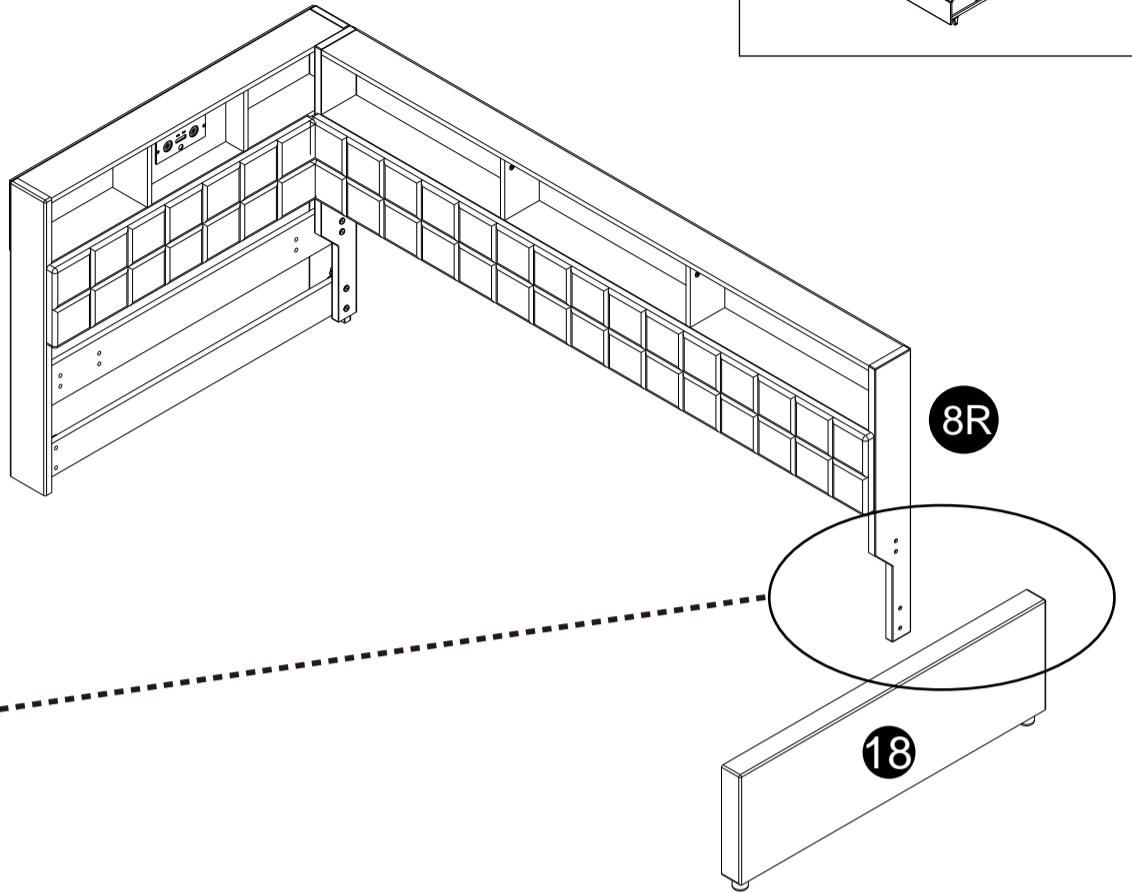
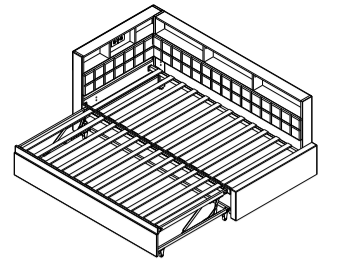
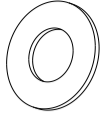

30R

A x 1



J x 4

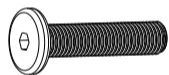

M8 x 40mm

Q x 4

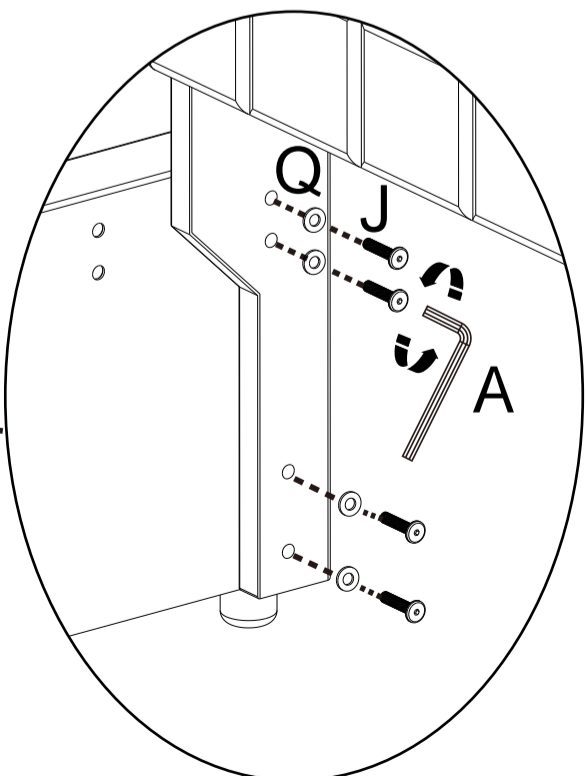
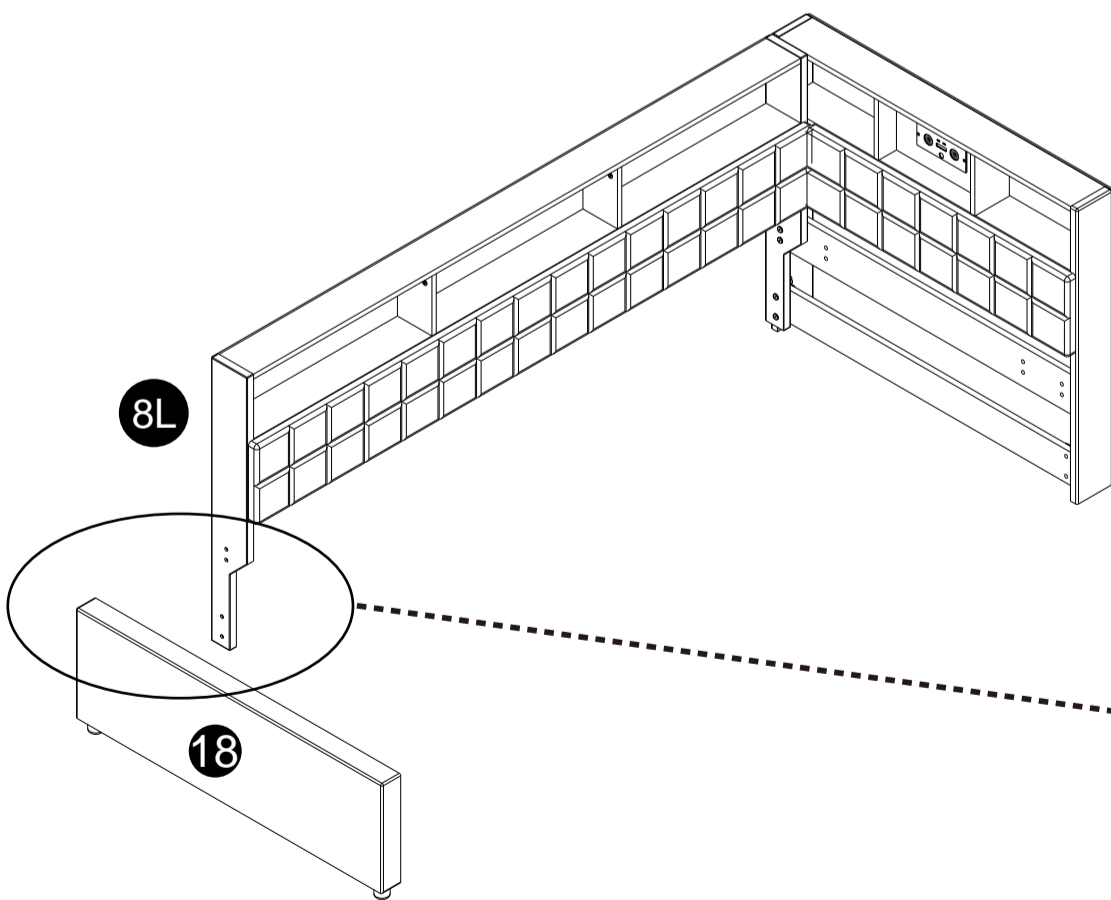
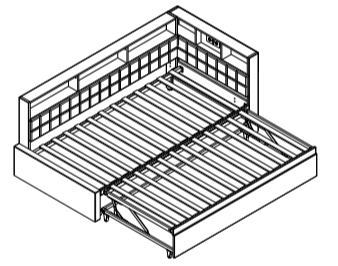

31L

A x 1



G x 8

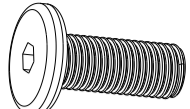

M8 x 20mm

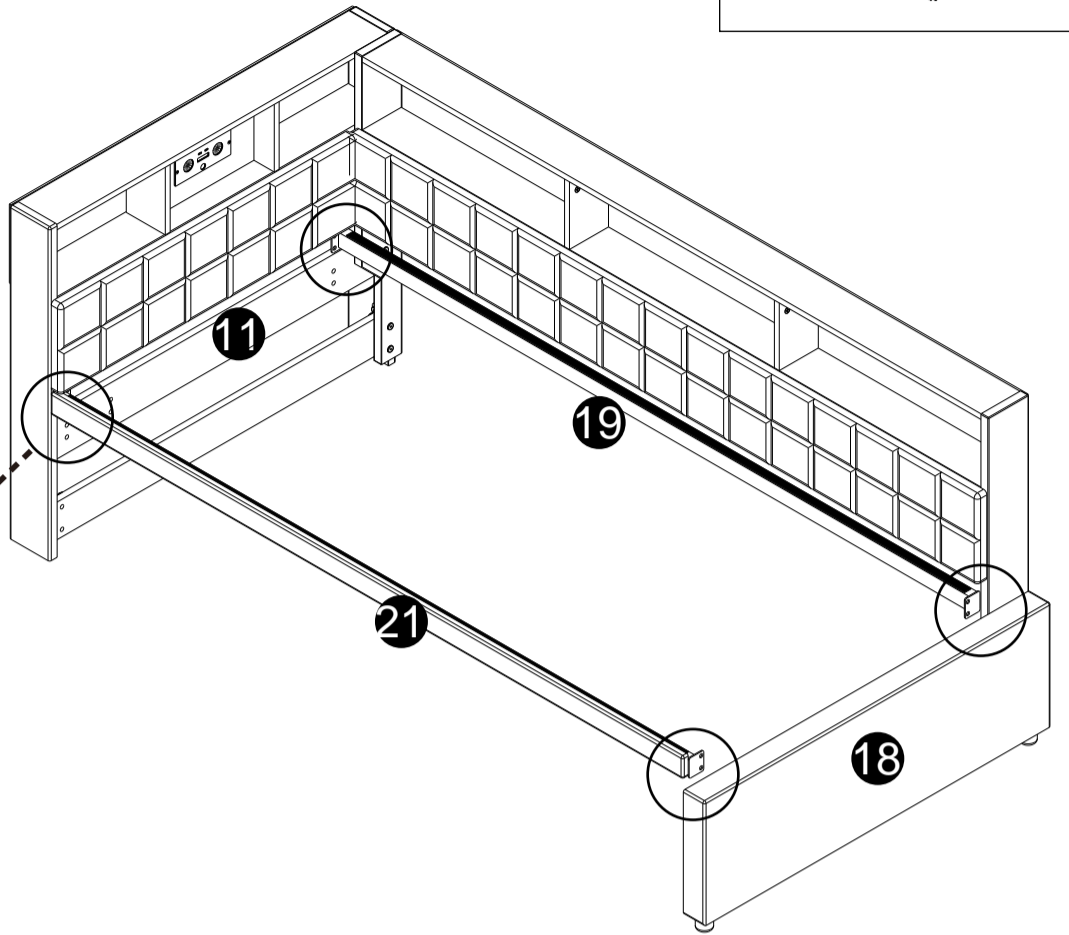
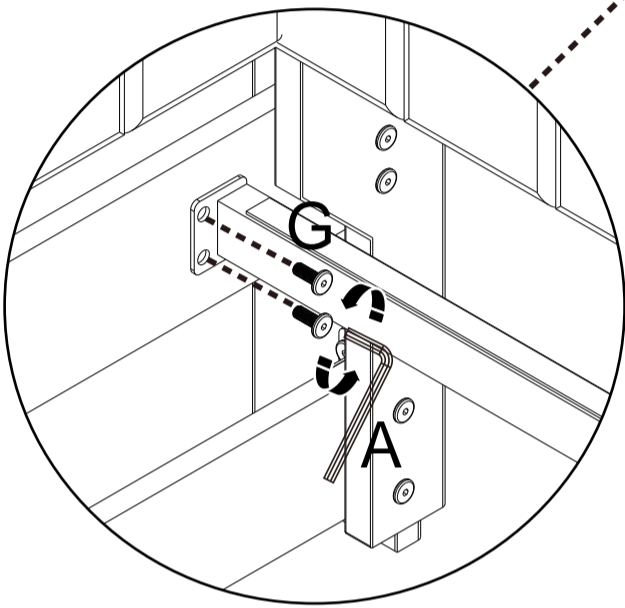
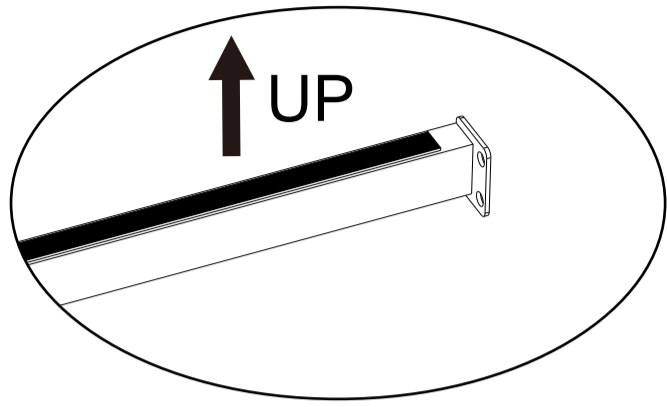
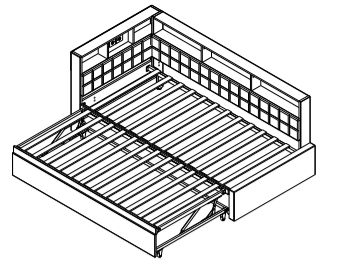

31R

A x 1



G x 8

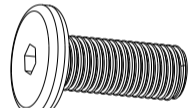

M8 x 20mm

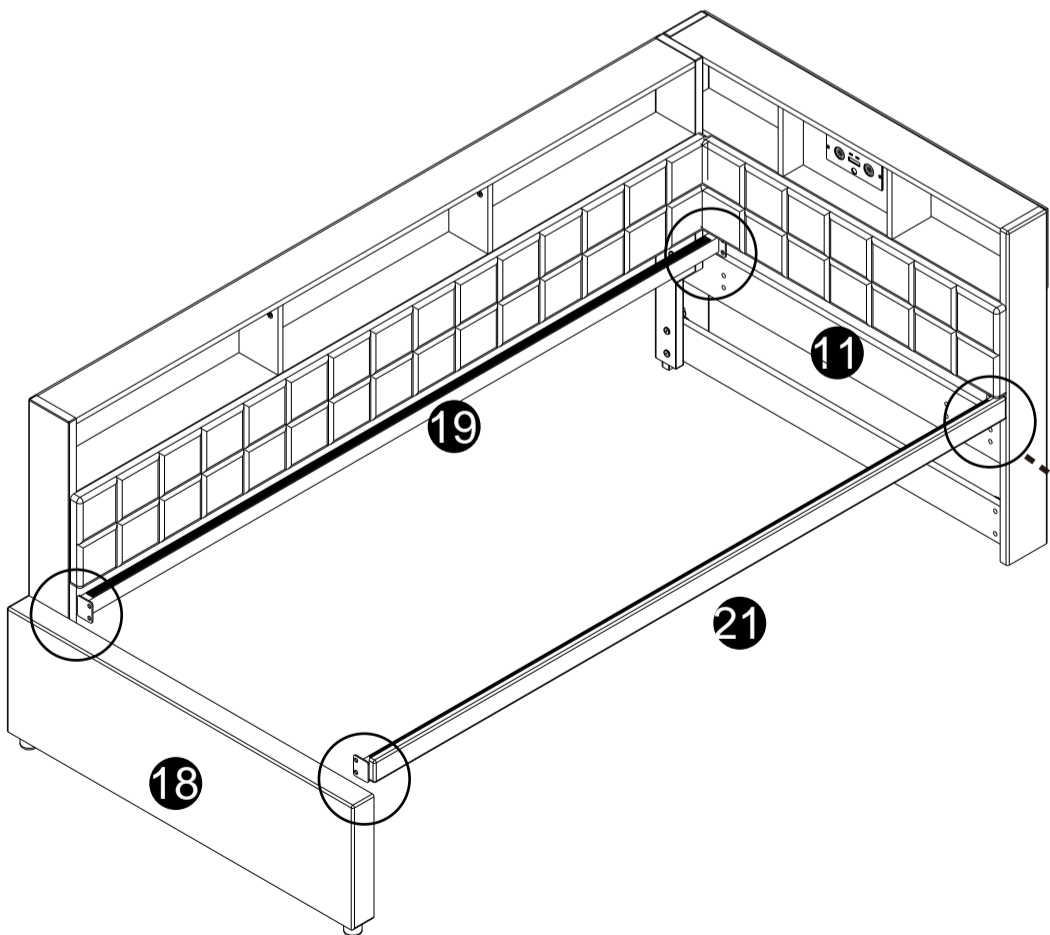
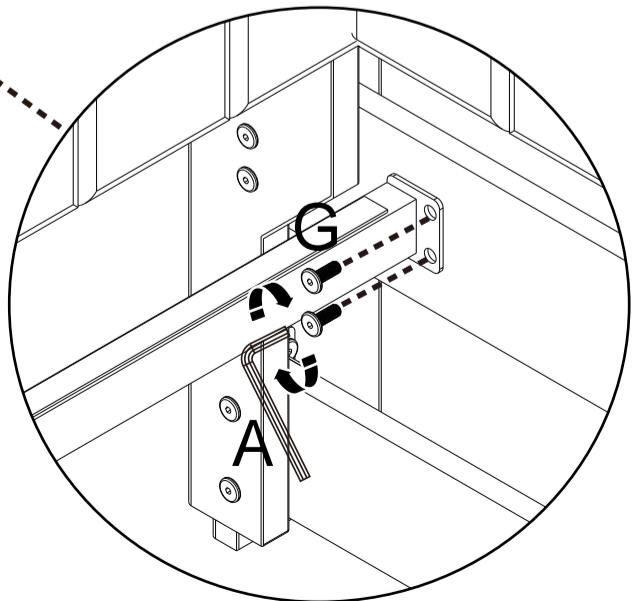
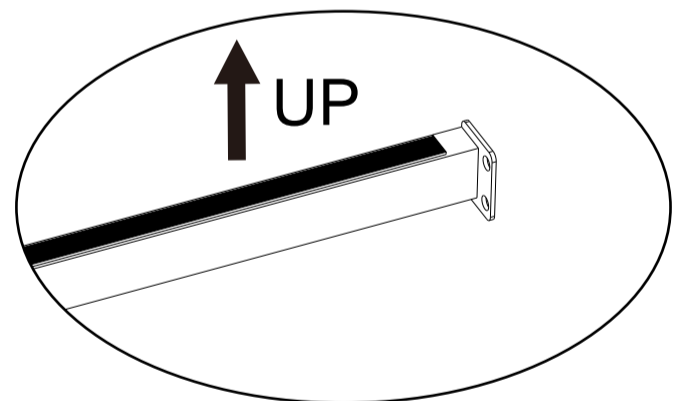
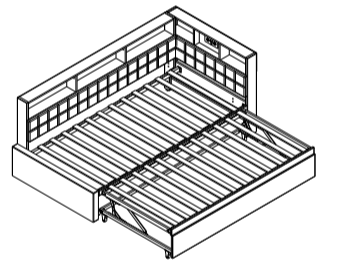

32

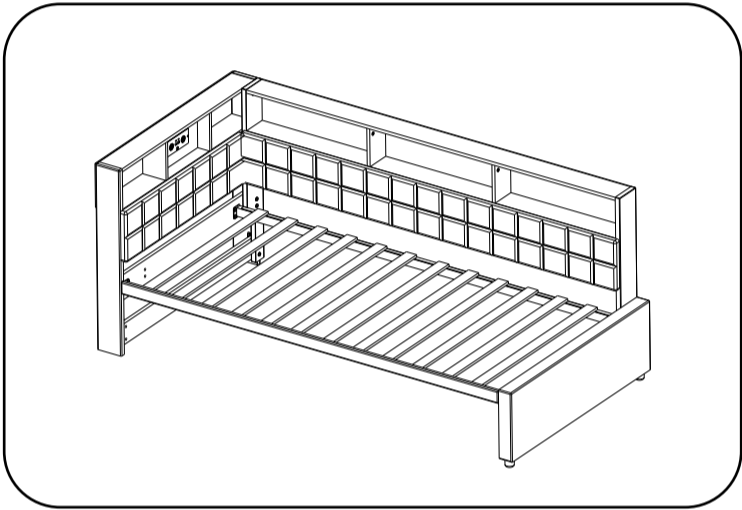
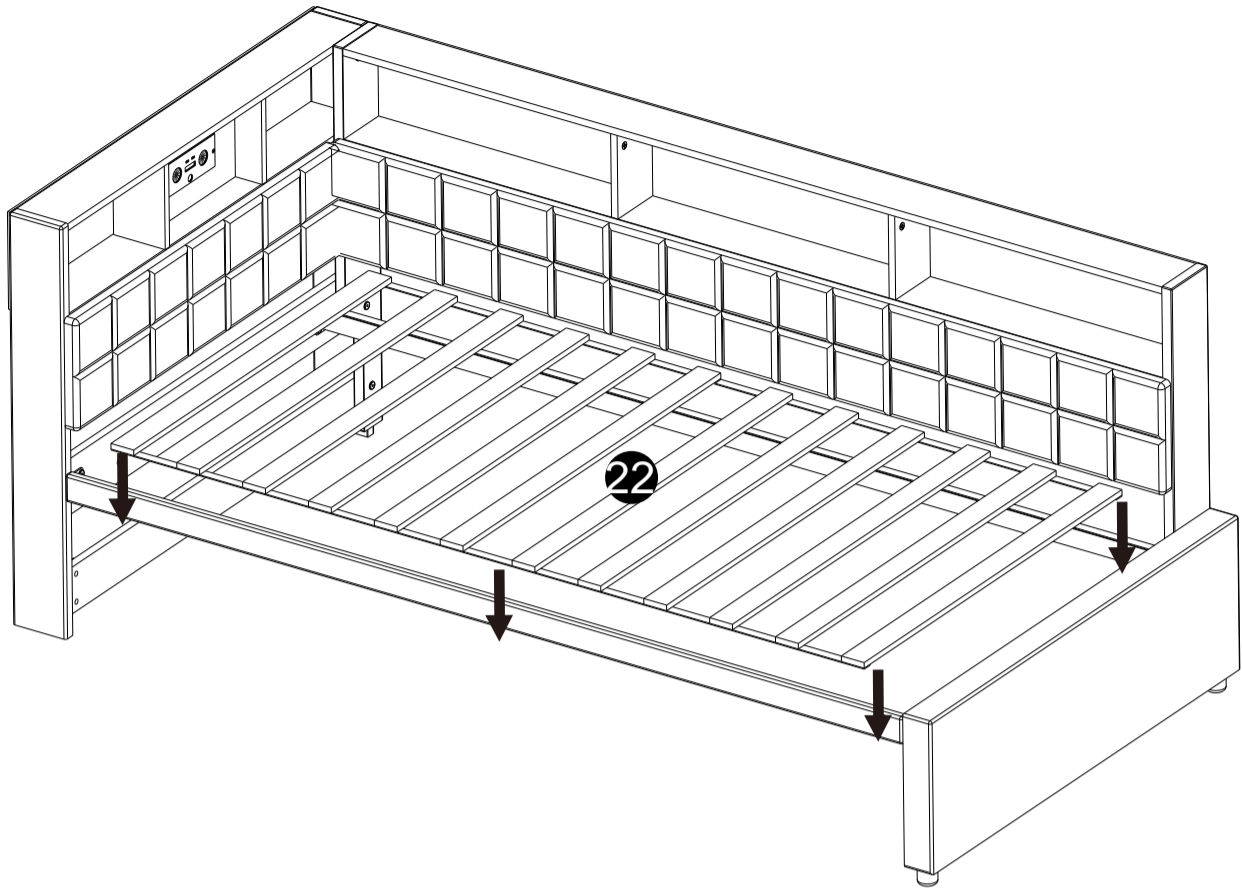

33

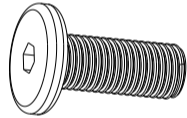
A x 1	G x 4
	
	M8 x 20mm

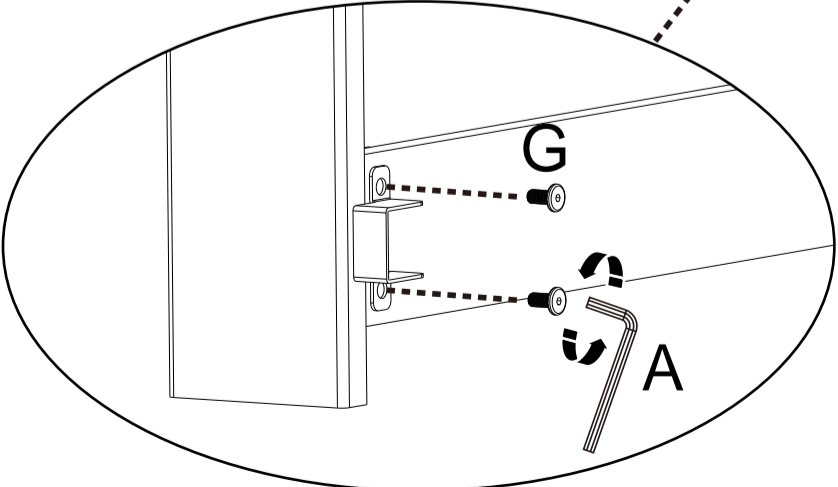
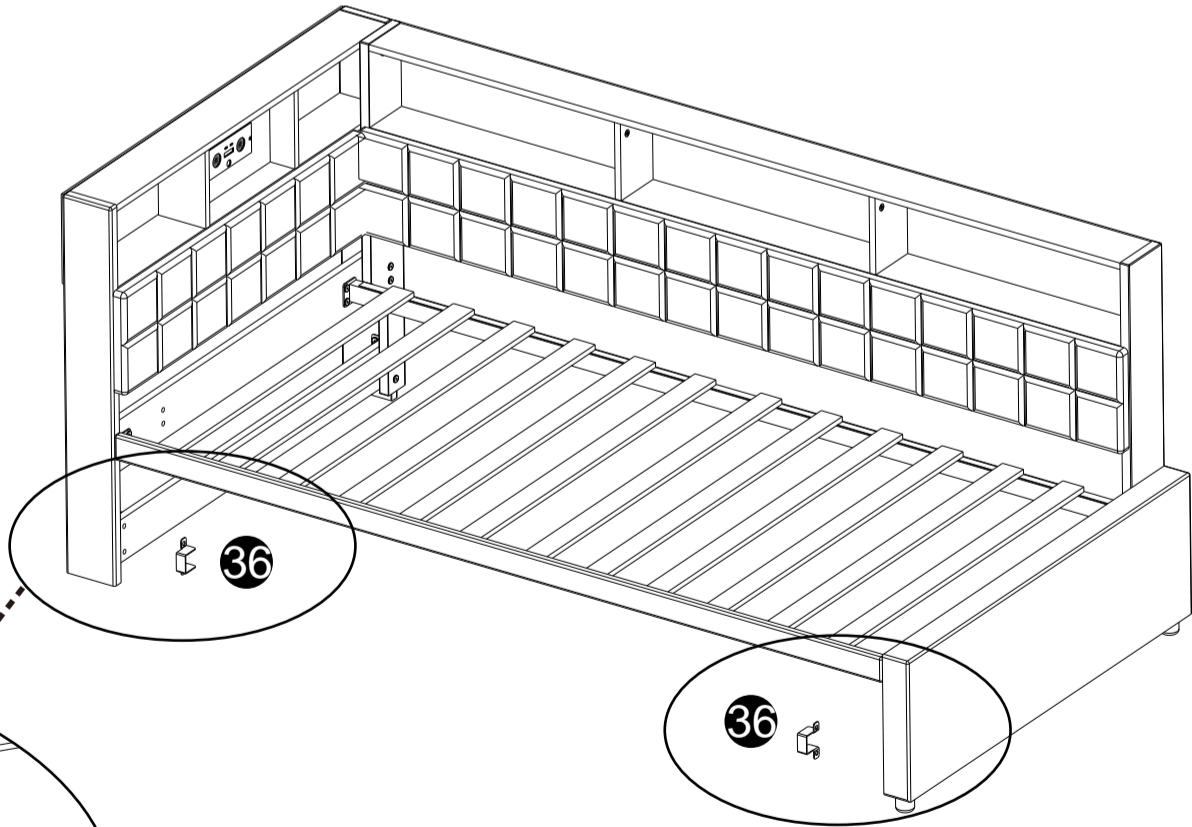

34

C x 4



4.0x15mm

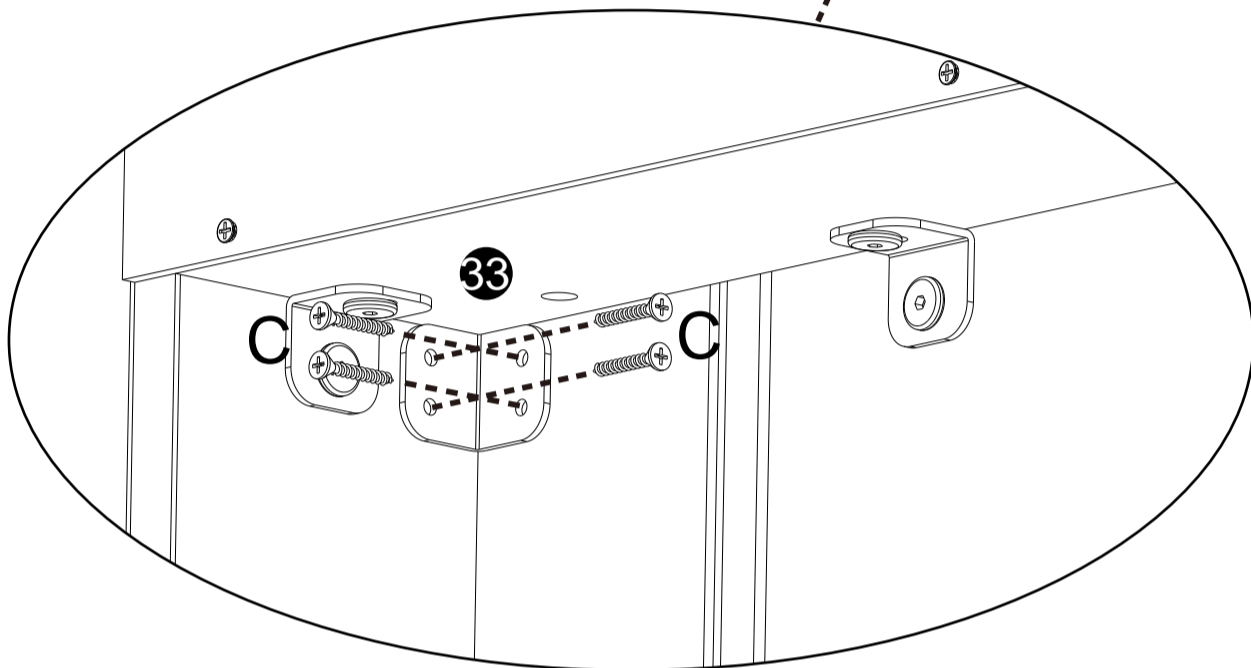
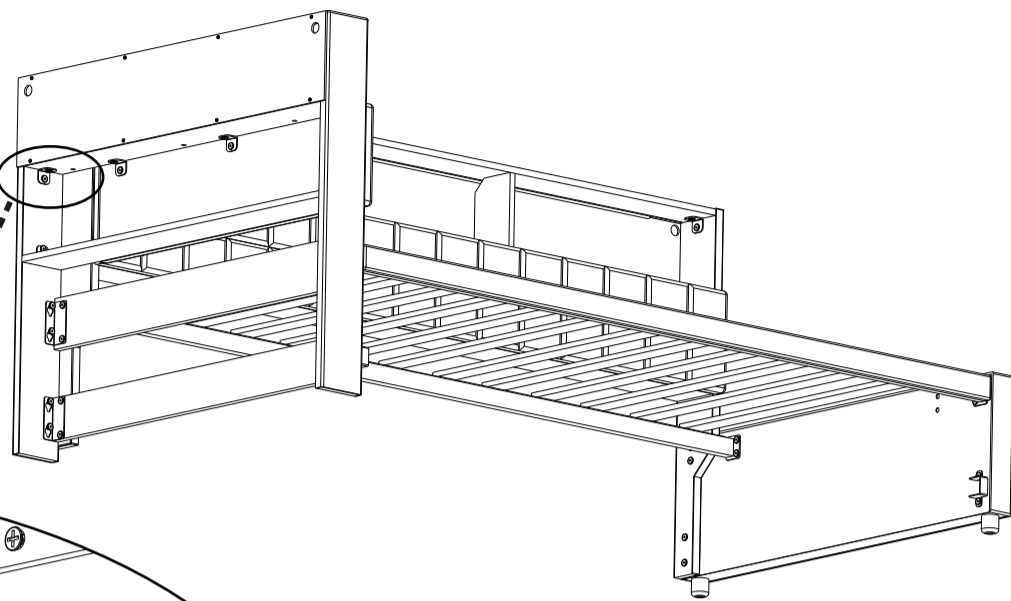

35

A x 1



B x 4



M4 x 10mm

G x 8

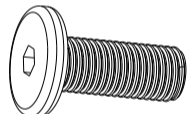

M8 x 20mm

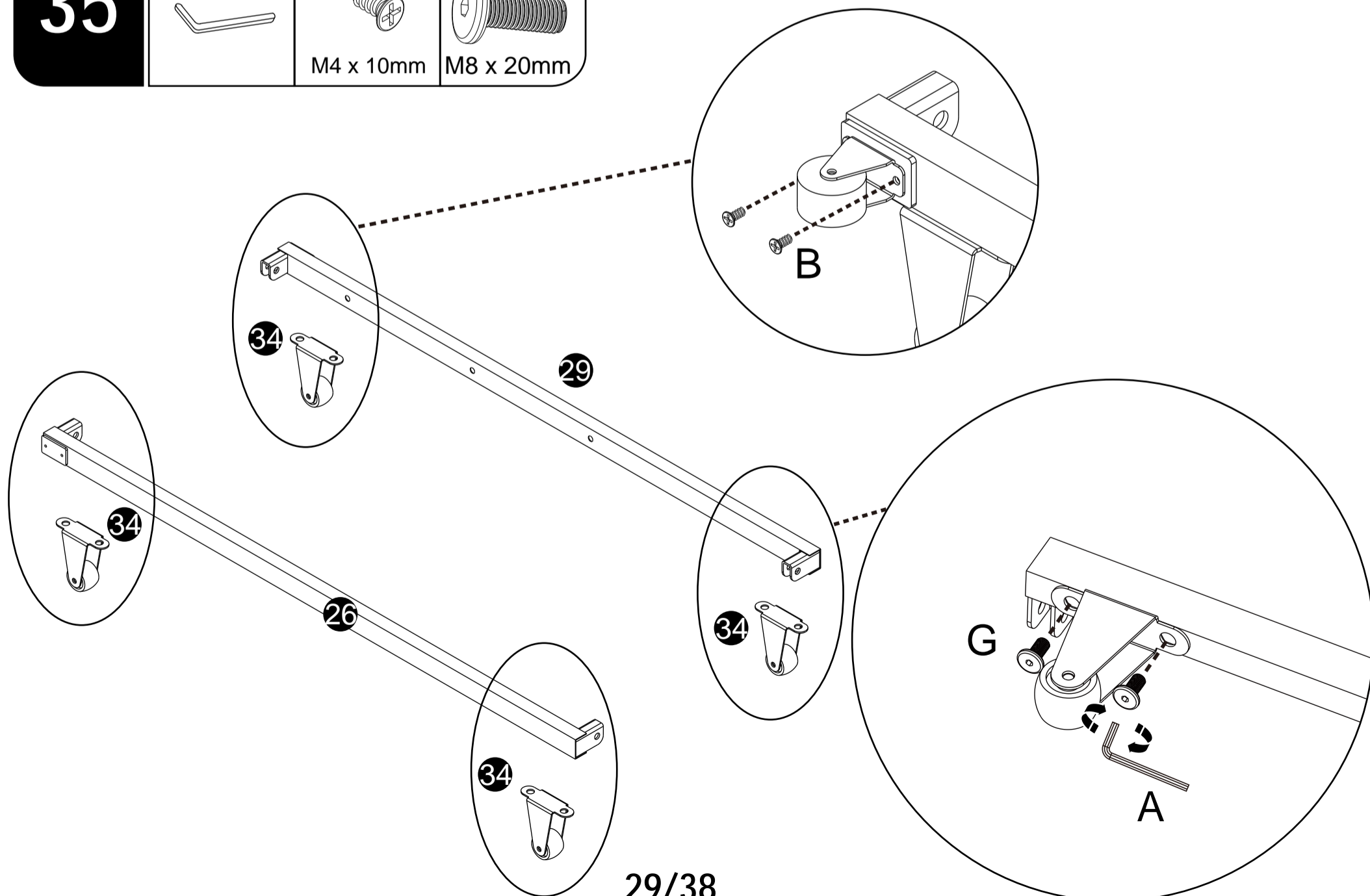

29/38

36

A x 1



H x 4

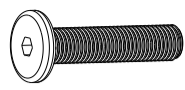

M8 x 30mm

P x 4

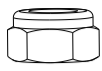

M8

Q x 4

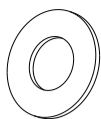

R x 1

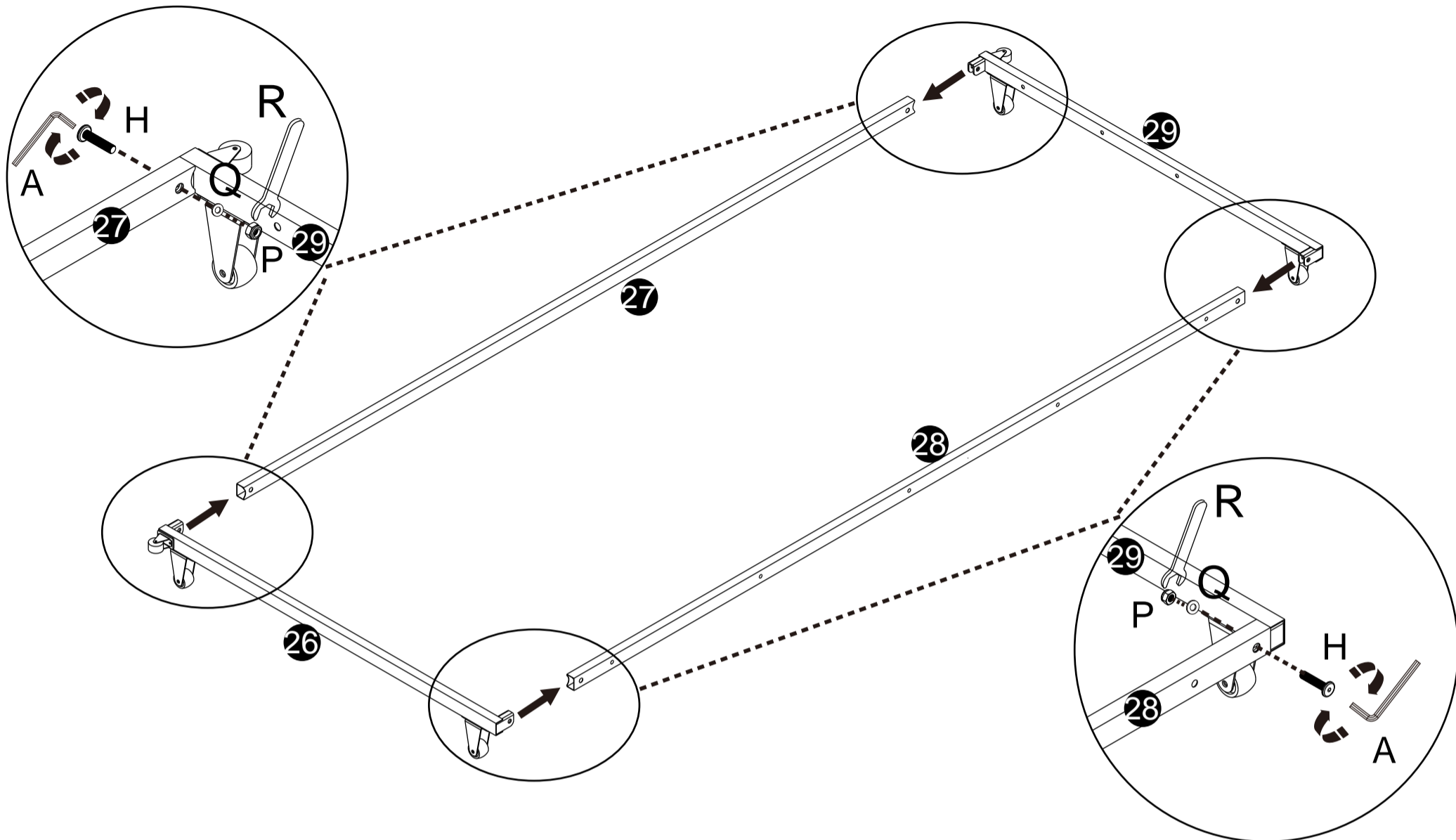

37

A x 1



E x 6



M6 x 16mm

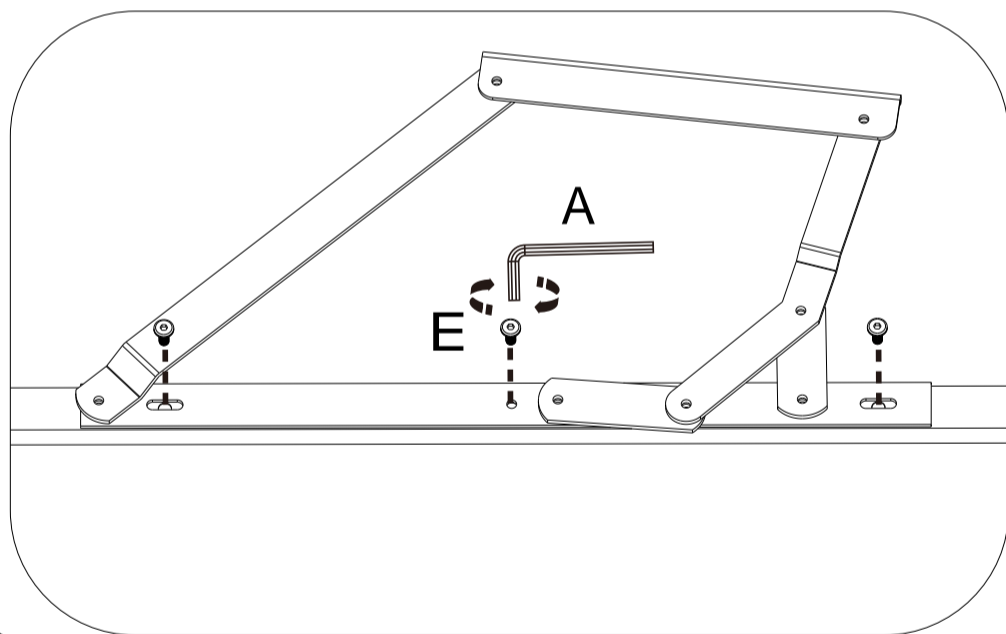
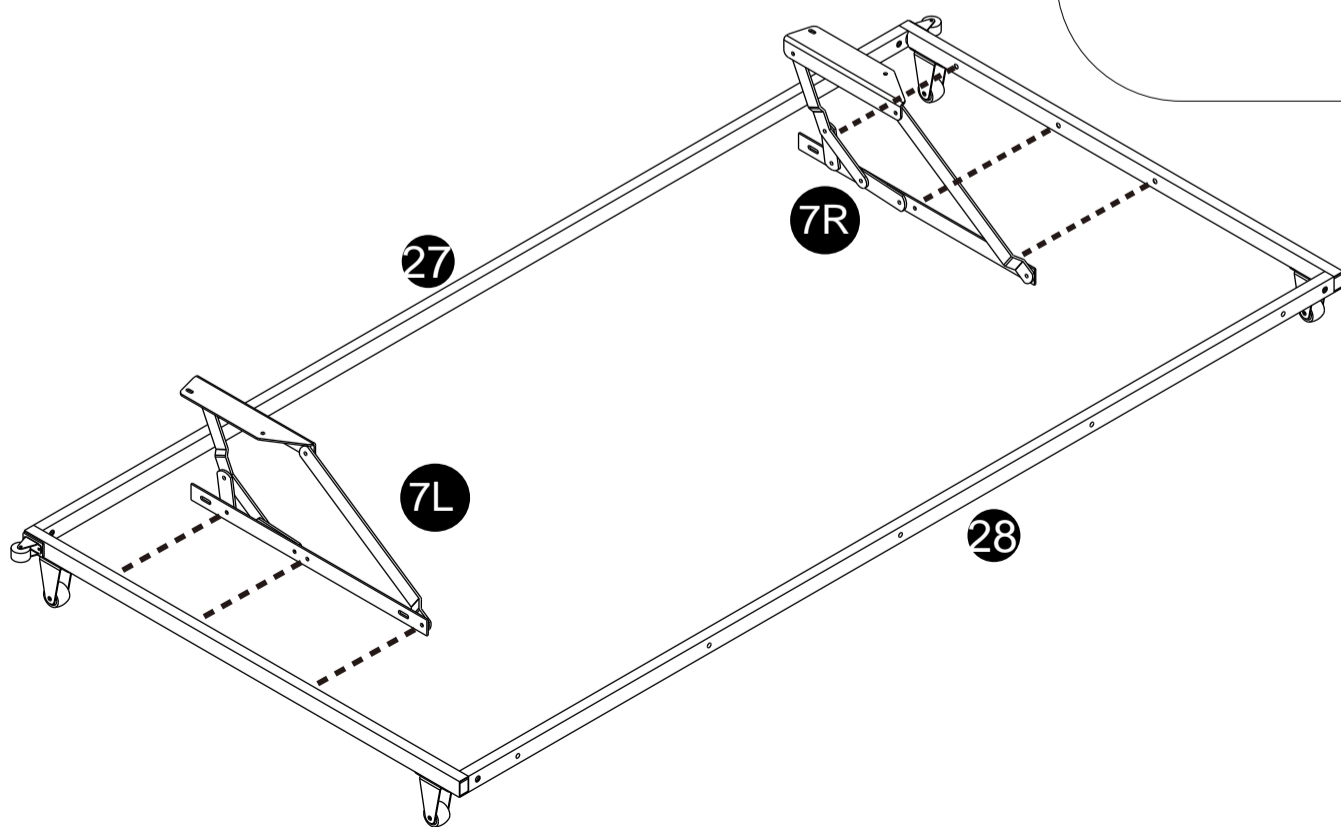

38

A x 1



K x 5



M6 x 30mm

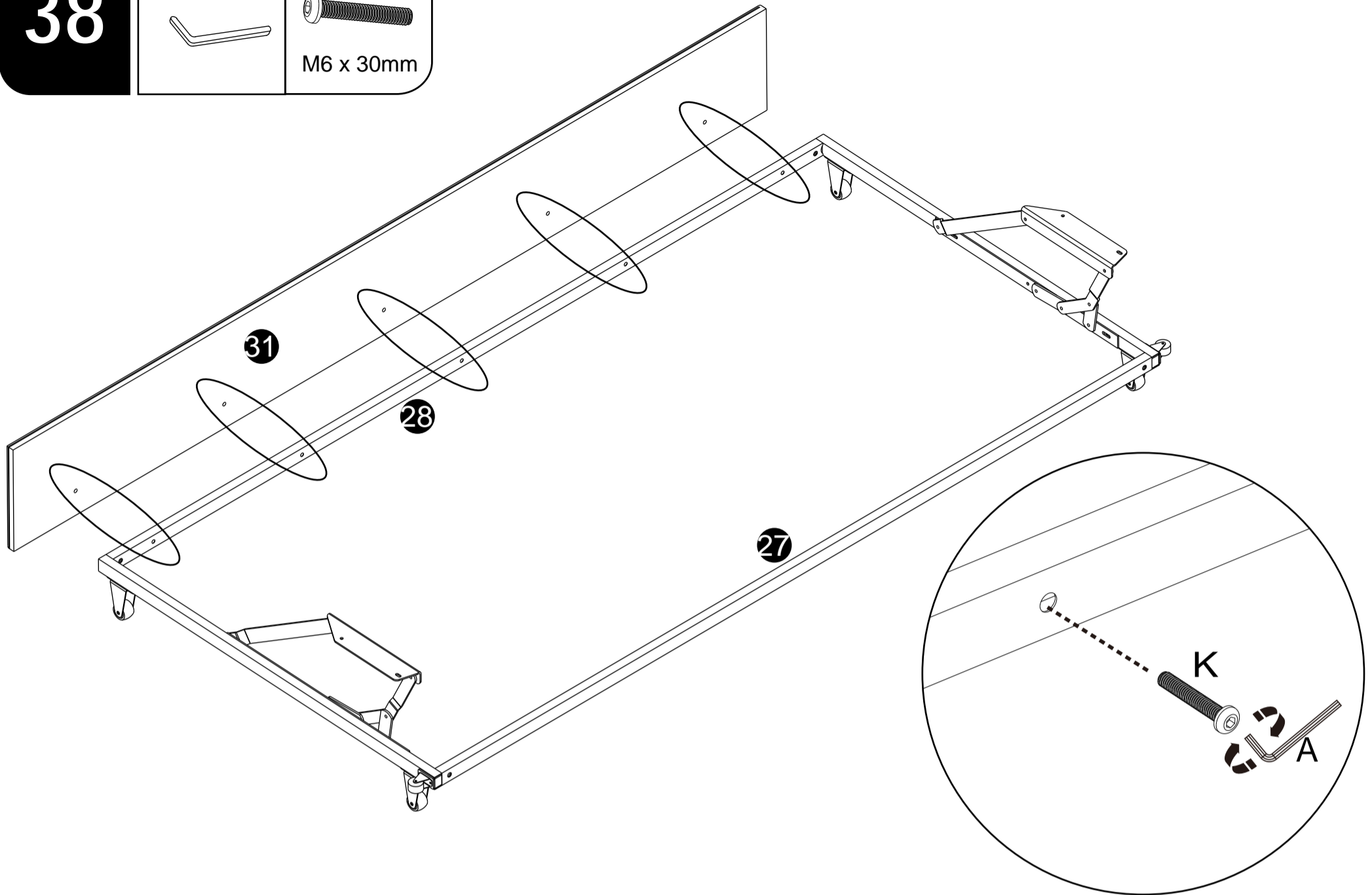

39

A x 1



H x 4



M8 x 30mm

P x 4

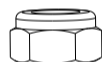

M8

Q x 4

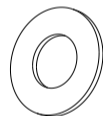

R x 1

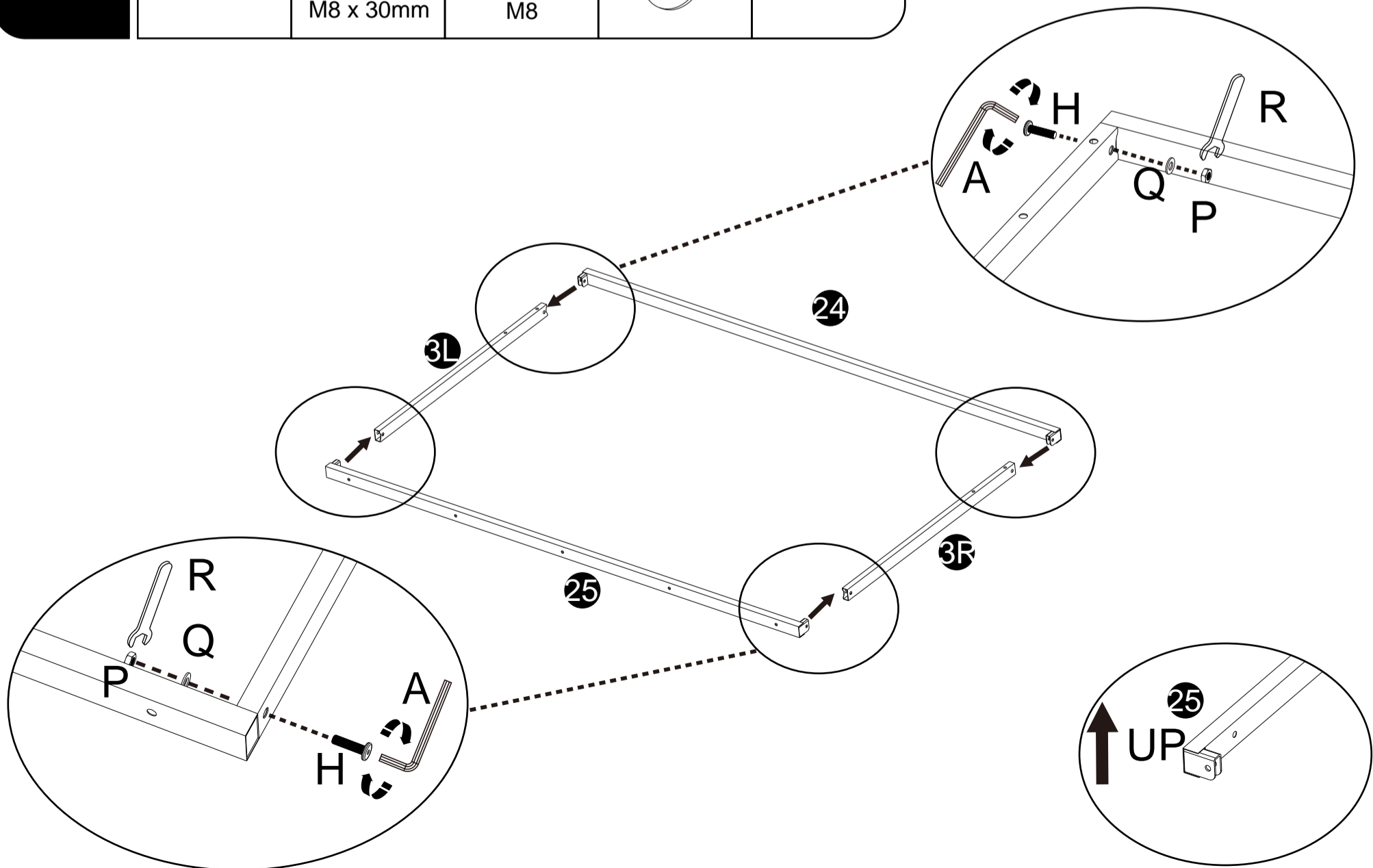

40

A x 1



L x 5



M6 x 35mm

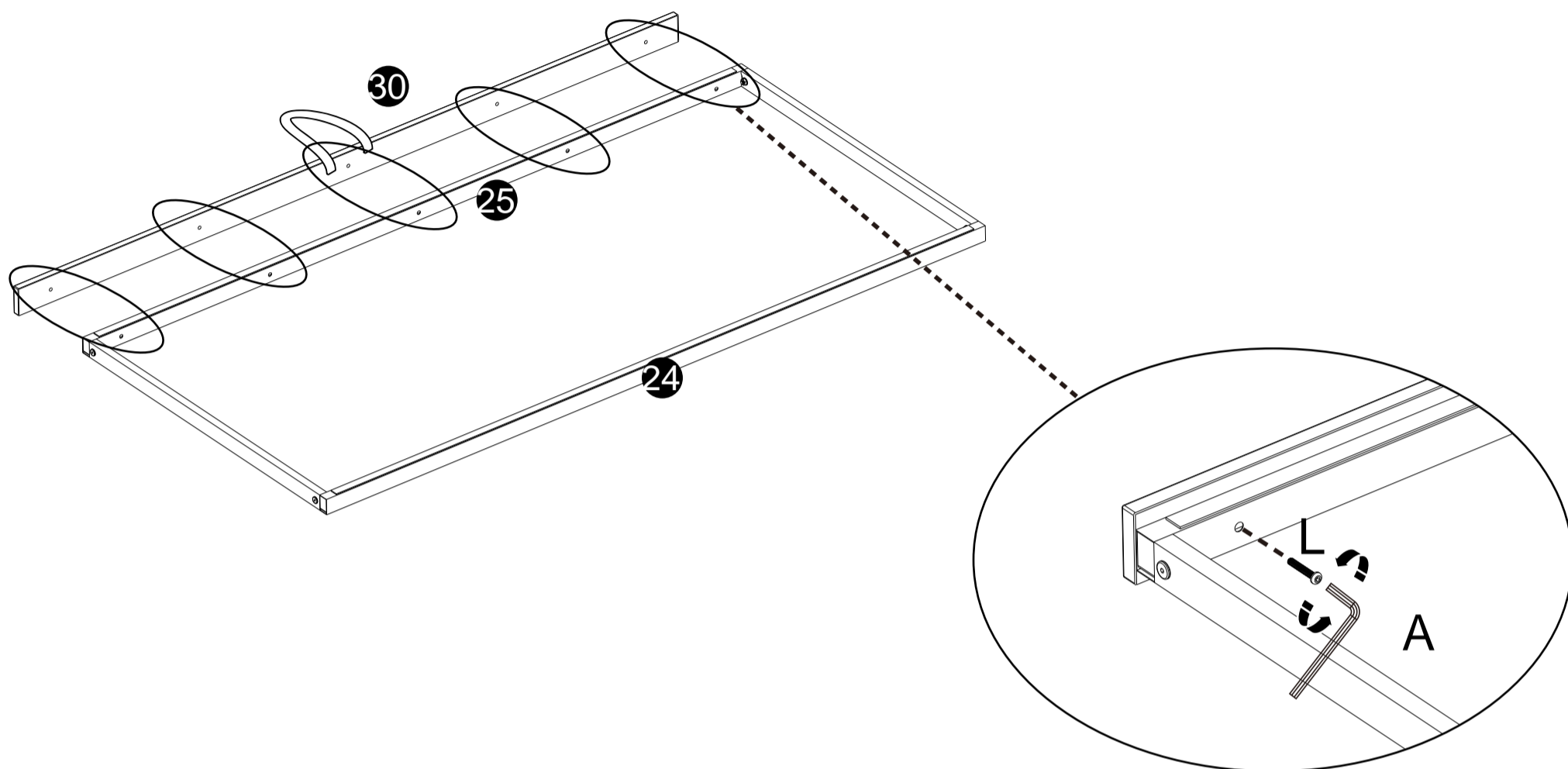

41

A x 1



E x 4



M6 x 16mm

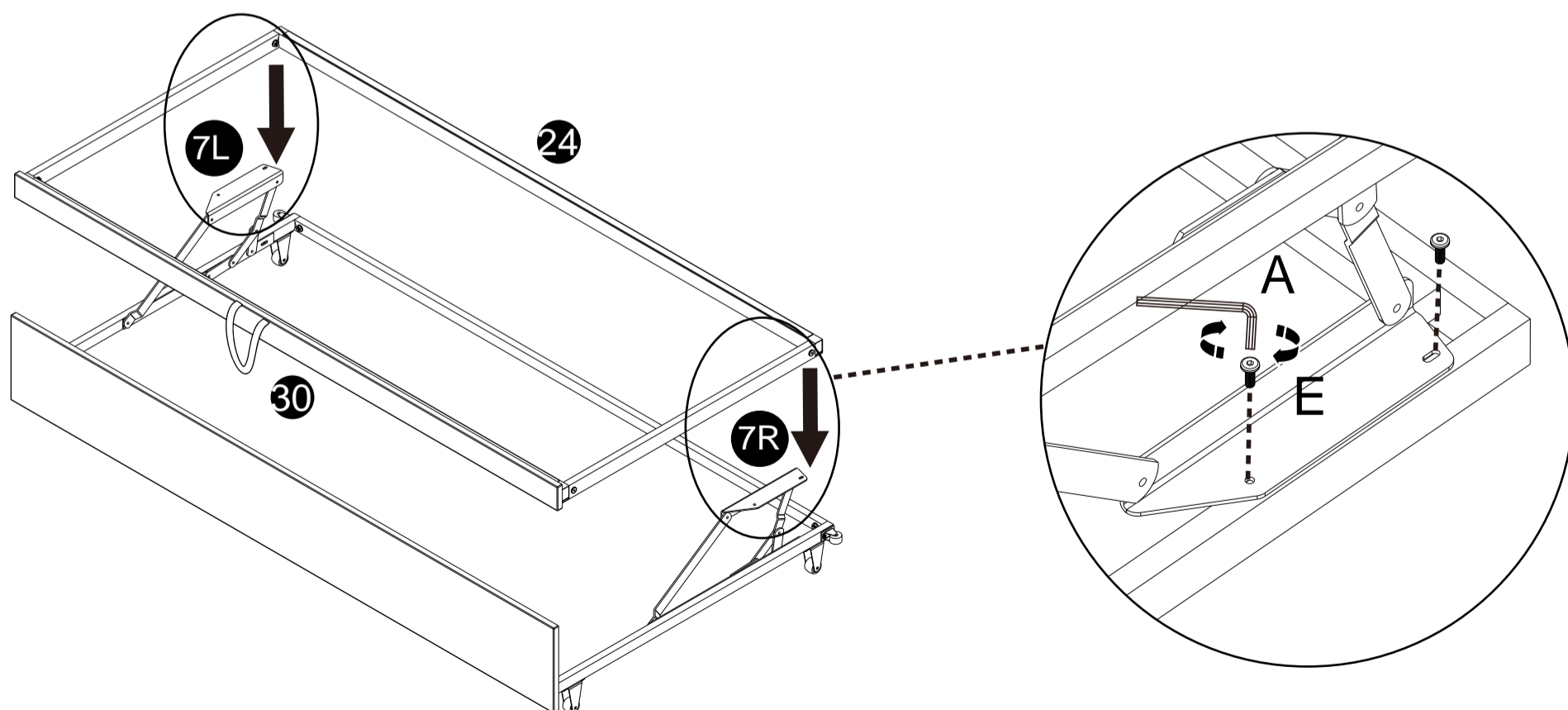

42

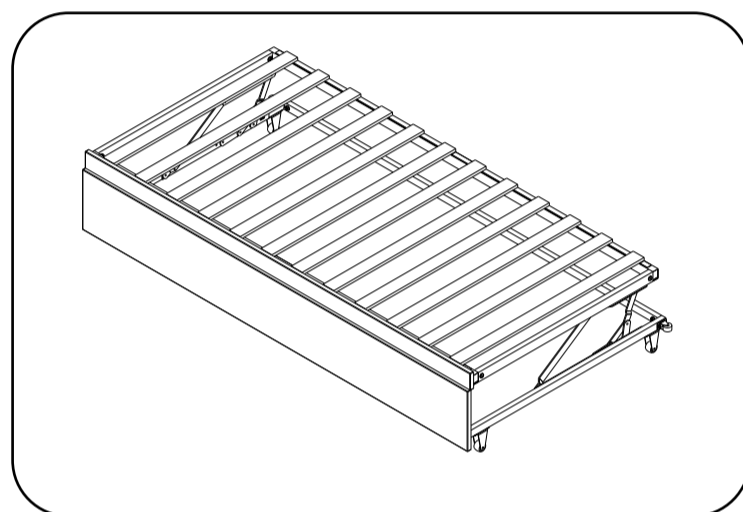
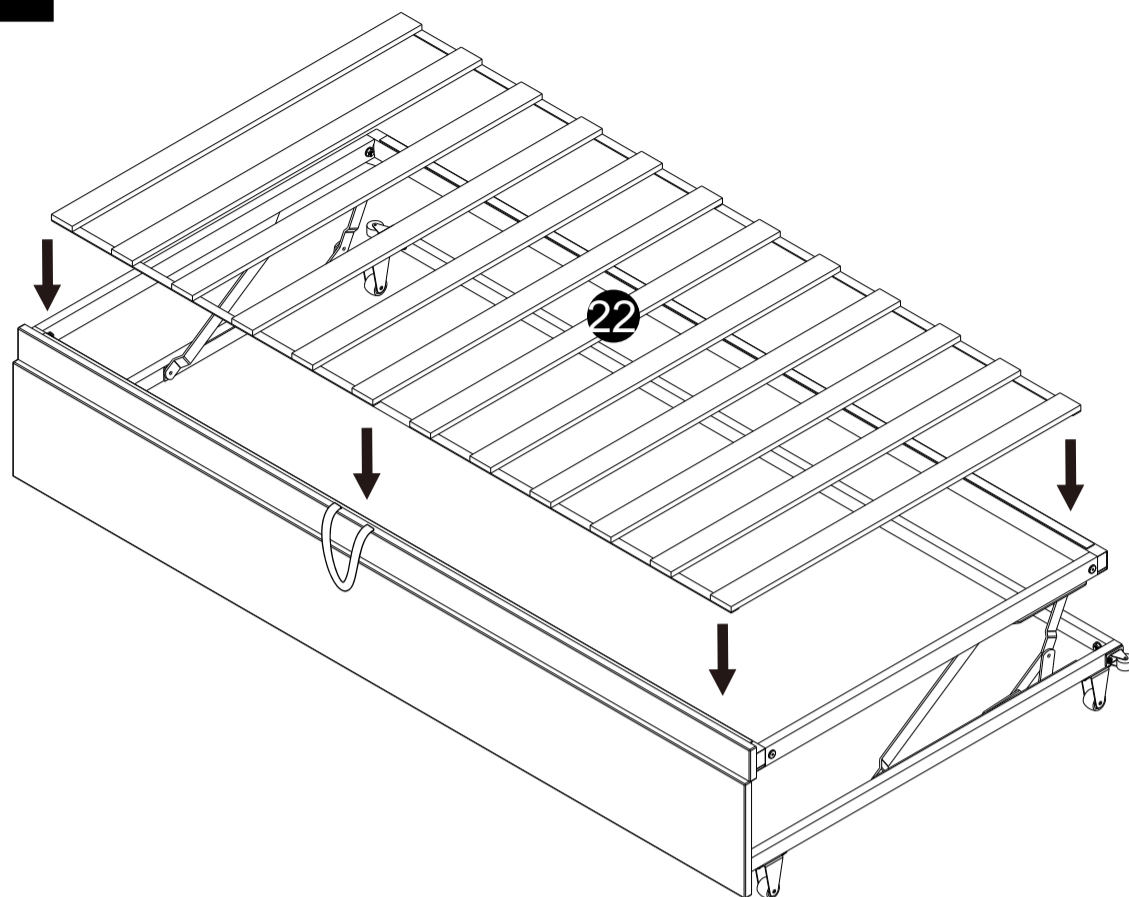

43

T x 1



X x 1



Y x 1

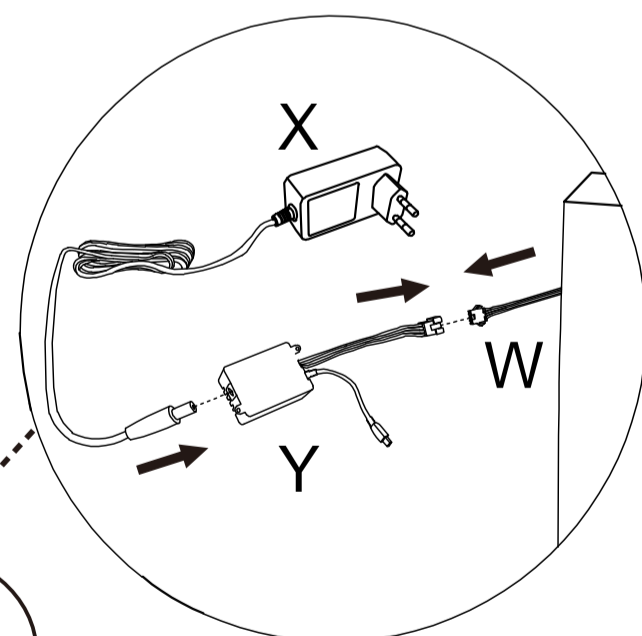
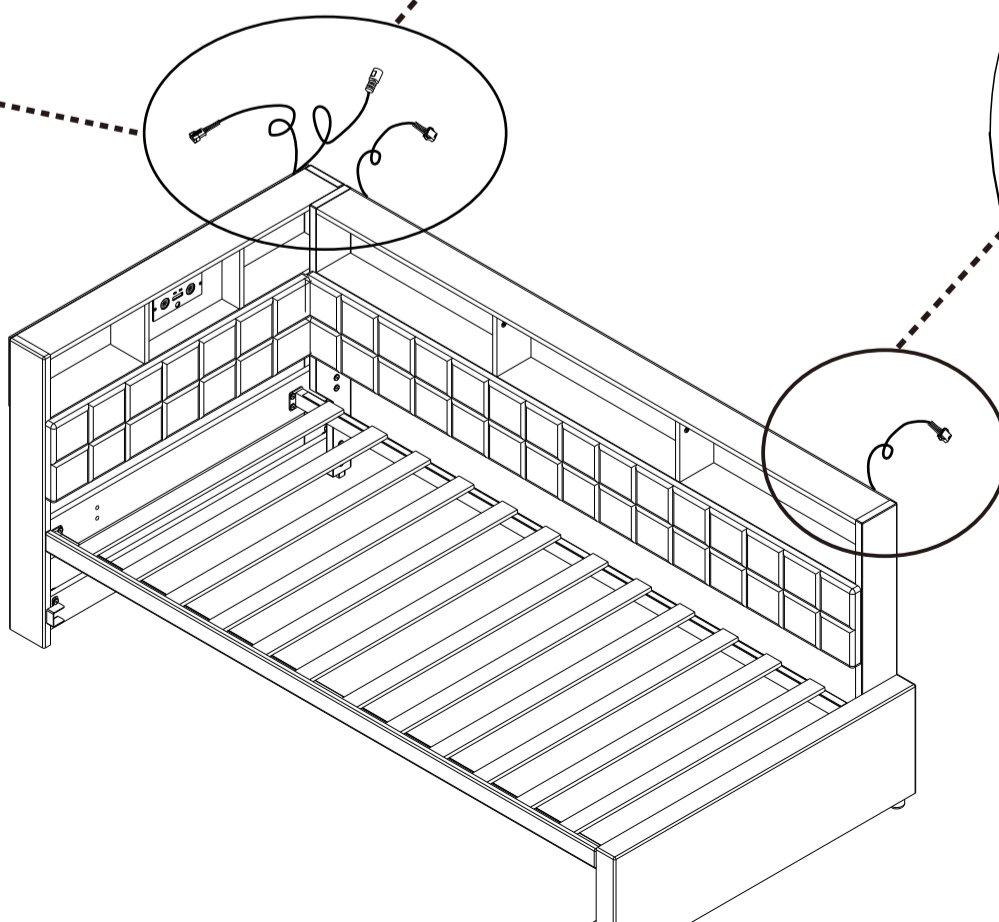
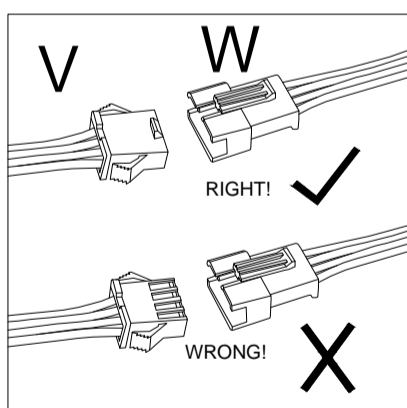
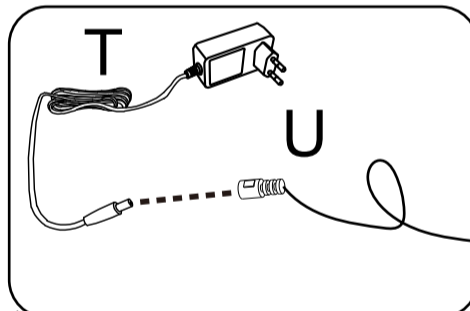

44

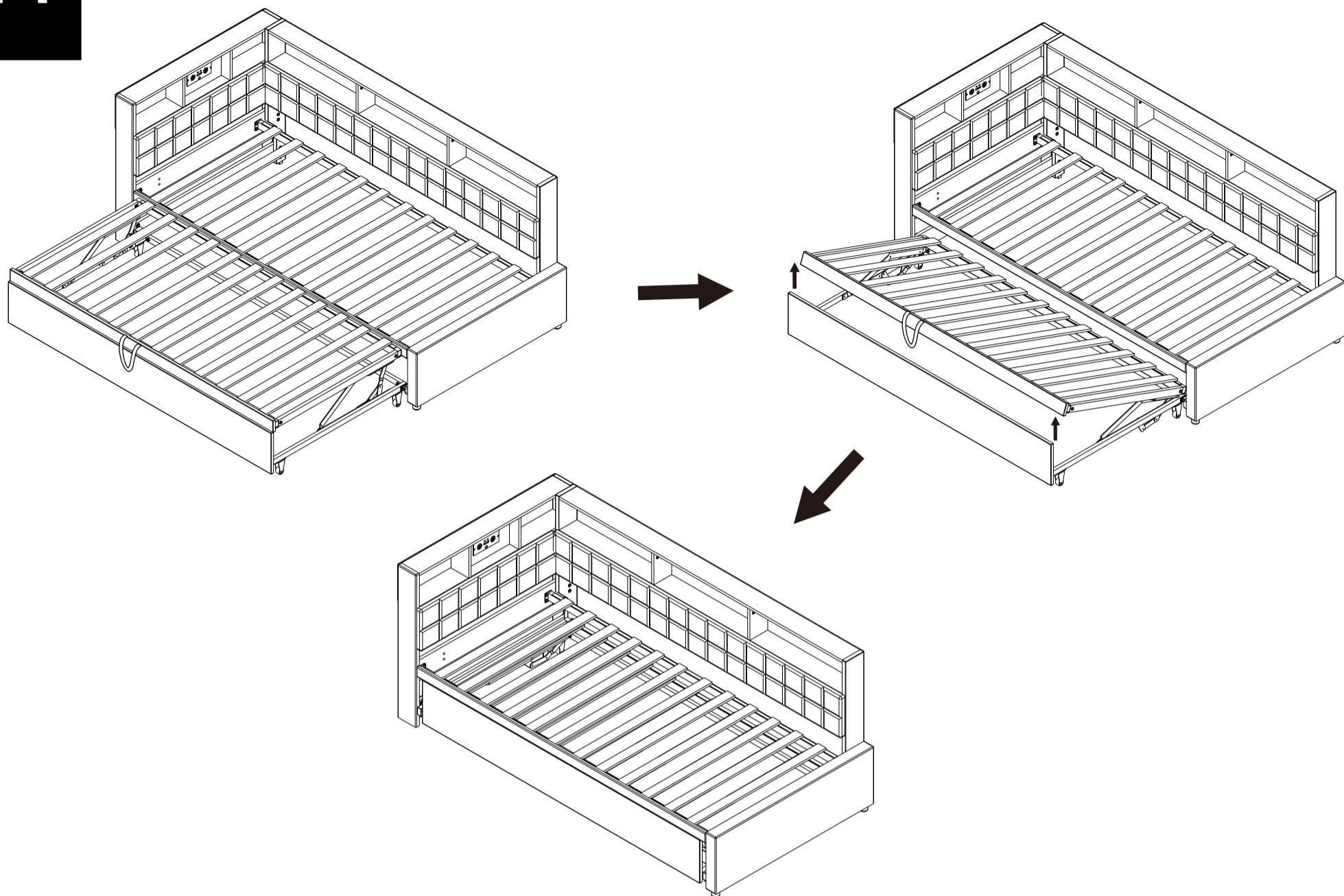

45

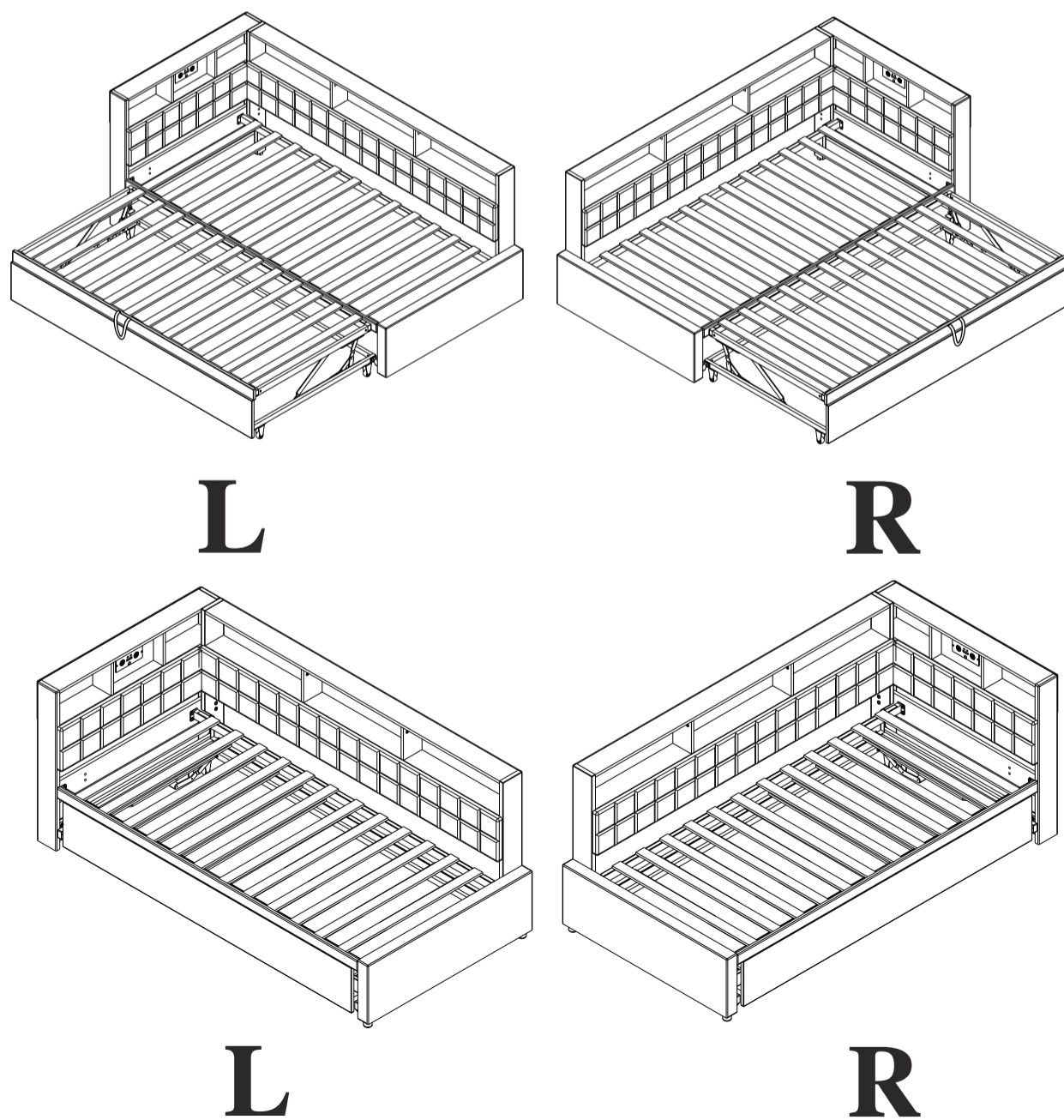

CERTIFICATE

ATTESTATION Certificate of Compliance

Technical file of the company mentioned below has been inspected and audit has been completed successfully.

The EMC Directive 2014/30/EU has been taken as references for these processes.

SHENZHEN BOYAXUAN TECHNOLOGY DEVELOPMENT CO., LTD.

3/F, 1st building, Xing Wei (Feng Huang), Third Industrial Area, Fuyong Street, Shenzhen, PEOPLE'S REPUBLIC OF CHINA

SHENZHEN BOYAXUAN TECHNOLOGY DEVELOPMENT CO., LTD.

3/F, 1st building, Xing Wei (Feng Huang), Third Industrial Area, Fuyong Street, Shenzhen, PEOPLE'S REPUBLIC OF CHINA

BYX3-0507200, BYX3-0507200E, BYX3-2522200, BYX3-2522200E
BYX3-XXXXYYZ("XXX" means 050-252, 3 digits number represents 10 times of the output voltage in volt in step of 0.1V. eg: 050=5.0Vdc, 252=25.2Vdc. "YYYY" means 0010-7200, 4 digits represent 100 times of output current value in A in step of 0.01A. eg: 0010=0.01A, 7200=7.2A; Z=E or Blank; E represents European plug; Blank represents Frame type

EN IEC 61000-3-2:2019
EN 61000-3-3:2013 + A1:2019

HK2011023168E
HK2011023168-1ER-R01



Certification Manager

The information of the certificate can be checked through www.cer-mark.com. The CE mark which is shown on the certificate can only be used under the conditions that the products complete with all of the relevant Directives of EC Declaration of Conformity. The Manufacturer should be responsible for the internal production control so that the products complied with the essential requirements of the above mentioned Directive(s). Certificate holder must notify all changes to the original certification laboratory of HUAK.



Testing Technology Co., Ltd.

Building B2, Junfeng Zhongcheng Zhizao Innovation Park, Heping, Fuhai Street, Bao'an District, Shenzhen, Guangdong, China
mark.com Postcode:518103 E-mail: service@cer-mark.com



Certificate of Conformity

Certificate Number: DL-250225010SC

Applicant: Shenzhen Blue The Light Technology co.,Ltd.
Floor 4, Building 2, Hongxing Industrial Park, Yuanling Village, Shiyan Town, Baoan District, Shenzhen

Manufacturer: Shenzhen Blue The Light Technology co.,Ltd.
Floor 4, Building 2, Hongxing Industrial Park, Yuanling Village, Shiyan Town, Baoan District, Shenzhen

Product: LED light strip

M/N: 5050CW/NW/WW/RGB/RGBW/RGBCW/IC-3/5/12/24-30-240L
2835CW/NW/WW/RGB/RGBW/RGBCW/IC-3/5/12/24-30-240L

Test Standard: EN IEC 60598-1:2021+ A11:2022
EN 60598-2-21:2015

The EUT described above has been tested by us with the listed standards and found in compliance with the council LVD directive 2014/35/EU. It is possible to use CE marking to demonstrate the compliance with this LVD Directive. It is only valid in connection with the test report number: DL-250225010SR.



Mar. 04, 2025

This certificate of conformity is based on a single evaluation of the submitted sample(s) of the above mentioned product. It does not imply an assessment of the whole product and relevant. Without the written approval, It is not permitted to use the test lab's logo.



Shenzhen DL Testing Technology Co., Ltd.
101-201, Comprehensive Building, Tongzhou Electronics Longgang Factory Area, No.1 Baolong Fifth Road, Baolong Community, Baolong Street, Longgang District, Shenzhen, China
Web: www.dl-cert.com E-mail: Service@dl-cert.com Tel: 400-688-3552



Certificate of Conformity

Certificate Number: DL-250225008SC

Applicant: Shenzhen Blue The Light Technology co.,Ltd.
Floor 4, Building 2, Hongxing Industrial Park, Yuanling Village, Shiyan Town, Baoan District, Shenzhen

Manufacturer: Shenzhen Blue The Light Technology co.,Ltd.
Floor 4, Building 2, Hongxing Industrial Park, Yuanling Village, Shiyan Town, Baoan District, Shenzhen

Product: LED strip infrared IR controller

M/N: LG-24-IR-12V, IR-17-24

Test Standard: EN 61347-2-13:2014+A1:2017
EN 61347-1:2015+A1:2021

The EUT described above has been tested by us with the listed standards and found in compliance with the council LVD directive 2014/35/EU. It is possible to use CE marking to demonstrate the compliance with this LVD Directive. It is only valid in connection with the test report number: DL-250225008SR.



Mar. 04, 2025

This certificate of conformity is based on a single evaluation of the submitted sample(s) of the above mentioned product. It does not imply an assessment of the whole product and relevant. Without the written approval, It is not permitted to use the test lab's logo.

Shenzhen DL Testing Technology Co., Ltd.
101-201, Comprehensive Building, Tongzhou Electronics Longgang Factory Area, No.1 Baolong Fifth Road, Baolong Community, Baolong Street, Longgang District, Shenzhen, China
Web: www.dl-cert.com E-mail: Service@dl-cert.com Tel: 400-688-3552



CERTIFICATE OF CONFORMITY

Low Voltage Directive 2014/35/EU

This Certificate of Conformity is hereby issued to the product designated below:

Certificate No......: 24SP01101L01
Report No......: SP2401101L01
Date Issue......: 2024-04-26
Applicant's name.....: Guangdong Sangu Technology Co., Ltd
Address.....: 402, Chuangye building, 8-28, Shaqi community Central Road, Xinqiao street, Bao'an District, Shenzhen.
Manufacturer's name.....: Guangdong Sangu Technology Co., Ltd
Address.....: 402, Chuangye building, 8-28, Shaqi community Central Road, Xinqiao street, Bao'an District, Shenzhen.
Product Description.....: POWER ADAPTER
Model(s)/Type References.....: SG-050yyyyz, GA-050yyyyz, GAT-050yyyyz, HZ-050yyyyz, SG-050yyyyAz, GA-050yyyyAz, GAT-050yyyyAz, HZ-050yyyyAz, SG-050yyyyAzC, GA-050yyyyAzC, GAT-050yyyyAzC, HZ-050yyyyAzC, SG-xxxxxyy12Az (xxx, yyyy, z are variables, see table A for details)
Parameters.....: Input: 100-240V~, 50/60Hz, 0.3A Max. (For models SG-050yyyyz, GA-050yyyyz, GAT-050yyyyz, HZ-050yyyyz, SG-050yyyyAz, GA-050yyyyAz, GAT-050yyyyAz, HZ-050yyyyAz, SG-050yyyyAzC, GA-050yyyyAzC, GAT-050yyyyAzC, HZ-050yyyyAzC)
Input: 100-240V~, 50/60Hz, 0.6A Max. (For models SG-xxxxxyy12Az)
Output: See table B for details
Standard(s).....: EN IEC 62368-1:2020/A11:2020

On the basis of the referenced test report(s), sample(s) tested of the above product have been found to comply with the standards harmonized with the directives listed on this verification at the time the tests were carried out. Other standards and Directives may be relevant to the product. This verification is part of the full test report(s) and should be read in conjunction with it(them).

Once compliance with all product relevant CE mark directives are verified, including any relevant e.g. risk assessment and production control, the manufacturer may indicate compliance by signing a Declaration of Conformity themselves and applying the mark to products identical to the tested sample(s)

Approved By

Eric Liu
Director of engineering department

Dongguan Pubiao Testing Technology Co., Ltd
No. 3, 1/F., Building A, No.30, Minghua Road, Juzhou, Shijie, Dongguan, Guangdong, China.
Tel: +86 769 81813516 E-mail: service@pubiaotest.com Web: www.pubiaotest.com

EN: Battery Safety Instructions

1. Do not dispose of used button batteries or remote controls in household trash. To protect the environment and prevent hazardous leakage, please follow these guidelines:
2. Remove button batteries after use and take them to a local battery recycling point or hazardous waste collection site.
3. Do not burn or dismantle the batteries to avoid explosion or toxic release.
4. If the remote control is no longer in use, please deliver it to a certified electronics recycling facility to promote resource reuse.
5. Keep out of reach of children to prevent accidental ingestion or injury.
6. This product does not include batteries; please purchase them separately. The compatible button cell model for the remote control is CR2025 3V
7. If the light strip is not working, please try replacing the battery first. If the issue persists, contact the seller for assistance.
8. **Keep the remote control away from children — keep it away from children!** If the battery is accidentally swallowed, seek medical attention immediately.

DE: Batteriesicherheitshinweise

1. Entsorgen Sie gebrauchte Knopfzellen oder Fernbedienungen nicht im Hausmüll. Um die Umwelt zu schützen und gefährliche Leckagen zu vermeiden, beachten Sie bitte die folgenden Hinweise:
2. Entfernen Sie die Knopfzelle nach dem Gebrauch und bringen Sie sie zu einer örtlichen Batteriesammelstelle oder einem Sondermüllentsorgungszentrum.
3. Batterien nicht verbrennen oder zerlegen, um Explosionen oder die Freisetzung giftiger Stoffe zu vermeiden.
4. Wenn die Fernbedienung nicht mehr verwendet wird, bringen Sie sie zu einer zertifizierten Elektronik-Recyclingstelle, um eine Wiederverwertung zu ermöglichen.
5. Außerhalb der Reichweite von Kindern aufbewahren, um versehentliches Verschlucken oder Verletzungen zu verhindern.
6. Dieses Produkt enthält keine Batterien. Bitte kaufen Sie diese separat. Das kompatible Knopfzellenmodell für die Fernbedienung ist CR2025 3V
7. Wenn der Lichtstreifen nicht funktioniert, versuchen Sie zunächst, die Batterie zu wechseln. Besteht das Problem weiterhin, kontaktieren Sie bitte den Verkäufer.
8. **Halten Sie die Fernbedienung unbedingt von Kindern fern — unbedingt fernhalten!** Wird die Batterie versehentlich verschluckt, suchen Sie sofort medizinische Hilfe auf.

FR:Instructions de sécurité pour les piles

1. Ne jetez pas les piles bouton usagées ou les télécommandes à la poubelle ménagère. Pour protéger l' environnement et éviter tout risque de fuite dangereuse, veuillez suivre les consignes suivantes :
2. Retirez les piles bouton après usage et déposez-les dans un point de collecte local ou un centre de déchets dangereux.
3. Ne brûlez pas et ne démontez pas les piles, cela pourrait entraîner une explosion ou libérer des substances toxiques.
4. Si la télécommande n'est plus utilisée, déposez-la dans un centre de recyclage agréé pour appareils électroniques, afin de favoriser la réutilisation des ressources.
5. Gardez hors de portée des enfants pour éviter tout risque d'ingestion accidentelle ou de blessure.
- 6.Ce produit ne contient pas de pile. Veuillez l'acheter séparément. Le modèle de pile bouton compatible pour la télécommande est CR2025 3V
- 7.Si le ruban LED ne fonctionne pas, essayez d'abord de remplacer la pile. Si le problème persiste, contactez le vendeur.
- 8.**Tenez la télécommande éloignée des enfants — éloignez-la vraiment !** En cas d'ingestion accidentelle de la pile, consultez immédiatement un médecin.



1



2



3



4



5



6



7



8



Modell : CR2025 3.V

9



10

