

# MONTAGEANLEITUNG

SKU: N623P377895 / N623P377896 / N623P377897 / N623P377898



FR

Cet appareil,  
ses cordons,  
et batterie  
se recyclent

À DÉPOSER  
EN MAGASIN



OU

À DÉPOSER  
EN DÉCHÈTERIE



Points de collecte sur [www.quefairedemesdechets.fr](http://www.quefairedemesdechets.fr)  
Privilégiez la réparation ou le don de votre appareil !

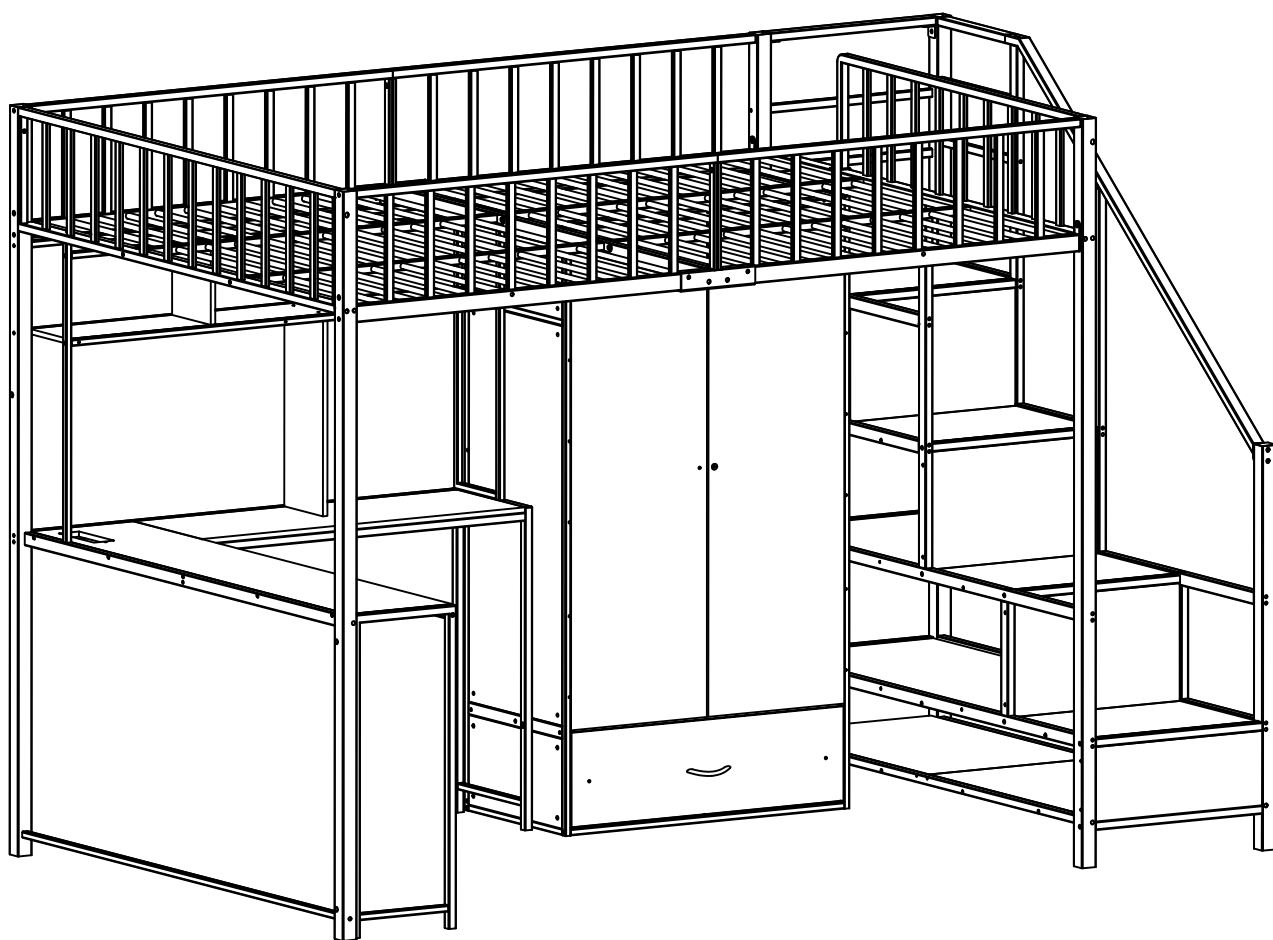

Dieses Set ist in 4 Boxen enthalten. Wenn Sie keine vollen 4 Boxen erhalten, wenden Sie sich bitte an unseren Kundenservice.

This set comes in 4 boxes. If you do not receive a full 4 boxes, please contact our customer service.

Hochbett 200x140cm

## ANLEITUNG

### WICHTIG - SORGFÄLTIG DURCHLESEN - FÜR ZUKÜNFTIGE REFERENZ BEWAHREN

- a) **WARNUNG** Hochbetten und das Oberbett von Etagenbetten sind wegen der Verletzungsgefahr durch Stürze nicht für Kinder unter sechs Jahren geeignet.
- b) **WARNUNG**-Etagenbetten und Hochbetten können ein ernstes Verletzungsrisiko darstellen, wenn sie nicht ordnungsgemäß verwendet werden. Befestigen oder hängen Sie niemals Gegenstände an einem Teil des Etagenbetts, die nicht für die Verwendung mit dem Bett vorgesehen sind, zum Beispiel Schnüre, Kordeln, Haken, Gurte und Taschen.
- c) **WARNUNG**-Kinder können zwischen Bett und Wand eingeklemmt werden.  
Um die Gefahr schwerer Verletzungen zu vermeiden, darf der Abstand zwischen der oberen Sicherheitsbarriere und der angrenzenden Konstruktion 75 mm nicht überschreiten oder mehr als 230 mm betragen.
- d) **WARNUNG**-Verwenden Sie das Etagenbett/Hochbett nicht, wenn ein Bauteil beschädigt ist oder fehlt. Ersatzteile werden zwischendurch beim Hersteller oder beim Händler angefordert.
- e) Befolgen Sie unbedingt die Installationsanweisungen und die Gebrauchsanweisung des Herstellers.
- f) Die empfohlene Größe der Matratze für das Bett beträgt 200 cm x 140 cm, maximale Dicke der Matratze: 10 cm.
- g) Es ist notwendig, den Raum zu lüften, um ein niedriges Feuchtigkeitsniveau aufrechtzuerhalten und das Wachstum von Schimmel im Bett und an dessen Peripherie zu verhindern.
- h) Verbindungselemente sollten immer richtig angezogen und regelmäßig überprüft werden. Bei Bedarf festziehen.

## INSTRUCTIONS

### IMPORTANT - READ CAREFULLY - RETAIN FOR FUTURE REFERENCE

- a) **WARNING**-High beds and the upper bed of bunk beds are not suitable for children under six years due to the risk of injury from falls;
- b) **WARNING**-Bunk beds and high beds can present a serious risk of injury from strangulation if not used correctly. Never attach or hang items to any part of the bunk bed that are not designed to be used with the bed, for example, but not limited to ropes, strings, cords, hooks, belts and bags.
- c) **WARNING**-Children can become trapped between the bed and the wall, a roof pitch, the ceiling adjoining pieces of furniture (e.g. cupboards) and the like. To avoid risk of serious injury the distance between the top safety barrier and the adjoining structure shall not exceed 75 mm or shall be more than 230 mm. d) **WARNING** - Do not use the bunk bed/high bed if any structural part is broken or missing; Replacement parts are between requested from the manufacturer or the store.
- e) it is imperative to always follow the installation instructions and manufacturer's use.
- f) The recommended size of the mattress to be used with the bed is 200cm x140cm, maximum thickness mattress: 10cm.
- g) It is necessary to ventilate the room in order to maintain a low level moisture and prevent mold growth in the bed and its periphery.
- h) Joining devices should always be tightened properly and regularly verified. Tighten if necessary.

## INSTRUCTIONS

### IMPORTANT - À LIRE ATTENTIVEMENT - CONSERVER POUR RÉFÉRENCE ULTÉRIEURE

- a) **AVERTISSEMENT** - Les lits surélevés et le lit supérieur des lits superposés ne conviennent pas aux enfants de moins de six ans en raison du risque de blessure dû à une chute;
- b) **AVERTISSEMENT** - Les lits superposés et les lits surélevés peuvent présenter un risque sérieux de blessure par strangulation s'ils ne sont pas utilisés correctement. Ne jamais attacher ou suspendre à des parties du lit superposé des objets qui ne sont pas conçus pour être utilisés avec le lit, par exemple, mais ne se limitant pas à des cordes, des ficelles, des cordes, des crochets, des ceintures et des sacs.
- c) **AVERTISSEMENT** - Les enfants peuvent rester coincés entre le lit et le mur, un toit incline les meubles adjacents au plafond (par exemple des armoires), etc. Pour éviter tout risque de blessure grave, la distance entre la barrière de sécurité supérieure et la structure adjacente ne doit pas dépasser 75 mm ou doit être supérieure à 230 mm.
- d) **AVERTISSEMENT** - N'utilisez pas le lit superposé/ le lit surélevé si une partie de la structure est cassée ou manquante. Les pièces de rechange sont demandées au fabricant ou au magasin.
- e) il est impératif de toujours suivre les instructions d'installation et l'utilisation du fabricant.
- f) La taille recommandée du matelas à utiliser avec le lit est 200 cm x 140 cm, épaisseur maximale du matelas: 10cm.
- g) Il est nécessaire de ventiler la pièce afin de maintenir un faible niveau d'humidité et d'empêcher la formation de moisissure dans le lit et à sa périphérie.
- h) Les dispositifs de jonction doivent toujours être correctement serrés et vérifiés régulièrement. Serrer si nécessaire.

## ISTRUZIONI

### IMPORTANTE - LEGGERE ATTENTAMENTE - CONSERVARE IL FUTURO RIFERIMENTO

- a) **ATTENZIONE** - I letti alti e il letto superiore a castello non sono adatti a bambini di età inferiore ai sei anni a causa del rischio di lesioni da cadute;
- b) **AVVERTENZA** - I letti a castello e i letti alti possono presentare un serio rischio di lesioni a causa di strangolamento se non utilizzati correttamente. Non attaccare o appendere mai oggetti a qualsiasi parte del letto a castello che non sono progettati per essere utilizzati con il letto, ad esempio, ma non limitato a corde, corde, corde, ganci, cinture e borse.
- c) **AVVERTENZA** - I bambini possono rimanere intrappolati tra il letto e la parete, un tetto inclinato il mobile adiacente al soffitto (ad es. armadi) e simili. Per evitare il rischio di gravi lesioni, la distanza tra la barriera di sicurezza superiore e a struttura adiacente non deve superare 75 mm o deve essere superiore a 230 mm.
- d) **ATTENZIONE** - Non utilizzare il letto a castello/letto alto se qualche parte strutturale è rotta o mancante; Le parti di ricambio sono tra quelle richieste al produttore o al negozio.
- e) è indispensabile seguire sempre le istruzioni di installazione e l'uso del produttore.
- f) Le dimensioni consigliate del materasso da utilizzare con il letto sono 200 cm x 140 cm, materasso di massimo spessore: 10 cm.
- g) È necessario ventilare l'ambiente per mantenere un'umidità bassa e prevenire la formazione di muffe nel letto e nella sua periferia.
- h) I dispositivi di giunzione devono essere sempre serrati correttamente e regolarmente verificati. Stringere se necessario.

## INSTRUCTIES

### BELANGRIJK - LEES AANDACHTIG - BEWAAR VOOR TOEKOMSTIGE REFERENTIE

- a) **WAARSCHUWING** Hoge bedden en het bovenste bed van stapelbedden zijn niet geschikt voor kinderen jonger dan zes jaar vanwege het risico op letsel door vallen;
- b) **WAARSCHUWING** Stapelbedden en hoge bedden kunnen een ernstig risico op verwonding vormen als ze niet correct worden gebruikt. Bevestig of hang nooit items aan een deel van het stapelbed die niet zijn ontworpen voor gebruik met het bed, bijvoorbeeld, maar niet beperkt tot touwen, koorden, koorden, haken, riemen en tassen.
- c) **WAARSCHUWING**-Kinderen kunnen vast komen te zitten tussen het bed en de muur, een dakhelling het plafond aangrenzende meubels (bijv. kasten) en dergelijke. Om het risico van ernstig letsel te voorkomen, mag de afstand tussen de bovenste veiligheidsbarrière en de aangrenzende structuur niet groter zijn dan 75 mm of meer dan 230 mm.
- d) **WAARSCHUWING**-Gebruik het stapelbed/hogbed niet als een structureel onderdeel kapot is of ontbreekt; Vervangende onderdelen worden tussen gevraagd door de fabrikant of de winkel.
- e) het is noodzakelijk om altijd de installatie-instructies en het gebruik van de fabrikant te volgen.
- f) De aanbevolen maat van de matras die met het bed wordt gebruikt, is 200 cm x 140 cm, maximale dikte matras: 10cm.
- g) Het is noodzakelijk om de kamer te ventileren om een laag vochtgehalte te handhaven en schimmelgroei in het bed en de periferie ervan te voorkomen. h) Verbindingsinrichtingen moeten altijd goed worden vastgedraaid en regelmatig worden gecontroleerd. Draai indien nodig vast.

## IISTRUKCJE

### WAŽNE - PRZECZYTAJ UWAGNIE - ZACHOWAJ NAPRZYSZŁOŚĆ

- a) **OSTRZEŻENIE** Wysokie łózka i górne łózko łózek piętrowych nie są odpowiednie dla dzieci poniżej sześciu lat ze względu na ryzyko obrażeń w wyniku upadku;
- b) **OSTRZEŻENIE** - Łózka piętrowe i wysokie łózka mogą stwarzać poważne ryzyko obrażeń na skutek uduszenia, jeśli nie zostaną właściwie użyte. Nigdy nie mocuj ani nie wieszaj przedmiotów na żadnej części łózka piętrowego, które nie są przeznaczone do użytku z łóżkiem, na przykład, ale nie ograniczając się do lin, sznurków, sznurków, haczyków, pasów i toreb.
- c) nachyleniem dachu pod sufitem przylegającymi meblami (np. szafkami) i tym podobne. Aby uniknąć ryzyka poważnych obrażeń, odległość między górną barierą bezpieczeństwa a przylegającą konstrukcją nie może przekraczać 75 mm lub być większą niż 230 mm. **OSTRZEŻENIE** - Dzieci mogą zostać uwięzione między łóżkiem a ścianą.
- d) **OSTRZEŻENIE** - Nie używaj łózka piętrowego/wysokiego łózka, jeśli jakkolwiek część konstrukcyjna jest zepsuta lub brakuje jej; Części zamienne są wymagane od producenta lub sklepu.
- e) bezwzględnie należy przestrzegać instrukcji instalacji i użytkowania producenta.
- f) Zalecany rozmiar materaca do zastosowania z łóżkiem to 200 cm x 140 cm, maksymalna grubość materaca: 10cm.
- g) Konieczna jest wentylacja pomieszczenia w celu utrzymania niskiego poziomu wilgoci i zapobiegania rozwojowi pleśni w łózku i jego obrzeżach.
- h) Urządzenia łączące powinny być zawsze odpowiednio dokręcone i regularnie sprawdzane. Dokręć w razie potrzeby.

## INSTRUKCE

### DŮLEŽITÉ PŘEČTĚTE SI POZORNĚ - UCHOVÁVAJTE PRO BUDOUCÍ REFERENCE

- a) **VAROVÁNÍ**-vysoké postele a horní lůžka palandy nejsou vhodné pro děti do šesti let z důvodu rizika zranění pádem;
- b) **VAROVÁNÍ**-Patrové postele a vysoké postele mohou představovat vážné riziko zranění při uškrcení, pokud nebudou správně použity. Nikdy nepřipevňujte ani nezavěšujte předměty na žádnou část palandy, které nejsou navrženy pro použití s postelí, ale neomezuji se pouze na lana, provázky, šňůry, háčky, pásy a tašky c) **VÝSTRAHA** - Děti se mohou zachytit mezi postel a zed, sklonit střechu stropy přilehlé kusy nábytku (např. skříně) a podobně. Aby se zabránilo riziku vážného zranění, nesmí vzdálenost mezi horní bezpečnostní bariérou a sousední konstrukcí překročit 75 mm nebo být větší než 230 mm.
- d) **VÝSTRAHA**-Nepoužívejte patrové lůžko / vysoké lůžko, pokud je některá konstrukční část zlomená nebo chybí. Náhradní díly jsou mezi na vyžádání od výrobce nebo obchodu.
- e) je bezpodmínečně nutné dodržovat instalační pokyny a použití výrobcem.
- f) Doporučená velikost matrace pro použití s postelí je 200 cm x 140 cm, maximální tloušťka matrace: 10 cm.
- g) Místnost je nutné ventilovat, aby se udržela nízká hladina vlhkosti a zabránilo se růstu plísní v loži a jeho obvodu..
- h) Spojovací zařízení by měla být vždy pevně dotažena a pravidelně ověřována, V h případě potřeby dotáhněte.

## INŠTRUKCIE

### DÔLEŽITÉ - POZORNE SI PREČÍTAJTE - UCHOVÁVAJTE PRE BUDÚCE REFERENCIE

- a) **VÝSTRAHA**-Vysoké postele a horné postele poschodových postelí nie sú vhodné pre deti do šiestich rokov kvôli riziku zranenia pádom;
- b) **VÝSTRAHA**-poschodové postele a vysoké postele môžu predstavovať vážne riziko zranenia priškrcením, ak sa nebudú správne používať. Nikdy nepřipevňujte ani nevesajte predmety k žiadnej časti poschodovej postele, ktorá nie je určená na použitie s postelou, napríklad, ale nielen, laná, šnúry, šnúry, háčiky, pásy a tašky,
- c) **VÝSTRAHA**-Deti sa môžu zachytiť medzi postelou a stenou, sklonom strechy, stropom priliehajúcim kusy nábytku (napr. skrinky) a podobne. Aby sa predišlo riziku vážneho zranenia, vzdialenosť medzi hornou bezpečnostnou bariérou a príľahlou konštrukciou nesmie prekročiť 75 mm alebo byť viac ako 230 mm.
- d) **VÝSTRAHA**-Nepoužívajte poschodovú postel/vysoké lóžko, ak je akákoľvek konštrukčná časť poškodená alebo chýba: Náhradné diely sú potrebné na vyžiadanie od výrobcu alebo skladu.
- e) je bezpodmínečne nutné postupovať podľa pokynov na inštaláciu a podľa pokynov výrobcu.
- f) Odporúčaná veľkosť matrace použitého na lóžko je 200 cm x 140 cm, maximálna hrúbka matrace: 10 cm.
- g) Miestnosť je potrebné vetrať, aby sa udržala nízka úroveň vlhkosti a zabránilo sa rastu plesní v lóžku a jeho obvode.
- ) Spojovacie zariadenia by sa mali vždy pevne dotiahnuť a pravidelne preverovať. V prípade potreby dotiahnite.

## UTASÍTÁS

### FONTOS - OLVASSA EL FIGYELMESEN - VÁRJON A JÖVŐBEN

- a) VIGYÁZAT A magas ágyak és az emeletes ágyak felső ágya nem alkalmas hat év alatti gyermekek számára az esések sérülésének veszélye miatt ;
- b) FIGYELMEZTETÉS - Az emeletes ágyak és a magas ágyak súlyos sérülést okozhatnak a főtogatás következtében, ha nem használják helyesen. Soha ne csatlakoztasson és ne lógjon az emeletes ágy olyan részeire, amelyeket például nem az ágyhoz való felhasználásra terveztek, de ezekre nem korlátozódnak: kötelek, húrok, zsinórok, horgok, övek és táskák.
- c) FIGYELMEZTETÉS - A gyermekek becsapódhatnak az ágy és a fal közé, tetőtéri a mennyezetet a szomszédos bútorokhoz (például szekrényekhez) és hasonlókhoz. A súlyos sérülés kockázatának elkerülése érdekében a felső biztonsági akadály és a szomszédos szerkezet közötti távolság nem haladhatja meg a 75 mm-t vagy több, mint 230 mm.
- d) FIGYELMEZTETÉS Ne használja az emeletes ágyat/magas ágyat, ha valamelyik szerkezeti elem törött vagy hiányzik; A cserealkatrészeket a gyártótól vagy a bolttól kérheti.
- e) feltétlenül kövesse a telepítési utasításokat és a gyártó általi felhasználást. Az ágyhoz használni kívánt matrac ajánlott mérete 200 cm x 140 cm, a matrac maximális vastagsága: 10 cm.
- g) Szellőztetni kell a helyiséget, hogy fennmaradjon az alacsony nedvességtartalom, és megakadályozzák a penész növekedését az ágyban és annak peremén.
- h) A csatlakozóberendezéseket mindig megfelelően meg kell hűzni és rendszeresen ellenőrizni kell. Szükség esetén húzza meg.

## TALÍMATLAR

### ÖNEMLİ - DİKKATLE OKUYUN - GELECEK REFERANS İCİN TUTUN

- a) UYARI Yüksek yataklar ve ranzaların üst yatağı, düşme nedeniyle yaralanma tehlikesi nedeniyle altı yaşın altındaki çocuklar için uygun değildir,
- b) UYARI- Ranzalar ve yüksek yataklar, doğru kullanılmadığı takdirde boğulma nedeniyle ciddi yaralanma riski oluşturabilir. Hiçbir zaman ranza yatağının, yatakla birlikte kullanılmak üzere tasarlanmamış, ancak ipler, ipler, kordonlar, kancalar, kayışlar ve çantalar ile sınırlı olmamak üzere herhangi bir parçasına takmayın veya asılmayın.
- c) UYARI-Çocuklar yatakla duvar arasında sıkışıp kalabilir, tavana bitişik mobilya parçaları (örneğin dolaplar) ve benzeri bir tavan döşenir. Ciddi yaralanma riskini önlemek için üst güvenlik bariyeri ve bitişik yapı arasındaki mesafe 75 mm'yi geçmemelidir veya 230 mm'den fazla olmalıdır,
- d) UYARI-Herhangi bir yapısal parça kırılmış veya eksikse ranza/yüksek yatak kullanmayın; Yedek parçalar üretici veya mağazadan talep arasındadır. e) her zaman kurulum talimatlarını ve üreticinin kullanımını takip etmek zorunludur.
- f) Yatak ile birlikte kullanılması tavsiye edilen yatak boyutu 200 cm x 140 cm, maksimum kalınlık yatağı: 10 cm'dir.
- g) Düşük seviyede nem sağlamak ve yatak ve çevresinde küf oluşumunu önlemek için odanın havalandırılması gerekir.
- h) Birleştirme cihazları her zaman uygun şekilde sıkılmalı ve düzenli olarak kontrol edilmelidir. Gerekirse sıkın.

## INSTRUCȚIUNI

### IMPORTANT - CITITI CU ATENȚIE - PATITI PENTRU REFERINȚĂ VIITORĂ

- a) AVERTIZARE Paturile înalte și patul superior al paturilor nu sunt potrivite
- b) AVERTIZARE - Paturile suprapuse și paturile înalte pot prezenta un risc grav de rănire din cauza strangularii dacă nu sunt utilizate corect. Nu atașați și nu agățați niciodată articole pe nicio parte a patului care nu sunt concepute pentru a fi utilizate cu patul, de exemplu, dar fără a se limita la frânghii, corzi, snururi, cârlige, curele și saci.
- c) AVERTIZARE Copiii pot deveni prinși între pat și perete, pot acoperi acoperișul pe piesele de mobilier alăturate (de ex. dulapuri) și altele asemenea. Pentru a evita riscul de rănire gravă, distanța dintre bariera de siguranță superioară și structura alăturată nu trebuie să depășească 75 mm sau să fie mai mare de 230 mm.
- d) AVERTIZARE - Nu folosiți patul supraetajat /patul înalt dacă o parte structurală este ruptă sau lipsește; Piesele de schimb se fac între solicitarea producătorului sau a magazinului.
- e) este obligatoriu să respectați întotdeauna instrucțiunile de instalare și utilizarea producătorului.
- f) Dimensiunea recomandată a saltelei care va fi folosită cu patul este de 200cm x140cm, grosimea maximă a saltelei: 10 cm.
- g) Este necesară ventilarea camerei pentru a menține o umiditate la nivel scăzut și a preveni creșterea mucegaiului în pat și la periferia acestuia.
- h) Dispozitivele de îmbinare trebuie întinse întotdeauna corect și verificate regulat. Strângeți dacă este necesar,

## ИНСТРУКЦИИ

### ВАЖНО ПРОЧИТАЙТЕ ВНИМАТЕЛЬНО - СОХРАНИТЕ БУДУЩУЮ ССЫЛКУ

- a) ПРЕДУПРЕЖДЕНИЕ Высокие кровати и верхняя кровать двухъярусных кроватей не подходит для детей младше шести из-за риска получения травмы в результате падения;
- b) ПРЕДУПРЕЖДЕНИЕ двухъярусные кровати и высокие кровати могут представлять серьезную опасность травмирования от удушья, неправильно использовать. Никогда не прикрепляйте и не подвешивайте предметы к какой-либо части двухъярусной кровати, например, которые не предназначены для использования с кроватью, но не ограничиваются веревками, веревками, шнурами, крючками, ремнями и сумками.
- c) ПРЕДУПРЕЖДЕНИЕ Дети могут оказаться в ловушке между кроватью и стеной, крышей, наклонить потолок к смежным предметам мебели (например, шкафам) и т.п. Во избежание риска получения серьезных травм расстояние между верхним защитным барьером и прилегающей конструкцией не должно превышать 75 мм или должно быть более 230 мм.
- d) ПРЕДУПРЕЖДЕНИЕ не используйте двухъярусную кровать / высокую кровать, если какая-либо конструктивная часть сломана или отсутствует; Запасные части между запросами от производителя или магазина. e) обязательно всегда следовать инструкциям по установке и использованию изготовителем.
- e) Рекомендуются размер матраса, который будет использоваться с кроватью, составляет 200 см x 140 см, максимальная толщина матраса: 10
- f) Необходимо проветривать помещение, чтобы поддерживать низкий уровень влаги и предотвращать образование плесени в ложе и на его периферии.
- g) Соединительные устройства всегда должны быть надежно затянуты и регулярно проверяться. Затянуть при необходимости.

## English

IMPORTANT ! KEEP FOR FUTURE REFERENCE: READ CAREFULLY

- To be assembled by an adult. Assembly must be checked by an adult before use
- WARNING | Keep all screws, small parts and plastic bags out of the reach of children
- Properly identify all parts before assembling
- Never use your item if any of its parts are broken or missing
- Should any problems arise, please contact our After Sales Service
- Manufacturer's instructions shall be followed at all times
- Care: Clean with a soft, dry cloth. In case of larger stains, carefully rub with a slightly damp, non- abrasive sponge
- Avoid the risk of fire by not placing furniture near sources of ignition or hot items
- Do not jump on the bed

## Deutsch

WICHTIG ! ZUM SPÄTEREN NACHSCHLAGEN AUFBEWAHREN: SORGFÄLTIG LESEN

- Muss von einem Erwachsenen zusammengebaut werden. Der Zusammenbau muss vor dem Gebrauch von einem Erwachsenen überprüft werden
- WARNUNG! Bewahren Sie alle Schrauben, Kleinteile und Plastikbeutel außerhalb der Reichweite von Kindern auf
- Kennzeichnen Sie vor dem Zusammenbau alle Teile richtig
- Benutzen Sie Ihren Artikel niemals, wenn Teile gebrochen sind oder fehlen
- Sollten Probleme auftreten, wenden Sie sich bitte an unseren Kundendienst
- Die Anweisungen des Herstellers sind stets zu befolgen
- Pflege: Mit einem weichen, trockenen Tuch reinigen. Bei größeren Flecken vorsichtig mit einem leicht feuchten, nicht scheuernden Schwamm abreiben, nicht scheuernden Schwamm Vermeiden Sie die Gefahr eines Brandes, indem Sie die Möbel nicht in der Nähe von Zündquellen oder heißen Gegenständen aufstellen
- Nicht auf das Bett springen

## Français

IMPORTANT ! CONSERVER POUR RÉFÉRENCE ULTÉRIEURE: LIRE ATTENTIVEMENT

- Le montage doit être effectué par un adulte. Le montage doit être vérifié par un adulte avant Utilisation
- ATTENTION! Tenir les vis, les petites pièces et les sachets en plastique hors de portée des enfants Identifiez correctement toutes les pièces avant de les assembler
- N'utilisez jamais votre article si l'une de ses pièces est cassée ou manquante
- En cas de problème, veuillez contacter notre service après-vente
- Les instructions du fabricant doivent être respectées à tout moment
- Entretien: nettoyer avec un chiffon doux et sec. En cas de taches plus importantes, frotter soigneusement avec une éponge non abrasive légèrement humide, légèrement humide et non Abrasive
- Évitez les risques d'incendie en ne plaçant pas les meubles à proximité de sources d'inflammation ou d'objets chauds
- Ne pas sauter sur le lit

## Italiano | IMPORTANTE ! CONSERVARE PER RIFERIMENTO FUTURO: LEGGERE ATTENTAMENTE

- Deve essere assemblato da un adulto. L'assemblaggio deve essere controllato da un adulto prima dell'uso
- IMPORTANTE! CONSERVARE PER RIFERIMENTO FUTURO: LEGGERE ATTENTAMENTE**
- **ATTENZIONE!** Tenere tutte le viti, le piccole parti e i sacchetti di plastica fuori dalla portata dei bambini
  - Identificare correttamente tutte le parti prima dell'assemblaggio
  - Non utilizzare mai l'articolo se alcune parti sono rotte o mancanti
  - In caso di problemi, si prega di contattare il nostro Servizio Post Vendita
  - Le istruzioni del produttore devono essere sempre seguite
- Cura: Pulire con un panno morbido e asciutto. In caso di macchie più estese, strofinare accuratamente con una spugna leggermente umida e nonspugna leggermente umida e non abrasiva
- Evitare il rischio di incendio, non collocando i mobili vicino a fonti di accensione o a oggetti caldi
  - Non saltare sul letto

## Español | IMPORTANTE ! CONSERVELO PARA FUTURAS CONSULTAS: LEA ATENTAMENTE

- Debe ser montado por un adulto. El montaje debe ser comprobado por un adulto antes del uso
- ADVERTENCIA** Mantenga todos los tornillos, piezas pequeñas y bolsas de plástico fuera del alcance de los niños.
- Identifique correctamente todas las piezas antes de montarlas
  - Nunca utilice su artículo si alguna de sus piezas está rota o falta
  - Si surge algún problema, póngase en contacto con nuestro Servicio Postventa
  - Las instrucciones del fabricante deben seguirse en todo momento
  - Cuidado: Limpiar con un paño suave y seco. En caso de manchas más grandes, frote cuidadosamente con una esponja no abrasiva ligeramente humedecida.
  - Evite el riesgo de incendio no colocando los muebles cerca de fuentes de ignición u objetos calientes.
  - No saltar sobre la cama.



# MONTAGEANLEITUNG

SKU:N623P377895 / N623P377896 /N623P377897 /N623P377898

## DETAIL VIEW ( DETAIL ANSICHT )

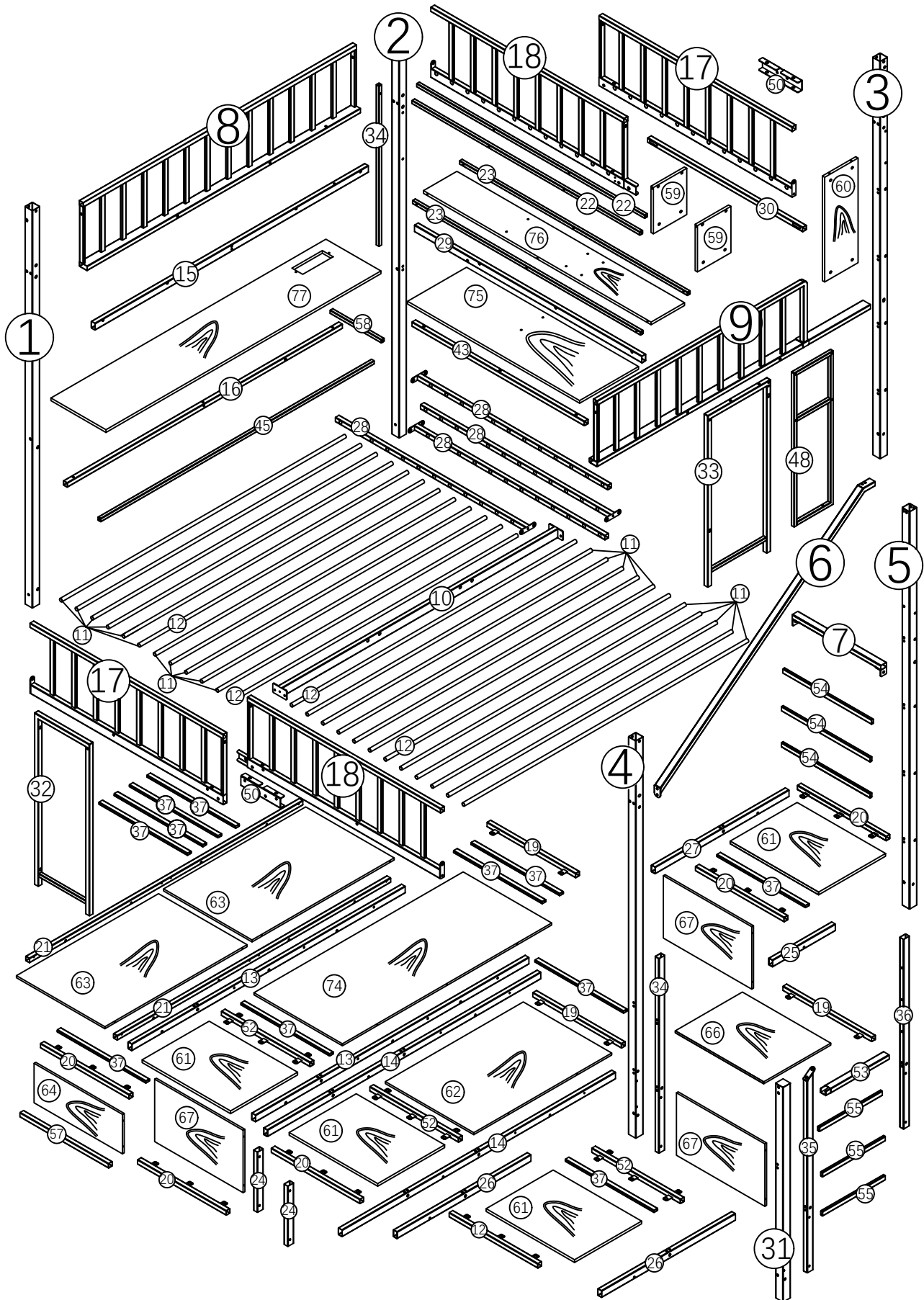

# MONTAGEANLEITUNG

SKU: N623P377895 / N623P377896 / N623P377897 / N623P377898

## DETAIL VIEW (DETAIL ANSICHT)

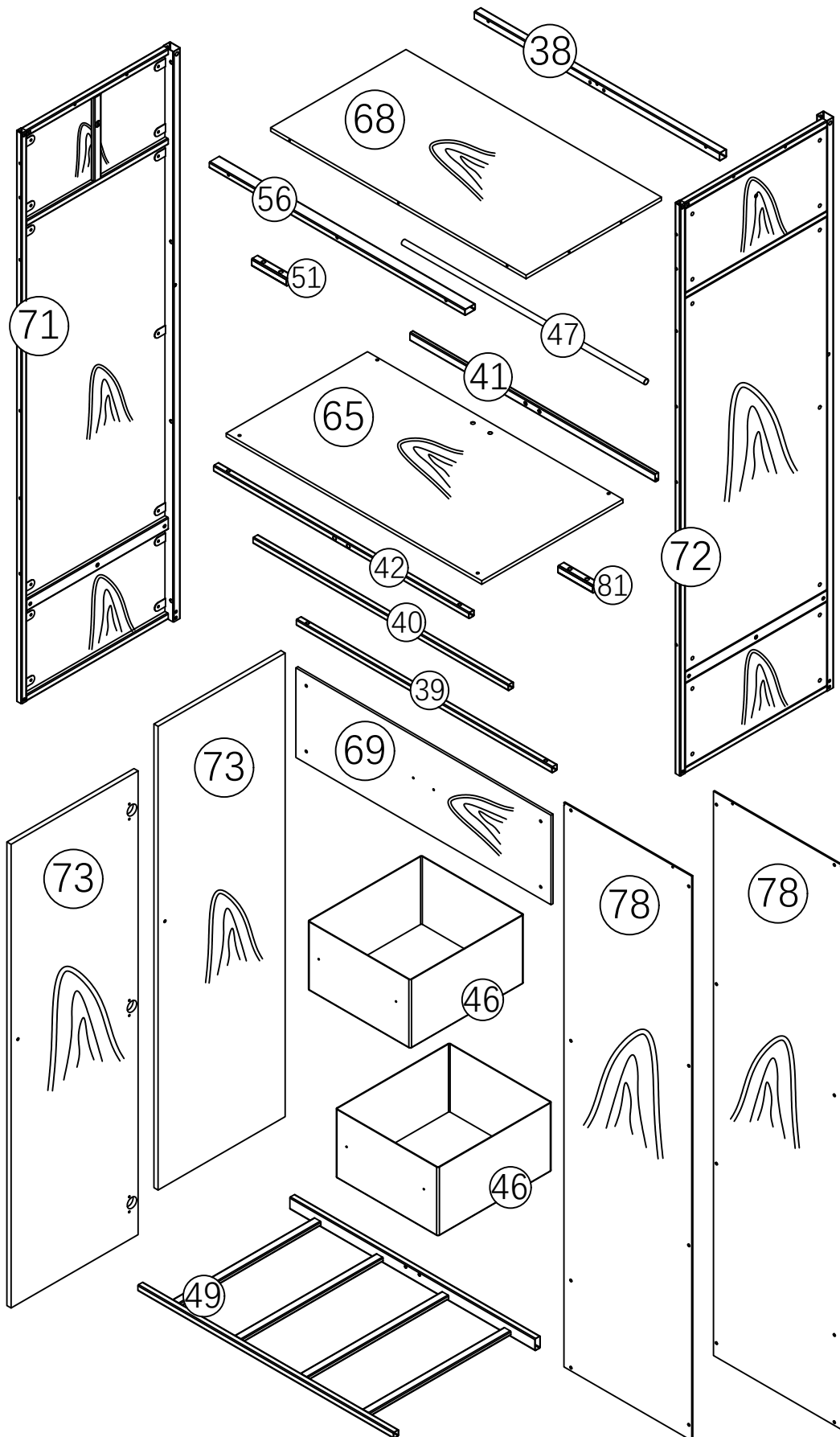



# MONTAGEANLEITUNG

SKU: N623P377895 / N623P377896 / N623P377897 / N623P377898

## PART LIST / STÜCKLISTE ( N623P377895 )



① 1 PCS

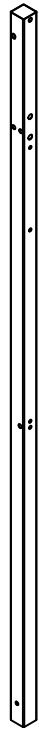

② 1 PCS



③ 1 PCS



④ 1 PCS



⑤ 1 PCS

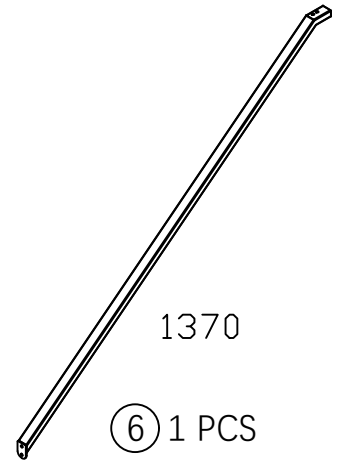

⑥ 1 PCS

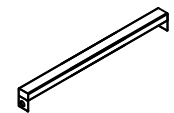

⑦ 1 PCS

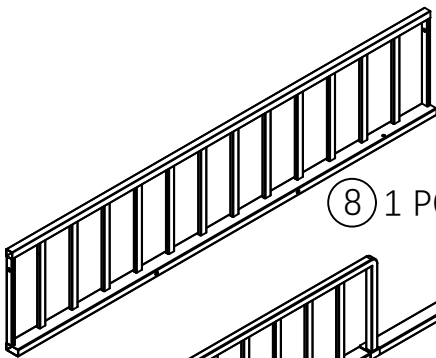

⑧ 1 PCS

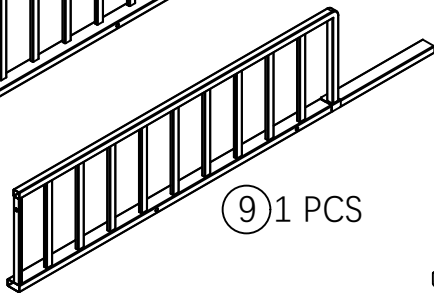

⑨ 1 PCS



Ø14  
758

⑩ 1 PCS

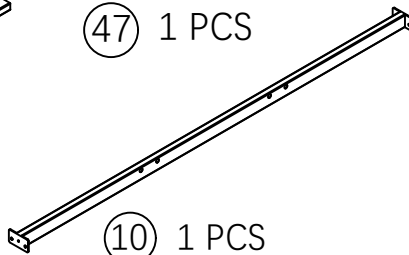

⑪ 1 PCS

⑫ 20 PCS

Ø14 1444

⑬ 4 PCS

Ø14 1444

Part 12 is threaded at both ends.

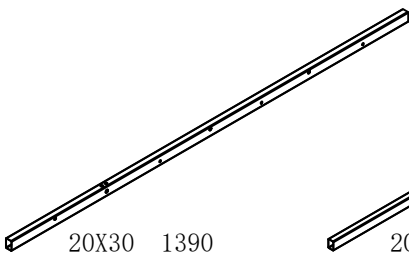

20X30 1390

⑬ 2 PCS

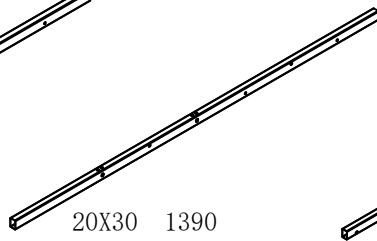

20X30 1390

⑭ 2 PCS

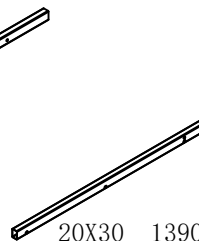

20X30 1390

⑮ 1 PCS

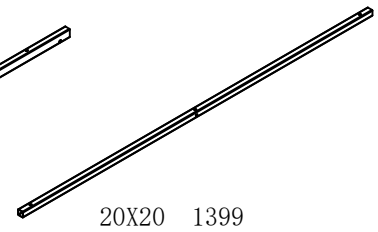

20X20 1399

⑯ 1 PCS

# MONTAGEANLEITUNG

SKU:N623P377895 / N623P377896 /N623P377897 /N623P377898

## PART LIST / STÜCKLISTE ( N623P377896 )

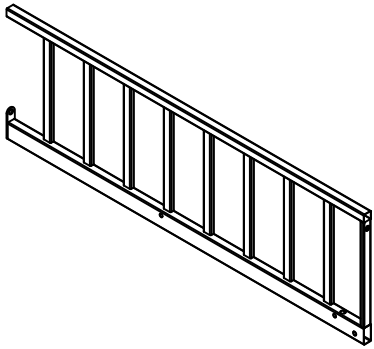

①⑦ 2 PCS

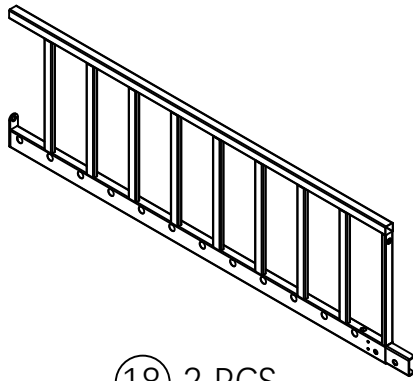

①⑧ 2 PCS

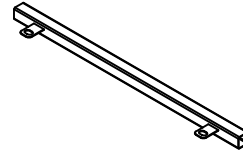

20X20 450

①⑨ 3 PCS

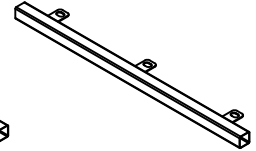

20X20 450

②⑩ 5 PCS

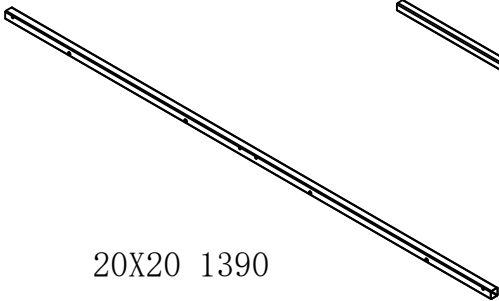

20X20 1390

②① 2 PCS

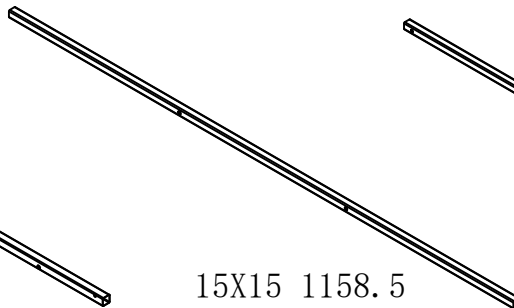

15X15 1158.5

②② 2 PCS

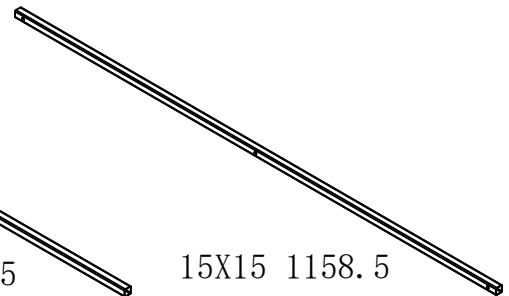

15X15 1158.5

②③ 2 PCS



20X30 265

②④ 3 PCS

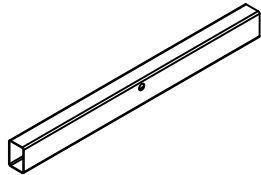

20X30 318.5

②⑤ 1 PCS

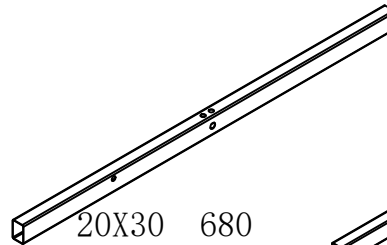

20X30 680

②⑥ 2 PCS

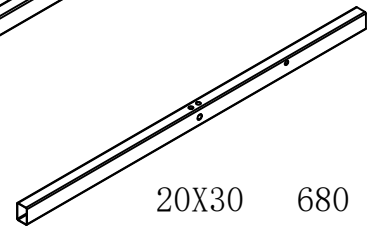

20X30 680

②⑦ 1 PCS

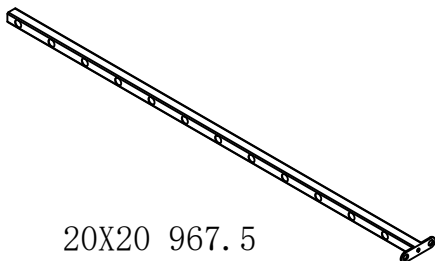

20X20 967.5

②⑧ 4 PCS

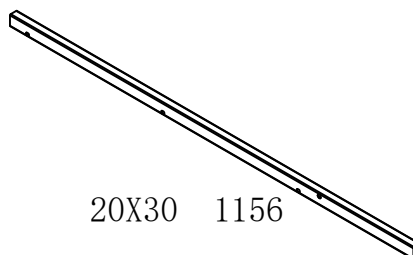

20X30 1156

②⑨ 1 PCS

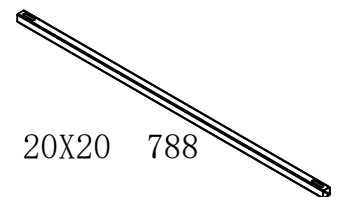

20X20 788

③⑩ 1 PCS

# MONTAGEANLEITUNG

SKU: N623P377895 / N623P377896 / N623P377897 / N623P377898

## PART LIST / STÜCKLISTE ( N623P377896 )



③① 1 PCS

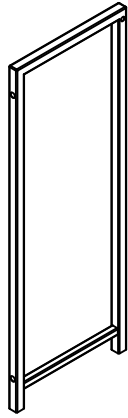

③② 1 PCS

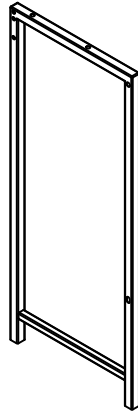

③③ 1 PCS



15X15 705

③④ 1 PCS



20X30 867

③⑤ 1 PCS



20X30 835

③⑥ 1 PCS

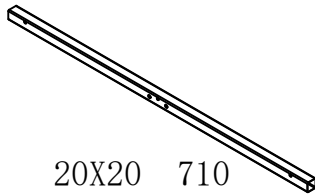

20X20 710

③⑧ 1 PCS

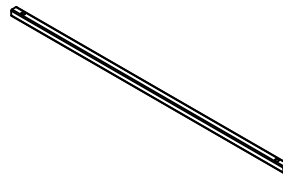

15X15 740

③⑨ 1 PCS

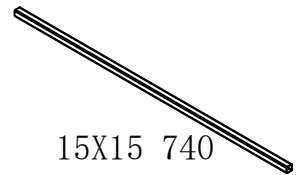

15X15 740

④① 1 PCS

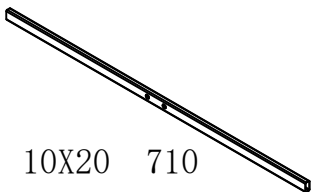

10X20 710

④① 1 PCS

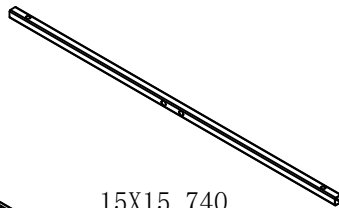

15X15 740

④② 1 PCS

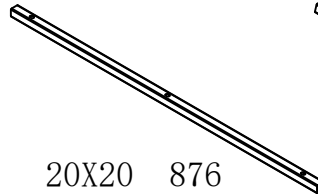

20X20 876

④③ 1 PCS

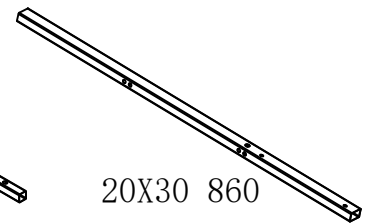

20X30 860

④④ 1 PCS

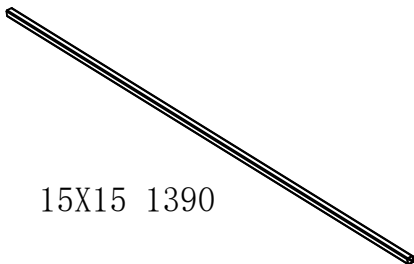

15X15 1390

④⑤ 1 PCS

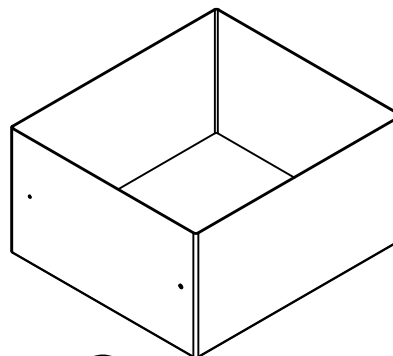

④⑥ 2 PCS

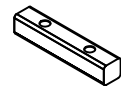

15X15 80

⑤① 1 PCS

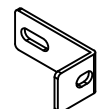

⑦⑨ \*2

# MONTAGEANLEITUNG

SKU: N623P377895 / N623P377896 / N623P377897 / N623P377898

## PART LIST / STÜCKLISTE ( N623P377897 )

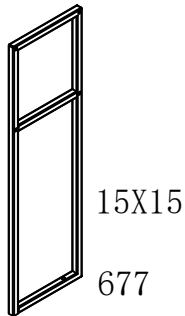

④⑧ 1 PCS

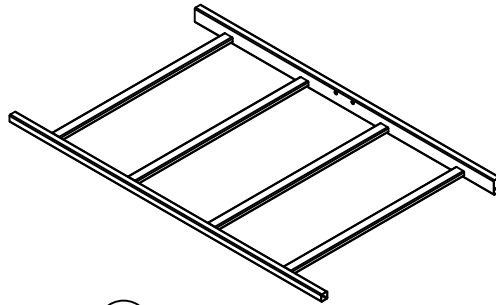

④⑨ 1 PCS

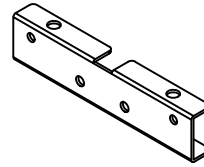

⑤⑩ 2 PCS

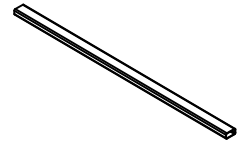

10X20 450  
③⑦ 11 PCS

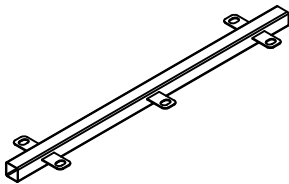

20X20 450  
⑤② 3 PCS

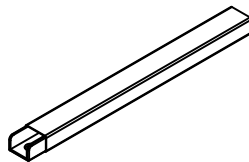

20X30 296.5  
⑤③ 1 PCS

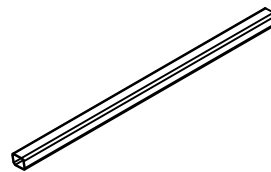

15X15 450  
⑤④ 3 PCS

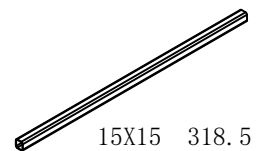

15X15 318.5  
⑤⑤ 3 PCS

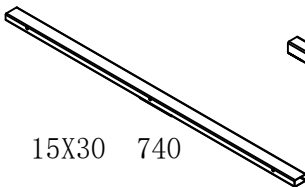

⑤⑥ 1 PCS

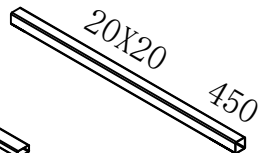

⑤⑦ 1 PCS

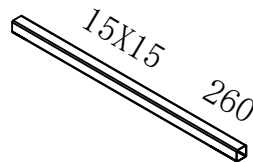

⑤⑧ 1 PCS



170 X 205 12mm  
⑤⑨ 2 PCS



170 X 461 12mm  
⑥⑩ 1 PCS

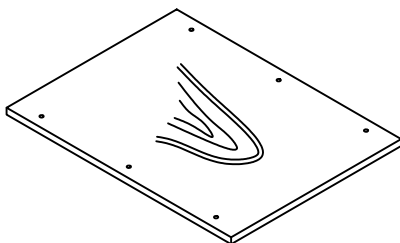

341 X 450 12mm  
⑥① 4 PCS

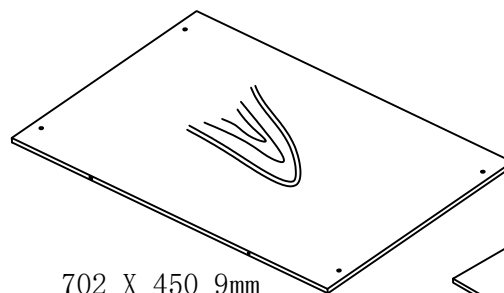

702 X 450 9mm  
⑥② 1 PCS

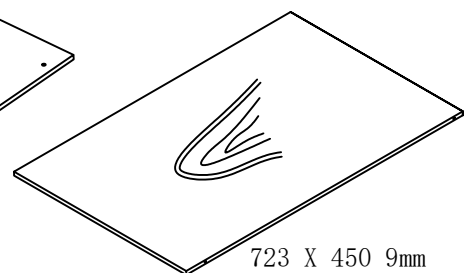

⑥③ 2 PCS

# MONTAGEANLEITUNG

SKU: N623P377895 / N623P377896 / N623P377897 / N623P377898

## PART LIST / STÜCKLISTE ( N623P377897 )

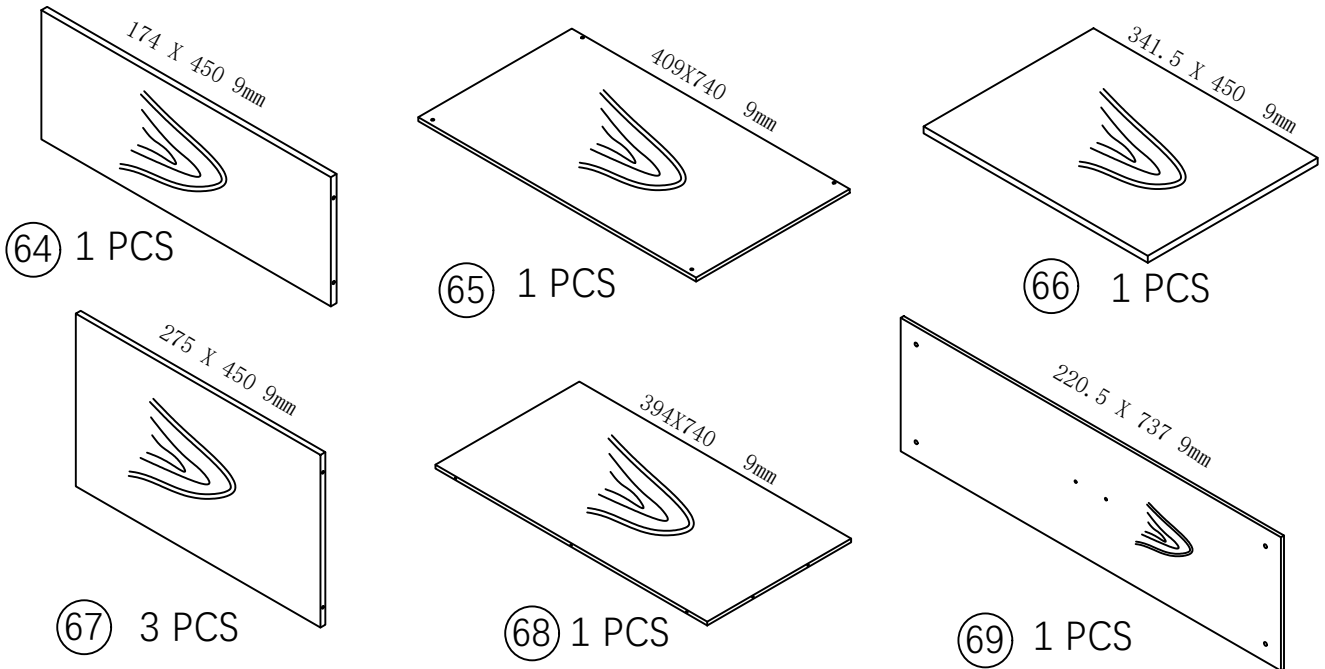

## HARDWARE LIST/HARDWARE-LISTE ( N623P377896 )

<b>(A) *1</b> 	<b>(B) *1</b> 	<b>(C)</b>  *1 *1 *2 *2	<b>(D) *28</b>  M6X10	<b>(E) *30</b>  M6X20	
<b>(F) *10</b>  M6X28	<b>(G) *56</b>  M6X35	<b>(H) *38</b>  M6X45	<b>(I) *51</b>  M6X55	<b>(J) *6</b>  M6X20	
<b>(K) *2</b>  M4X20	<b>(L) *7</b>  M8X16	<b>(M) *34</b>  M8X35	<b>(N) *5</b>  M8X45	<b>(O) *34</b>  M8X55	
<b>(P) *14</b>  M8X20	<b>(Q) *14</b>  M3.5X10	<b>(R) *26</b>  M5X45	<b>(S) *41</b>  M4X40	<b>(T) *7</b>  M4X50	
<b>(U) *26</b> 	<b>(V) *1 Knob</b>  M4X25	<b>(W) *1 Knob</b>  M4X20	<b>(X) *6</b>  M3.5X12 *36	<b>(Y) *2</b>  M6X50	<b>(Z) *4</b>  M6

# MONTAGEANLEITUNG

SKU: N623P377895 / N623P377896 / N623P377897 / N623P377898

## PART LIST / STÜCKLISTE ( N623P377898 )



1400mm

70 1 PCS

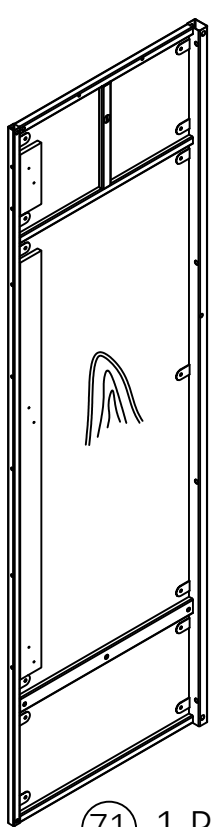

71 1 PCS

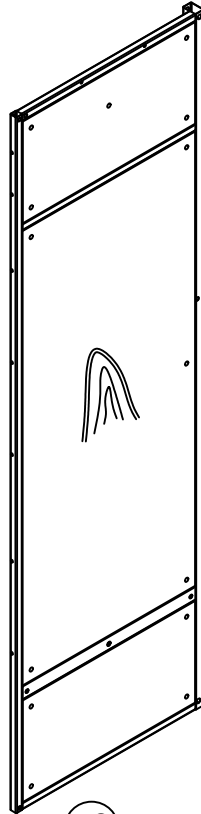

72 1 PCS

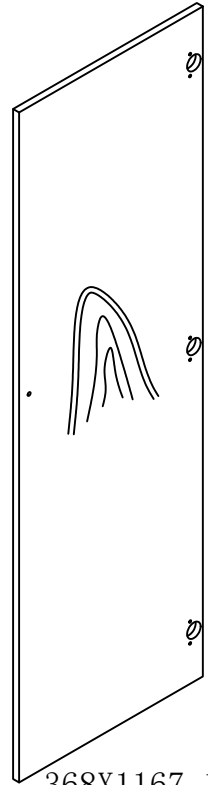

368X1167 12mm

73 2 PCS

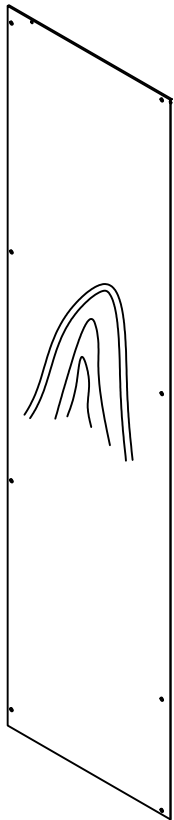

368X1405 3mm

78 2 PCS

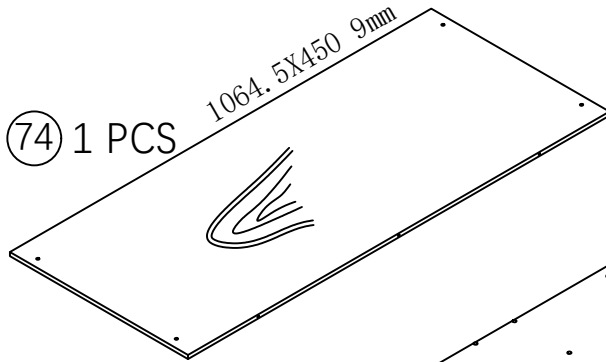

74 1 PCS

1064,5X450 9mm

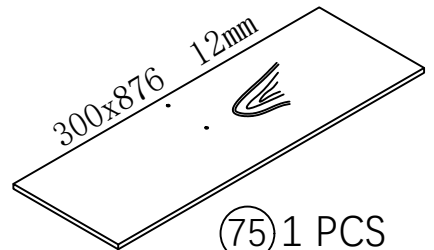

75 1 PCS

300x876 12mm

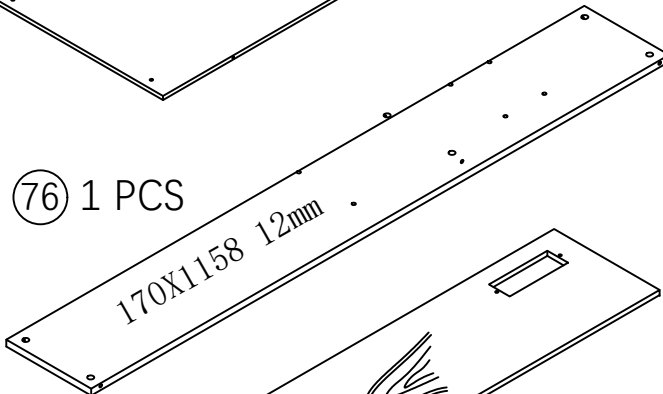

76 1 PCS

170X1158 12mm

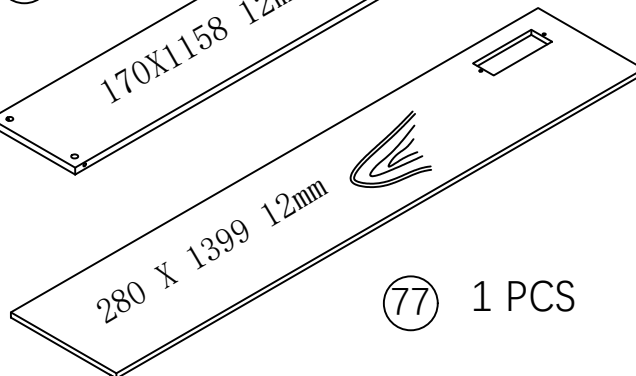

77 1 PCS

280 X 1399 12mm

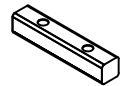

80 15X15 70

The packaging for this part contains screws.

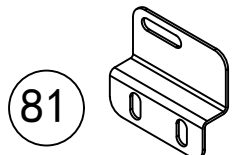

81

ⓐ M6\*35 8PCS

Ⓢ M4\*40 8PCS

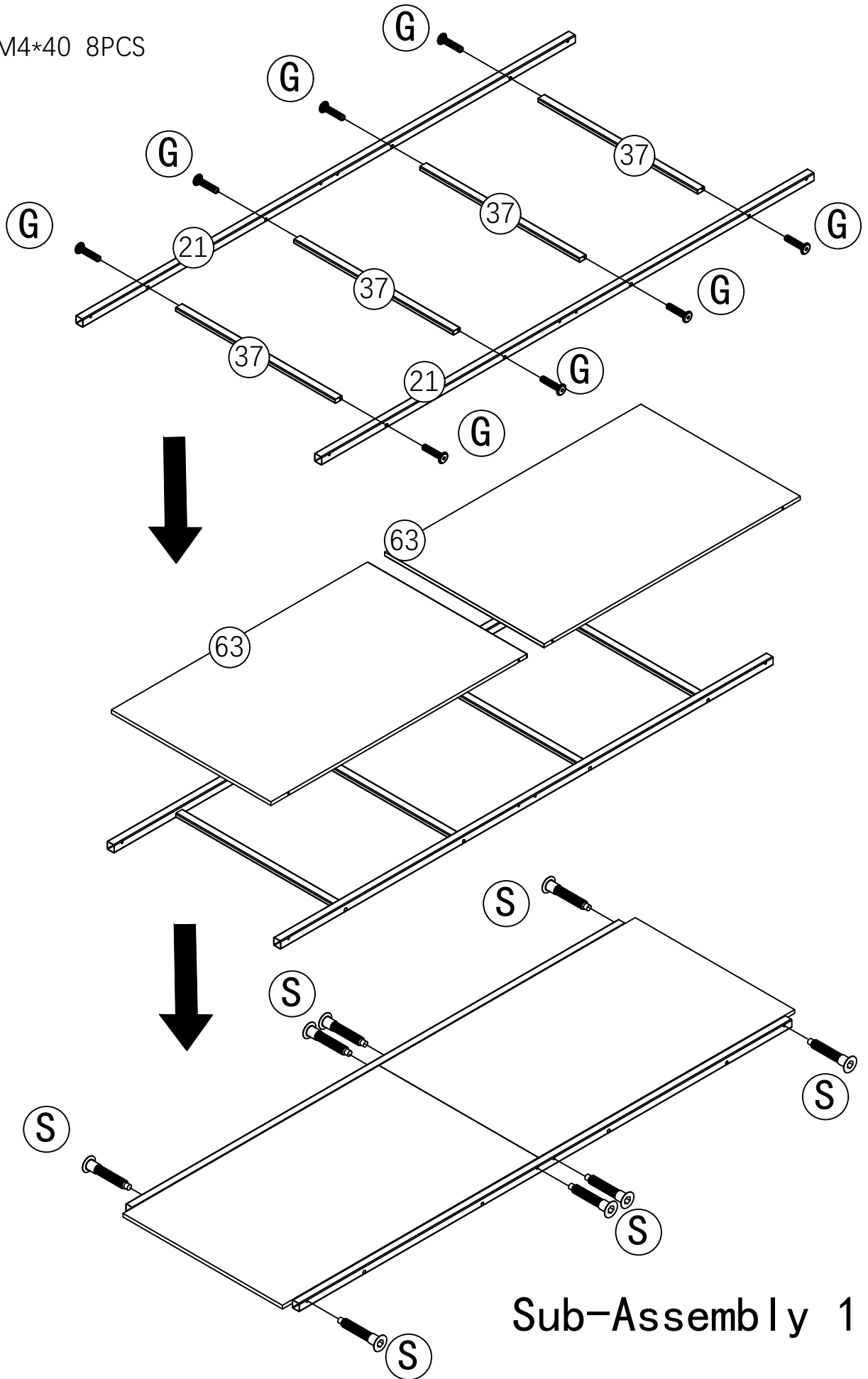

Sub-Assembly 1

- ⓓ M6\*10 6PCS
- ⓖ M6\*35 6PCS
- Ⓜ M8\*35 2PCS
- Ⓚ M3.5\*10 4PCS
- Ⓢ M4\*40 6PCS

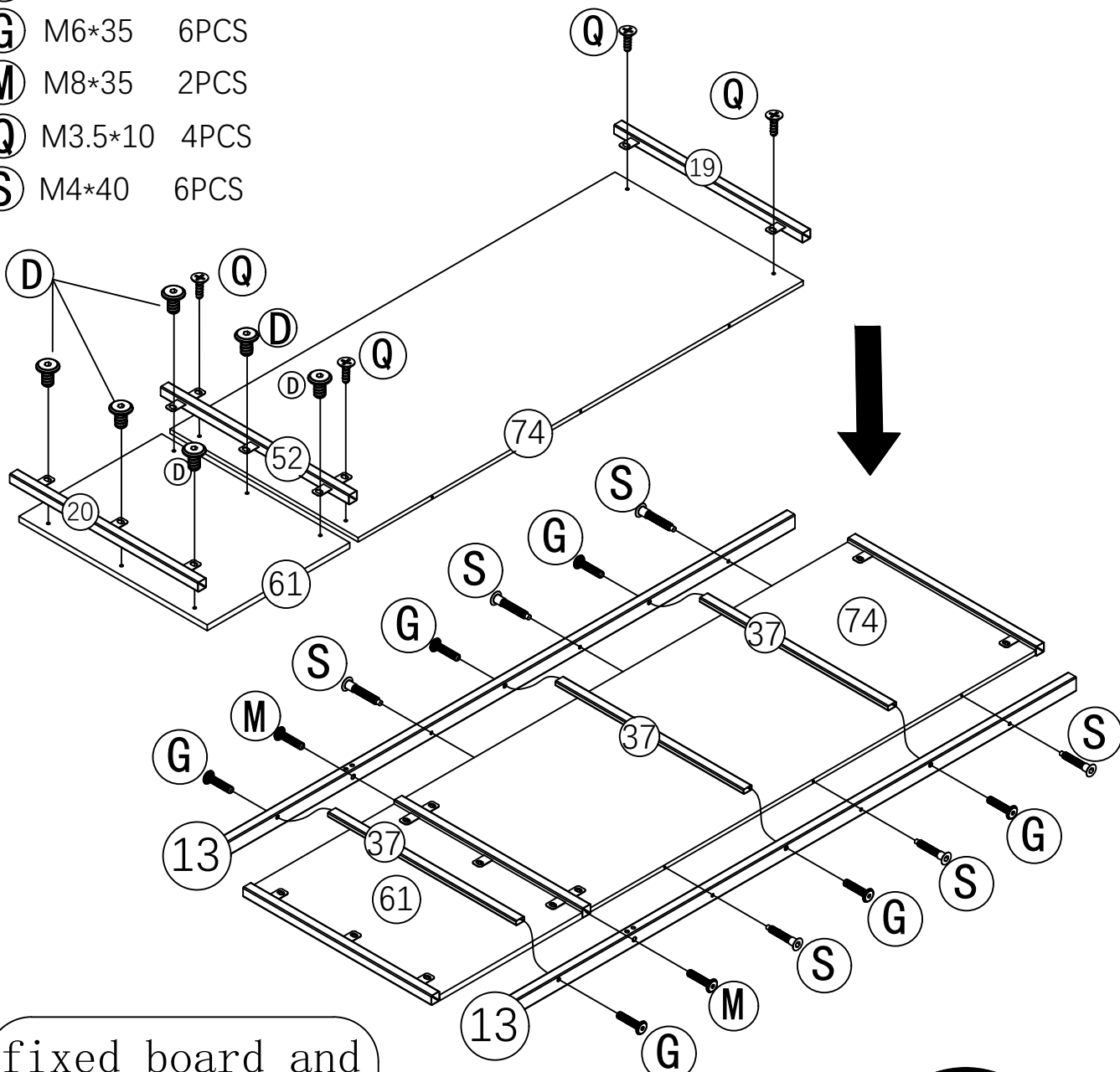

fixed board and then turn over

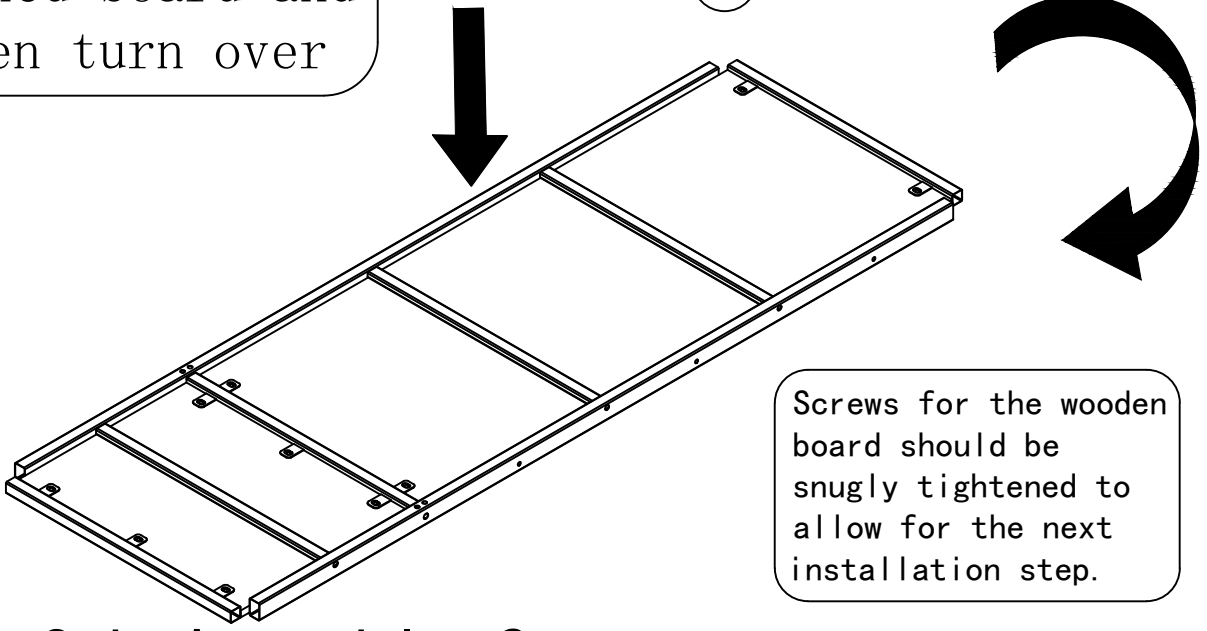

Screws for the wooden board should be snugly tightened to allow for the next installation step.

## Sub-Assembly 2



- Ⓓ M6\*10 6PCS
- Ⓖ M6\*35 4PCS
- Ⓜ M8\*35 4PCS
- Ⓚ M3.5\*10 4PCS
- Ⓢ M4\*40 4PCS

fixed board and then turn over

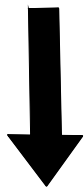
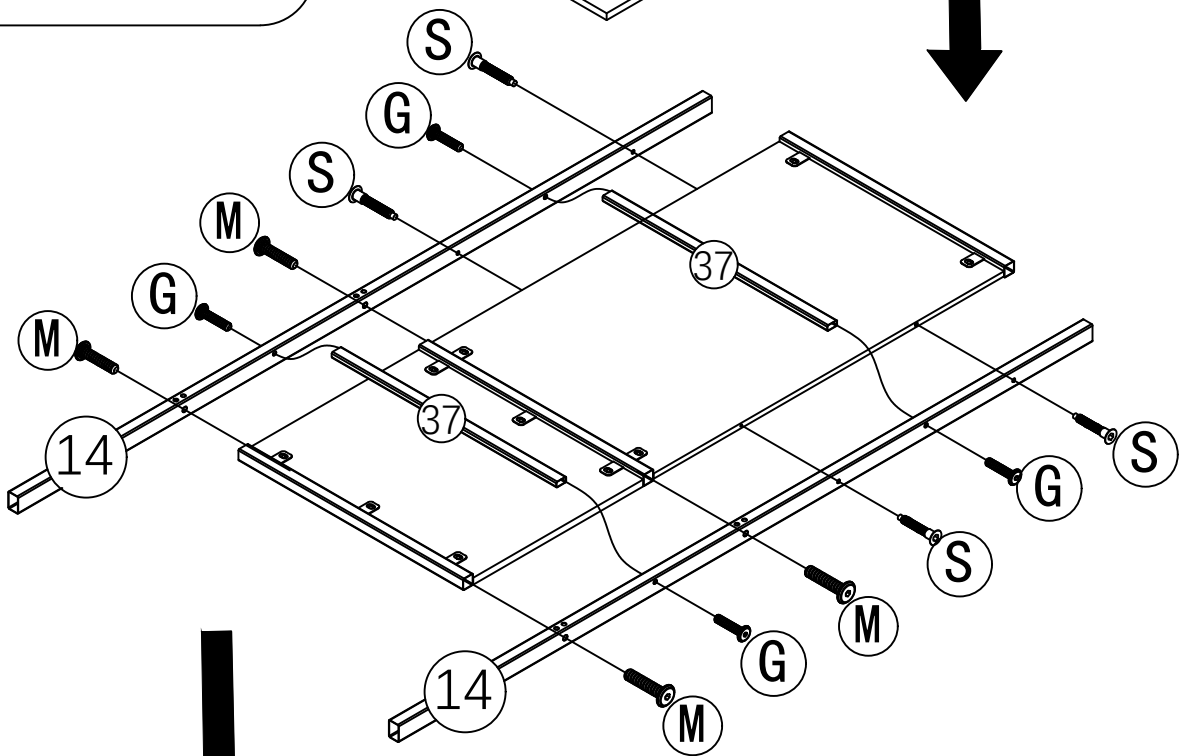
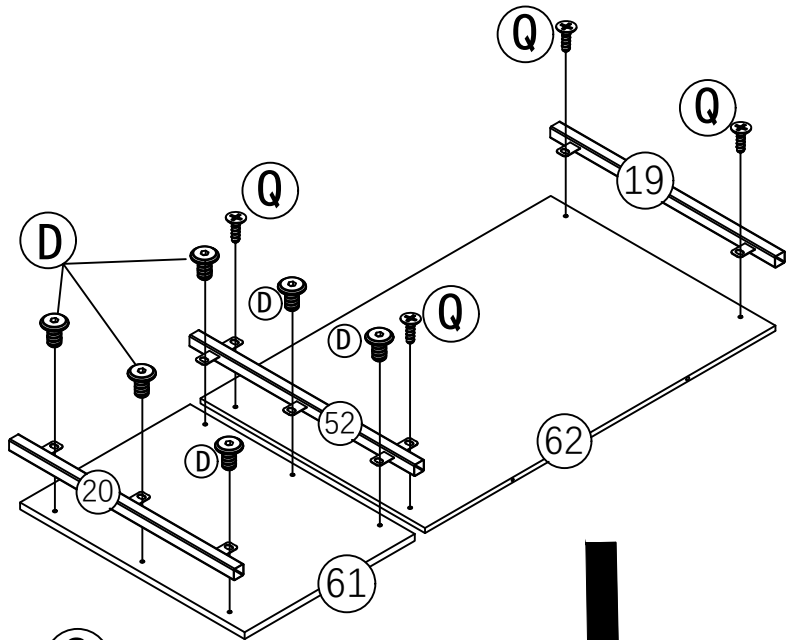

Screws for the wooden board should be snugly tightened to allow for the next installation step.

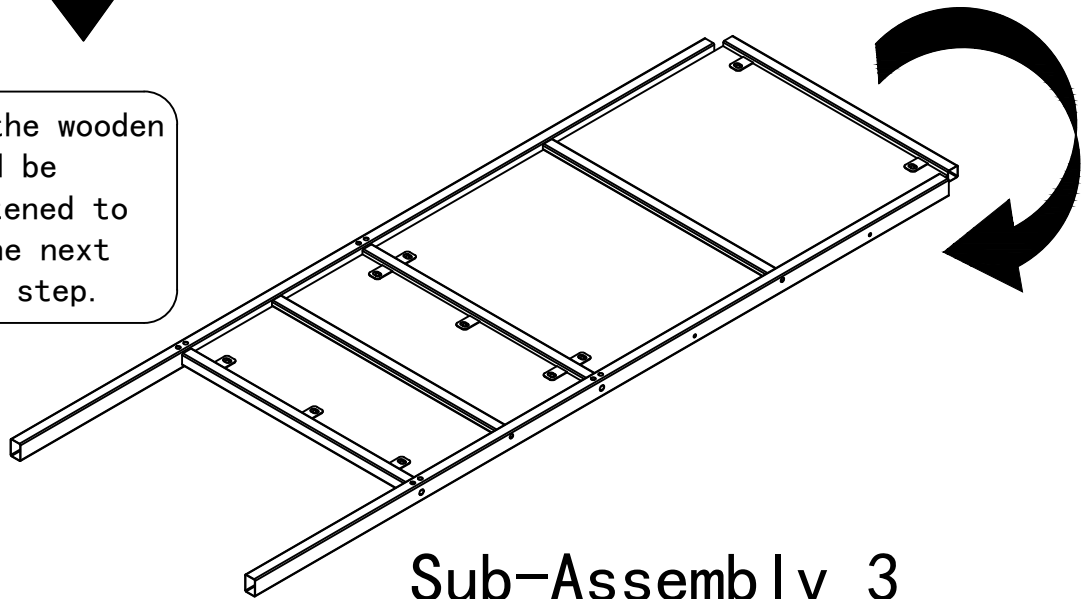

### Sub-Assembly 3

- ⓓ M6\*10 12PCS      Ⓚ M3.5\*10 4PCS
- ⓖ M6\*35 4PCS
- Ⓜ M8\*35 3PCS

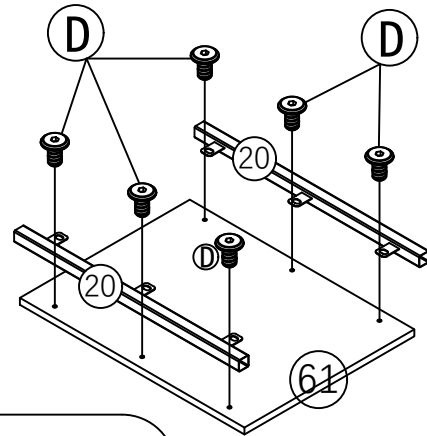
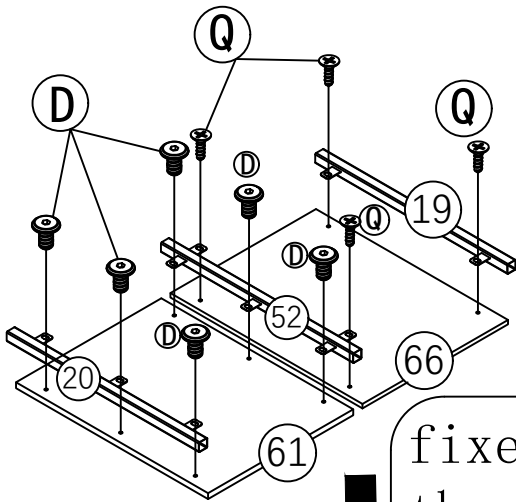

fixed board and  
then turn over

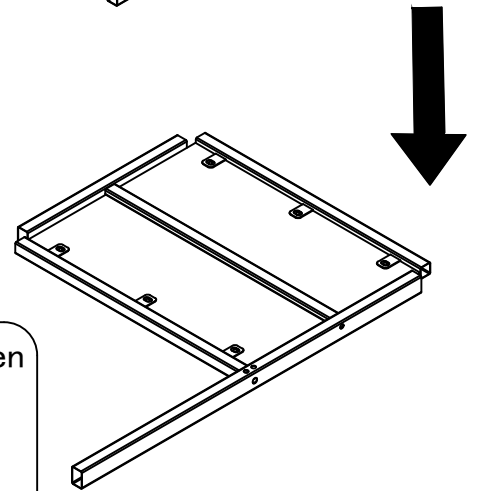
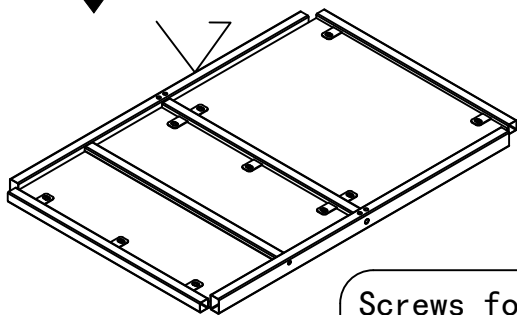
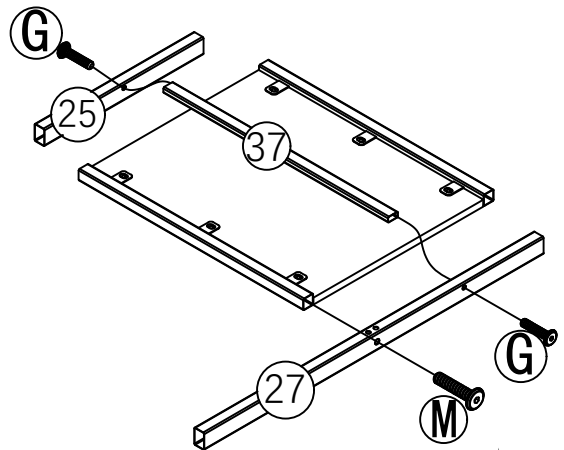
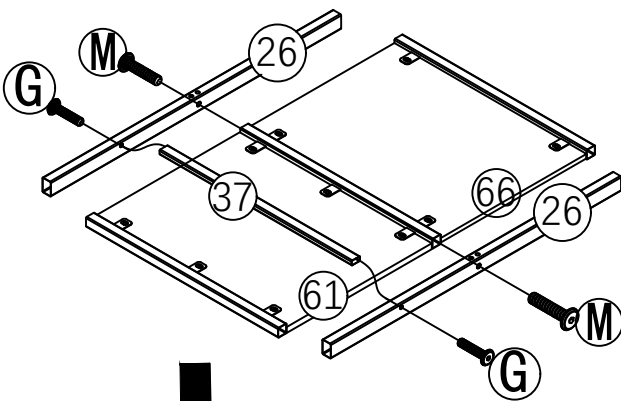

Screws for the wooden  
board should be  
snugly tightened to  
allow for the next  
installation step.

Sub-Assembly 4

Sub-Assembly 5

- ⓐ M6\*20 1PCS
- ⓑ M6\*35 3PCS
- ⓒ M6\*55 12PCS
- ⓓ M8\*55 4PCS

All bolts shown in the picture just need turn to the position of 80% for next steps

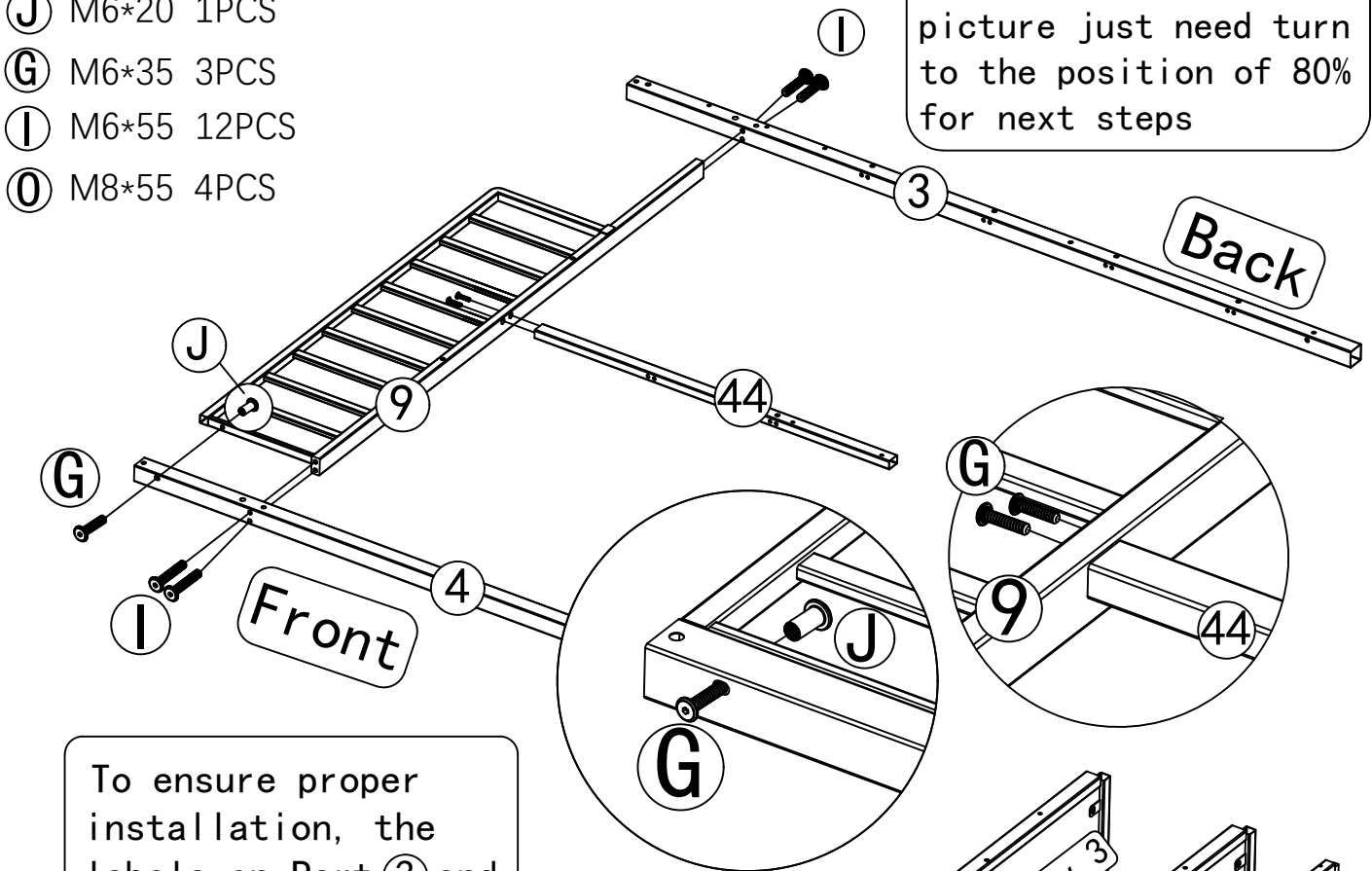

To ensure proper installation, the labels on Part ③ and Part ④ must be oriented towards the front.

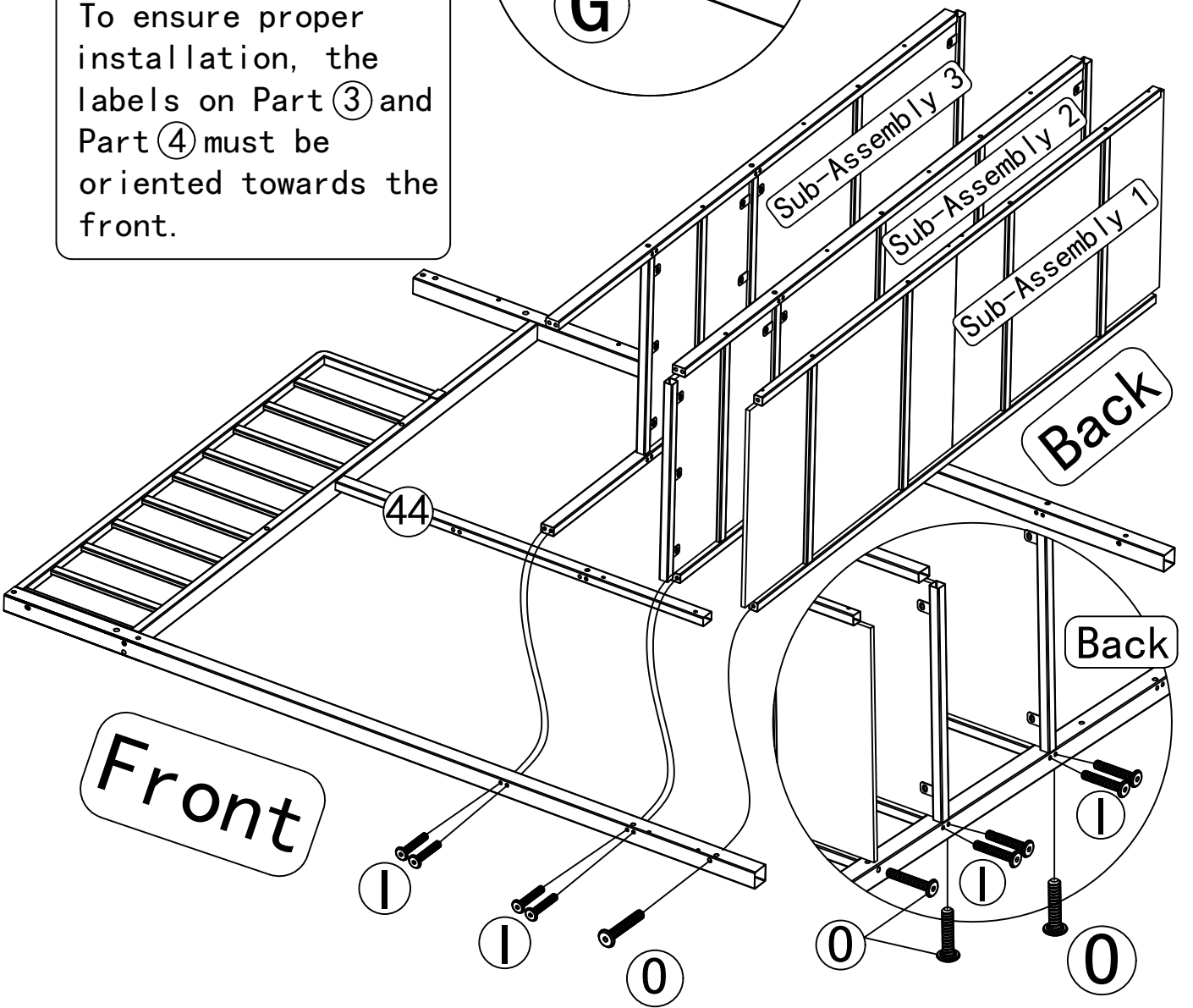

Front

H M6\*45 2PCS

I M6\*55 14PCS

O M8\*55 7PCS

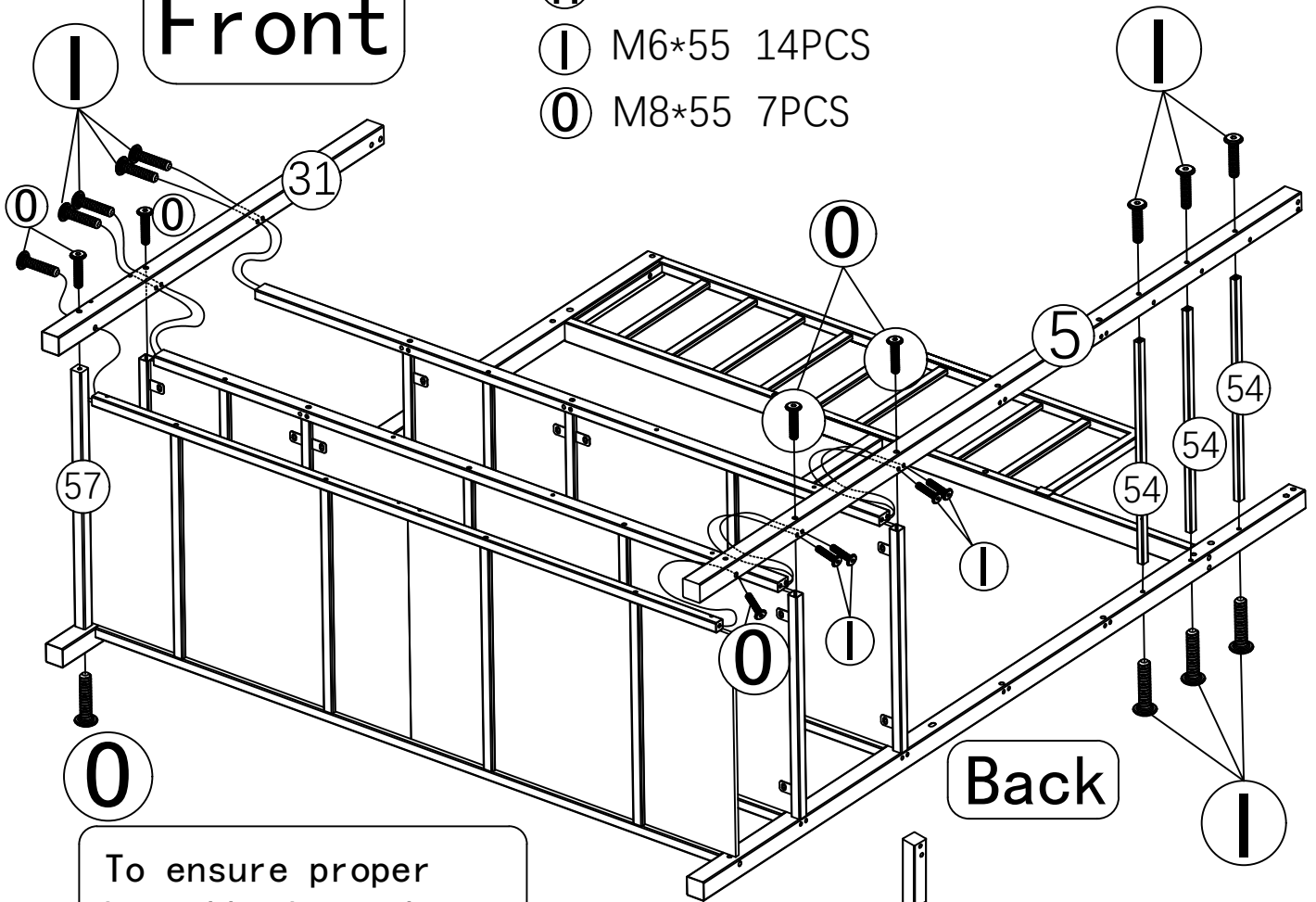

Back

Back

To ensure proper installation, the labels on Part 5 and Part 31 must be oriented towards the front.

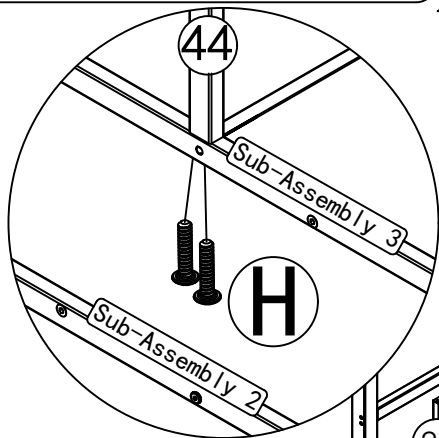

Front

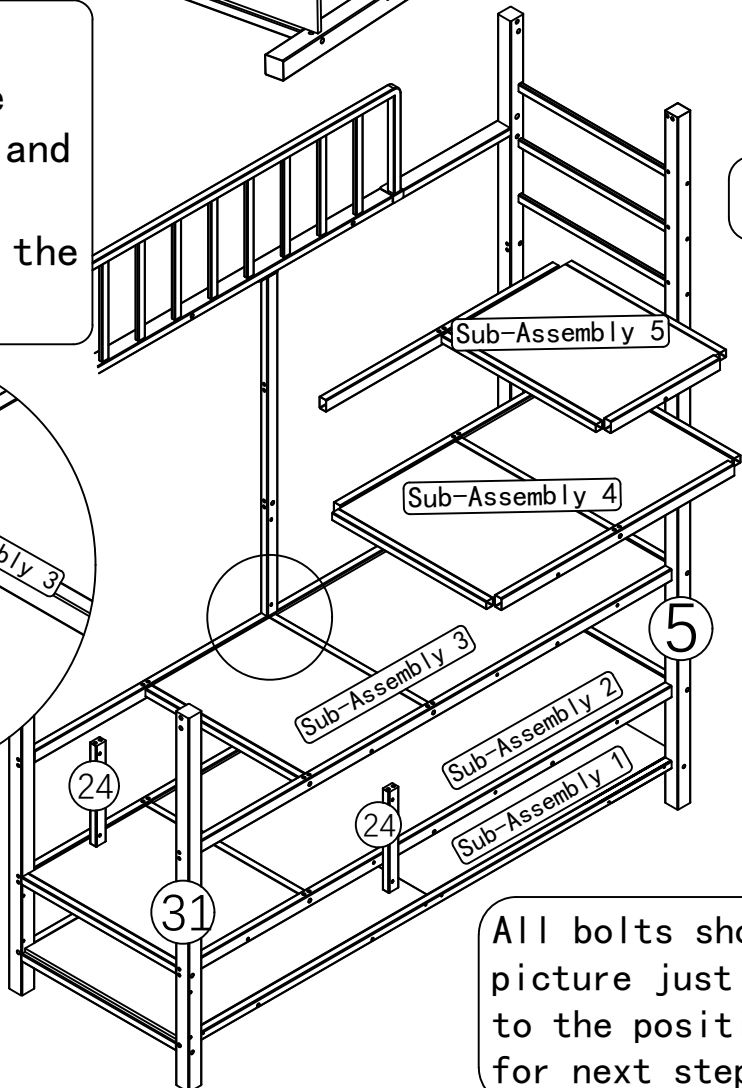

All bolts shown in the picture just need turn to the position of 80% for next steps

(H) M6\*45 25PCS

(I) M6\*55 11PCS

(M) M8\*35 3PCS

(O) M8\*55 4PCS

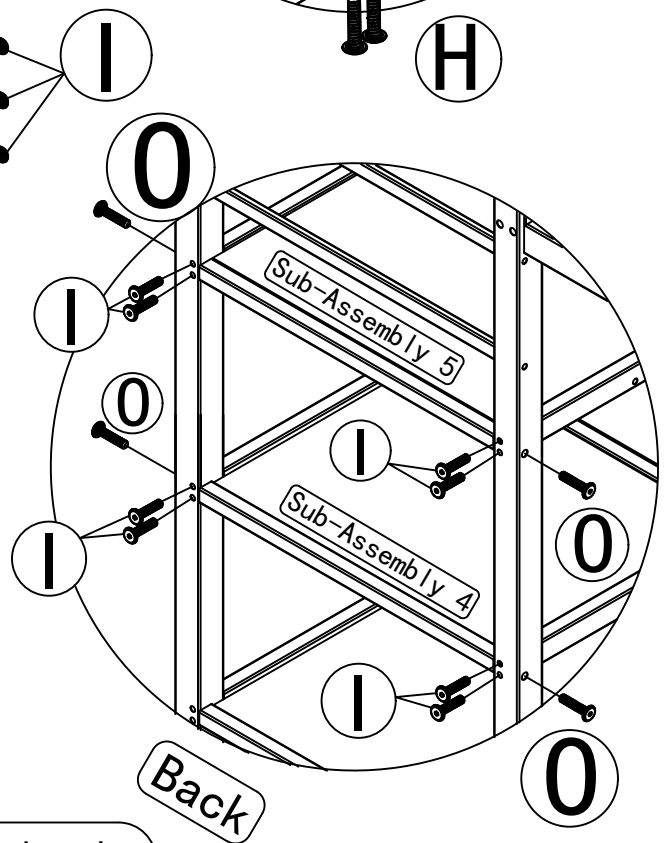
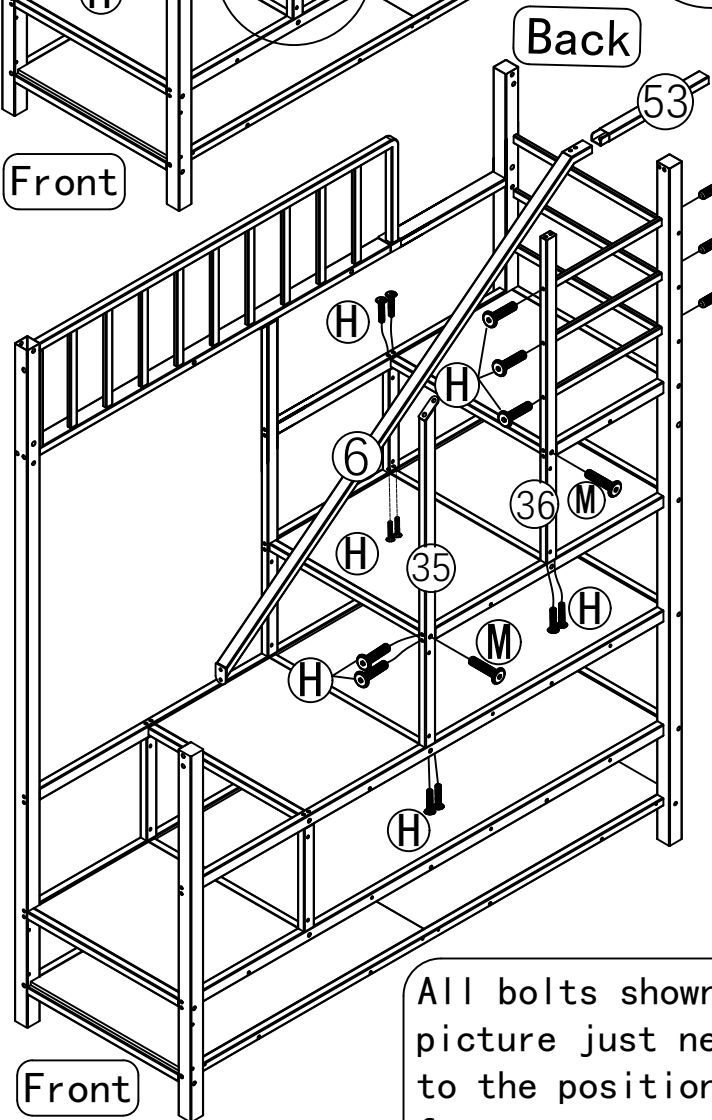
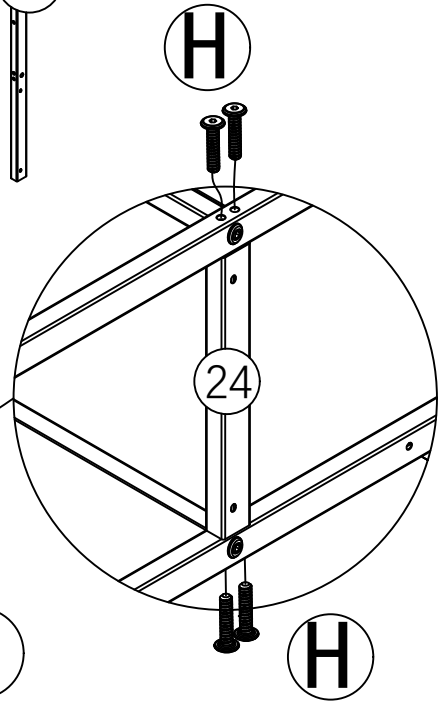
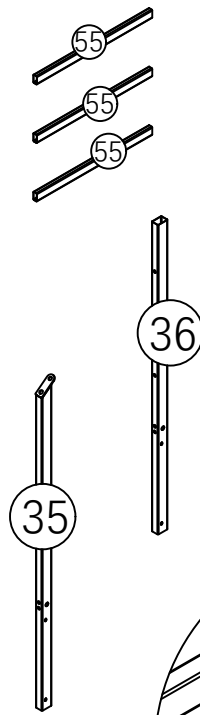
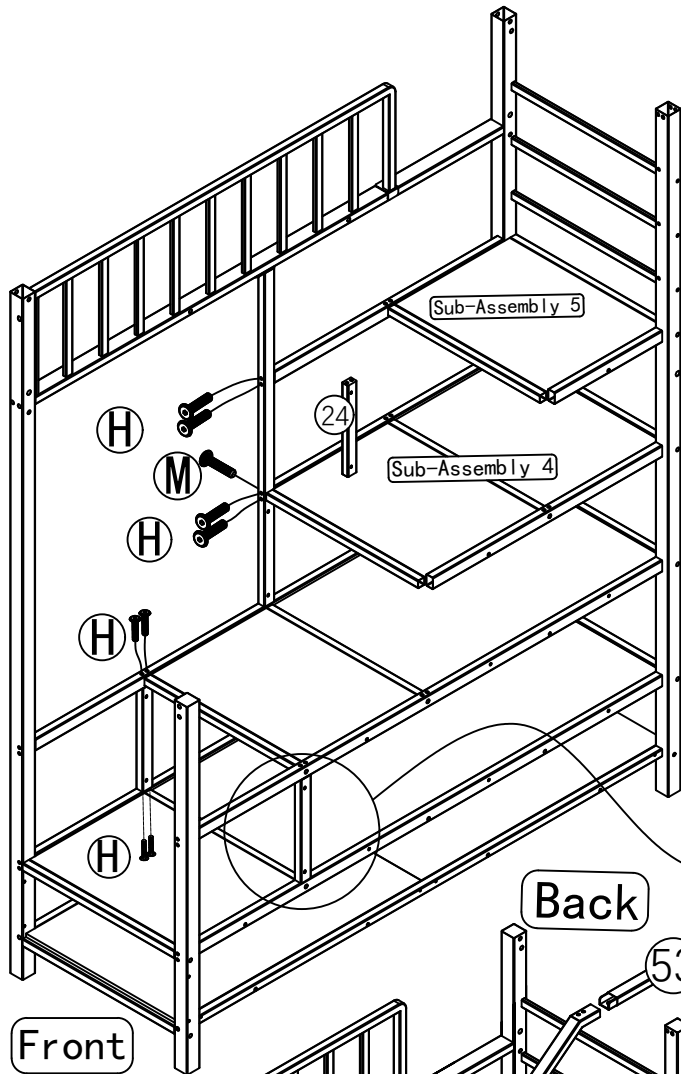

All bolts shown in the picture just need turn to the position of 80% for next steps

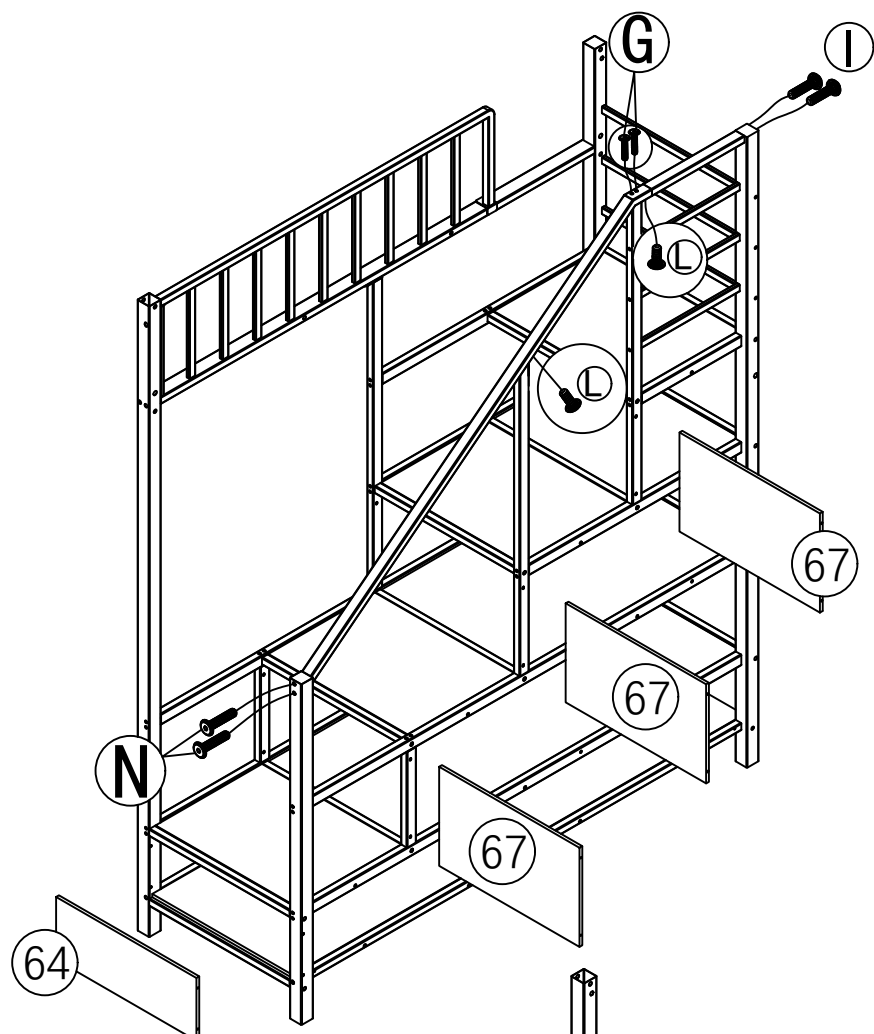

- Ⓒ M6\*35 2PCS
- Ⓘ M6\*55 2PCS
- Ⓛ M8\*16 2PCS
- Ⓝ M8\*45 2PCS
- Ⓢ M4\*40 12PCS
- Ⓣ M4\*50 4PCS

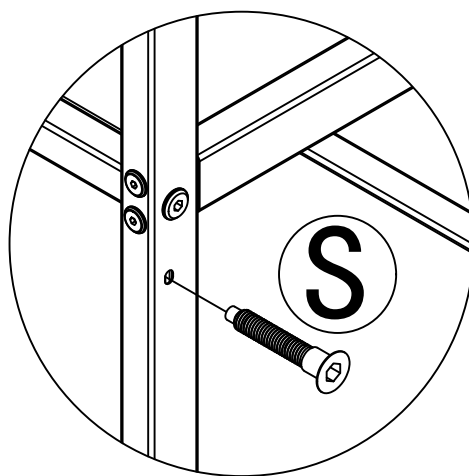
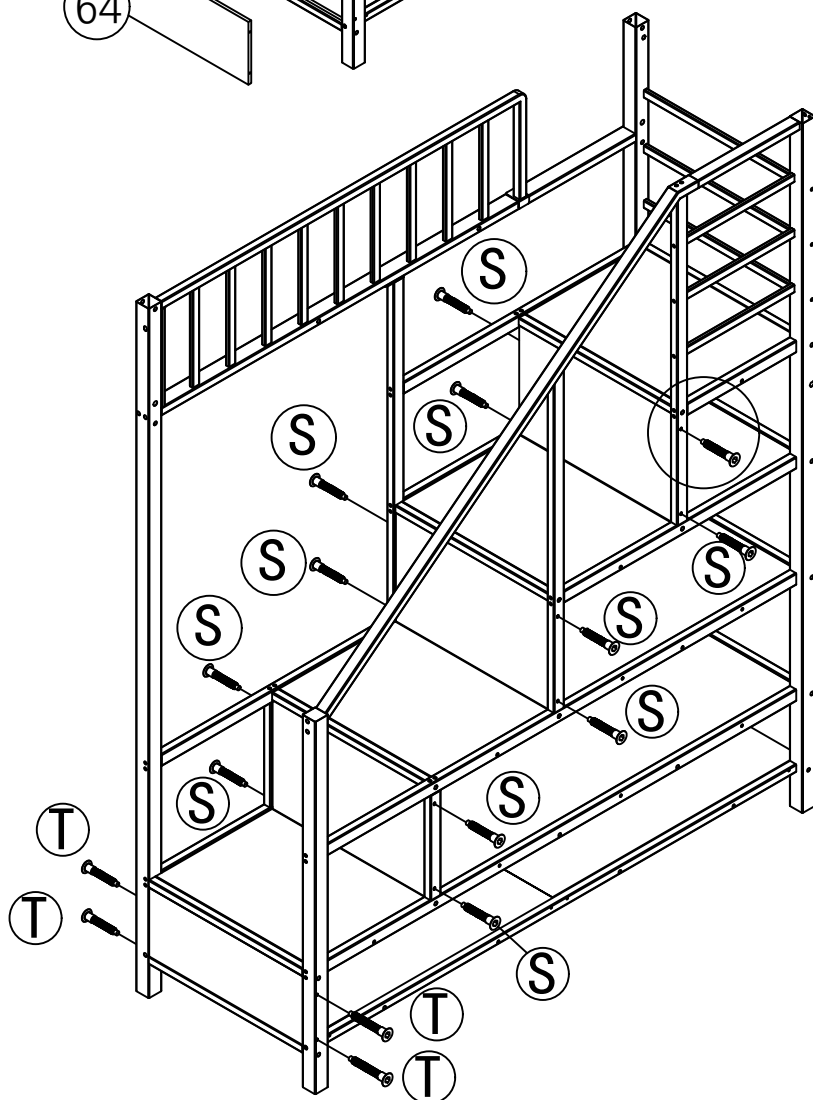

All bolts shown in the picture just need turn to the position of 80% for next steps

Ⓒ M6\*35 2PCS

Ⓘ M6\*55 6PCS

Ⓙ M6\*20 2PCS

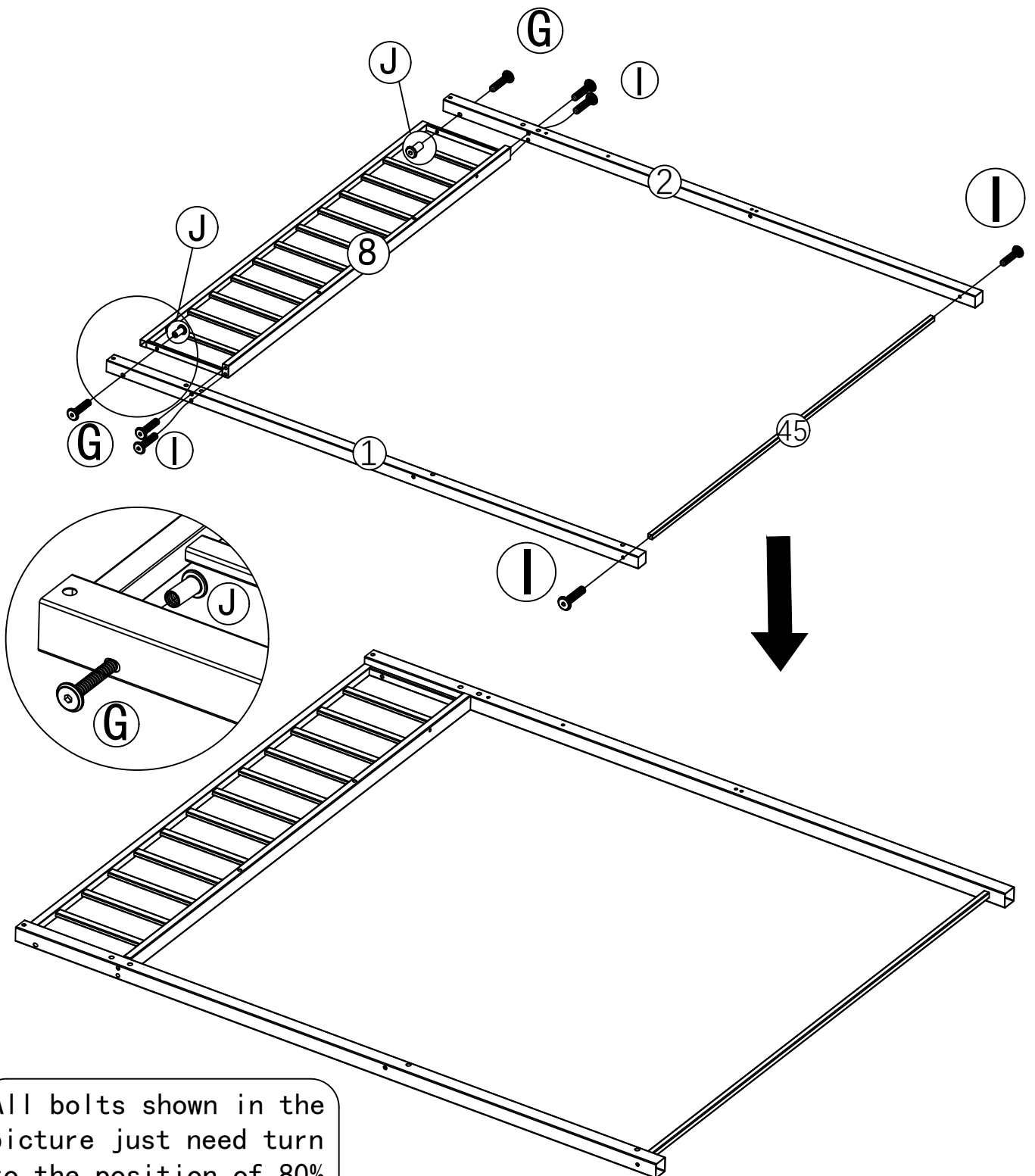

All bolts shown in the picture just need turn to the position of 80% for next steps

## Sub-Assembly 6

- ⓓ M6\*10 2PCS      Ⓜ M8\*35 4PCS
- ⓐ M6\*20 2PCS      Ⓟ M8\*20 4PCS

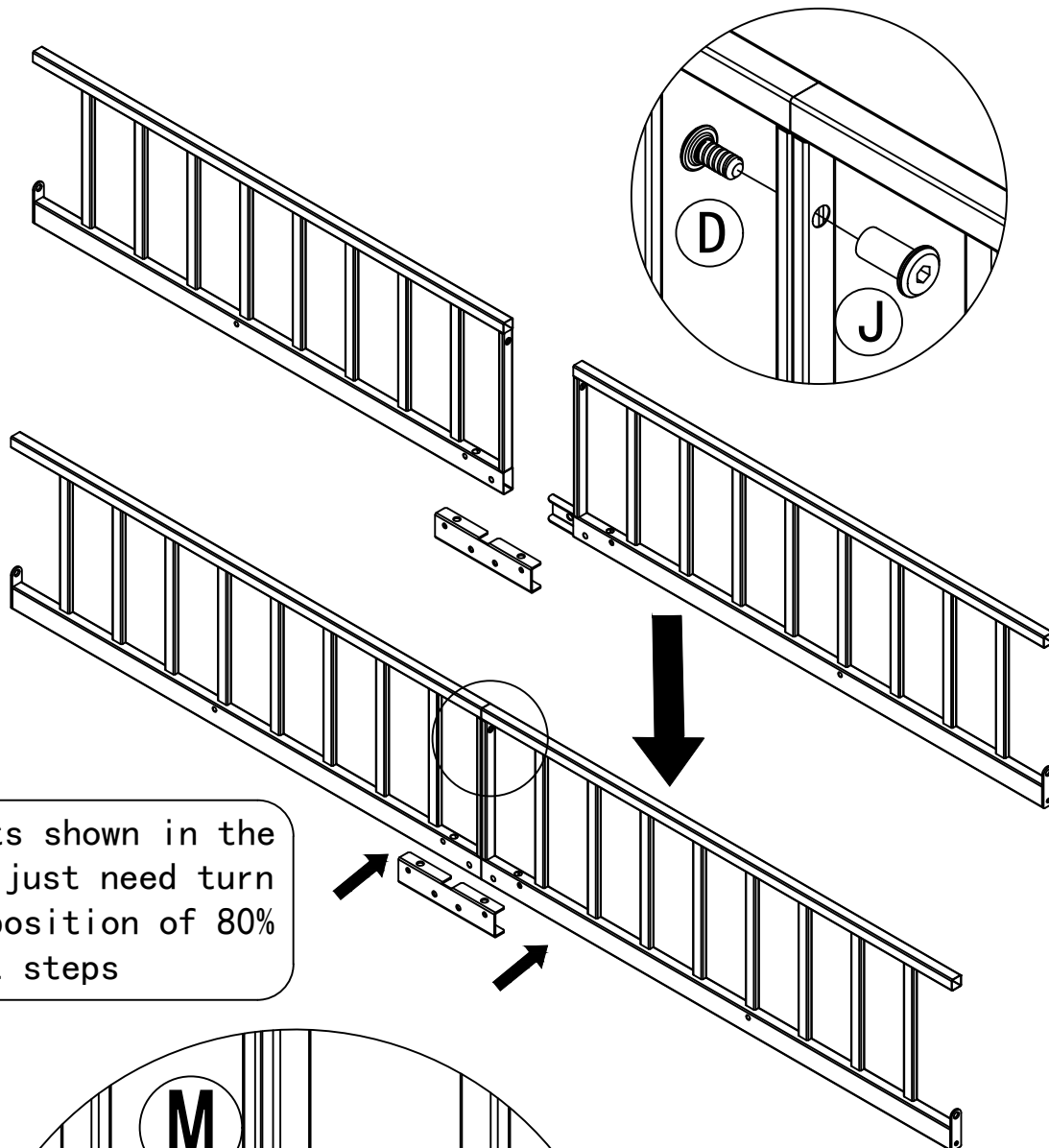

All bolts shown in the picture just need turn to the position of 80% for next steps

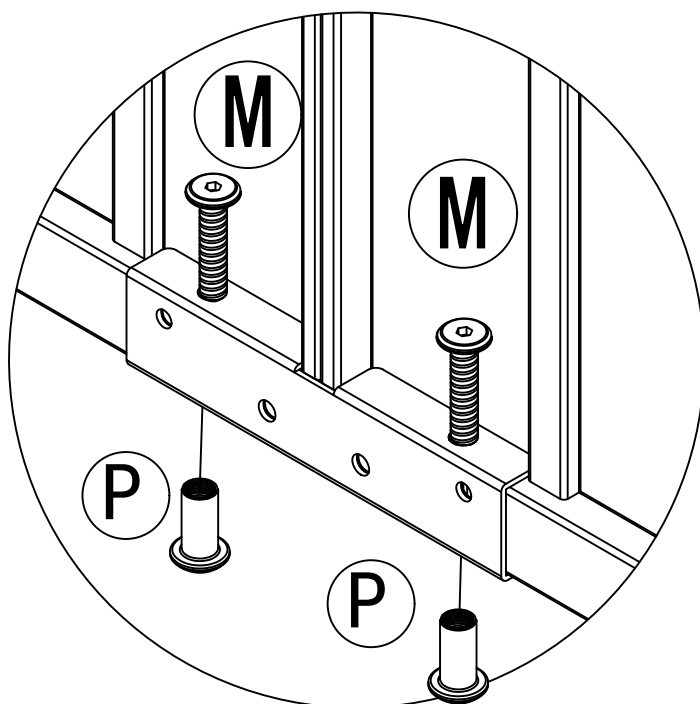

Installation  
Procedure X2

Sub-Assembly 7



- ⓕ M6\*28 3PCS    Ⓡ M5\*45 5PCS
- ⓖ M6\*35 2PCS    Ⓢ ⌀9\*10 5PCS
- Ⓜ M8\*35 2PCS
- ⓐ M8\*55 4PCS
- Ⓟ M8\*20 2PCS

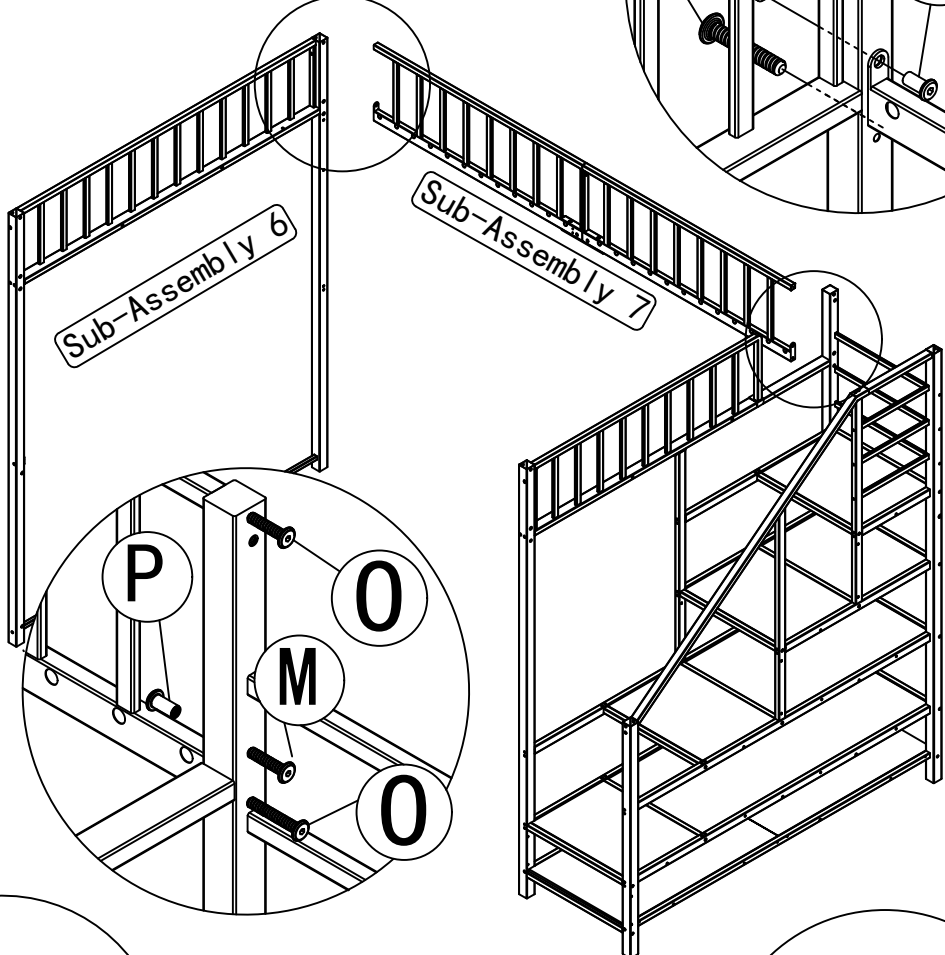
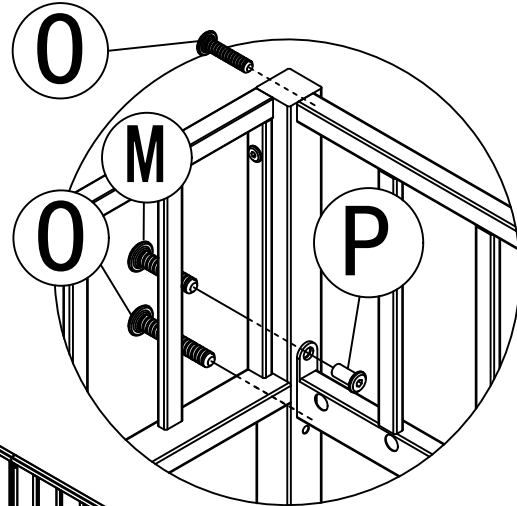

All bolts shown in the picture just need turn to the position of 80% for next steps

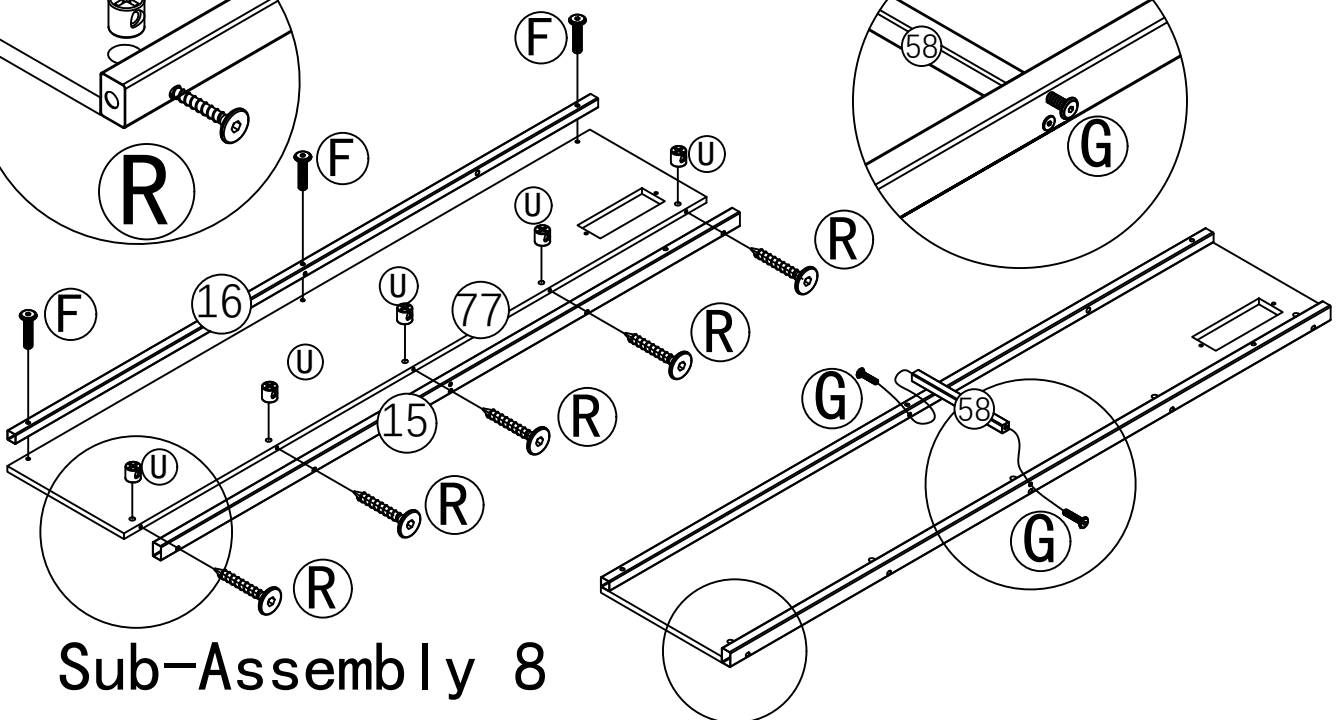
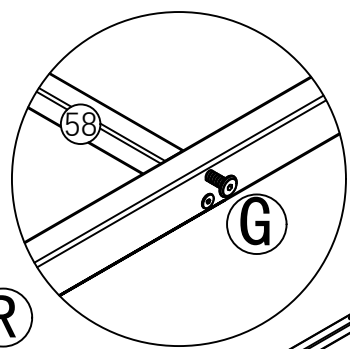
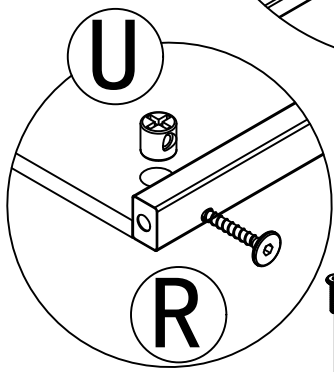
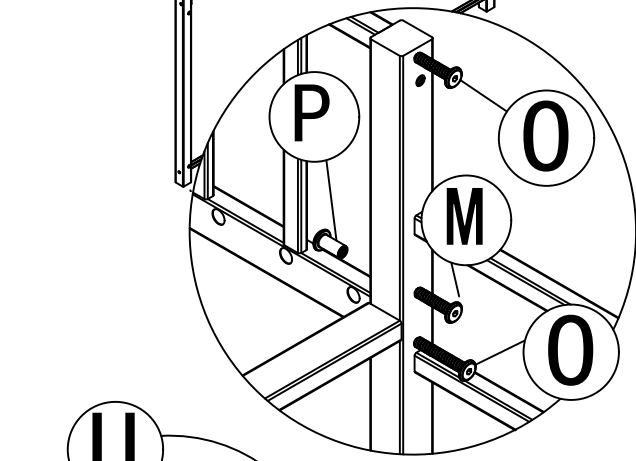

Sub-Assembly 8

- ⓕ M6\*28 3PCS
- Ⓡ M5\*45 9PCS
- Ⓢ ∅9\*10 9PCS

All bolts shown in the picture just need turn to the position of 80% for next steps

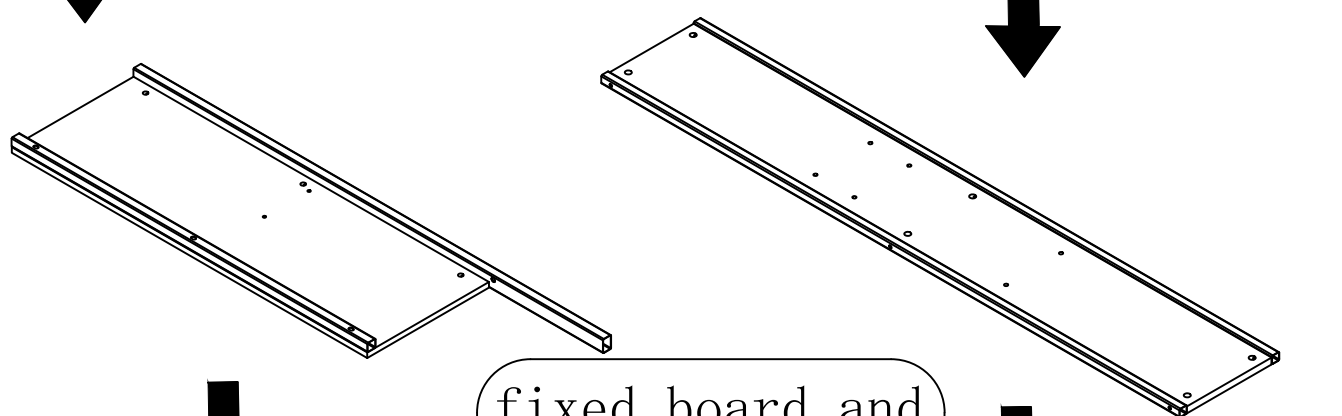
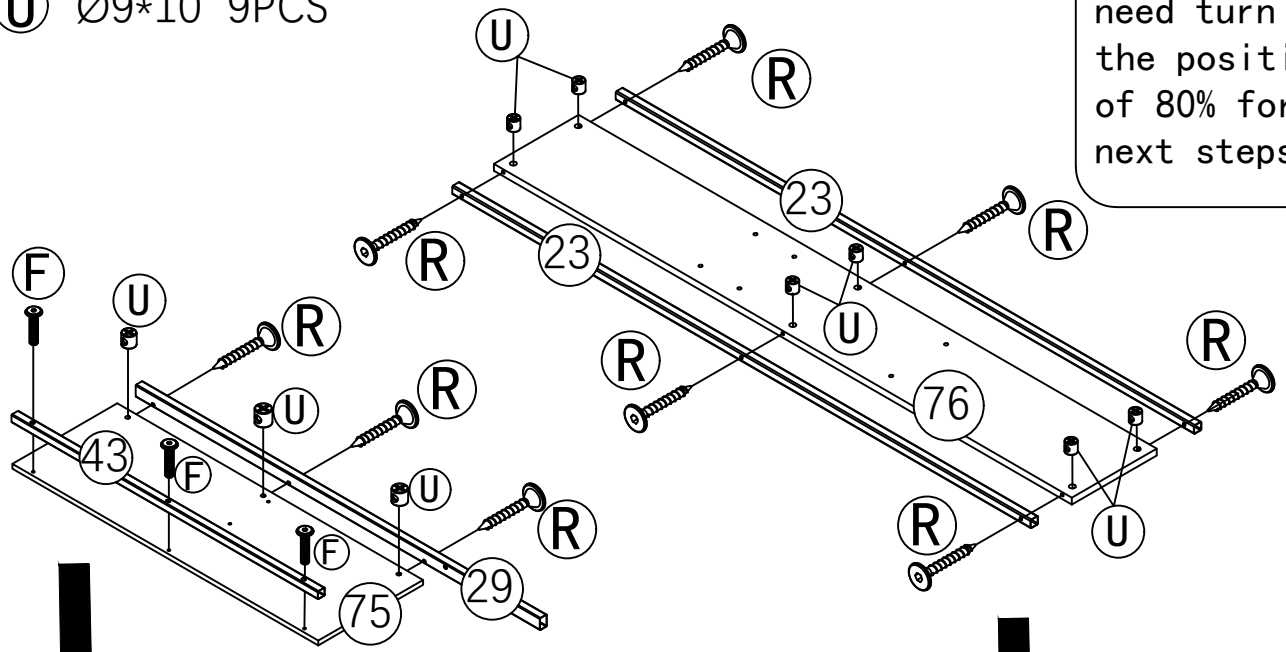

fixed board and then turn over

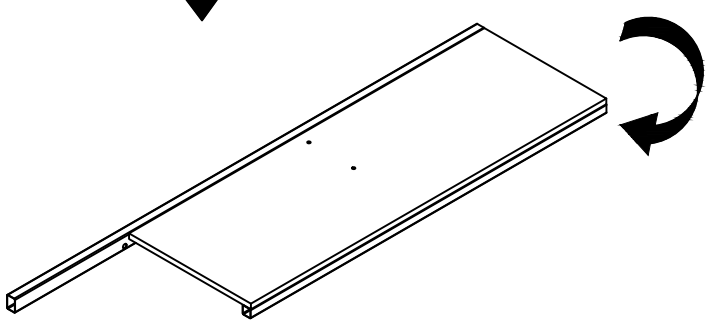

**Sub-Assembly 9**

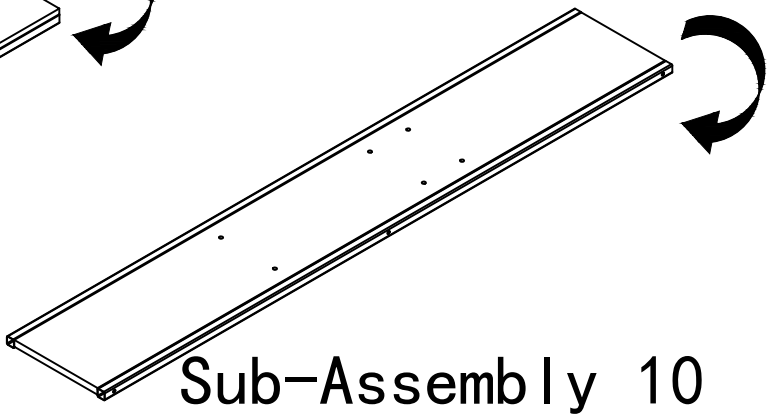

**Sub-Assembly 10**

All bolts shown in the picture just need turn to the position of 80% for next steps

- G** M6\*35 2PCS      **M** M8\*35 4PCS
- I** M6\*55 2PCS      **P** M8\*20 2PCS
- N** M8\*45 2PCS      **O** M8\*55 2PCS

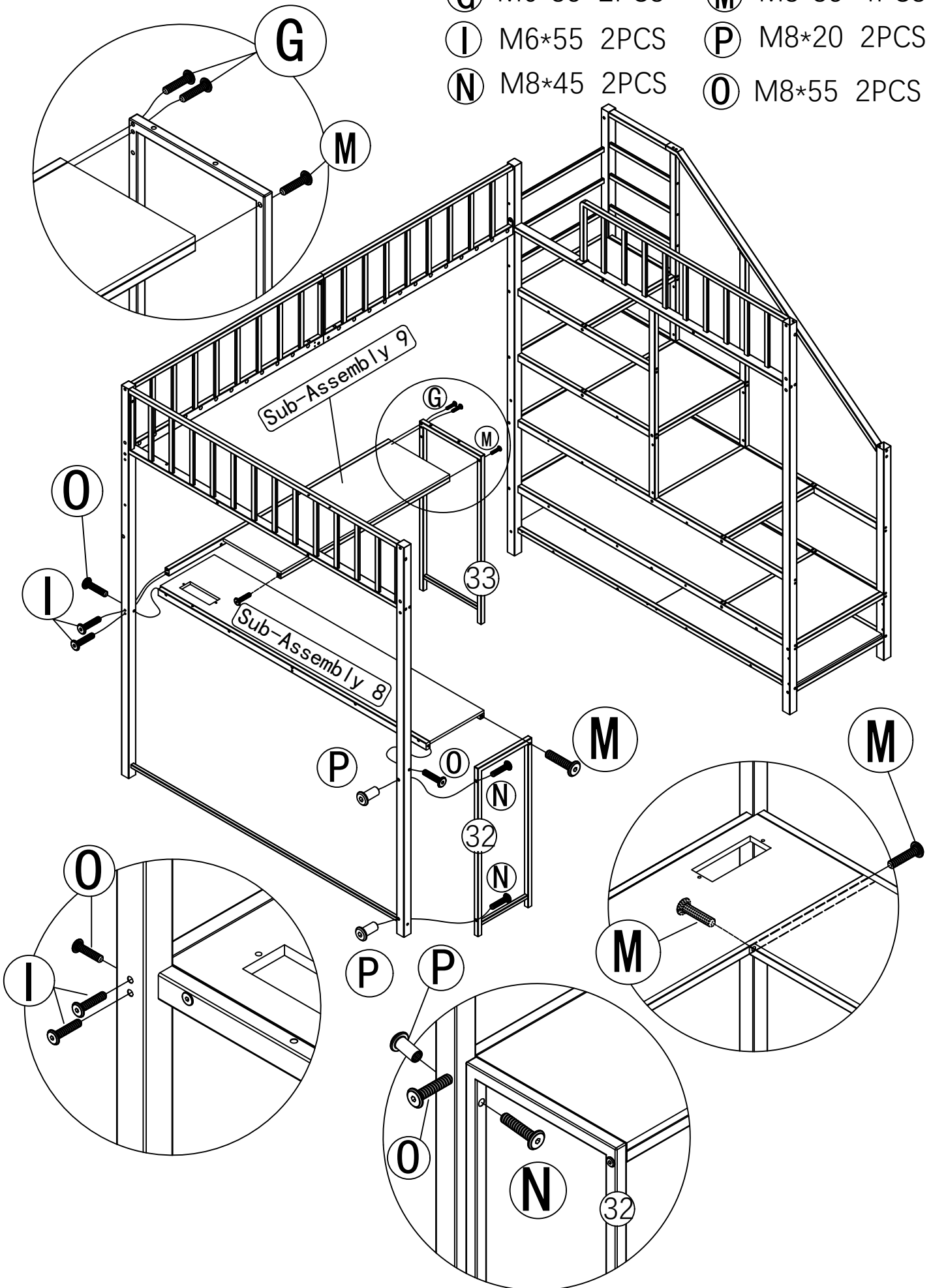

- ⓕ M6\*28 4PCS
- ⓖ M6\*35 5PCS
- Ⓢ M6\*55 4PCS
- Ⓤ M6\*20 1PCS

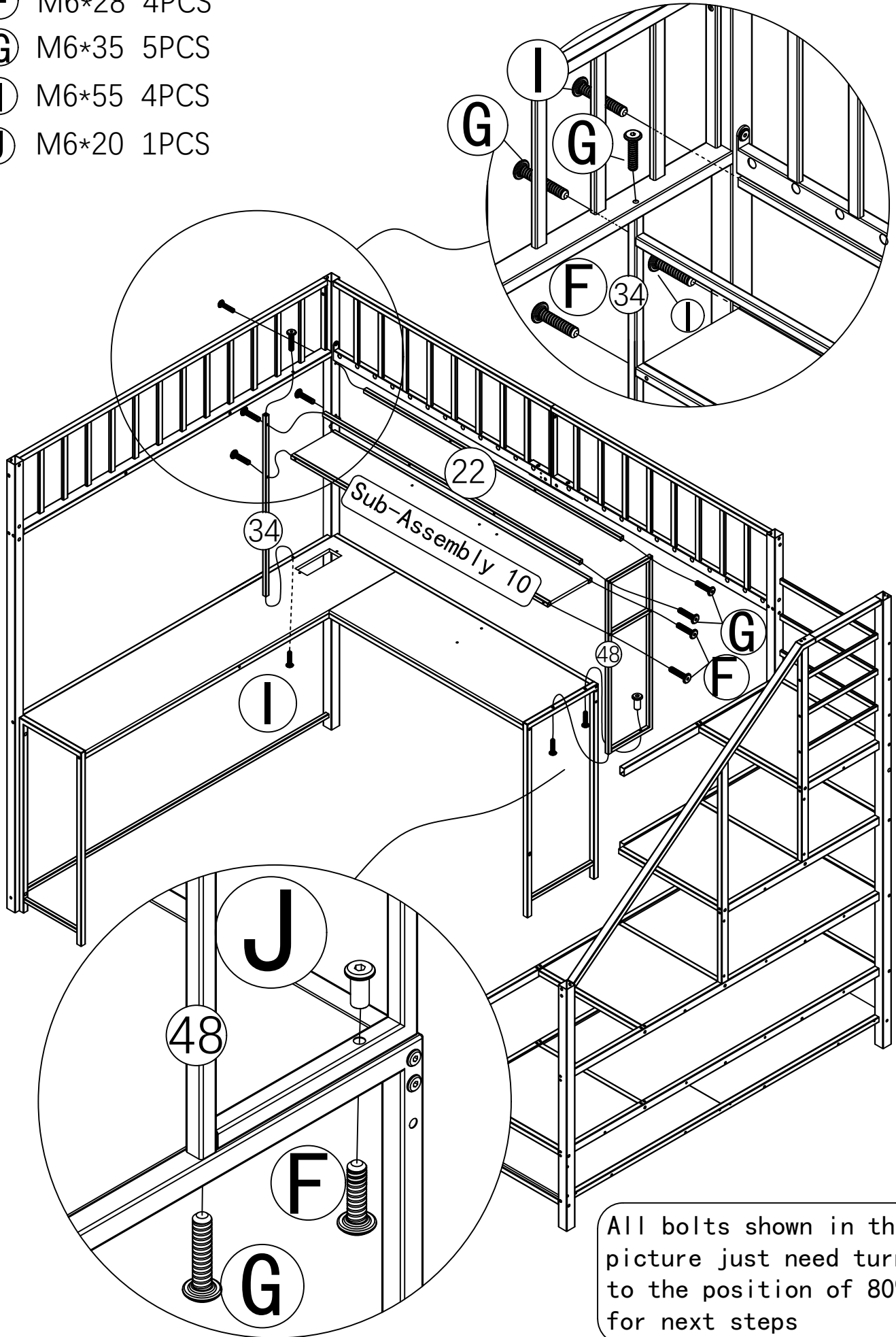

Ⓚ M3.5\*10 2PCS Ⓜ M5\*45 12PCS Ⓤ Ø9\*10 12PCS

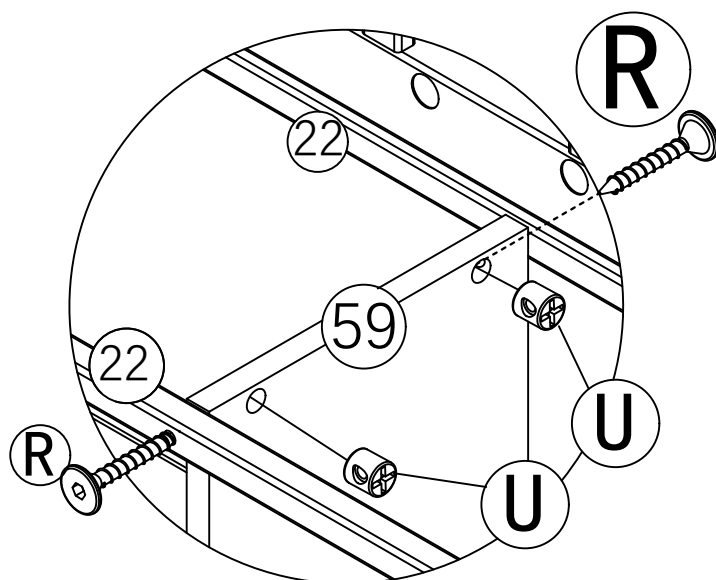
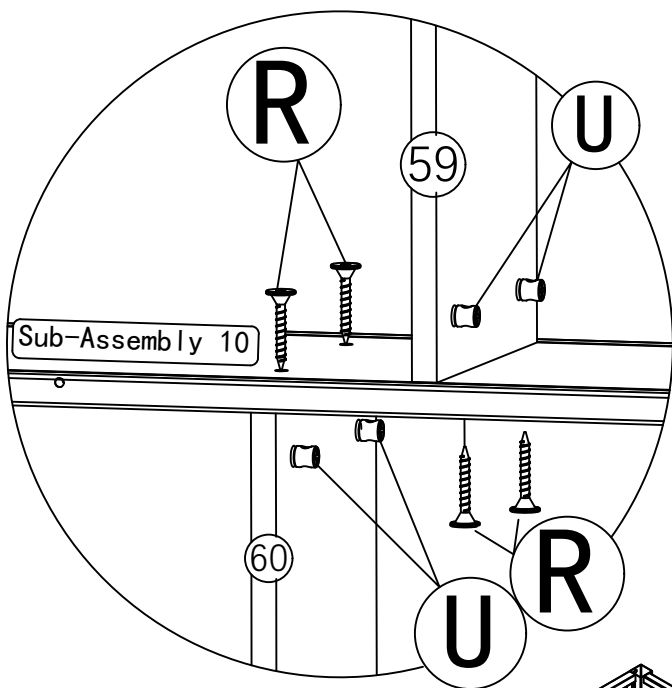

All bolts shown in the picture just need turn to the position of 80% for next steps

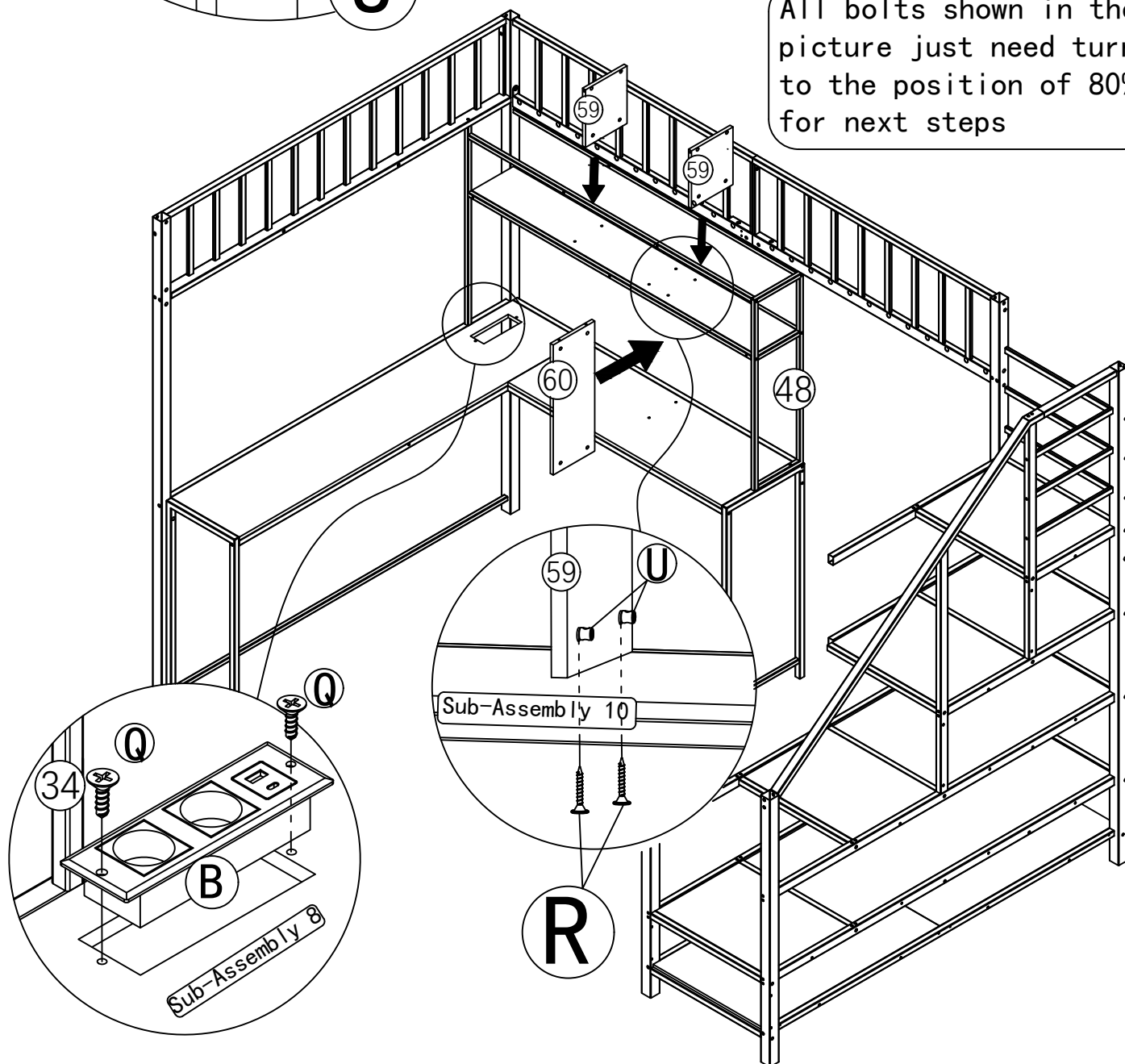

Ⓛ M8\*16 4PCS

Ⓜ M8\*35 3PCS

ⓐ M8\*55 5PCS

Ⓟ M8\*20 4PCS

All bolts shown in the picture just need turn to the position of 80% for next steps

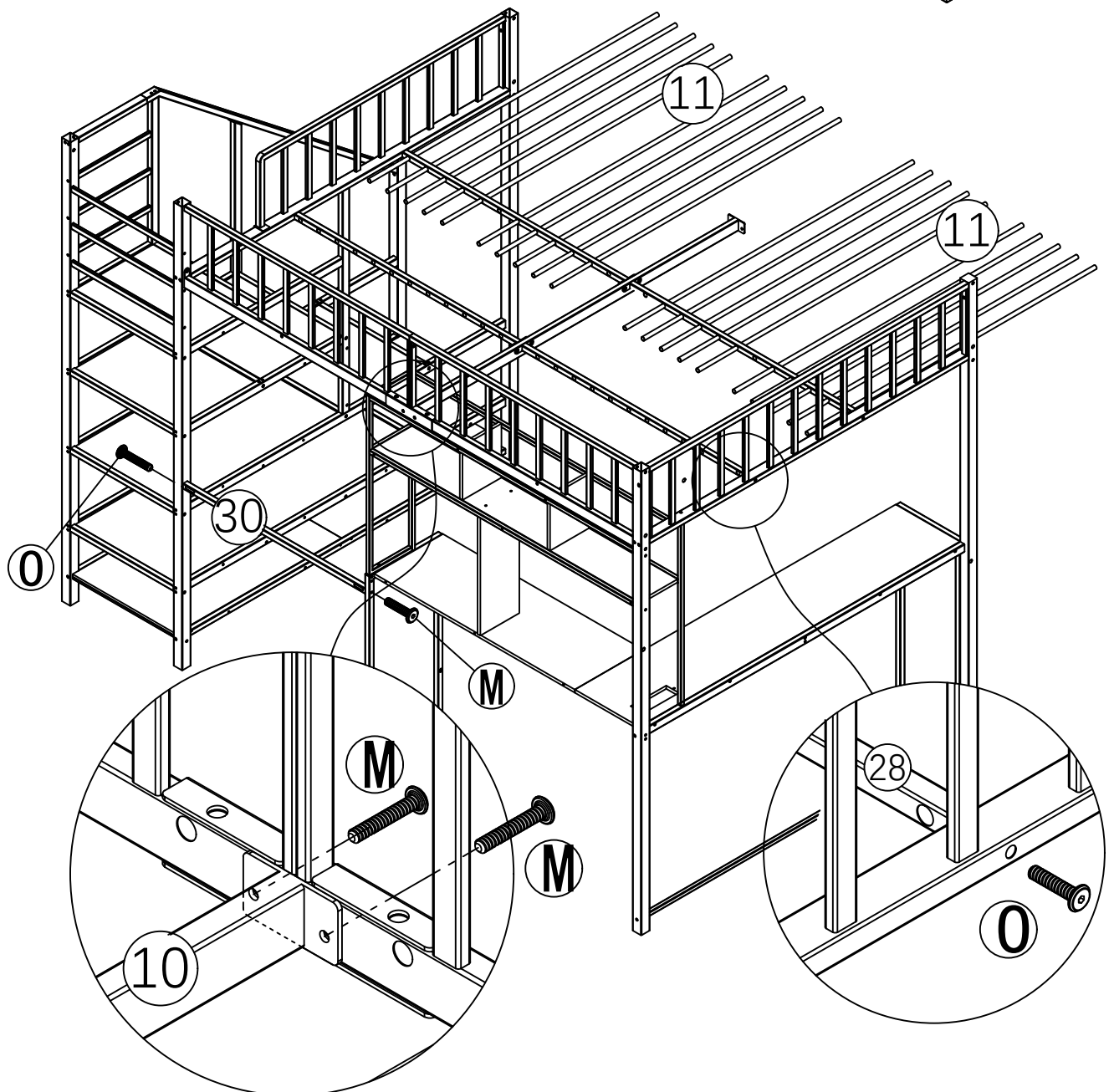
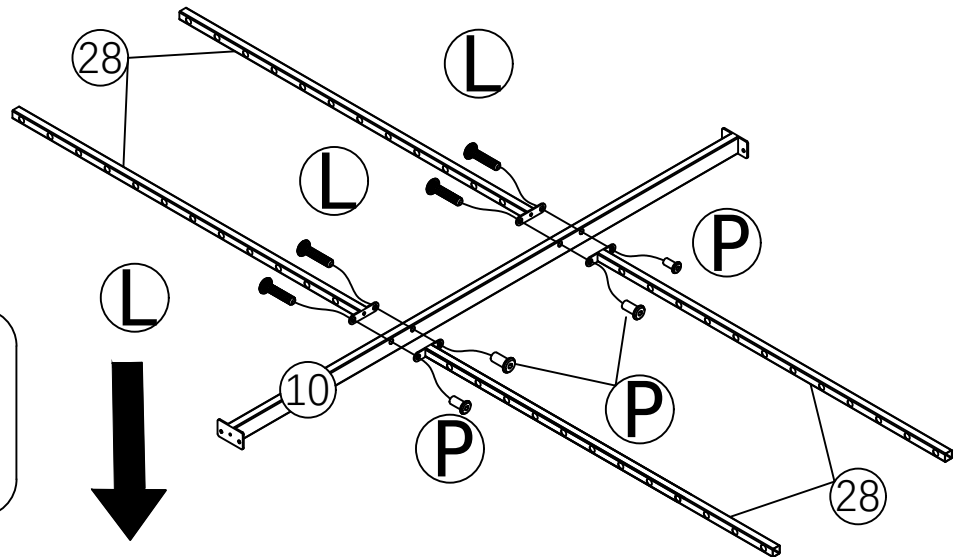

- (E)** M6\*20 8PCS
- (M)** M8\*35 6PCS
- (O)** M8\*55 4PCS
- (P)** M8\*20 2PCS

To ensure stability and safety, check all previously installed points and tighten all screws securely at this time.

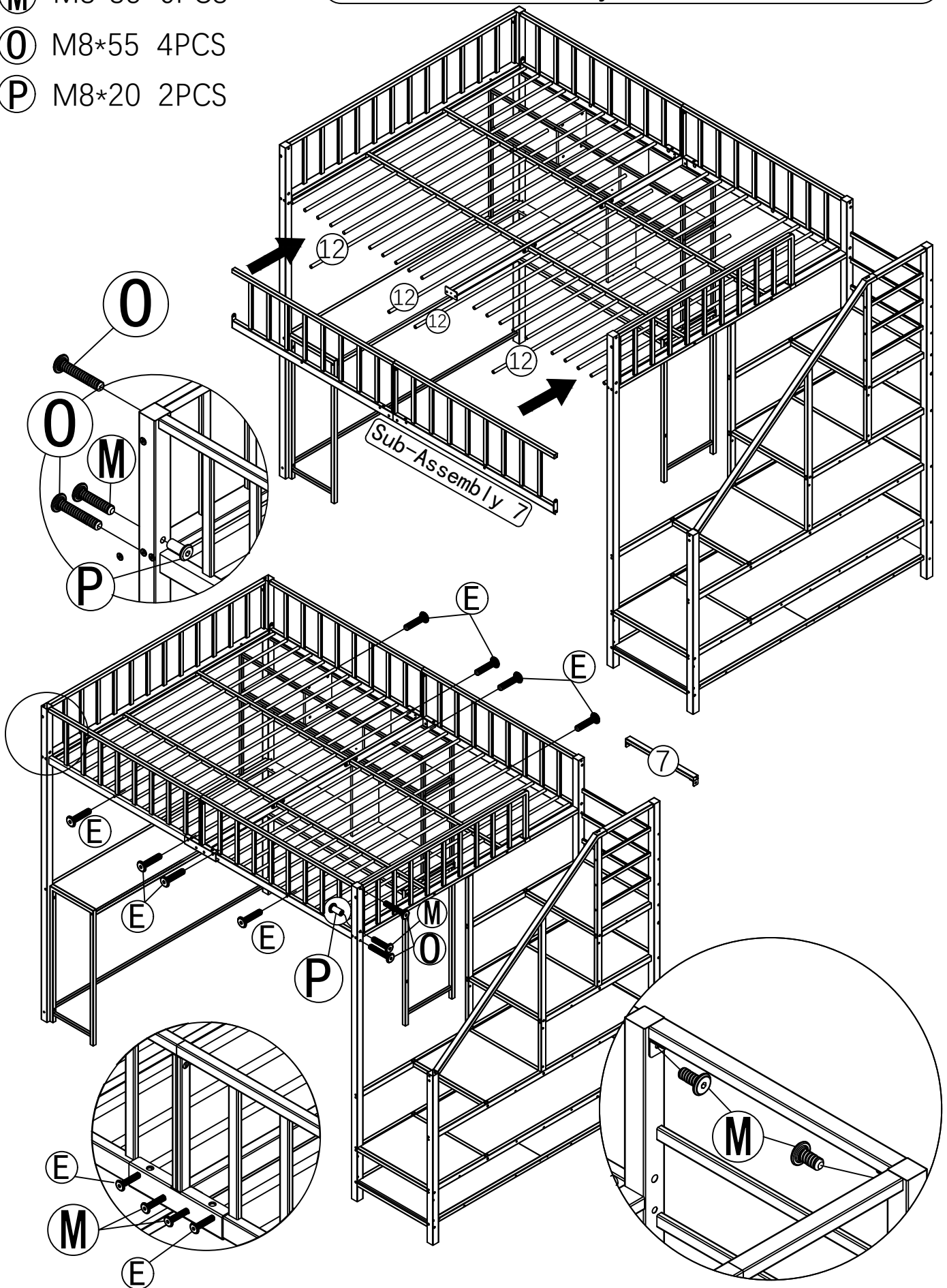

All bolts shown in the picture just need turn to the position of 80% for next steps

- D** M6\*10 2PCS
- E** M6\*20 14PCS
- G** M6\*35 6PCS
- H** M6\*45 4PCS
- O** M8\*55 2PCS
- Z** Leveling Glide 4PCS

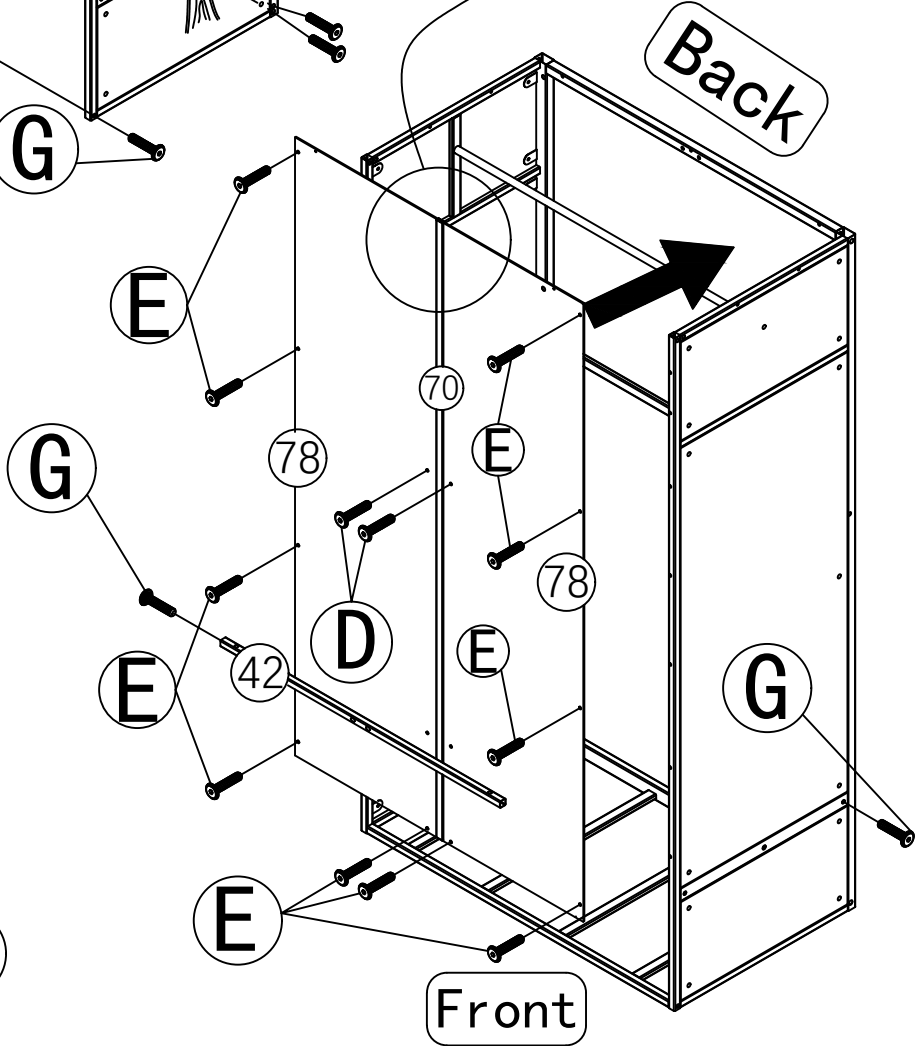
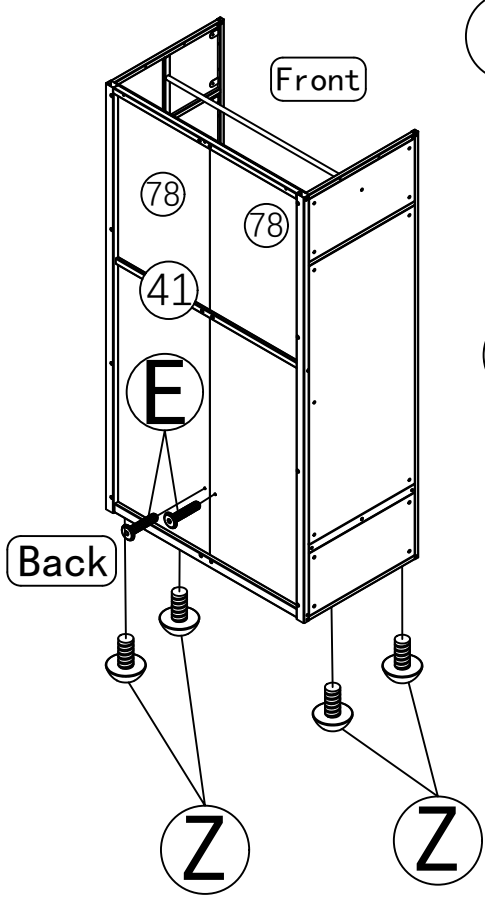
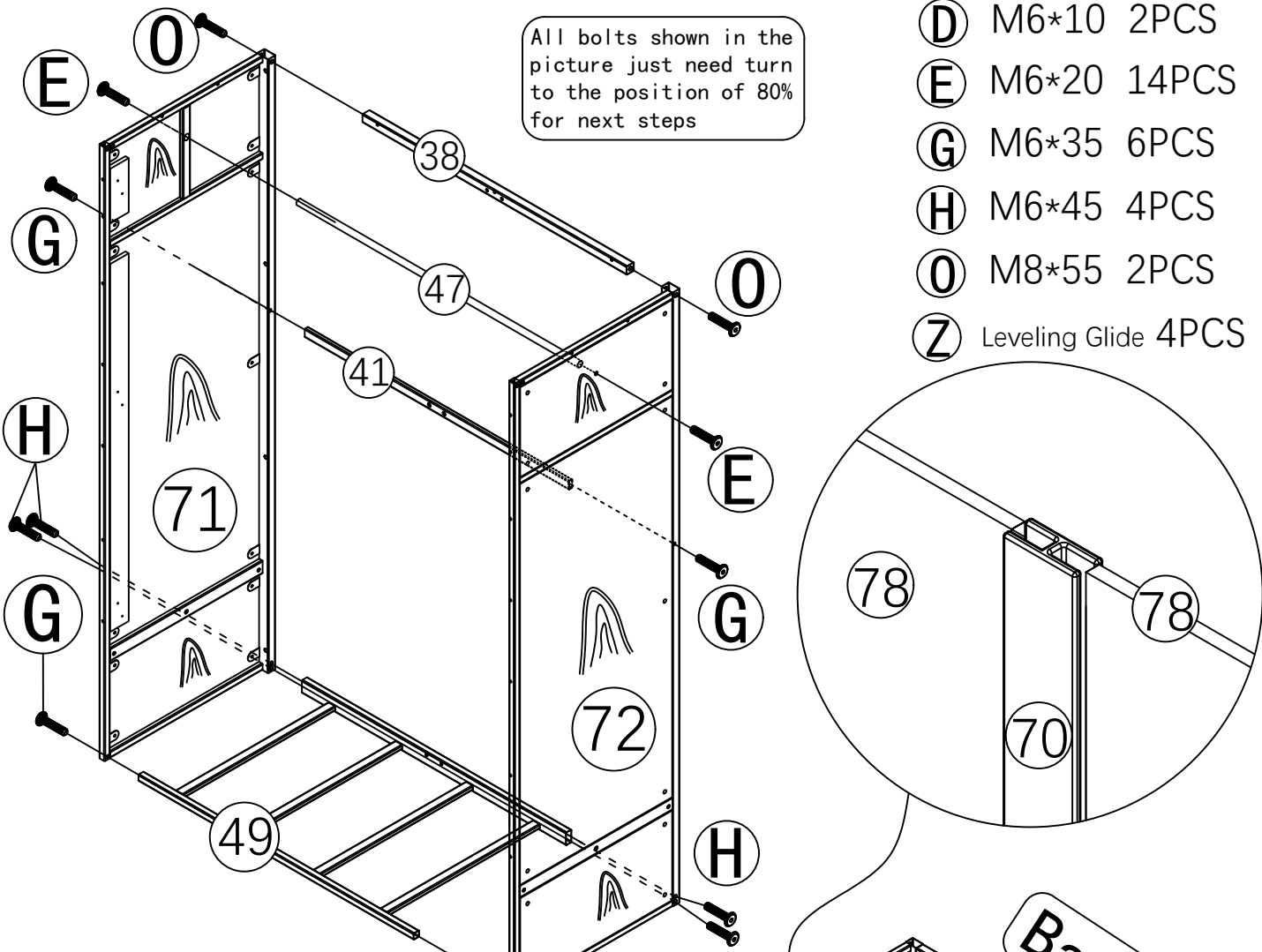



**T** M4\*50 3PCS      **G** M6\*35 6PCS

**H** M6\*45 4PCS

**E** M6\*20 6PCS

**S** M4\*40 7PCS

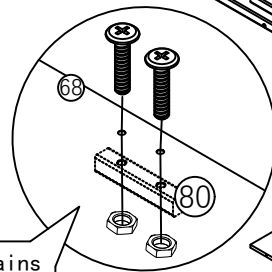
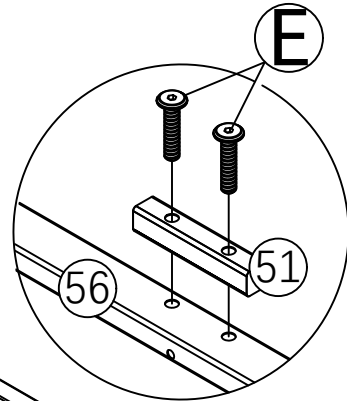
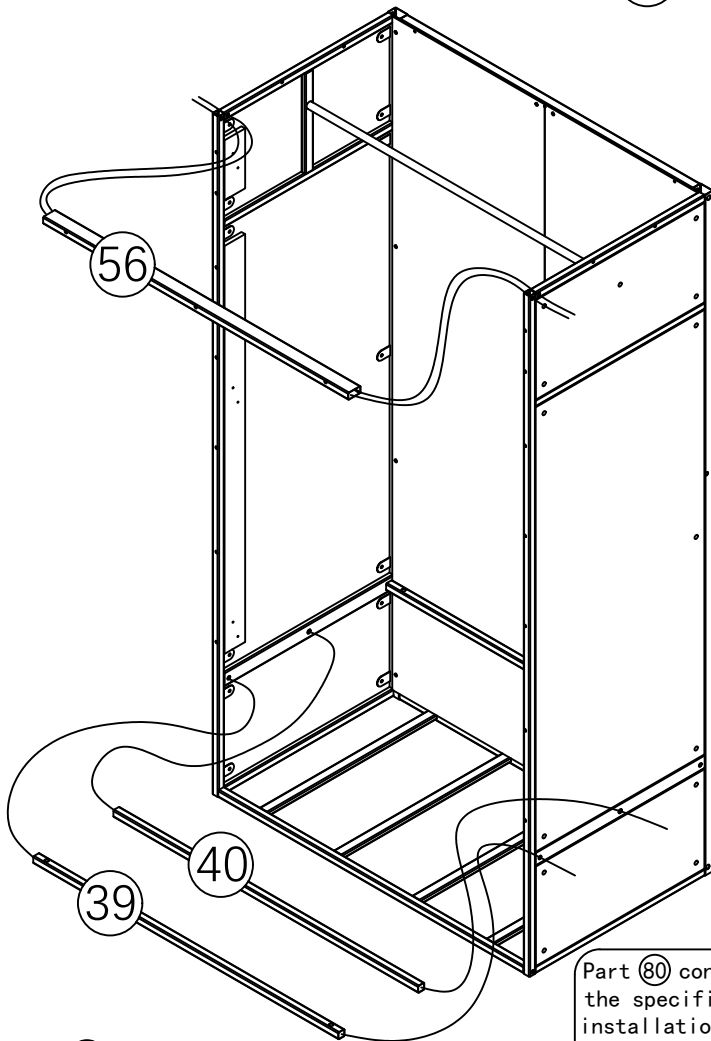

Install Part 80 below Part 68.

Part 80 contains the specific installation screws.

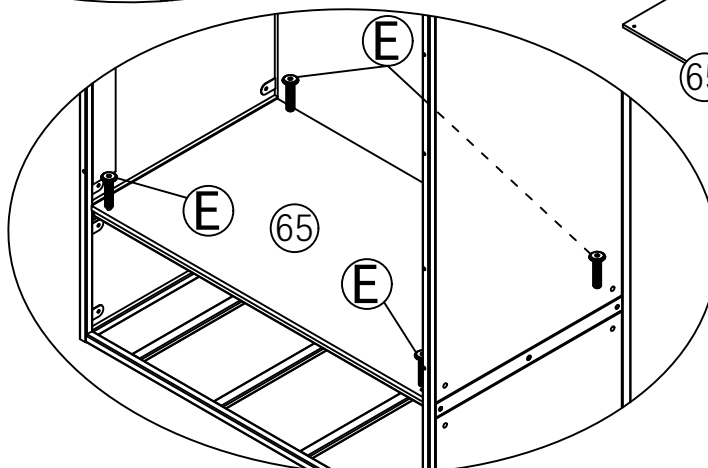
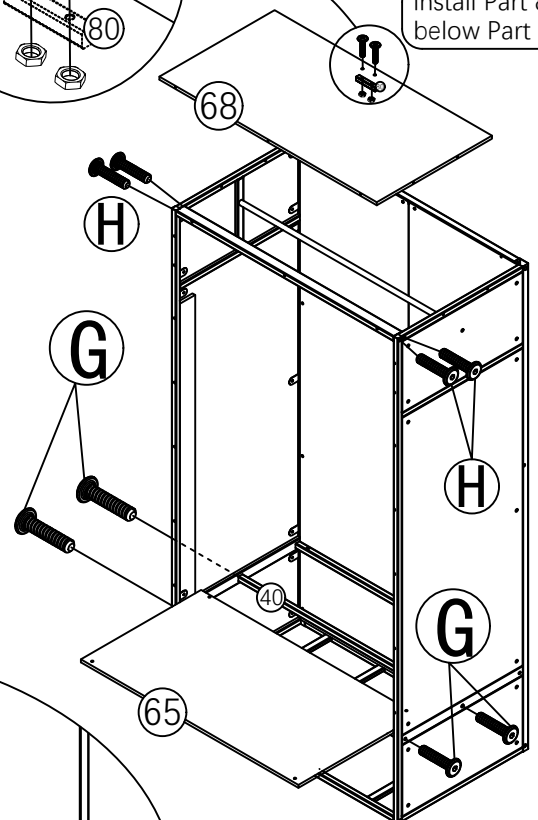
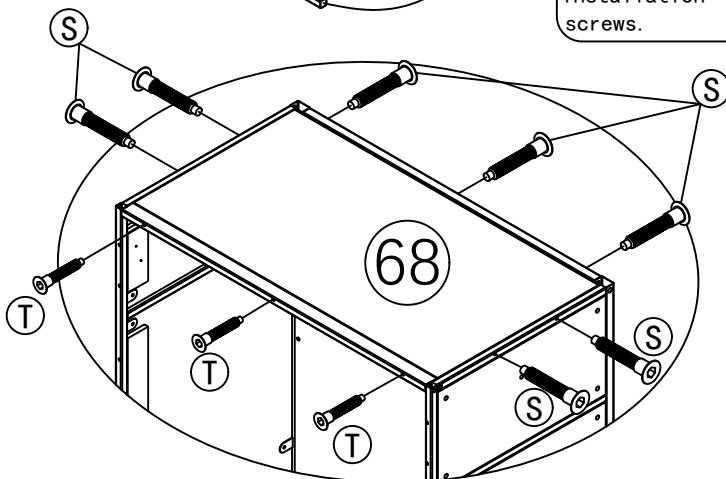

All bolts shown in the picture just need turn to the position of 80% for next steps

⊗ Cabinet Hinge 6 PCS

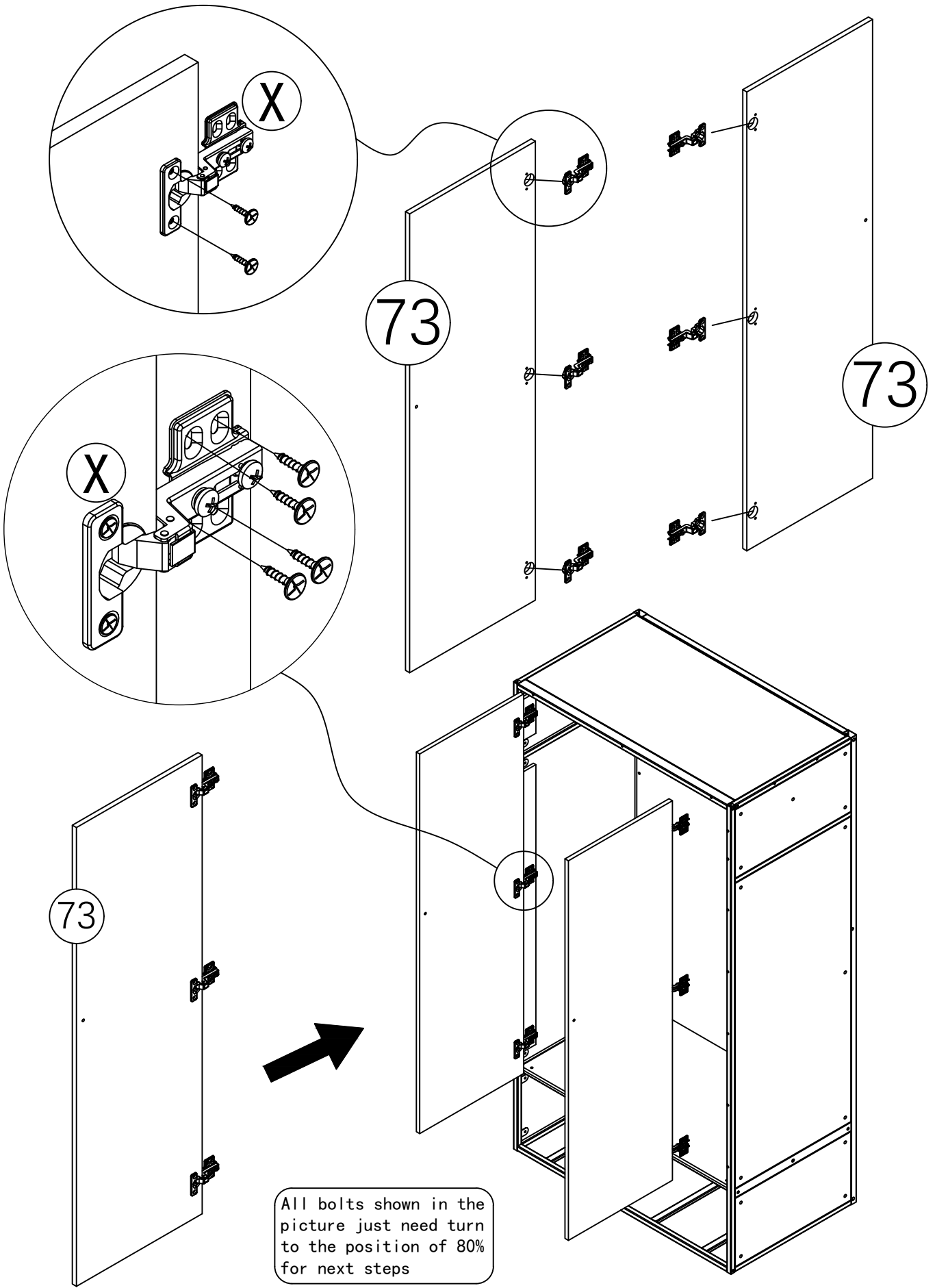

All bolts shown in the picture just need turn to the position of 80% for next steps

Ⓜ Knob 2 PCS   Ⓚ M4\*20 2PCS

ⓔ M6\*20 2PCS   Ⓥ Knob 1 PCS

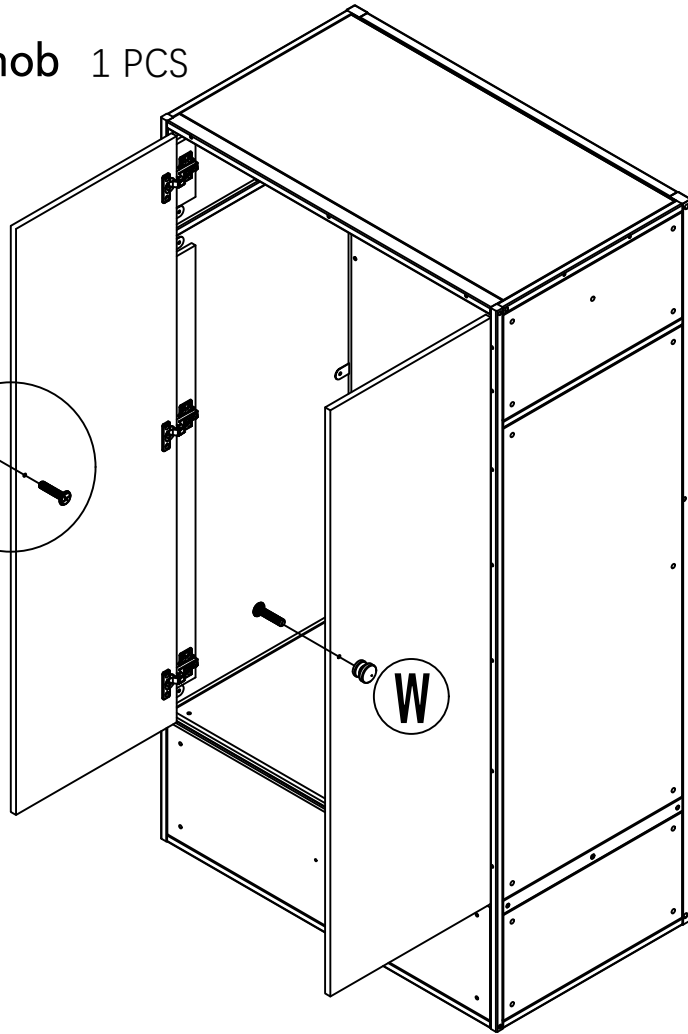
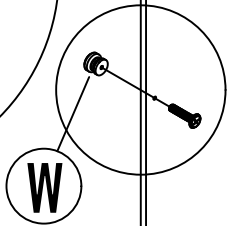
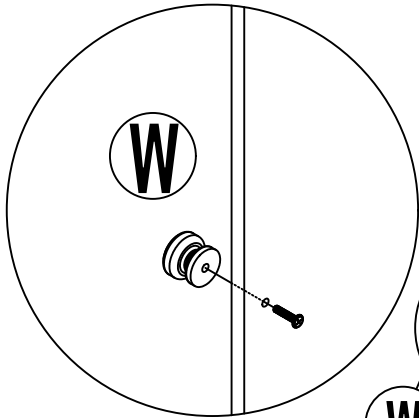

Part Ⓜ should be installed with the screws provided in the bag.

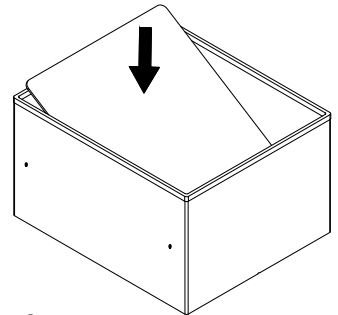
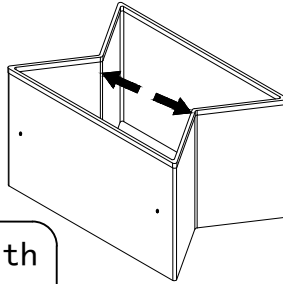
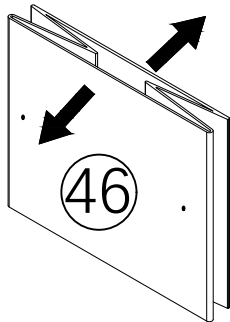

Part Ⓥ should be installed with the screws provided in the bag.

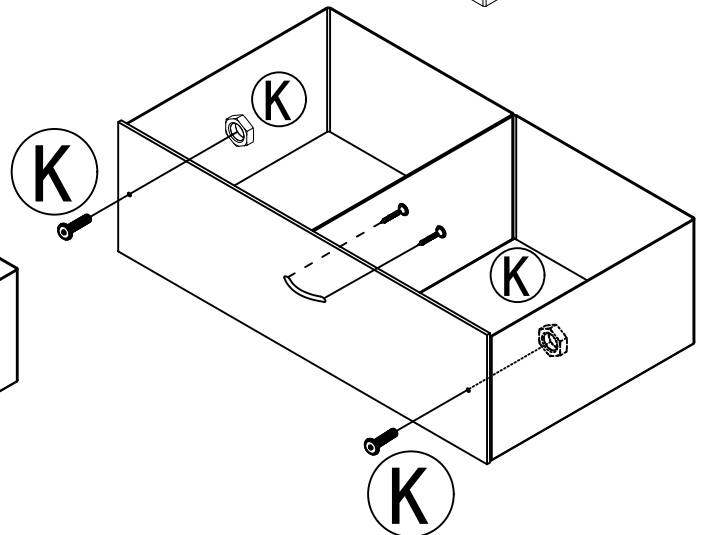
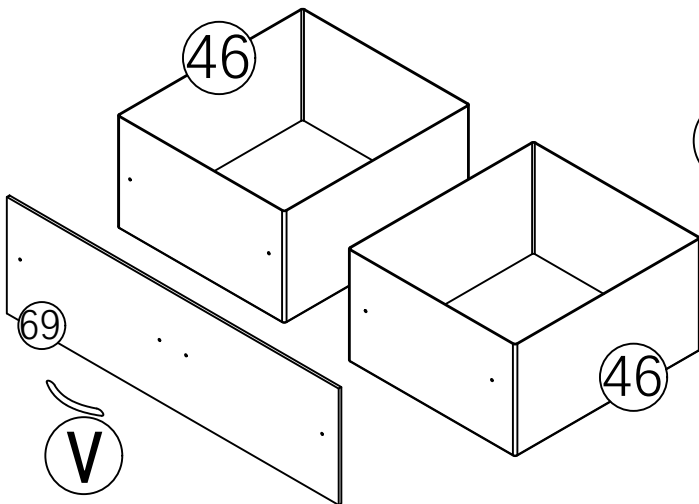

Ⓒ M6\*35 2PCS

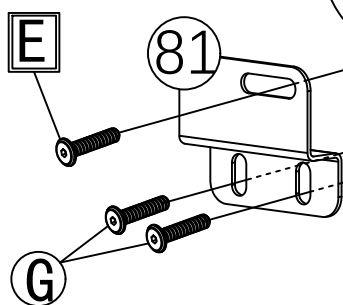
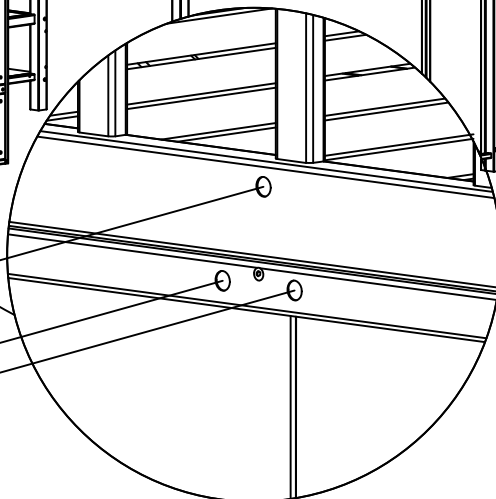
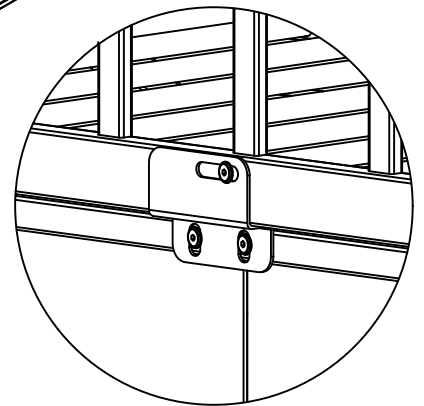
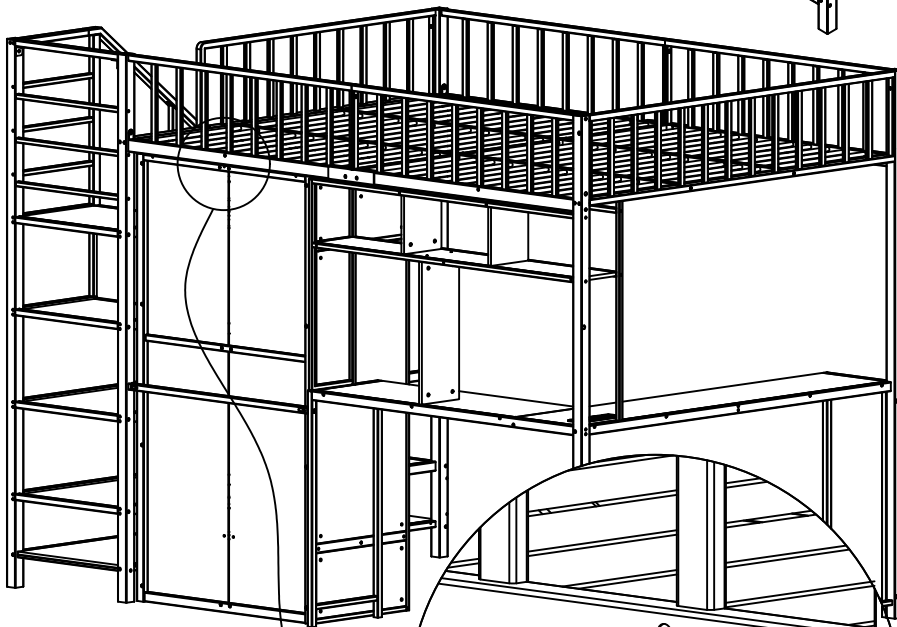
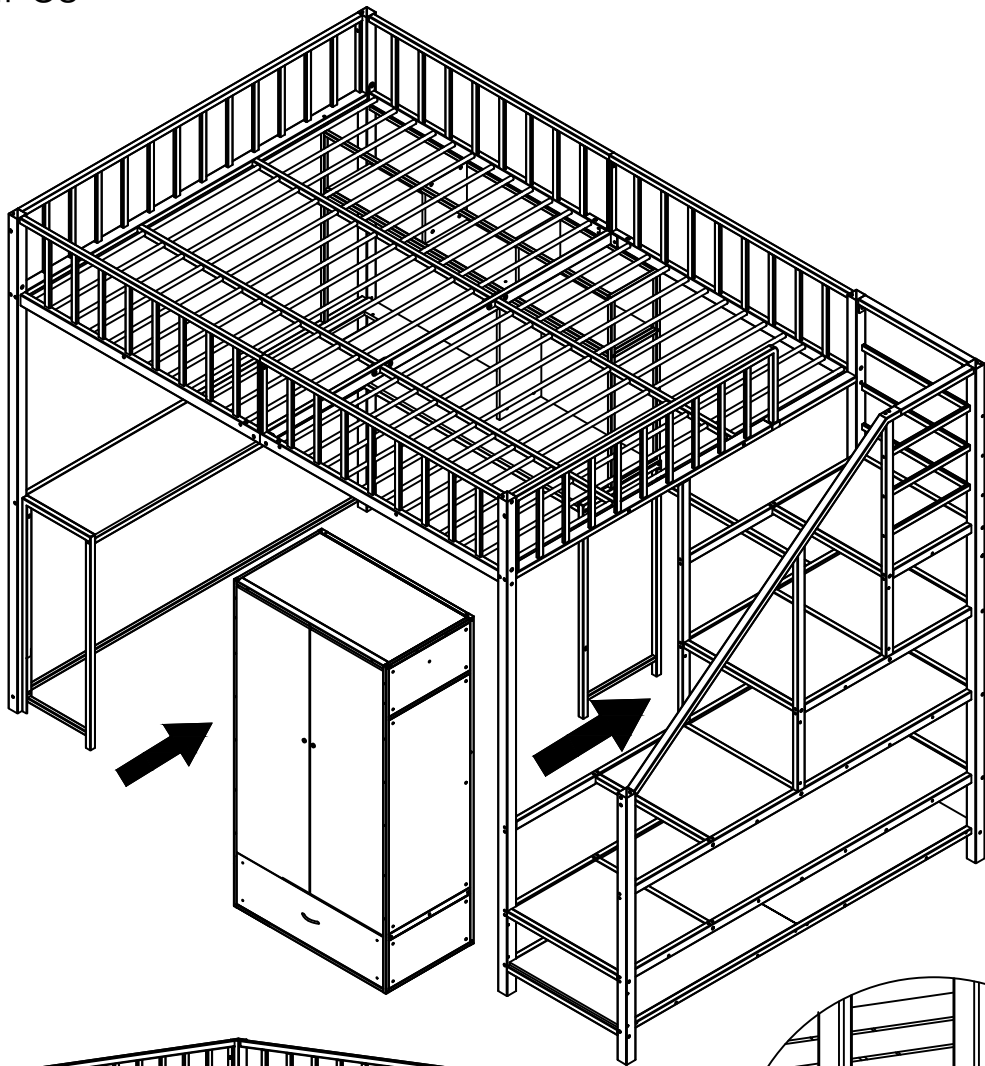

Remove the pre-installed Screw **E** and reuse it to secure Part **81**.

**M** M8\*35 2PCS    **Y** Wall Anchor 2 PCS

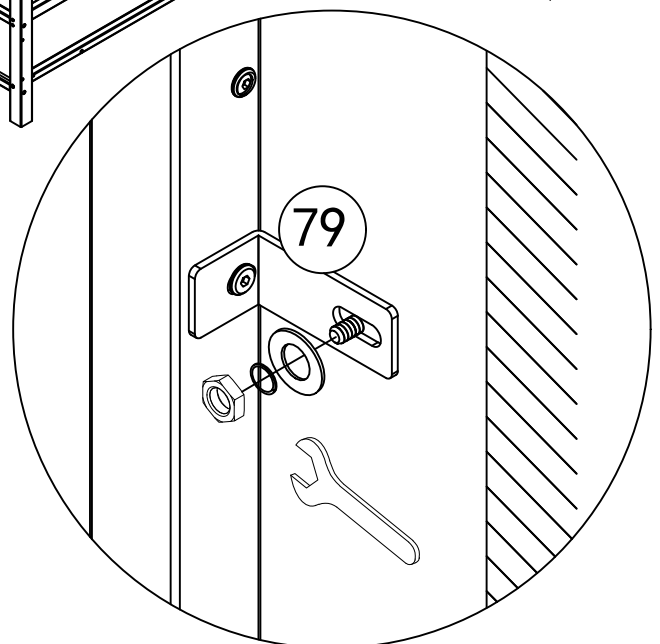
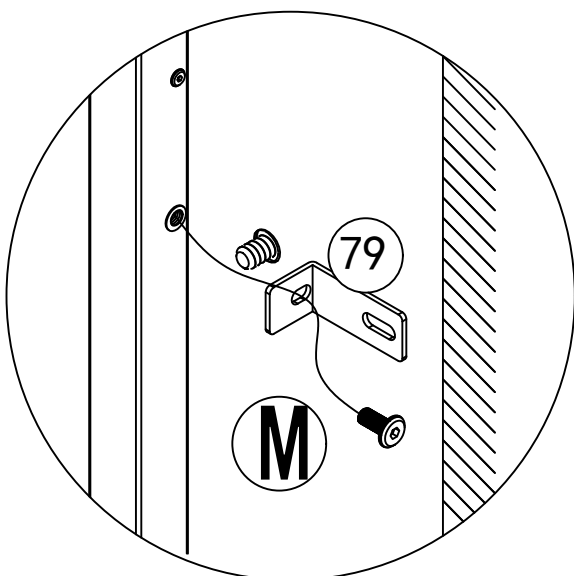
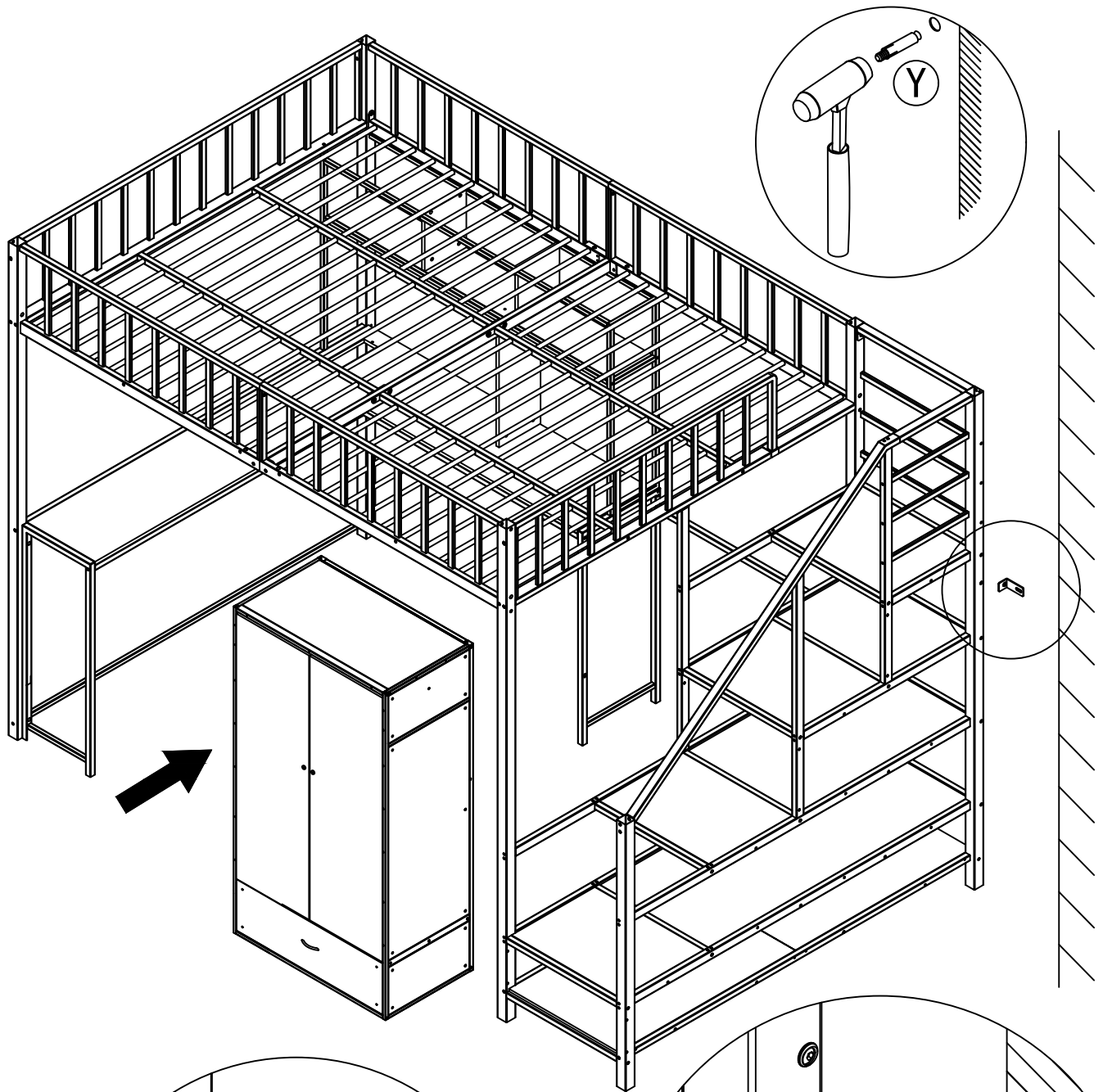

To ensure stability and safety, check all previously installed points and tighten all screws securely at this time.

To install the (A) LED light strip:  
You can simply utilize its adhesive backing to mount it on the recommended underside of the desk, considering your preference and cable length. The exact position is not fixed. Once placed, connect it to a USB power source.

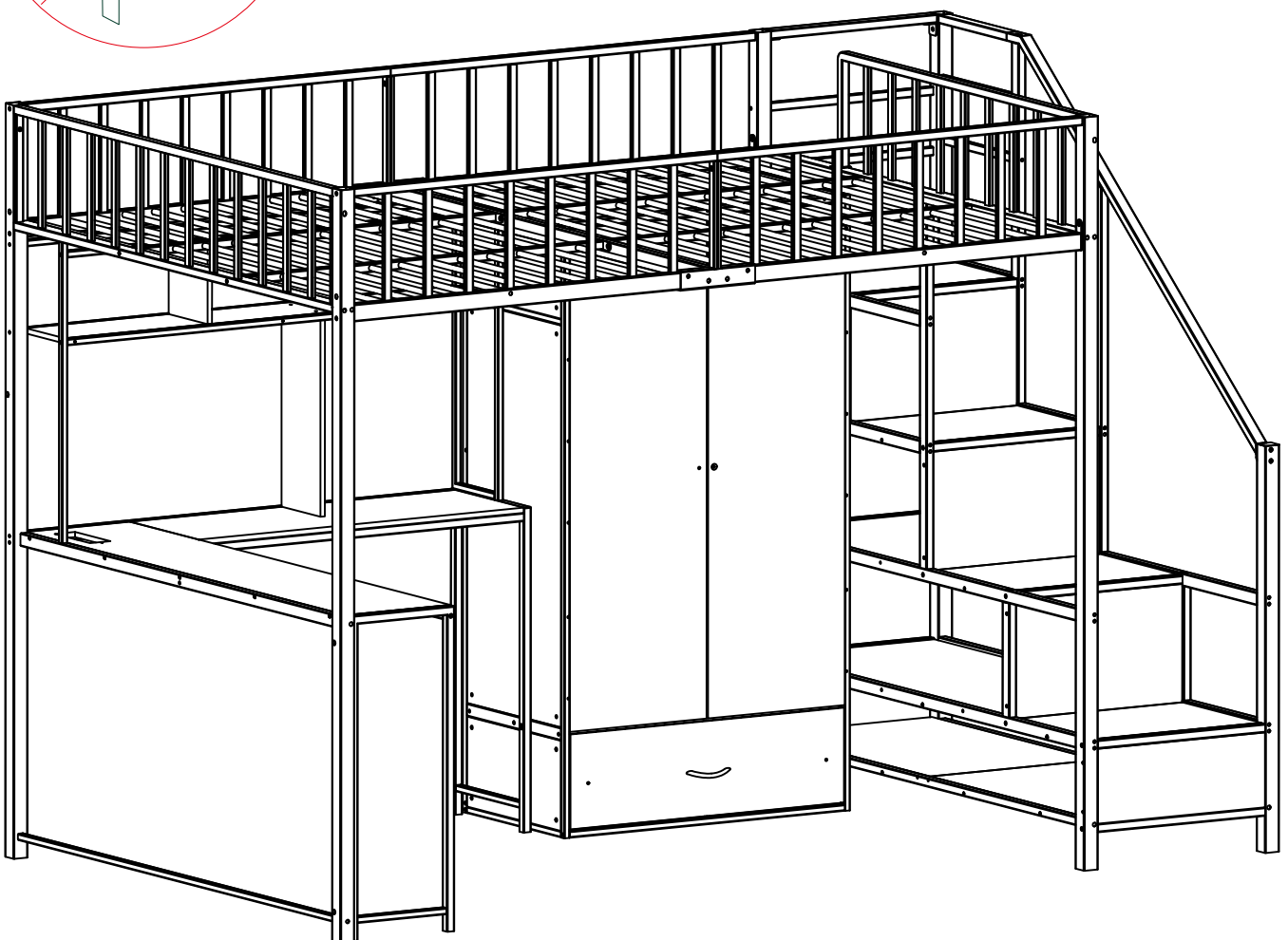



## Shenzhen Huaxi Testing Technology Co., Ltd.

406, Building C, Hongwan Business Center, Hongwan Second Industrial Zone, No. 4227

Bao'an Avenue, Gushu Community, Xixiang Street, Bao'an District, Shenzhen City

Tel: +0755-23087154

Email: huaxitest@163.com

Web: www.hxjc-lab.cn

# CERTIFICATE OF CONFORMITY

No.: HX-250901030585

**Applicant** : Jiangxi Jifa Technology Co., Ltd.  
**Address** : 50 meters south of Jinshan Avenue, South of Yu Industrial Park, Huangbu Town, Shanghu County, Ganzhou City, Jiangxi Province, China  
**Manufacturer** : Jiangxi Jifa Technology Co., Ltd.  
**Address** : 50 meters south of Jinshan Avenue, South of Yu Industrial Park, Huangbu Town, Shanghu County, Ganzhou City, Jiangxi Province, China  
**Product** : LED Strip Light  
**Brand Name** : N/A  
**Model(s)** : 5050-30D-5V-RGB

Essential requirement	Standards	Documentary Evidence	Result
EMC	ETSI EN 301 489	HX-250901030585	Pass
Radio	ETSI EN 300 328	HX-250901030586	Pass
Health	EN 62479: 2010	HX-250901030587	Pass
LVD	EN IEC 62368	HX-250901030588	Pass

The EUT described above has been tested by us with the listed standards and found in compliance with the Council RED Directive 2014/53/EU. It is possible to use CE marking to demonstrate the compliance with this RED Directive.

The certificate applies to the tested sample above mentioned ~~only~~ and shall not imply an assessment of the whole production.



2025-09-04

# Certificate of Conformity

No.: LP24060215C01-01

The following products have been tested by us with the listed standards and found in compliance with the council EMC directive 2014/30/EU. It is demonstrative for the compliance with this EMC Directive.

**Applicant** : Dongguan Baiyou Electronic Co.,Ltd  
**Address** : 2F A Building Wufeng Industrial, Jintan Road, Shijie Town  
523290 Dongguan City PEOPLE'S REPUBLIC OF CHINA  
**Product** : Strip power supply  
**Model No.** : BAYU--SKCE-901, BAYU--SKCE-902, BAYU--SKCE-903,  
BAYU--SKCE-906, BAYU--SKCE-907, BAYU--SKCE-908,  
BAYU--SKCE-901A, BAYU--SKCE-902A, BAYU--SKCE-903A,  
BAYU-AE02AC0523, BAYU-AE02AC0524, BAYU-AE02AC0525  
**Test Standards** : EN 55032:2015+A11:2020+A1:2020  
EN 55035:2017+A11:2020  
EN IEC 61000-3-2:2019+A1:2021  
EN 61000-3-3:2013+A1:2019+A2:2021



The CE marking may be used if all relevant and effective EC Directives/Regulations are complied with.

  
Manager: Frank Shen  
Date: October 31, 2025

**Dongguan Lepont Testing Service Co., Ltd.**

Tel.:86-769-83086888 Fax.:86-769-83096886

Room 102, Building 11, No.7, Houjie Science And Technology Avenue, Houjie, Dongguan,  
Guangdong, China

The statement is based on a single evaluation of one sample of above mentioned products. It does not imply an assessment of the whole production and does not permit the use of the test lab's logo.