

Assembly Checklist

Please make sure that you have all of the below items before you start. If any are missing, please contact Zijlstra BV for a replacement.

Parts supplied for assembly

PART LIST		QTY
1	ROUND TOP	1
2	Iron Leg	4

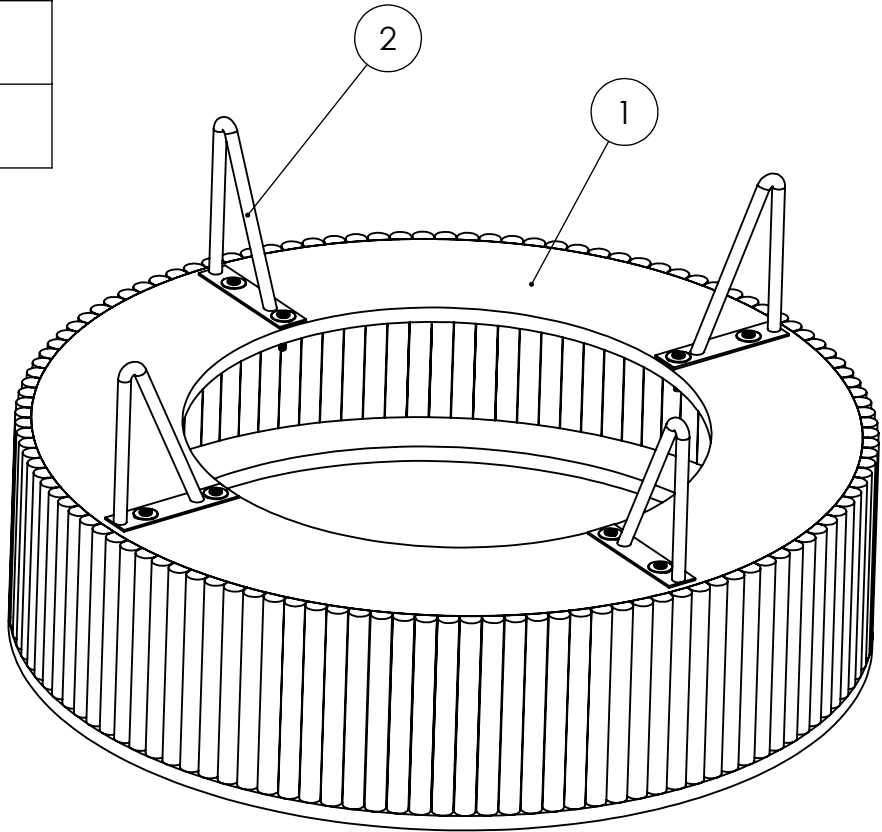

Hardware supplied for assembly

HARDWARE LIST		QTY
A	ALLEN BOLT M8X25mm	8
B	WASHER M8	8
C	ALLEN KEY	1

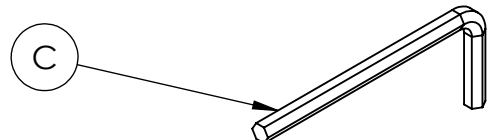
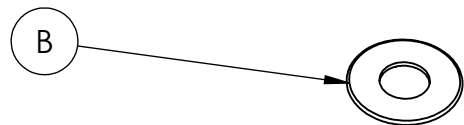
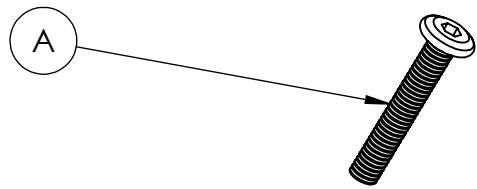

Step 1

Note: Skipping any steps could lead to improper assembly and damages.

-Attach Part (1) with Part (2).

Then Insert hardware allen bolt (A) with washer(B) and Tight allen bolt (A) and washer (B) using hardware allen key (C)

Apply Step 1 for all Remaining Leg.

Note : Make sure that mentioned number should be match stick on parts.

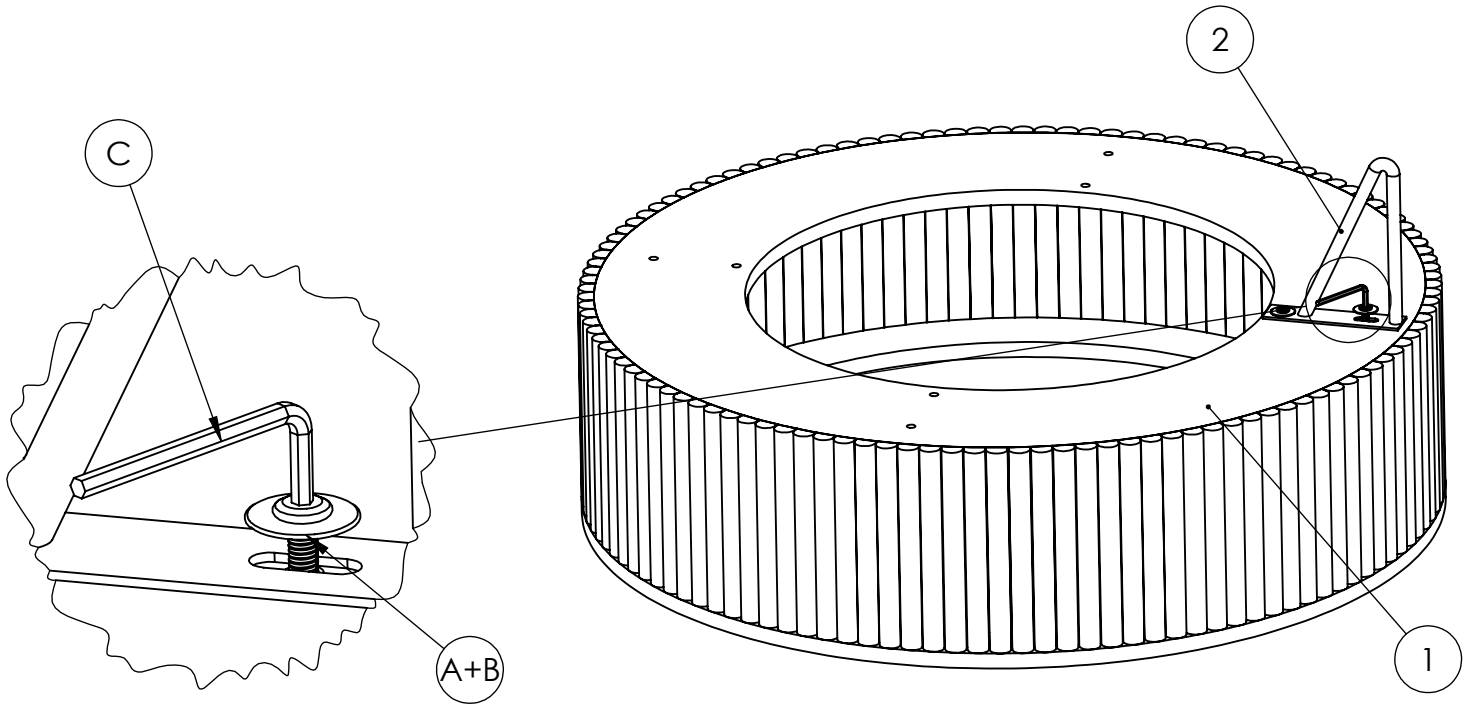

FINAL PRODUCT

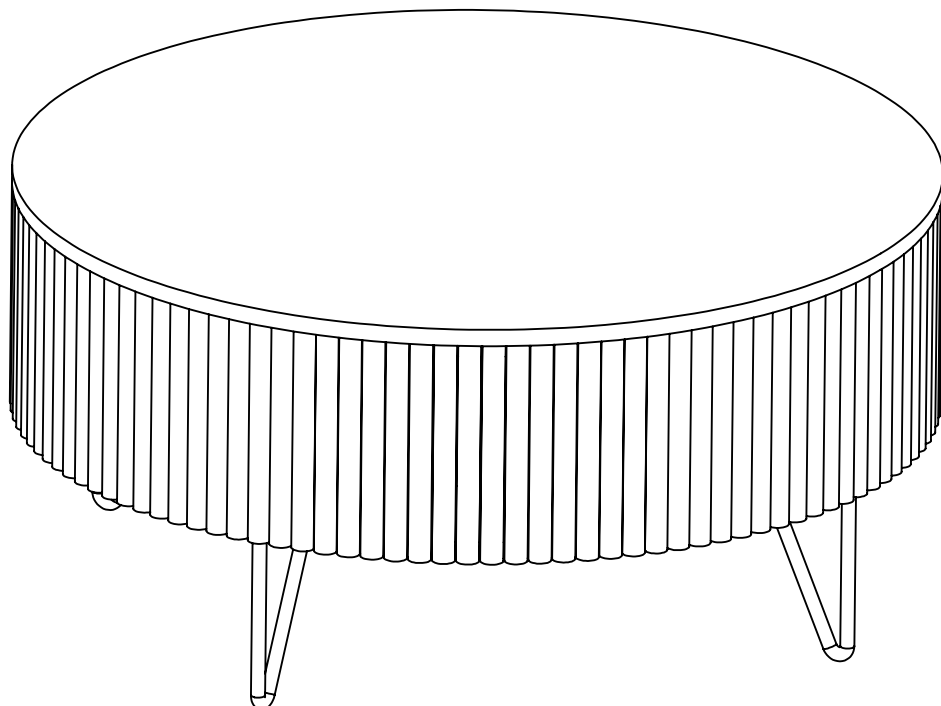

Care and Maintenance

1. For General cleaning use a dry cloth do not use wet cloth, soap, detergent, aerosol sprays and polish on the product.
2. Do Not place hot or cold items directly on the surface. Use of Placement is recommended to avoid marks.
3. This Product is manufactured in solid hardwood and is made for indoor use