

Installationsanleitung
Installation Instruction
Instruction d'installation



Unser Produkt wird Ihnen in 3 Paketen geliefert. Die Lieferzeiten dieser 3 Pakete können abweichen, bitte haben Sie etwas Geduld und vielen Dank für Ihr Verständnis.

Our product will be delivered to you in 3 packages. The delivery times of these 3 packages may differ, please be patient and thank you for your understanding.

Notre produit vous sera livré en 3 colis. Les délais de livraison de ces 3 colis peuvent différer, soyez patient et merci pour votre compréhension.

N636P335094 N636P335095 N636P335096

English

IMPORTANT ! KEEP FOR FUTURE REFERENCE : READ CAREFULLY

- To be assembled by an adult. Assembly must be checked by an adult before use
- **WARNING!** Keep all screws, small parts and plastic bags out of the reach of children
- Properly identify all parts before assembling
- Never use your item if any of its parts are broken or missing
- Should any problems arise, please contact our After Sales Service
- Manufacturer's instructions shall be followed at all times
- Care: Clean with a soft, dry cloth. In case of larger stains, carefully rub with a slightly damp, non- abrasive sponge
- Avoid the risk of fire by not placing furniture near sources of ignition or hot items
- Do not jump on the bed

Deutsch

WICHTIG! ZUM SPÄTEREN NACHSCHLAGEN AUFBEWAHREN: SORGFÄLTIG LESEN

- Muss von einem Erwachsenen zusammengebaut werden. Der Zusammenbau muss vor dem Gebrauch von einem Erwachsenen überprüft werden
- **WARNUNG!** Bewahren Sie alle Schrauben, Kleinteile und Plastikbeutel außerhalb der Reichweite von Kindern auf
- Kennzeichnen Sie vor dem Zusammenbau alle Teile richtig
- Benutzen Sie Ihren Artikel niemals, wenn Teile gebrochen sind oder fehlen
- Sollten Probleme auftreten, wenden Sie sich bitte an unseren Kundendienst
- Die Anweisungen des Herstellers sind stets zu befolgen
- Pflege: Mit einem weichen, trockenen Tuch reinigen. Bei größeren Flecken vorsichtig mit einem leicht feuchten, nicht scheuernden Schwamm abreiben. nicht scheuernden Schwamm
- Vermeiden Sie die Gefahr eines Brandes, indem Sie die Möbel nicht in der Nähe von Zündquellen oder heißen Gegenständen aufstellen
- Nicht auf das Bett springen

Français

IMPORTANT! CONSERVER POUR RÉFÉRENCE ULTÉRIEURE: LIRE ATTENTIVEMENT

- Le montage doit être effectué par un adulte. Le montage doit être vérifié par un adulte avant utilisation
- **ATTENTION!** Tenir les vis, les petites pièces et les sachets en plastique hors de portée des enfants
- Identifiez correctement toutes les pièces avant de les assembler
- N'utilisez jamais votre article si l'une de ses pièces est cassée ou manquante
- En cas de problème, veuillez contacter notre service après-vente
- Les instructions du fabricant doivent être respectées à tout moment
- Entretien: nettoyer avec un chiffon doux et sec. En cas de taches plus importantes, frotter soigneusement avec une éponge non abrasive légèrement humide. légèrement humide et non abrasive
- Évitez les risques d'incendie en ne plaçant pas les meubles à proximité de sources d'inflammation ou d'objets chauds
- Ne pas sauter sur le lit

- Deve essere assemblato da un adulto. L'assemblaggio deve essere controllato da un adulto prima dell'uso
- **ATTENZIONE!** Tenere tutte le viti, le piccole parti e i sacchetti di plastica fuori dalla portata dei bambini
- Identificare correttamente tutte le parti prima dell'assemblaggio
- Non utilizzare mai l'articolo se alcune parti sono rotte o mancanti
- In caso di problemi, si prega di contattare il nostro Servizio Post Vendita
- Le istruzioni del produttore devono essere sempre seguite
- Cura: Pulire con un panno morbido e asciutto. In caso di macchie più estese, strofinare accuratamente con una spugna leggermente umida e nonspugna leggermente umida e non abrasiva
- Evitare il rischio di incendio, non collocando i mobili vicino a fonti di accensione o a oggetti caldi
- Non saltare sul letto

- Debe ser montado por un adulto. El montaje debe ser comprobado por un adulto antes del uso
- **ADVERTENCIA** Mantenga todos los tornillos, piezas pequeñas y bolsas de plástico fuera del alcance de los niños
- Identifique correctamente todas las piezas antes de montarlas
- Nunca utilice su artículo si alguna de sus piezas está rota o falta
- Si surge algún problema, póngase en contacto con nuestro Servicio Postventa
- Las instrucciones del fabricante deben seguirse en todo momento
- Cuidado: Limpiar con un paño suave y seco. En caso de manchas más grandes, frote cuidadosamente con una esponja no abrasiva ligeramente humedecida
- Evite el riesgo de incendio no colocando los muebles cerca de fuentes de ignición u objetos calientes
- No saltar sobre la cama

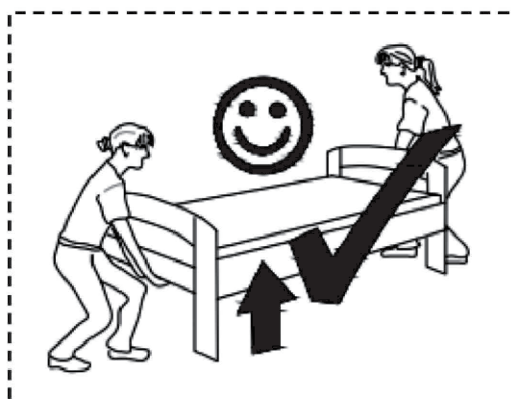
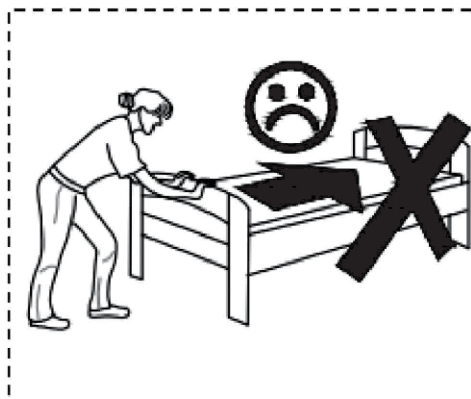













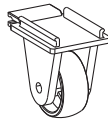

Vor dem Einbau die Schrauben in die Löcher stecken und festziehen, aber nicht bis 100%, 70% bis 80% anziehen reicht aus. Schließlich, nachdem alle Schrauben installiert sind, ziehen Sie alle Schrauben auf 100%. Wenn Sie auf diese Probleme stoßen, wie z. B. Fehlausrichtung der Löcher oder Unfähigkeit, bestimmte Teile zu installieren, überprüfen Sie bitte, ob die Schrauben korrekt verwendet werden und passen Sie die Dichtigkeit der Schrauben an.

Before installation, insert the screws into the holes and tighten them, but do not tighten them to 100%, 70% to 80% is sufficient. Finally, after all screws are installed, tighten all screws to 100%. If you encounter these issues, such as if the holes cannot be aligned or some parts cannot be installed, please check if the screws are used correctly and adjust the tightness of the screws.

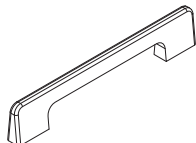
Insérer la vis dans le trou avant la fin de l'assemblage, serrer la vis, mais ne pas serrer à 100%, 70% ~ 80% est correct. Enfin, une fois que toutes les vis sont bien serrées, toutes les vis sont serrées à 100%. Si vous rencontrez ces problèmes, par exemple si les trous ne sont pas alignés ou si certaines pièces ne peuvent pas être montées, vérifiez que les vis sont utilisées correctement et Ajustez leur serrage.

Hardware List For N636P335095

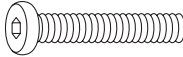
 M6 x 12mm A x 85	 M8 x 12mm B x 4	 M6 x 35mm C x 16	 M6 x 45mm D x 2	 M8 x 55mm E x 6	 M6 x 10mm F x 4
 Ø4x12mm G x 2	 H x 5	 I x 1	 M5 J x 1	 M4 K x 1	
 L x 6		II			

 M6x12mm A x 82	 M6x35mm C x 12	 M6x45mm D x 2	 M6 x 10mm F x 4
--	--	--	---

DE:Bitte beachten Sie, dass die Formen der Schrauben A und C und D und F ähnlich sind. Bitte installieren Sie entsprechend der Anleitung und unterscheiden Sie sie!

UK:Please note that the shapes of screws A and C and D and F are similar. Please install according to the instructions and distinguish them!

FR:Notez que les vis A et C et D et F ont des formes similaires. Veuillez les installer en suivant les instructions pour les séparer!

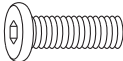
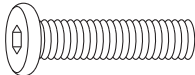
 M8 x 12mm B x 4	 M8x55mm E x 6	
---	---	--

DE:Bitte beachten Sie, dass die Formen der Schrauben B und E ähnlich sind. Bitte installieren Sie entsprechend der Anleitung und unterscheiden Sie sie!

UK:Please note that the shapes of screws B and E are similar. Please install according to the instructions and distinguish them!

FR:Notez que les vis B et E ont des formes similaires. Veuillez les installer en suivant les instructions pour les séparer!

Part list

SKU:N636P335094/N636P335095
N636P335096

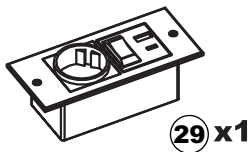
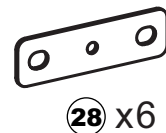
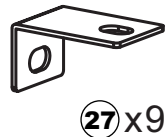
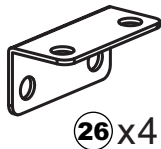
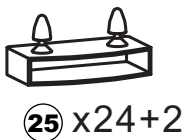
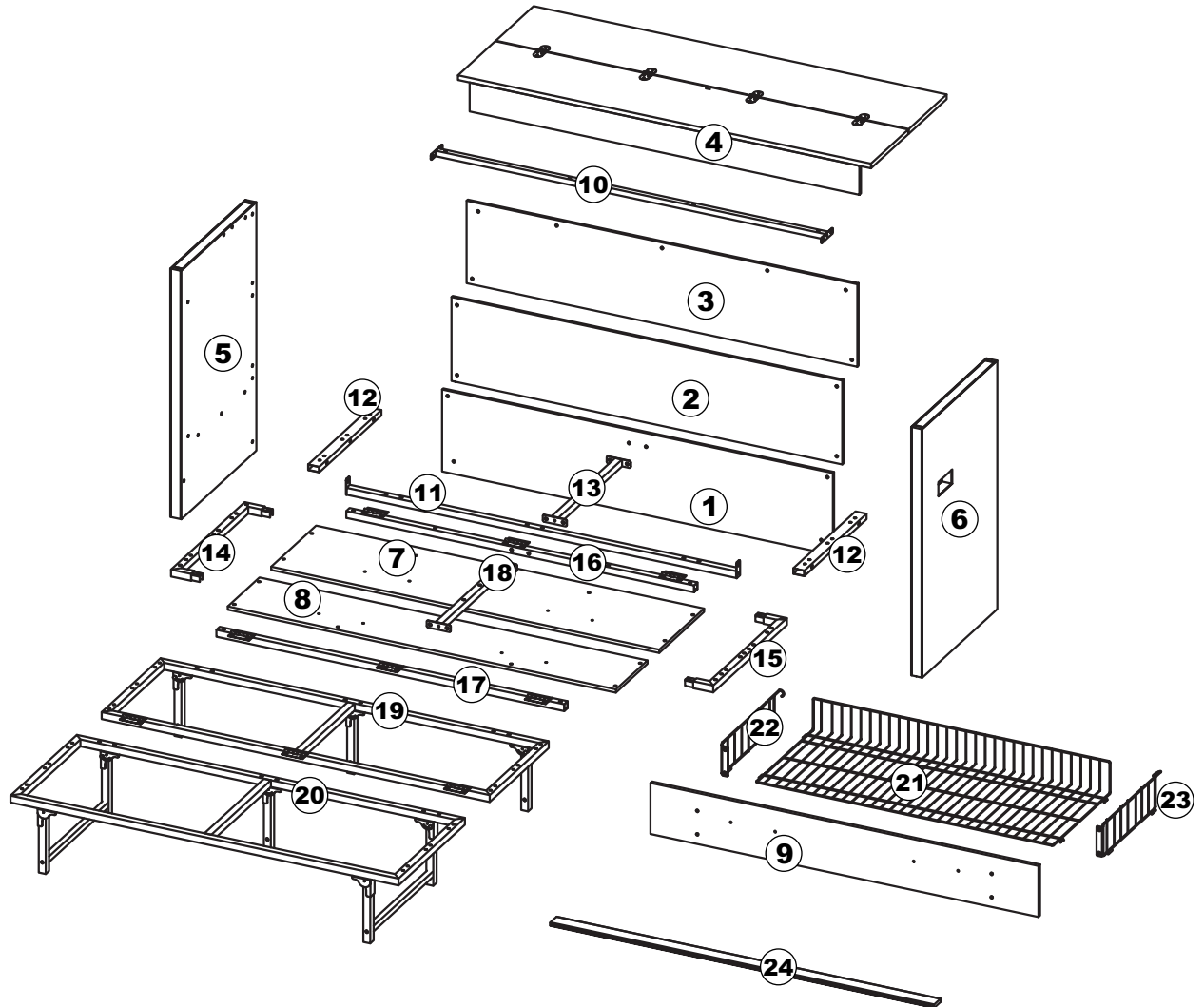

SKU:N636P335094/N636P335095 N636P335096

PART LIST (N636P335094) / STÜCKLISTE (N636P335094)

① x1

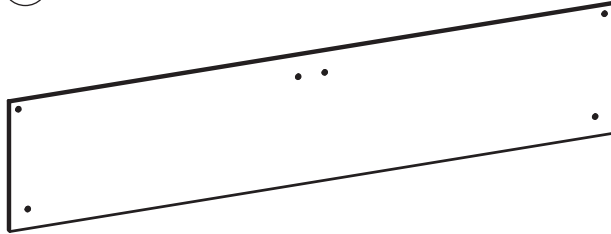

② x1

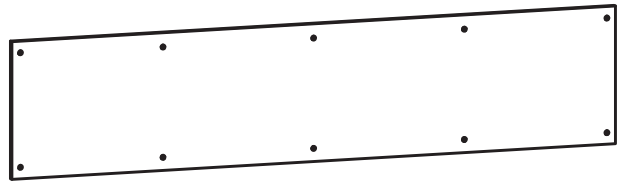

③ x1

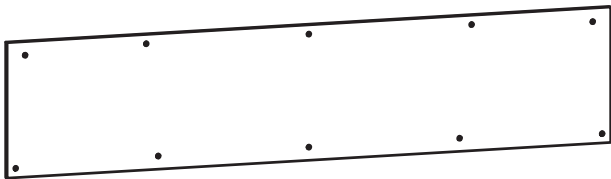

④ x1

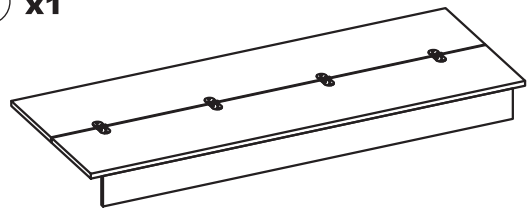

⑦ x1

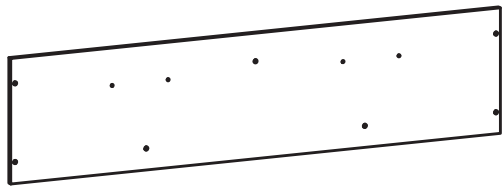

⑧ x1

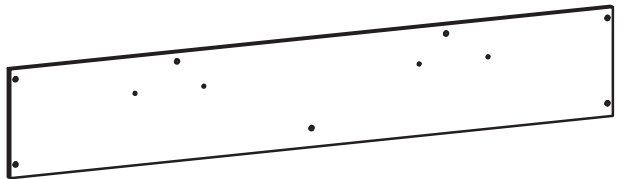

⑨ x1

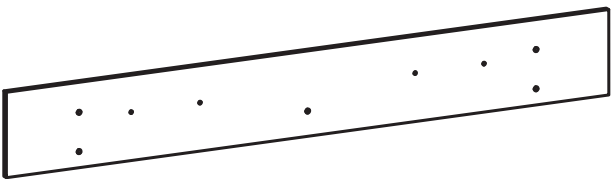

SKU:N636P335094/N636P335095 N636P335096

PART LIST (N636P335095) / STÜCKLISTE (N636P335095)

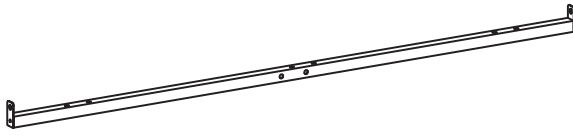
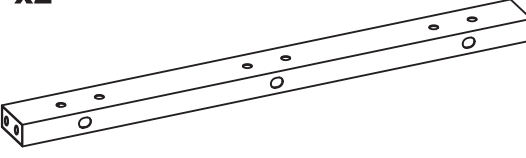
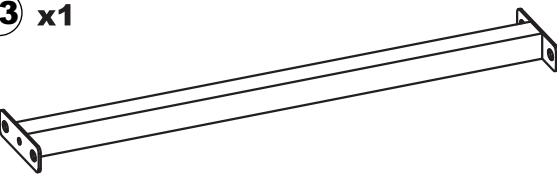
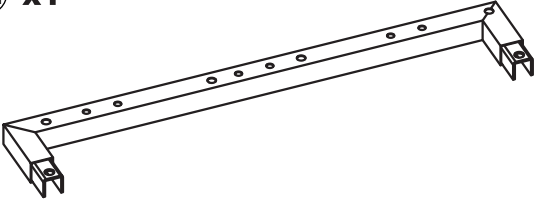
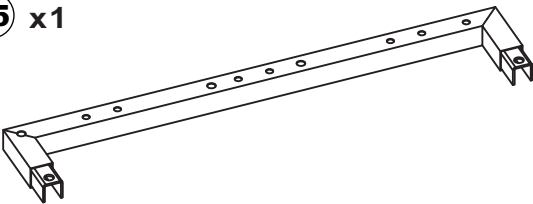
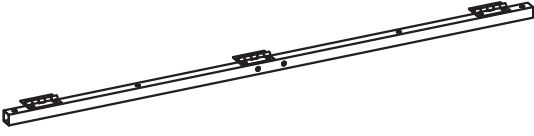
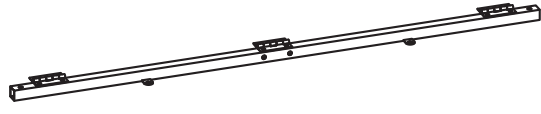
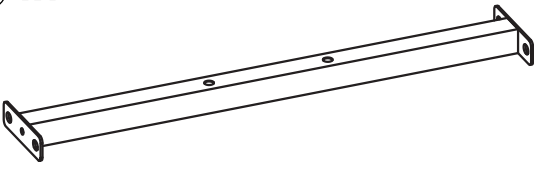
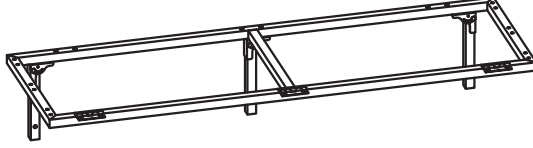
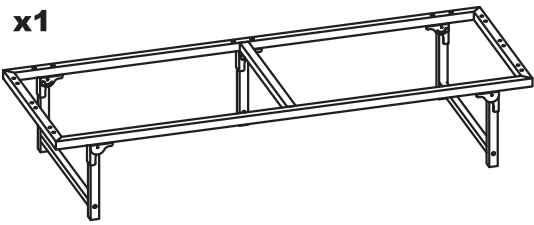
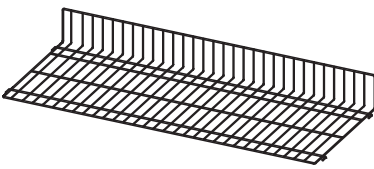
<p>10 x1</p> 	<p>11 x1</p> 
<p>12 x2</p> 	<p>13 x1</p> 
<p>14 x1</p> 	<p>15 x1</p> 
<p>16 x1</p> 	<p>17 x1</p> 
<p>18 x1</p> 	<p>19 x1</p> 
<p>20 x1</p> 	<p>21 x1</p> 

22 x1

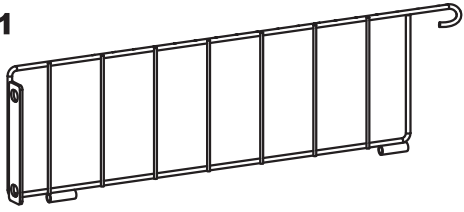

23 x1

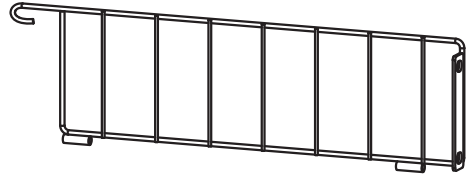

24 x12

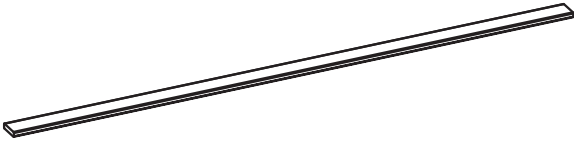

25 x24+2

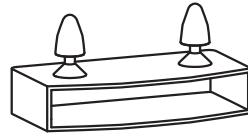

26 x4

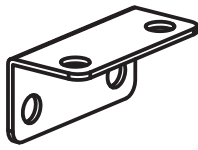

27 x9

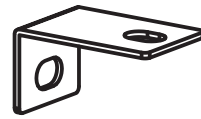

28 x6

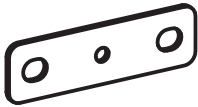

29 x1

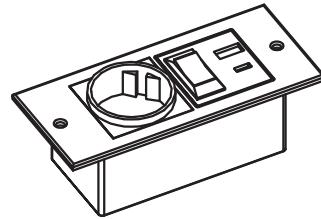

SKU:N636P335094/N636P335095 N636P335096

PART LIST (N636P335096) / STÜCKLISTE (N636P335096)

⑤ x1

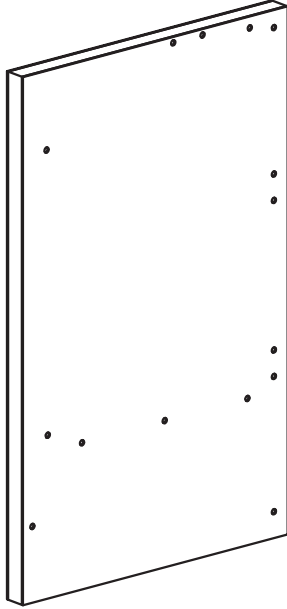



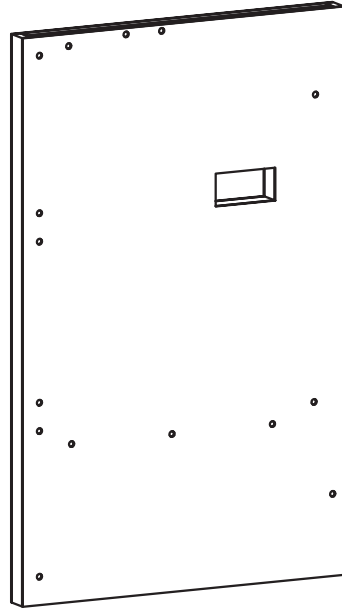

⑥ x1

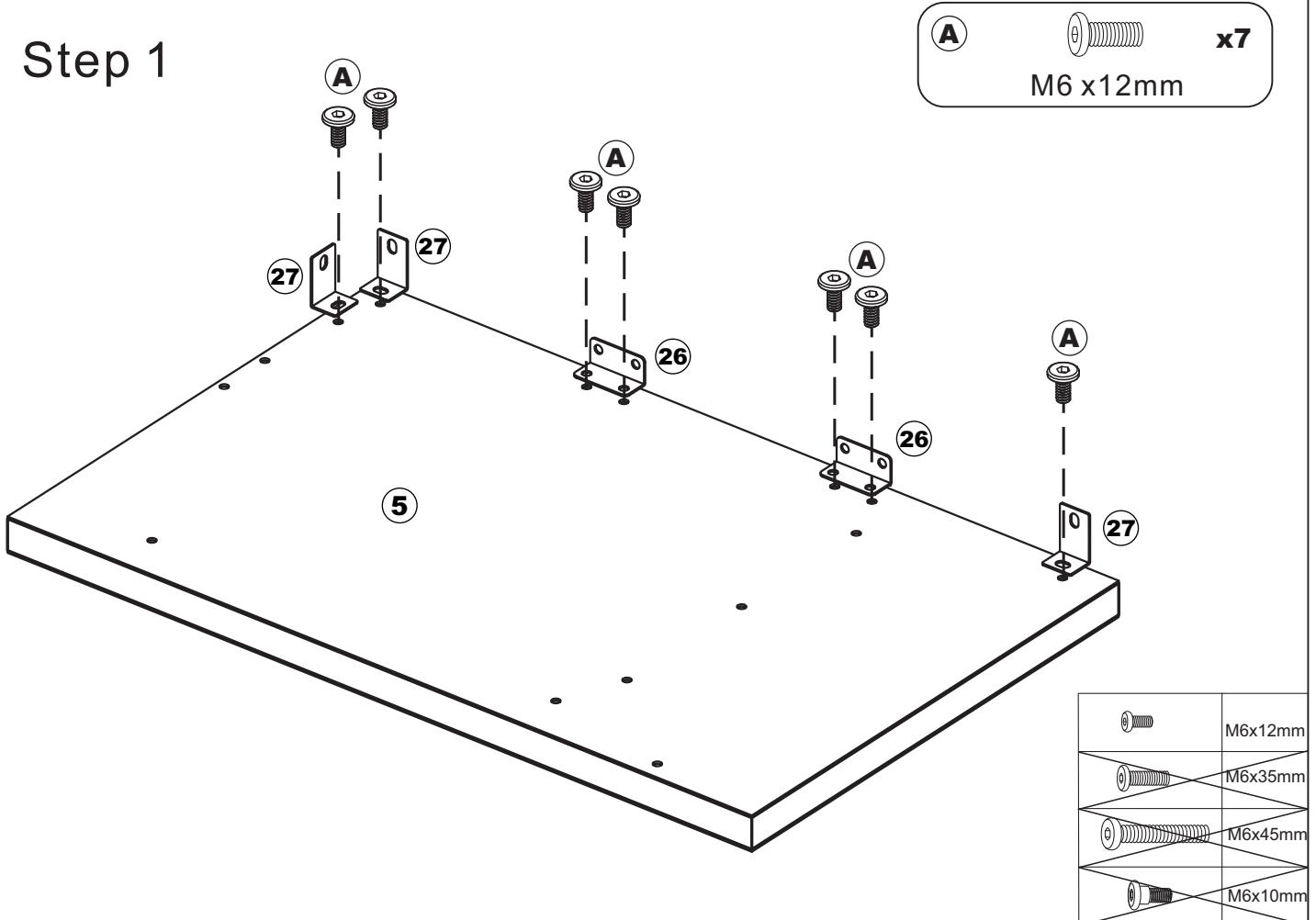

Step 1





A  **x7**
M6 x 12mm



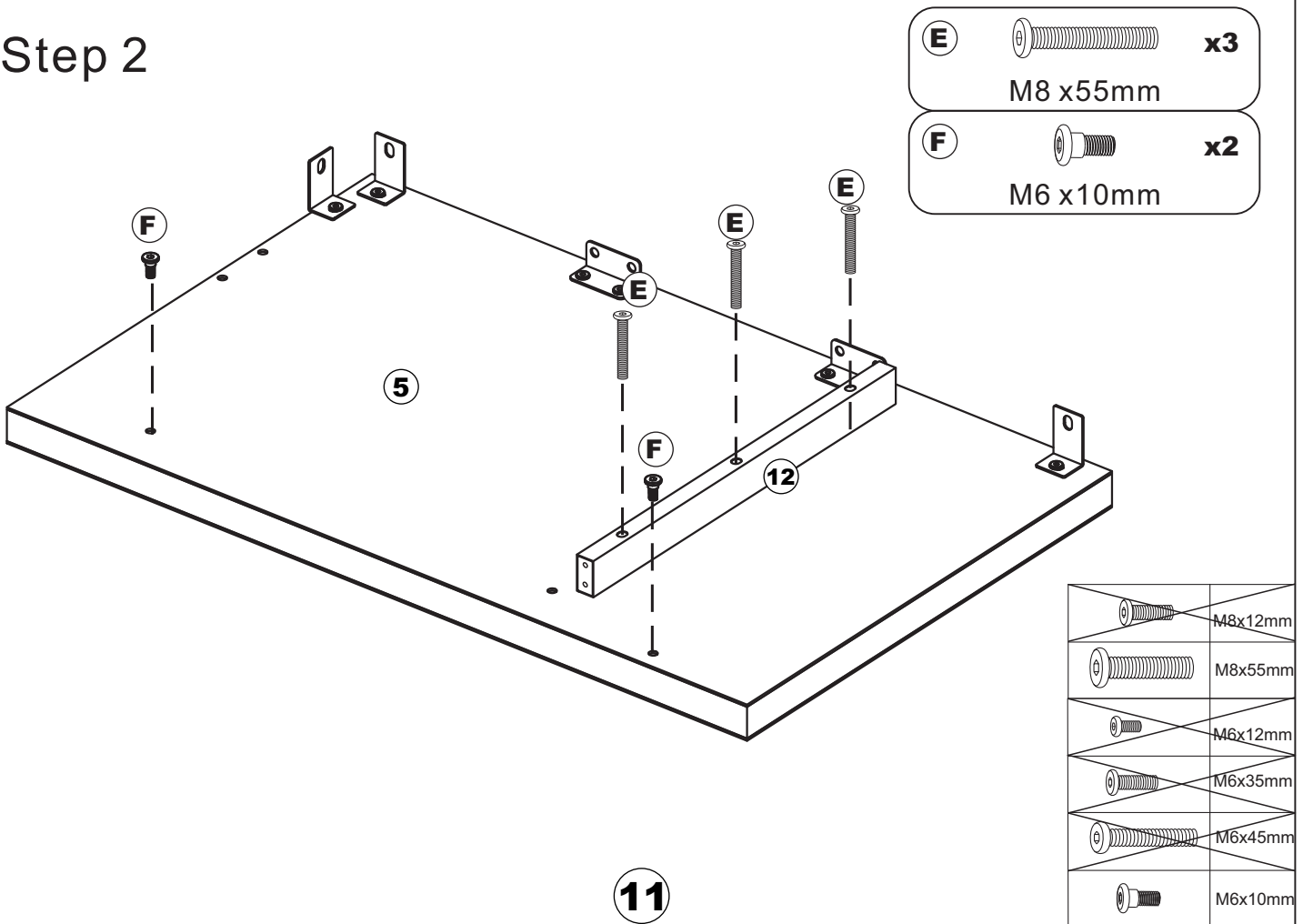



	M6x12mm
	M6x35mm
	M6x45mm
	M6x10mm

Step 2



E  **x3**
M8 x 55mm





F  **x2**
M6 x 10mm

	M8x12mm
	M8x55mm
	M6x12mm
	M6x35mm
	M6x45mm
	M6x10mm

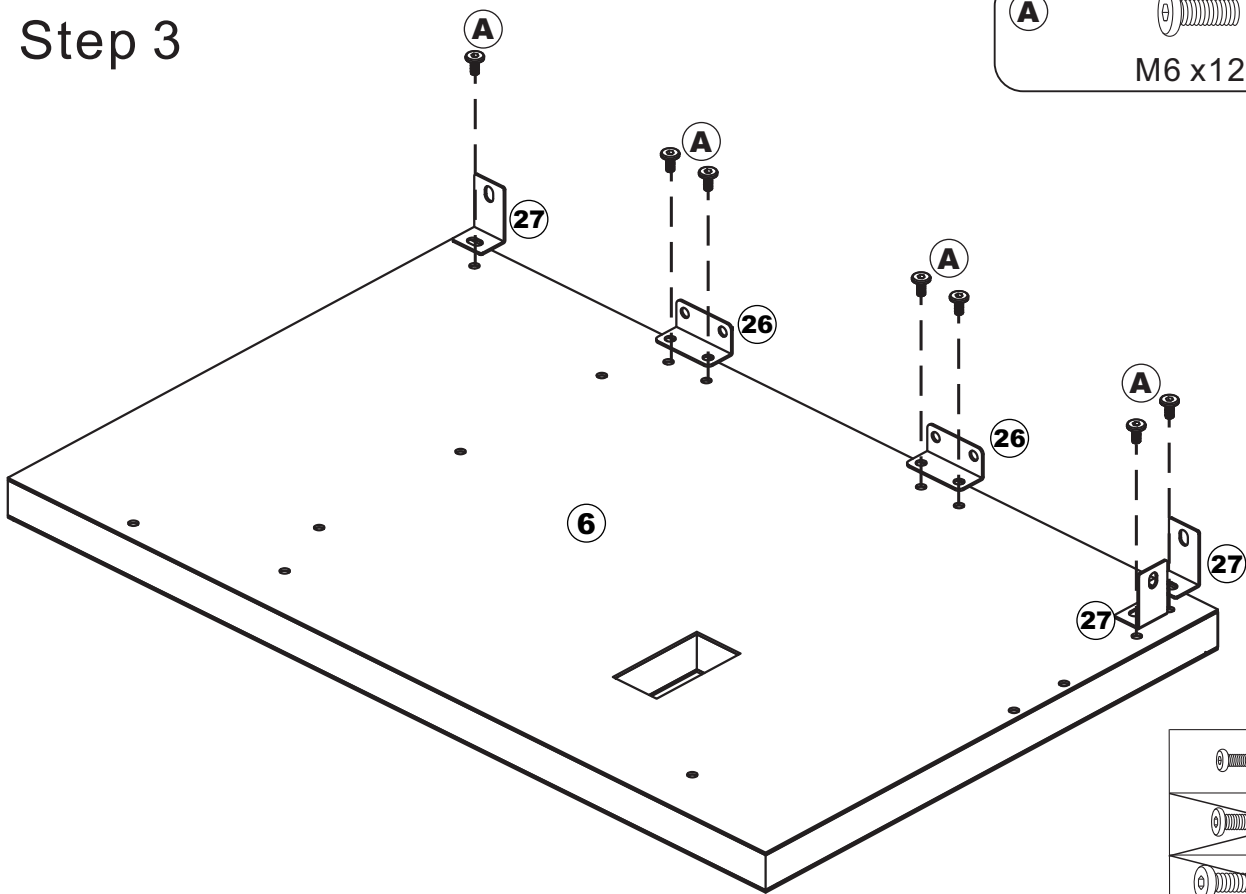
Step 3

A  **x7**
M6 x12







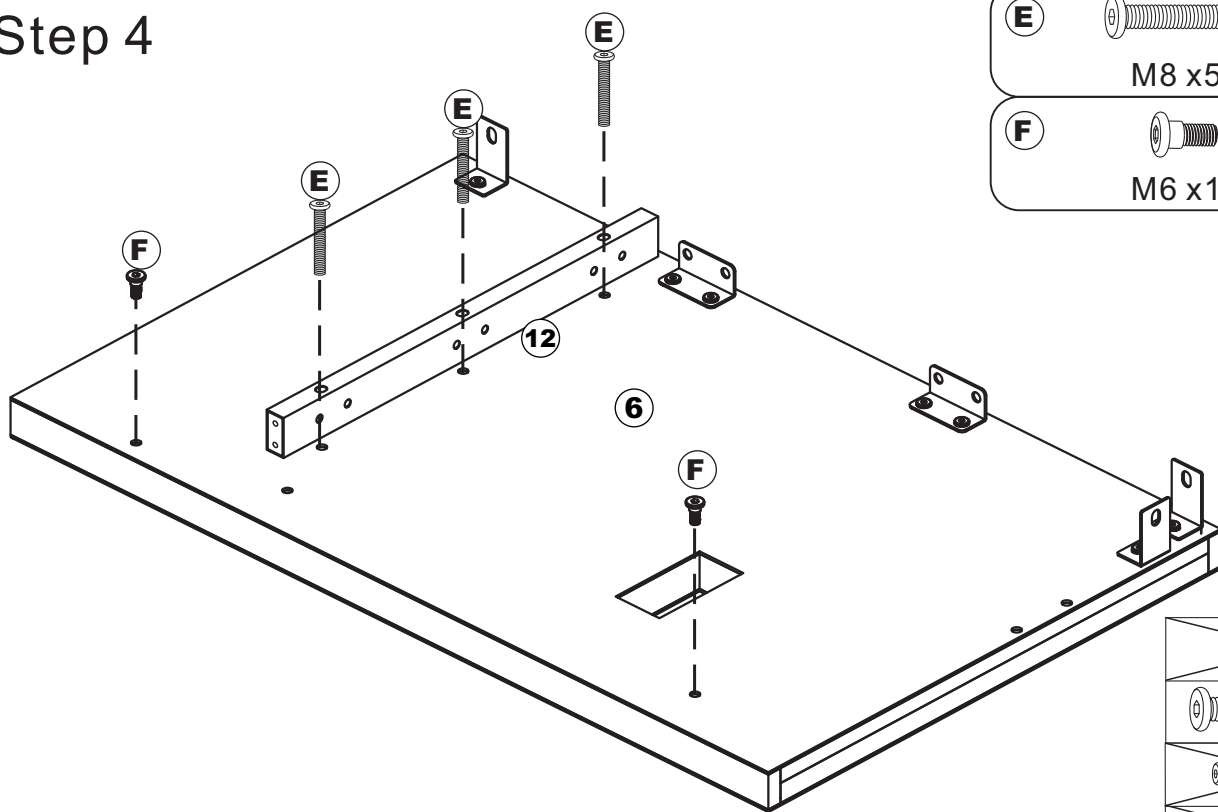

	M6x12mm
	M6x35mm
	M6x45mm
	M6x10mm

Step 4

E  **x3**
M8 x55

F  **x2**
M6 x10



	M8x12mm
	M8x55mm
	M6x12mm
	M6x35mm
	M6x45mm
	M6x10mm

Step 5



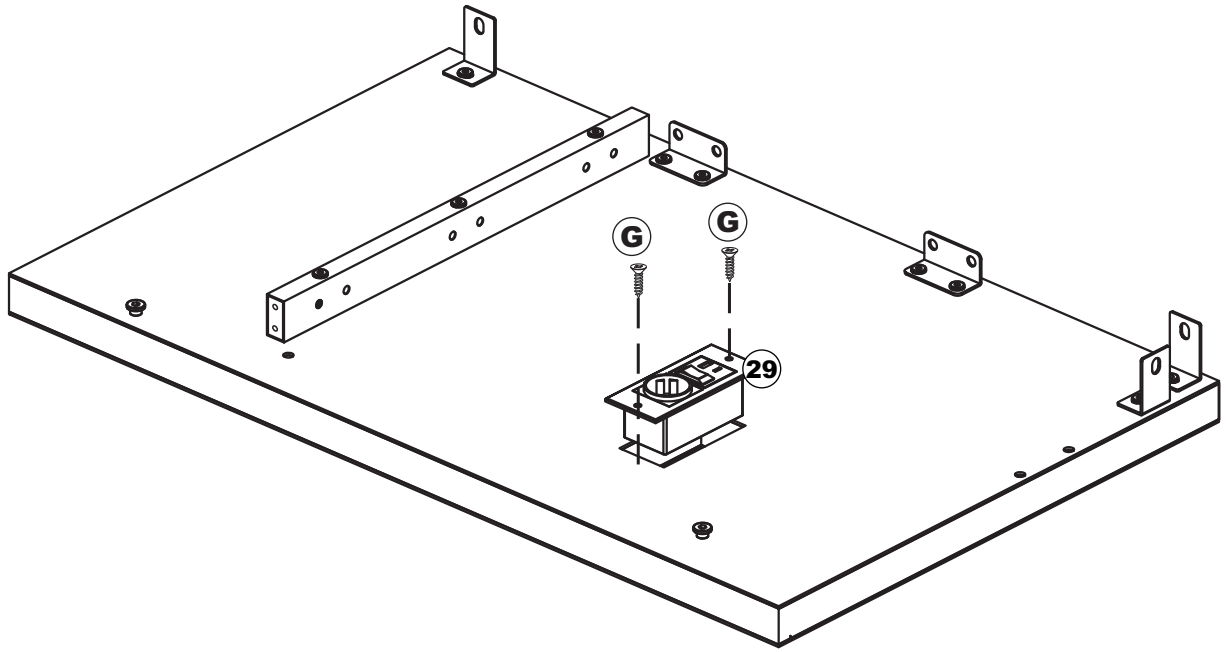

G  **x2**
Ø4 x 12mm

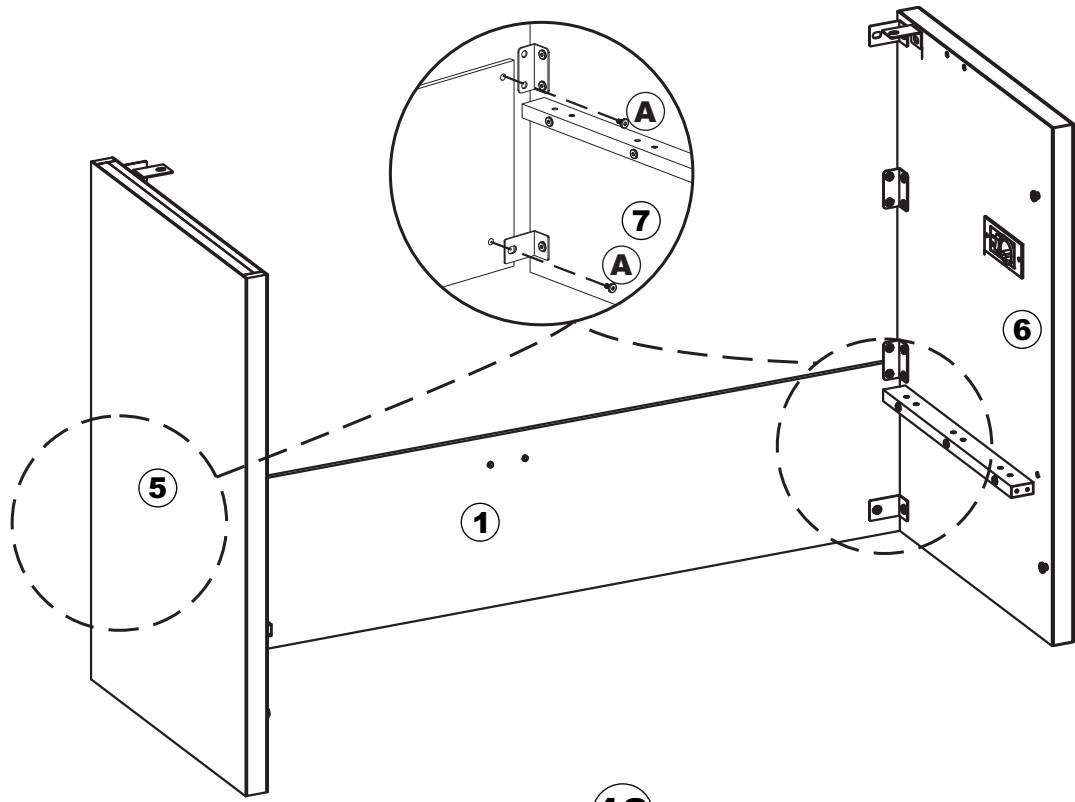

Step 6

A  **x4**
M6 x 12





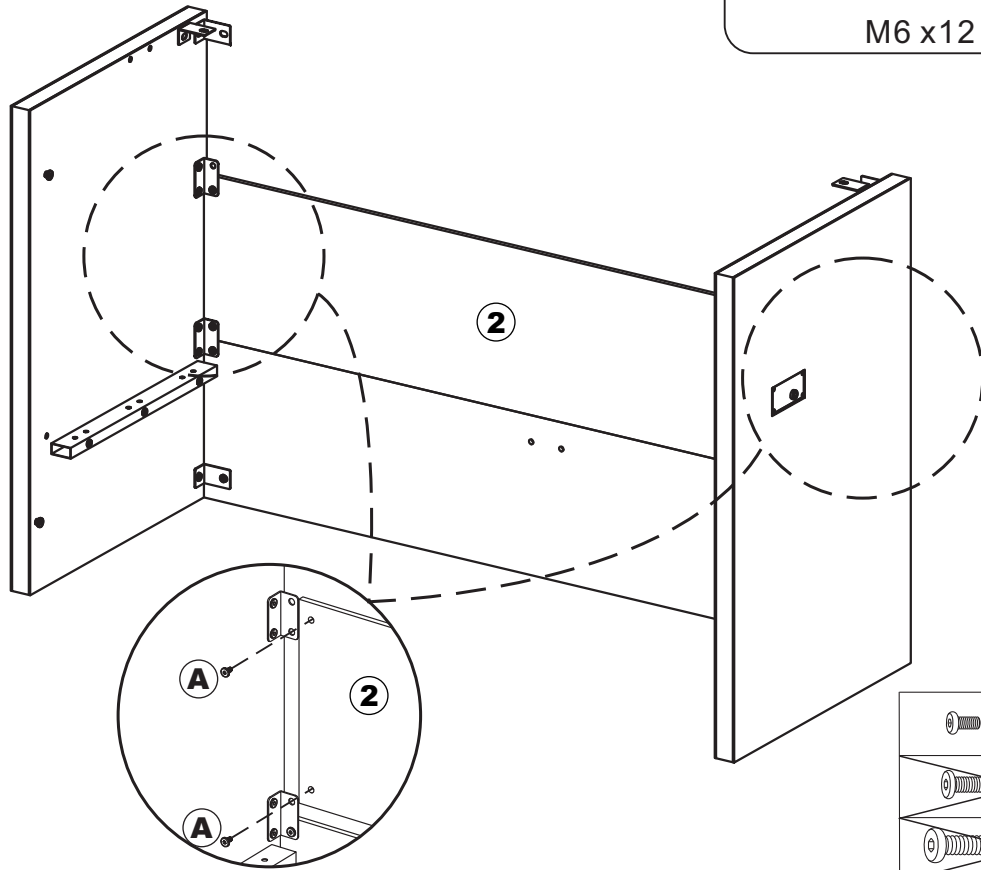

	M6x12mm
	M6x35mm
	M6x45mm
	M6x10mm

13

Step 7





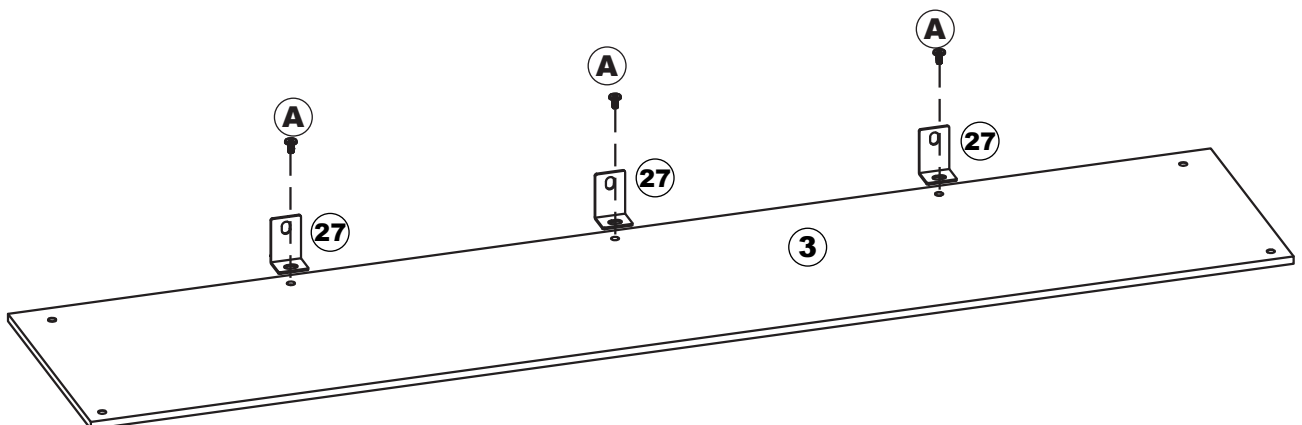

A  **x4**
M6 x12

	M6x12mm
	M6x35mm
	M6x45mm
	M6x10mm

Step 8





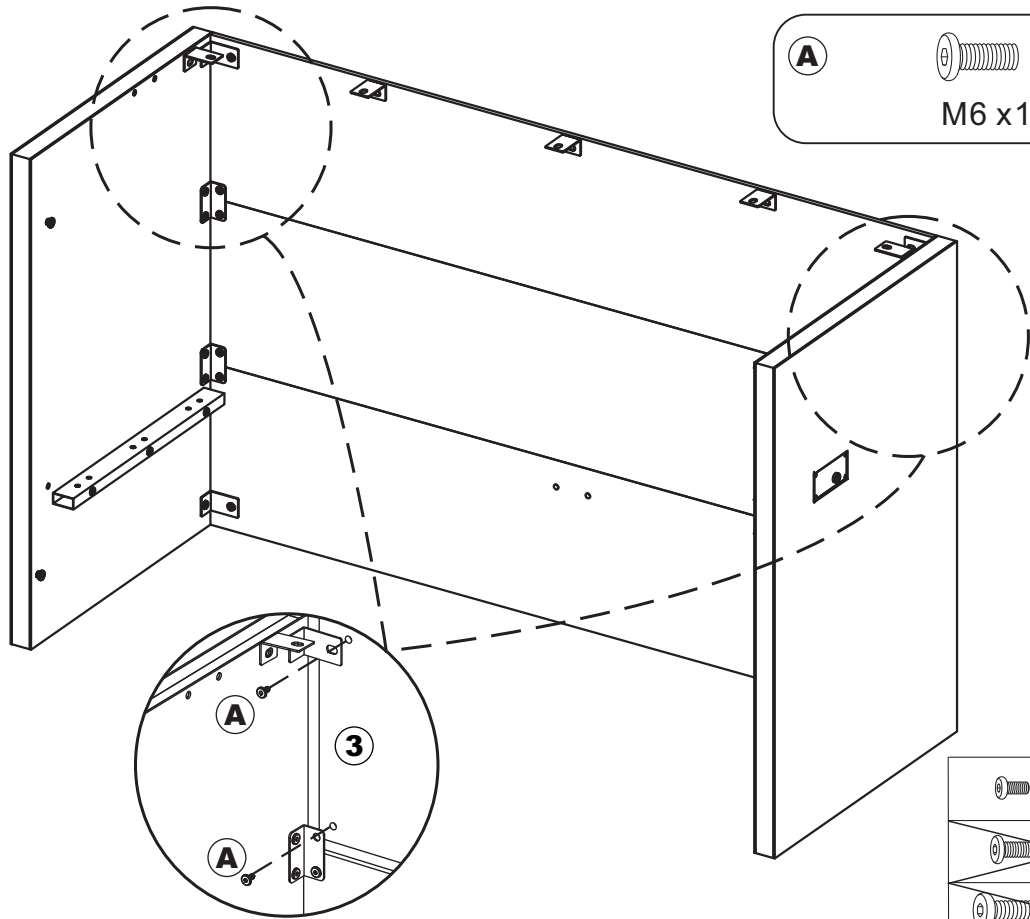

A  **x3**
M6 x12

	M6x12mm
	M6x35mm
	M6x45mm
	M6x10mm

Step 9





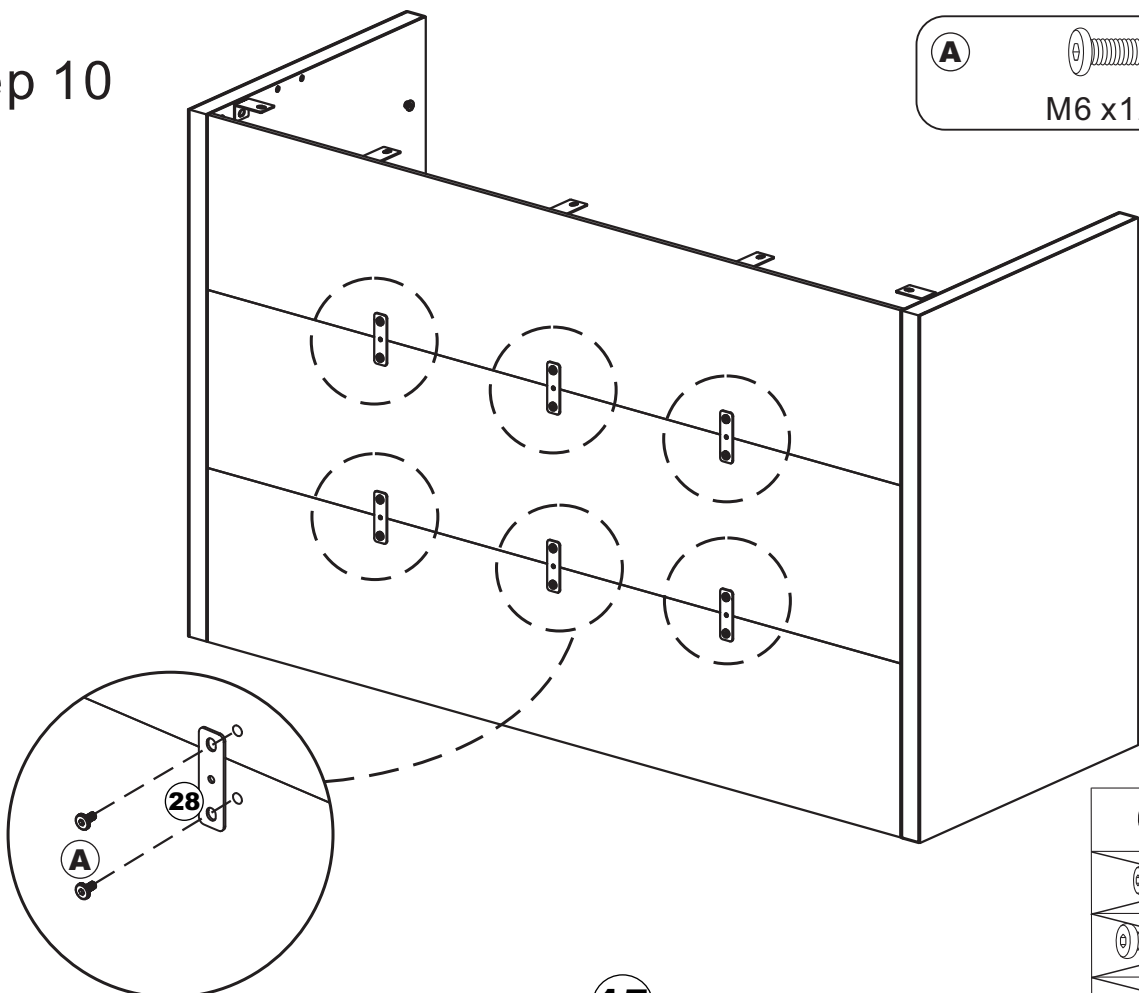

A  **x4**
M6 x12

	M6x12mm
	M6x35mm
	M6x45mm
	M6x10mm

Step 10





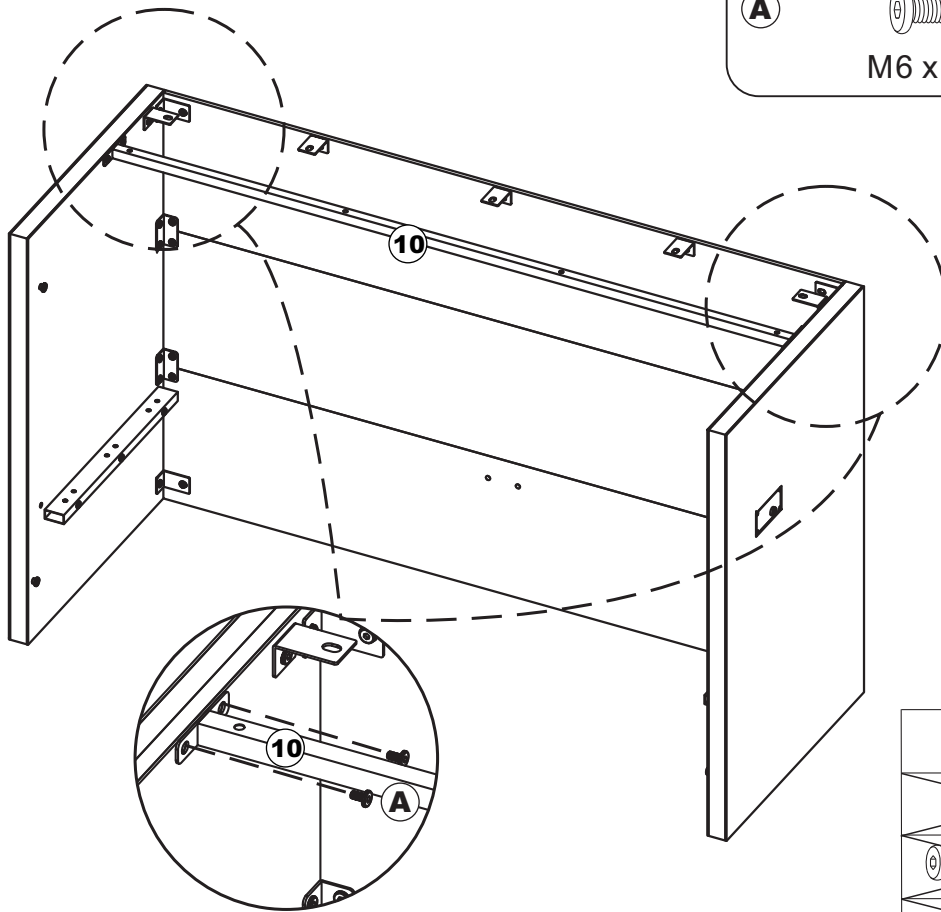

A  **x12**
M6 x12

	M6x12mm
	M6x35mm
	M6x45mm
	M6x10mm

Step 11





A  **x4**
M6 x12



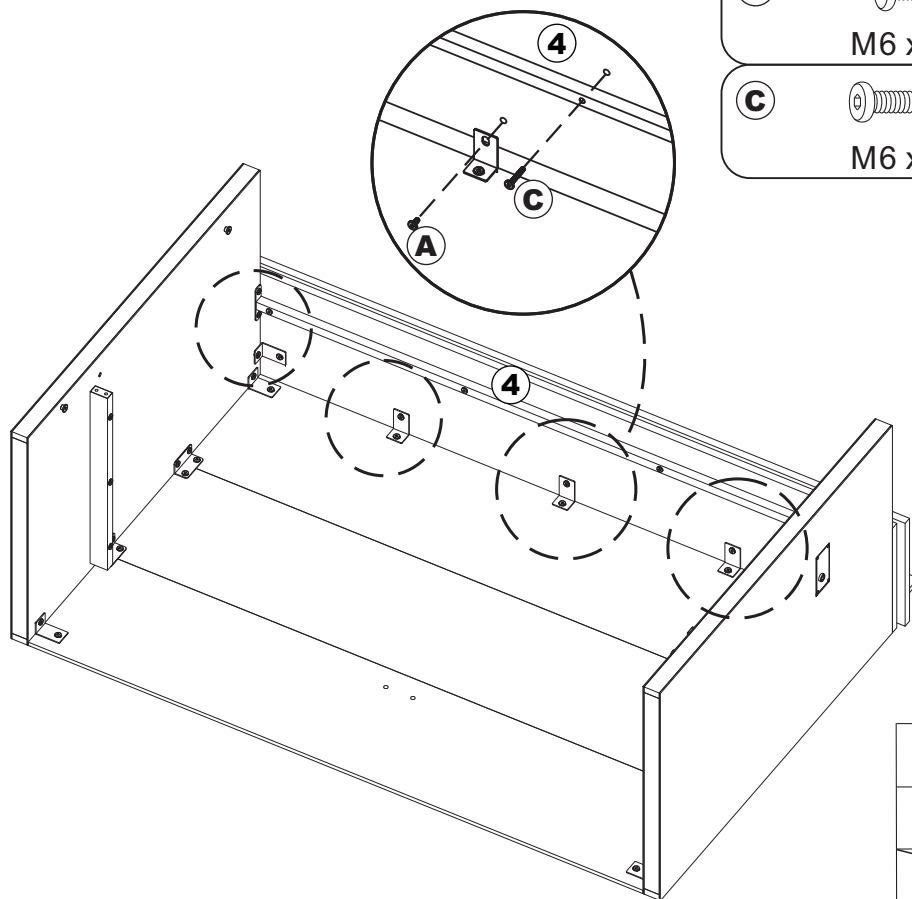

	M6x12mm
	M6x35mm
	M6x45mm
	M6x10mm

Step 12





A  **x5**
M6 x12



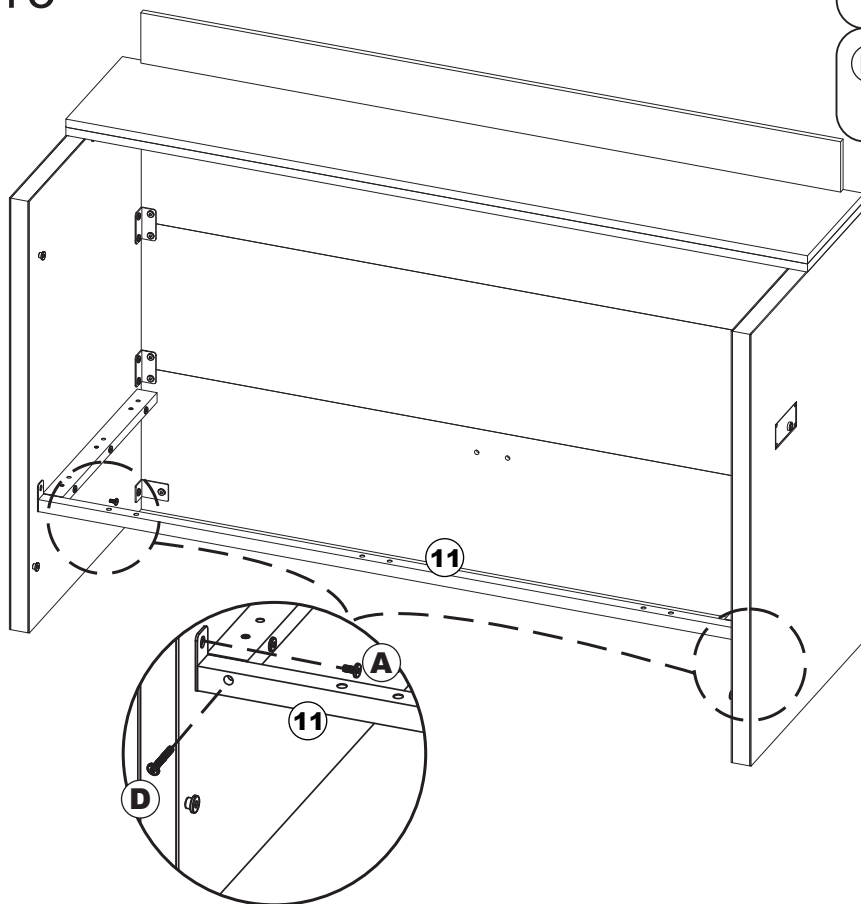

C  **x4**
M6 x35

	M6x12mm
	M6x35mm
	M6x45mm
	M6x10mm

Step 13





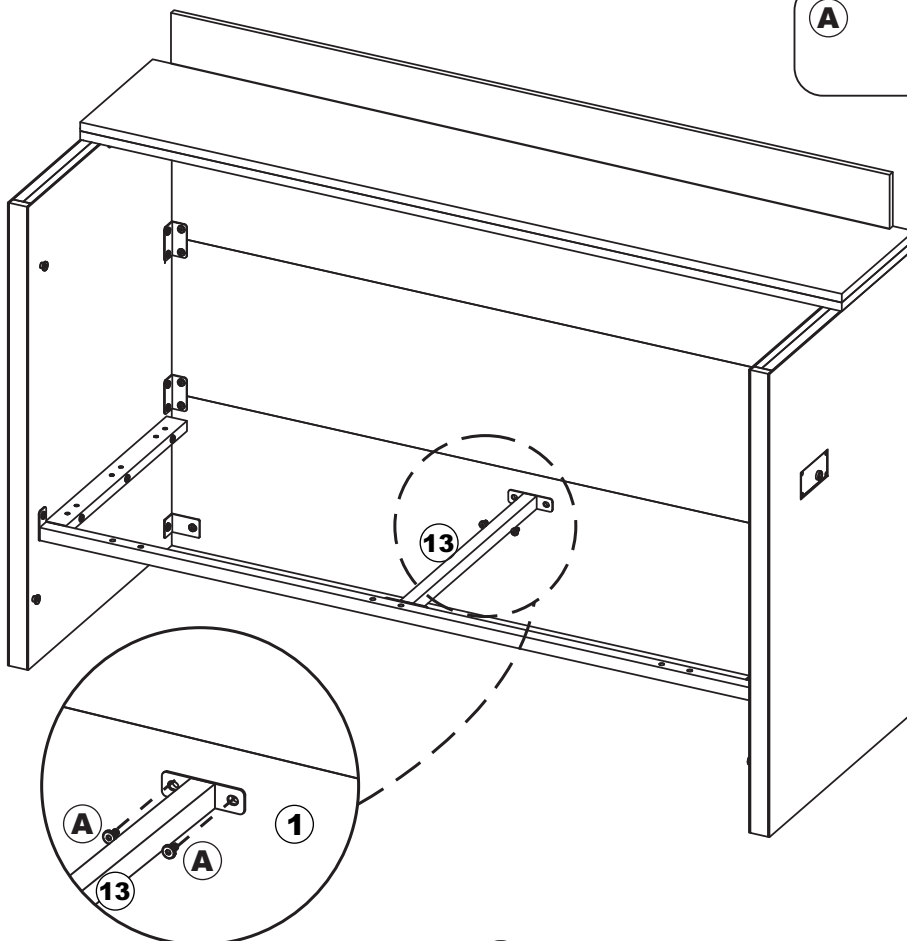

- A**  **x2**
M6 x12
- D**  **x2**
M6 x45

	M6x12mm
	M6x35mm
	M6x45mm
	M6x10mm

Step 14



- A**  **x4**
M6 x12

	M6x12mm
	M6x35mm
	M6x45mm
	M6x10mm

Step 15

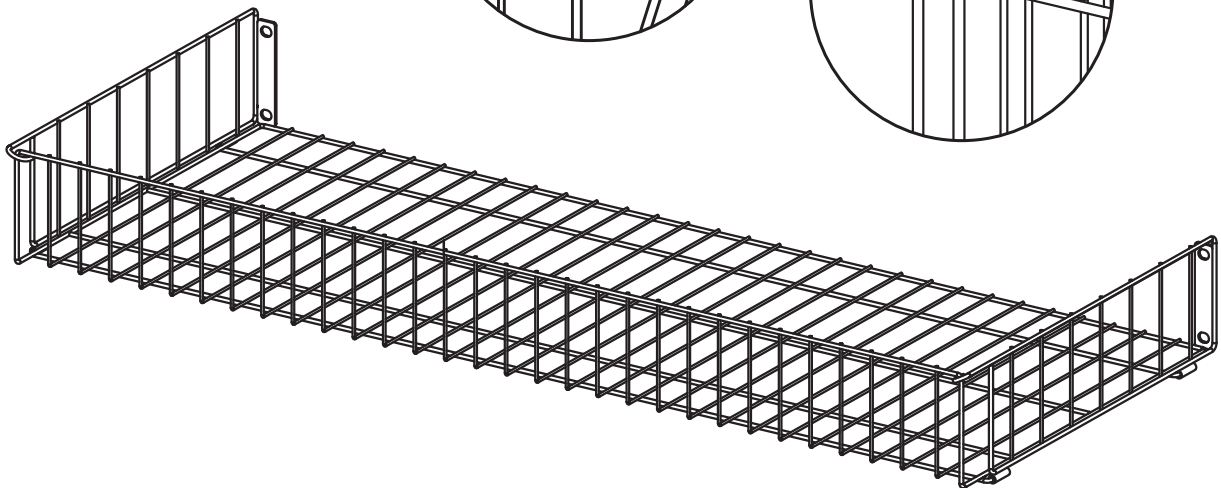
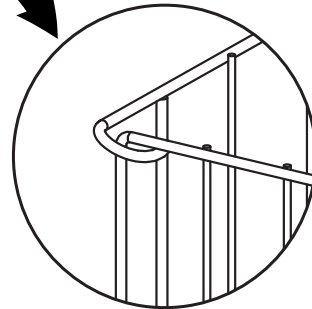
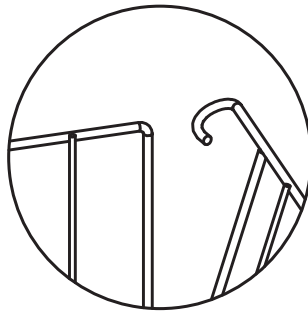
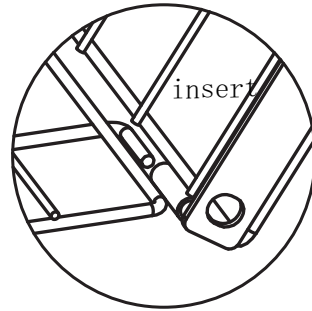
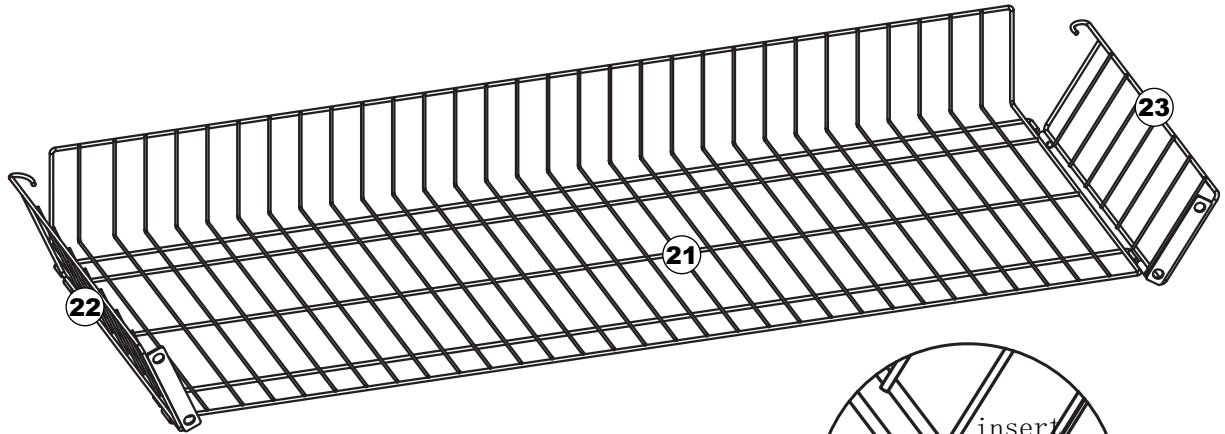

Step 16

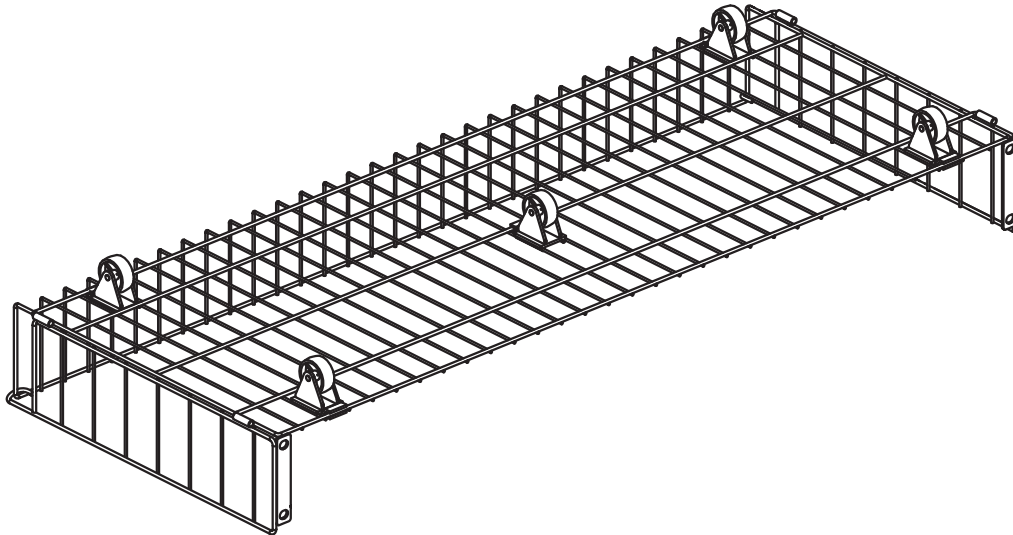
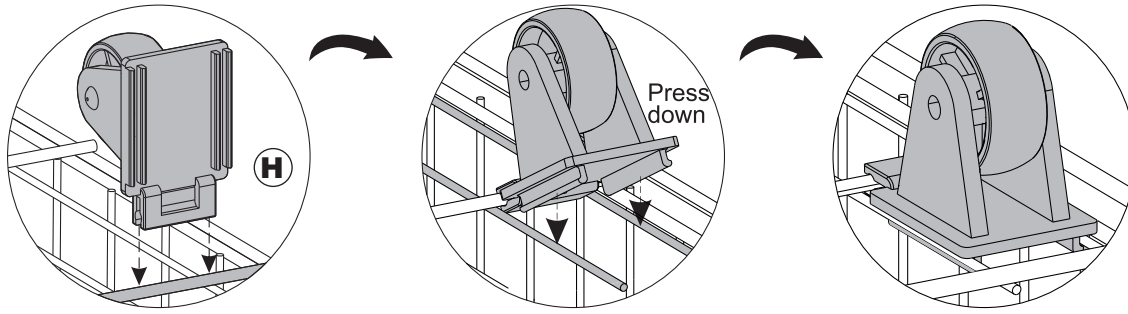
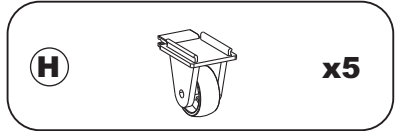



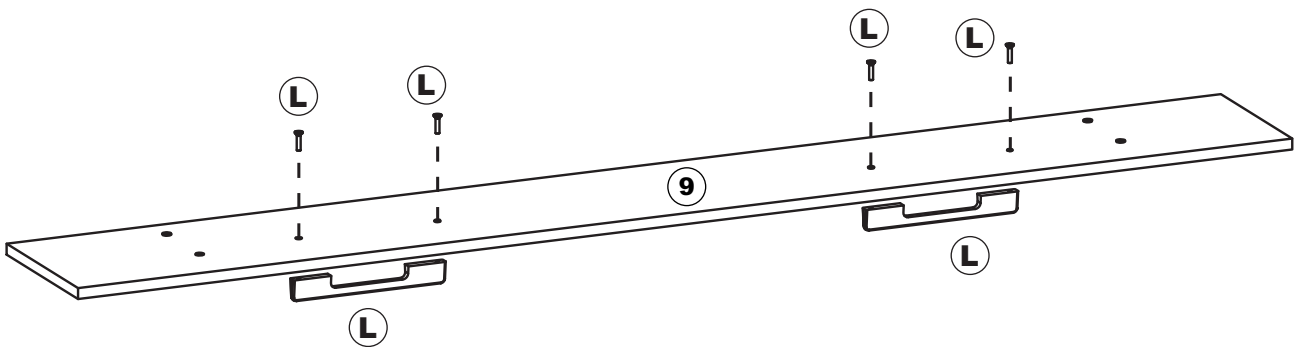
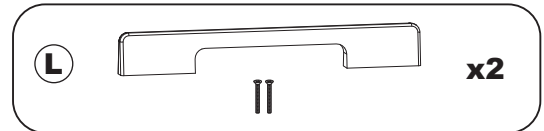

Step 17

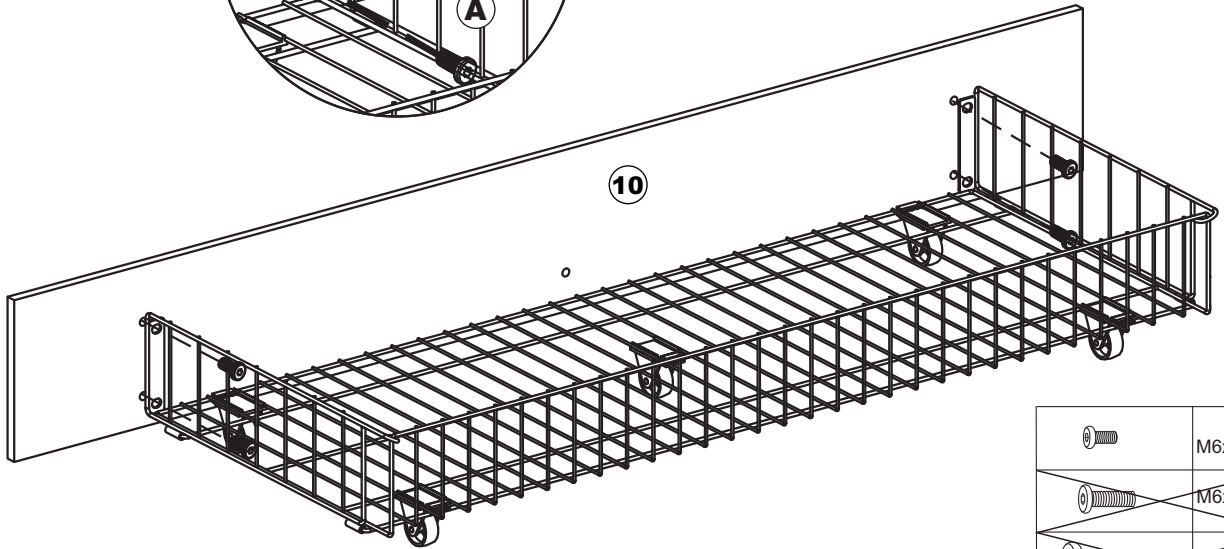
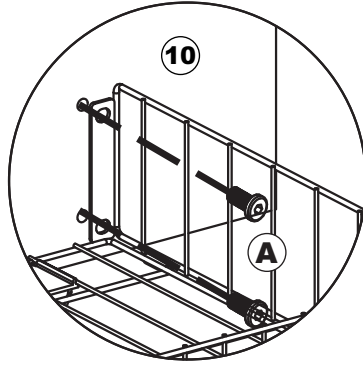

Step 18

A  **x4**
M6 x12







	M6x12mm
	M6x35mm
	M6x45mm
	M6x10mm

Step 19

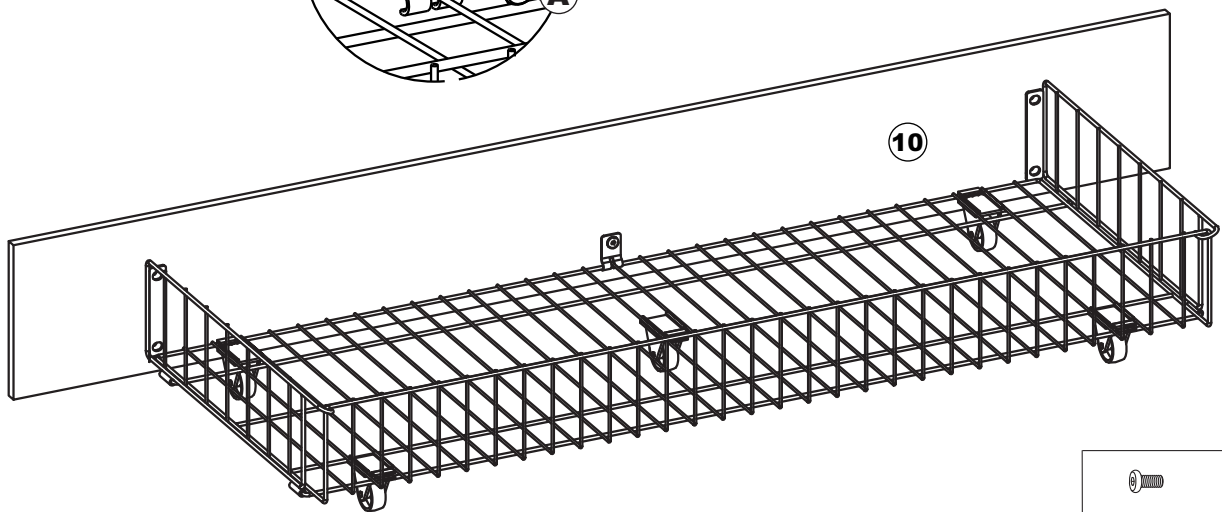
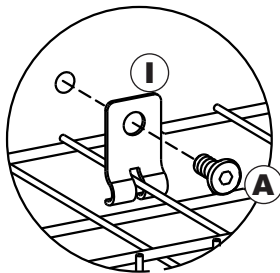
A  **x1**
M6 x12

I  **x1**



	M6x12mm
	M6x35mm
	M6x45mm
	M6x10mm

Step 20

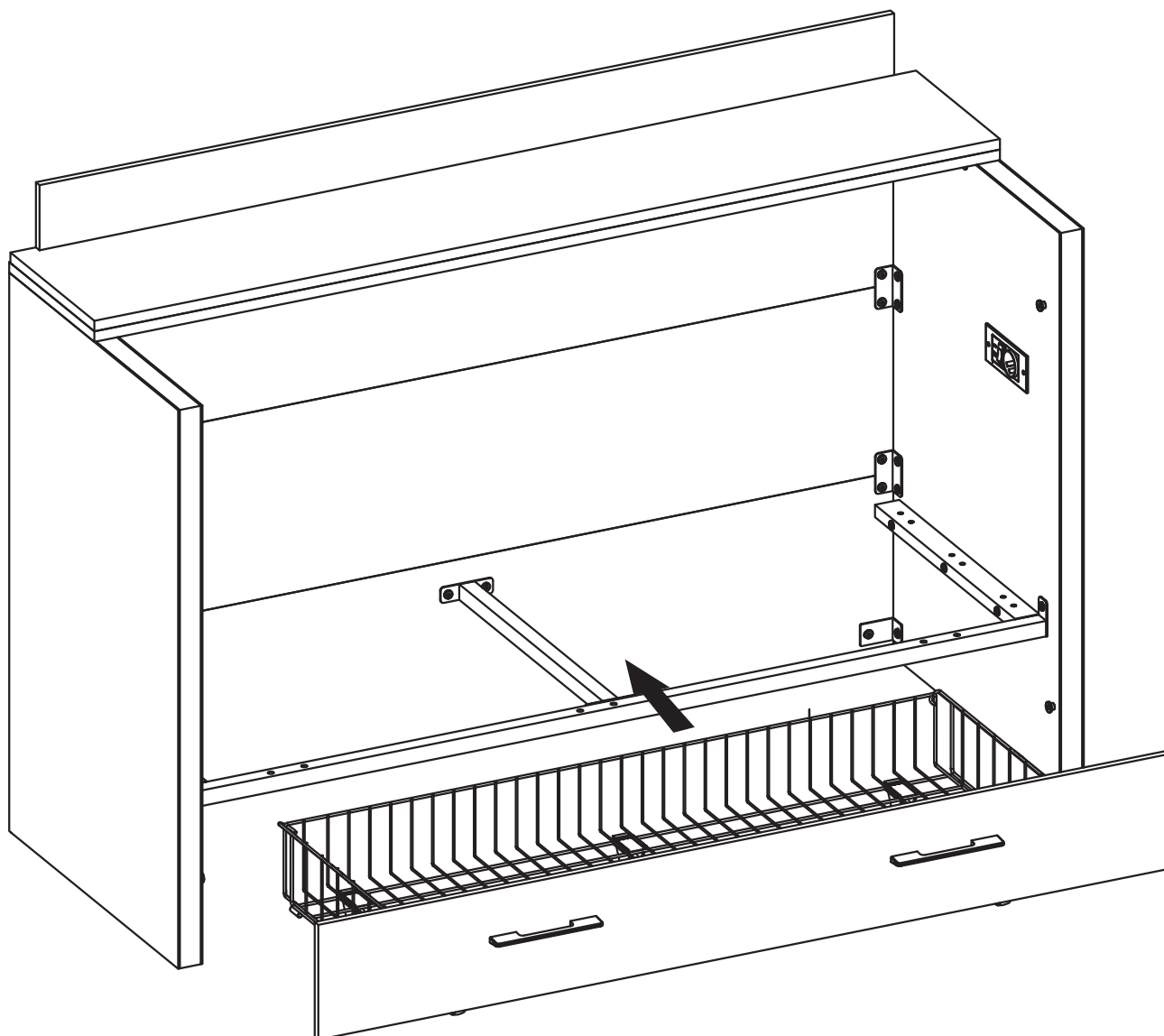

Step 21

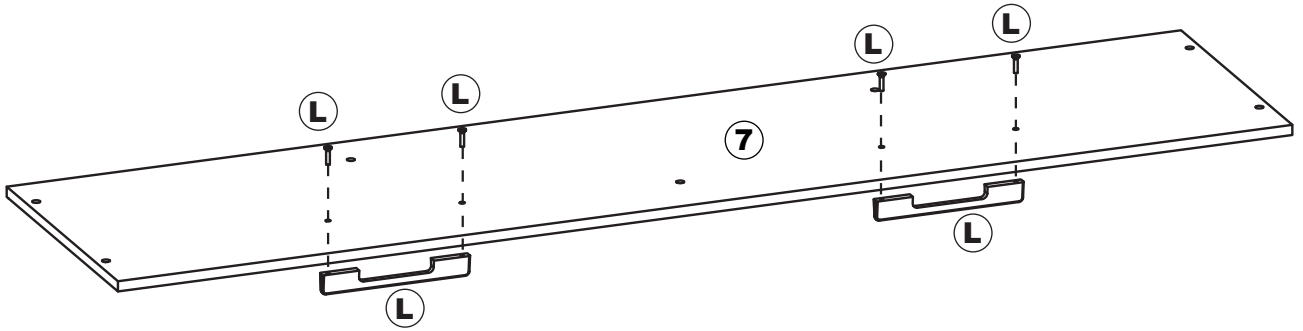
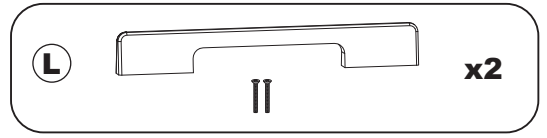

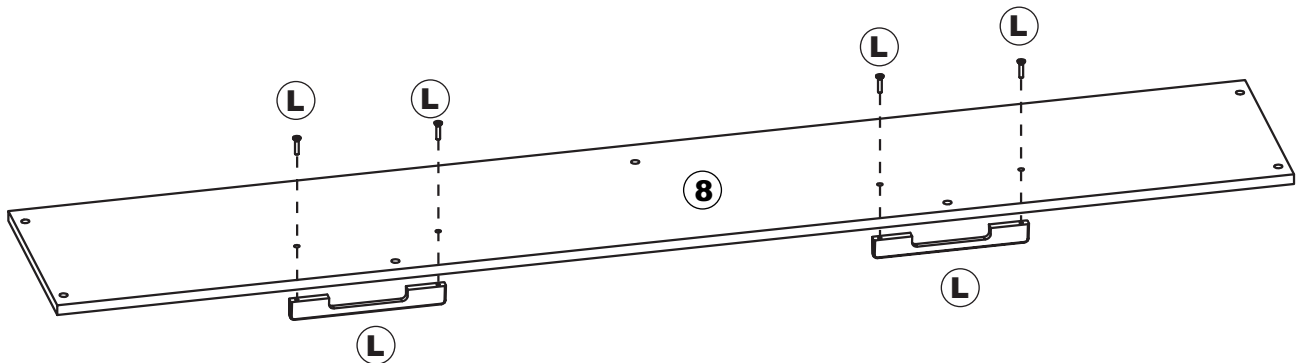
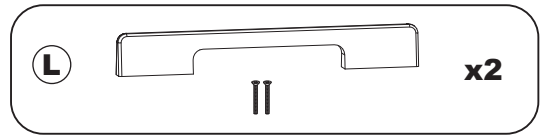

Step 22

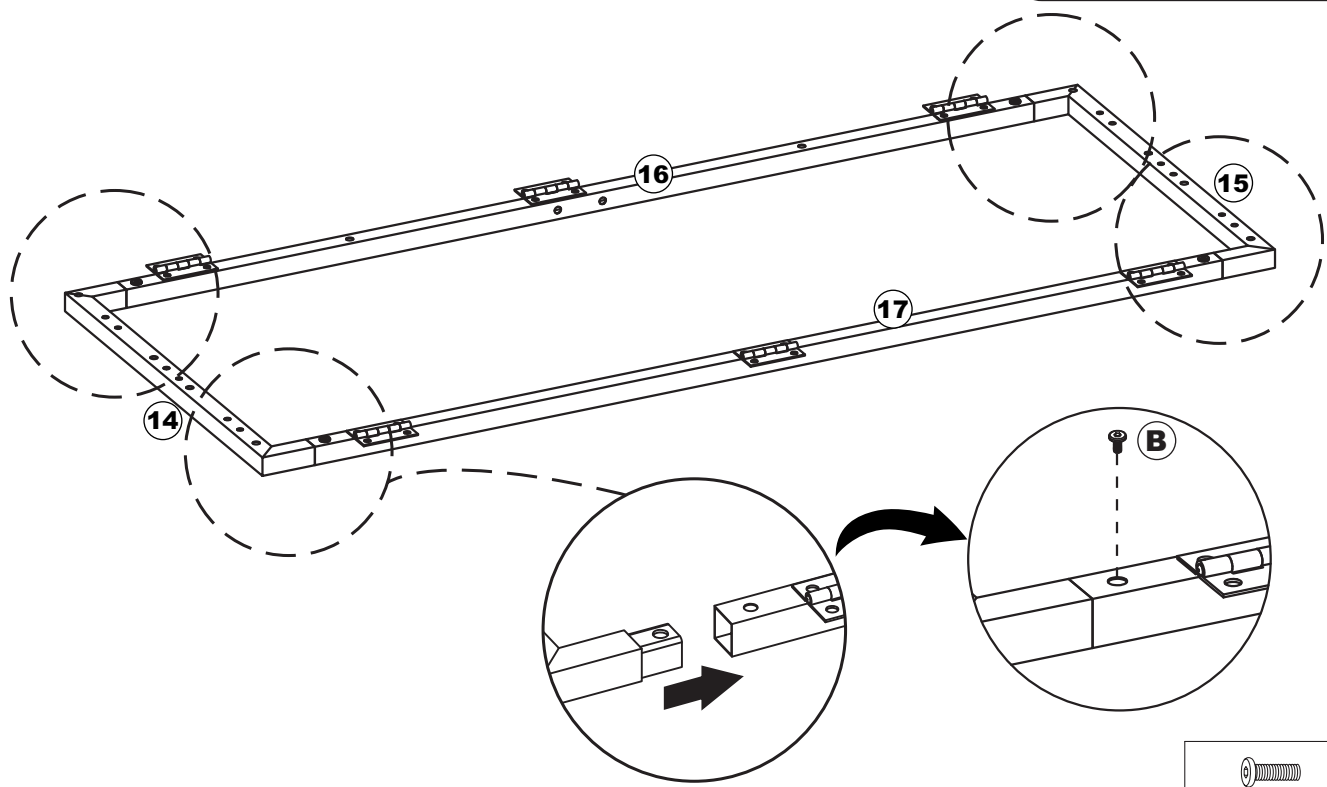

Step 23

B  **x4**
M8 x12







	M8x12mm
	M8x55mm

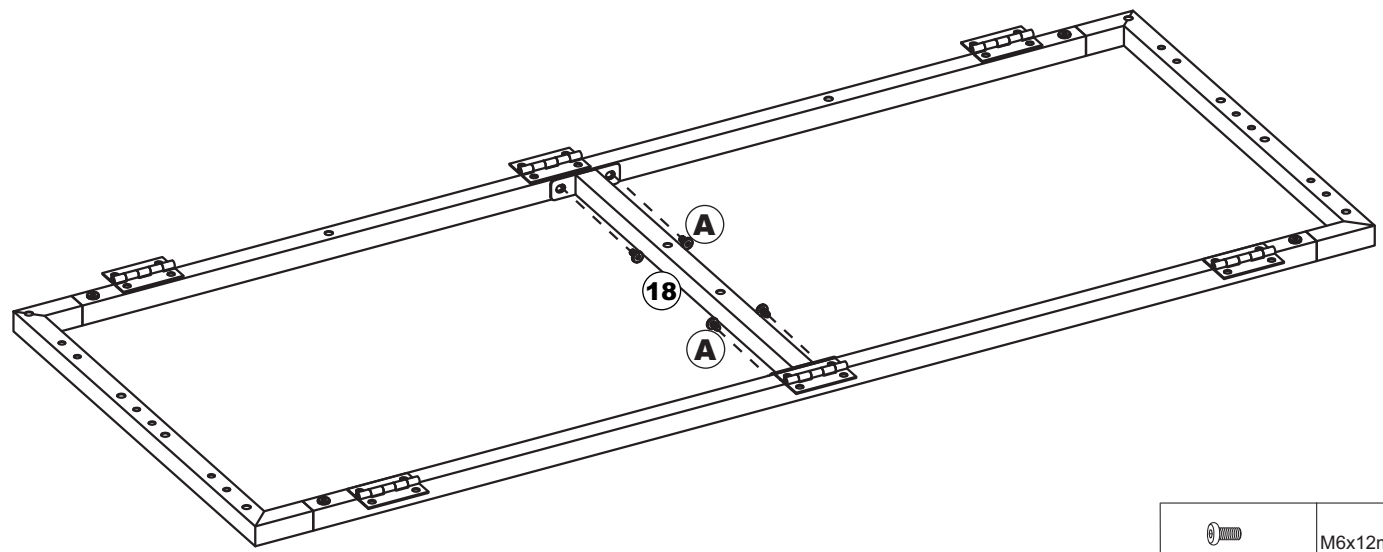

Step 24

A  **x4**
M6 x12





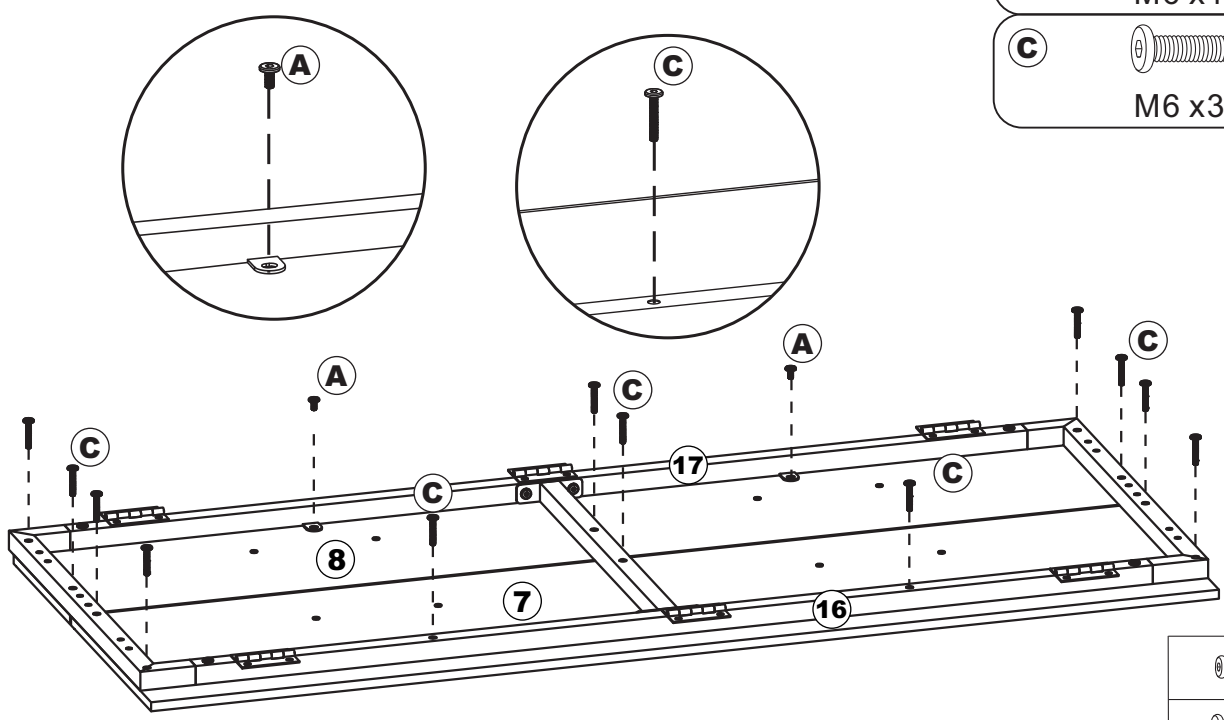

	M6x12mm
	M6x35mm
	M6x45mm
	M6x10mm

Step 25

- A**  **x2**
M6 x12
- C**  **x12**
M6 x35





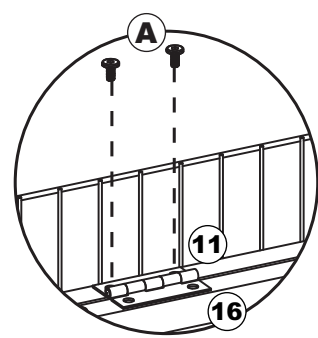
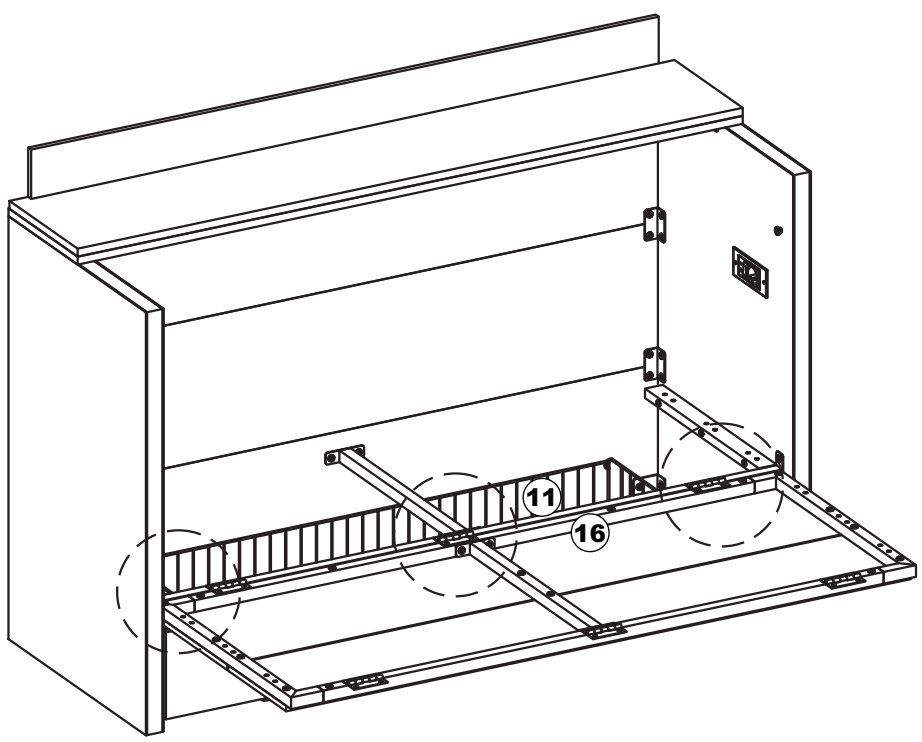

	M6x12mm
	M6x35mm
	M6x45mm
	M6x10mm

Step 26

- A**  **x6**
M6 x12





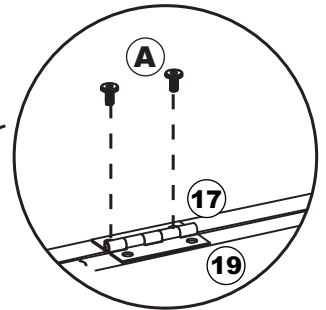
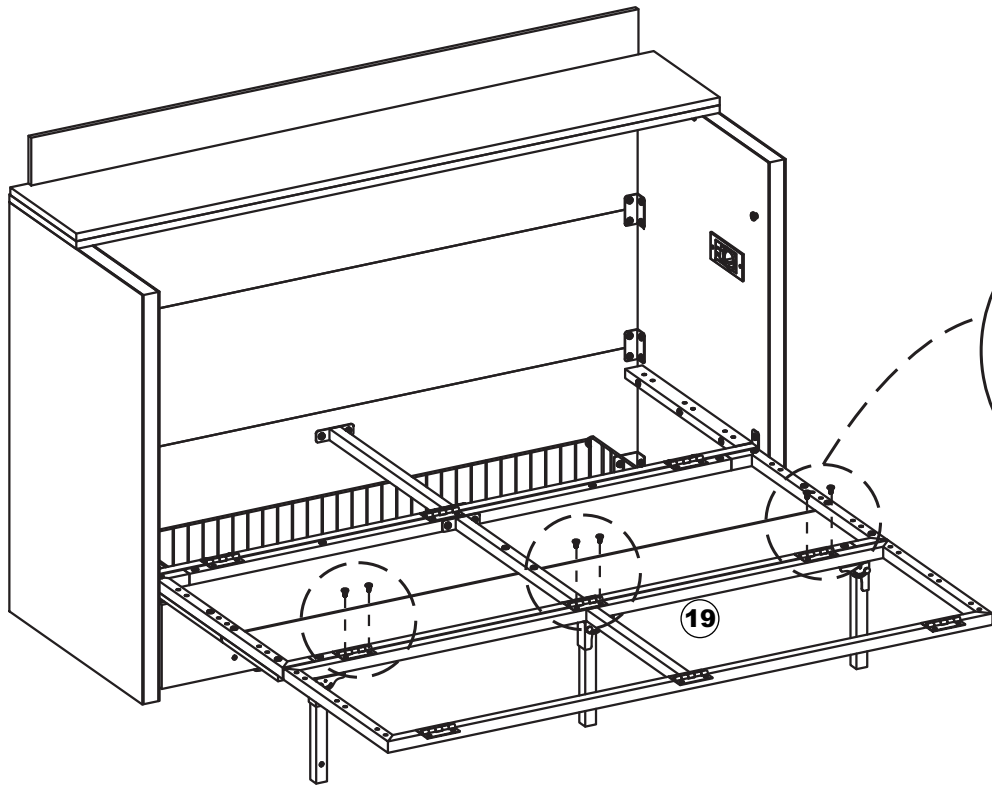

	M6x12mm
	M6x35mm
	M6x45mm
	M6x10mm

Step 27

A  **x6**
M6 x12





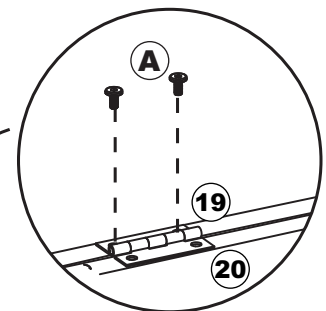
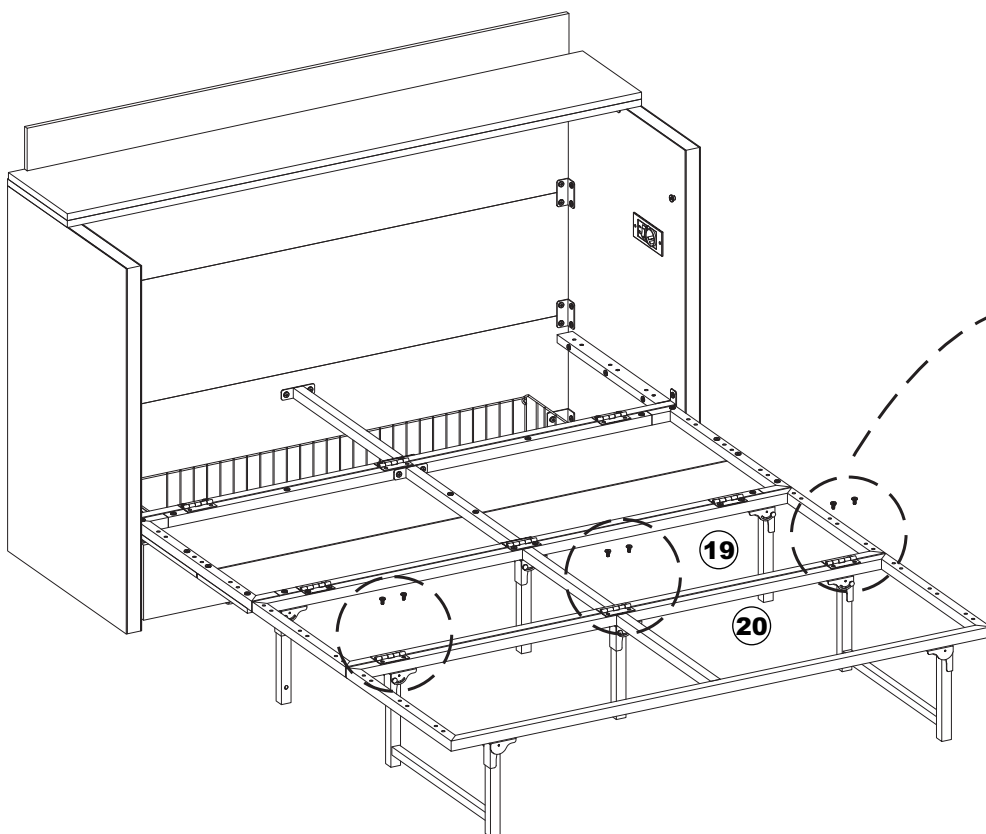

	M6x12mm
	M6x35mm
	M6x45mm
	M6x10mm

Step 28

A  **x6**
M6 x12



	M6x12mm
	M6x35mm
	M6x45mm
	M6x10mm

Step 29

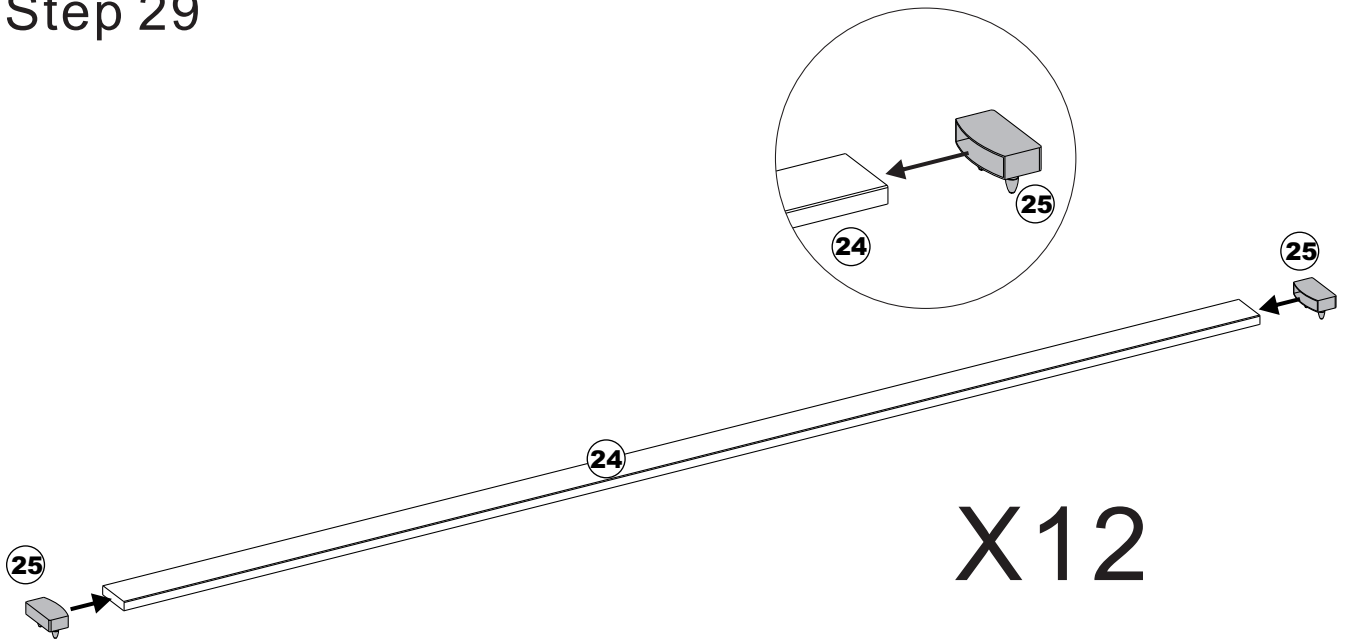

X12

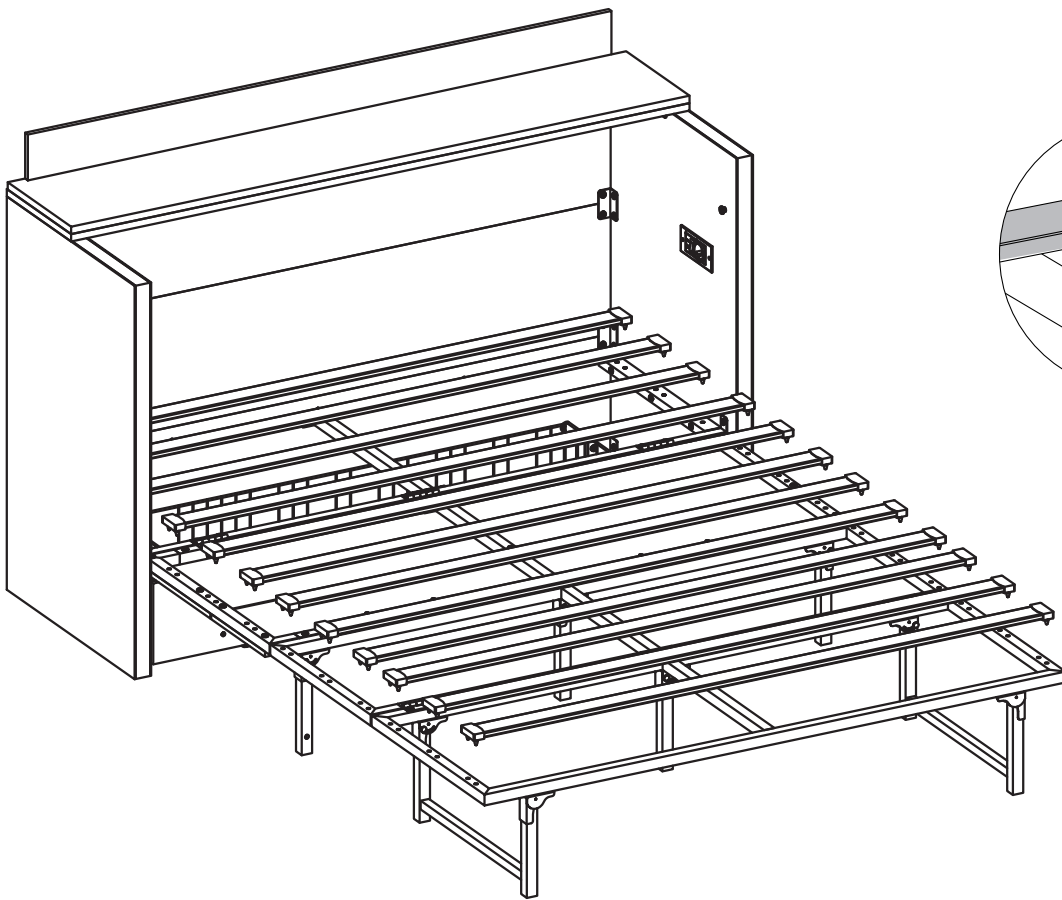

Step 30

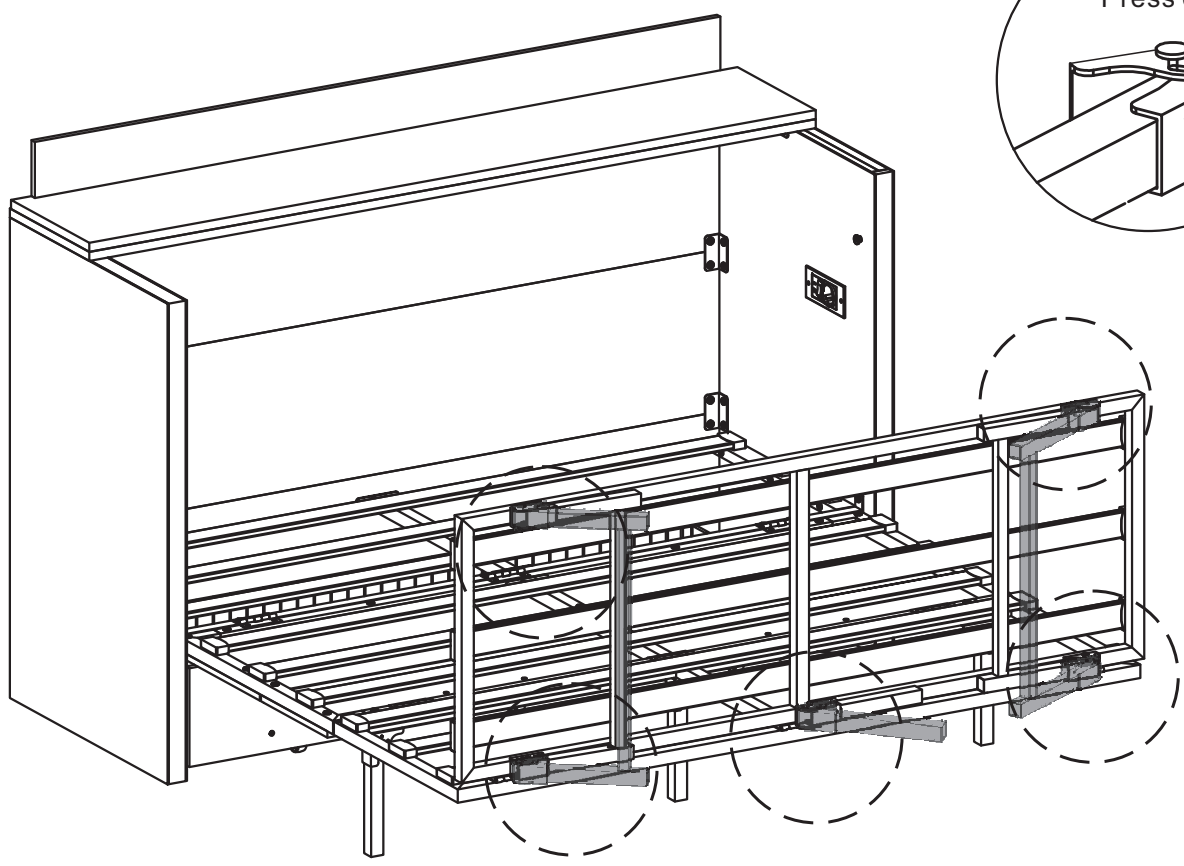
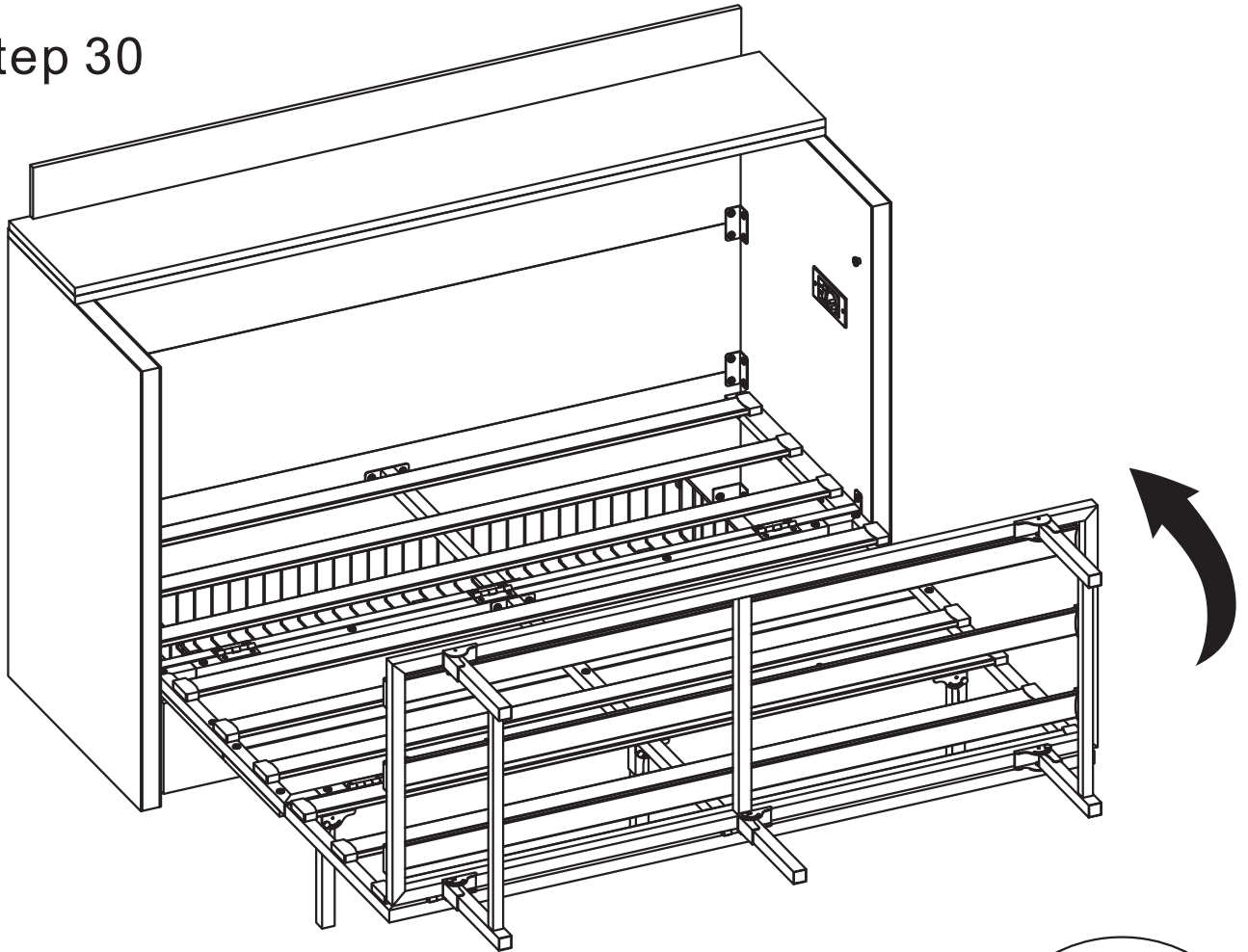

Step 31

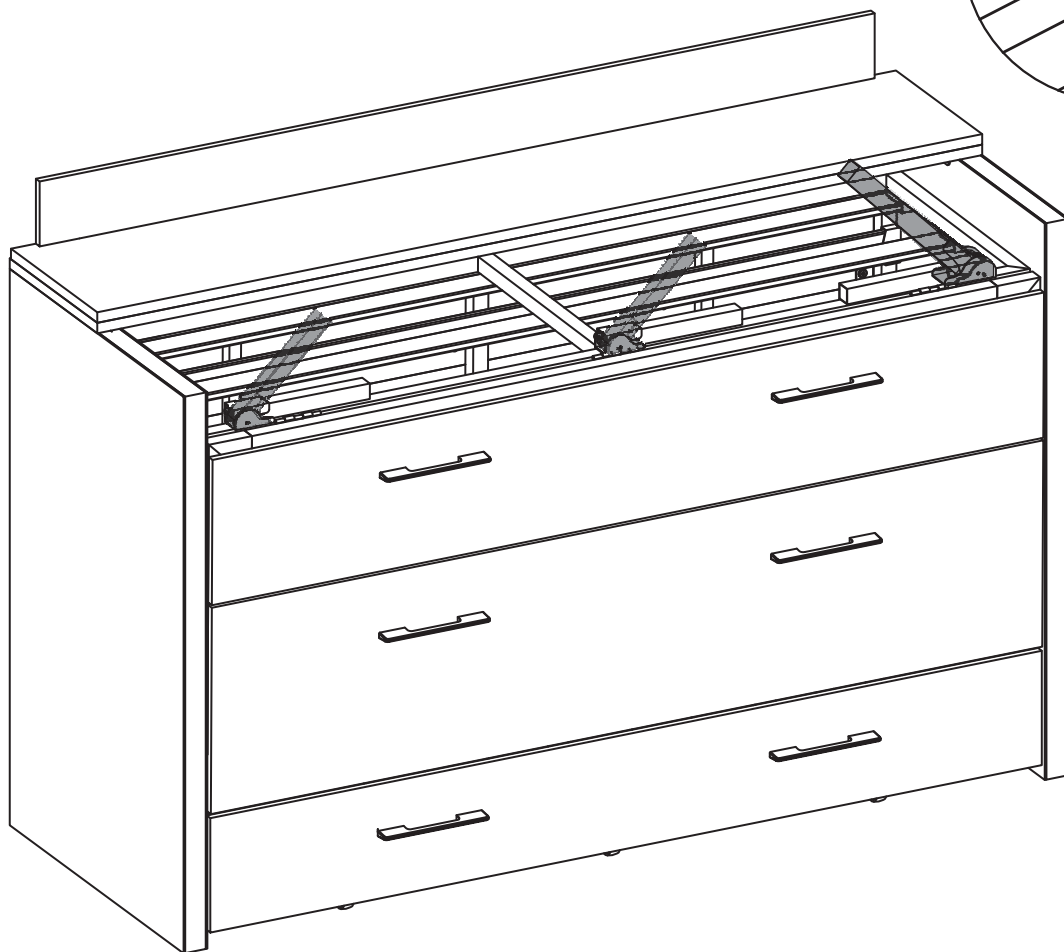
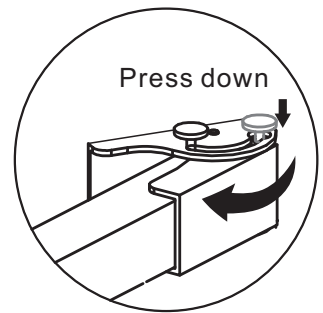
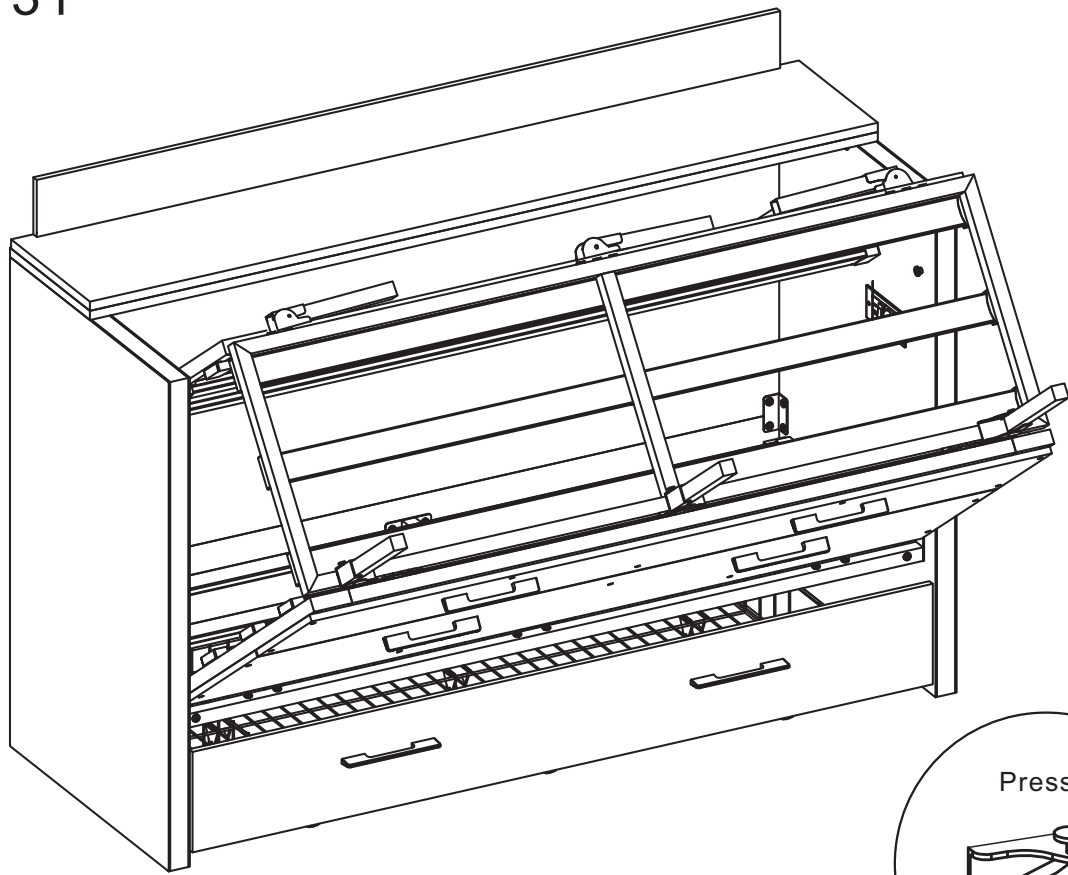

Step 32

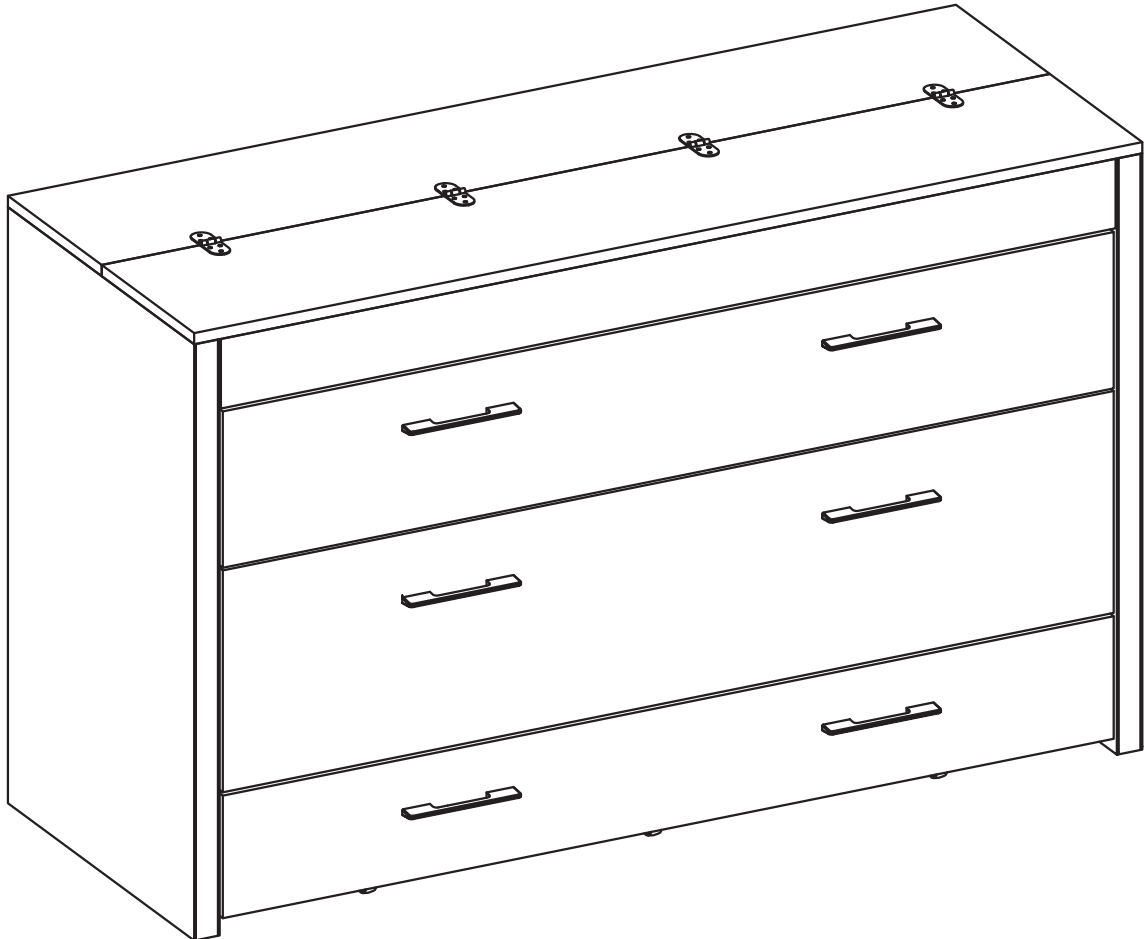
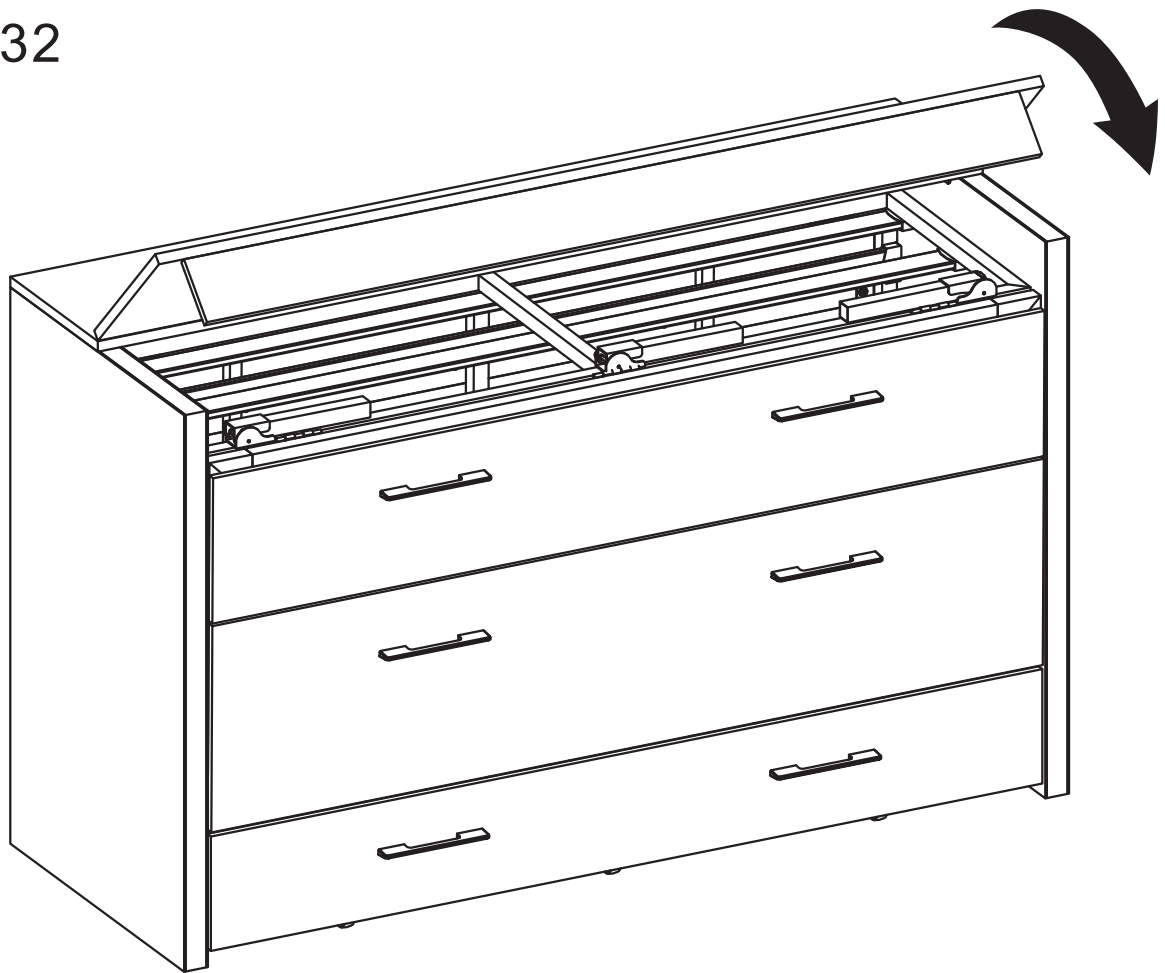

Step 33

Install against the wall and fix the fixing strap to the wall with screws

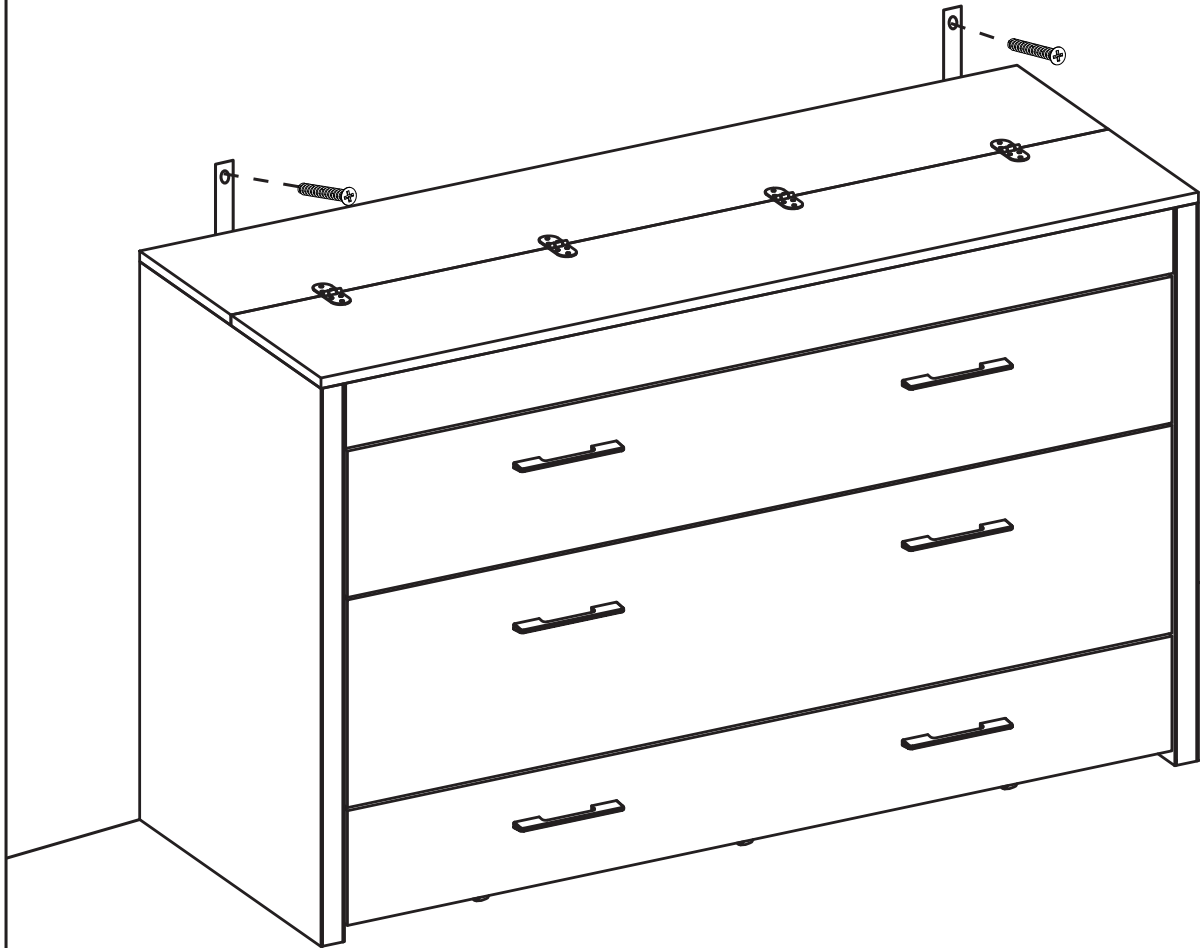

TIPS

- ① The ordinary screws are for wooden base
- ② The expansion screws with sleeve are for concrete base
The hole's diameter should not exceed 8 mm/0.32in

We recommend that you install it on a solid wall.
As we all know, the load of plaster walls is unsatisfactory.

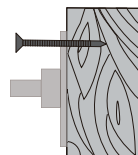

①

Wood Wall

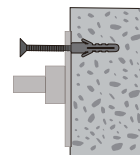

②

Concrete Wall

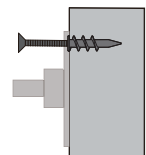

③

Drywall

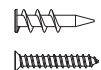

This authorizes the application of the Certification Mark(s) shown below to the models described in the Product(s) Covered section when made in accordance with the conditions set forth in the Certification Agreement and Listing Report. This authorization also applies to multiple distinct model(s) identified on the correlation page of the Listing Report.

This document is the property of Intertek Testing Services and is not transferable. The certification mark(s) may be applied only at the location of the Party Authorized To Apply Mark.

Applicant: YA LI ELECTRIC CO LTD	Manufacturer: YA LI ELECTRIC CO LTD
Address: Room 801, Building 9, No. 6, Yuyuan 4th Road Huangjiang Town, Dongguan, Guangdong, 52300	Address: Room 801, Building 9, No. 6, Yuyuan 4th Road Huangjiang Town, Dongguan, Guangdong, 52300
Country: China	Country: China
Party Authorized To Apply Mark: Same as Manufacturer	
Report Issuing Office:	Intertek Testing Services Shenzhen Limited Guangzhou Branch
Control Number: 5008876	Authorized by: _____ for L. Matthew Snyder, Certification Manager



This document supersedes all previous Authorizations to Mark for the noted Report Number.

This Authorization to Mark is for the exclusive use of Intertek's Client and is provided pursuant to the Certification agreement between Intertek and its Client. Intertek's responsibility and liability are limited to the terms and conditions of the agreement. Intertek assumes no liability to any party, other than to the Client in accordance with the agreement, for any loss, expense or damage occasioned by the use of this Authorization to Mark. Only the Client is authorized to permit copying or distribution of this Authorization to Mark and then only in its entirety. Use of Intertek's Certification mark is restricted to the conditions laid out in the agreement and in this Authorization to Mark. Any further use of the Intertek name for the sale or advertisement of the tested material, product or service must first be approved in writing by Intertek. Initial Factory Assessments and Follow up Services are for the purpose of assuring appropriate usage of the Certification mark in accordance with the agreement, they are not for the purposes of production quality control and do not relieve the Client of their obligations in this respect.

Intertek Testing Services NA Inc.
545 East Algonquin Road, Arlington Heights, IL 60005
Telephone 800-345-3851 or 847-439-5667 Fax 312-283-1672

Standard(s):	Furniture Power Distribution Units [UL 962A:2023 Ed.6] Cord Reels and Multi-outlet Assemblies [CSA C22.2#308:2018 Ed.2]
Product:	Furniture power distribution unit
Brand Name:	YA LI
Models:	YL-SKUL-601, YL-SKUL-601A, YL-SKUL-602, YL-SKUL-603, YL-SKUL-605, YL-SKUL-605A, YL-SKUL-606, YL-SKUL-606A, YL-SKUL-607, YL-SKUL-608, YL-SKUL-609, YL-SKUL-609A, YL-SKUL-609B, YL-SKUL-610, YL-SKUL-610A, YL-SKUL-610-20W, YL-SKUL-611A, YL-SKUL-611B, YL-SKUL-611C, YL-SKUL-612B, YL-SKUL-612C, YL-SKUL-612D, YL-SKUL-613, YL-SKUL-615, YL-SKUL-615A, YL-SKUL-615B, YL-SKUL-615C, YL-SKUL-615-20W, YL-SKUL-617, YL-SKUL-618, YL-SKUL-619, YL-SKUL-620

Importeur	Decobus Handel GmbH
Adresse	Innungsstraße 9,21244 Buchholz, Deutschland
Email/URL	https://www.decobusgroup.de
Hersteller	Dongguan Yali Elektrotechnik Co., Ltd.
Adresse	Huangjiang Stadt, Dongguan, Guangdong Yuyuan Industriegebiet Yuyuan 4. Straße 6, Maomingde Industriepark
Email/URL	38053076@qq.com
Partienummer	20250716-08
Hergestellt in	CHINA
	Decobus Handel GmbH Innungsstraße 9,21244 Buchholz, Deutschland https://www.decobusgroup.de



Produkt: Steckdose + USB + TYPE-C
 Modell: YL-SKCE-902A
 Nennspannung: 250V 10A
 Nennfrequenz: USB-A 5V 2.1A TYPE-C 5V 2.1A
 Leistung: 2500W



FR
 Cet appareil,
 ses cordons,
 et batterie
 se recyclent

À DÉPOSER
 EN MAGASIN

OU

À DÉPOSER
 EN DÉCHÈTERIE

Points de collecte sur www.quefairedemesdechets.fr
 Privilégiez la réparation ou le don de votre appareil !