

Montageanleitung | Instructions de montage Assembly Instructions | Instrucciones de montaje

N623P412710/N623P412711/N623P412712

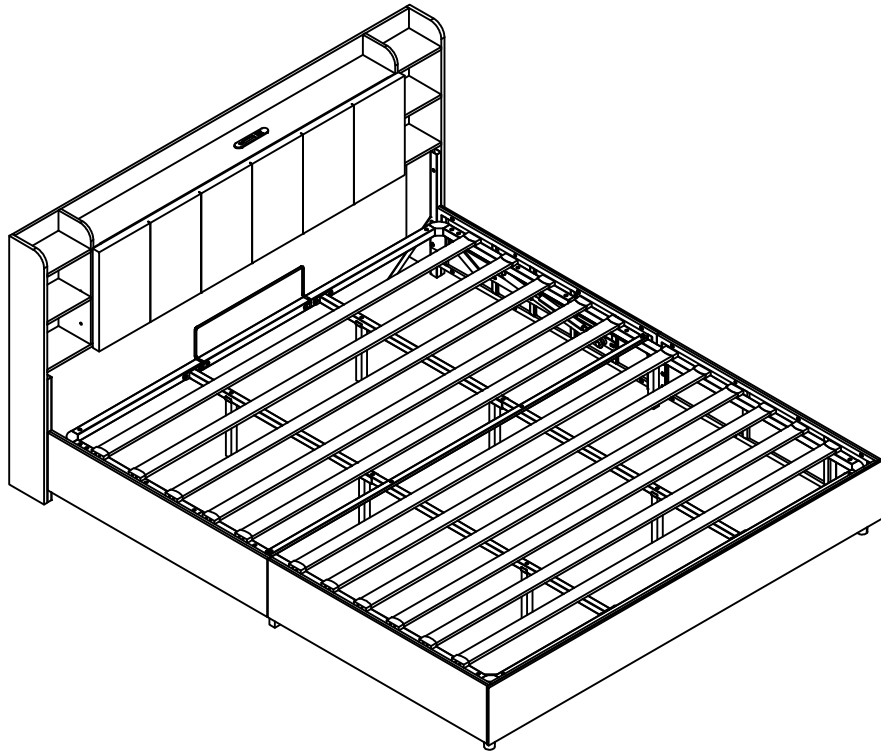

- GB** This set comes in 3 boxes. If you do not receive a full set of 3 boxes, please contact our customer service.
- DE** Dieses Set wird in 3 Schachteln geliefert. Wenn Sie nicht ein komplettes Set von 3 Boxen erhalten, kontaktieren Sie bitte unseren Kundenservice.
- FR** Ce set est livré en 3 boîtes. Si vous ne recevez pas un jeu complet de 3 boîtes, veuillez contacter notre service clientèle.

English

IMPORTANT FOR GAS LIFT BEDS&MAINTAINANCE

- Please place the mattress on top of the bed frame.
- Please do not pull on the strap handles.
- Please press heavily to release the compressed gas.
- Periodically check all screw & fixings to ensure they are secure.
- When moving your product, carefully lift into place.
- Wipe clean with a slightly damp cloth- please do not use abrasive chemicals or bleach.
- Do NOT allow children to operate the lift mechanism.
- Do NOT allow children near the lift base when operating the mechanism.
- Do NOT stand inside the bed or the internal storage base.
- Do NOT overload the internal storage base.
- DO NOT jump on the product or any of its parts.

Deutsch

WICHTIG FÜR GASLIFT-BETTEN&WARTUNG

- Bitte legen Sie die Matratze oben auf den Bettrahmen.
- Bitte ziehen Sie nicht an den Gurtgriffen.
- Bitte drücken Sie kräftig, um das komprimierte Gas freizusetzen.
- Überprüfen Sie regelmäßig alle Schrauben und Befestigungen, um sicherzustellen, dass sie sicher sind.
- Wenn Sie Ihr Produkt bewegen, heben Sie es vorsichtig an seinen Platz.
- Mit einem leicht feuchten Tuch abwischen - bitte keine scheuernden Chemikalien oder Bleichmittel verwenden.
- Erlauben Sie Kindern NICHT, den Hebemechanismus zu bedienen.
- Lassen Sie Kinder NICHT in die Nähe des Liftsockels, wenn Sie den Mechanismus bedienen.
- Stellen Sie sich NICHT in das Bett oder in die Innenablage.
- Überlasten Sie den internen Liftsockel NICHT.
- Springen Sie NICHT auf das Produkt oder eines seiner Teile.

Français

IMPORTANT POUR LES LITS À RELEVAGE DE GAZ&MAINTENANCE

- Veuillez placer le matelas sur le dessus du cadre de lit.
- Ne tirez pas sur les poignées de la sangle.
- Appuyez fortement pour libérer le gaz comprimé.
- Vérifiez régulièrement que toutes les vis et fixations sont bien en place.
- Lorsque vous déplacez votre produit, soulevez-le avec précaution pour le mettre en place.
- Nettoyez avec un chiffon légèrement humide - n'utilisez pas de produits chimiques abrasifs ou d'eau de Javel.
- Ne laissez pas les enfants utiliser le mécanisme de levage.
- Ne laissez pas les enfants s'approcher de la base de levage lorsqu'ils actionnent le mécanisme.
- Ne vous tenez PAS à l'intérieur du lit ou de la base de stockage interne.
- Ne surchargez pas la base de stockage interne.
- Ne pas sauter sur le produit ou l'une de ses parties.

Italiano

IMPORTANTE PER I LETTI CON SOLLEVAMENTO A GAS E LA MANUTENZIONE

- Posizionare il materasso sopra la struttura del letto.
- Non tirare le maniglie della cinghia.
- Premere con forza per rilasciare il gas compresso.
- Controllare periodicamente tutte le viti e i fissaggi per assicurarsi che siano saldi.
- Quando si sposta il prodotto, sollevarlo con cautela.
- Pulire con un panno leggermente umido, senza usare prodotti chimici abrasivi o candeggina.
- NON permettere ai bambini di azionare il meccanismo di sollevamento.
- NON permettere ai bambini di avvicinarsi alla base di sollevamento quando si aziona il meccanismo.
- NON sostare all'interno del letto o della base di contenimento interna.
- NON sovraccaricare la base di contenimento interna.
- NON saltare sul prodotto o sulle sue parti.

Español

IMPORTANTE PARA LAS CAMAS ELEVADORAS DE GAS&MANTENIMIENTO

- Coloque el colchón sobre el somier.
- No tire de las asas de la correa.
- Presione con fuerza para liberar el gas comprimido.
- Compruebe periódicamente que todos los tornillos y fijaciones estén bien sujetos.
- Al mover el producto, levántelo con cuidado para colocarlo en su sitio.
- Limpie con un paño ligeramente humedecido; no utilice productos químicos abrasivos ni lejía.
- NO permita que los niños accionen el mecanismo de elevación.
- NO permita que los niños se acerquen a la base elevadora cuando accionen el mecanismo.
- NO se ponga de pie dentro de la cama o de la base de almacenamiento interna.
- NO sobrecargue el somier.
- NO salte sobre el producto ni sobre ninguna de sus piezas.

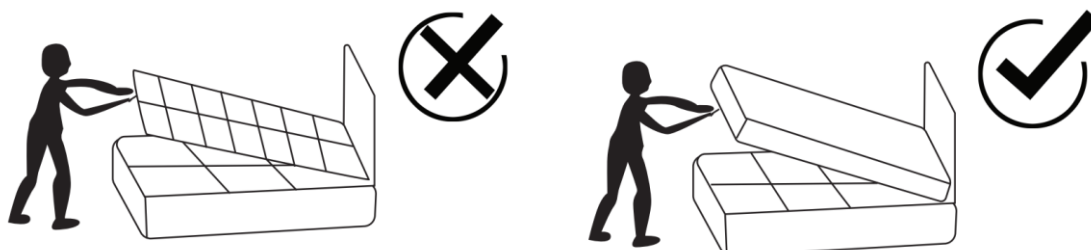

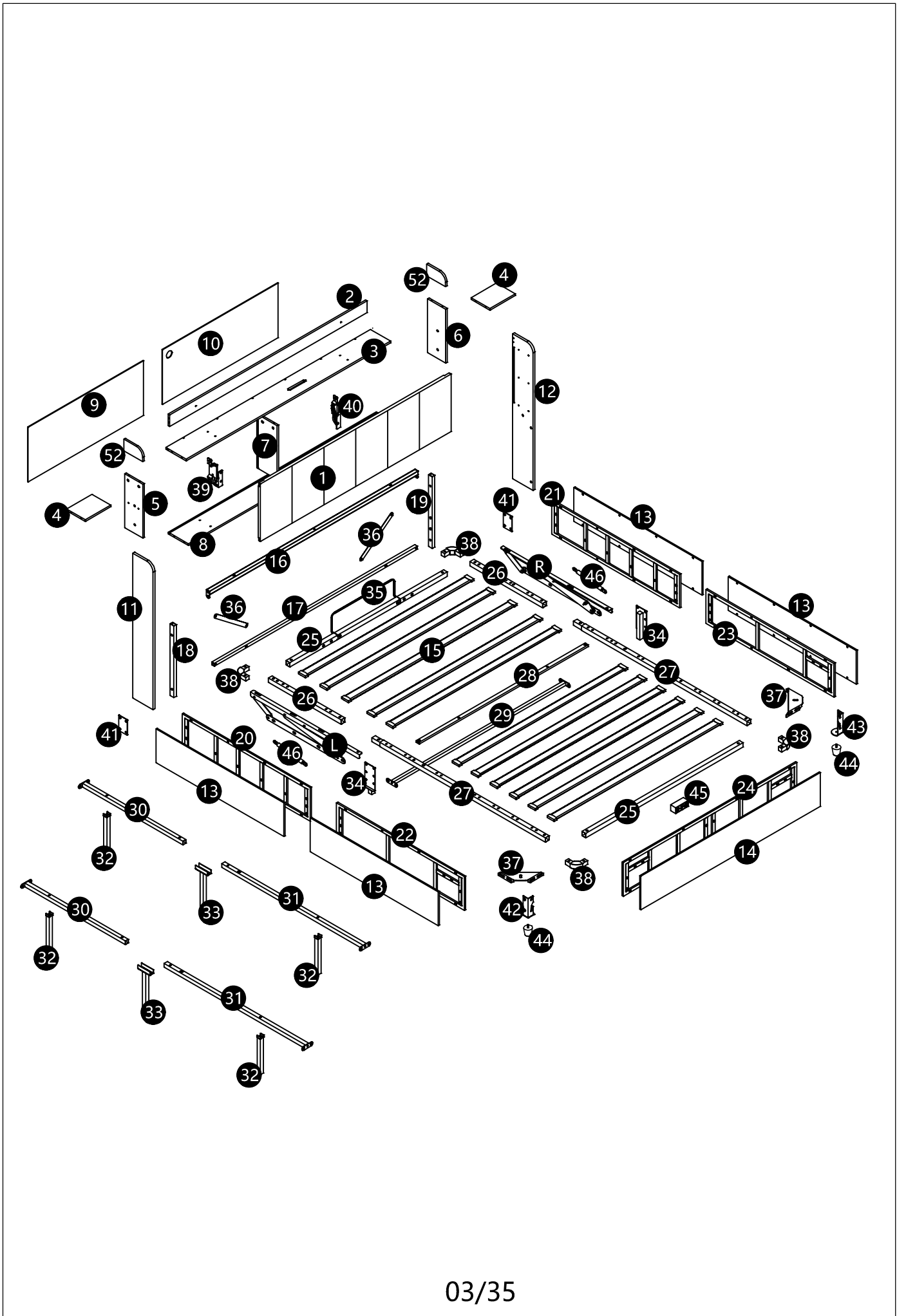



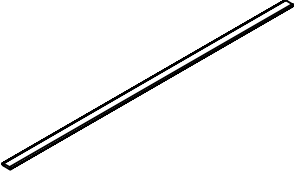
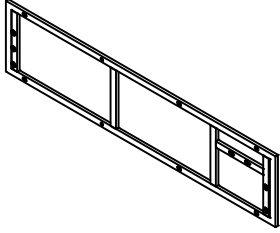
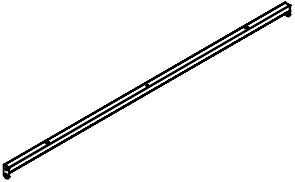
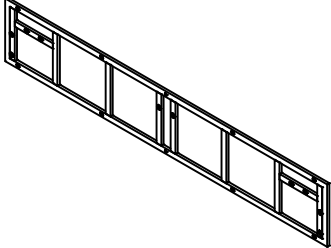
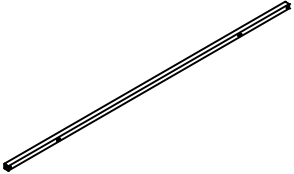
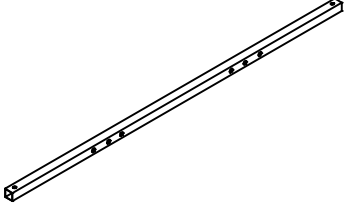
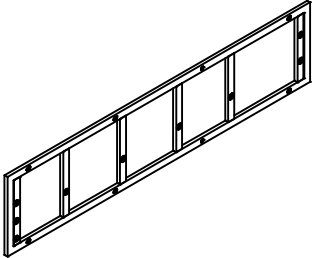
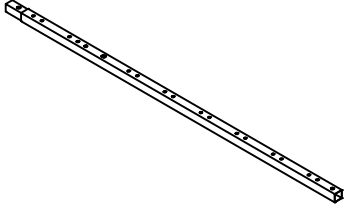
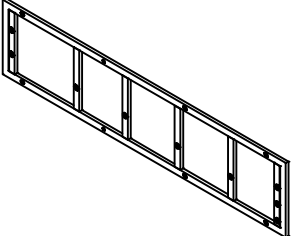
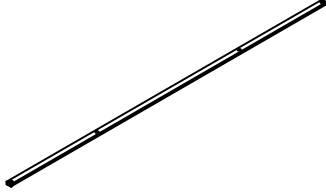
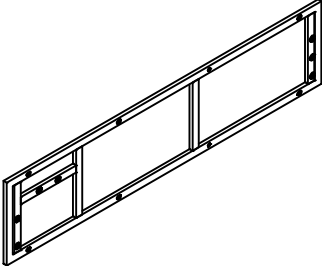
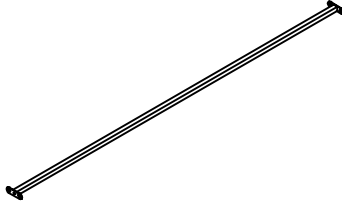

N623P412710

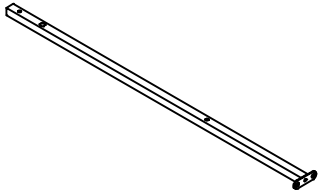
15		X11	23		X1
16		X1	24		X1
17		X1	25		X2
20		X1	27		X2
21		X1	28		X1
22		X1	29		X1



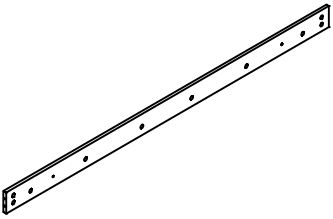
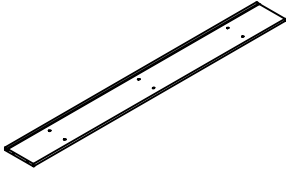
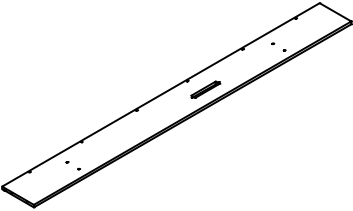

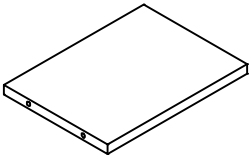

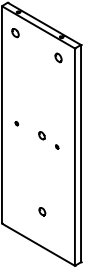
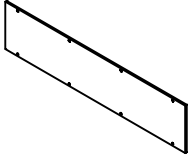
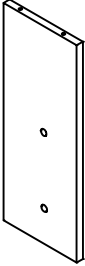
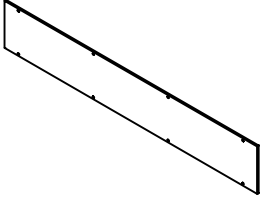
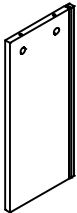
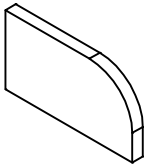
N623P412710

31		X2			

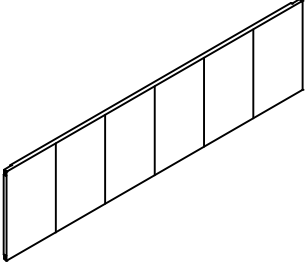
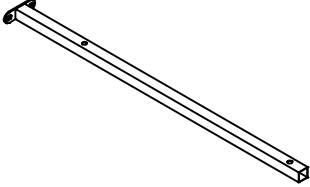
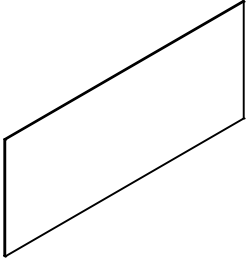

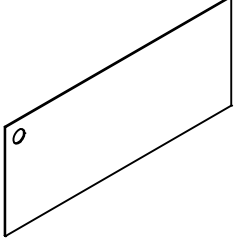
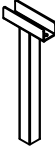
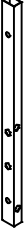

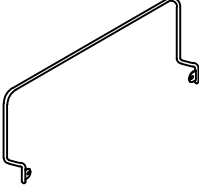
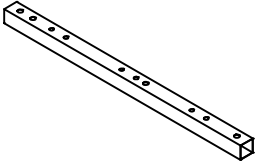
N623P412711

<p>2</p>		<p>X1</p>	<p>8</p>		<p>X1</p>
<p>3</p>		<p>X1</p>	<p>11</p>		<p>X1</p>
<p>4</p>		<p>X2</p>	<p>12</p>		<p>X1</p>
<p>5</p>		<p>X1</p>	<p>13</p>		<p>X4</p>
<p>6</p>		<p>X1</p>	<p>14</p>		<p>X1</p>
<p>7</p>		<p>X1</p>	<p>52</p>		<p>X2</p>

N623P412712

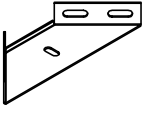
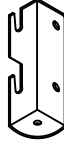
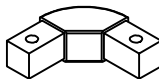
<p>1</p>		<p>X1</p>	<p>30</p>		<p>X2</p>
<p>9</p>		<p>X1</p>	<p>32</p>		<p>X4</p>
<p>10</p>		<p>X1</p>	<p>33</p>		<p>X2</p>
<p>18</p>		<p>X1</p>	<p>34</p>		<p>X2</p>
<p>19</p>		<p>X1</p>	<p>35</p>		<p>X1</p>
<p>26</p>		<p>X2</p>	<p>36</p>		<p>X2</p>

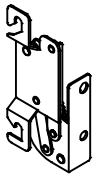
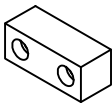
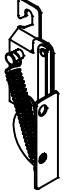
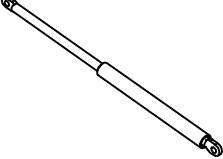
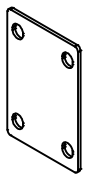
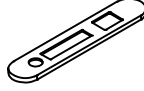
N623P412712

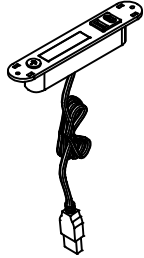



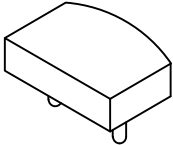
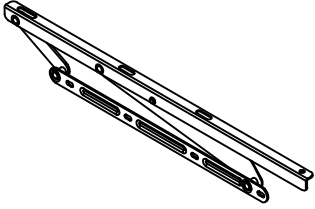
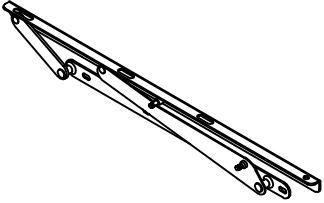









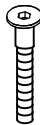

37		X2	43		X1
38		X4	44		X2
39		X1	45		X1
40		X1	46		X2
41		X2	47		X1
42		X1	48		X1

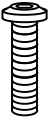
N623P412712

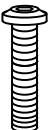
50		X1			
51		X22			
L		X1			
R		X1			





Hardware List-Hardware-Liste-Liste du matériel

N623P412712

A	 M8*12	X14+1	G	 M6*34	X3+1	N	 M8* ϕ 22	X10+1
B	 M8*13	X62+2	H	 M5*35	X12+8	O	 M8	X12+1
C	 M8*25	X2+1	J	 M3*12	X2+1	P		X8+1
D	 M8*35	X14+1	K	 M3*16	X8+1	Q	 M5	X1
E	 M8*45	X8+1	L	 X32+3	X32+3	R	 M6	X1
F	 M6*18	X42+2	M	 X32+3	X32+3	S	 M8	X1

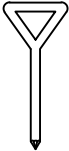
Hardware List-Hardware-Liste-Liste du matériel

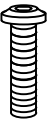
N623P412712

T		X1						
U		X1						
V	 M8*30	X4+1						
W	 Silent sticker	X4+1						

1

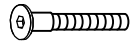

M5*35
HX4pcs



M5
QX1pc

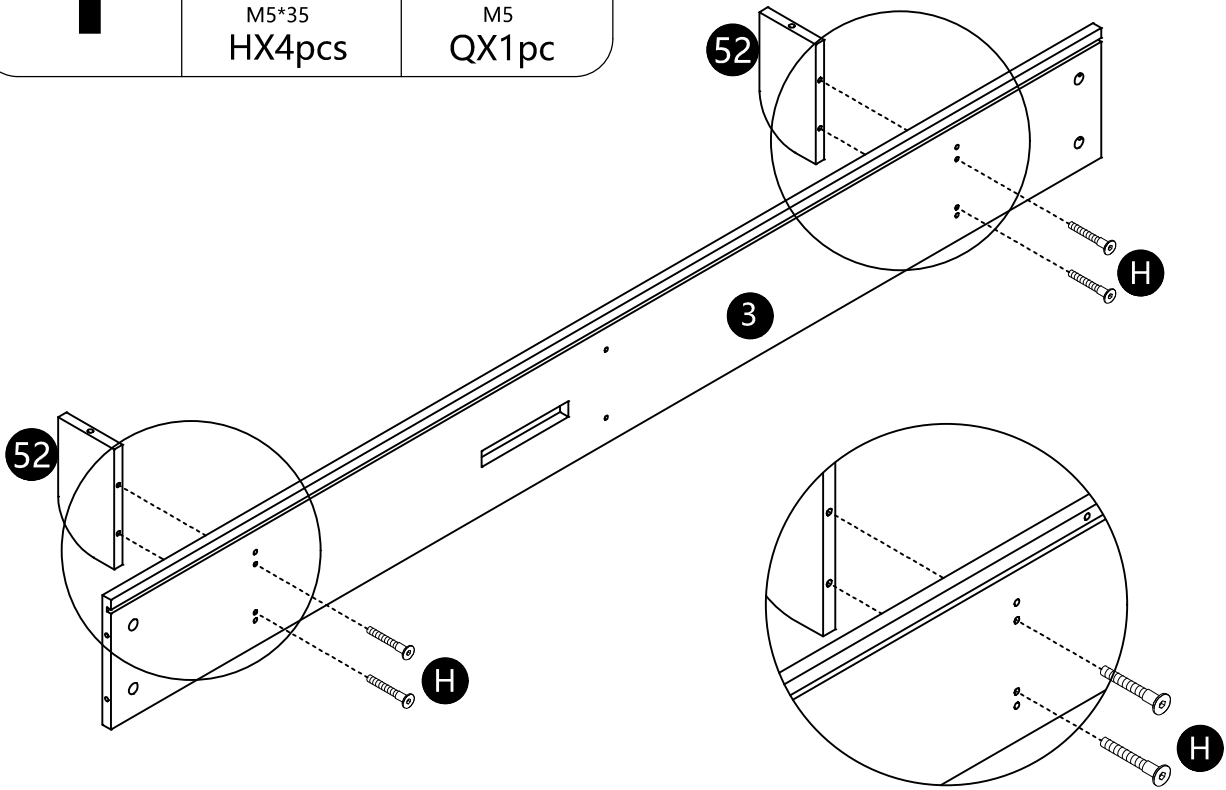

2

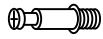

LX6pcs

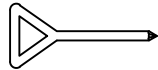

TX1pc

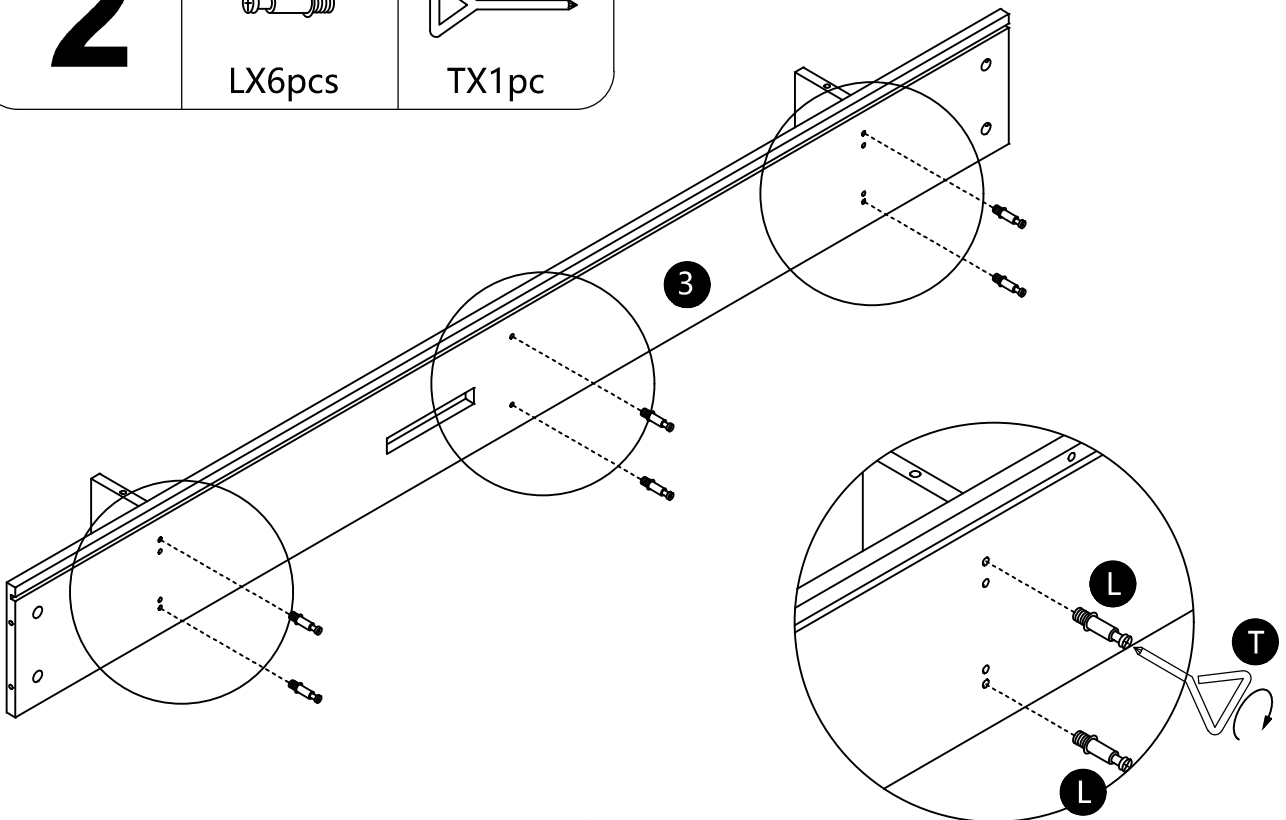

3

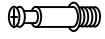

LX4pcs

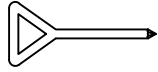

TX1pc

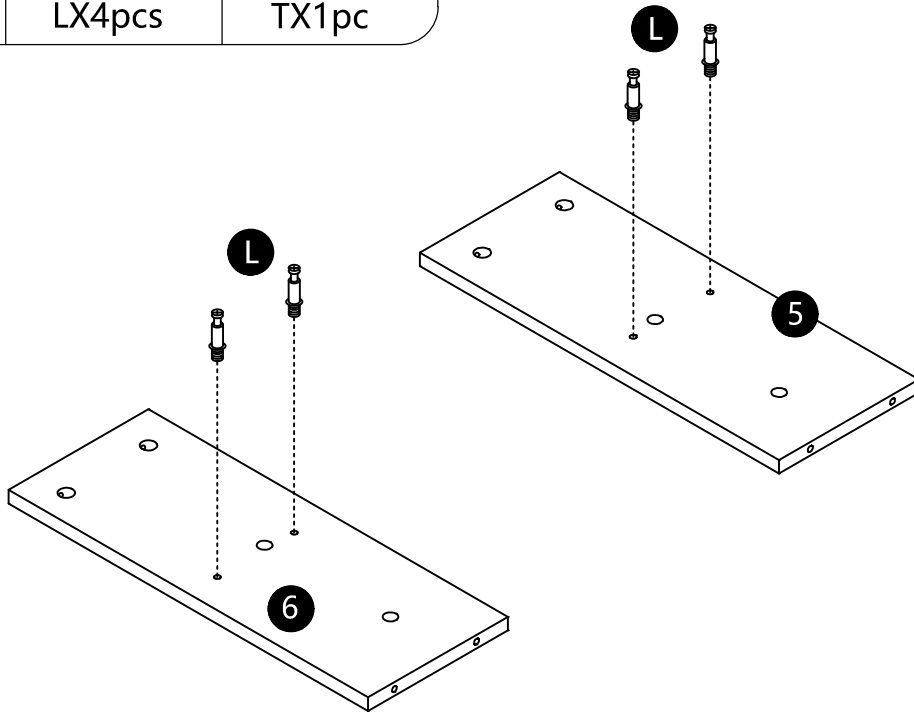

4



MX6pcs

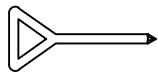

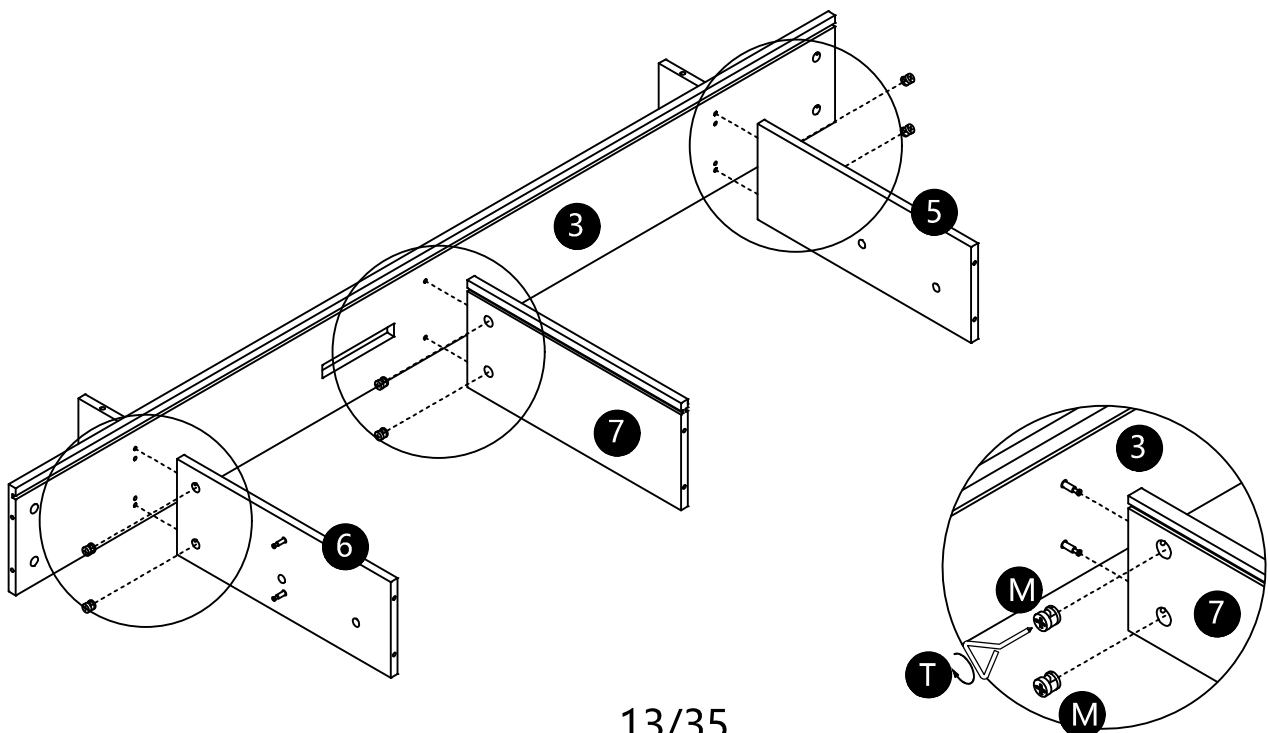
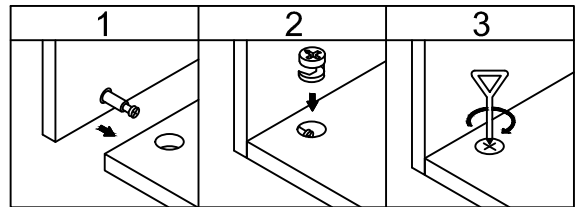

TX1pc

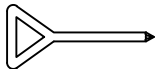

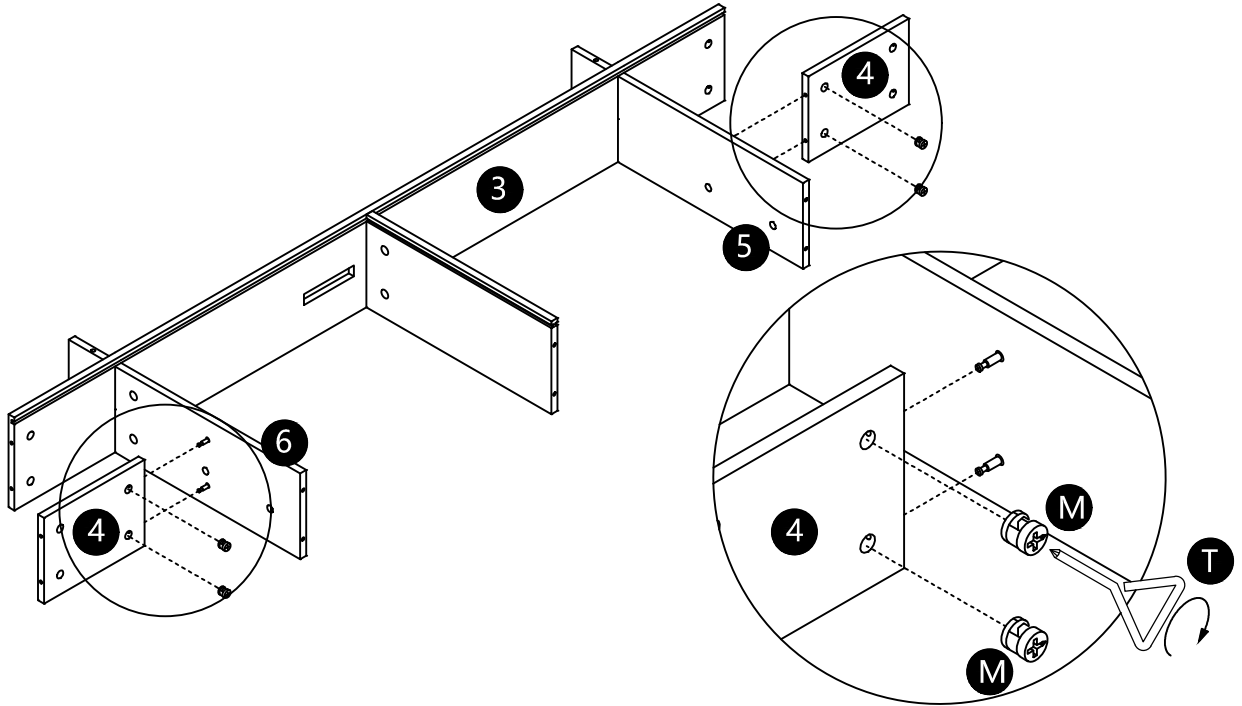
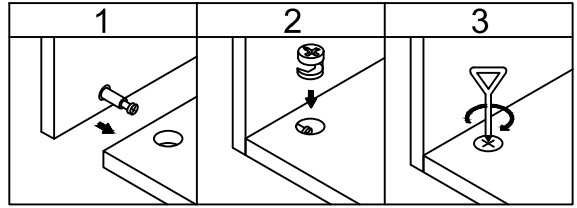
<h1>5</h1>	 MX4pcs	 TX1pc
------------	---	--

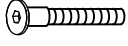

<h1>6</h1>	 M5*35 HX6pcs	 M5 QX1pc
------------	--	--

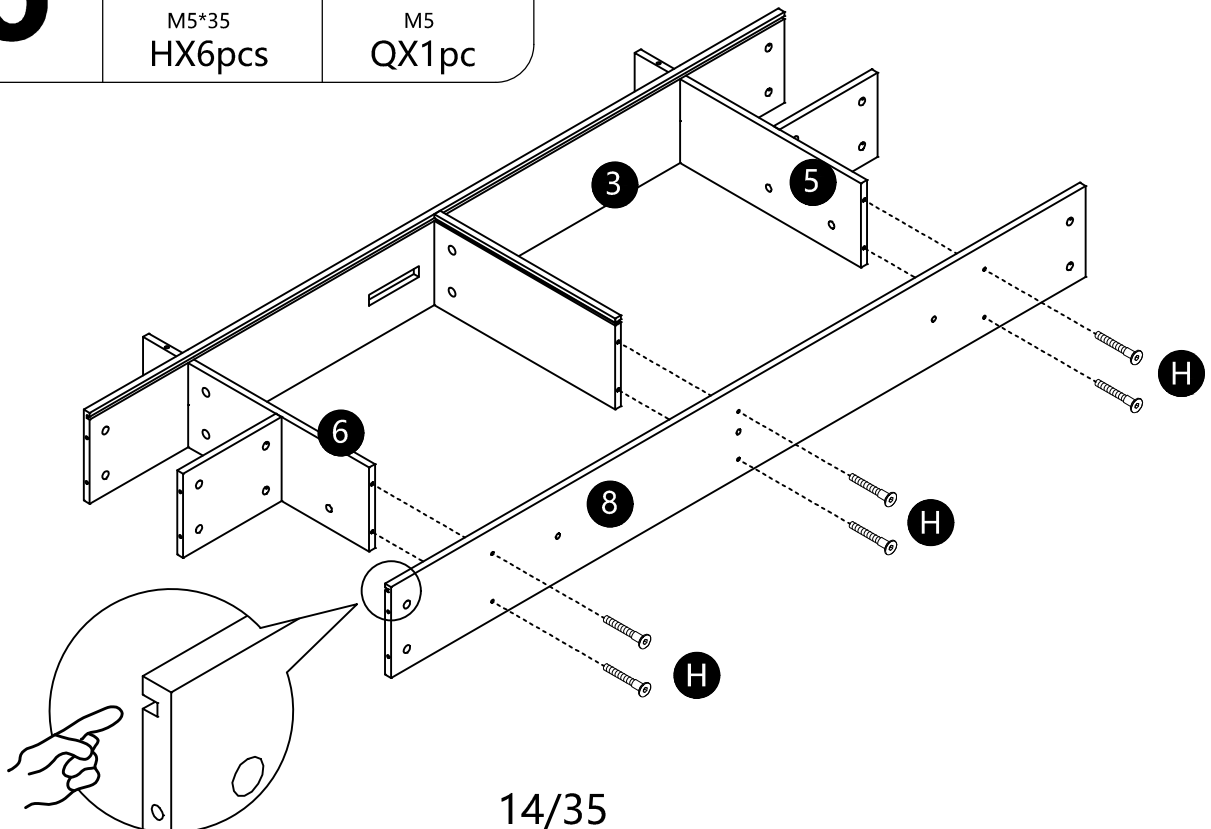

7

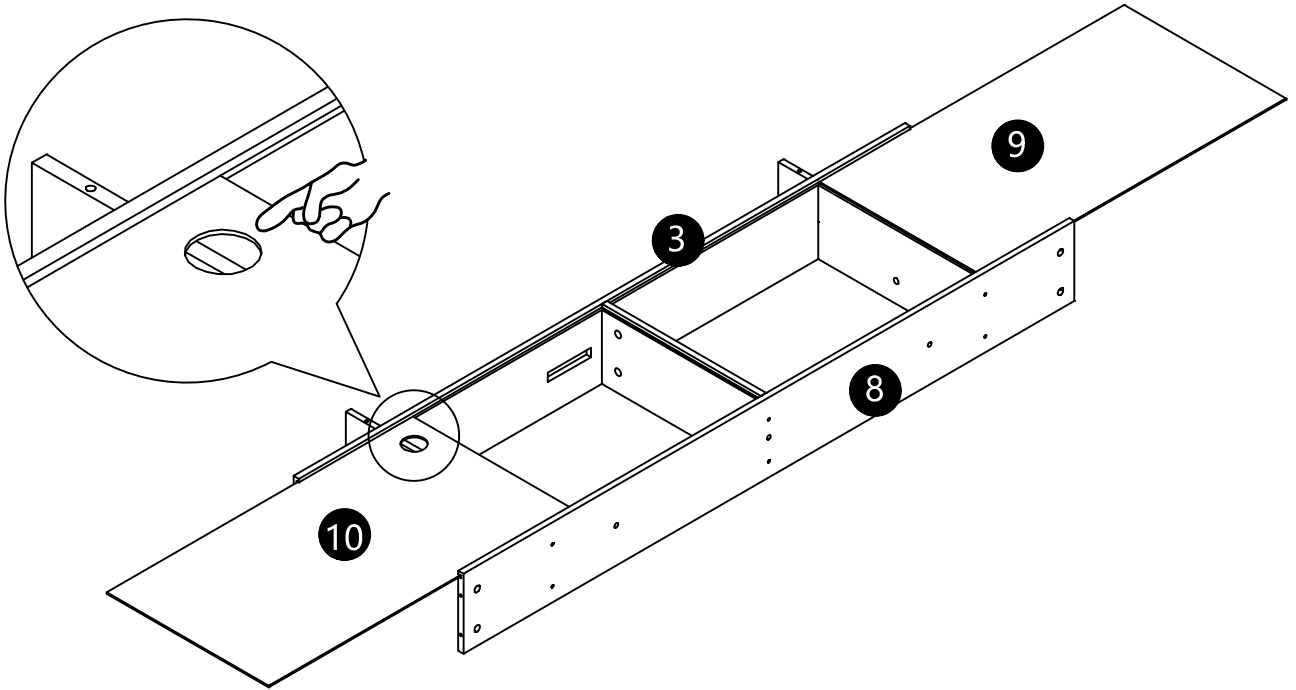

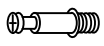
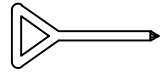
8	 LX6pcs	 TX1pc
---	---	--

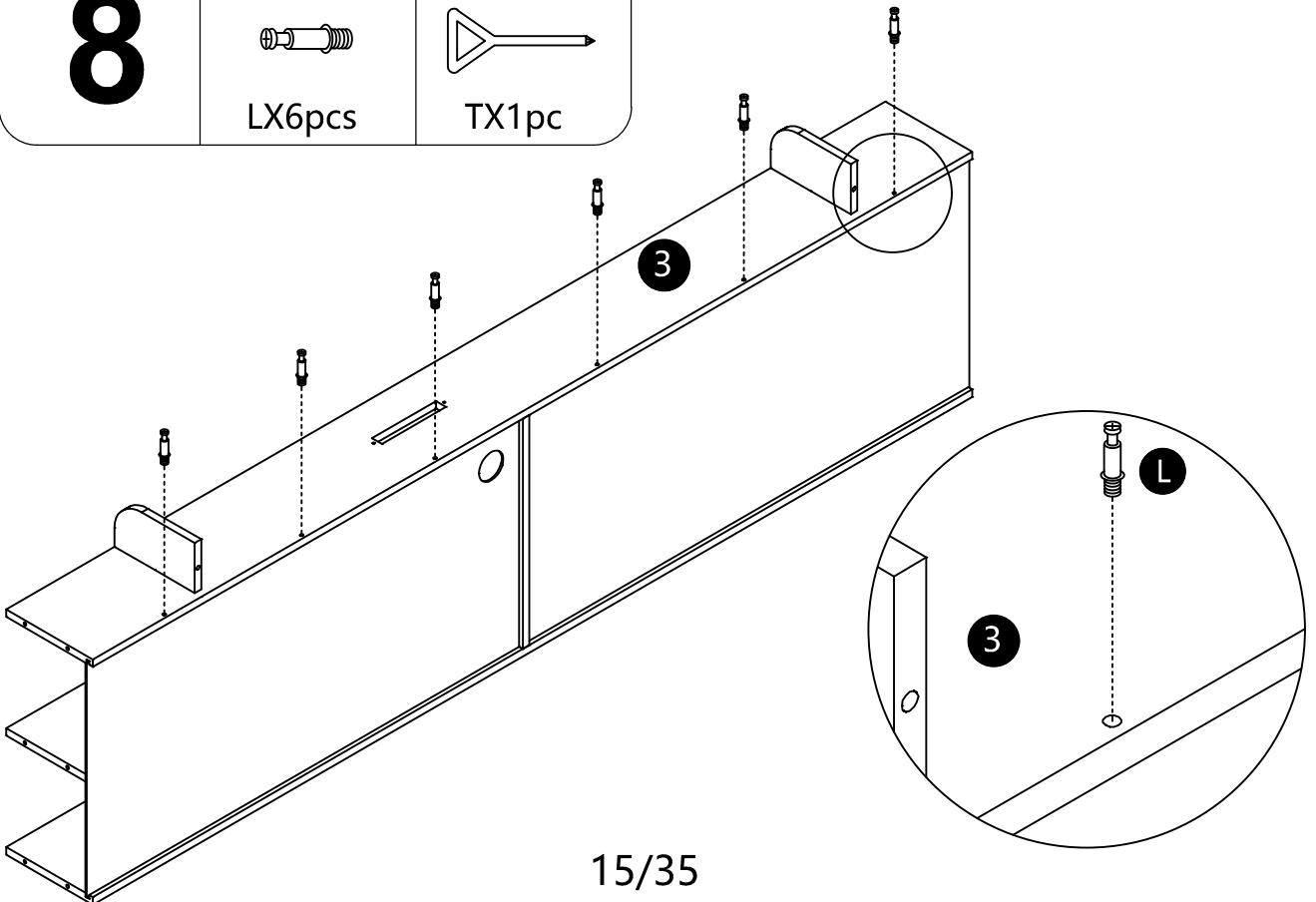

9



MX6pcs

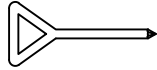

TX1pc

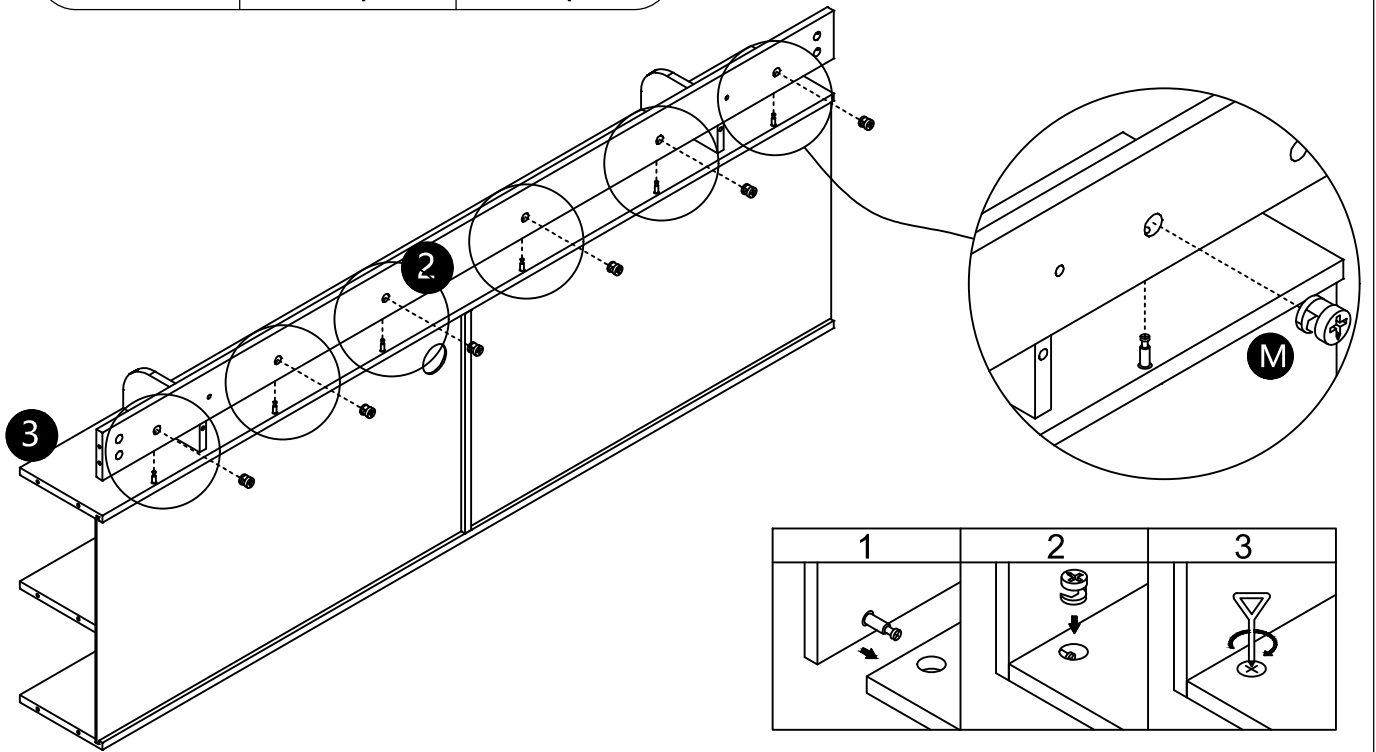

10

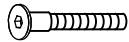

M5*35
HX2pcs



M5
QX1pc

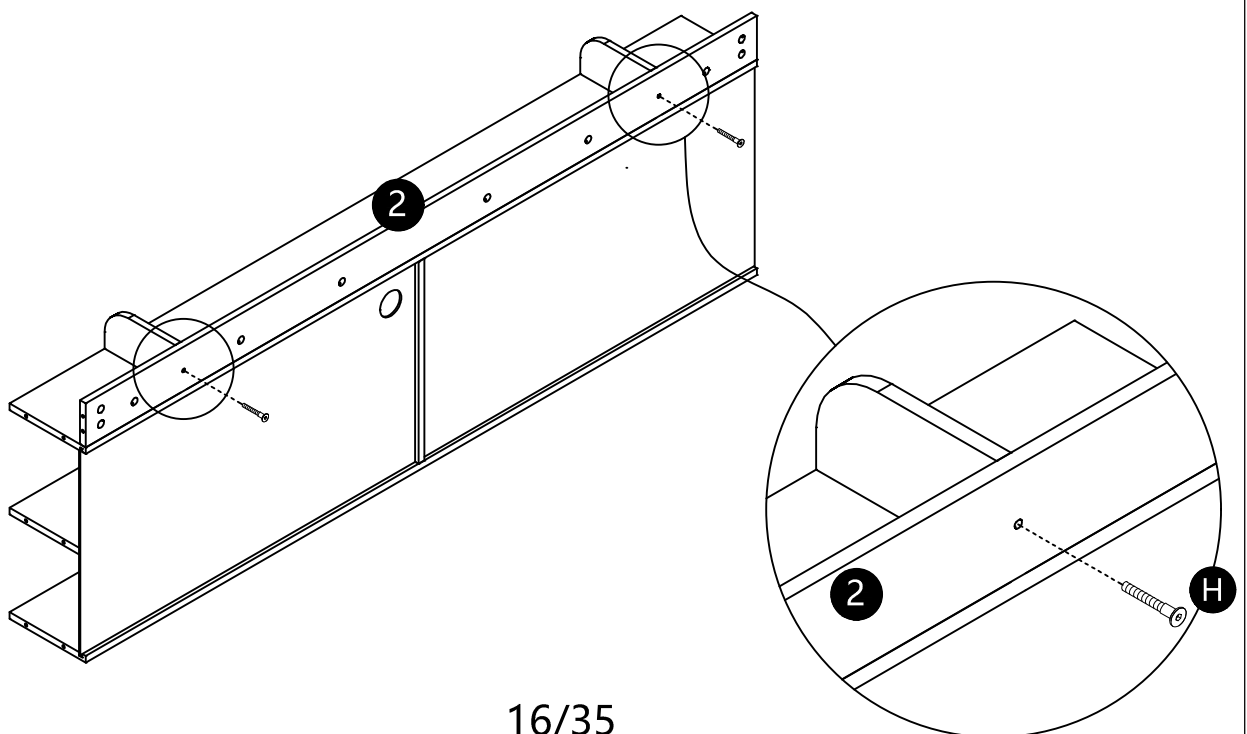

11

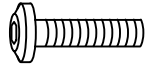

M6*34
GX3pcs



M6
RX1pc

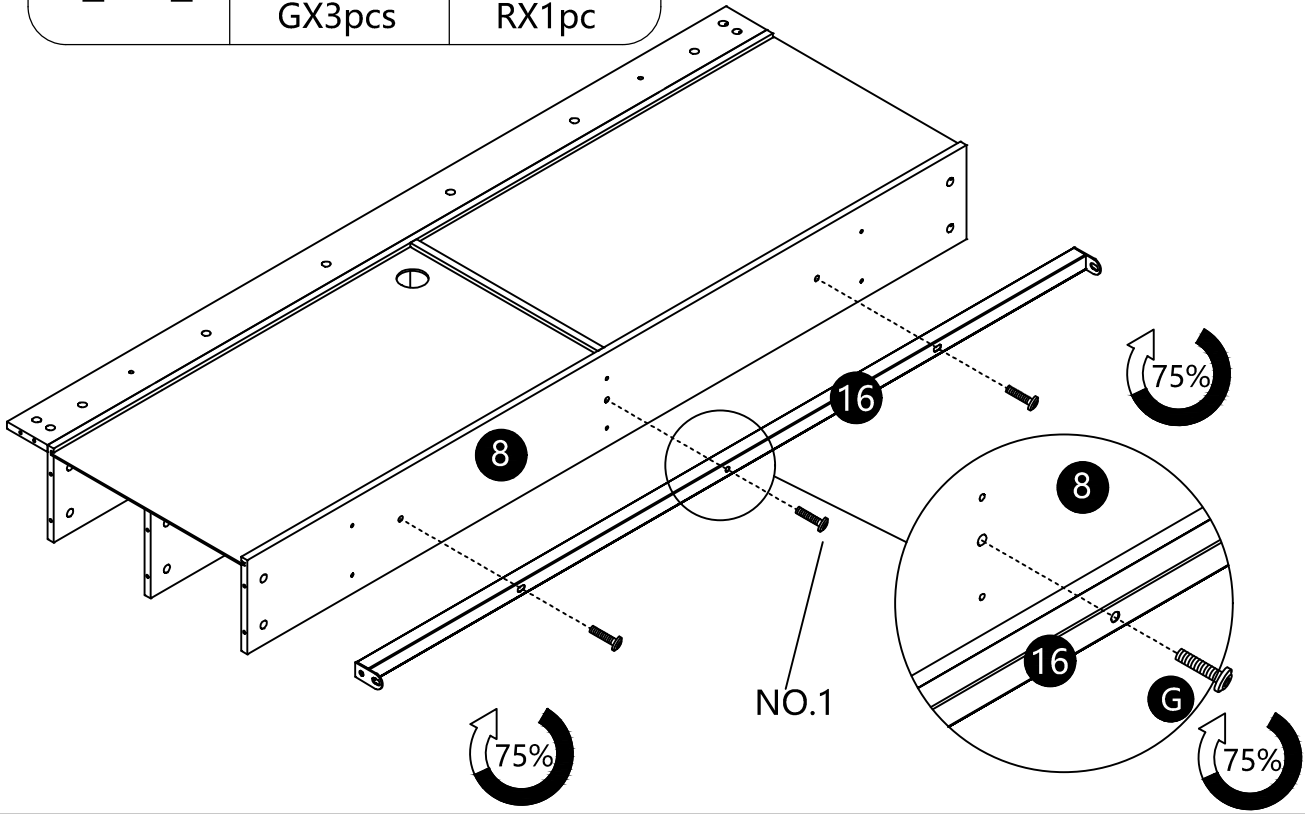

12



M8X30
VX4pcs



M8
SX1pc

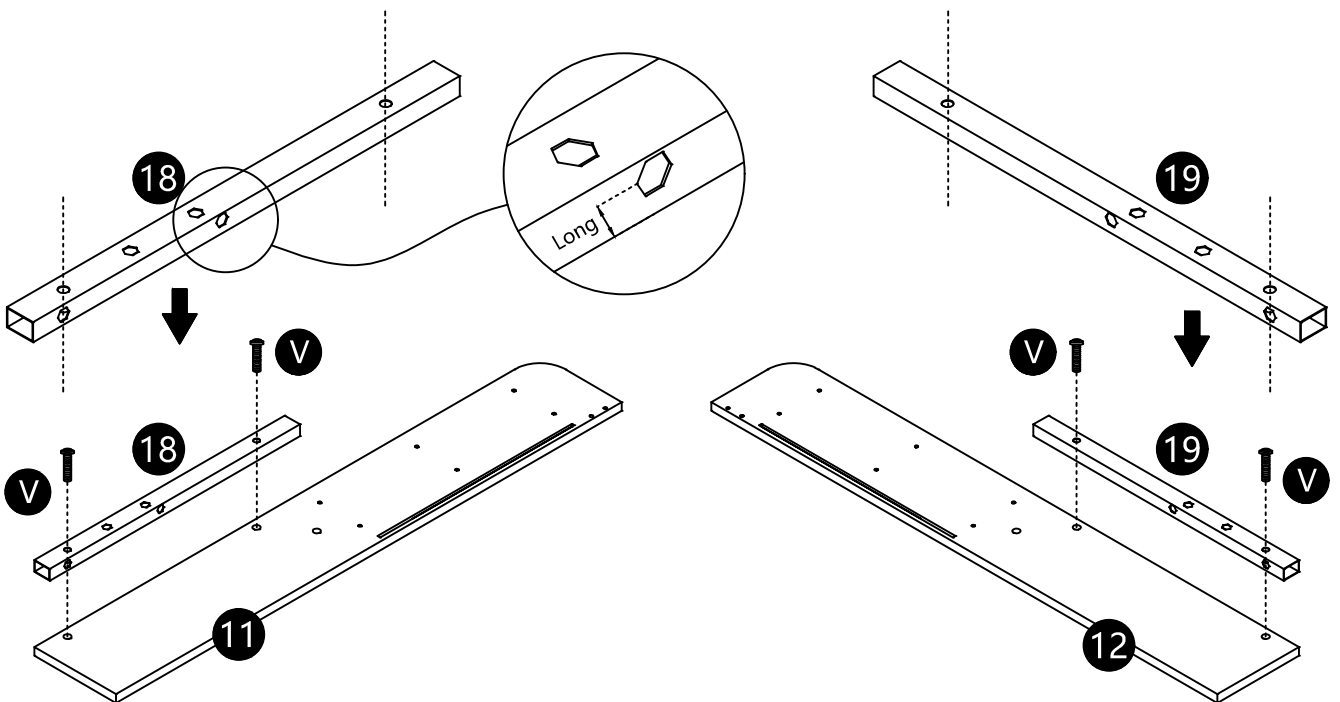

13

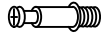

LX16pcs

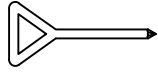

TX1pc

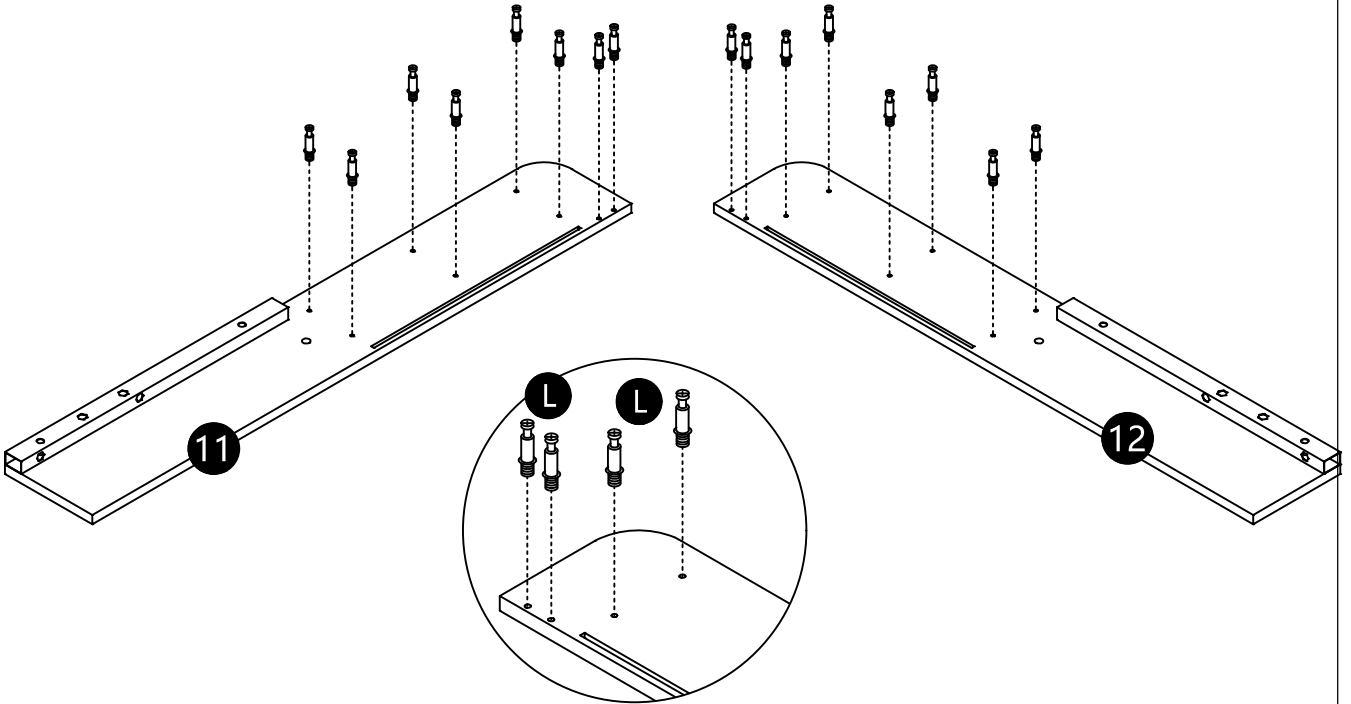

14

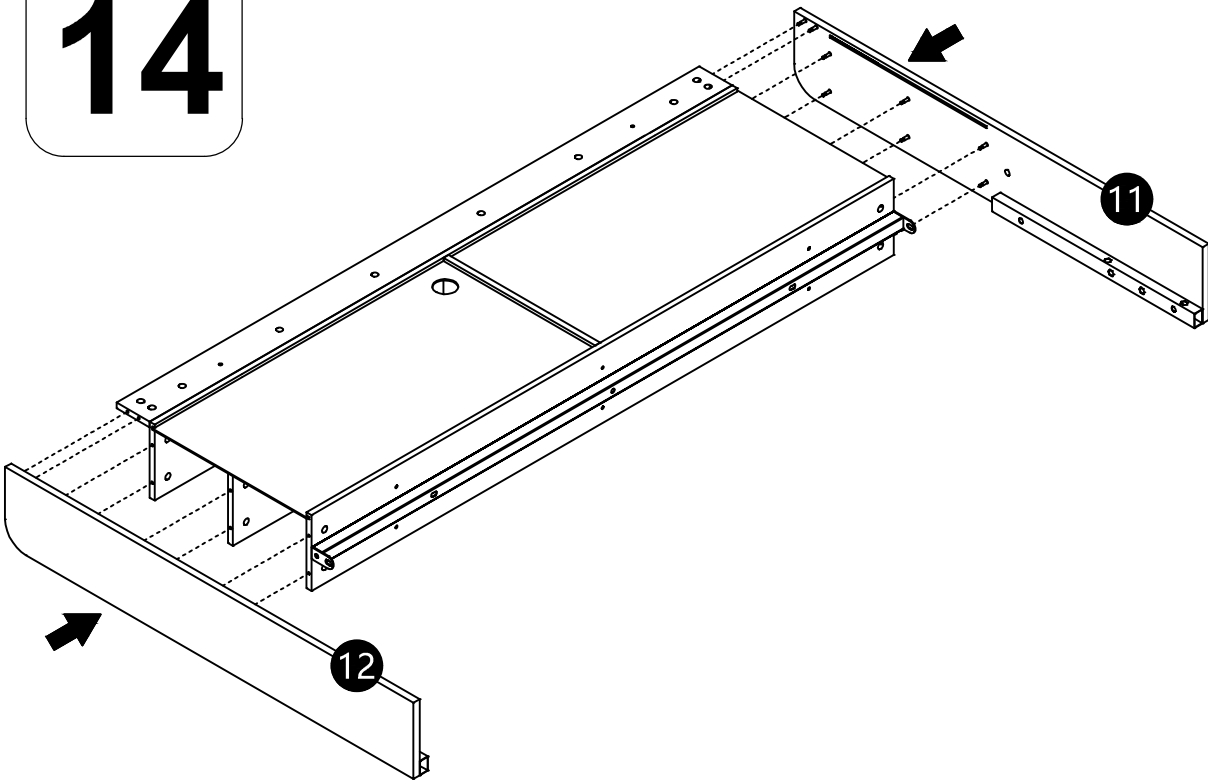

15



M8X12
AX2pcs



M8
SX1pc

NO.1

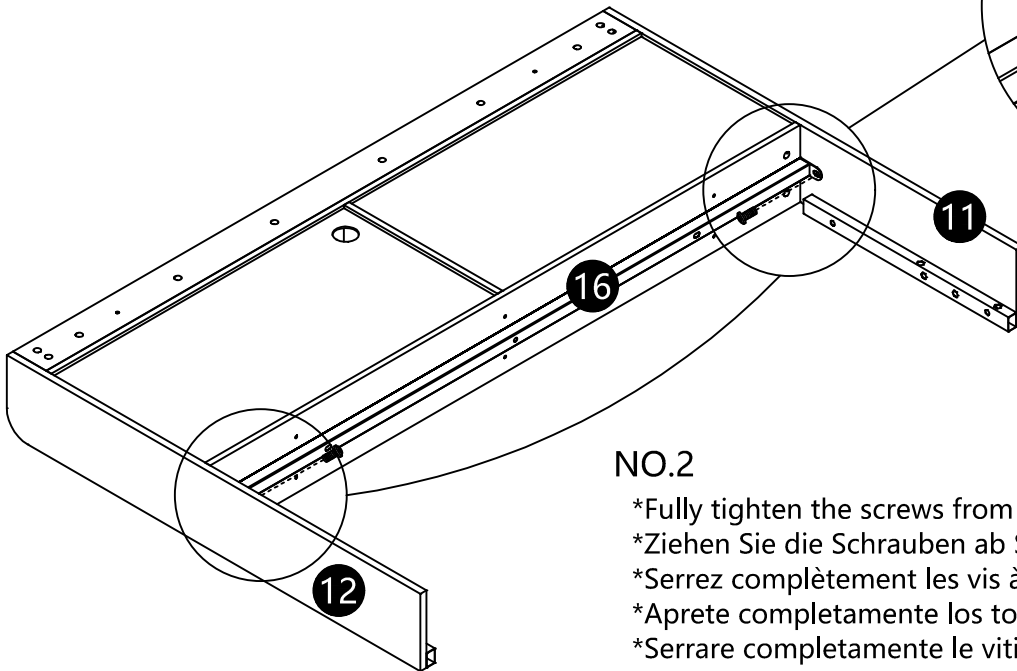
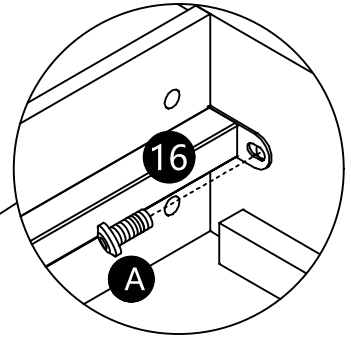

NO.2

- *Fully tighten the screws from step 11
- *Ziehen Sie die Schrauben ab Schritt 11 vollständig an
- *Serrez complètement les vis à partir de l'étape 11
- *Aprete completamente los tornillos desde el paso 11
- *Serrare completamente le viti dal passo 11

16



MX4pcs

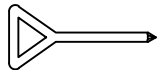

TX1pc

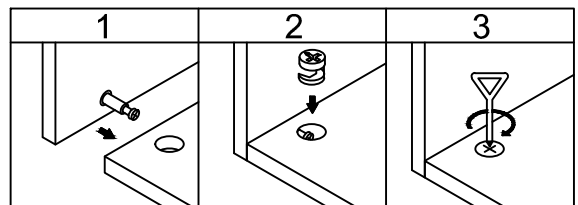
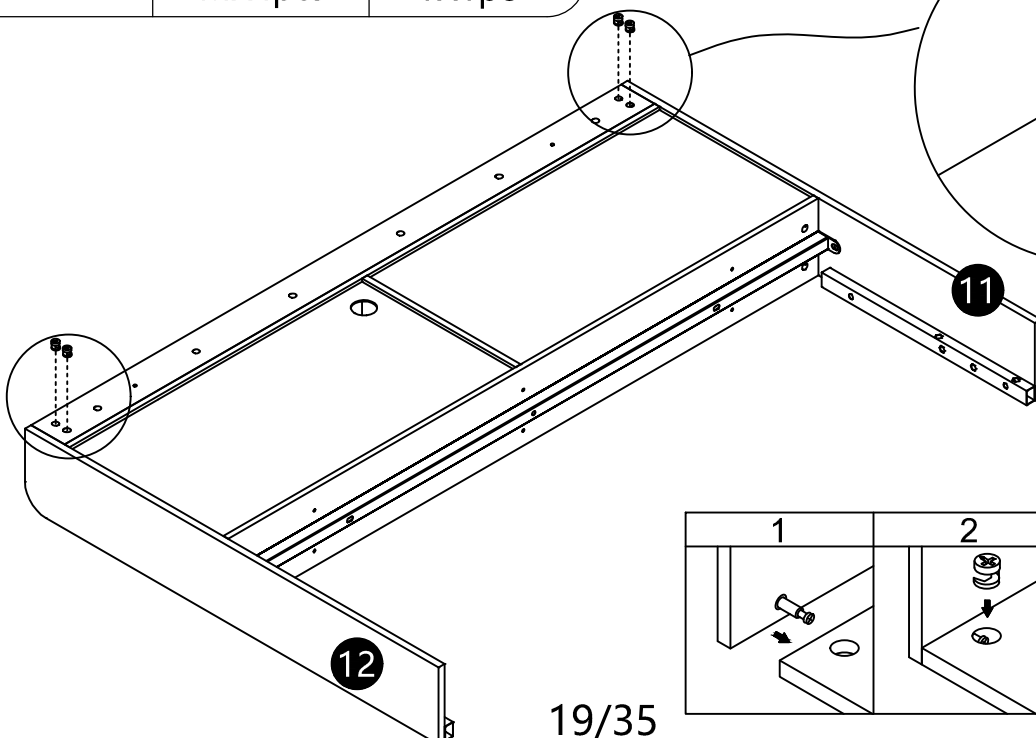
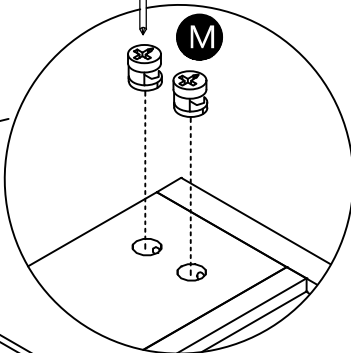

17



MX4pcs

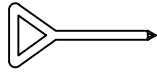

TX1pc

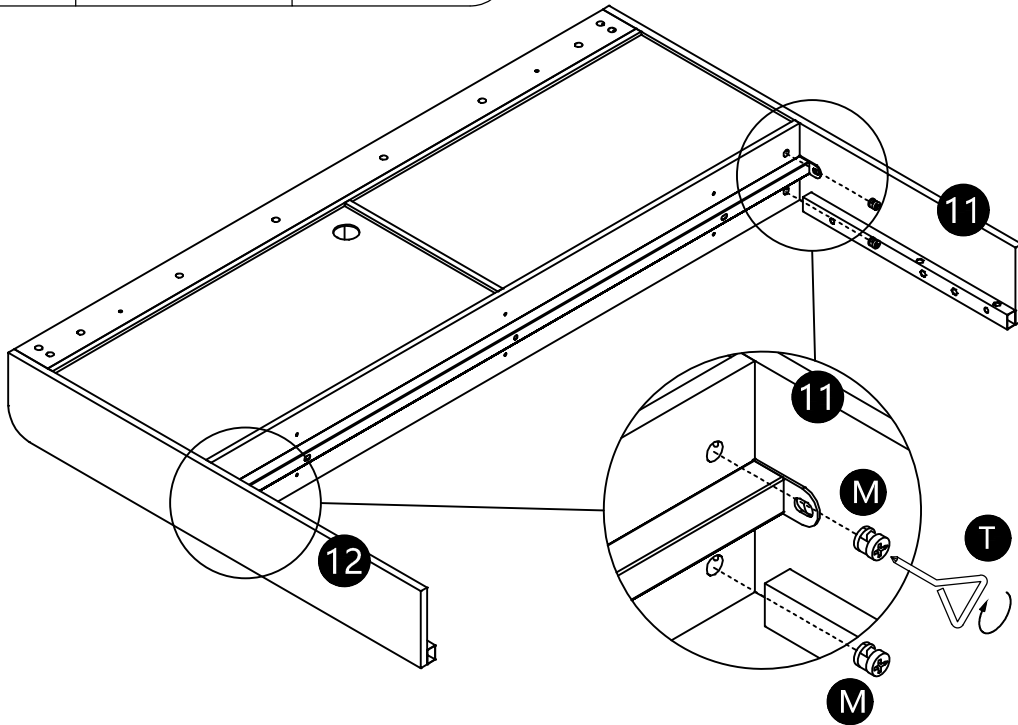
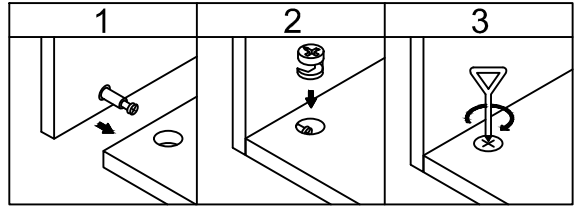

18



MX8pcs

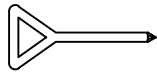

TX1pc

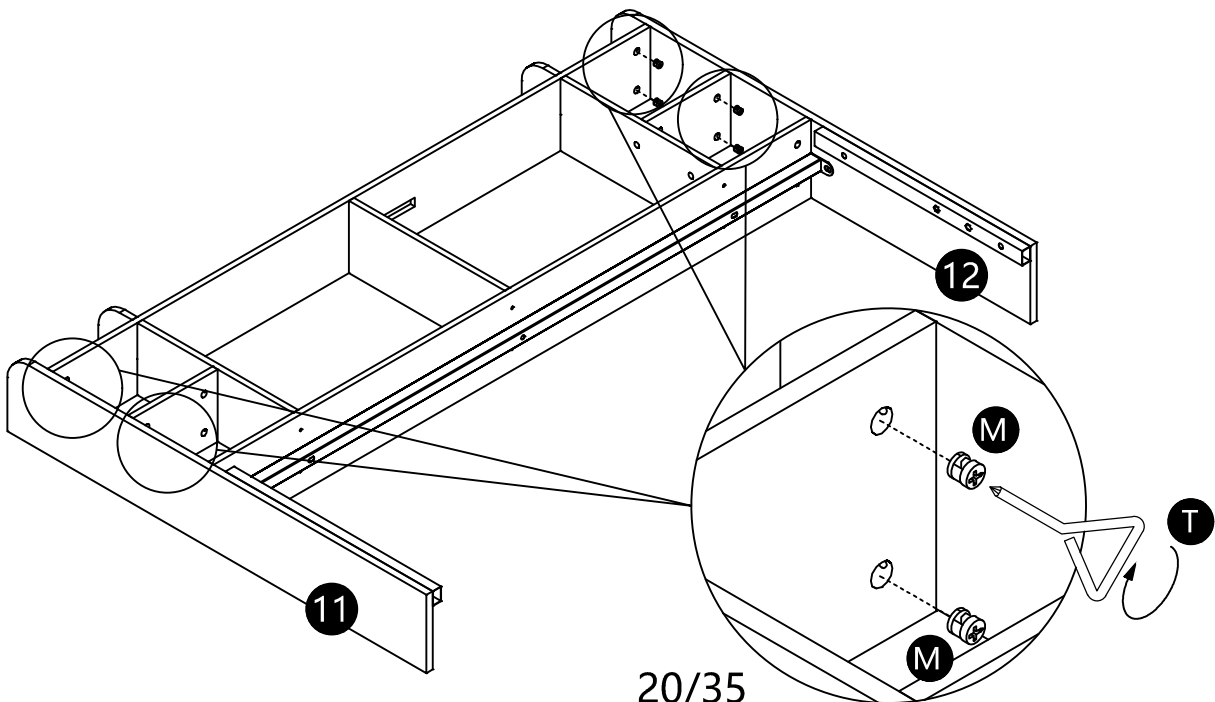
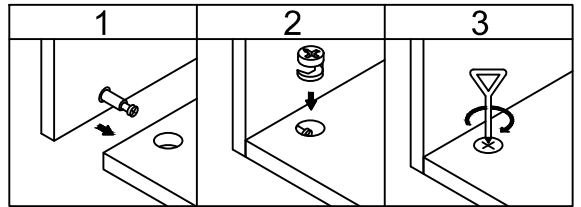

19

M8X12
AX4pcs

M8
SX1pc

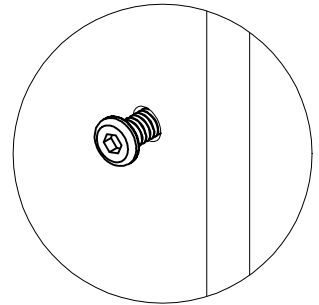
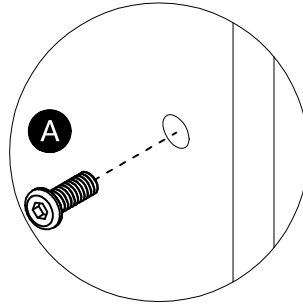
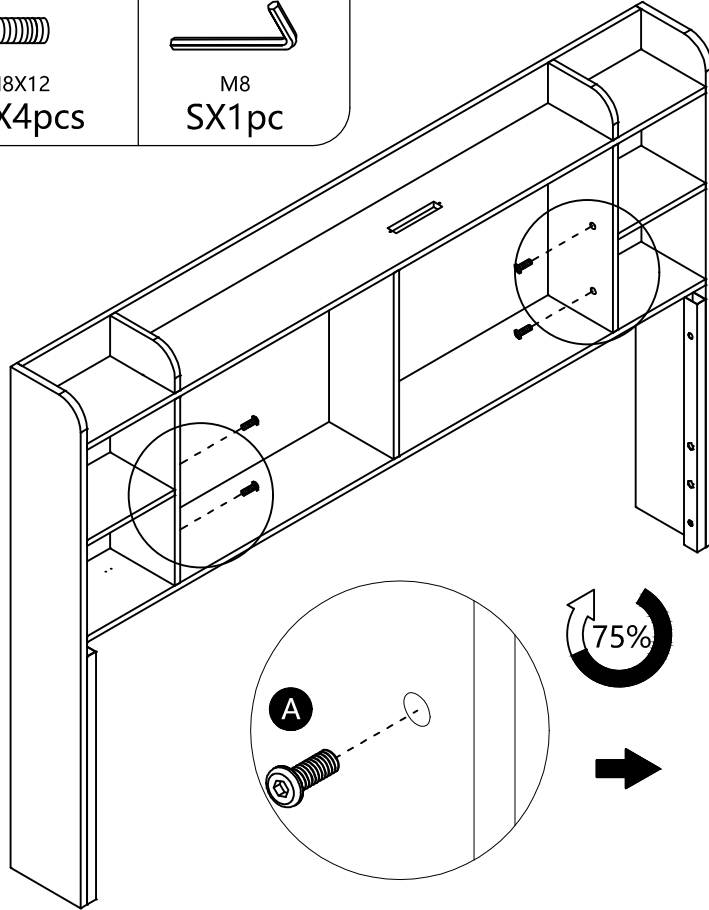

20

M8X13
BX4pcs

M8
SX1pc

NO.1

NO.1

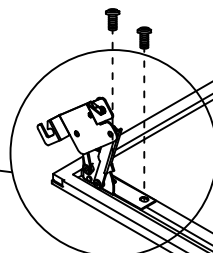
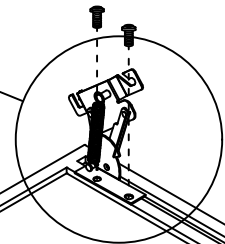
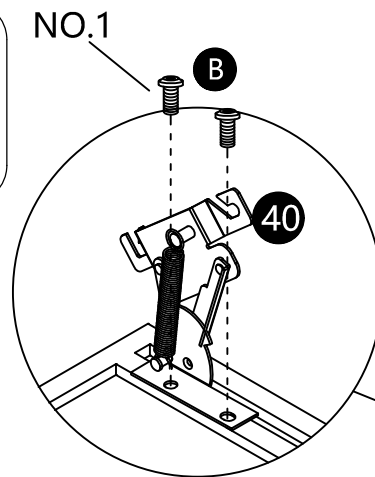
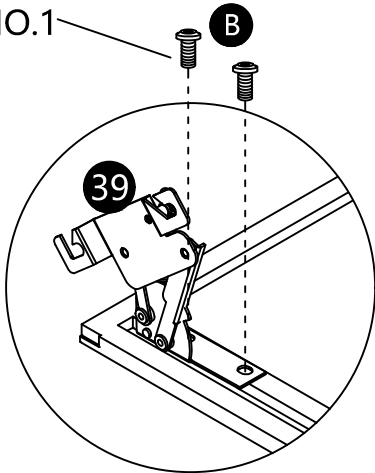

1

21

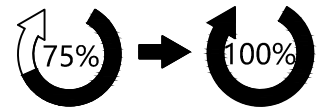
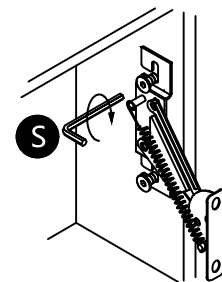
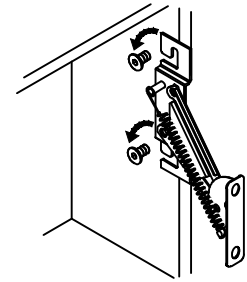
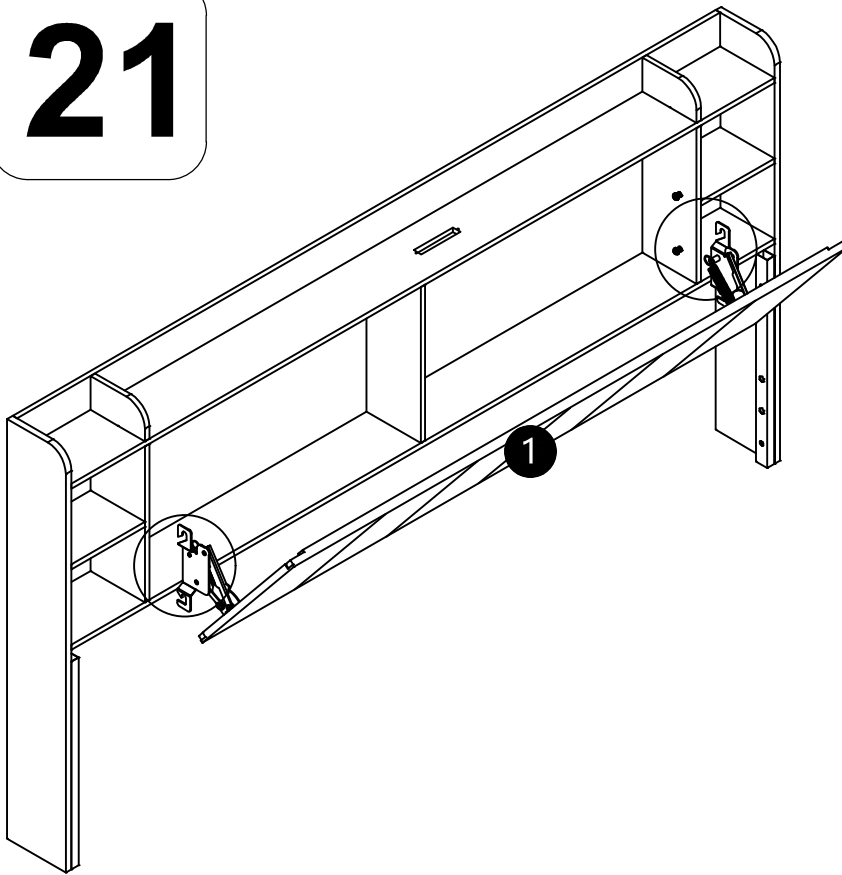

22



M8X35
DX2pcs



M8
SX1pc

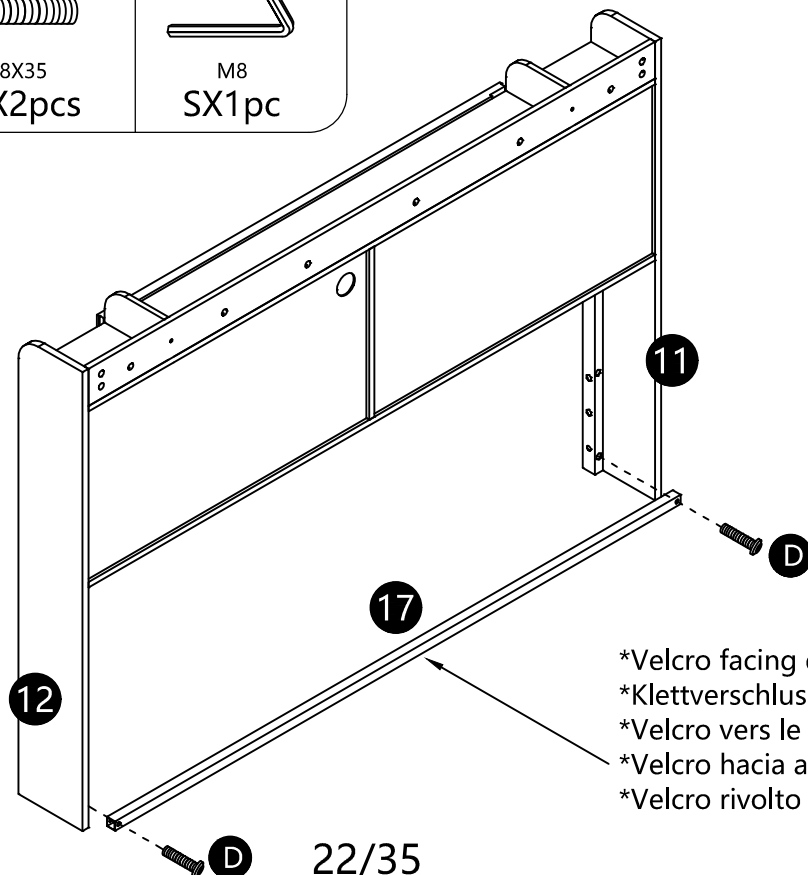

- *Velcro facing downwards
- *Klettverschluss nach unten
- *Velcro vers le bas
- *Velcro hacia abajo
- *Velcro rivolto verso il basso

22/35

23

M8X13
BX4pcs

M8
SX1pc

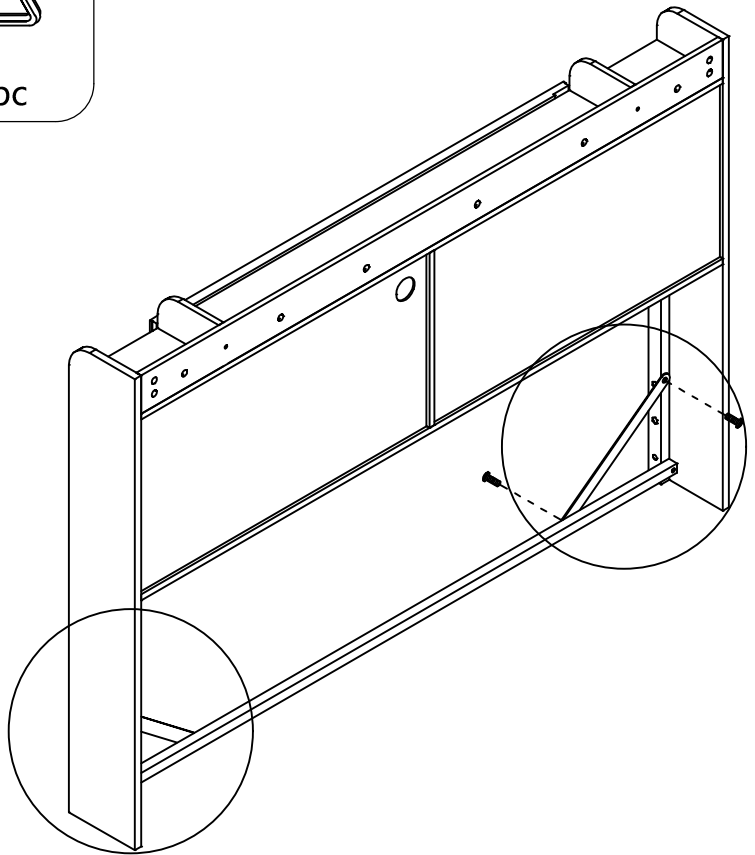
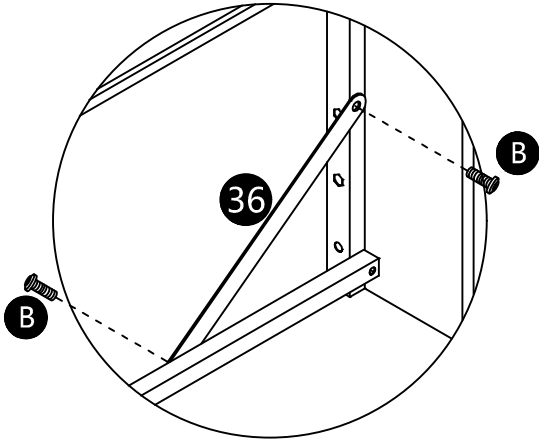

24

M6X18
FX16pcs

M6
RX1pc

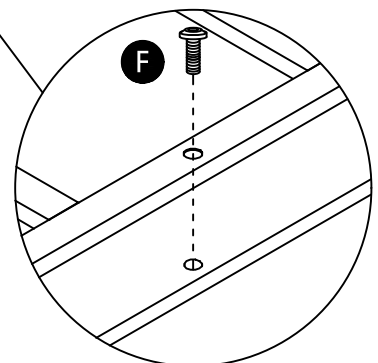
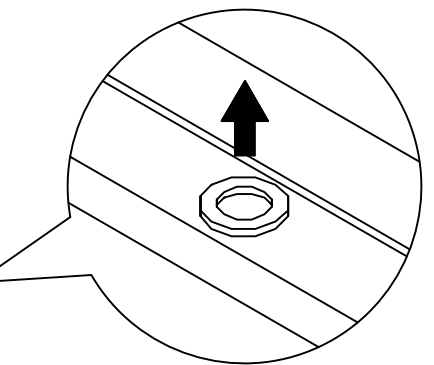
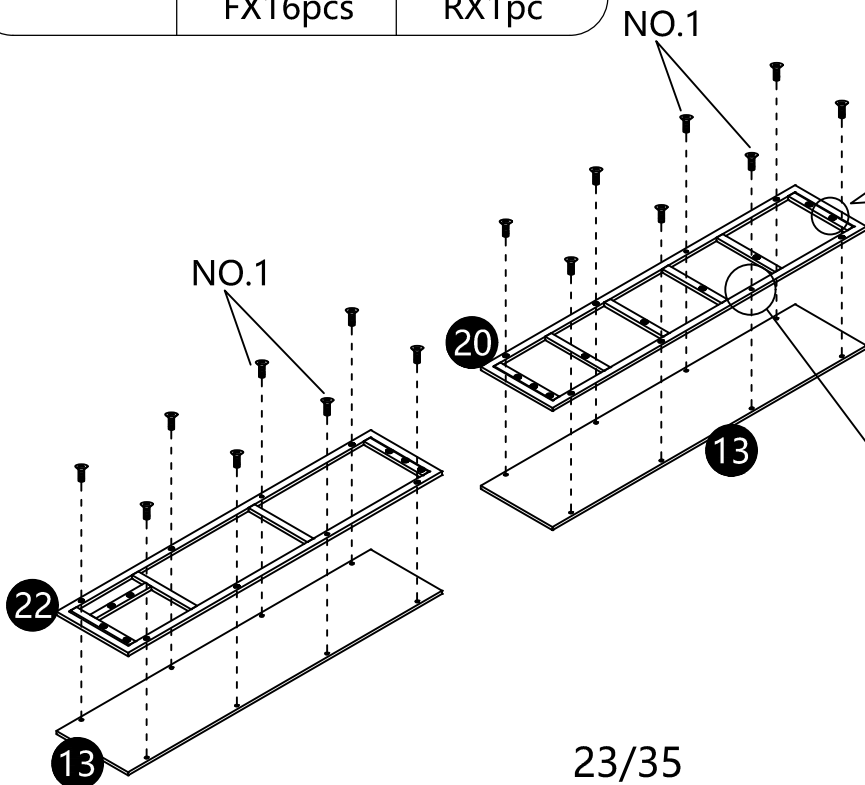

25

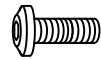

M6X18
FX16pcs



M6
RX1pc

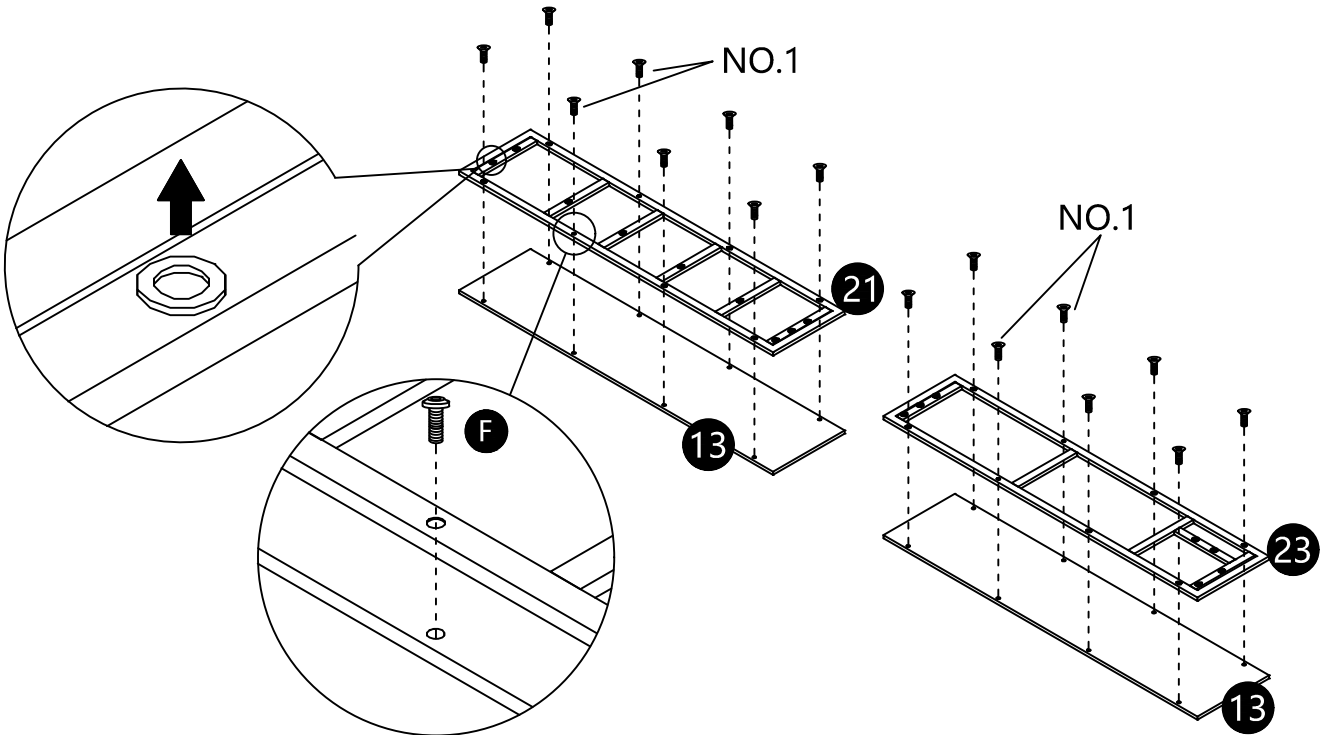

26

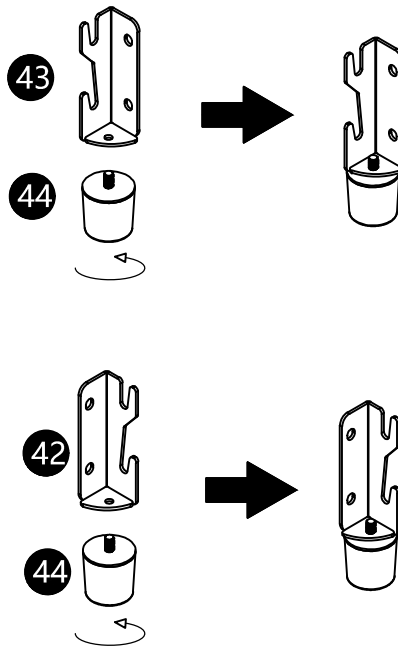

27

M8X13
BX8pcs

M8
SX1pc

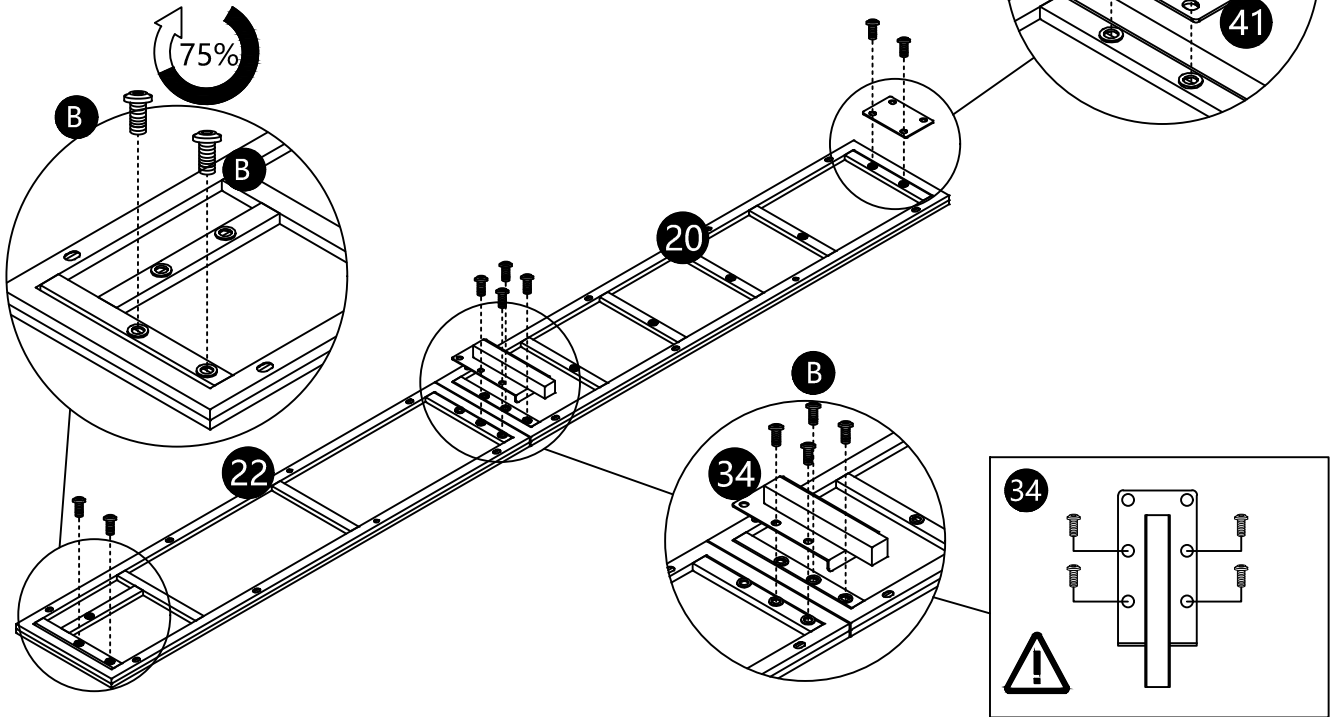

28

M8X13
BX8pcs

M8
SX1pc

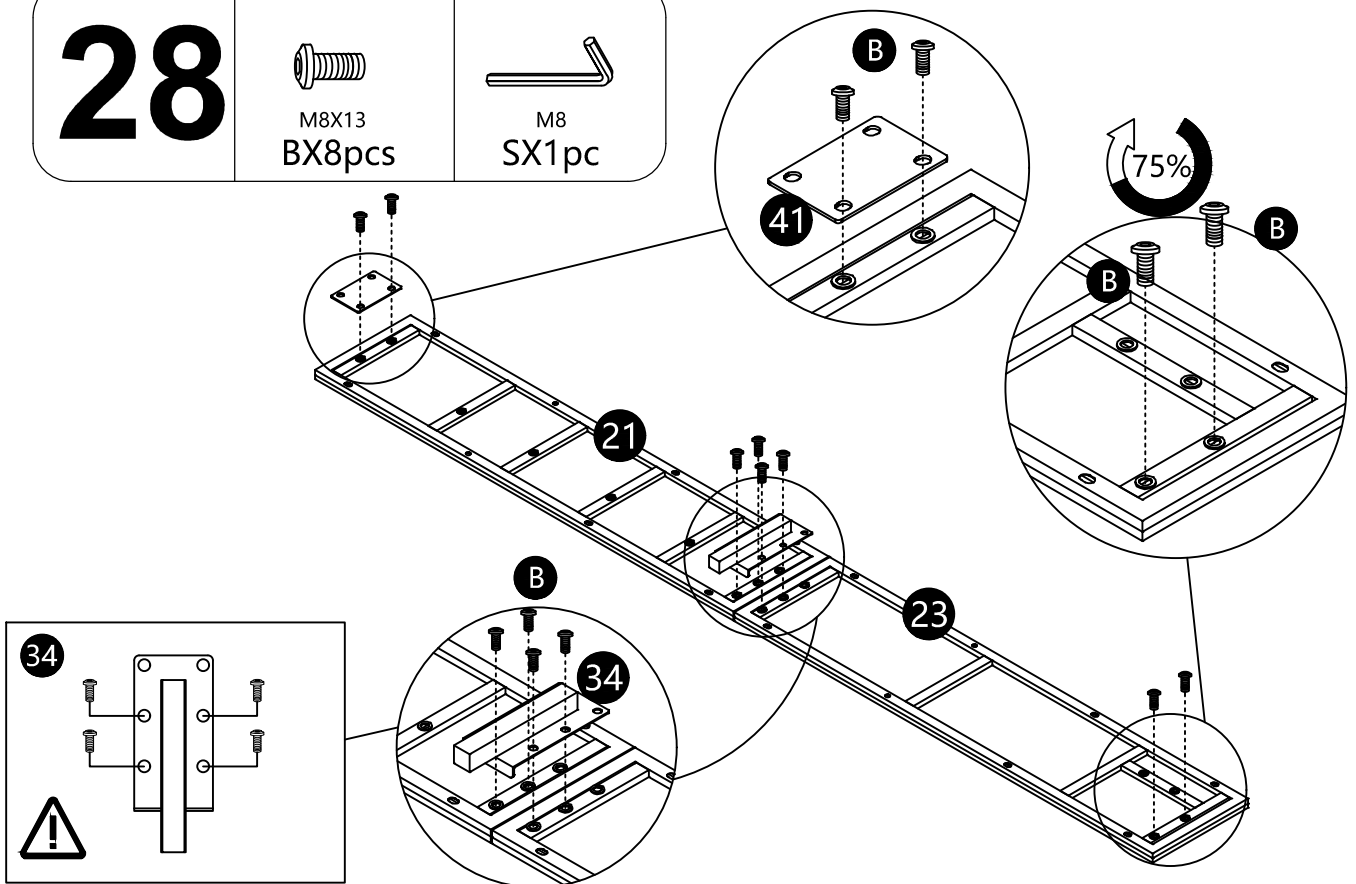

29

M8X13
BX8pcs

M8
SX1pc

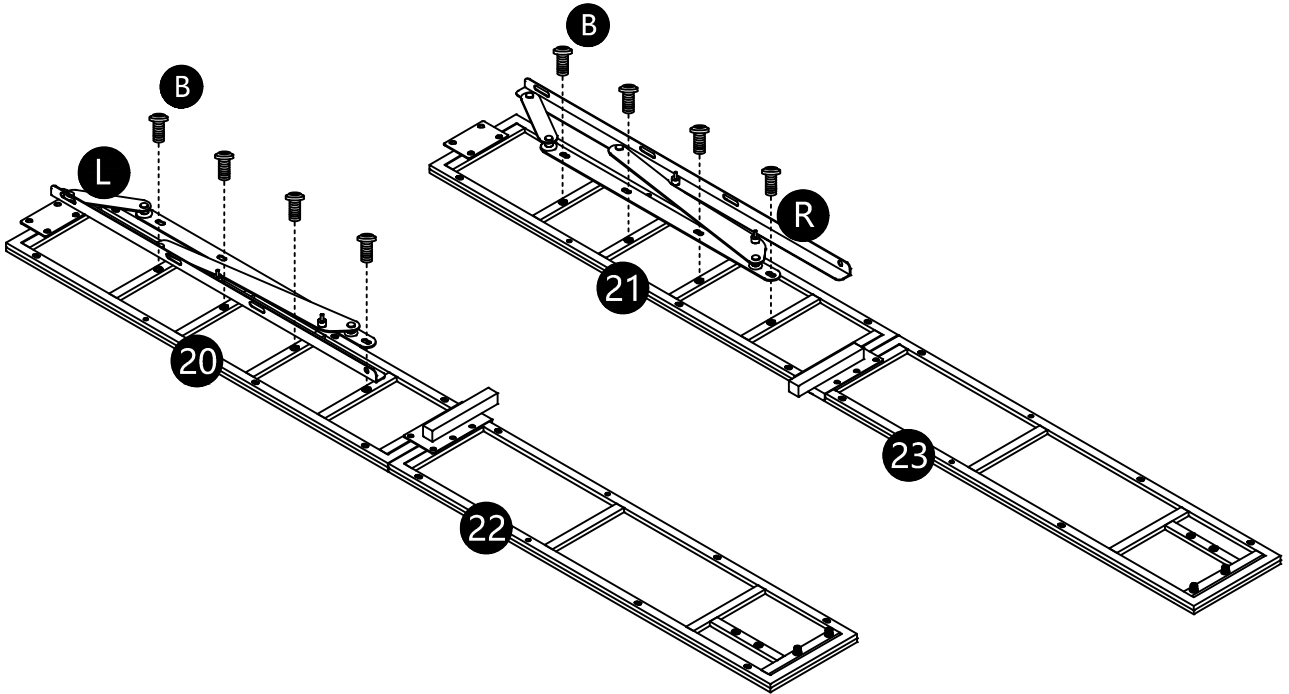

30

M8X13
BX4pcs

M8
SX1pc

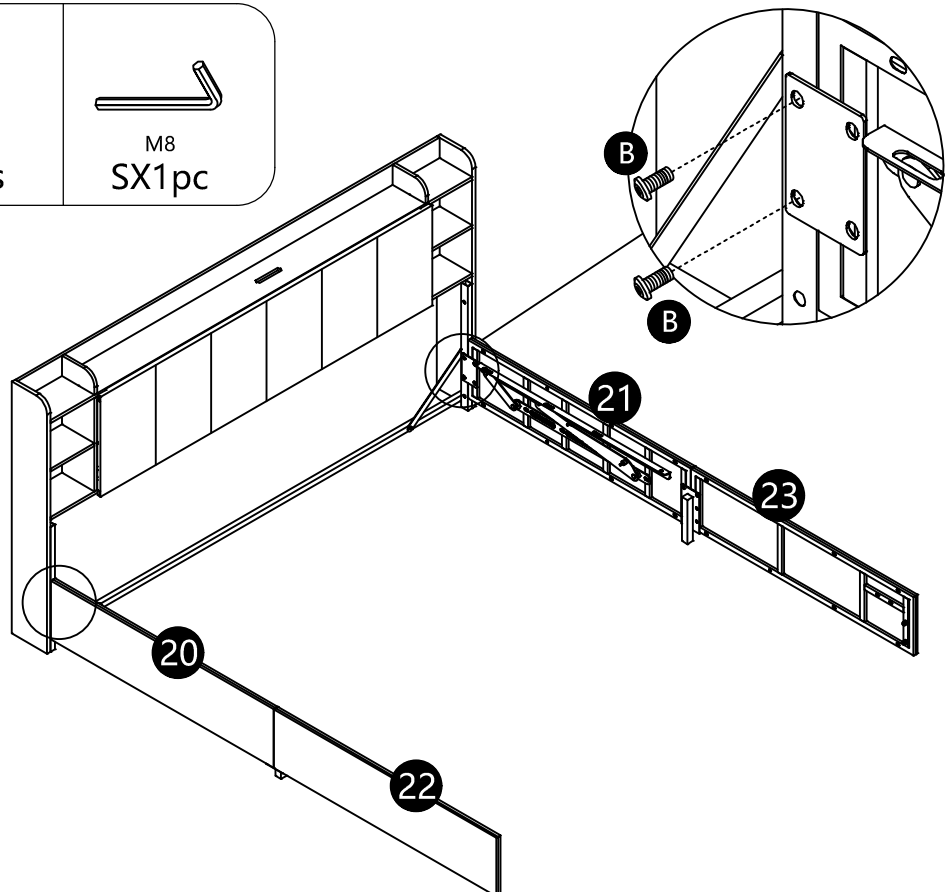

31

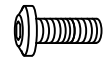

M6X18
FX10pcs



M6
RX1pc

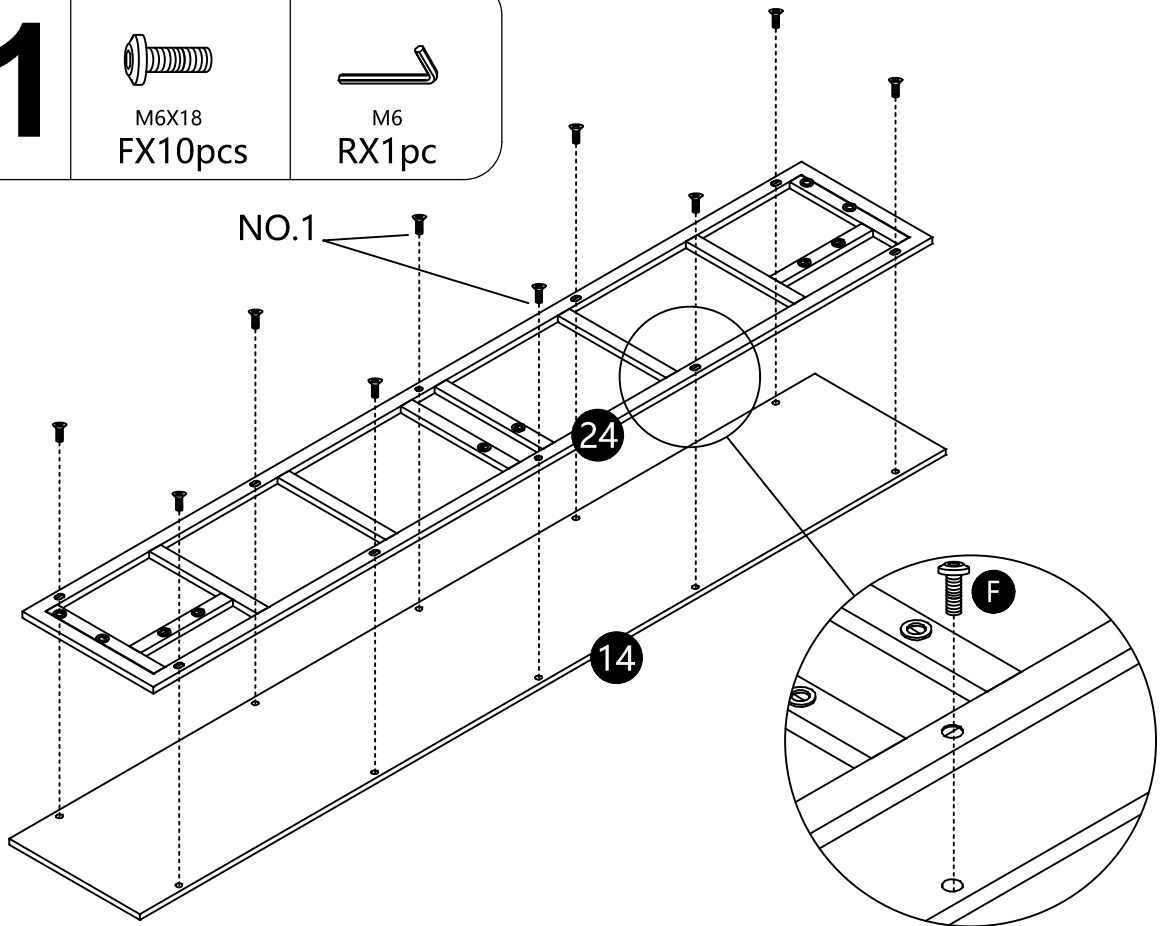

32



M8X13
BX4pcs

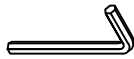

M8
SX1pc

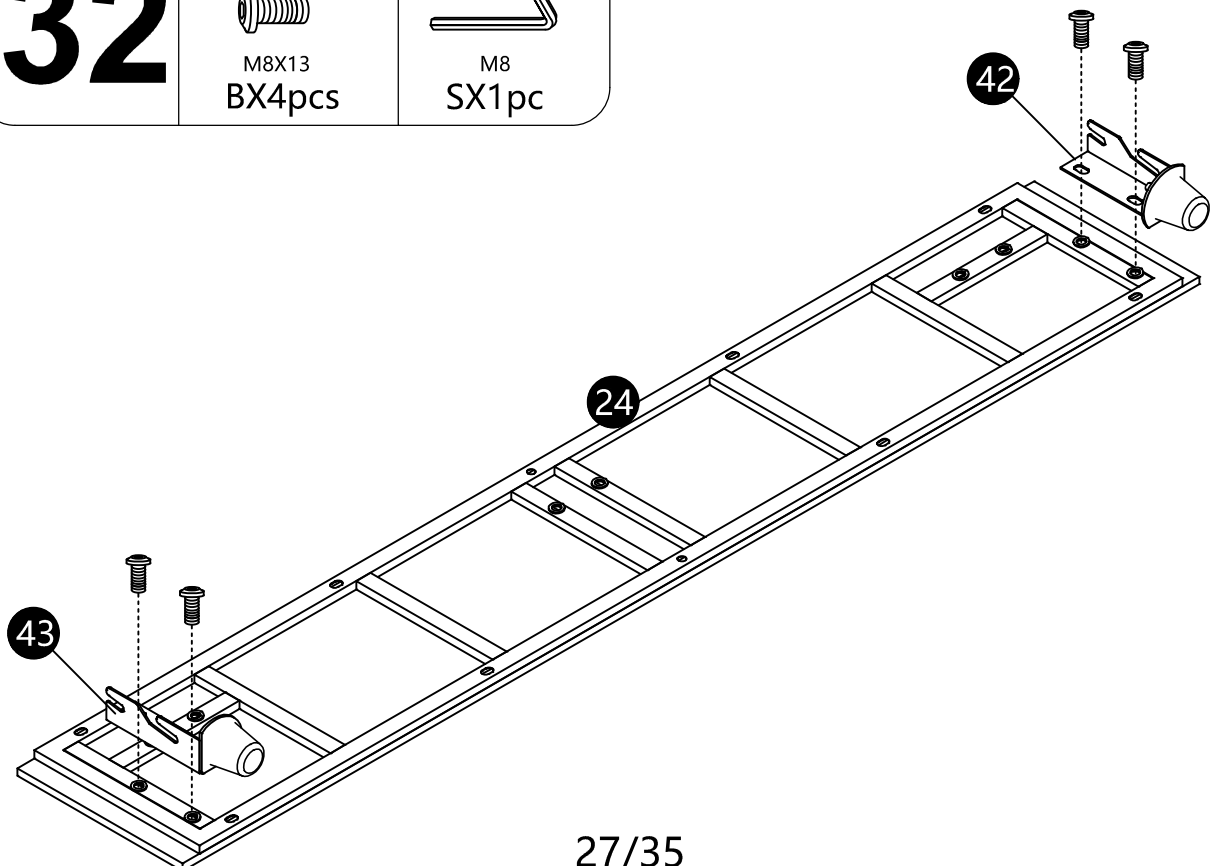

33

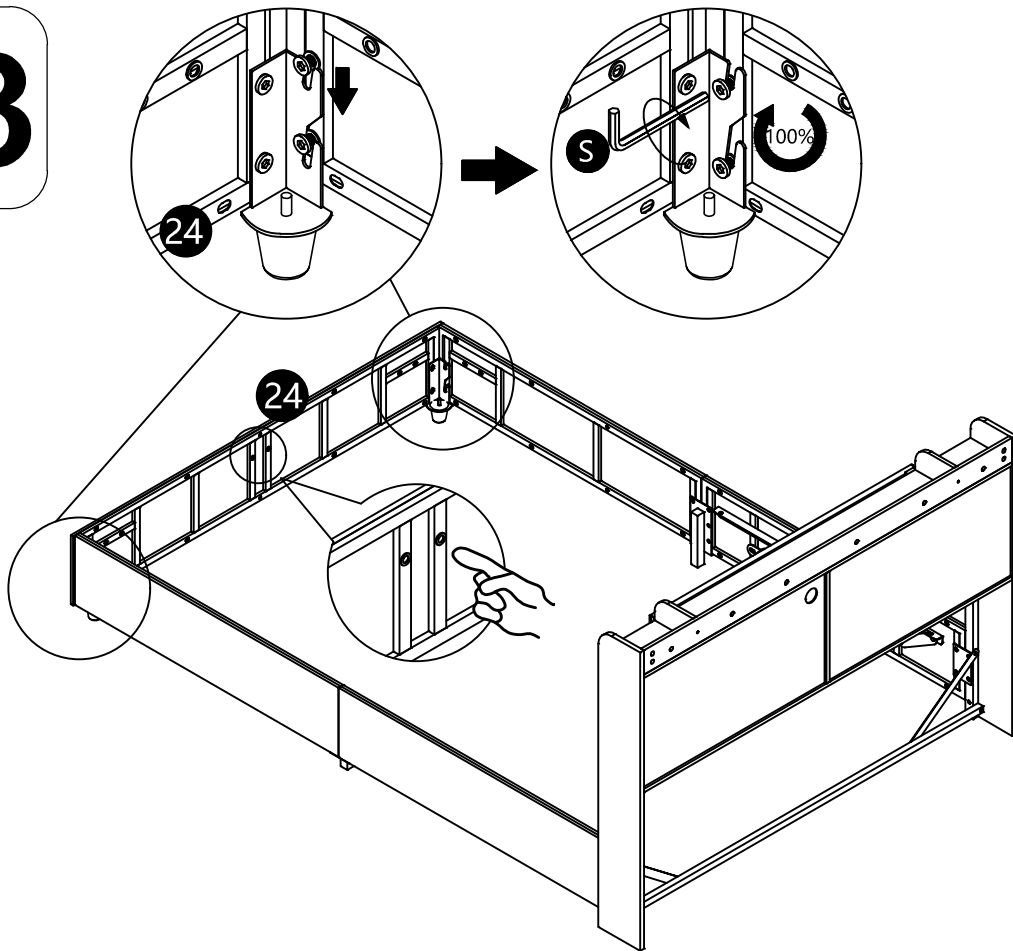

34



M8X13
BX4pcs



M8
SX1pc

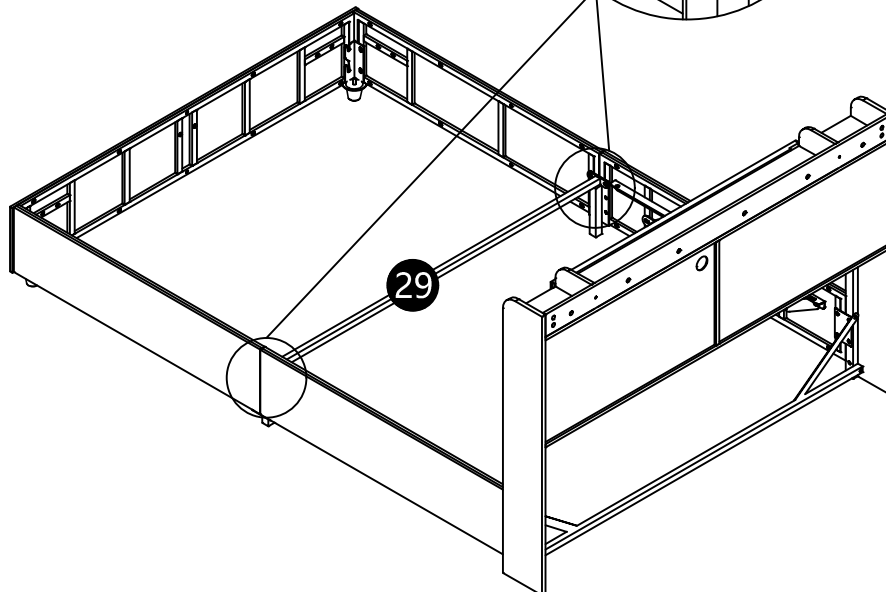
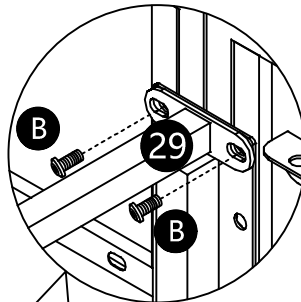

35



M8X13
BX8pcs



M8X35
DX2pcs



M8
SX1pc



WX4pcs

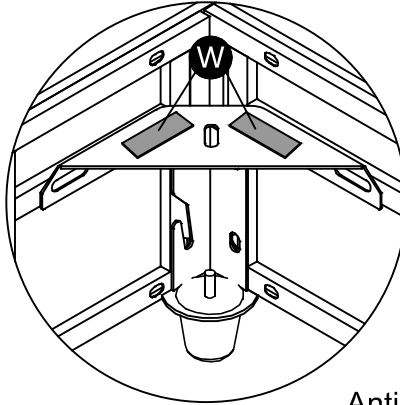
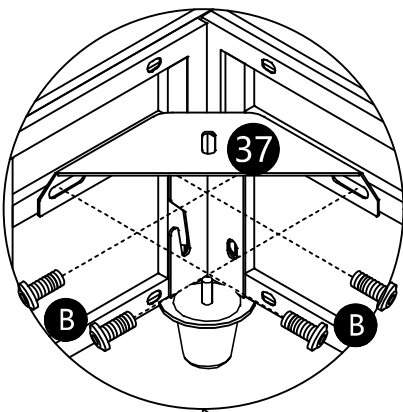

Anti stick
paper

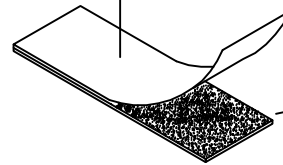

silent sticker

Silent sticker

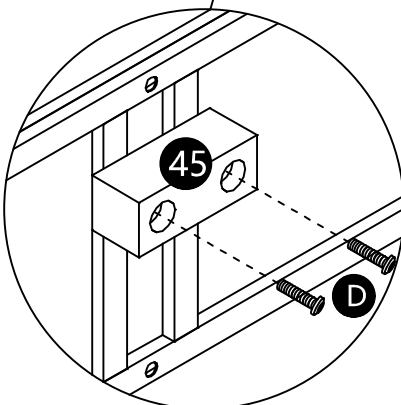
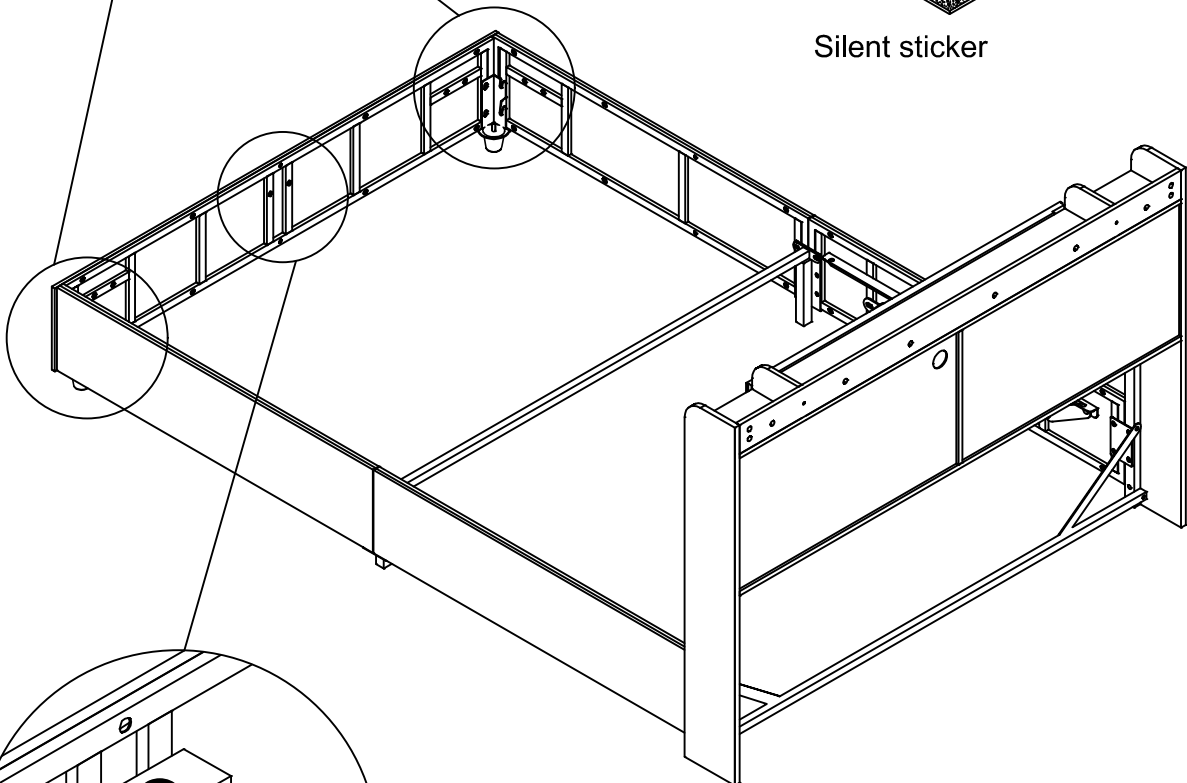

36

M3*16
KX8pcs

PX8pcs

TX1pc

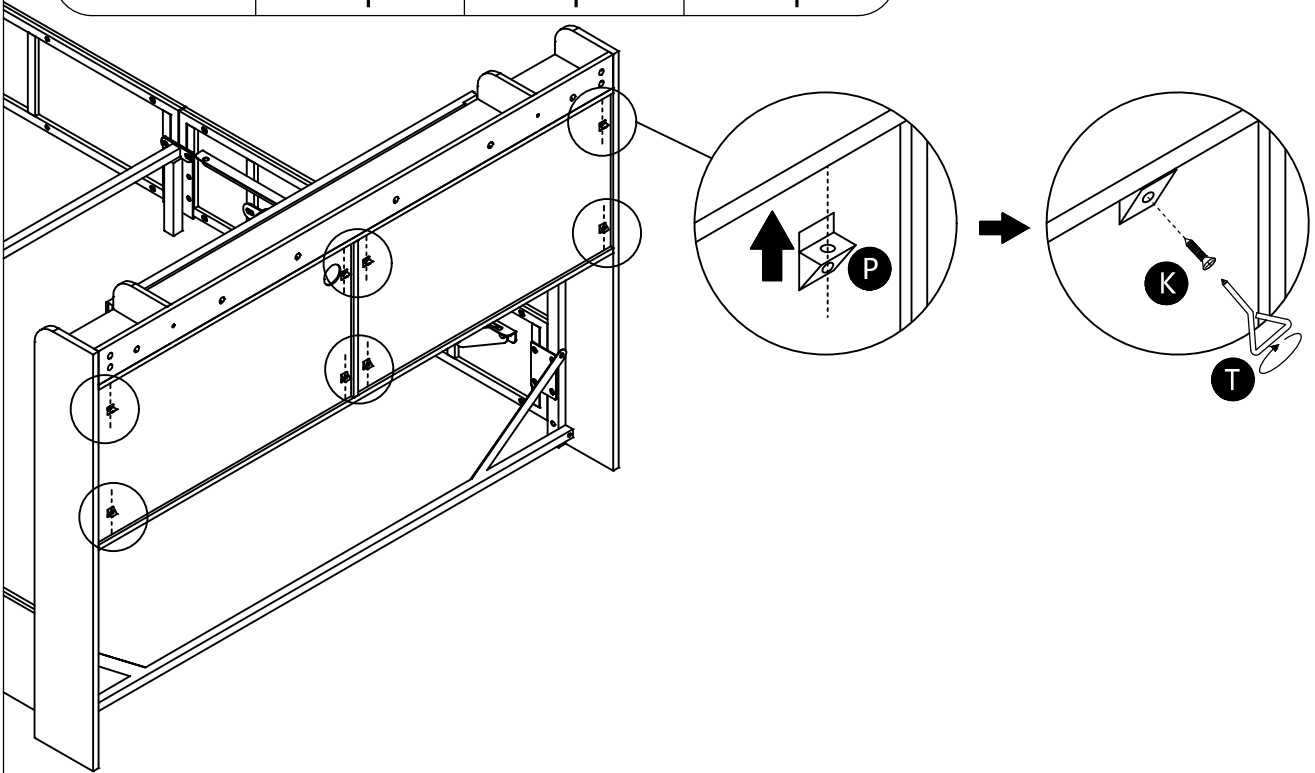

37

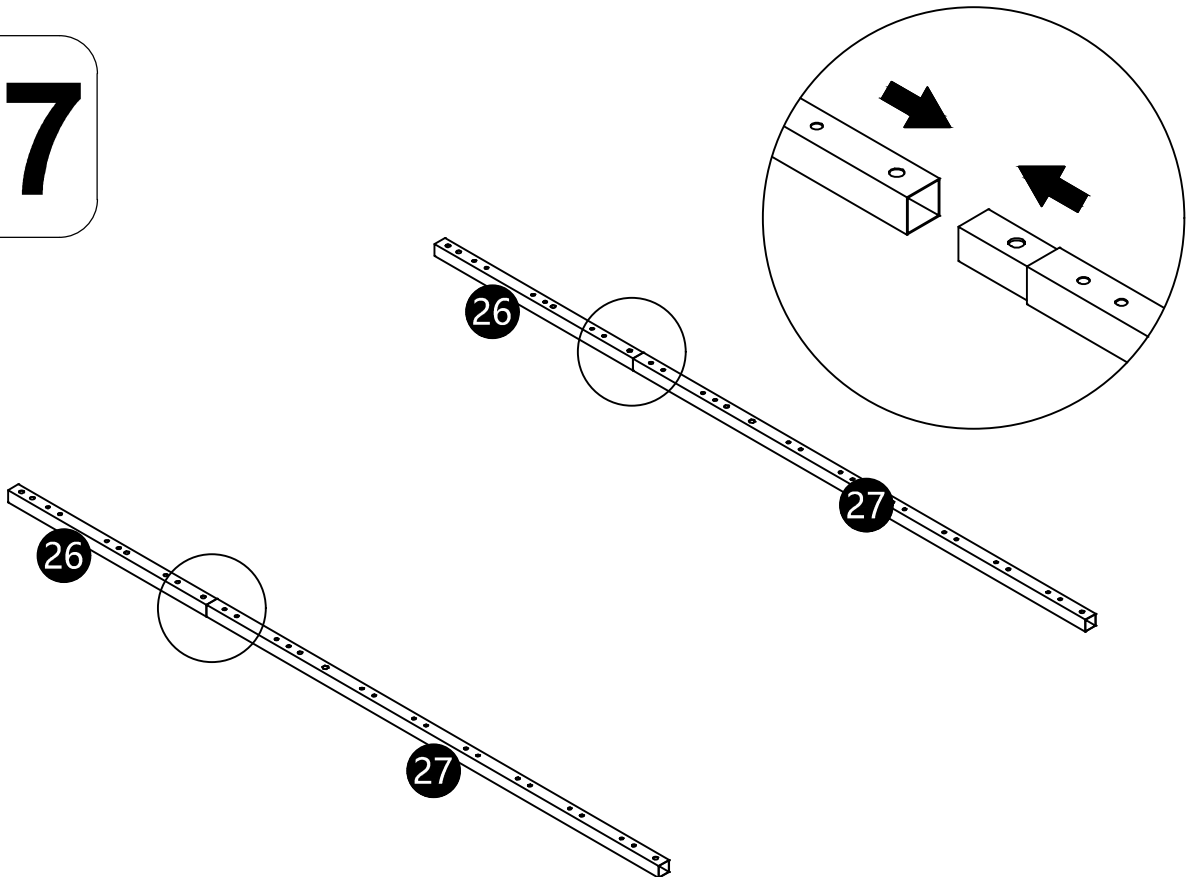

38



M8X12
AX8pcs



M8
SX1pc

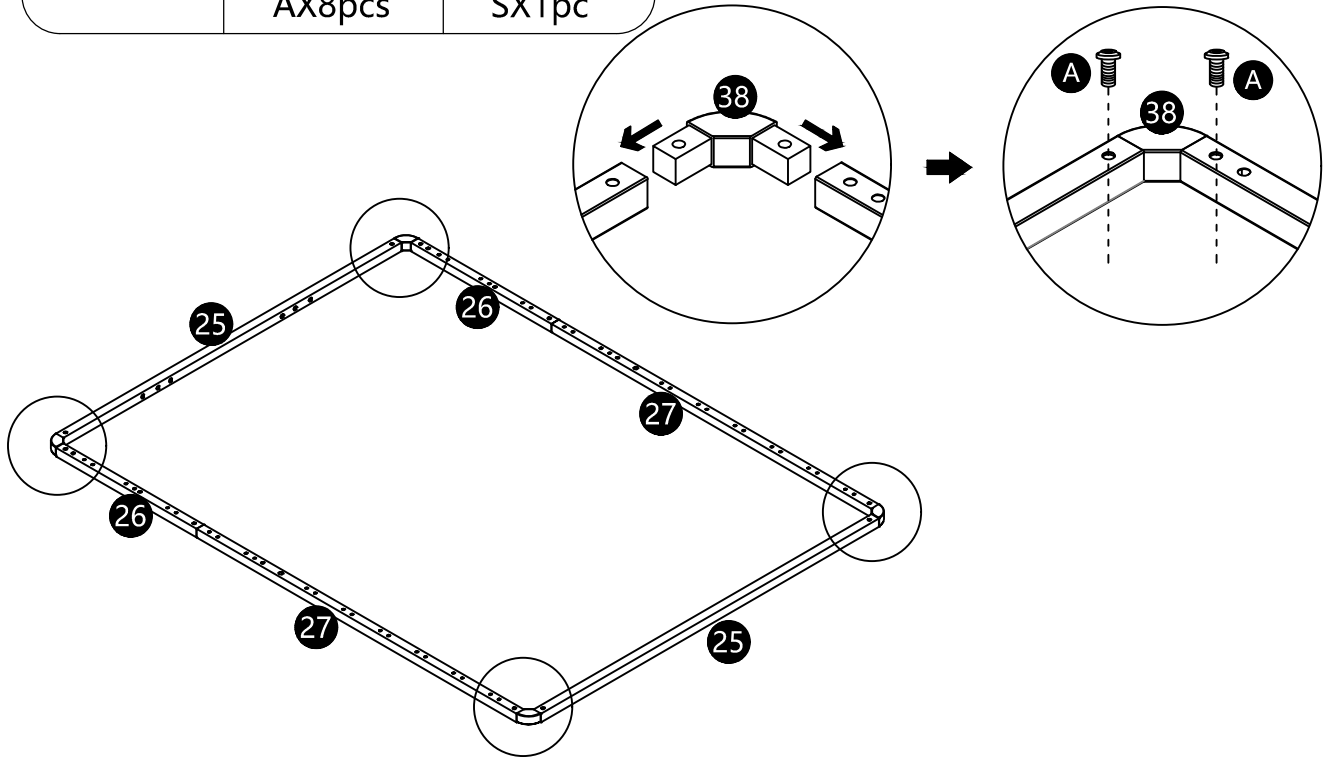

39



M8X13
BX2pcs



M8
SX1pc

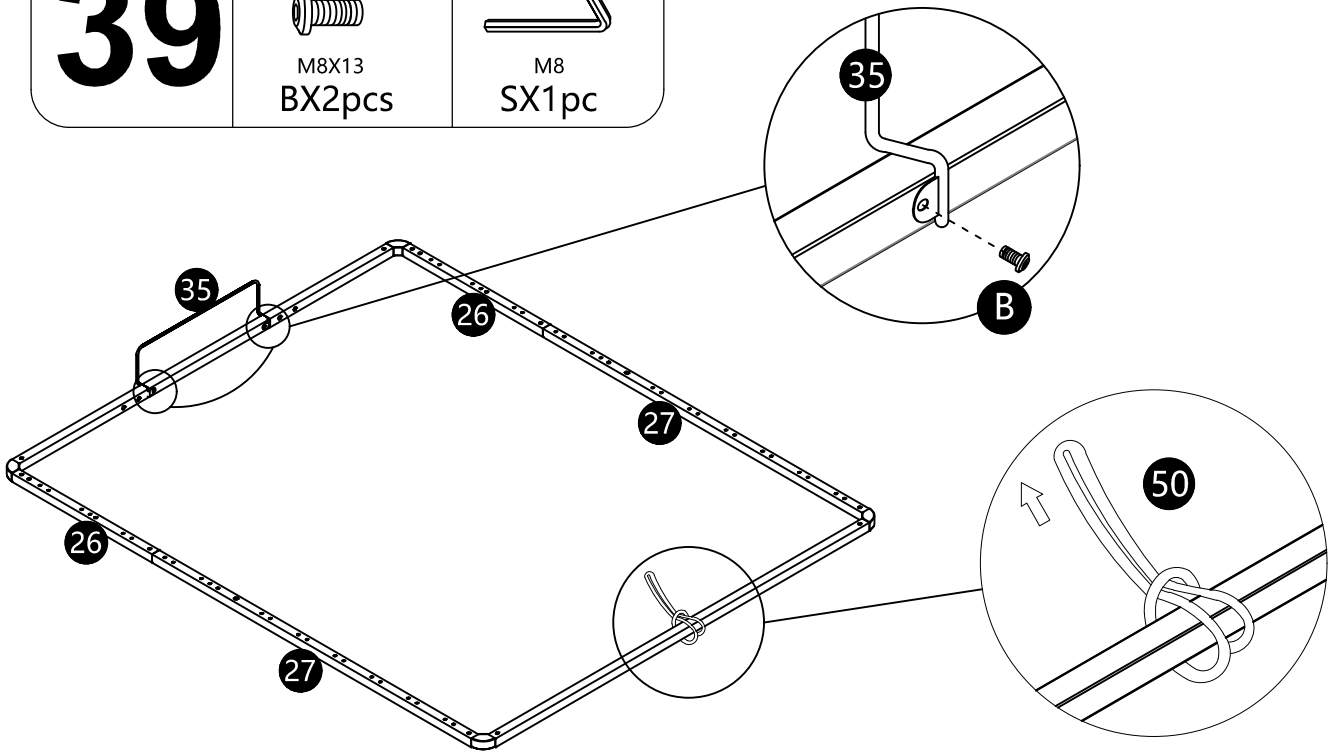

40



M8X45
EX2pcs



M8
SX1pc



M8
OX2pcs



UX1pc

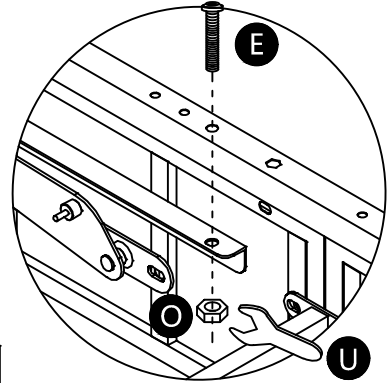
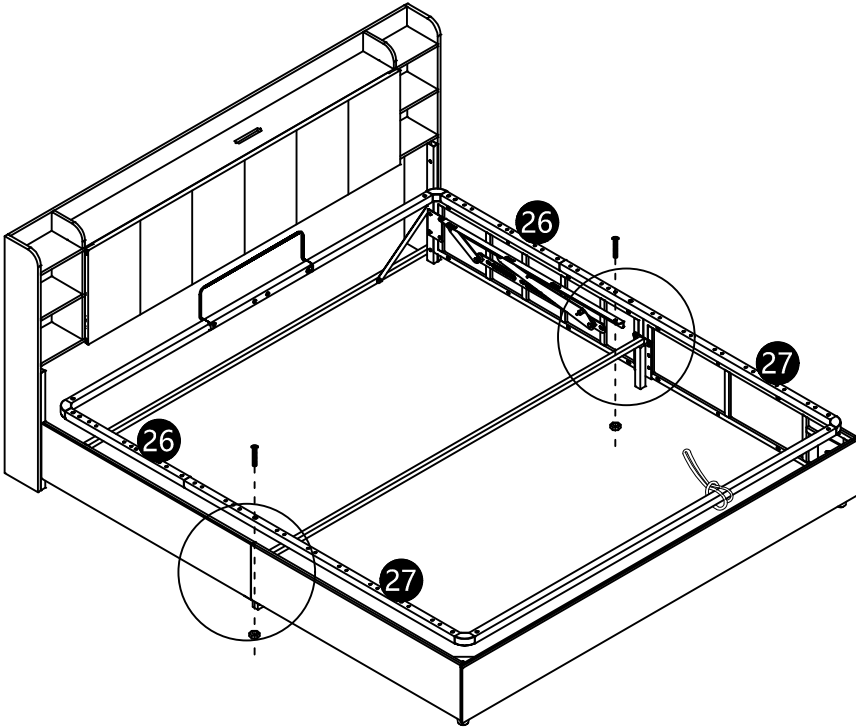

41



M8X45
EX6pcs



M8
SX1pc



M8
OX6pcs



UX1pc

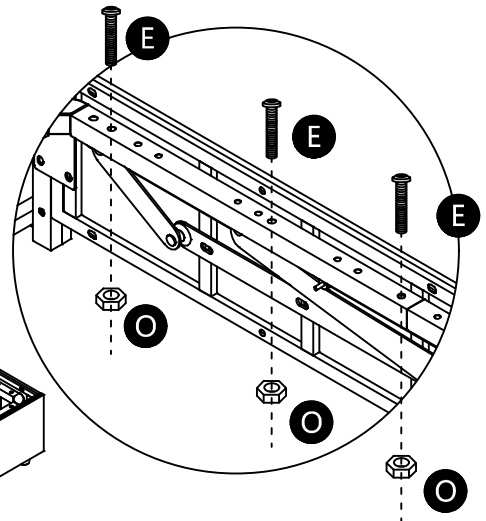
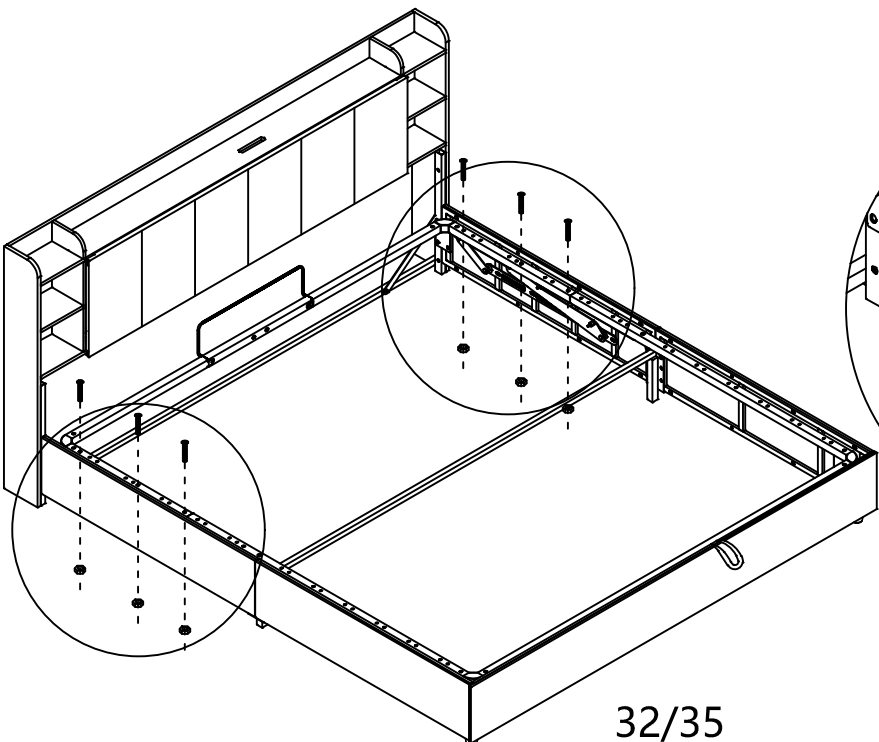

42

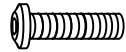

M8X35
DX8pcs



M8*Ø22
NX8pcs



M8
SX1pc

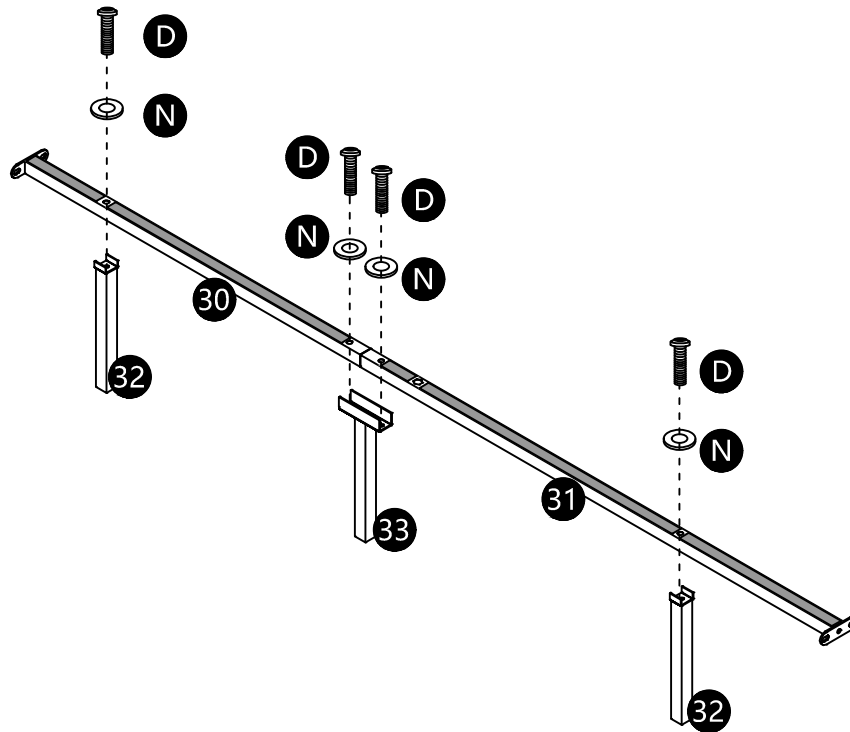

X2

43



M8X13
BX8pcs



M8
SX1pc

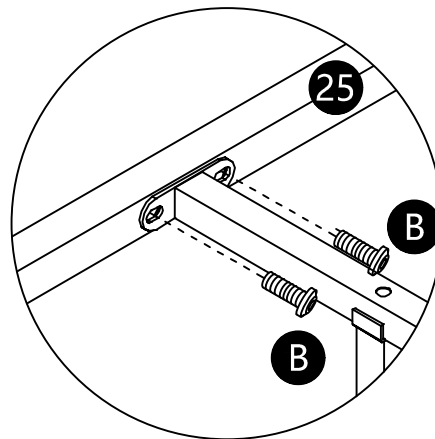
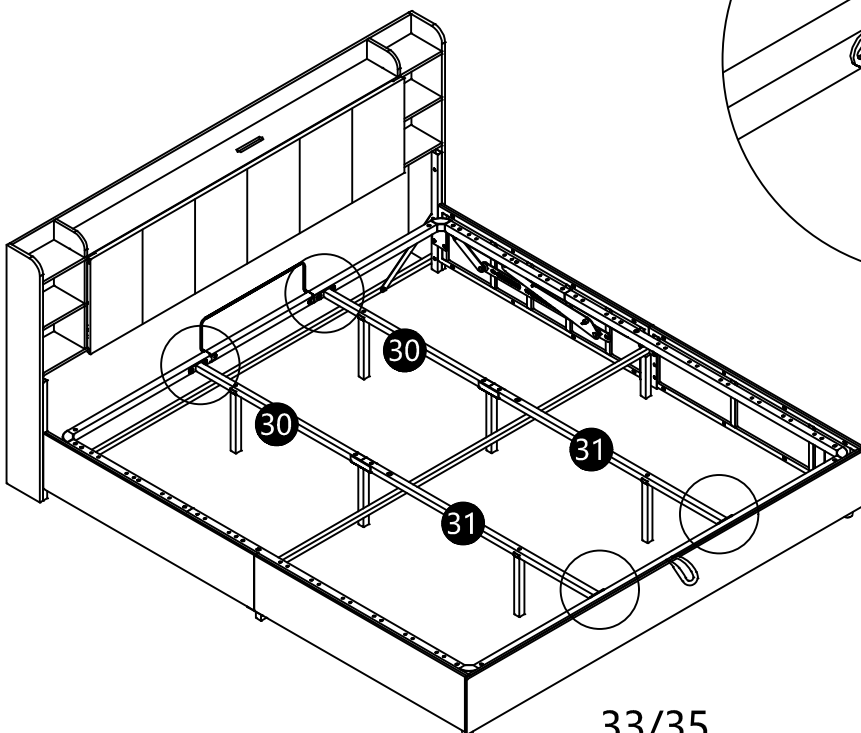

44

M8*25
CX2pcs

M8*35
DX2pcs

M8*Ø22
NX2pcs

M8
SX1pc

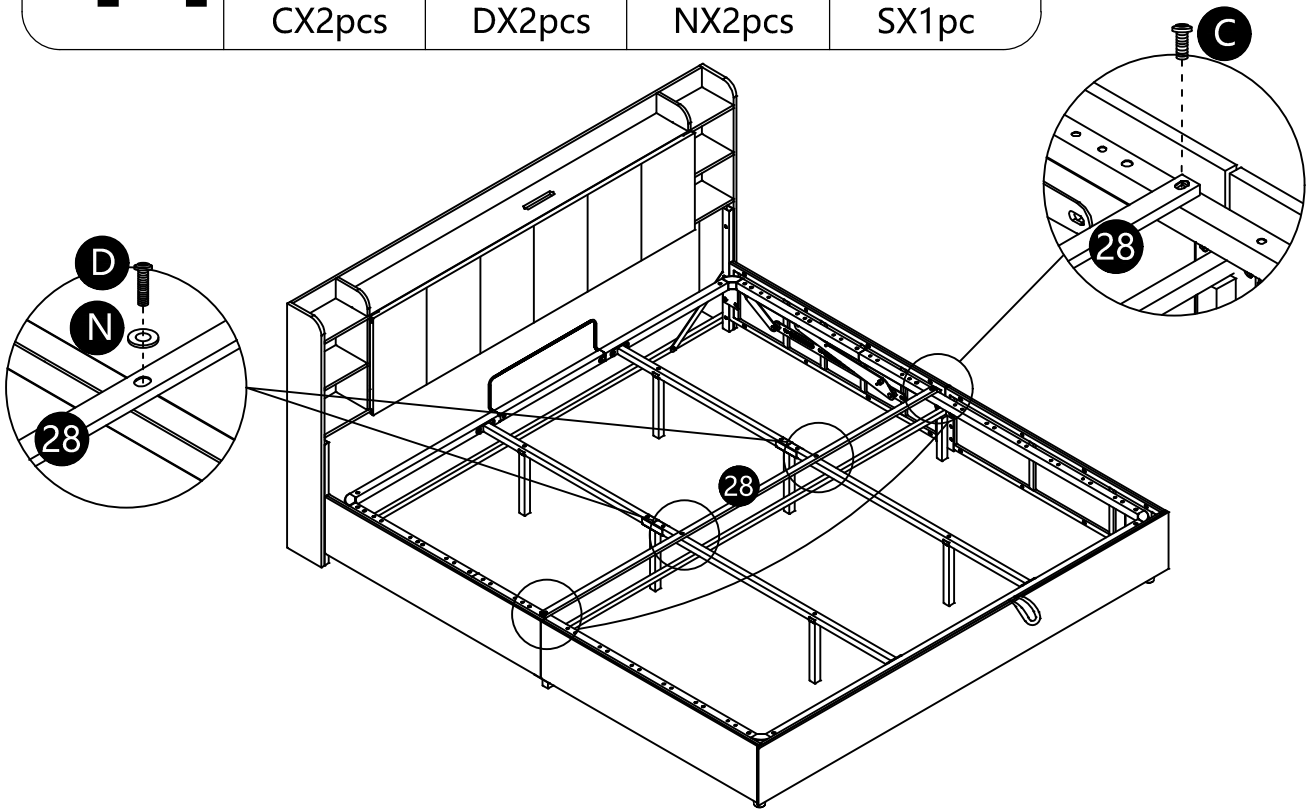

45

M8
OX4pcs

UX1pc

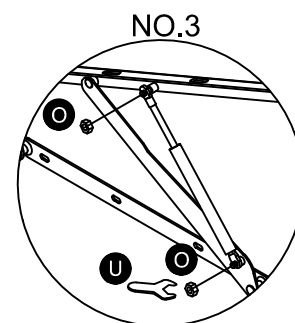
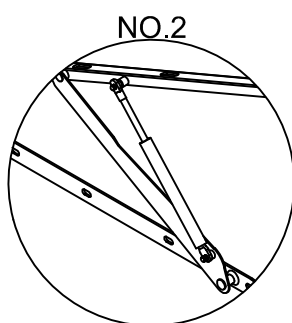
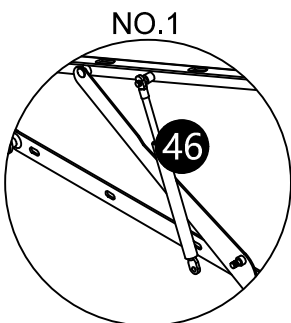
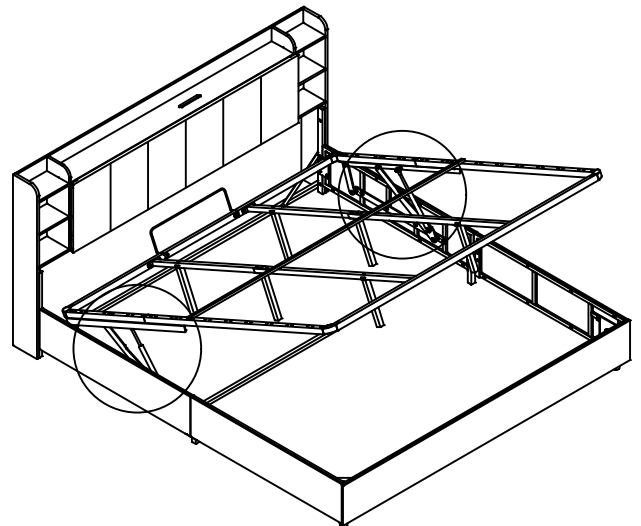

46

M3*12
JX2pcs

TX1pc

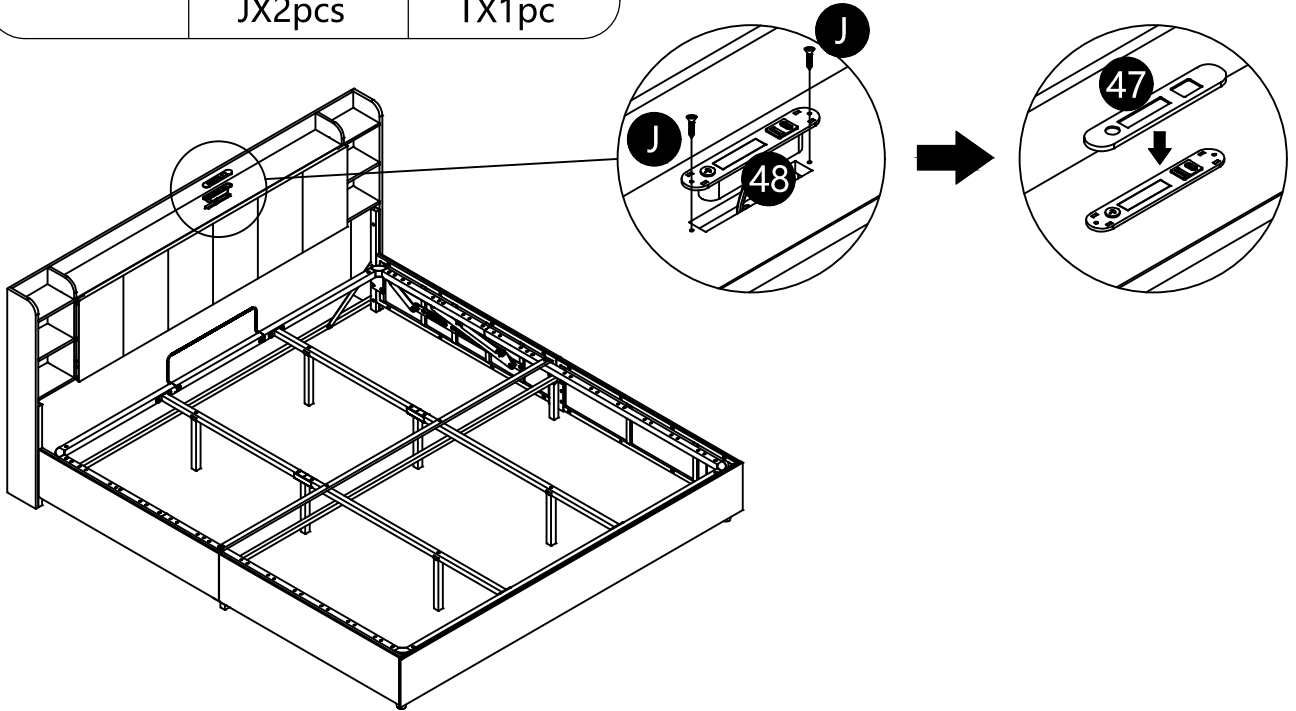

47

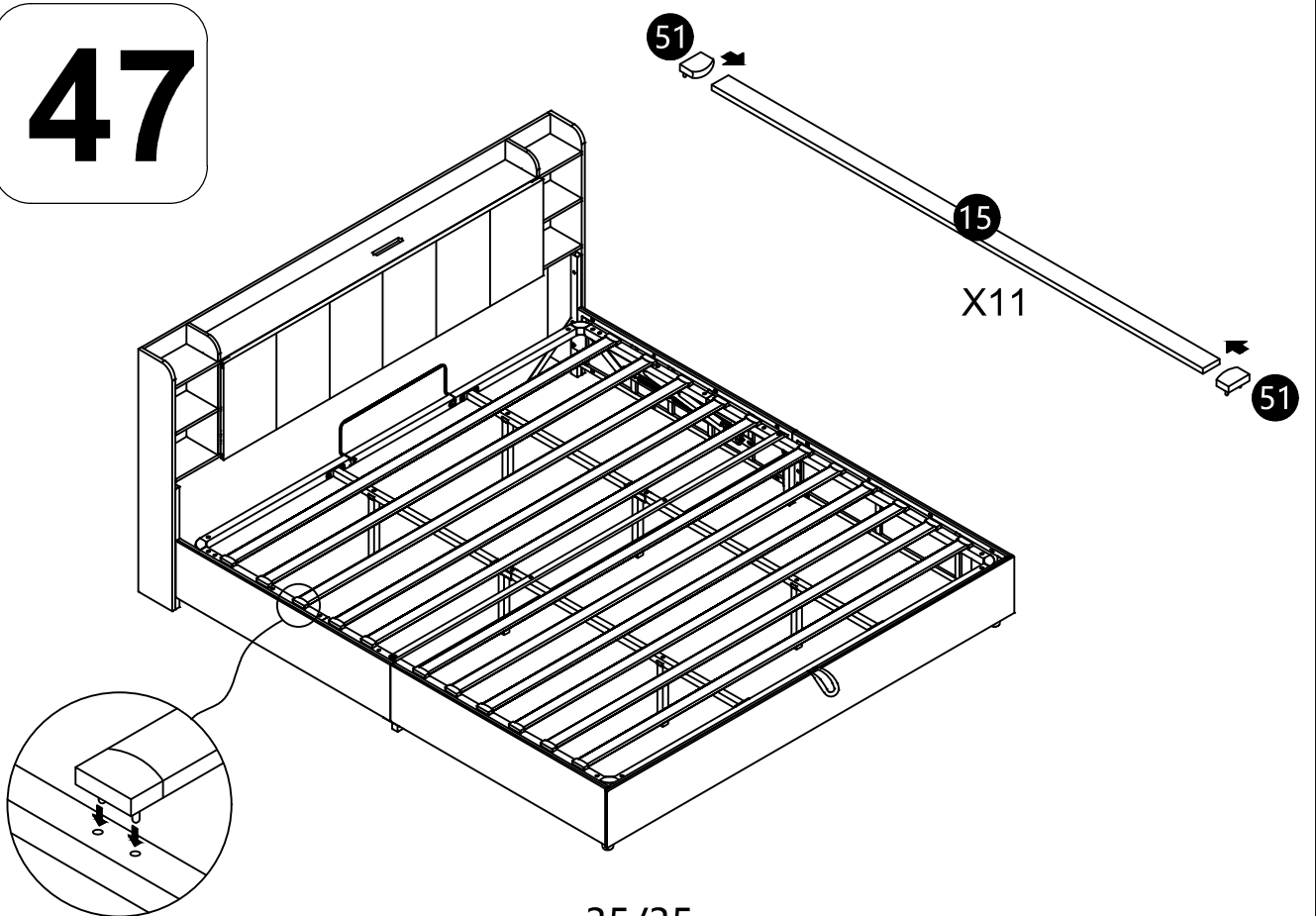



KeySense Testing & Certification International Co., Ltd.
1-3F, Lab Building, No.29 District, Zhongkai Hi-Tech
Industrial Development Park, Huizhou, Guangdong,
China

Tel:0752-3219929
Fax:0752-3219929
<http://www.kst-cert.com>

Technical Compliance Statement

Certificate No.: KST250425A003Q01

Report No.: KST250425E003Q01

The following products have been tested by us with the listed standards and found in compliance with the council UK EMC Regulations (SI 2016/1091) .
It is demonstrative for the compliance with this EMC Directive.

Holder: Dong Guan City Luckking Electronics Co.,Ltd

Address: Building 1, No.3, Qinghutou Innovation Road Tangxia Town, Dongguan City, Guangdong

Product: Bedside USB night light

Model Name: LKS081

Trade Name: LUCKKING

Test Standard	
■ EMC	BS EN IEC 55015:2019+A11:2020 BS EN IEC 61547:2023

**UK
CA**

Signature: 
Name: Jack.L
Position: Supervisor
Date: May 06, 2025

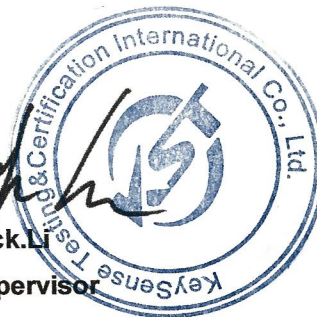

The statement is based on single evaluation of one sample of above mentioned product. It does not imply an assessment of the whole production and does not permit the use of the test lab. Logo.



KeySense Testing & Certification International Co., Ltd.
 1-3F, Lab Building, No.29 District, Zhongkai Hi-Tech
 Industrial Development Park, Huizhou, Guangdong,
 China

Tel:0752-3219929
 Fax:0752-3219929
<http://www.kst-cert.com>

Technical Compliance Statement

Certificate No.: KST250425E003Q01

Report No.: KST250425E003Q01

The following product has been tested by us with the listed standards and found in Compliance with the council EMC directive 2014/30/EU. It is demonstrative for the Compliance with this EMC Directive.

Holder: Dong Guan City Luckking Electronics Co., Ltd

Address: Building 1, No.3, Qinghutou Innovation Road Tangxia Town, Dongguan City, Guangdong

Product: Bedside USB night light

Model Name: LKS081

Trade Name: LUCKKING

Test Standard	
EN IEC 55015:2019+A11:2020	Limits and methods of measurement of radio disturbance characteristics of electrical lighting and similar equipment
EN IEC 61547:2023	Equipment for general lighting purposes - EMC immunity requirements



Signature: 

Name: Jack.Li

Position: Supervisor

Date: May 06, 2025



The statement is based on single evaluation of one sample of above mentioned product. It does not imply an assessment of the whole production and does not permit the use of the test lab. Logo.



KeySense Testing & Certification International Co., Ltd.
1-3F, Lab Building, No.29 District, Zhongkai Hi-Tech
Industrial Development Park, Huizhou, Guangdong,
China

Tel:0752-3219929
Fax:0752-3219929
<http://www.kst-cert.com>

Declaration of conformity

Certificate No.: KST250425F003Q01

Report No.: KST250425F003Q01

Holder: Dong Guan City Luckking Electronics Co.,Ltd

Address: Building 1, No.3, Qinghutou Innovation Road Tangxia Town, Dongguan
City, Guangdong

Product: Bedside USB night light

Model Name: LKS081

Trade Name: LUCKKING

We, KeySense Testing & Certification International Co., Ltd., hereby certify that:

The device bearing the name and model specified above has been shown to comply with applicable technical standards as indicated in the test report and has been tested in accordance with the test specified procedures.

Standards:

FCC CFR Title 47 Part 15 Subpart B

ANSI C63.4-2014

Signature: 

Name:

Jack.Li

Position:

Supervisor

Date:

May 06, 2025



The statement is based on single evaluation of one sample of above mentioned product. It does not imply an assessment of the whole production and does not permit the use of the test lab. Logo.



Importeur	Decobus Handel GmbH		
Adresse	Innungsstraße 9, 21244 Buchholz, Deutschland		
Email/URL	https://www.decobusgroup.de		
Hersteller	Guangdong Zhangong Eledtrical Technology Co. LTD		
Adresse	701, Building 29, hifu Garden, Xingtan Town, ShundeDistrict, Foshan City, Guangdong Province		
Email/URL	zkt@zkt-lab.com		
Produkt:Mountable USB Hub/USB CHARGER Model:ZG-USB-12			
Input: 100-240V Output: 5V 2A, 9v 2.22A, 12V 1.67A			
Partienumm	202510		
Hergestellt in	China		
<table border="1"><tr><td>EC</td><td>REP</td></tr></table>	EC	REP	Decobus Handel GmbH Innungsstraße 9, 21244 Buchholz, Deutschland https://www.decobusgroup.de
EC	REP		