

INSTRUCTION MANUAL

HFBD-823

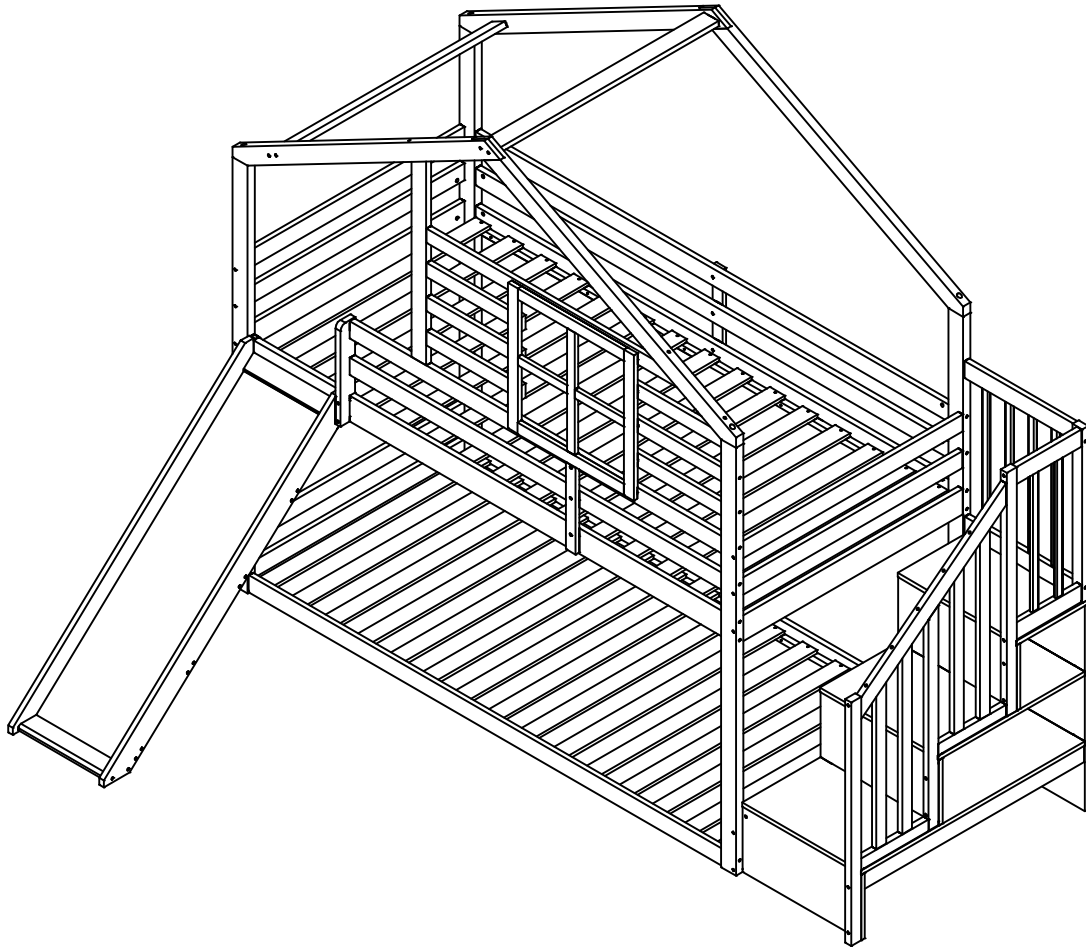

Montageanleitung

Niedriges Etagenbettgestell

NOTE:

1. When receiving the goods, please confirm the product according to the instructions. Once you find less pieces, please provide relevant pictures to contact us. We will deal it in the time.
2. Please install goods with the instruction manual.
3. It is recommended that the installation should not be too tight to adjust easily. After the structure is installed, firm the interface for more stability.

HINWEISE:

1. Wenn Sie die Ware erhalten, bestätigen Sie bitte das Produkt gemäß der Montageanleitung. Wenn Sie fehlende Teile finden, senden Sie uns bitte entsprechende Bilder. Wir werden uns umgehend darum kümmern.
2. Bitte installieren Sie die Ware gemäß der Montageanleitung.
3. Es wird empfohlen, die Installation nicht zu fest vorzunehmen, damit die Teile leicht wieder eingestellt werden können. Nachdem die Struktur installiert ist, ziehen Sie die Schnittstelle fest, um mehr Stabilität zu gewährleisten.

IMPORTANT - KEEP FOR FUTURE REFERENCE - READ CAREFULLY

EN



IMPORTANT!

- Do not leave anything in the bed or place it close to another product, which could provide a foothold or present a danger of suffocation or strangulation (e.g. strings, blind/curtain cords)
- All supplied assembly fittings should always be tightened properly. The fittings should be checked regularly and retightened as necessary. Do not use the bed if one of the parts is damaged or broken. All parts should come from the producer directly.
- Be aware of the risk of open fire and other sources of strong heat, such as electric bar fires, gas fires, etc. in the near vicinity of the bed.
- In order to prevent a risk of suffocation, all plastic and EPS parts should be removed before usage of the bed.
- Children can become trapped between the bed and the wall. To avoid risk of serious injury the distance between the bed and the wall must always be less than 65 mm or more than 300 mm.

For the corresponding article number and name of the product we refer to the sticker applied on the packaging.

This product is not designed to be dismantled.

DO NOT use if any part is broken, torn or missing. Contact us for replacement parts. Do not substitute parts.

Please open the box carefully and don't throw away the box yet during assembly. The box is required in case of a possible return of the product.

The assembly is done preferably by two people. Be cautious not to damage any parts when doing the assembly alone. Carefully place the parts on a rug or carton before assembly to prevent scratches etc.

The length and width of the mattress shall be equal to the inner dimensions of the bed 200x90 .

Do not leave any screws untightened as a child may hurt itself or clothes (f.e. cords hanging on a pacifier or collars) can get stuck behind them and cause a risk of strangulation.

Only use appropriate tools for fastening the supplied assembly fittings. In case electrical tools are used be aware to limit the torque settings to prevent damage to the wood in case too much force is applied.

Cleaning instruction: use a damp cloth and some natural soap. Avoid the usage of aggressive cleaning agents.

Although we only use coatings that comply with regulations, we suggest to place the bed in a well-ventilated area for a few days so the specific odour that comes with a new product can disappear before usage.

This item is not intended for rent.

This product is not intended for use in commercial establishments, institutions, hospitals, etc.

WICHTIG! AUFMERKSAM DURCHLESEN UND FÜR SPÄTERES NACHSCHLAGEN AUFBEWAHREN

DE



ACHTUNG!

- Es darf nichts im Bett liegen bleiben und kein anderes Produkt in die Nähe des Bettes kommen, das vom Kind zum Klettern benutzt werden kann oder das ein potenzielles Risiko zum Erstickten oder Würgen darstellen kann (wie zum Beispiel Schnüre, Verdunkelungs- und Vorhangschnüre).
- die Befestigungsschrauben müssen regelmäßig überprüft und bei Bedarf festgezogen werden. Verwenden Sie das juniorbett nicht, wenn ein Teil beschädigt oder gebrochen ist, und / oder fehlt. Verwenden Sie nur Ersatz- oder Zusatzteile, die vom Produzenten kommen.
- Das juniorbett sollte nicht in der Nähe eines offenen Feuers oder anderer extremer Wärmequellen wie Elektroheizungen, Gasheizungen usw. aufgestellt werden.
- Um Erstickungsgefahr zu vermeiden, sollten alle Kunststoff- und EPS-Teile vor Benutzung des juniorbett entfernt werden.
- Kinder könnten zwischen Bett und Wand steckenbleiben. Zur Vermeidung von Verletzungen muss der Abstand zwischen Bett und Wand immer weniger als 65 mm oder mehr als 300 mm betragen.

Die entsprechende Artikelnummer und den Namen des Produktes finden Sie auf dem Aufkleber der Verpackung.

Dieses Produkt ist nicht für die Demontage konzipiert.

Verwenden Sie das Produkt NICHT, wenn etwas beschädigt ist oder Teile fehlen. Wenn Ersatzteile benötigt werden, fragen Sie bei Wir nach Teilen. Nicht mit Teilen anderer Marken/Modelle ergänzen.

Öffnen Sie die Verpackung vorsichtig und bewahren Sie sie während der Montage eine Weile auf. Diese wird bei einer eventuellen Rückgabe des juniorbett benötigt.

Die Montage erfolgt vorzugsweise von zwei Personen. Achten Sie darauf, keine Teile zu beschädigen, sollten Sie das Produkt alleine zusammenbauen. Legen Sie die Teile vor dem Zusammenbau vorsichtig auf einen Teppich oder Karton, um Kratzer etc. Zu vermeiden.

Die Länge und Breite der Matratze muss den Innenabmessungen 200x90 cm des Kleinkinderbettes entsprechen.

Das juniorbett ist nur dann betriebsbereit, wenn die Verriegelungsmechanismen ausreichend eingerastet sind und handfest angezogen wurden. Lassen Sie keine Schrauben locker, da sich ein Kind oder die Kleidung (z. B. Schnuren die an Nuckeln oder Kragen hängen) hängen bleiben und die Gefahr einer Strangulation verursachen können.

Verwenden Sie zum Befestigen der Schrauben das richtige Werkzeug. Wenn elektrische Geräte verwendet werden, stellen Sie diese nicht mit zu starker Torsion ein, damit beim Holz keine Beschädigungen auftreten.

Reinigen Sie das Produkt mit einem feuchten Tuch und etwas natürlicher Seife. Verwenden Sie keine aggressiven Reinigungsmittel.

Obwohl wir für die Herstellung unserer Möbel nur unschädliche Lacke verwenden, empfehlen wir Ihnen, das juniorbett für ein paar Tage in einem gut belüfteten Bereich zu platzieren, damit der spezifische Geruch der mit einem neuen Produkt einhergeht, vor Gebrauch verschwinden kann.

Dieses Produkt ist nicht zur Vermietung bestimmt.





Dieses Produkt ist nicht für gewerbliche Verwendung vorgesehen (z.B: in Institutionen, Krankenhäusern usw.).

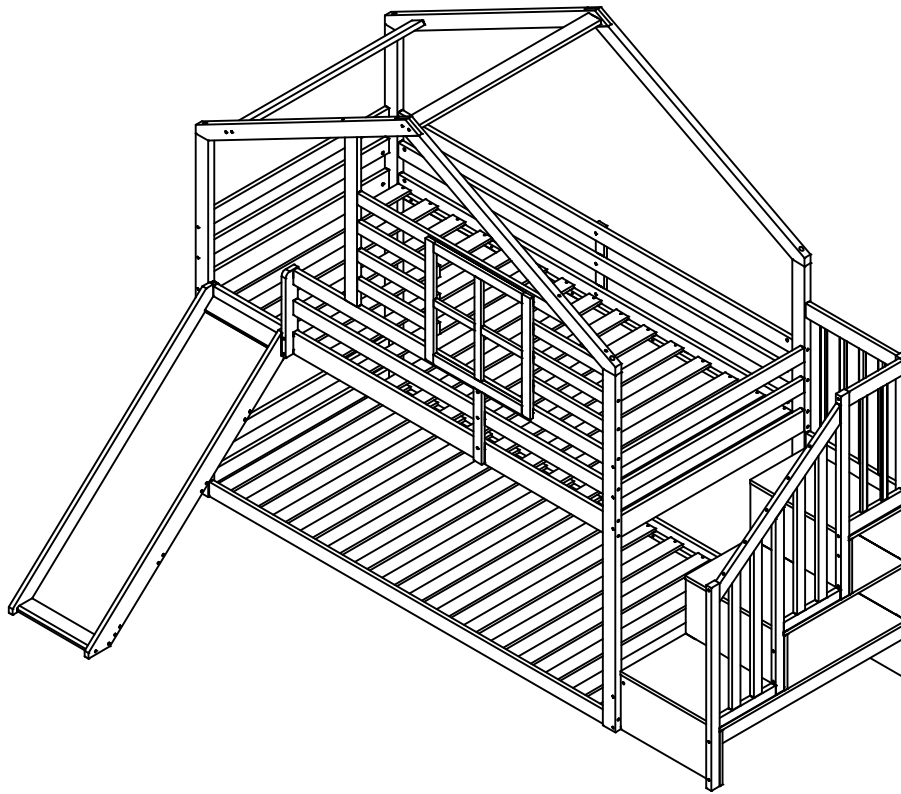



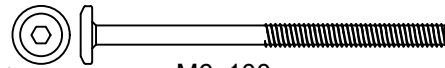
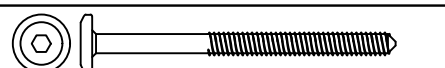
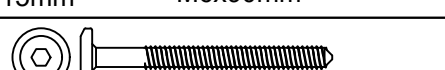

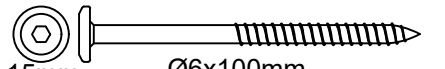
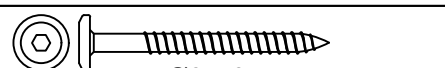
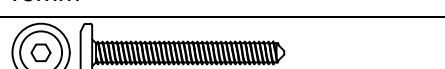
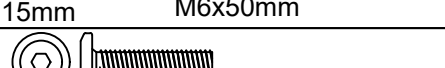
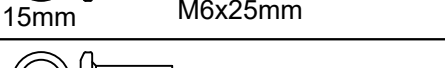
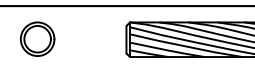

Packing list!

Carton Number	Part Number	Quantity	Part Number	Quantity
Carton 1 HFBD-823WH-1	1	1	9	1
	2	1	10	1
	3	1	11	2
	4	1	12	8
	5	1	17	2
	6	1	18	1
	7	2	53	2
	8	2		
Carton Number	Part Number	Quantity	Part Number	Quantity
Carton 2 HFBD-823WH-2	13	1	33	1
	14	1	34	1
	15	1	35	1
	16	1	42	2
	19	1	43	6
	20	1	44	2
	21	3	45	1
	22	1	46	1
	23	1	47	1
	24	2	48	1
	25	1	49	2
	26	2	50	2
	27	1	51	1
	28	1	52	2
	29	2	54	2
	30	1	Hardware	1
	31	1	Instruction book	1
	32	4		
Carton Number	Part Number	Quantity		
Carton 3 HFBD-823WH-3	36	2		
	37	1		
	38	1		
	39	1		
	40	1		
	41	1		
	Slats	2		

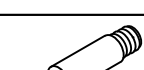

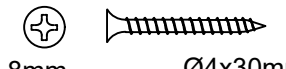
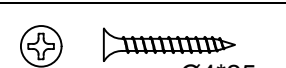
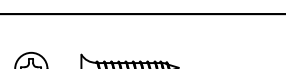
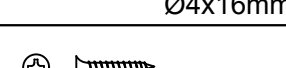
HARDWARE

A	 15mm M6x100mm	20
B	 15mm M6x90mm	05
C	 15mm M6x70mm	28
D	 Ø10x13mm	53
E	 15mm Ø6x100mm	14
F	 15mm Ø6x70mm	36
G	 15mm M6x50mm	07
H	 15mm M6x25mm	06
I	 15mm M8x20mm	13
J	 8mm Ø8x30mm	69
K	 Ø5x50mm	12
L		02

M		02
N	 20x20x15mm	03
O	 M6x40mm	12
P	 Ø15x11mm	12
Q	 8mm Ø4x30mm	72
R	 Ø4*25mm	14
S	 Ø4x16mm	22
T	 Ø3x12mm	01
U	 4mm	02
V	 3mm	01
W	 Ø20mm	01

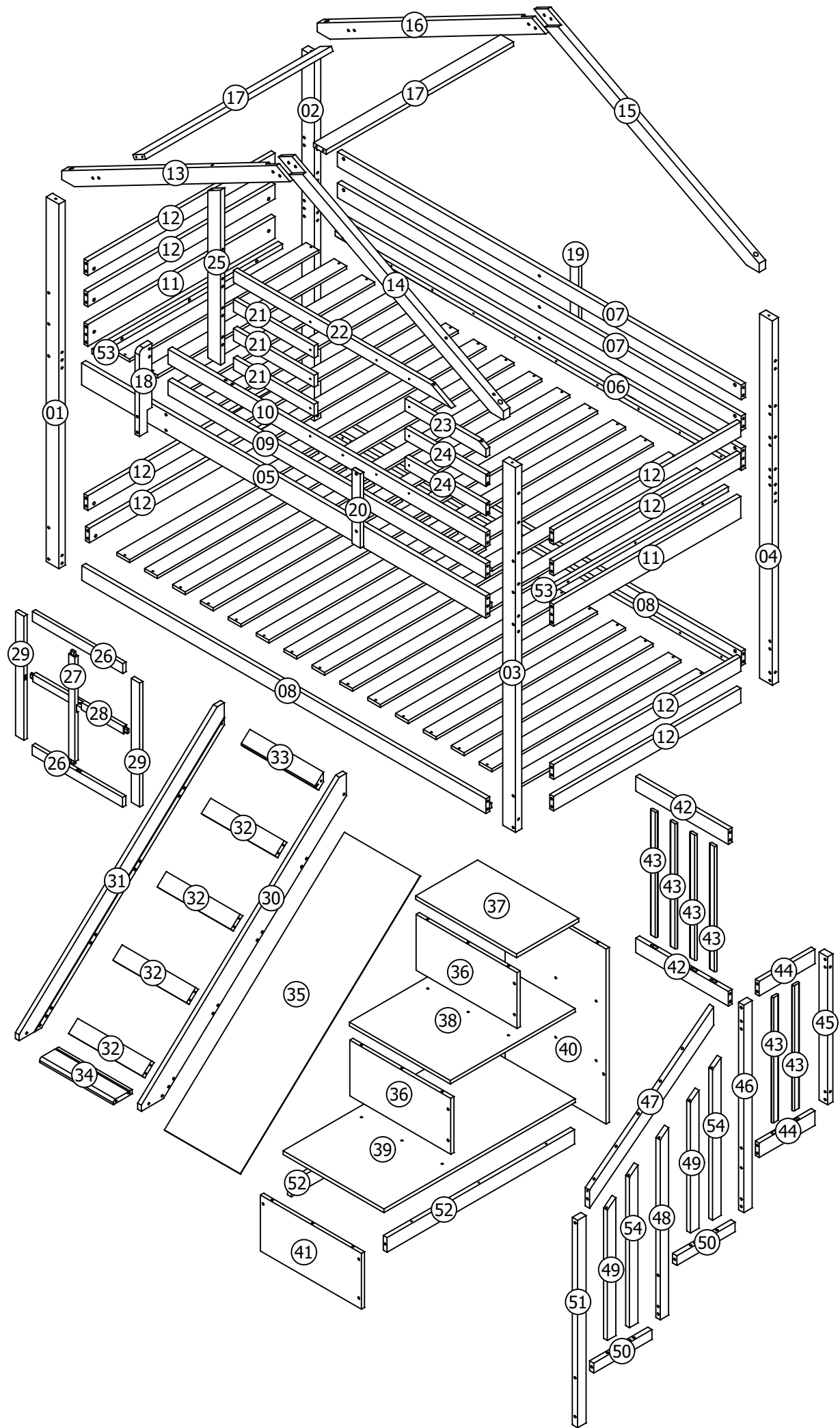

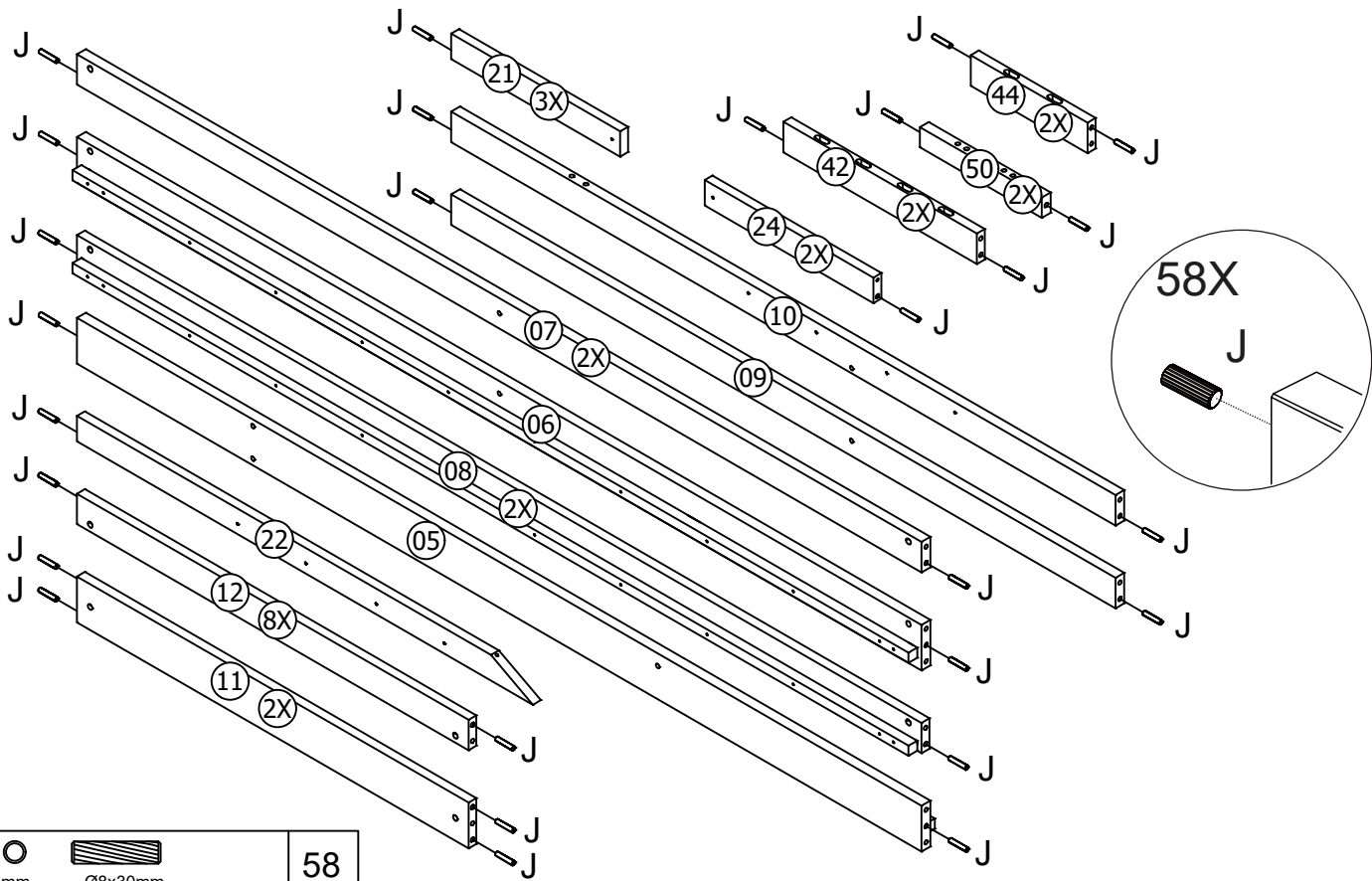

01

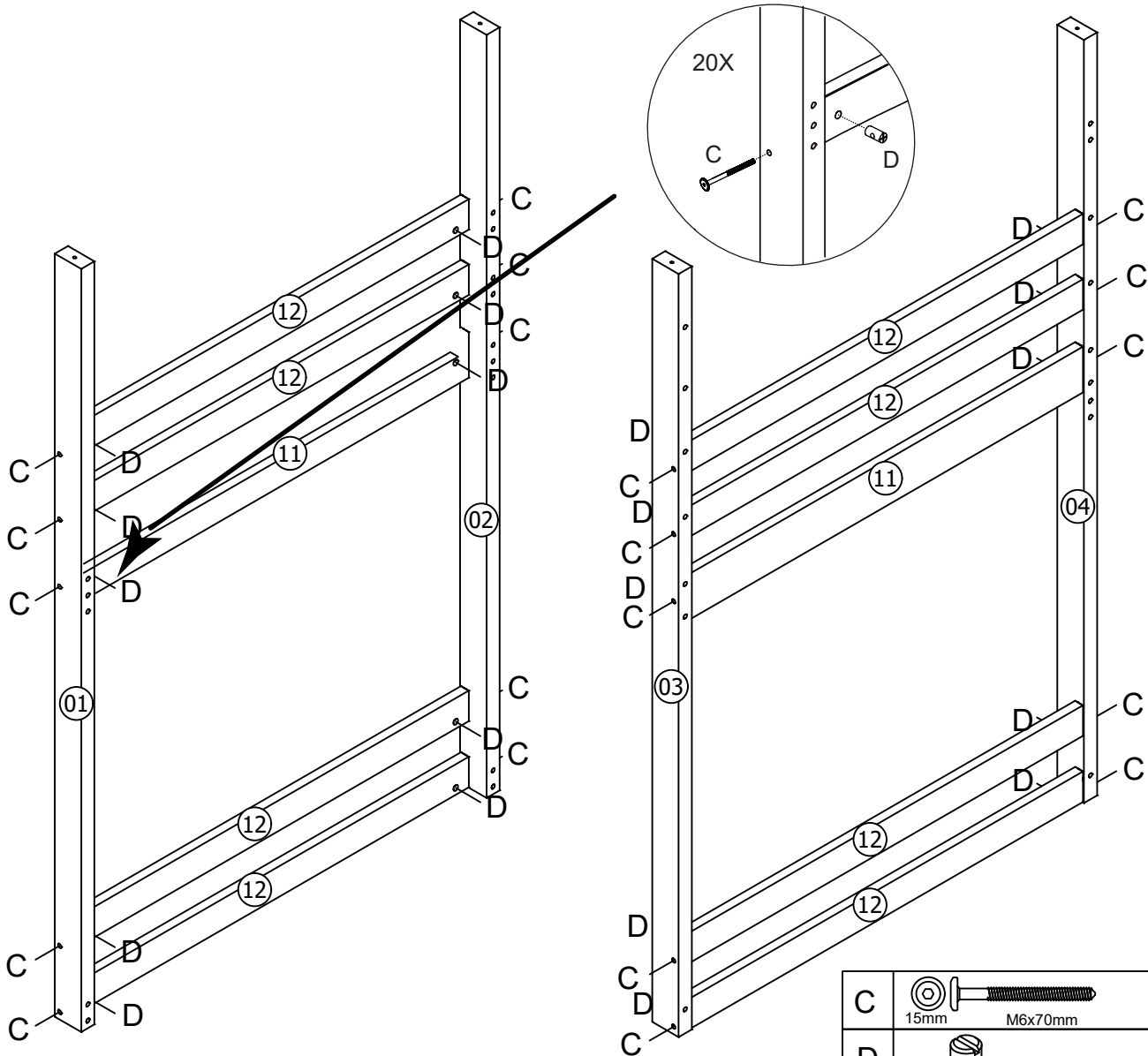

J	○		58
	8mm	Ø8x30mm	

02

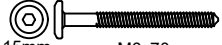

C		20
	15mm M6x70mm	
D		20
	Ø10x13mm	

03

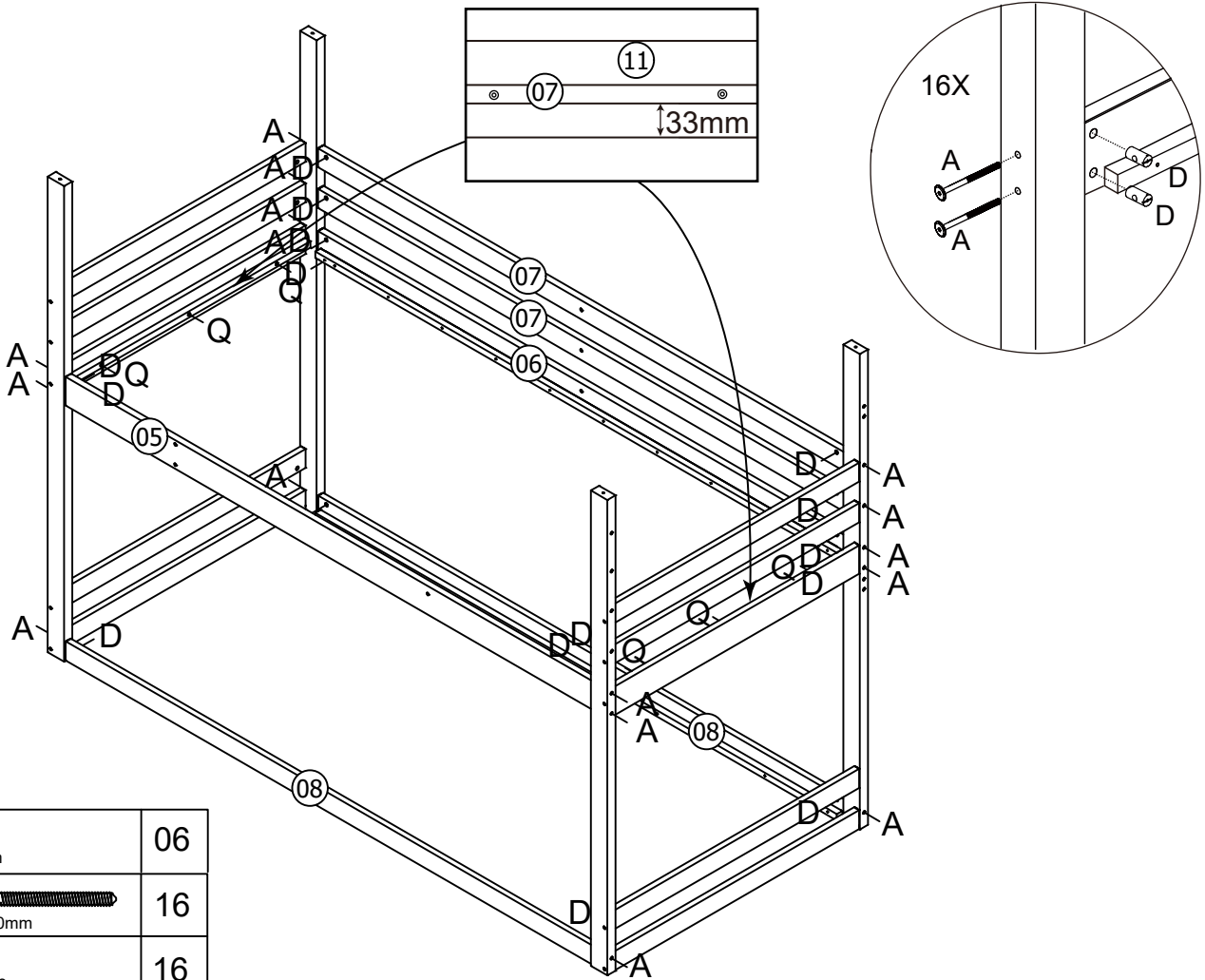

Q	8mm Ø4x30mm	06
A	15mm M6x100mm	16
D	Ø10x13mm	16

04

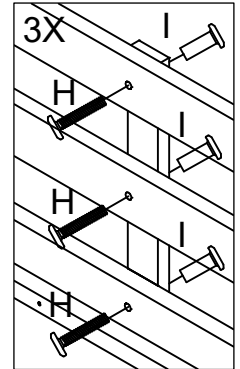
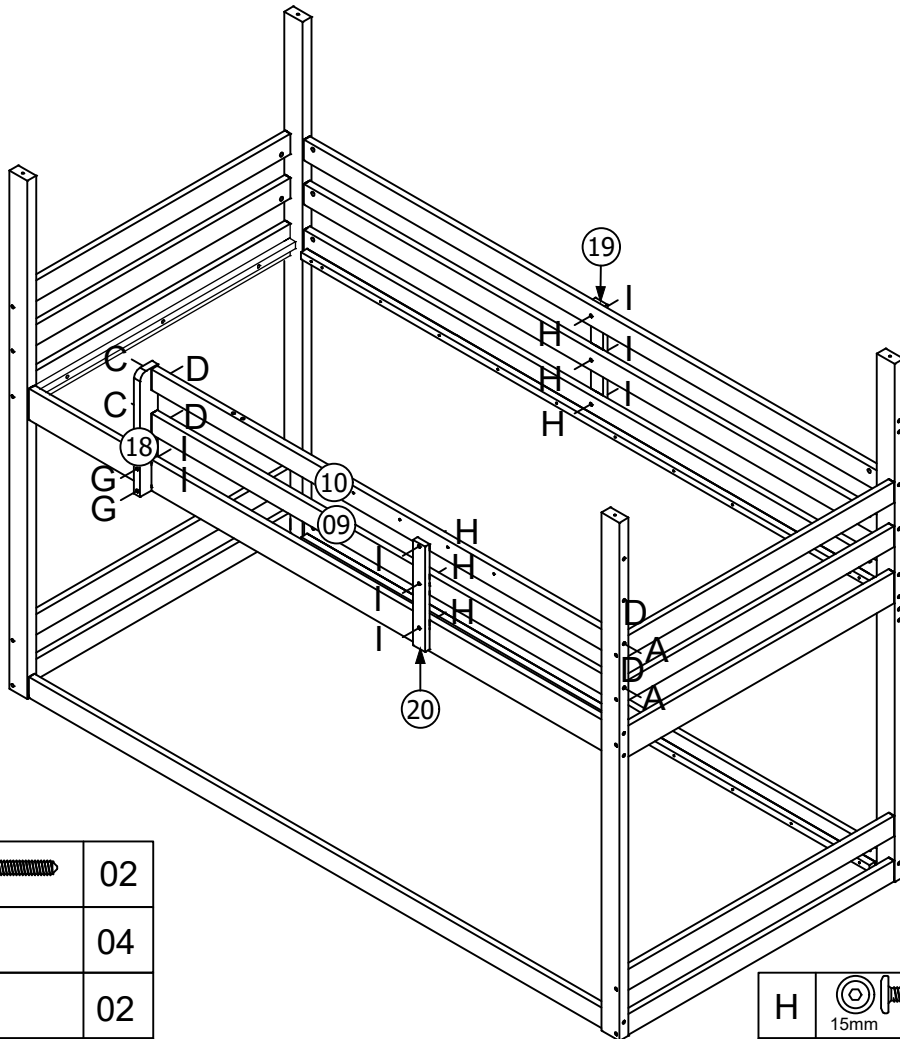
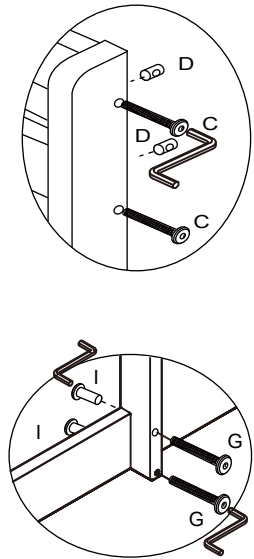



A	15mm M6x100mm	02
D	Ø10x13mm	04
C	15mm M6x70mm	02
G	15mm M6x50mm	02

H	15mm M6x25mm	06
I	15mm M8x20mm	08

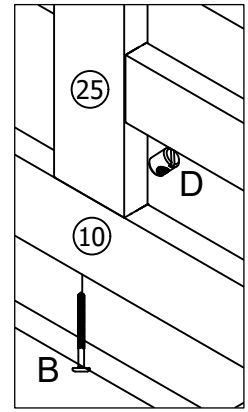
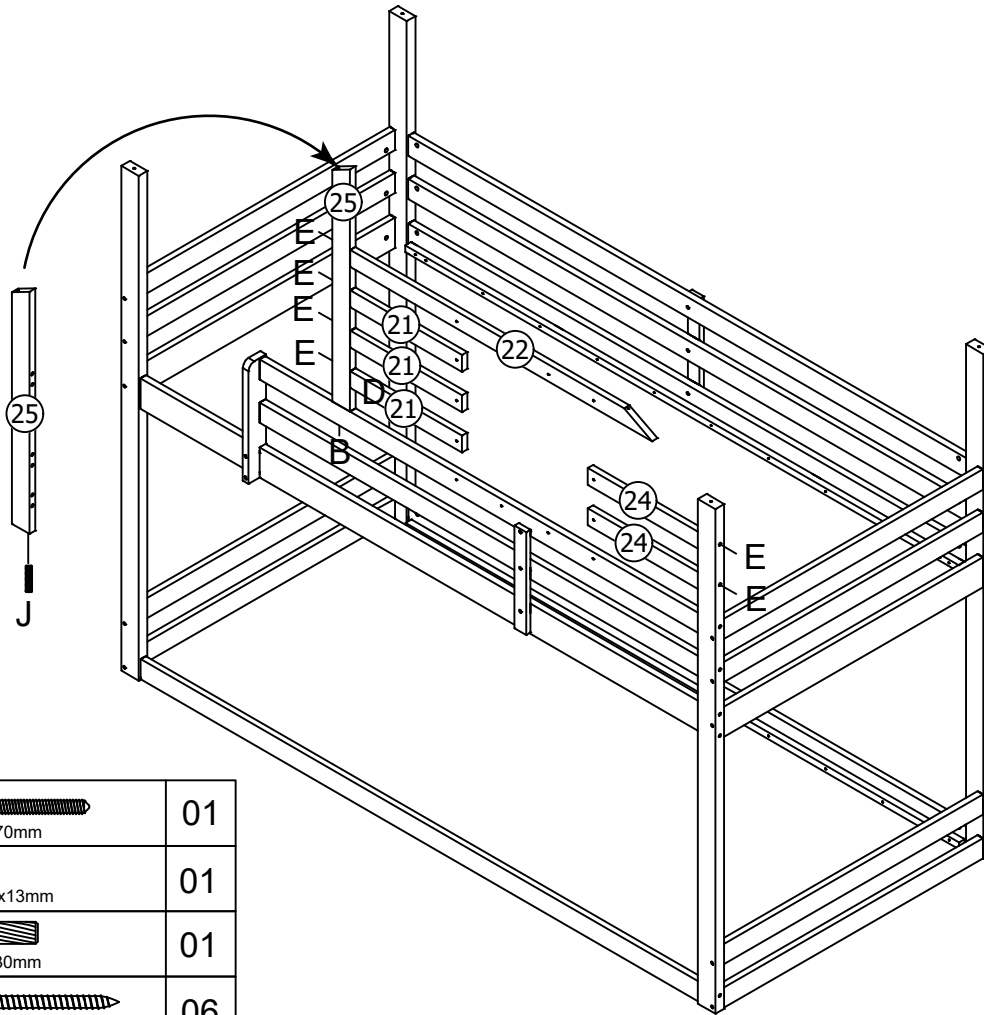
05

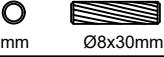
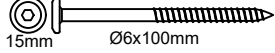

B		01
D		01
J		01
E		06

06

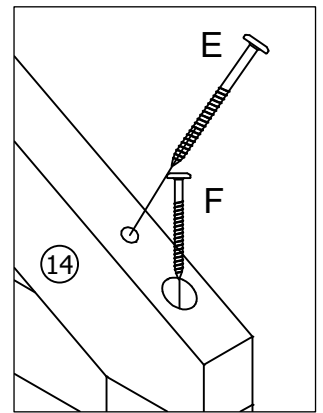
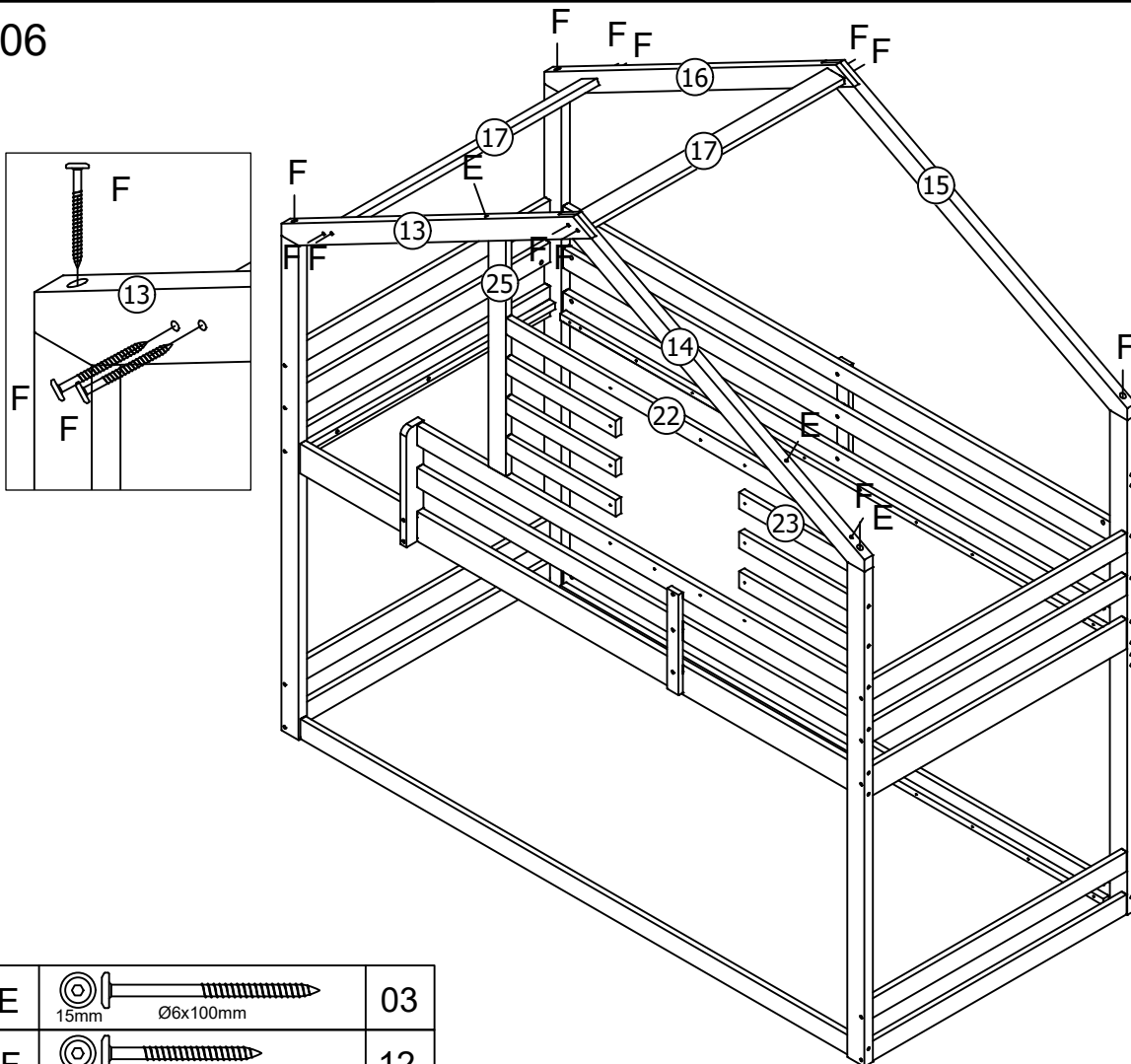

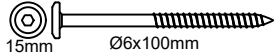
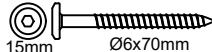
E		03
F		12

07

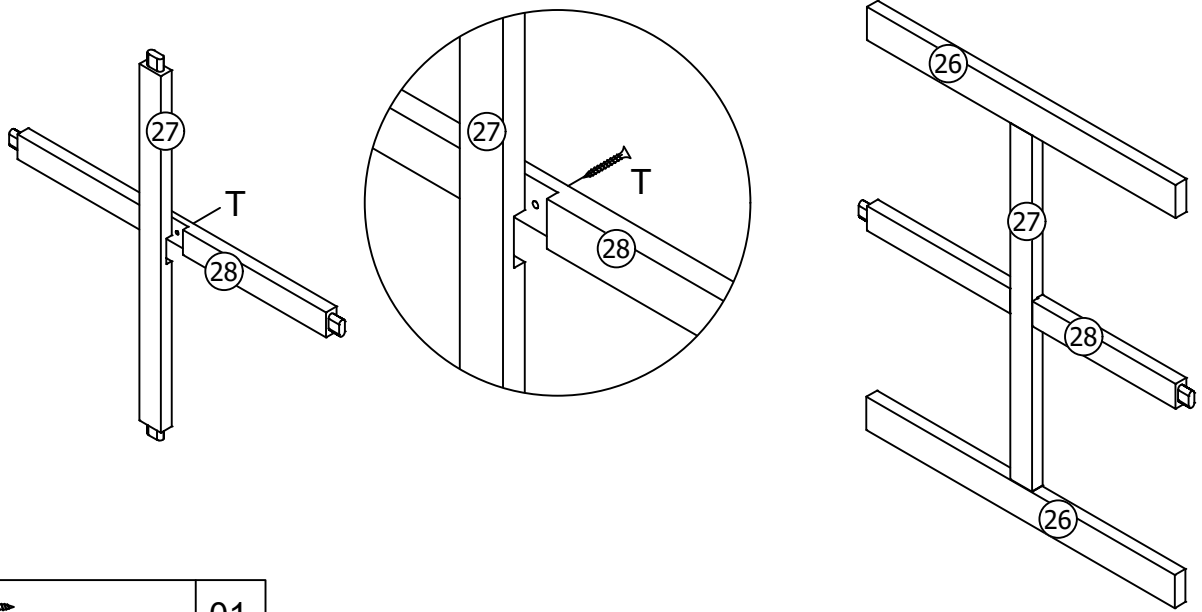

T

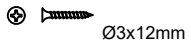

01

08

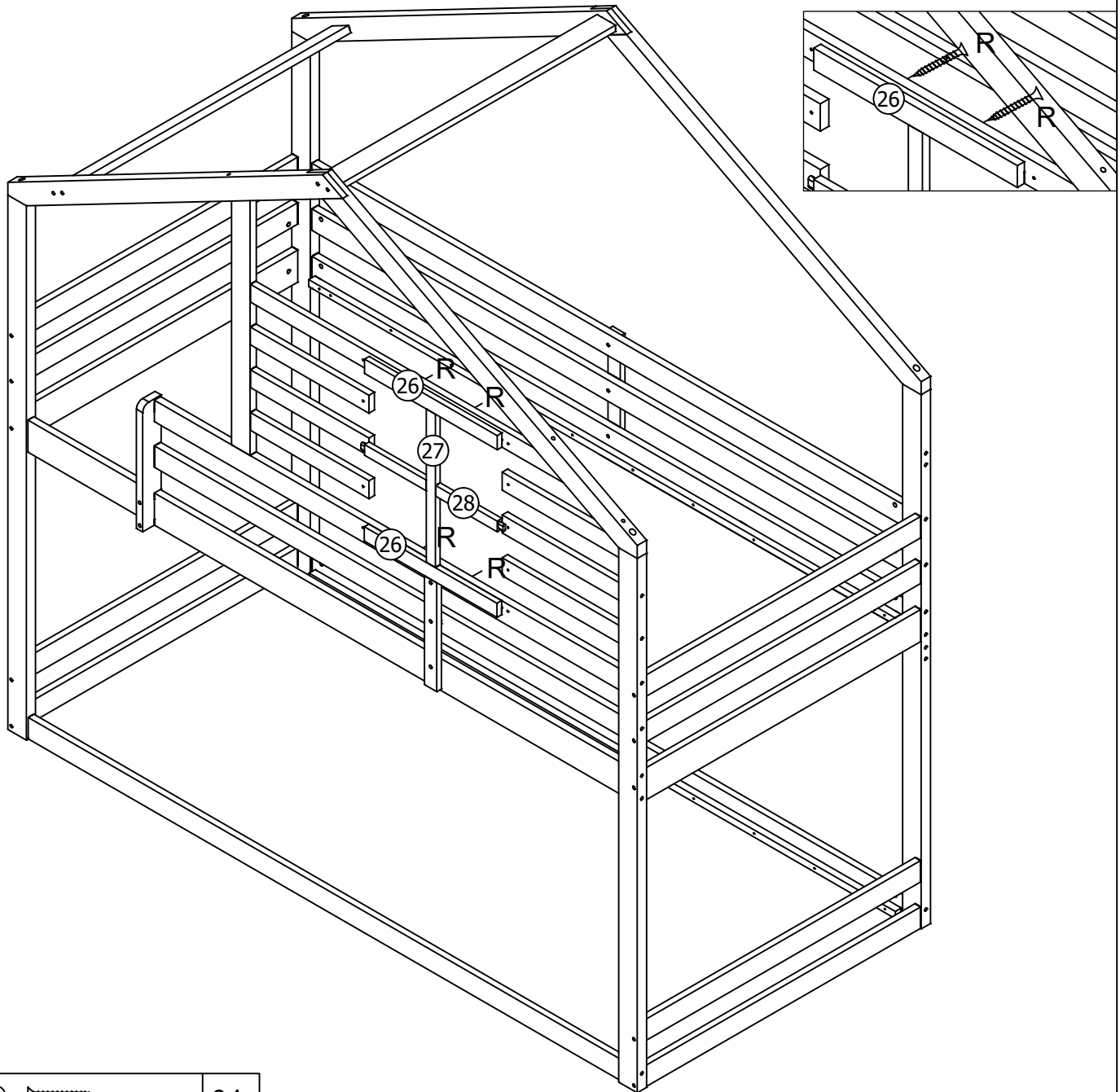

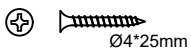

R

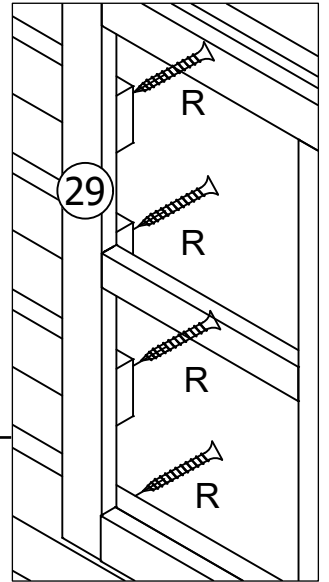
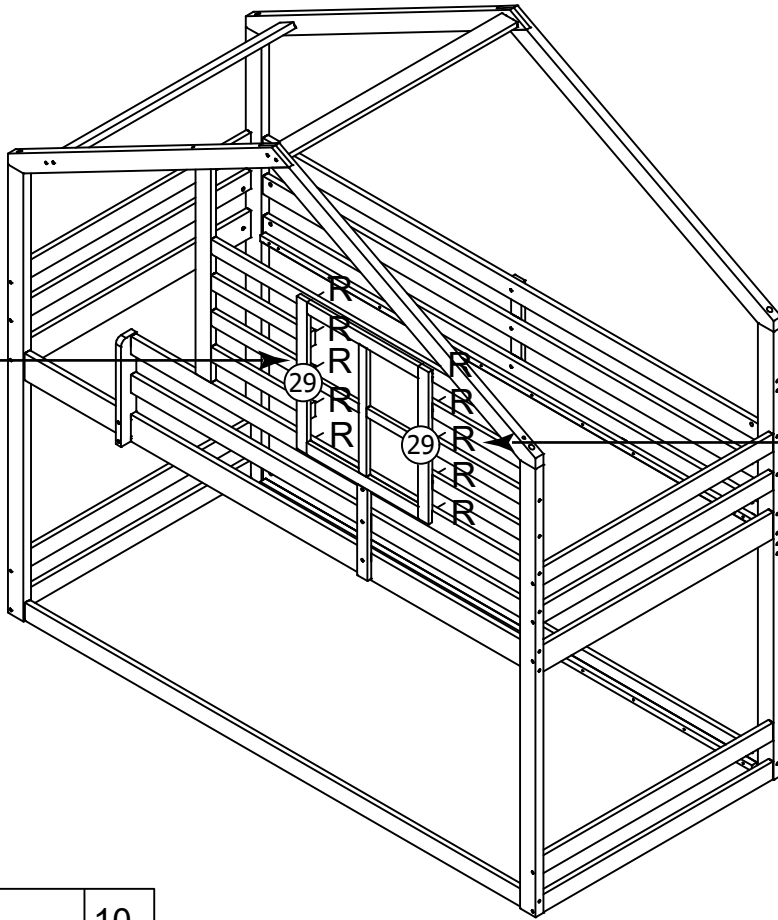
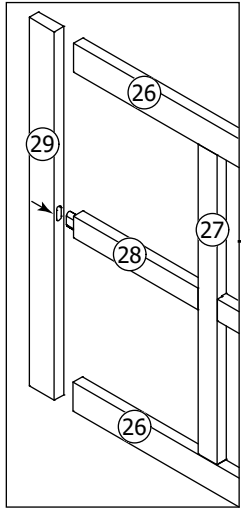

04

09



R	  Ø4*25mm	10
---	--	----

10

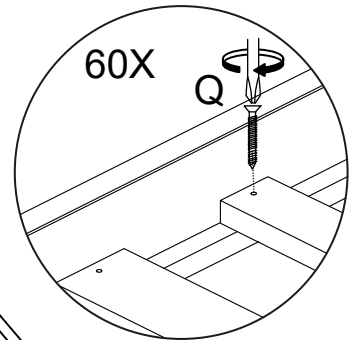
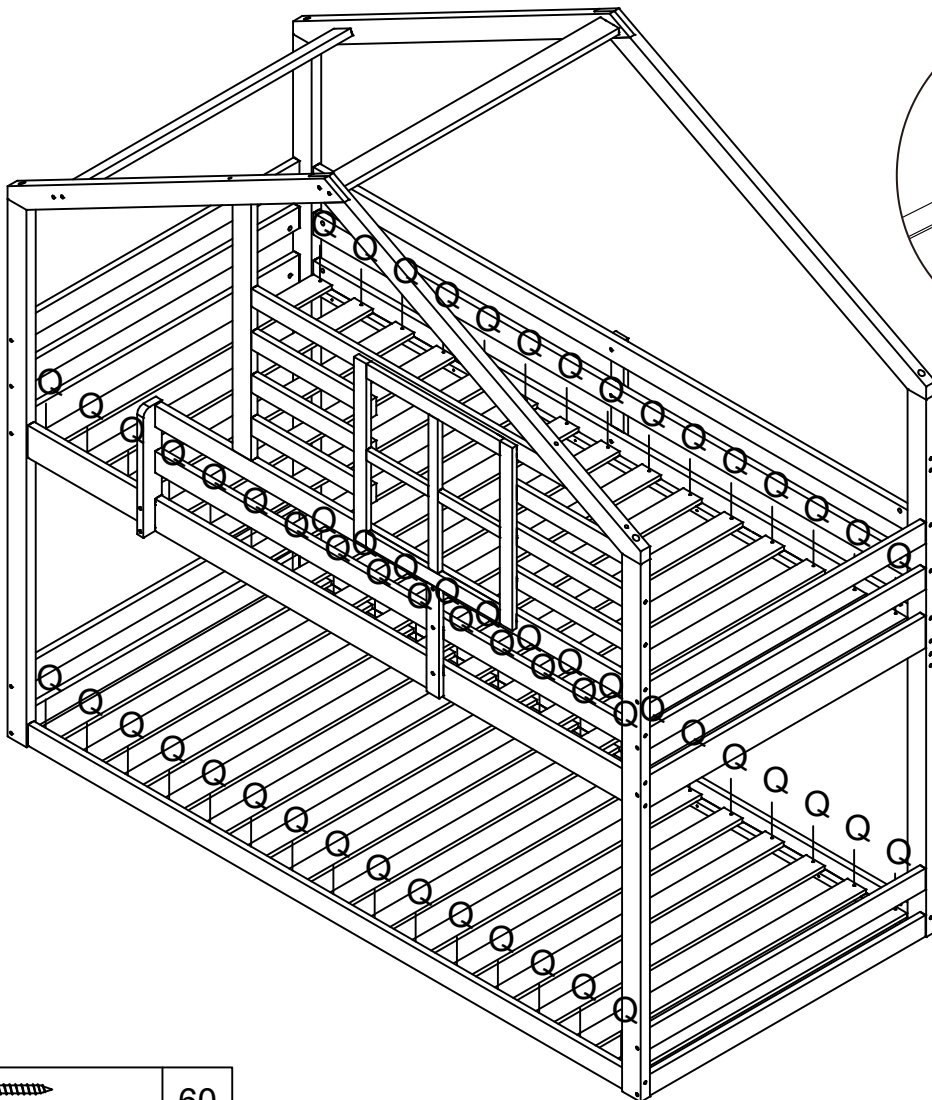

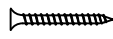
Q	  8mm Ø4x30mm	60
---	--	----

11

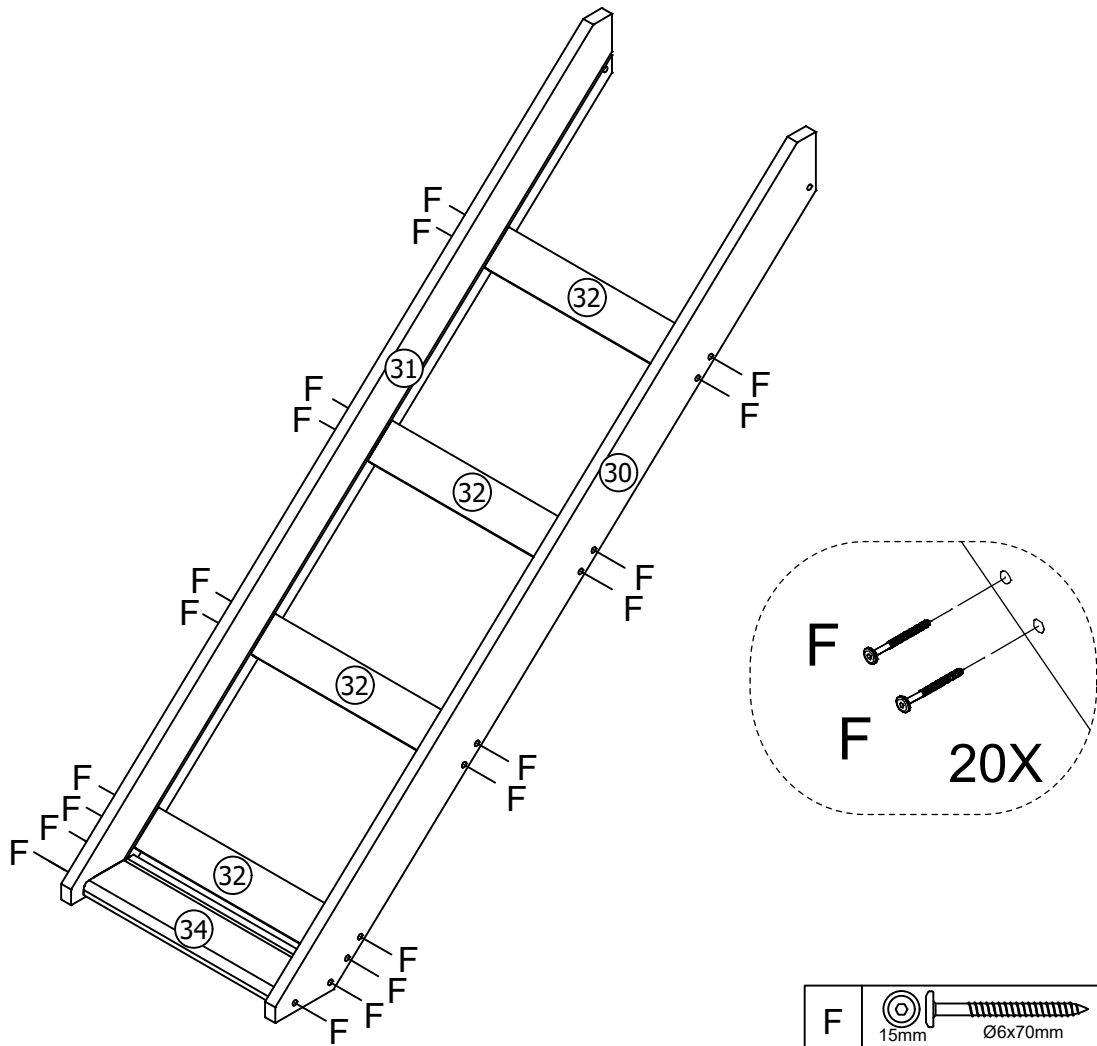

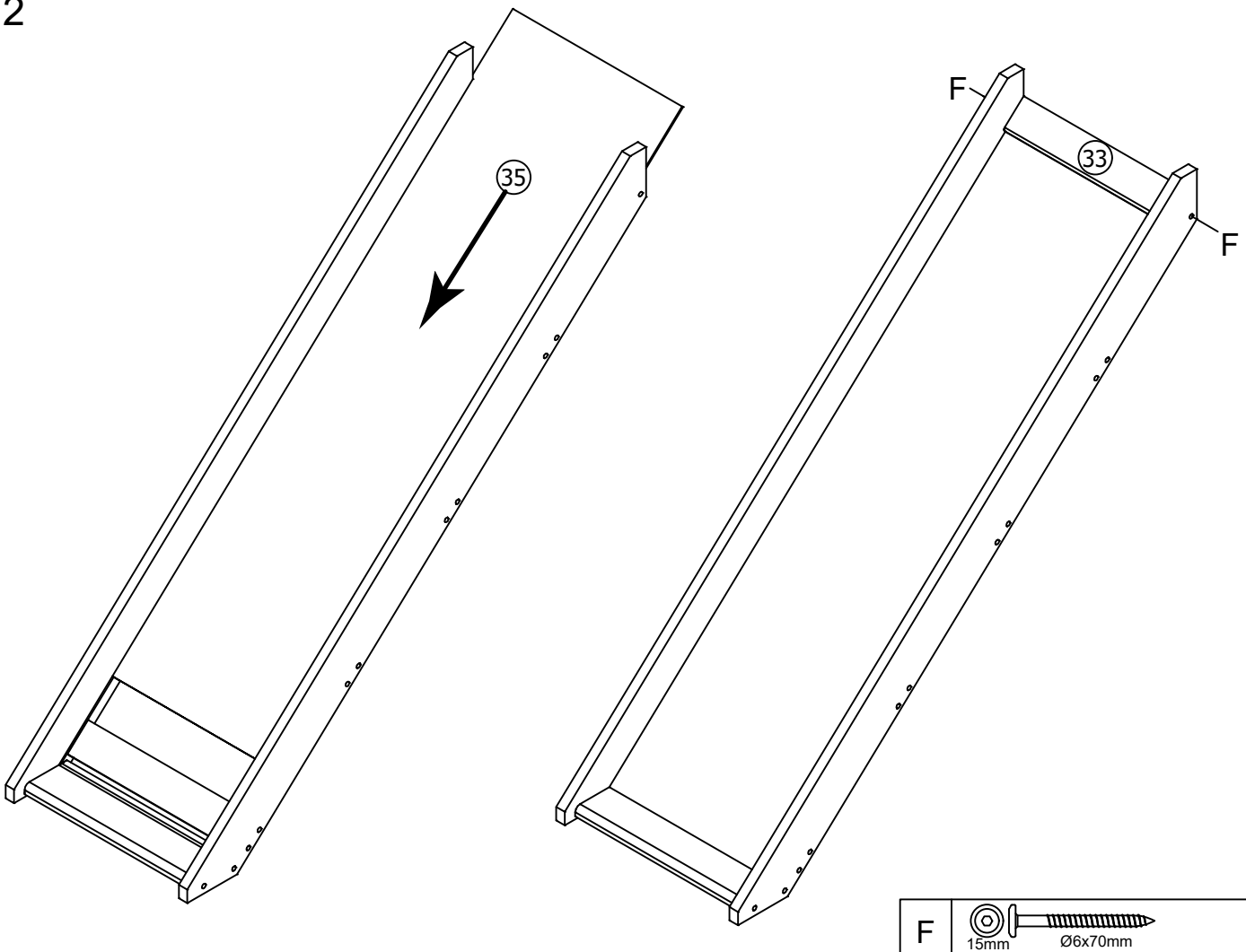

12



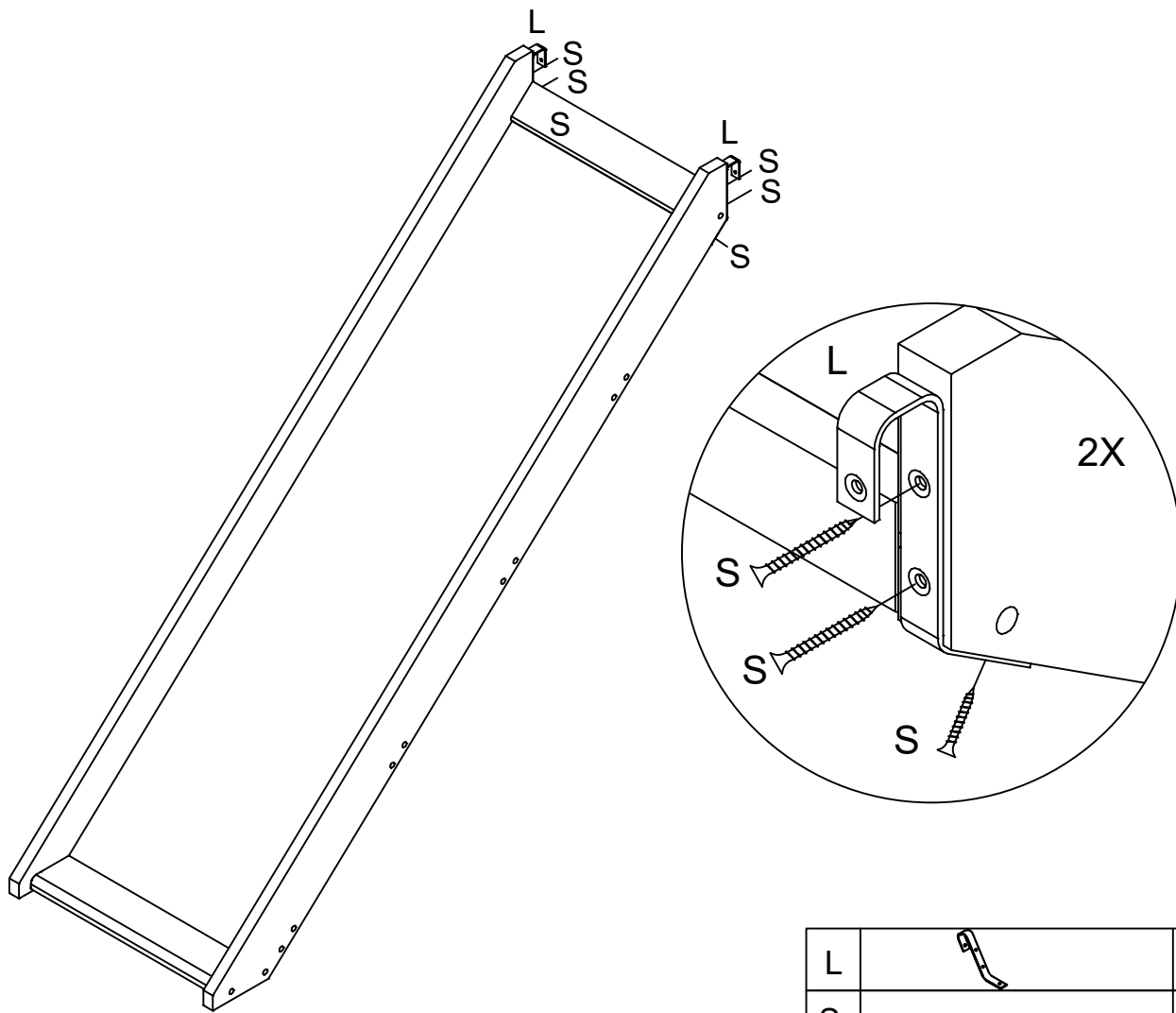

13

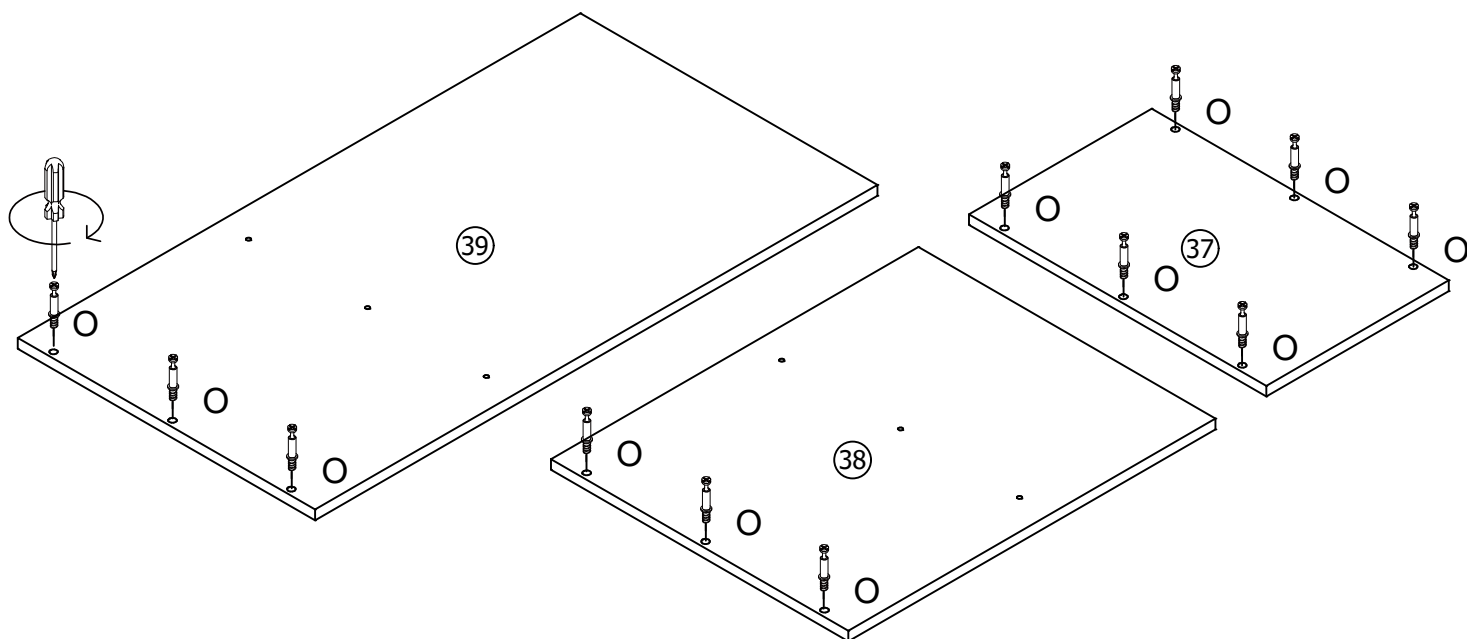

L		02
S	 Ø4x16mm	06

14



O	 M6x40mm	12
---	---	----

15

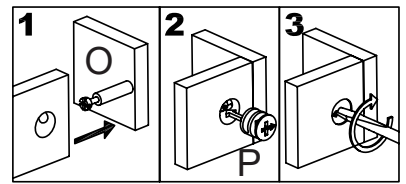
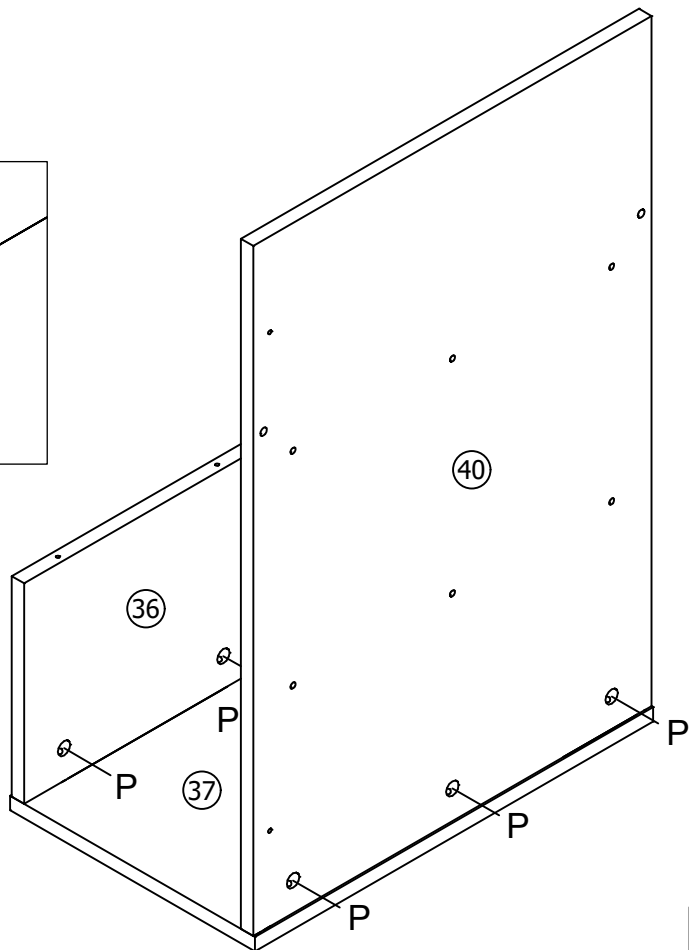
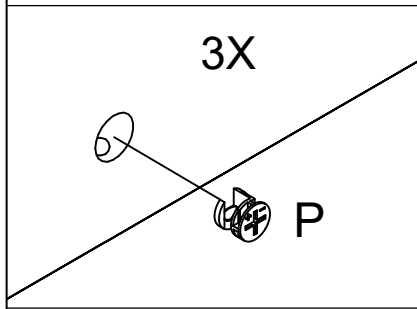

P		Ø15x11mm	06
---	--	----------	----

16

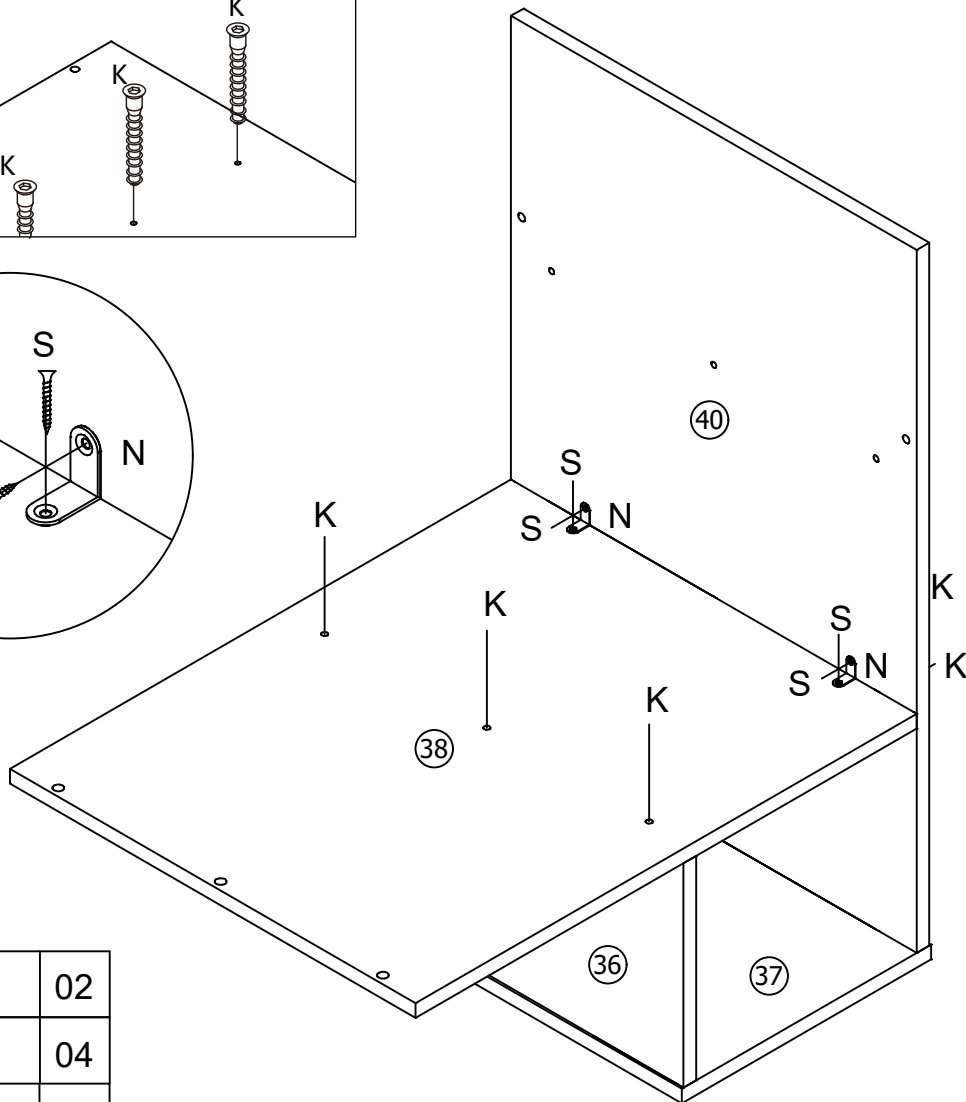
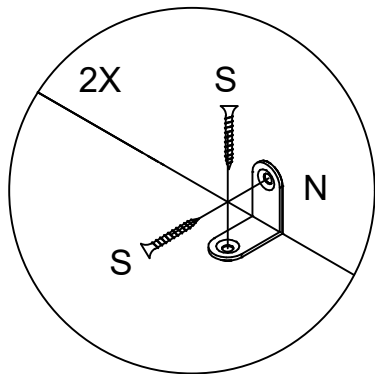
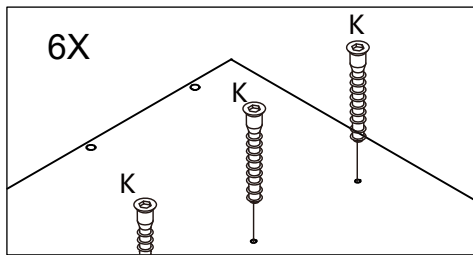

N	20x20x15mm	02
S	Ø4x16mm	04
K	7mm Ø5x50mm	06

17

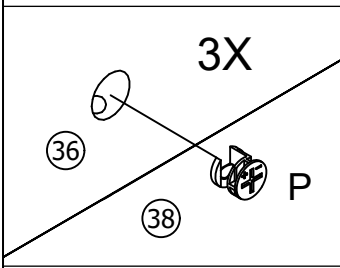
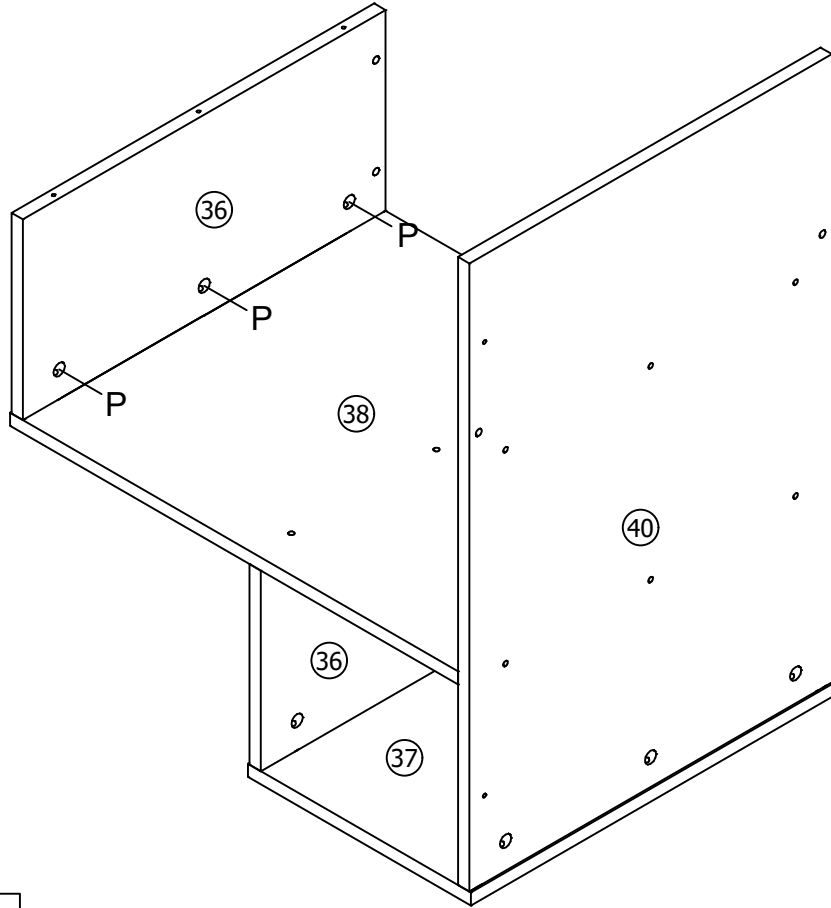
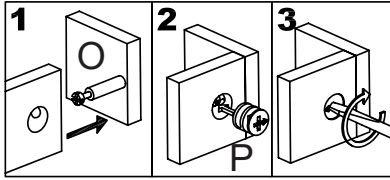

P		Ø15x11mm	03
---	---	----------	----

18

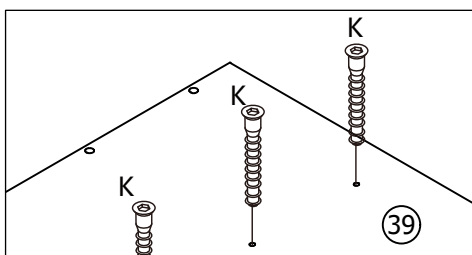
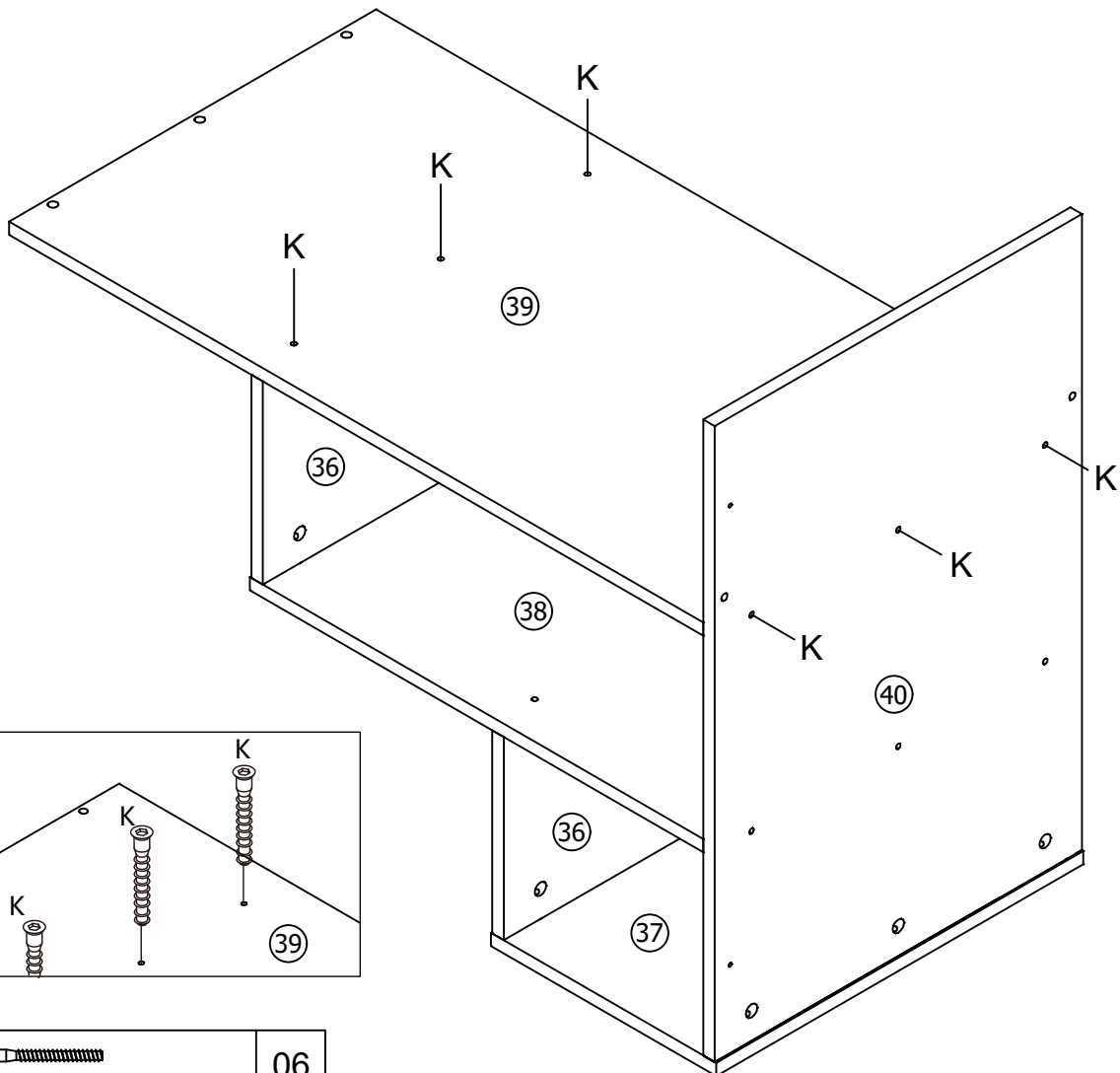

K		7mm Ø5x50mm	06
---	---	-------------	----

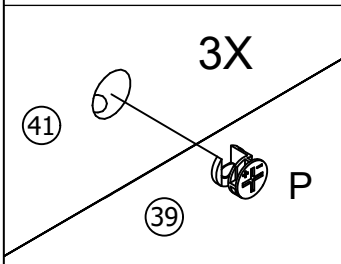
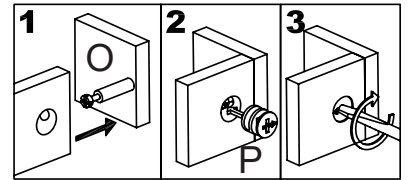
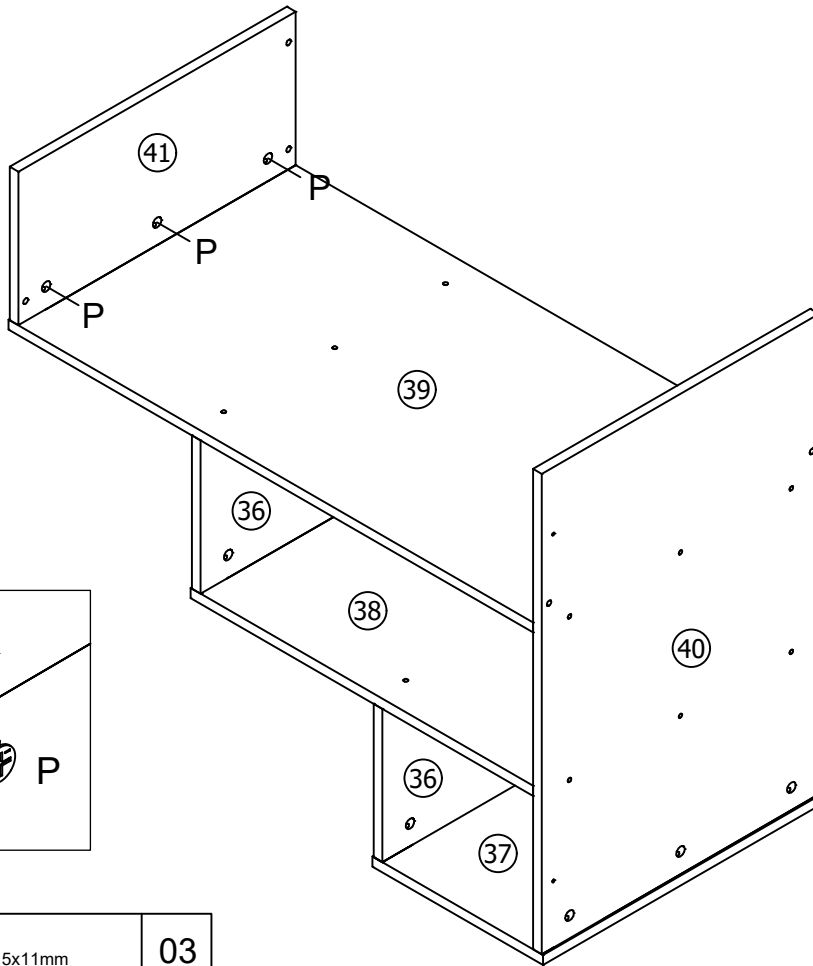

19

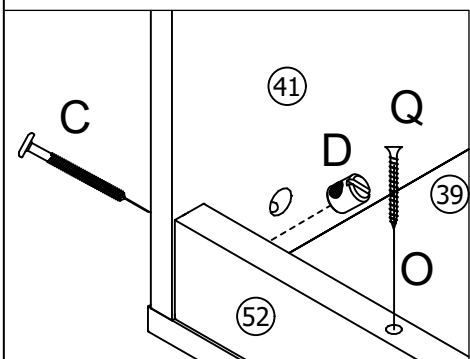
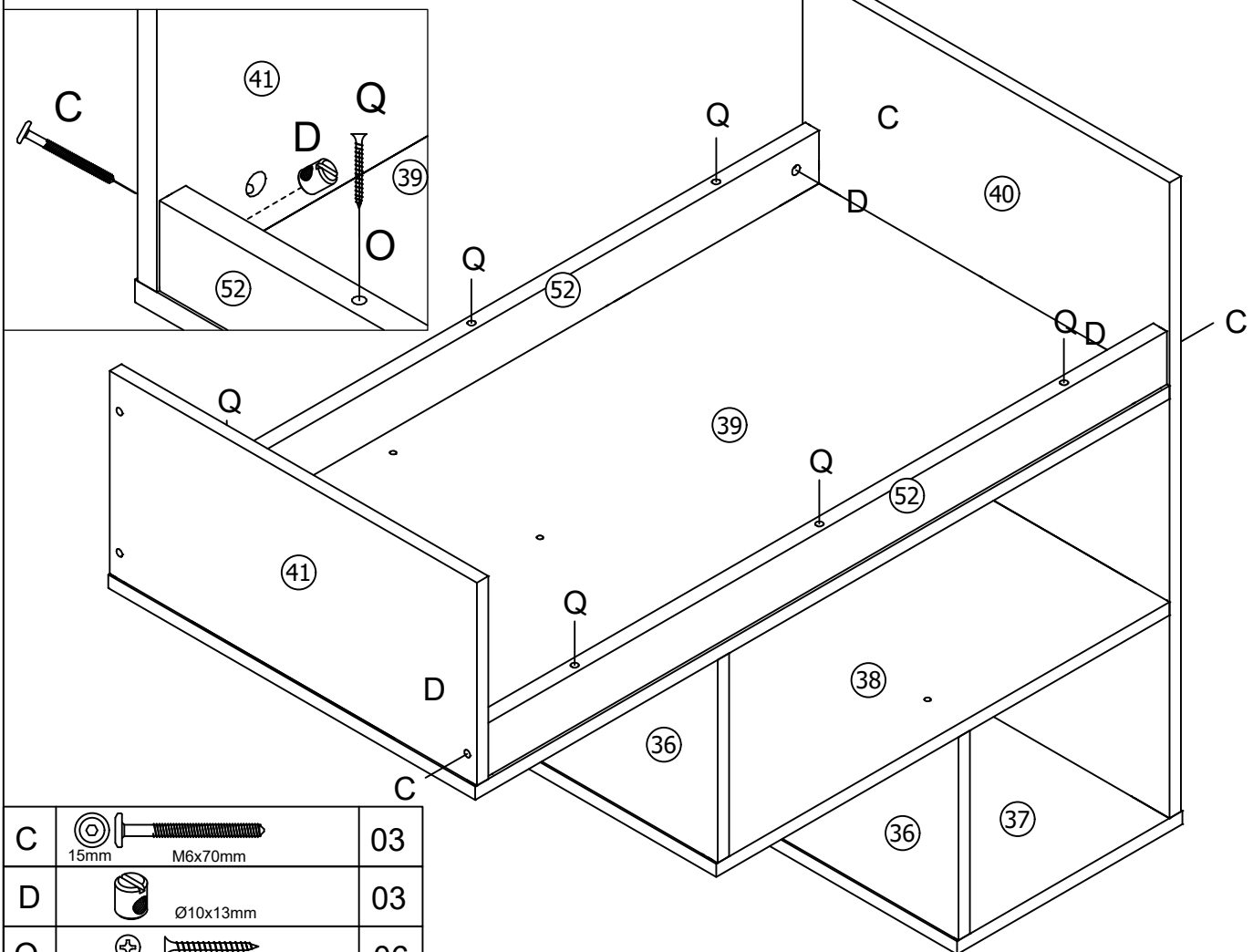

P		Ø15x11mm	03
---	--	----------	----

20

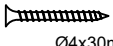

C		15mm M6x70mm	03
D		Ø10x13mm	03
Q		8mm Ø4x30mm	06

21

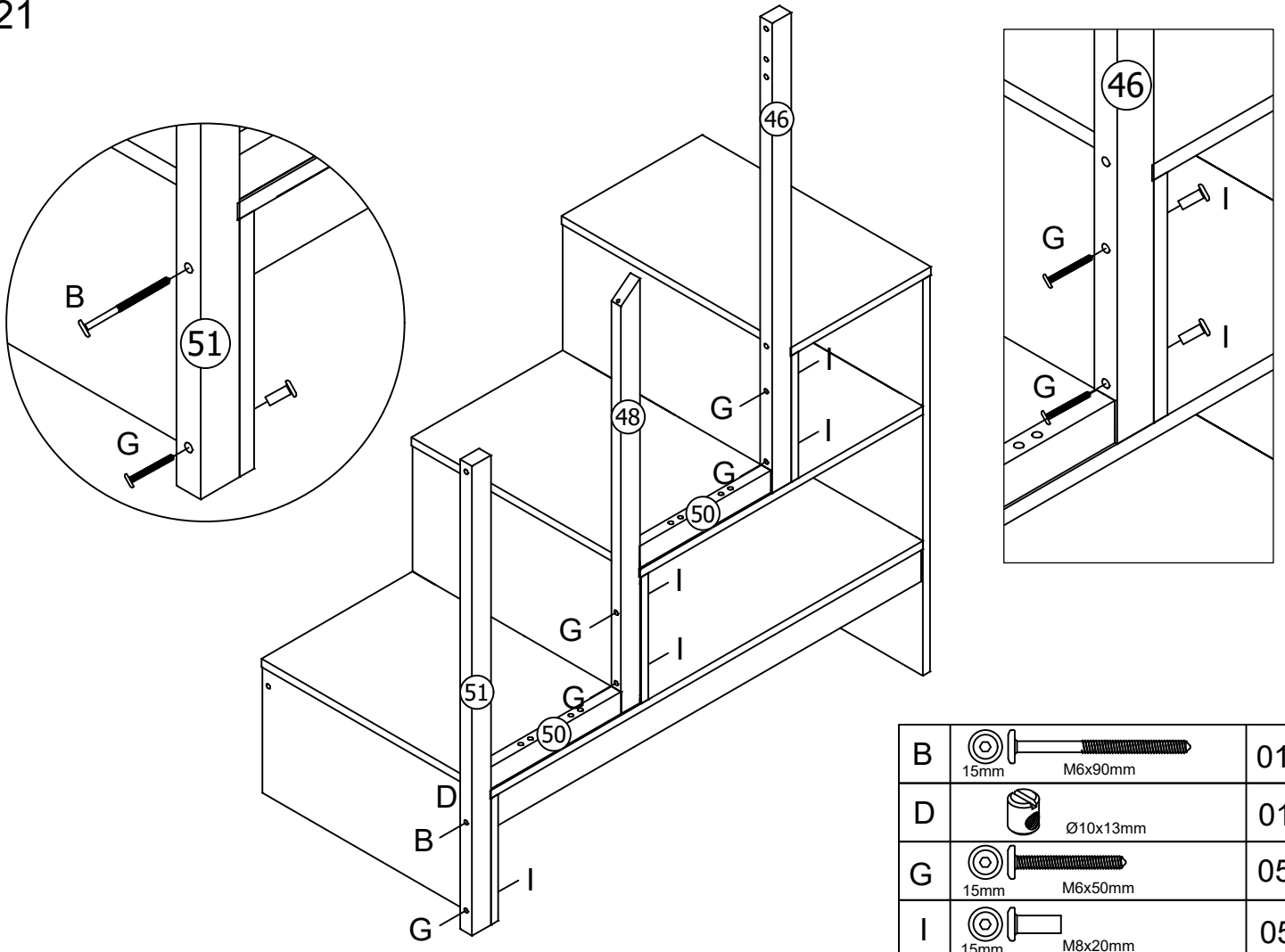



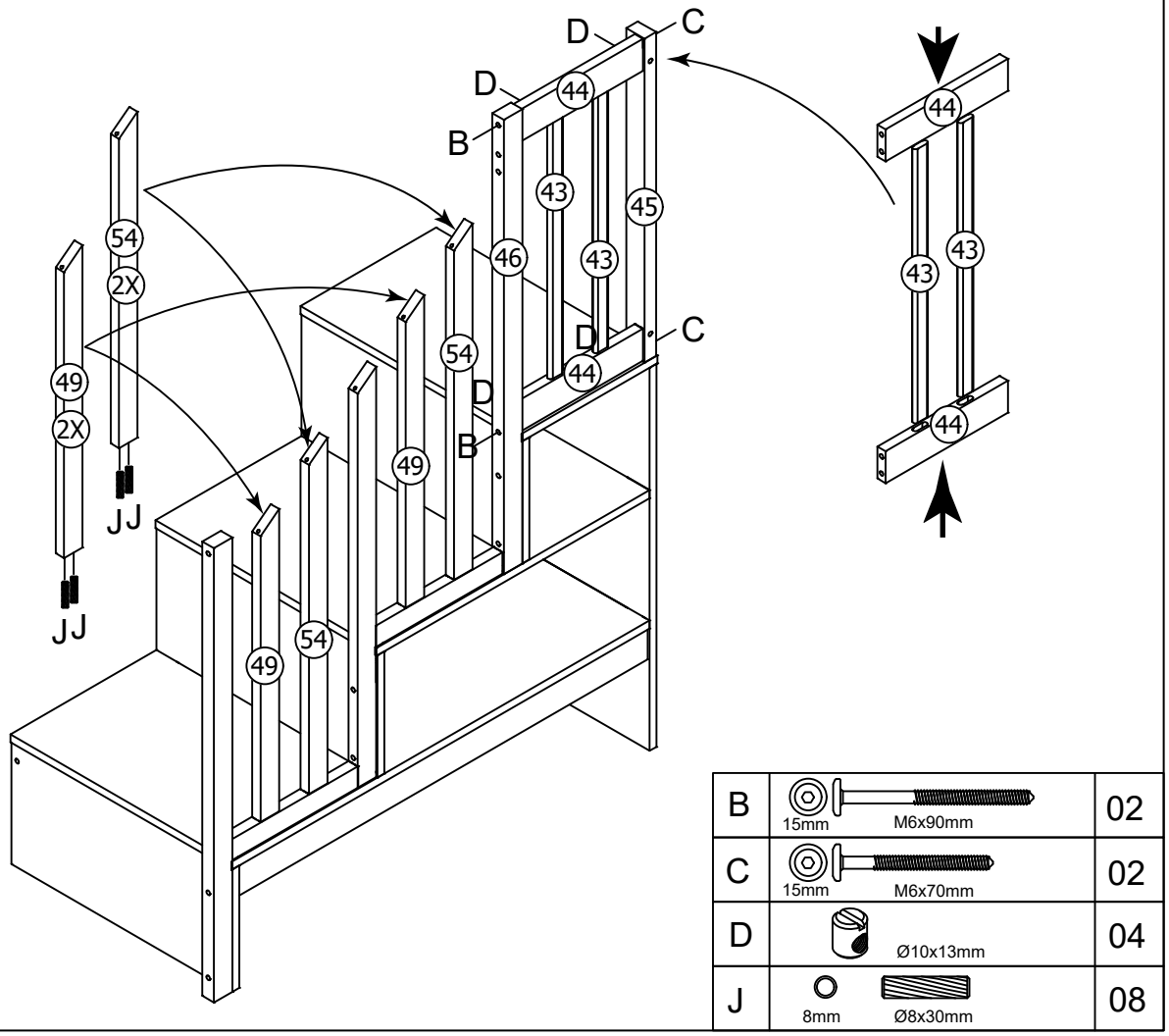

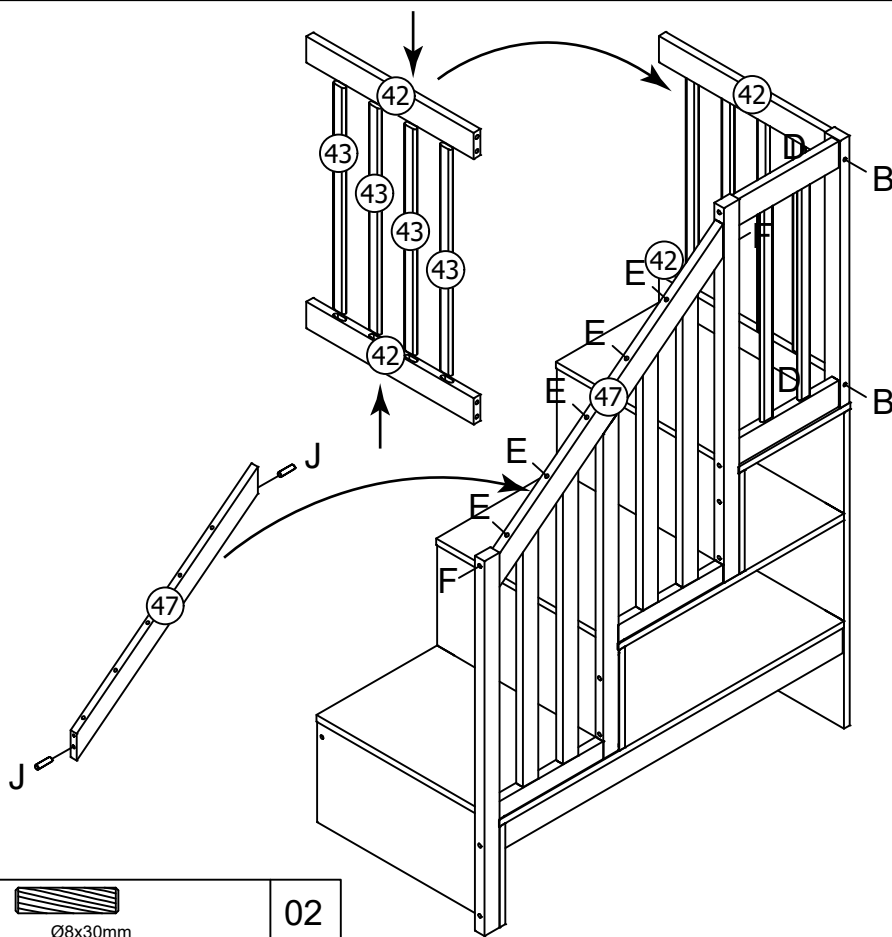

22



23





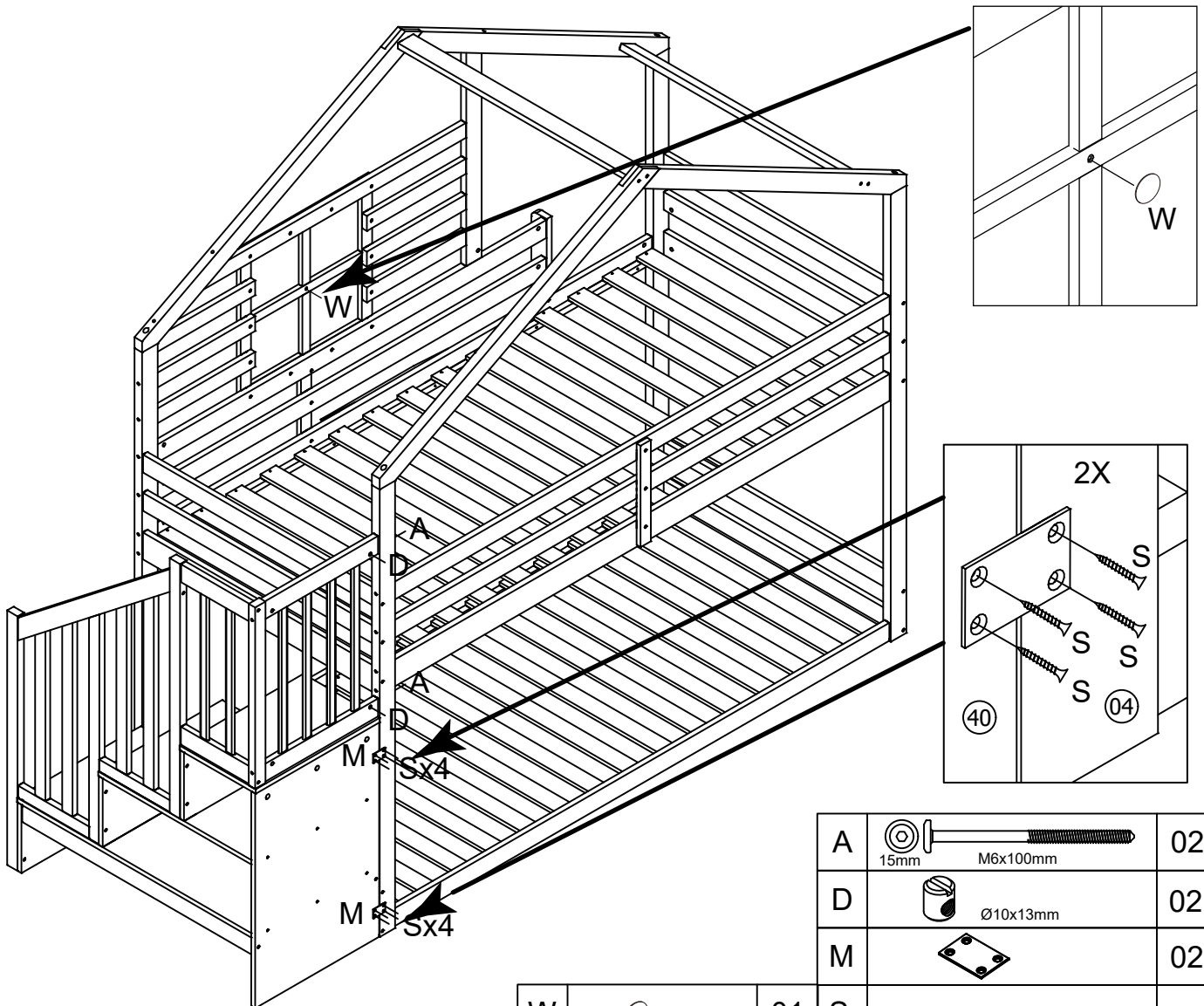

J			02
---	---	---	----

B		15mm M6x90mm	02
D		Ø10x13mm	02
E		15mm Ø6x100mm	05
F		15mm Ø6x70mm	02

24



W		Ø20	01
---	---	-----	----

A		15mm M6x100mm	02
D		Ø10x13mm	02
M			02
S		Ø4x16mm	08

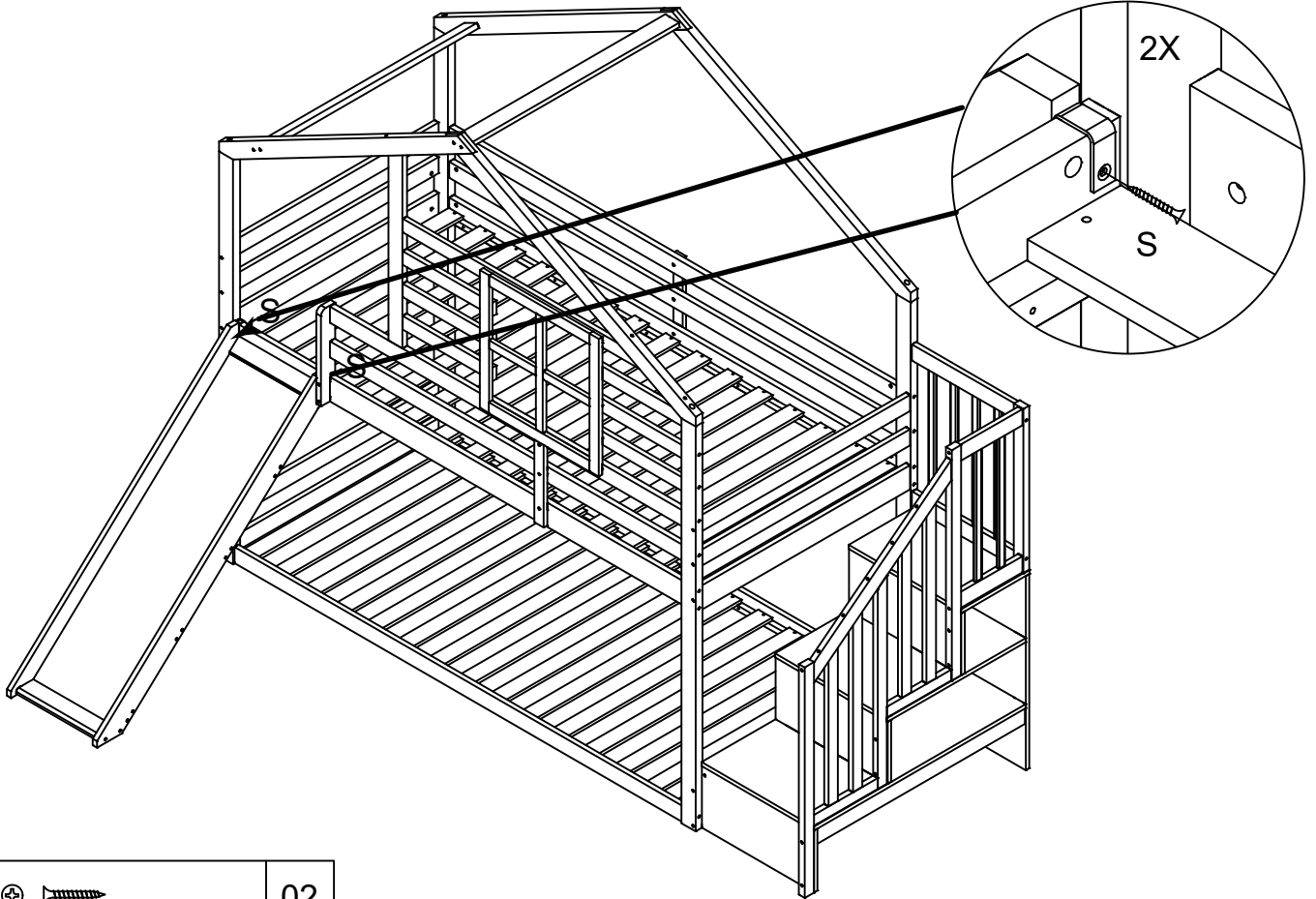

25

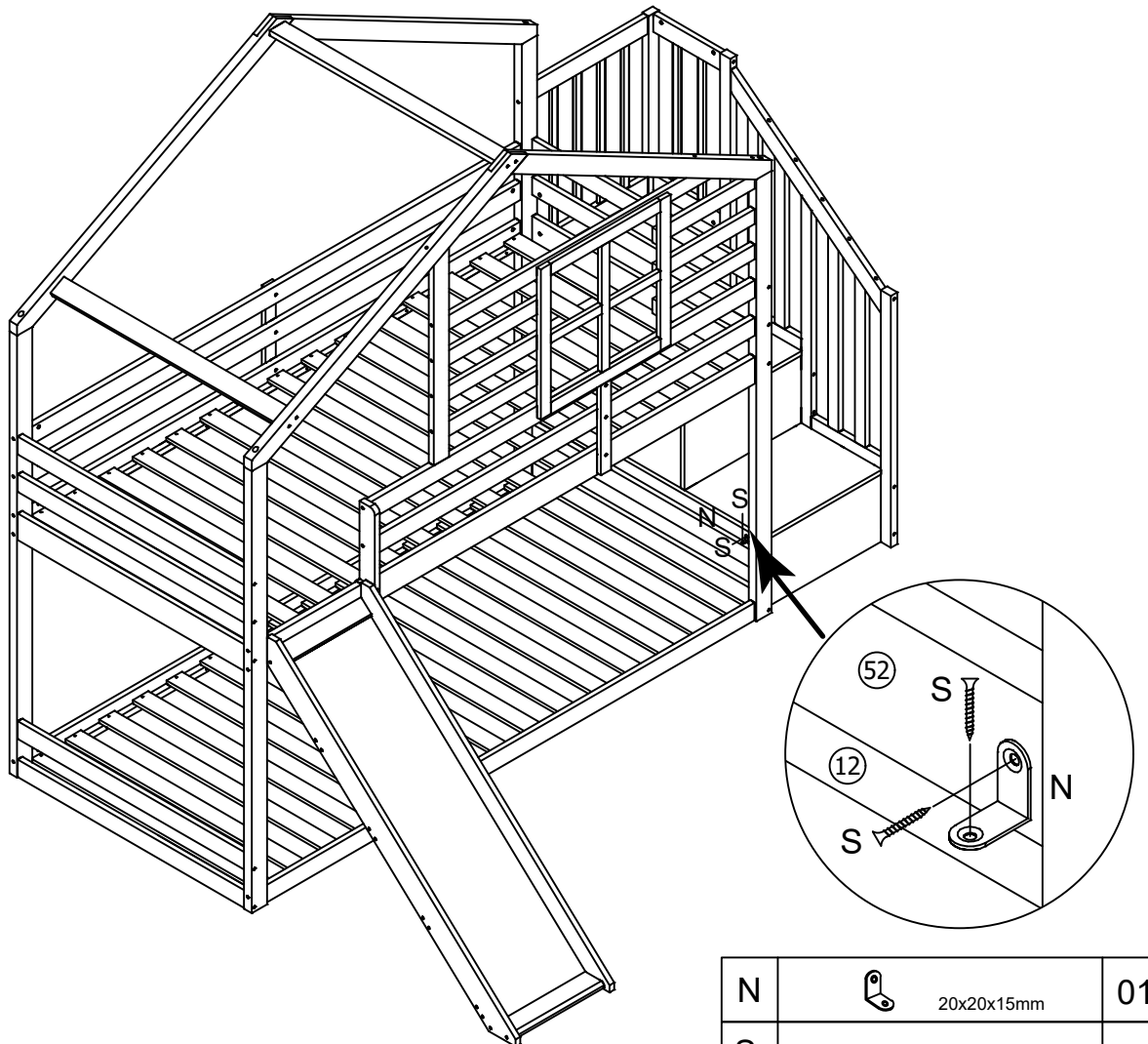

S	 Ø4x16mm	02
---	--	----

26



N	 20x20x15mm	01
S	 Ø4x16mm	02

IMPORTANT-READ CAREFULLY-RETAIN FOR FUTURE REFERENCE

1.All bunk beds and high beds intended to be assembled by someone other than the manufacturer or their representative shall contain assembly instructions including a

1 list of the parts supplied and details of any tools required to assemble the bed.

2.All assembling fastenings should always be tightened properly and the care should be taken that no fittings are loose.

1. 3.The maximum thickness of the mattress should not exceed the marking on the upper bed and the maximum thickness of the mattress should be **10-14cm**.

1. 4.Recommend sizes of the mattress: **L 200 x W 90 x H 10-14cm**

5.The bunk bed or the high bed should not be used if any structural part is broken or missing.

6.Children can strangle in items such as ropes,strings,cords,harnesses and belts attached to or hung on a bunk bed/high bed.

7.WARNING: Children can become trapped between the bed and wall.To avoid risk of serious injury the distance between the top safety barrier and the wall shall not exceed 75mm or shall be more than 230mm.

8.WARNING: High bed and the upper bed of the bunk bed are not suitable for children under 6 years due to the risk of injury from falls.

9.EN 747-1:2024

WICHTIG – SORGFÄLTIG LESEN – ZUM SPÄTEREN NACHSCHLAGEN AUFBEWAHREN

1. Alle Etagenbetten und Hochbetten, die von jemand anderem als dem Hersteller oder seinem Vertreter zusammengebaut werden sollen, müssen eine Montageanleitung enthalten, einschließlich einer Liste der mitgelieferten Teile und Angaben zu allen Werkzeugen, die zum Zusammenbau des Bettes erforderlich sind.

2. Alle Befestigungselemente müssen immer richtig festgezogen sein und es muss darauf geachtet werden, dass keine Beschläge locker sind.

1. 3. Die maximale Dicke der Matratze darf die Markierung auf dem oberen Bett nicht überschreiten und die maximale Dicke der Matratze sollte **10 -14cm** betragen.

1. 4. Empfohlene Matratzengrößen: **L 200 x B 90 x H 10 -14 cm**

5. Das Etagenbett oder das Hochbett darf nicht verwendet werden, wenn ein Bauteil gebrochen ist oder fehlt.

6. **WARNUNG:** Kinder können sich an Gegenständen wie Seilen, Schnüren, Kordeln, Gurten und Gürteln strangulieren, die an einem Etagenbett/Hochbett befestigt oder aufgehängt sind. Achten Sie also darauf.

7. **WARNUNG:** Kinder können zwischen Bett und Wand eingeklemmt werden. Um das Risiko schwerer Verletzungen zu vermeiden, darf der Abstand zwischen der oberen Sicherheitsbarriere und der Wand 75 mm nicht überschreiten oder muss mehr als 230 mm betragen.

8. **WARNUNG:** Das Hochbett und das obere Bett des Etagenbetts sind aufgrund der Verletzungsgefahr durch Stürze nicht für Kinder unter 6 Jahren geeignet.

9. DE 747-1:2024