

MONTAGEANLEITUNG

Artikelnummer: WF289183
(WF289184)

Einzelbett mit Schublade 190x90cm
Einzelbett mit Schublade (200x90cm)

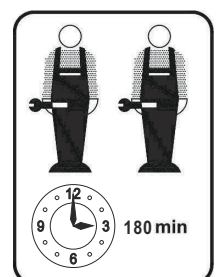
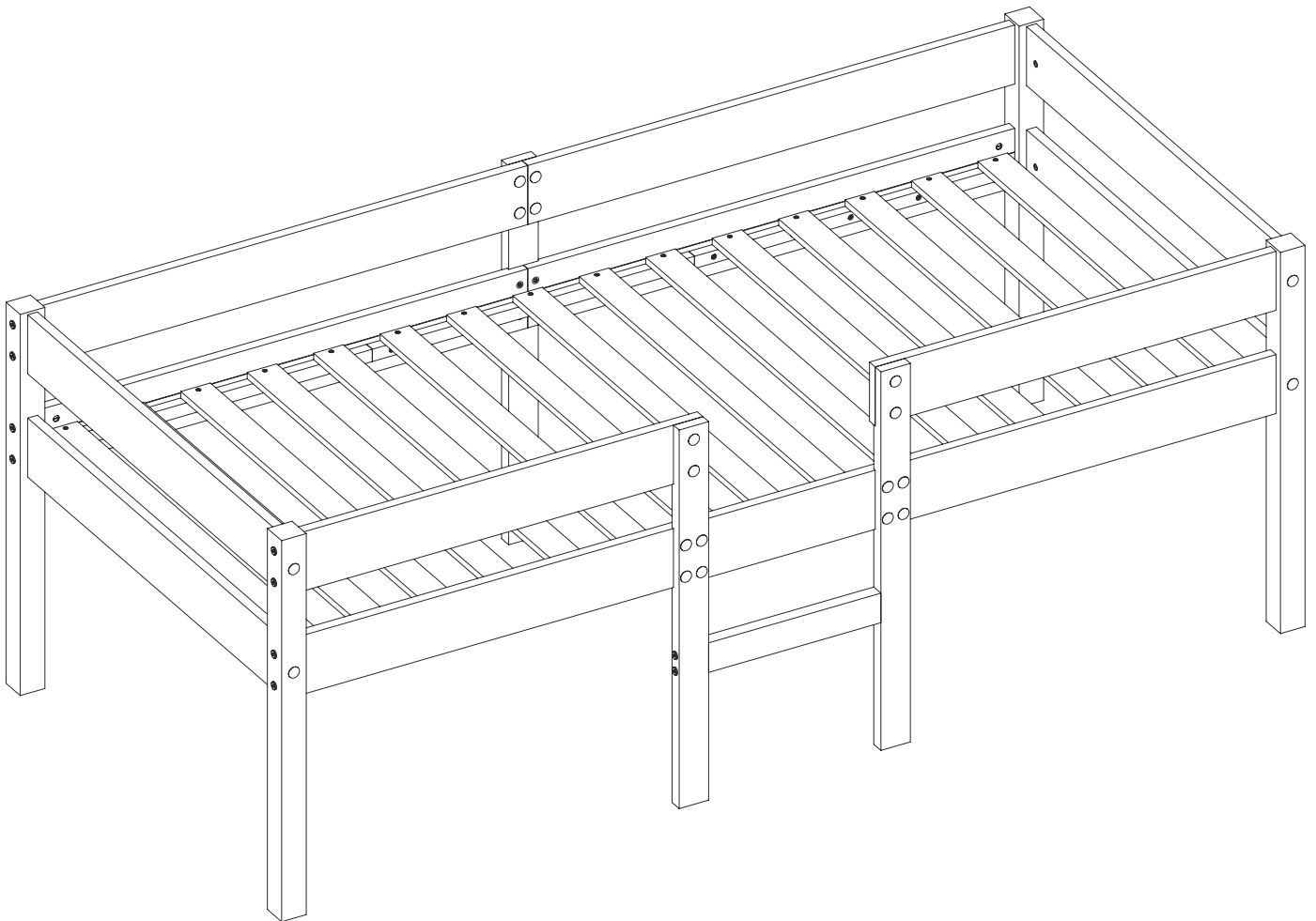

English

IMPORTANT ! KEEP FOR FUTURE REFERENCE : READ CAREFULLY

- To be assembled by an adult. Assembly must be checked by an adult before use
- WARNING ! Keep all screws, small parts and plastic bags out of the reach of children
- Properly identify all parts before assembling
- Never use your item if any of its parts are broken or missing
- Should any problems arise, please contact our After Sales Service
- Manufacturer's instructions shall be followed at all times
- Care: Clean with a soft, dry cloth. In case of larger stains, carefully rub with a slightly damp, non-abrasive sponge
- Avoid the risk of fire by not placing furniture near sources of ignition or hot items
- Do not jump on the bed

Deutsch

WICHTIG ! ZUM SPÄTEREN NACHSCHLAGEN AUFBEWAHREN: SORGFÄLTIG LESEN

- Muss von einem Erwachsenen zusammengebaut werden. Der Zusammenbau muss vor dem Gebrauch von einem Erwachsenen überprüft werden
- WARNUNG! Bewahren Sie alle Schrauben, Kleinteile und Plastikbeutel außerhalb der Reichweite von Kindern auf
- Kennzeichnen Sie vor dem Zusammenbau alle Teile richtig
- Benutzen Sie Ihren Artikel niemals, wenn Teile gebrochen sind oder fehlen
- Sollten Probleme auftreten, wenden Sie sich bitte an unseren Kundendienst
- Die Anweisungen des Herstellers sind stets zu befolgen
- Pflege: Mit einem weichen, trockenen Tuch reinigen. Bei größeren Flecken vorsichtig mit einem leicht feuchten, nicht scheuernden Schwamm abreiben. nicht scheuernden Schwamm
- Vermeiden Sie die Gefahr eines Brandes, indem Sie die Möbel nicht in der Nähe von Zündquellen oder heißen Gegenständen aufstellen
- Nicht auf das Bett springen

Français

IMPORTANT ! CONSERVER POUR RÉFÉRENCE ULTÉRIEURE : LIRE ATTENTIVEMENT

- Le montage doit être effectué par un adulte. Le montage doit être vérifié par un adulte avant Utilisation
- ATTENTION ! Tenir les vis, les petites pièces et les sachets en plastique hors de portée des enfants
- Identifiez correctement toutes les pièces avant de les assembler
- N'utilisez jamais votre article si l'une de ses pièces est cassée ou manquante
- En cas de problème, veuillez contacter notre service après-vente
- Les instructions du fabricant doivent être respectées à tout moment
- Entretien : nettoyer avec un chiffon doux et sec. En cas de taches plus importantes, frotter soigneusement avec une éponge non abrasive légèrement humide. légèrement humide et non Abrasive
- Évitez les risques d'incendie en ne plaçant pas les meubles à proximité de sources d'inflammation ou d'objets chauds
- Ne pas sauter sur le lit

Italiano

IMPORTANTE! CONSERVARE PER RIFERIMENTO FUTURO: LEGGERE ATTENTAMENTE

- Deve essere assemblato da un adulto. L'assemblaggio deve essere controllato da un adulto prima dell'uso
- **ATTENZIONE!** Tenere tutte le viti, le piccole parti e i sacchetti di plastica fuori dalla portata dei bambini
- Identificare correttamente tutte le parti prima dell'assemblaggio
- Non utilizzare mai l'articolo se alcune parti sono rotte o mancanti
- In caso di problemi, si prega di contattare il nostro Servizio Post Vendita
- Le istruzioni del produttore devono essere sempre seguite
- Cura: Pulire con un panno morbido e asciutto. In caso di macchie più estese, strofinare accuratamente con una spugna leggermente umida e nonspugna leggermente umida e non abrasiva
- Evitare il rischio di incendio, non collocando i mobili vicino a fonti di accensione o a oggetti caldi
- Non saltare sul letto

Español

¡ IMPORTANTE ! CONSERVELO PARA FUTURAS CONSULTAS: LEA ATENTAMENTE

- Debe ser montado por un adulto. El montaje debe ser comprobado por un adulto antes del uso
- ADVERTENCIA Mantenga todos los tornillos, piezas pequeñas y bolsas de plástico fuera del alcance de los niños.
- Identifique correctamente todas las piezas antes de montarlas
 - Nunca utilice su artículo si alguna de sus piezas está rota o falta
 - Si surge algún problema, póngase en contacto con nuestro Servicio Postventa
 - Las instrucciones del fabricante deben seguirse en todo momento
 - Cuidado: Limpiar con un paño suave y seco. En caso de manchas más grandes, frote cuidadosamente con una esponja no abrasiva ligeramente humedecida.
 - Evite el riesgo de incendio no colocando los muebles cerca de fuentes de ignición u objetos calientes.
 - No saltar sobre la cama.

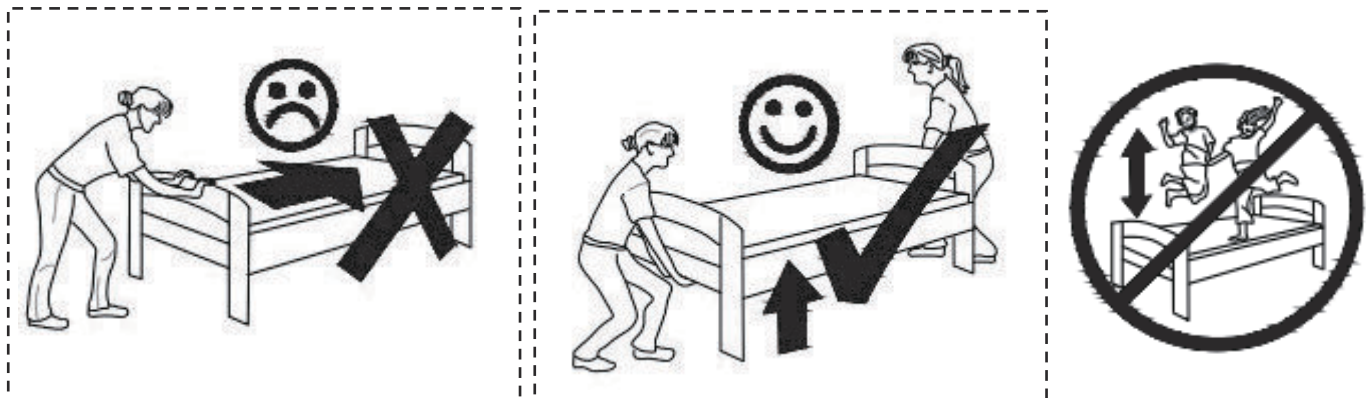



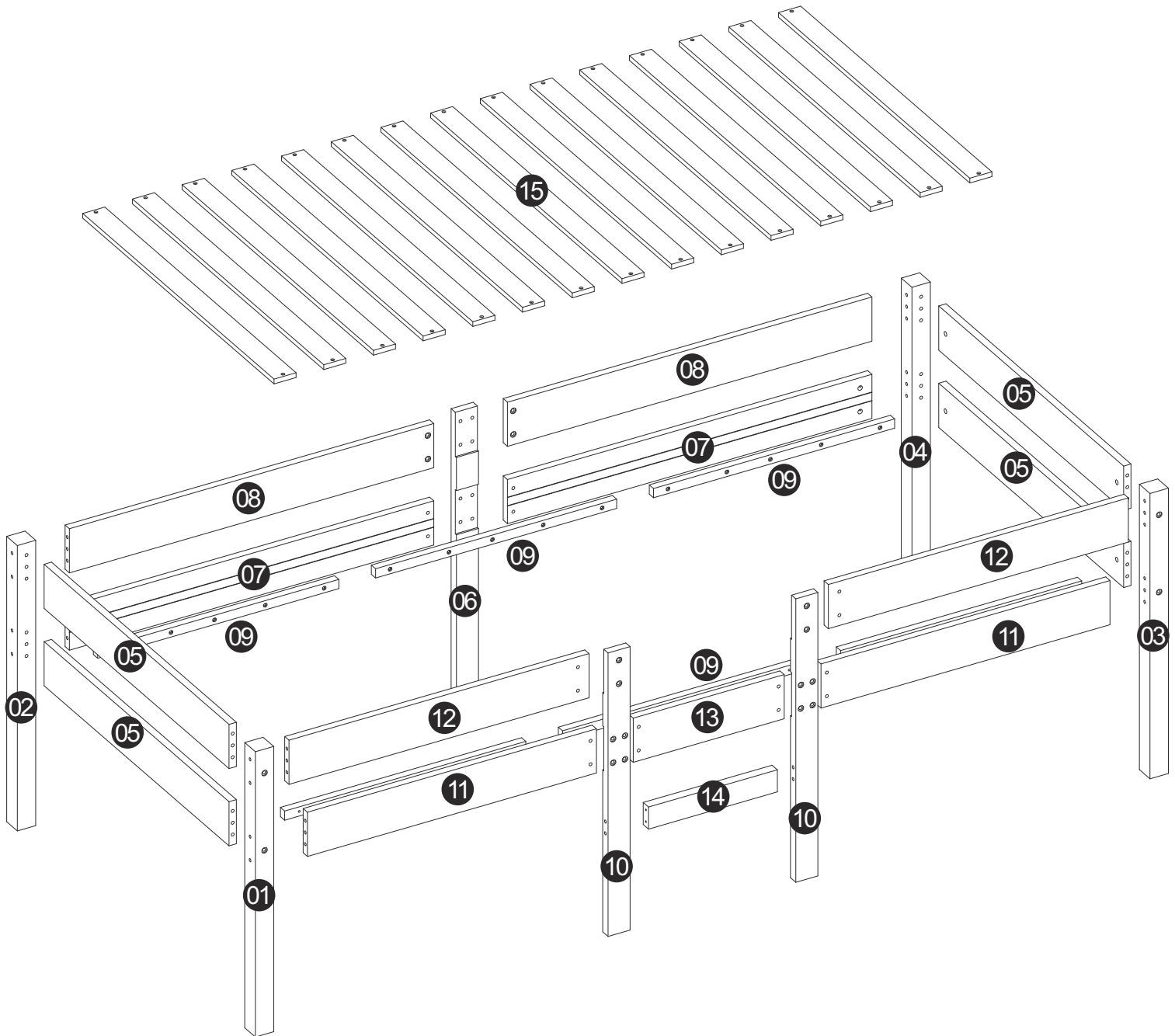



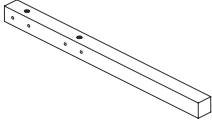
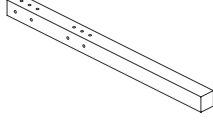
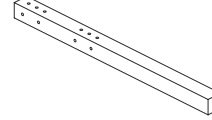
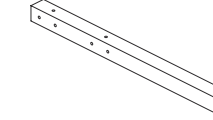
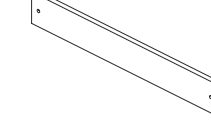
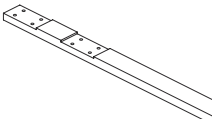
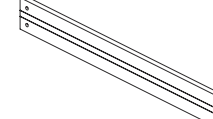
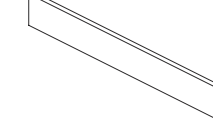
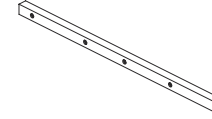
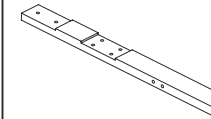
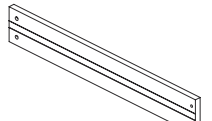
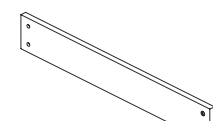
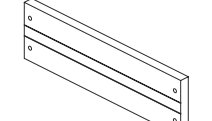
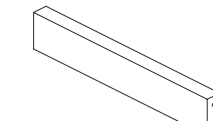
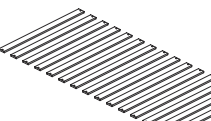

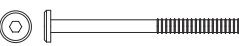

Stückliste



WF289183(WF289184)

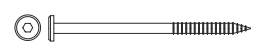

01 x1 	02 x1 	03 x1 	04 x1 	05 x4 
06 x1 	07 x2 	08 x2 	09 x6 	10 x2 
11 x2 	12 x2 	13 x1 	14 x1 	15 x1 

Hardware-Liste WF289183(WF289184)

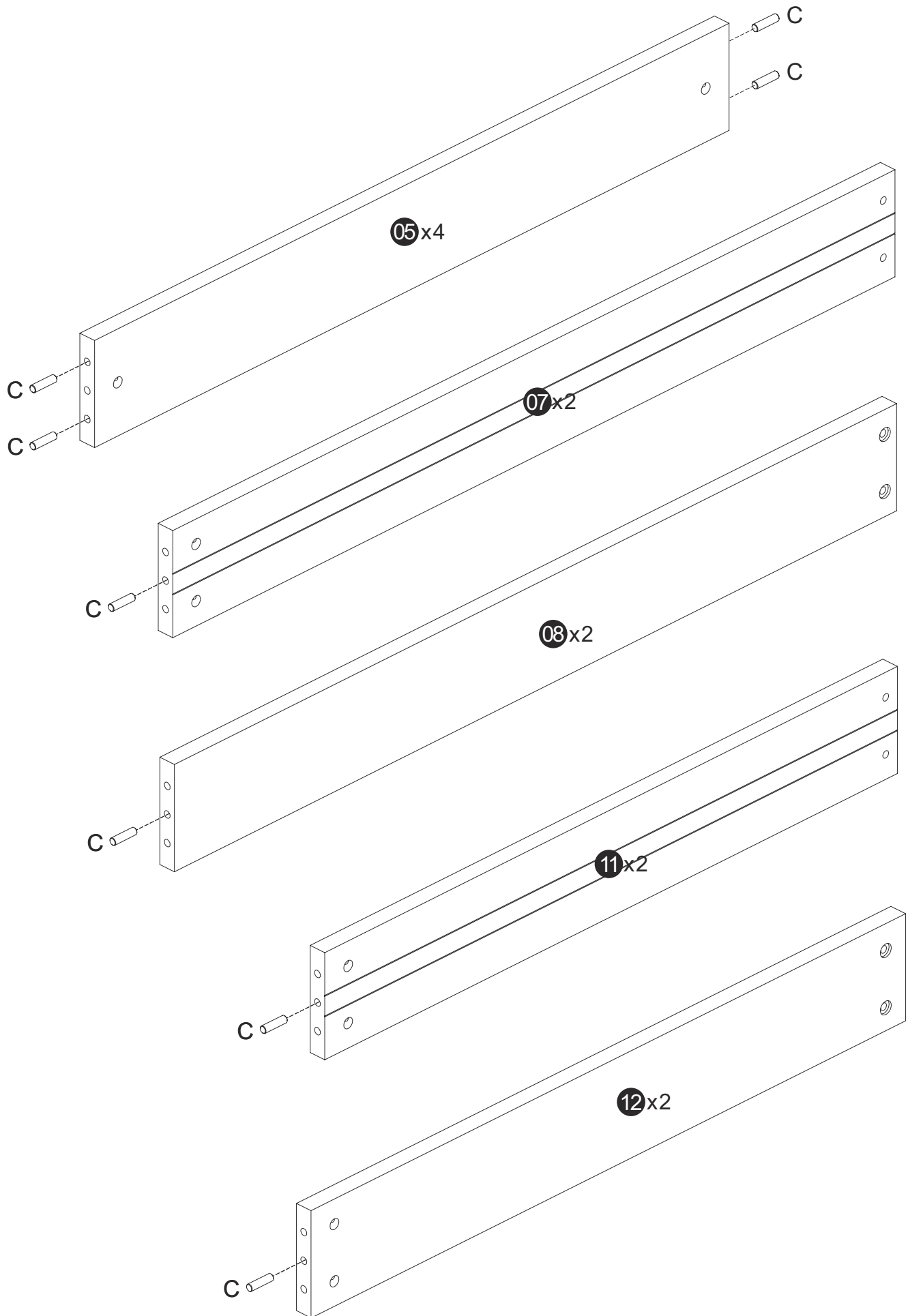
A x24  M6x90	B x24 	C x24  Φ8x30	D x20  M6x25	E x20 
F x60  Φ4x30	G x4  Φ6x100	H x16 	J x8 	K x2 



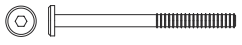

Schritt 2

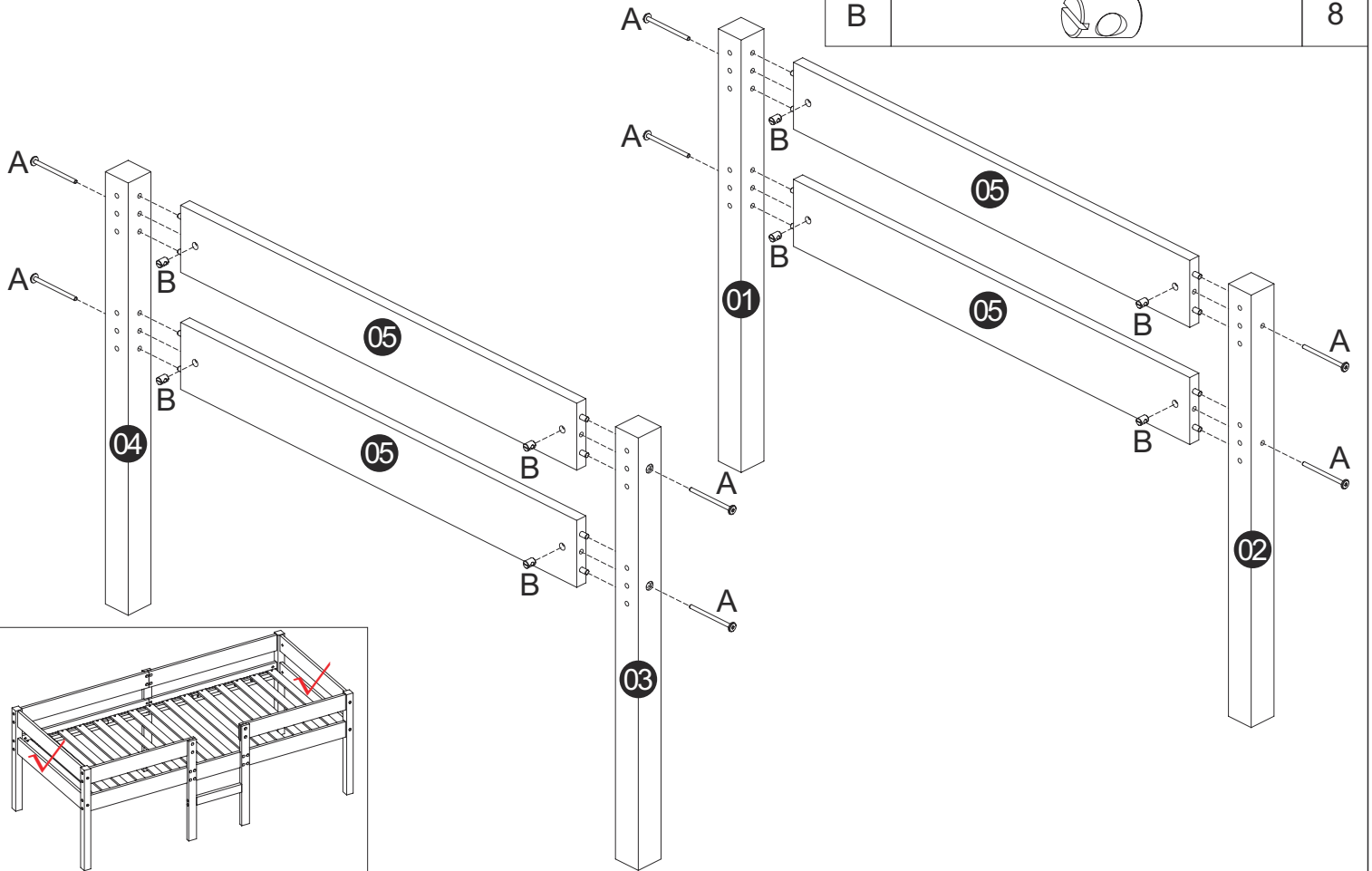
A	 M6x90	8
B		8



Schritt 3

D	 M6x25	8
E		8

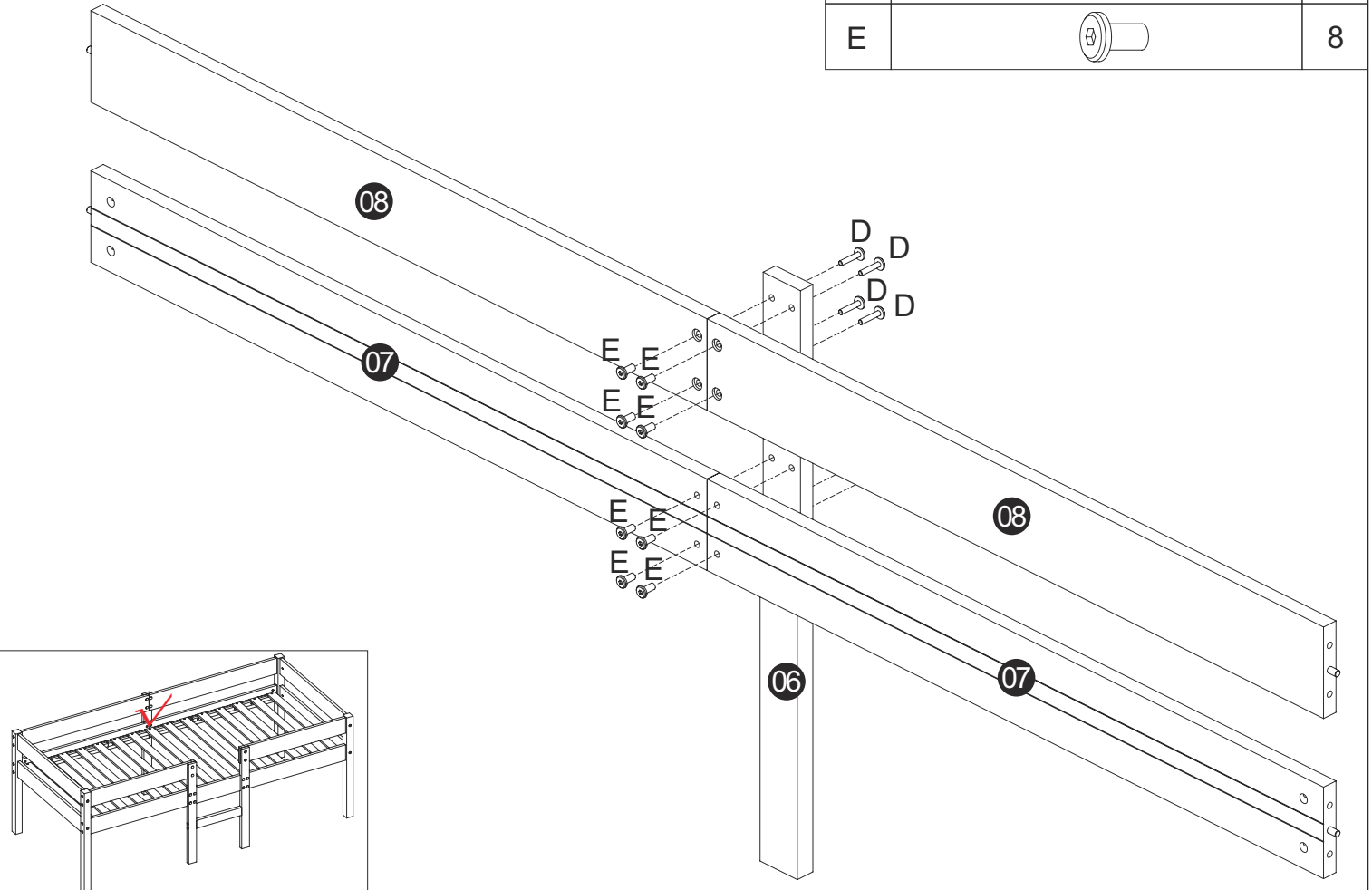

Schritt 4

F



Φ4x30

15

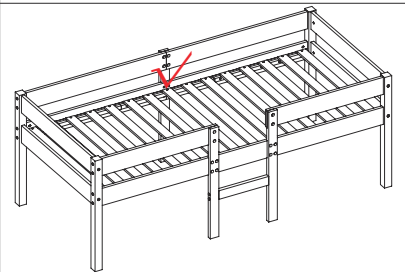
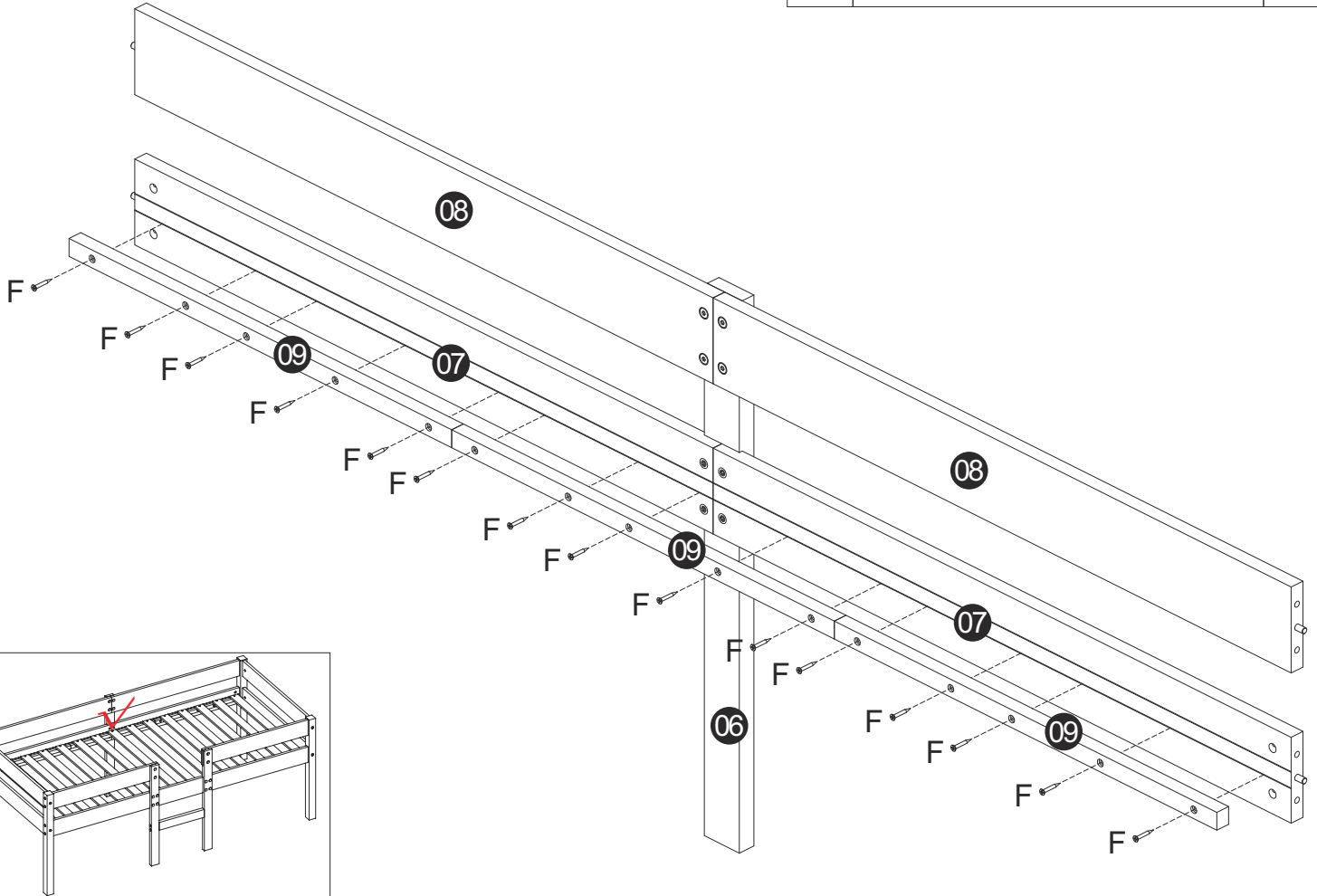

Schritt 5

D



M6x25

4

E



4

G



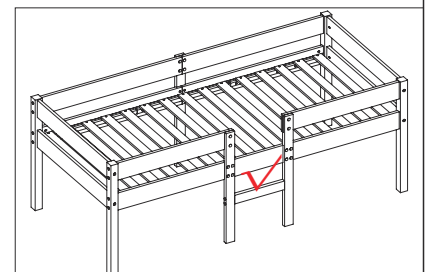
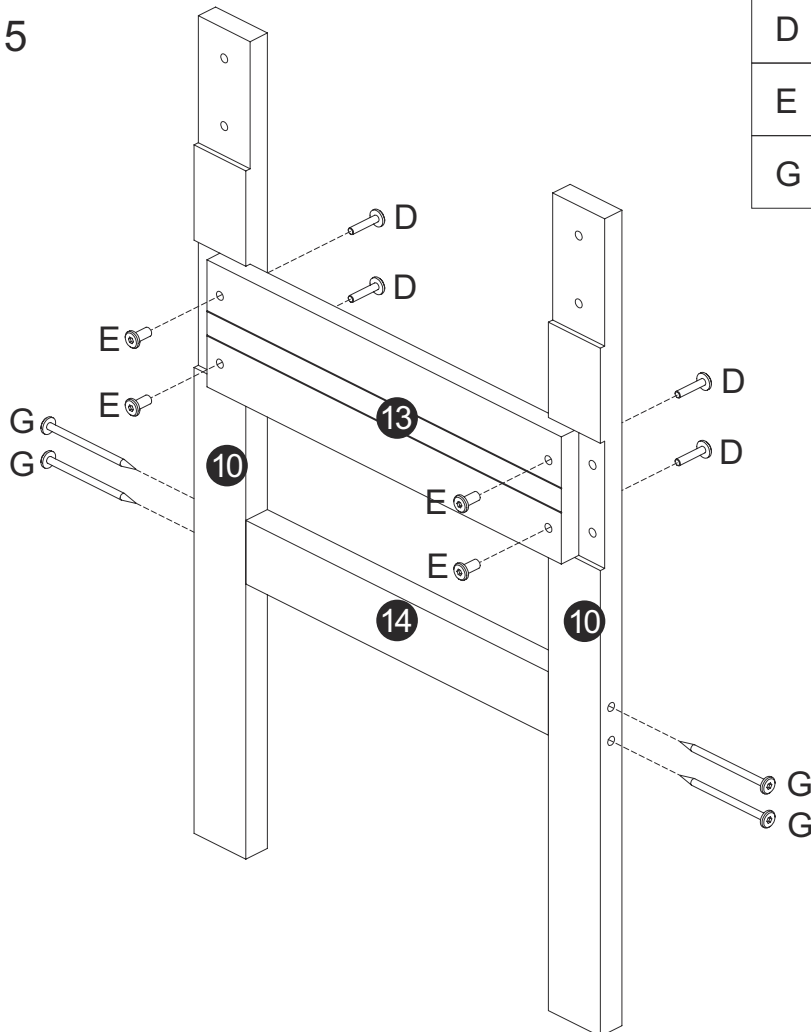

Φ6x100

4

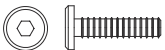

Schritt 6

D	 M6x25	8
E		8

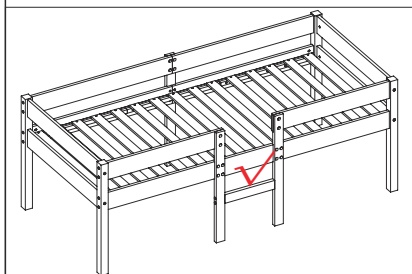
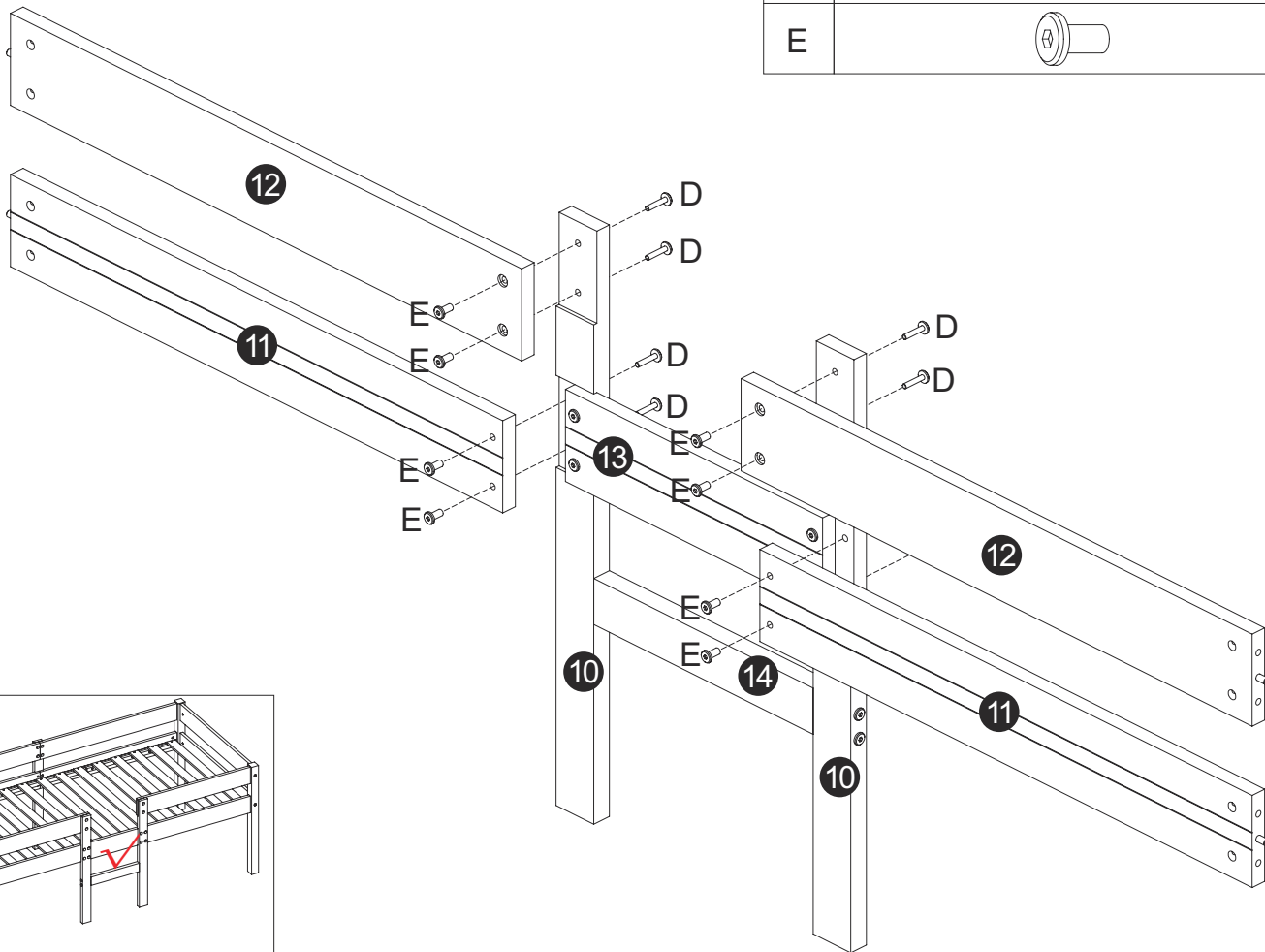

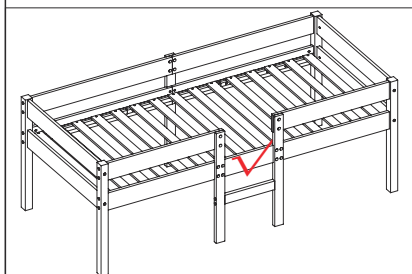
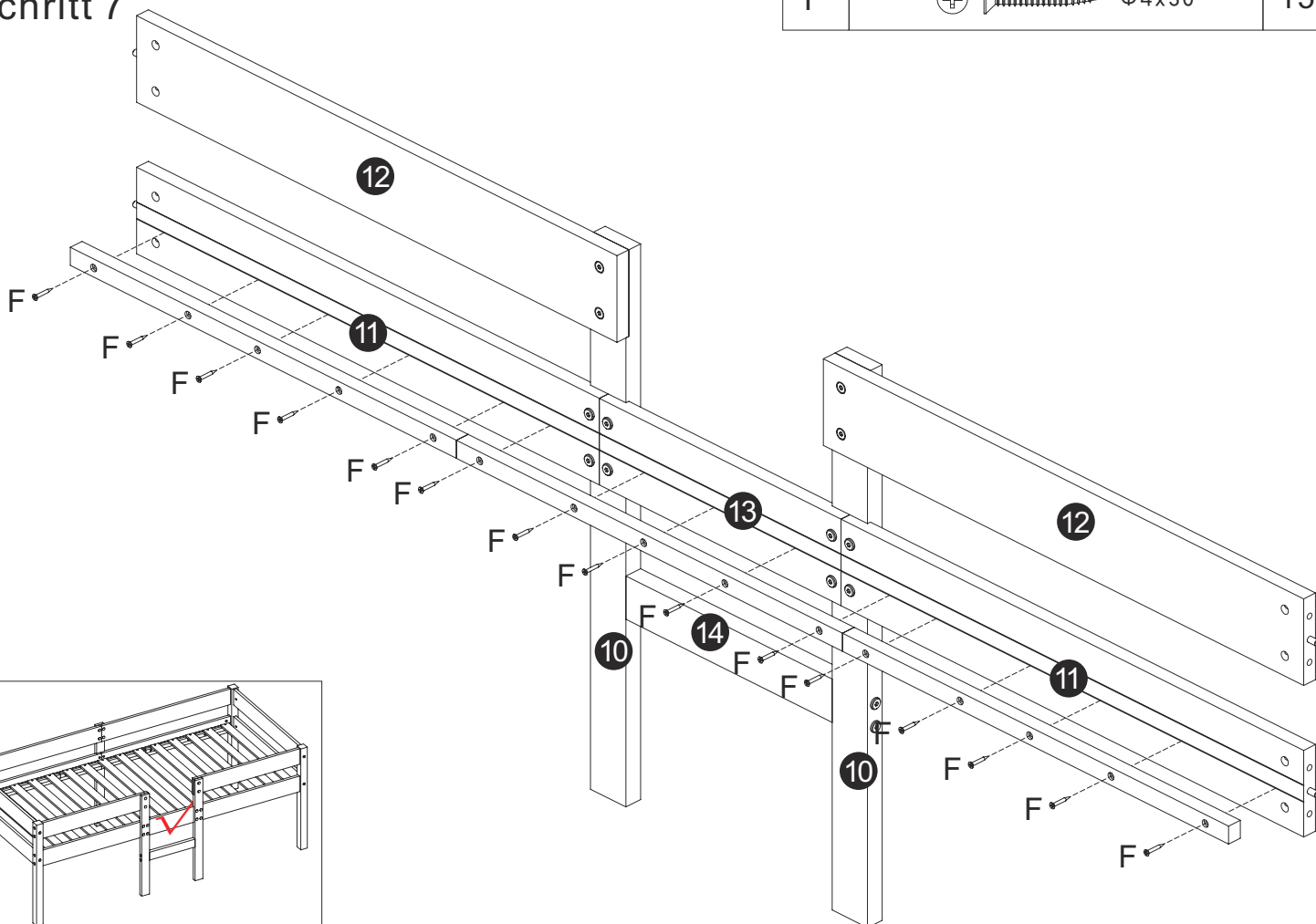

Schritt 7

F	 $\Phi 4 \times 30$	15
---	--	----



Schritt 8

A	 M6x90	16
B		16

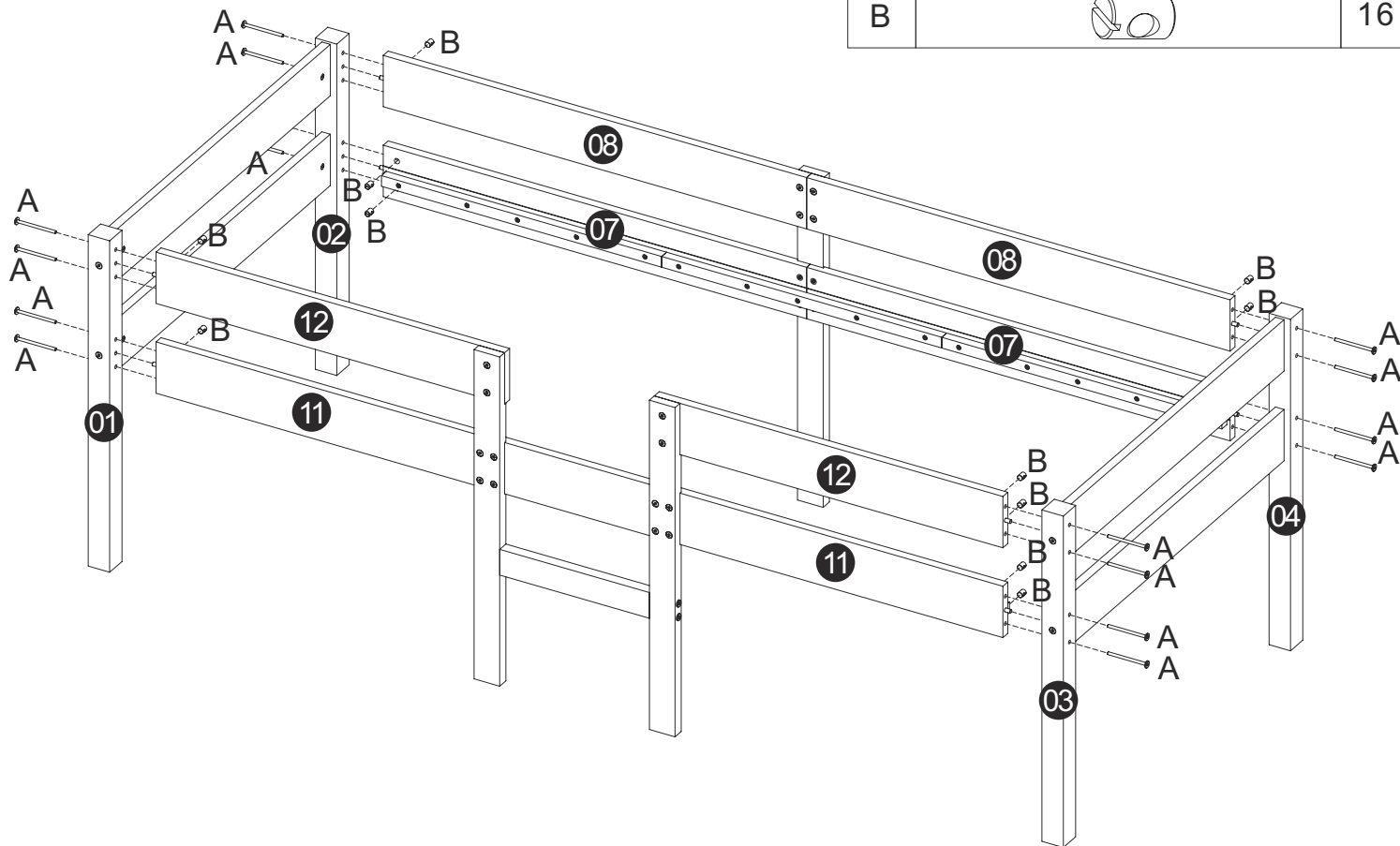

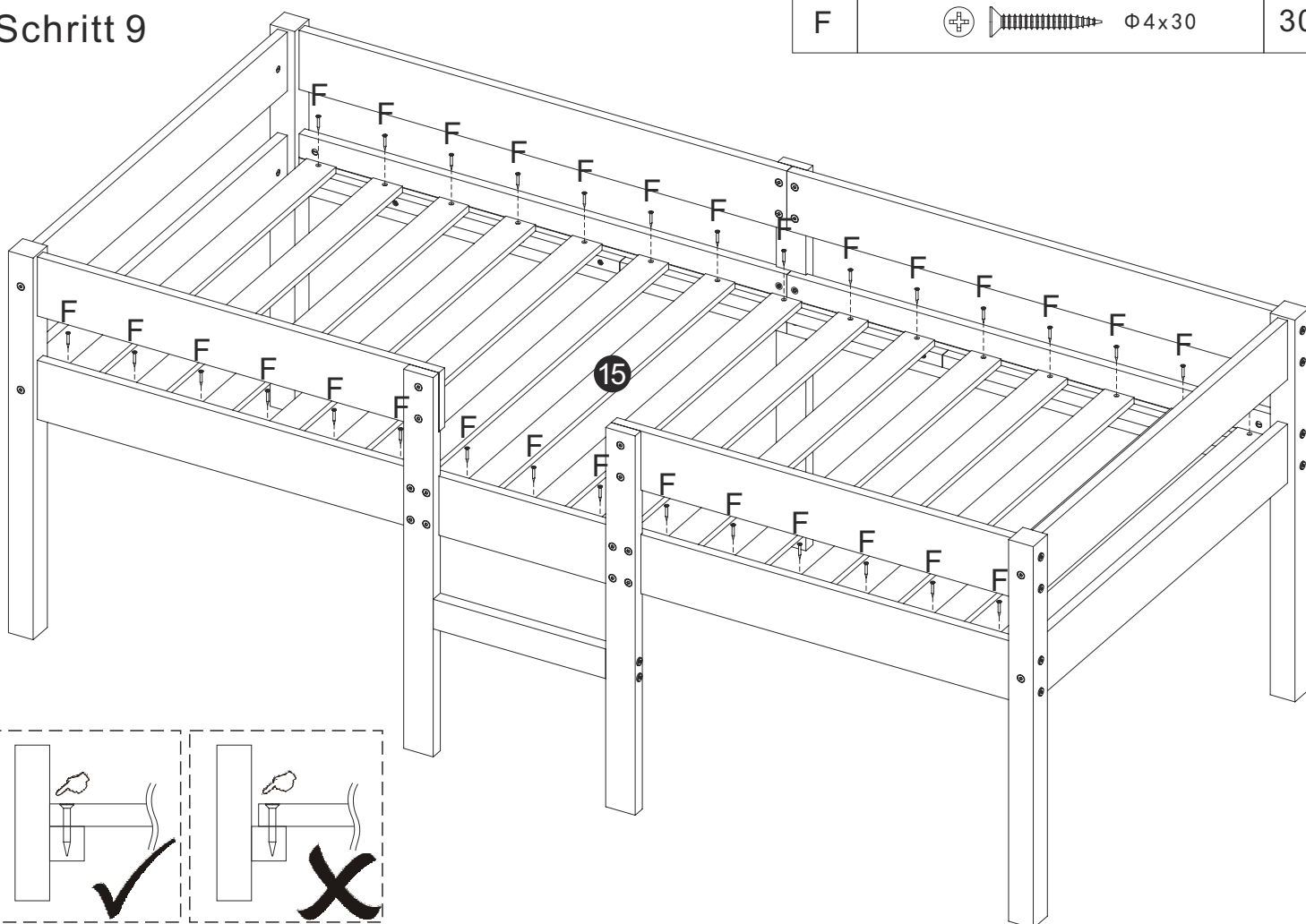

Schritt 9

F	 $\Phi 4 \times 30$	30
---	--	----



Schritt 10

H		16
J		8

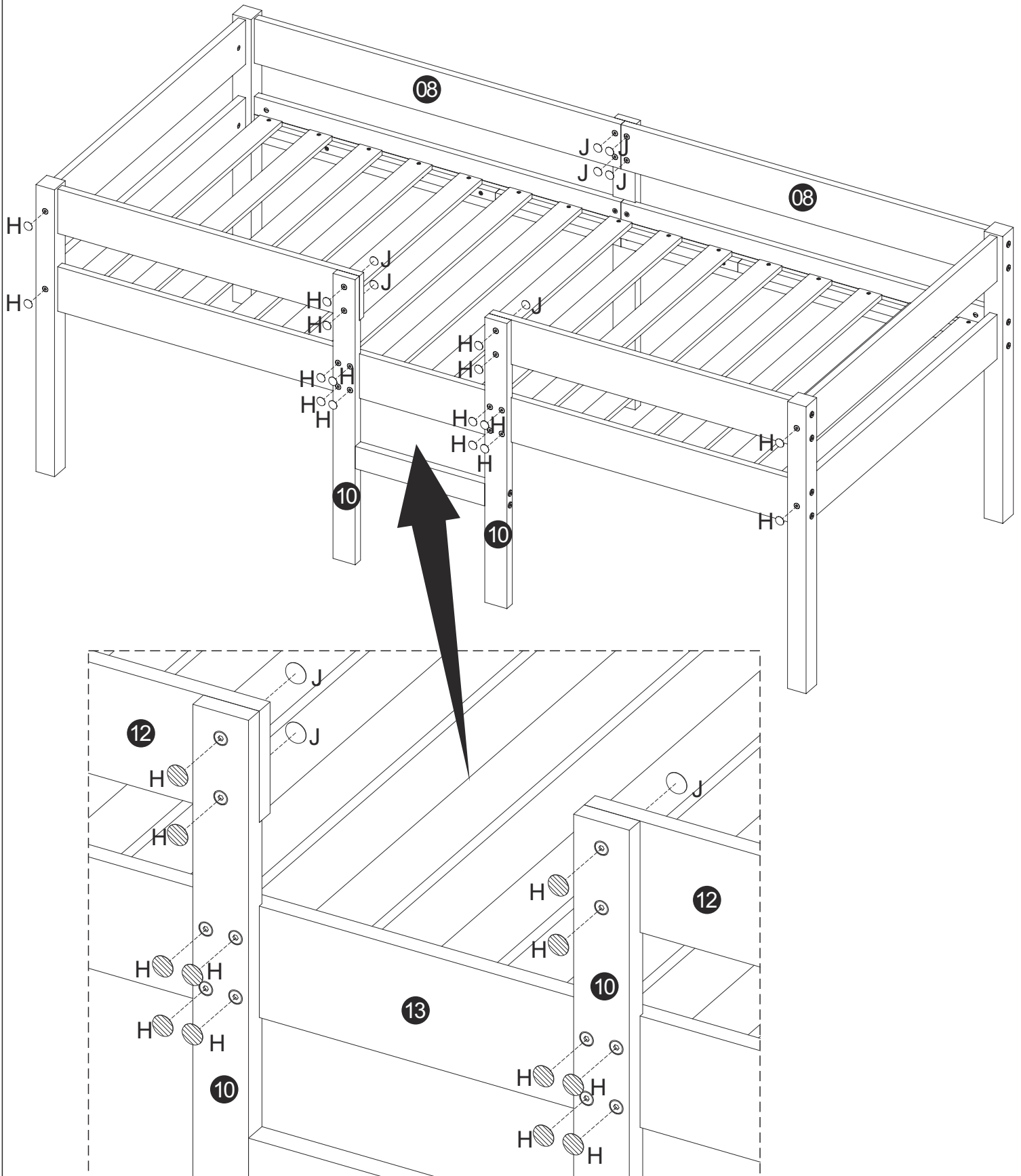

MONTAGEANLEITUNG

Artikelnummer: WF289185AAA

Einzelbett mit Schublade-2 Schubladen

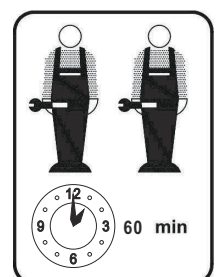
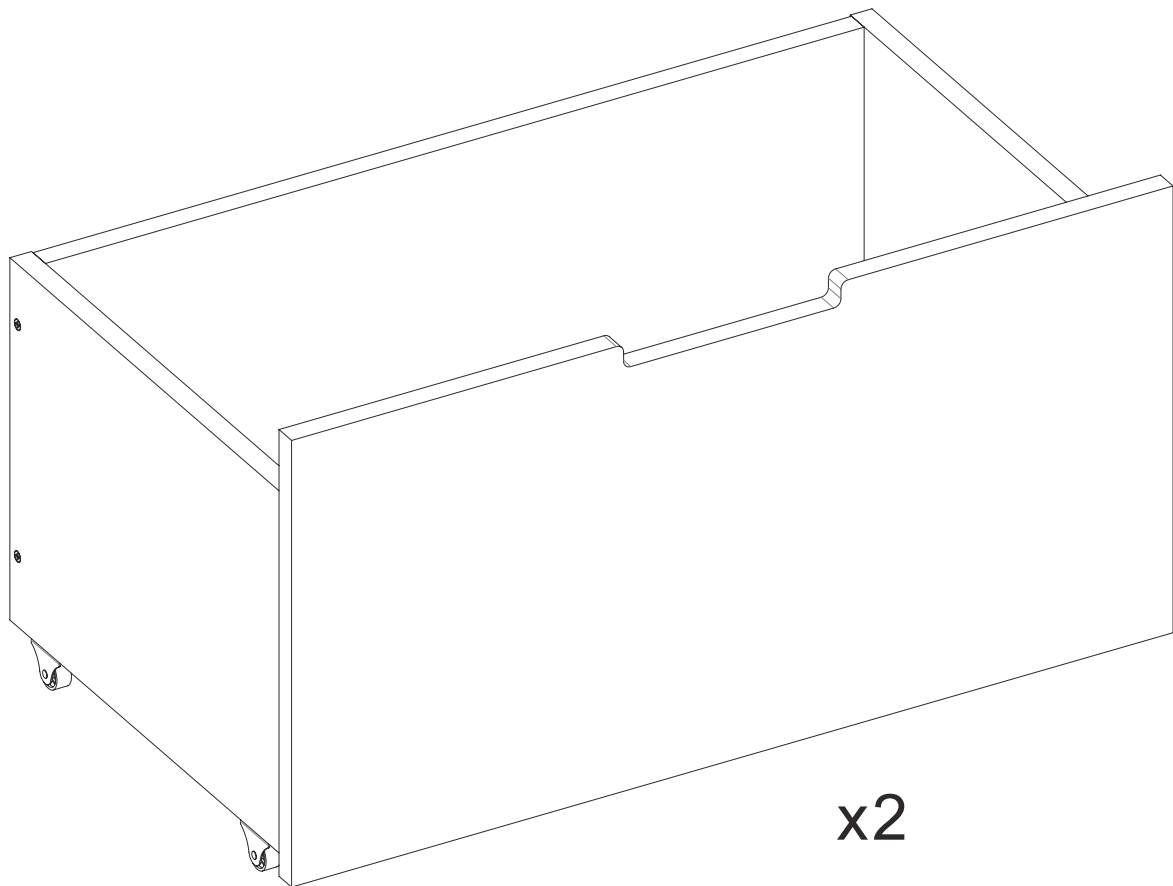

! SICHERHEITSWARNUNGEN !





1. Wir danken Ihnen für den einkauf! Wir haben daran gearbeitet, Ihnen Produkte mit hoher Qualität anzubieten. Im seltenen Fall, dass Ihr Produkt beschädigt ist, Teile fehlen oder Sie auf Probleme bei der Montage stoßen, wenden Sie sich damit bitte an unseren Kundendienst, um die fehlendes Teile, die Montagevorschläge und die Garantieansprüche zu erreichen. Wir werden Ihnen die beste Lösung schnellstmöglich anbieten. Um Ihr Problem schneller zu lösen bitte stellen Sie uns einige Bilder zur Verfügung, die das Produktproblem deutlich widerspiegeln können. Vielen Dank!
2. Setzen Sie die Schrauben vor Abschluss der Montage in die Löcher ein, ziehen Sie die Schrauben fest, aber nicht zu 100% festziehen.70% sind in Ordnung. Schließlich, wenn es kein Problem mit der Montage gibt, dann ziehen Sie alle Schrauben zu 100% fest. Wenn Sie diese Probleme auftreten , Z.B. falls die Löcher nicht ausgerichtet werden können oder einige Teile nicht installiert warden können, überprüfen Sie bitte die Schrauben und bitte stellen Sie die Dichtheit der Schrauben ein.
3. 2 Personen werden empfohlen, die Installation durchzuführen.

! SAFETY WARNINGS !

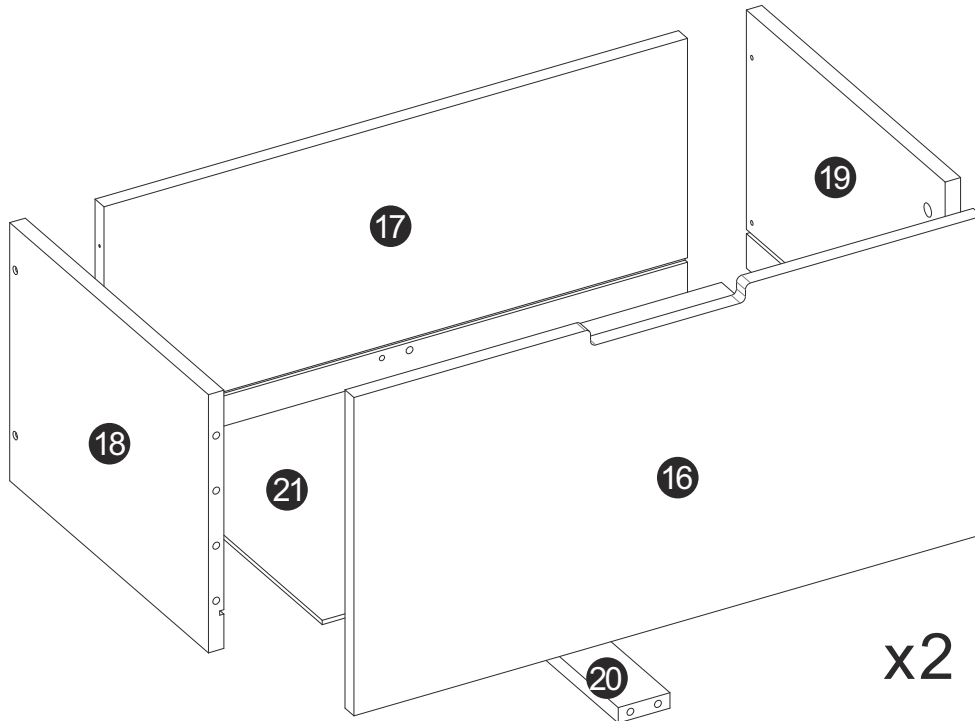
1. Please read the instructions fully before assembly. These instructions include important information which could ensure correct assembly. We have been working on providing high quality products for you. However, in the rare instance that your product is defective, missing parts or there are some issues, please don't hesitate to contact our customer service to submit parts requirements, assembly suggestion, or warranty claims, and we will give the best solution as soon as possible. If necessary, we need you to provide some more clear pictures of the issue.
2. Insert the screws in holes and tighten the screws, but not too tight, 70% is ok, finally tighten all the screws. If some issues happened that some screws can not target to the hole or some parts are difficult to install, please adjust the tightness of the screws.
3. 2 people are recommended to finish.

Stückliste

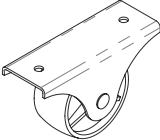
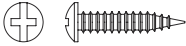

<p>C x12</p> 	<p>L x12</p> 	<p>M x12</p> 	<p>N x8</p>  <p>Φ 4x40</p>
<p>P x8</p> 	<p>Q x16</p>  <p>Φ 3.5x16</p>		

Wichtiger Hinweis:

Bestätigen Sie bitte alle Komponenten und Schrauben vor der Montage. Bitte wenden Sie sich an uns, falls einige Teile oder Schrauben im Paket fehlt sind.

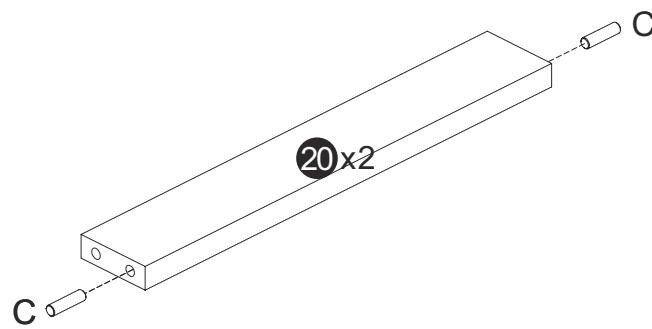
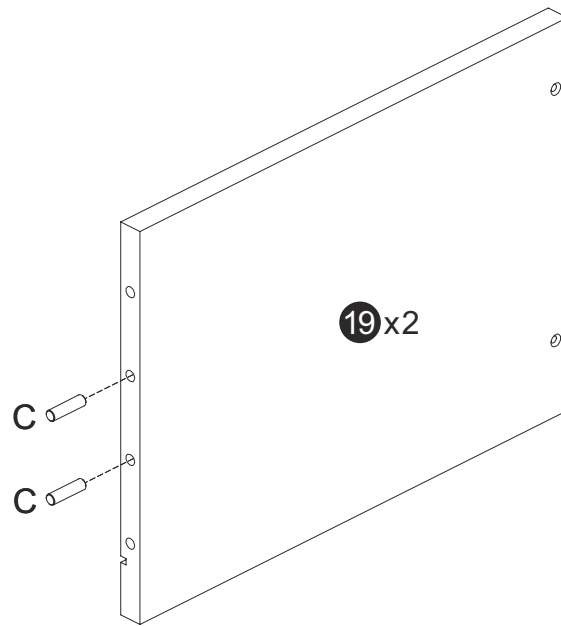
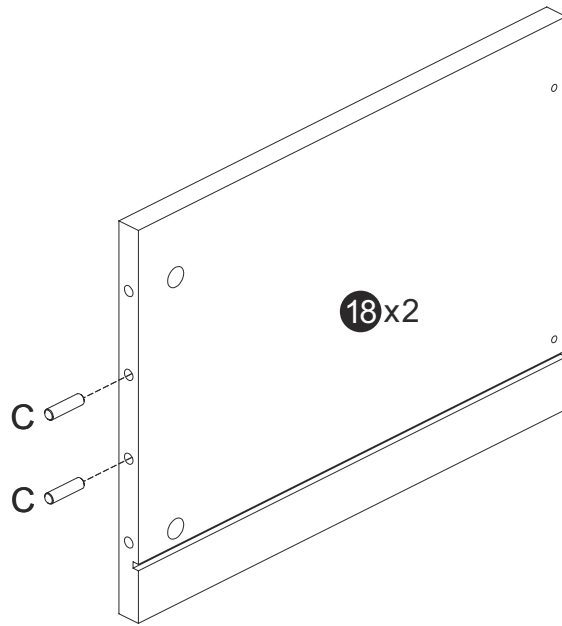

Schritt 12

L

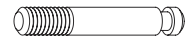

12

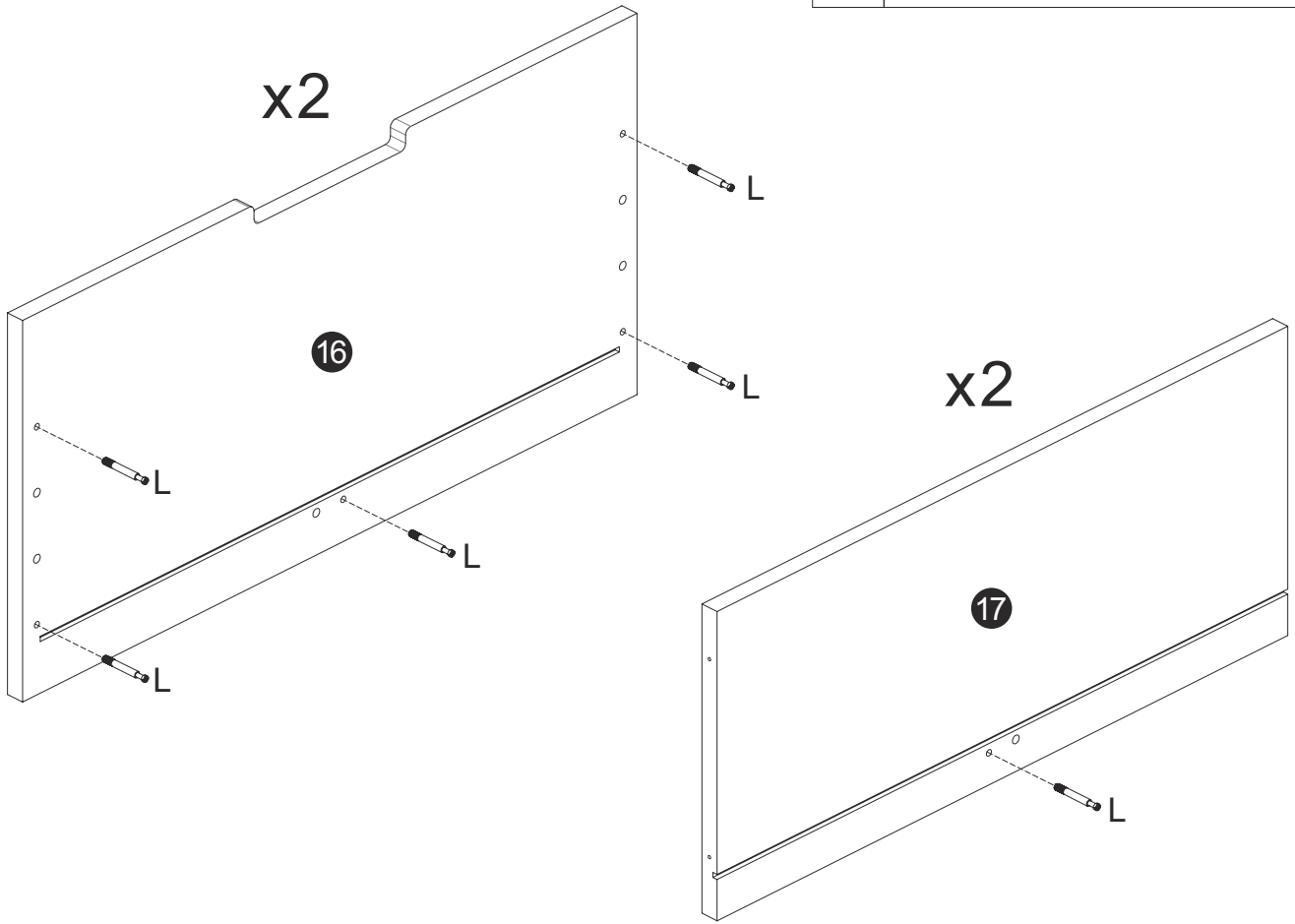

Schritt 13

N



8

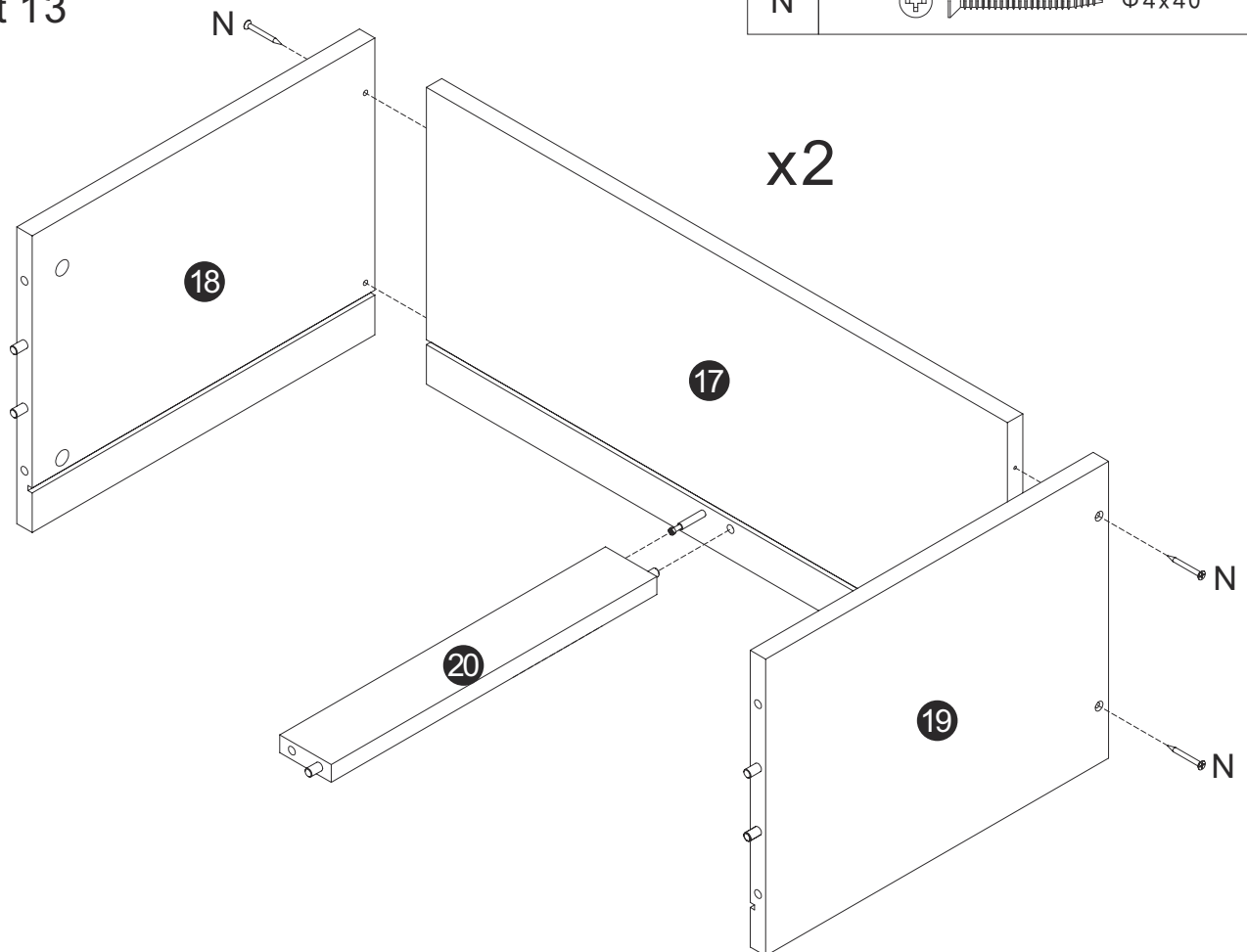

Schritt 14

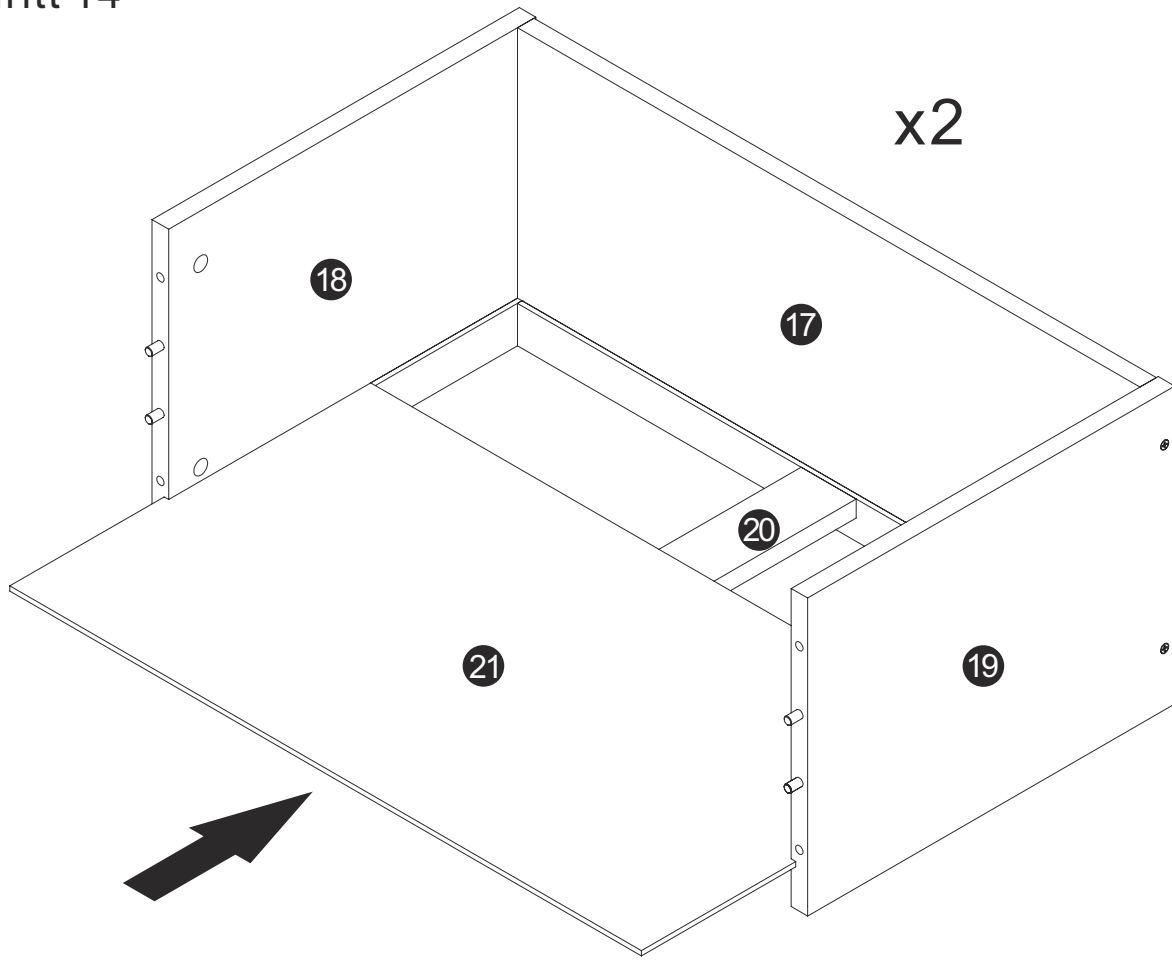

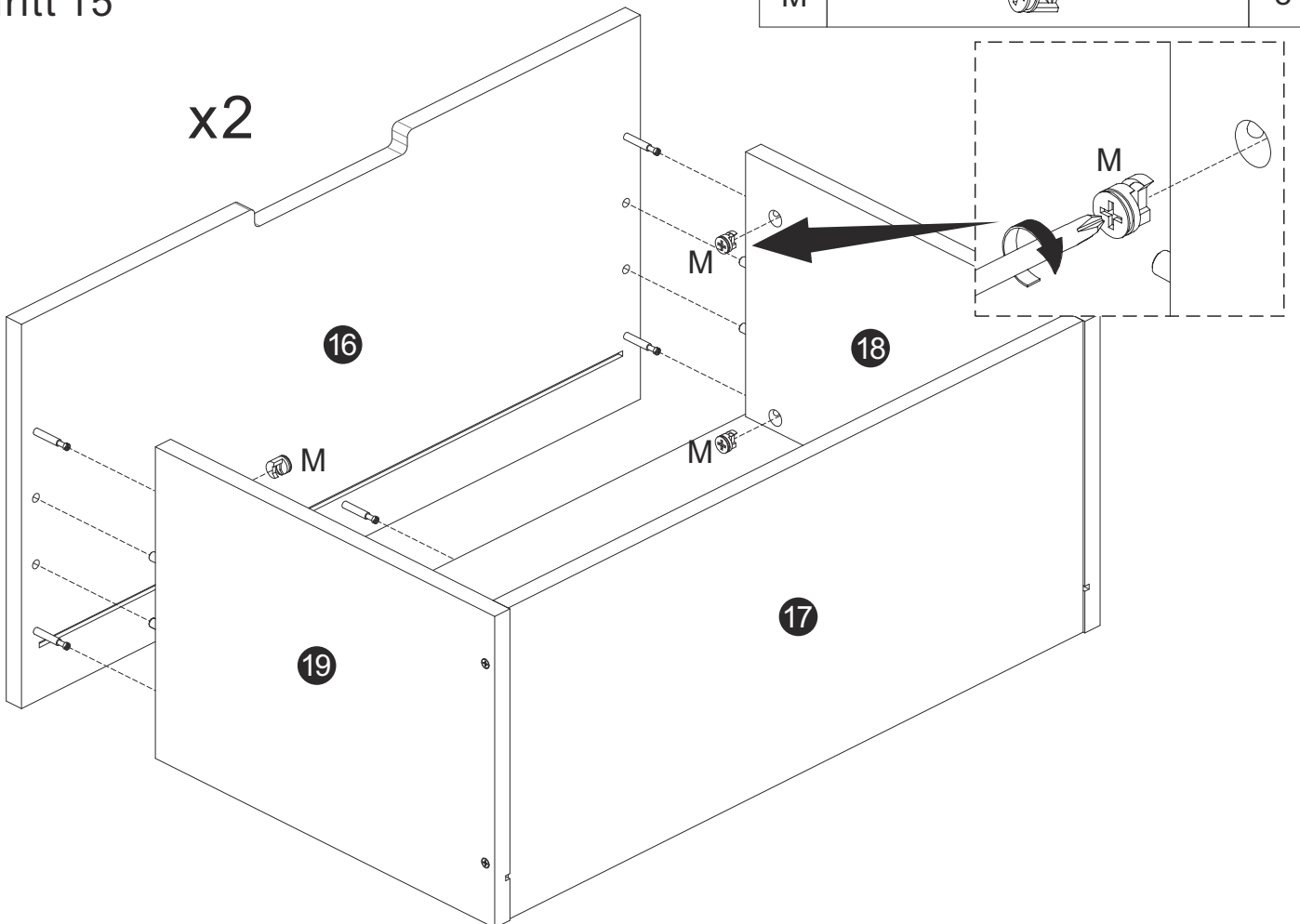

Schritt 15



Schritt 16

x2

M		4
P		8
Q	 $\Phi 3.5 \times 16$	16

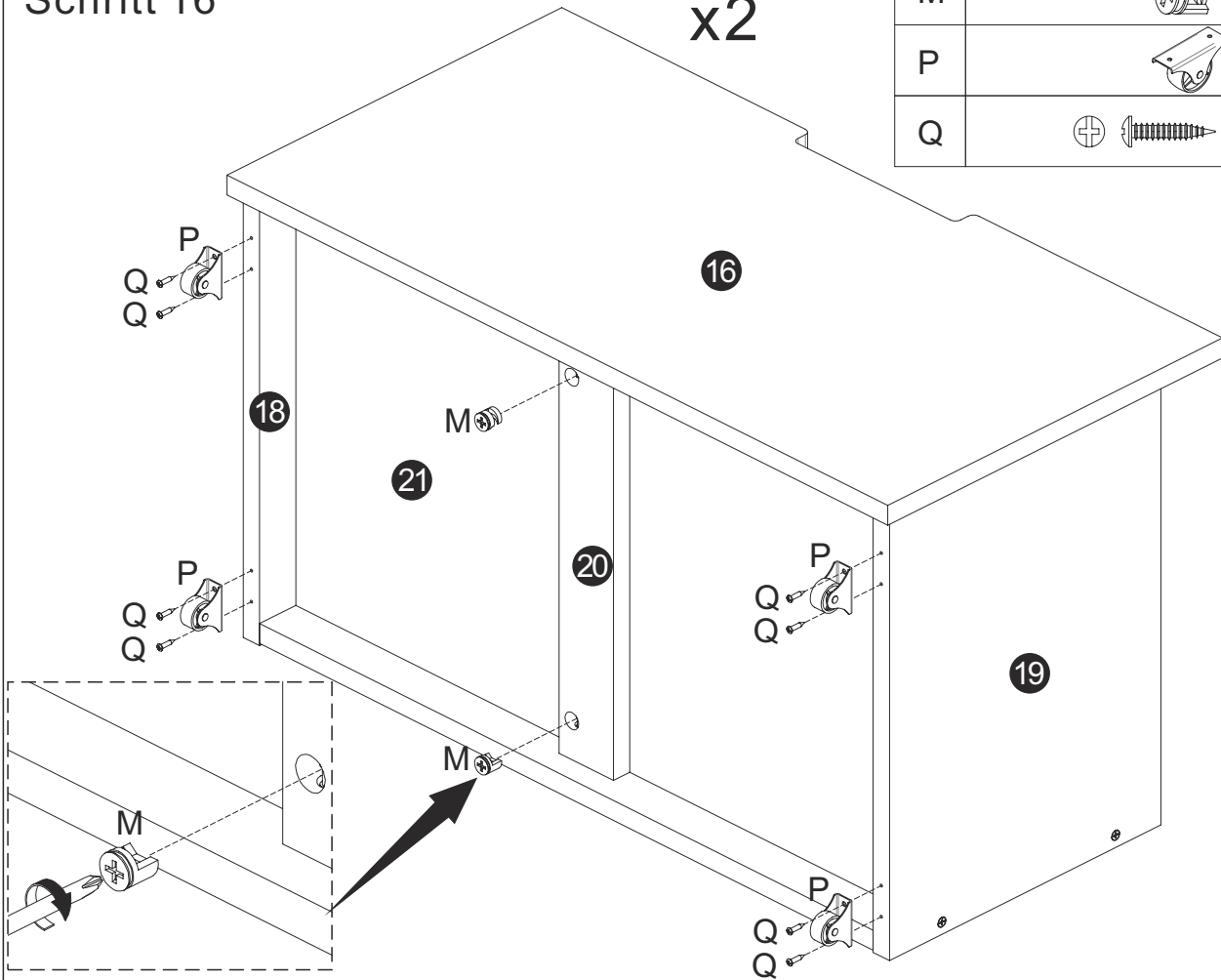

Schritt 17

