

Installation sanleitung Installation Instruction Instruction d'installation

SKU:N636P223264/N636P223265

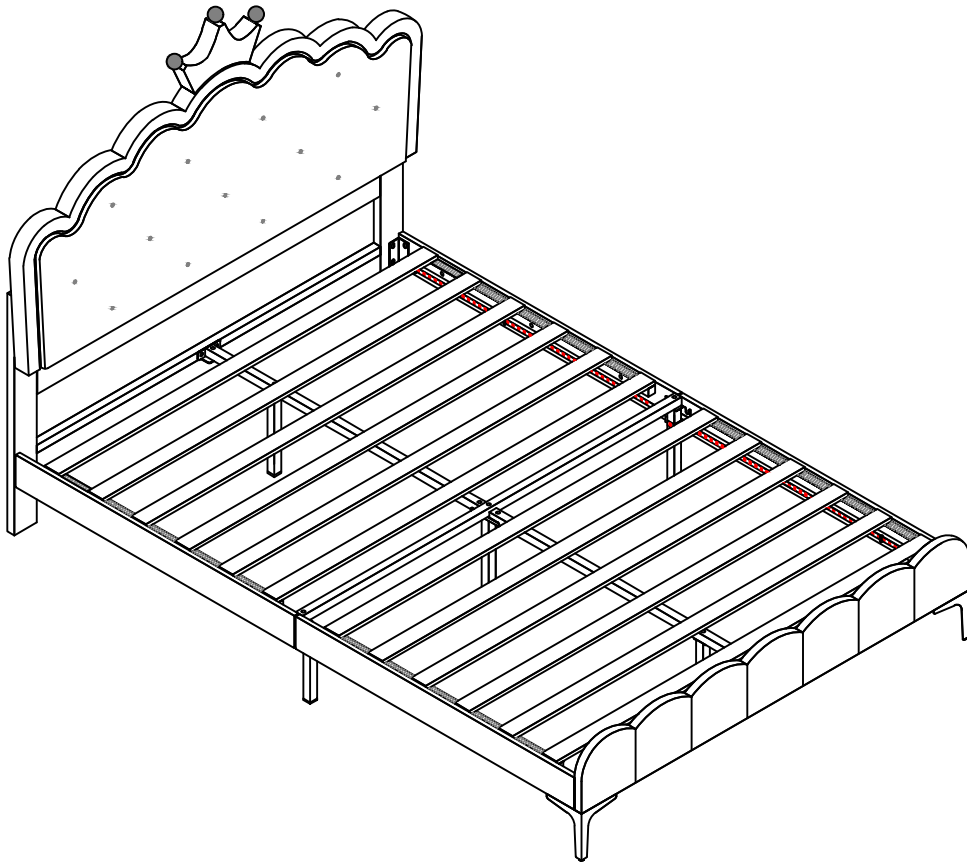

DE:Unser Produkt wird Ihnen in 2 Paketen geliefert. Die Lieferzeiten dieser 2 Pakete können abweichen, bitte haben Sie etwas Geduld und vielen Dank für Ihr Verständnis.

UK:Our product will be delivered to you in 2 packages. The delivery times of these 2 packages may differ, please be patient and thank you for your understanding.

FR:Notre produit vous sera livré en 2 colis. Les délais de livraison de ces 2 colis peuvent différer, soyez patient et merci pour votre compréhension.



English

IMPORTANT ! KEEP FOR FUTURE REFERENCE : READ CAREFULLY

- To be assembled by an adult. Assembly must be checked by an adult before use
- WARNING ! Keep all screws, small parts and plastic bags out of the reach of children
- Properly identify all parts before assembling
- Never use your item if any of its parts are broken or missing
- Should any problems arise, please contact our After Sales Service
- Manufacturer's instructions shall be followed at all times
- Care: Clean with a soft, dry cloth. In case of larger stains, carefully rub with a slightly damp, non-abrasive sponge
- Avoid the risk of fire by not placing furniture near sources of ignition or hot items
- Do not jump on the bed

Deutsch

WICHTIG ! ZUM SPÄTEREN NACHSCHLAGEN AUFBEWAHREN: SORGFÄLTIG LESEN

- Muss von einem Erwachsenen zusammengebaut werden. Der Zusammenbau muss vor dem Gebrauch von einem Erwachsenen überprüft werden
- WARNUNG! Bewahren Sie alle Schrauben, Kleinteile und Plastikbeutel außerhalb der Reichweite von Kindern auf
- Kennzeichnen Sie vor dem Zusammenbau alle Teile richtig
- Benutzen Sie Ihren Artikel niemals, wenn Teile gebrochen sind oder fehlen
- Sollten Probleme auftreten, wenden Sie sich bitte an unseren Kundendienst
- Die Anweisungen des Herstellers sind stets zu befolgen
- Pflege: Mit einem weichen, trockenen Tuch reinigen. Bei größeren Flecken vorsichtig mit einem leicht feuchten, nicht scheuernden Schwamm abreiben. nicht scheuernden Schwamm
- Vermeiden Sie die Gefahr eines Brandes, indem Sie die Möbel nicht in der Nähe von Zündquellen oder heißen Gegenständen aufstellen
- Nicht auf das Bett springen

Français

IMPORTANT ! CONSERVER POUR RÉFÉRENCE ULTÉRIEURE : LIRE ATTENTIVEMENT

- Le montage doit être effectué par un adulte. Le montage doit être vérifié par un adulte avant Utilisation
- ATTENTION ! Tenir les vis, les petites pièces et les sachets en plastique hors de portée des enfants
- Identifiez correctement toutes les pièces avant de les assembler
- N'utilisez jamais votre article si l'une de ses pièces est cassée ou manquante
- En cas de problème, veuillez contacter notre service après-vente
- Les instructions du fabricant doivent être respectées à tout moment
- Entretien : nettoyer avec un chiffon doux et sec. En cas de taches plus importantes, frotter soigneusement avec une éponge non abrasive légèrement humide. légèrement humide et non Abrasive
- Évitez les risques d'incendie en ne plaçant pas les meubles à proximité de sources d'inflammation ou d'objets chauds
- Ne pas sauter sur le lit

Italiano

IMPORTANTE! CONSERVARE PER RIFERIMENTO FUTURO: LEGGERE ATTENTAMENTE

- Deve essere assemblato da un adulto. L'assemblaggio deve essere controllato da un adulto prima dell'uso
- **ATTENZIONE!** Tenere tutte le viti, le piccole parti e i sacchetti di plastica fuori dalla portata dei bambini
- Identificare correttamente tutte le parti prima dell'assemblaggio
- Non utilizzare mai l'articolo se alcune parti sono rotte o mancanti
- In caso di problemi, si prega di contattare il nostro Servizio Post Vendita
- Le istruzioni del produttore devono essere sempre seguite
- Cura: Pulire con un panno morbido e asciutto. In caso di macchie più estese, strofinare accuratamente con una spugna leggermente umida e nonspugna leggermente umida e non abrasiva
- Evitare il rischio di incendio, non collocando i mobili vicino a fonti di accensione o a oggetti caldi
- Non saltare sul letto

Español

¡ IMPORTANTE ! CONSERVELO PARA FUTURAS CONSULTAS: LEA ATENTAMENTE

- Debe ser montado por un adulto. El montaje debe ser comprobado por un adulto antes del uso
- ADVERTENCIA Mantenga todos los tornillos, piezas pequeñas y bolsas de plástico fuera del alcance de los niños.
- Identifique correctamente todas las piezas antes de montarlas
 - Nunca utilice su artículo si alguna de sus piezas está rota o falta
 - Si surge algún problema, póngase en contacto con nuestro Servicio Postventa
 - Las instrucciones del fabricante deben seguirse en todo momento
 - Cuidado: Limpiar con un paño suave y seco. En caso de manchas más grandes, frote cuidadosamente con una esponja no abrasiva ligeramente humedecida.
 - Evite el riesgo de incendio no colocando los muebles cerca de fuentes de ignición u objetos calientes.
 - No saltar sobre la cama.



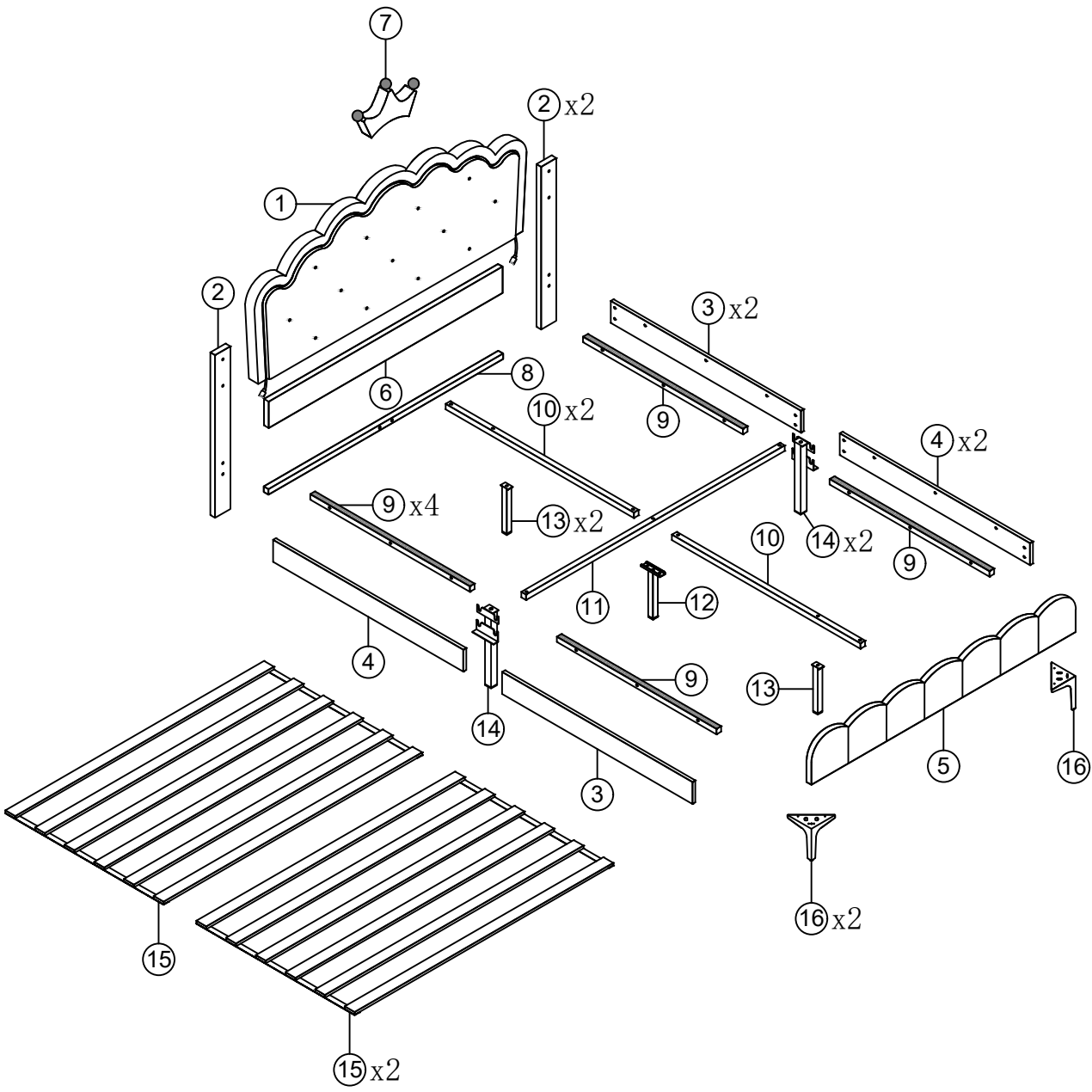

Detailansicht





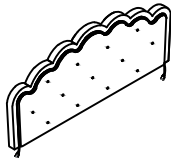

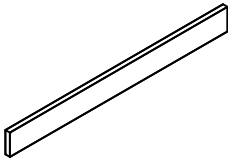
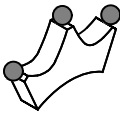
Liste der Einzelteile

N636P223264

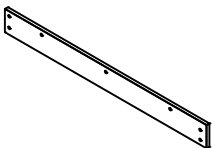
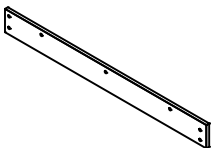
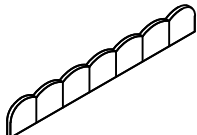
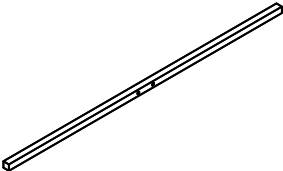
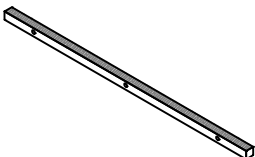
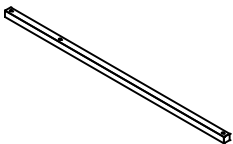
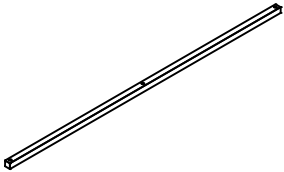



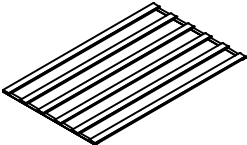
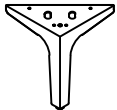





<p>1</p> 	<p>2</p> 	<p>6</p> 
<p>Oberes Kopfteil-1Stück</p>	<p>Beine des Kopfteils-2Stück</p>	<p>Basis-Kopfteil-1Stück</p>
<p>7</p> 		
<p>Krone-1Stück</p>		

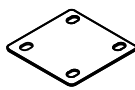
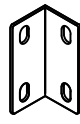
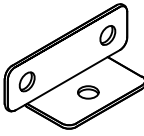
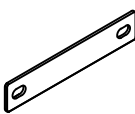

N636P223265

<p>3</p> 	<p>4</p> 	<p>5</p> 
<p>Seitengitte-2Stück</p>	<p>Seitengitte-2Stück</p>	<p>Fußbrett-1Stück</p>
<p>8</p> 	<p>9</p> 	<p>10</p> 
<p>Kopfteil Querstange-1Stück</p>	<p>Seitengitter Stützstange-4Stück</p>	<p>Stützstange in der Mitte-2Stück</p>
<p>11</p> 	<p>12</p> 	<p>13</p> 
<p>Querstrebe-1Stück</p>	<p>Mittelbein verbinden-1Stück</p>	<p>Mittleres Stützbein-2Stück</p>
<p>14</p> 	<p>15</p> 	<p>16</p> 
<p>Seitenschienen Stützbeine-2Stück</p>	<p>Lamelle-2Stück</p>	<p>Bettfüße-2Stück</p>

Hardwareliste

N636P223265

<p>A</p> 	<p>B</p>  <p>M8x16mm</p>	<p>C</p>  <p>M8x40mm</p>
<p>Inbusschlüssel(1Stück)</p>	<p>Bolzen(44Stück)</p>	<p>Bolzen(21Stück)</p>
<p>D</p>  <p>M8x45mm</p>	<p>E</p>  <p>M4x25mm</p>	<p>F</p>  <p>M3x16mm</p>
<p>Bolzen(4Stück)</p>	<p>Nägel(8Stück)</p>	<p>Nägel(28Stück)</p>
<p>G</p> 	<p>H</p> 	<p>I</p> 
<p>Schnalle(14Stück)</p>	<p>Vierloch-Eisenverbinde(3Stück)</p>	<p>"7"-Anschluss(4Stück)</p>
<p>J</p> 	<p>K</p> 	<p>L</p> 
<p>Beschlage fur mittlere Stutzstange(2 Stuck)</p>	<p>Zweiloch-Eisenverbinde(2 Stuck)</p>	<p>LED(1 Stuck)</p>
<p>M</p> 	<p>N</p> 	<p>O</p> 
<p>Farbregler(1 Stuck)</p>	<p>LED-Adapte(1 Stuck)</p>	<p>Fernbedienung(1 Stuck)</p>



<div style="border: 1px solid black; width: 20px; height: 20px; display: flex; align-items: center; justify-content: center; margin-bottom: 5px;">B</div> <div style="text-align: center;">  M8x16mm </div>	<div style="border: 1px solid black; width: 20px; height: 20px; display: flex; align-items: center; justify-content: center; margin-bottom: 5px;">C</div> <div style="text-align: center;">  M8x40mm </div>	<div style="border: 1px solid black; width: 20px; height: 20px; display: flex; align-items: center; justify-content: center; margin-bottom: 5px;">D</div> <div style="text-align: center;">  M8x45mm </div>
Bolzen(44Stück)	Bolzen(21Stück)	Bolzen(4Stück)

DE:Bitte beachten Sie, dass die Formen der Schrauben B und C und D ähnlich sind.

Bitte installieren Sie entsprechend der Anleitung und unterscheiden Sie sie!

UK>Please note that the shapes of screws B and C and D are similar. Please install according to the instructions and distinguish them!

FR:Notez que les vis B et C et D ont des formes similaires. Veuillez les installer en suivant les instructions pour les séparer!

<div style="border: 1px solid black; width: 20px; height: 20px; display: flex; align-items: center; justify-content: center; margin-bottom: 5px;">E</div> <div style="text-align: center;">  M4x25mm </div>	<div style="border: 1px solid black; width: 20px; height: 20px; display: flex; align-items: center; justify-content: center; margin-bottom: 5px;">F</div> <div style="text-align: center;">  M3x16mm </div>
Nägel(8Stück)	Nägel(28Stück)

DE:Bitte beachten Sie, dass die Formen der Schrauben E und F ähnlich sind. Bitte installieren Sie entsprechend der Anleitung und unterscheiden Sie sie!

UK>Please note that the shapes of screws E and F are similar. Please install according to the instructions and distinguish them!

FR:Notez que les vis E et F ont des formes similaires. Veuillez les installer en suivant les instructions pour les séparer!

DE: Vor dem Einbau die Schrauben in die Löcher stecken und festziehen, aber nicht bis 100%, 70% bis 80% anziehen reicht aus. Schließlich, nachdem alle Schrauben installiert sind, ziehen Sie alle Schrauben auf 100%.

Wenn Sie auf diese Probleme stoßen, wie z. B. Fehlausrichtung der Löcher oder Unfähigkeit, bestimmte Teile zu installieren, überprüfen Sie bitte, ob die Schrauben korrekt verwendet werden und passen Sie die Dichtigkeit der Schrauben an.

UK: Before installation, insert the screws into the holes and tighten them, but do not tighten them to 100%, 70% to 80% is sufficient. Finally, after all screws are installed, tighten all screws to 100%.

If you encounter these issues, such as if the holes cannot be aligned or some parts cannot be installed, please check if the screws are used correctly and adjust the tightness of the screws.





FR: Insérer la vis dans le trou avant la fin de l'assemblage, serrer la vis, mais ne pas serrer à 100%, 70% ~ 80% est correct. Enfin, une fois que toutes les vis sont bien serrées, toutes les vis sont serrées à 100%.

Si vous rencontrez ces problèmes, par exemple si les trous ne sont pas alignés ou si certaines pièces ne peuvent pas être montées, vérifiez que les vis sont utilisées correctement et Ajustez leur serrage.

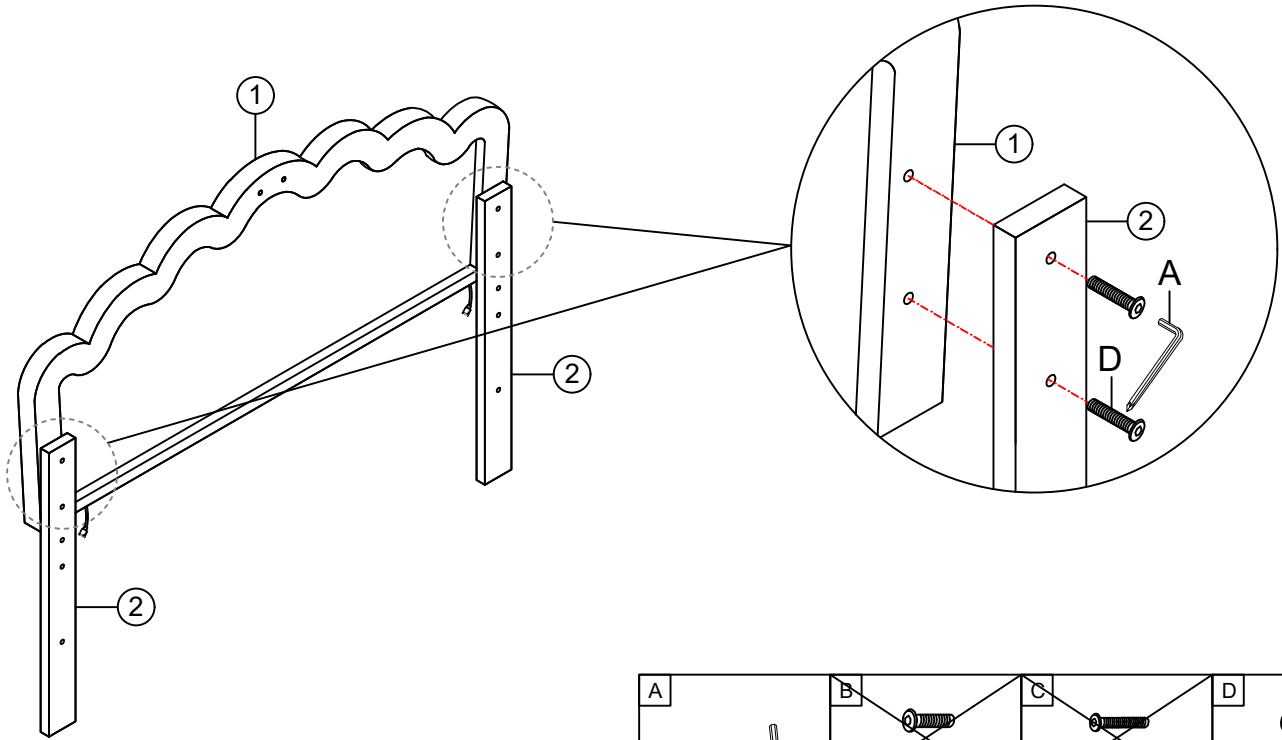
Hinweis: Wir empfehlen Ihnen, Ihr Bett im ebenen Boden aufzubauen.





Schritt 1:

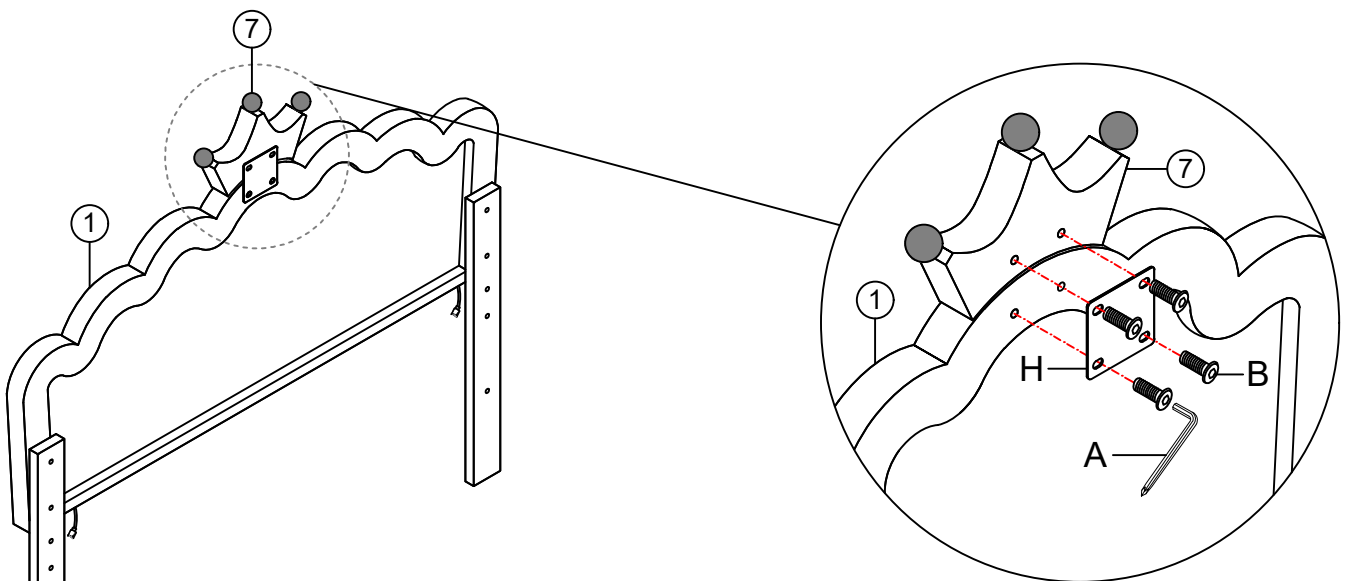

A	B	C	D
	 M8x16mm	 M8x40mm	 M8x45mm 4Stück





Schritt 2:

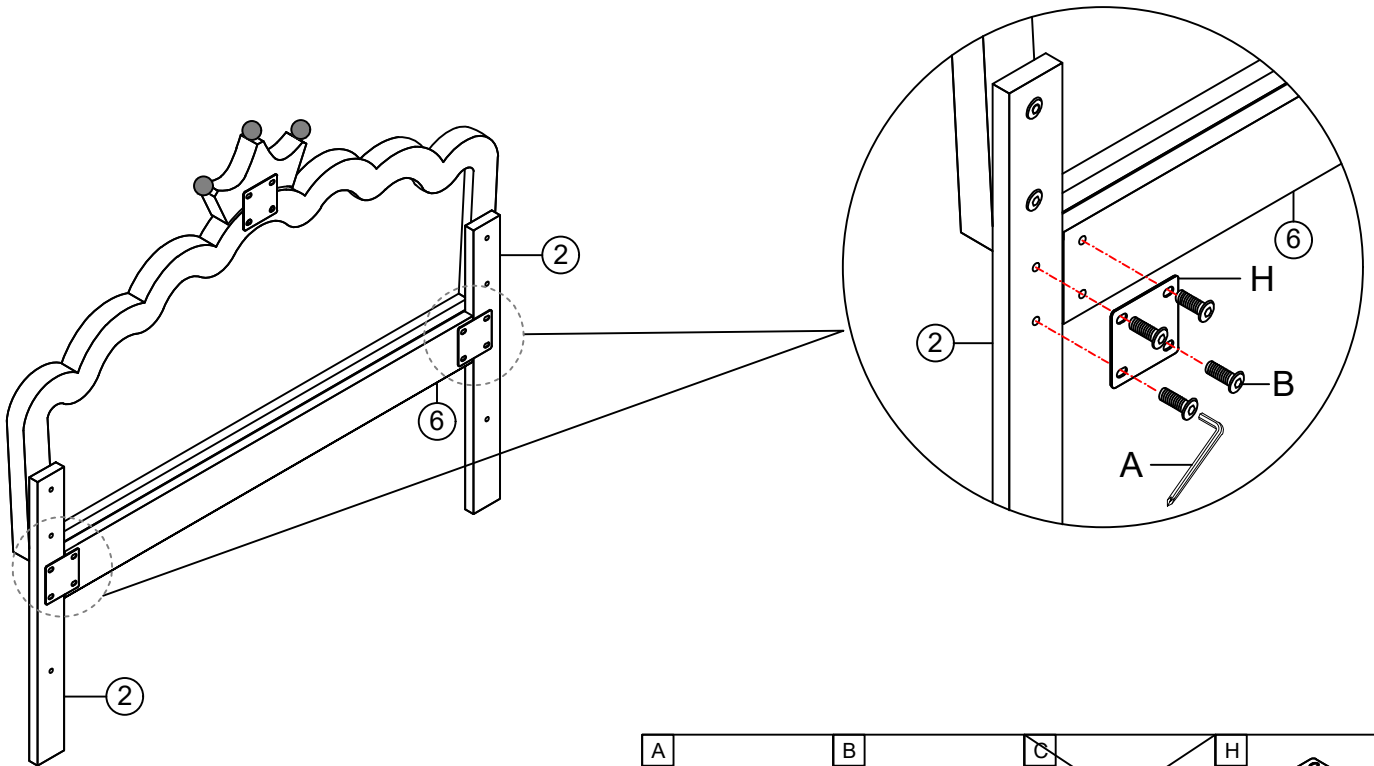

A	B	C	H
	 M8x16mm 4Stück	 M8x40mm	 1Stück





Schritt 3:

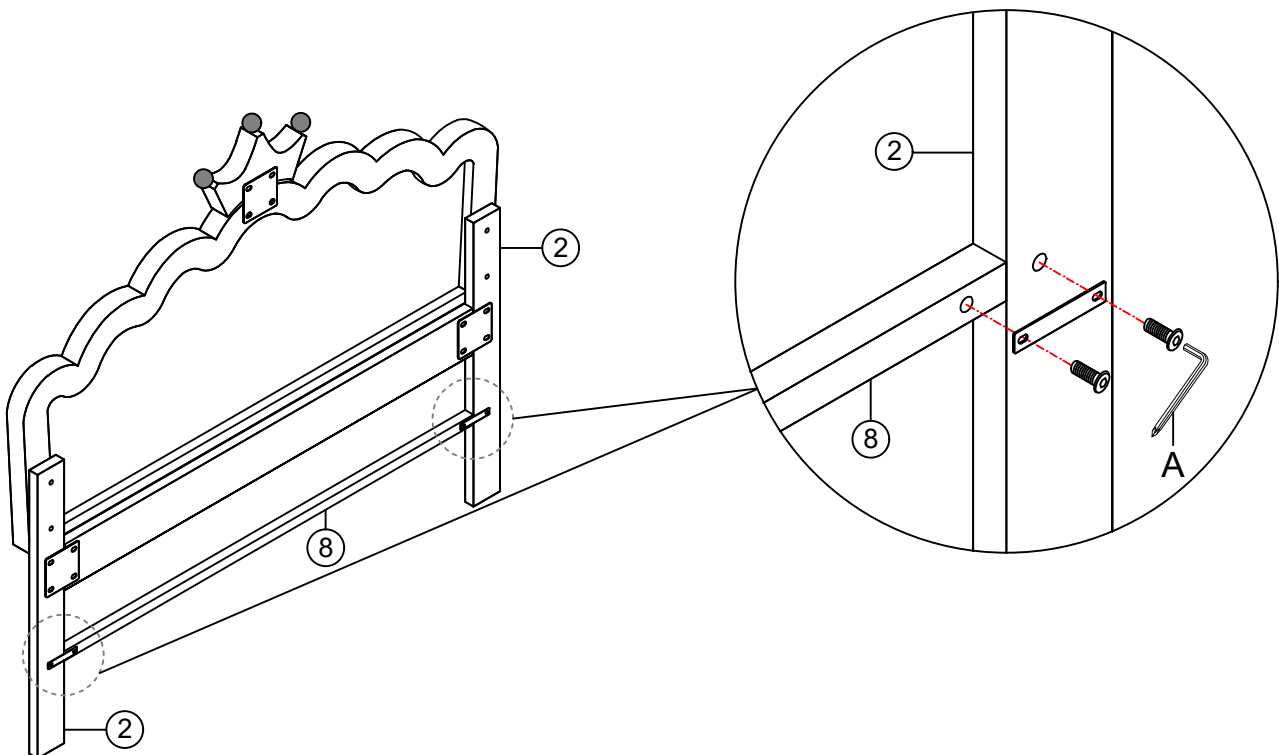

<p>A</p> 	<p>B</p>  <p>M8x16mm</p> <p>8Stück</p>	<p>C</p>  <p>M8x40mm</p>	<p>H</p>  <p>2Stück</p>
--	---	---	--

Schritt 4:



<p>A</p> 	<p>B</p>  <p>M8x16mm</p> <p>4Stück</p>	<p>C</p>  <p>M8x40mm</p>	<p>K</p>  <p>2Stück</p>
--	---	---	--

Schritt 5:

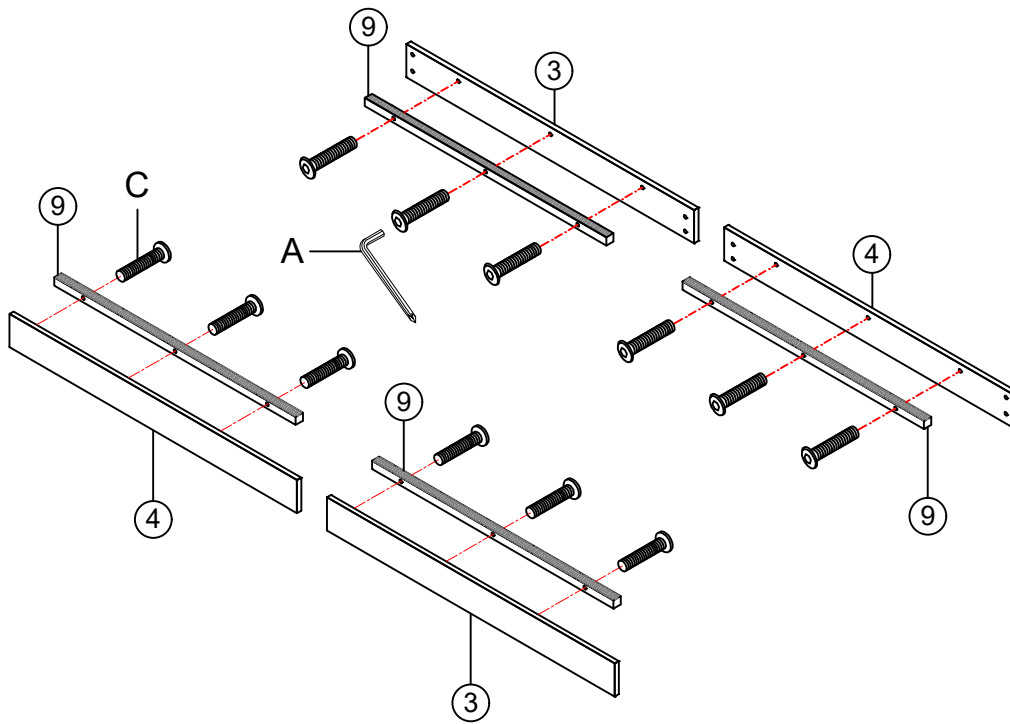

<p>A</p>	<p>B</p> <p>M8x16mm</p>	<p>C</p> <p>M8x40mm</p> <p>12Stück</p>
----------	-------------------------	--



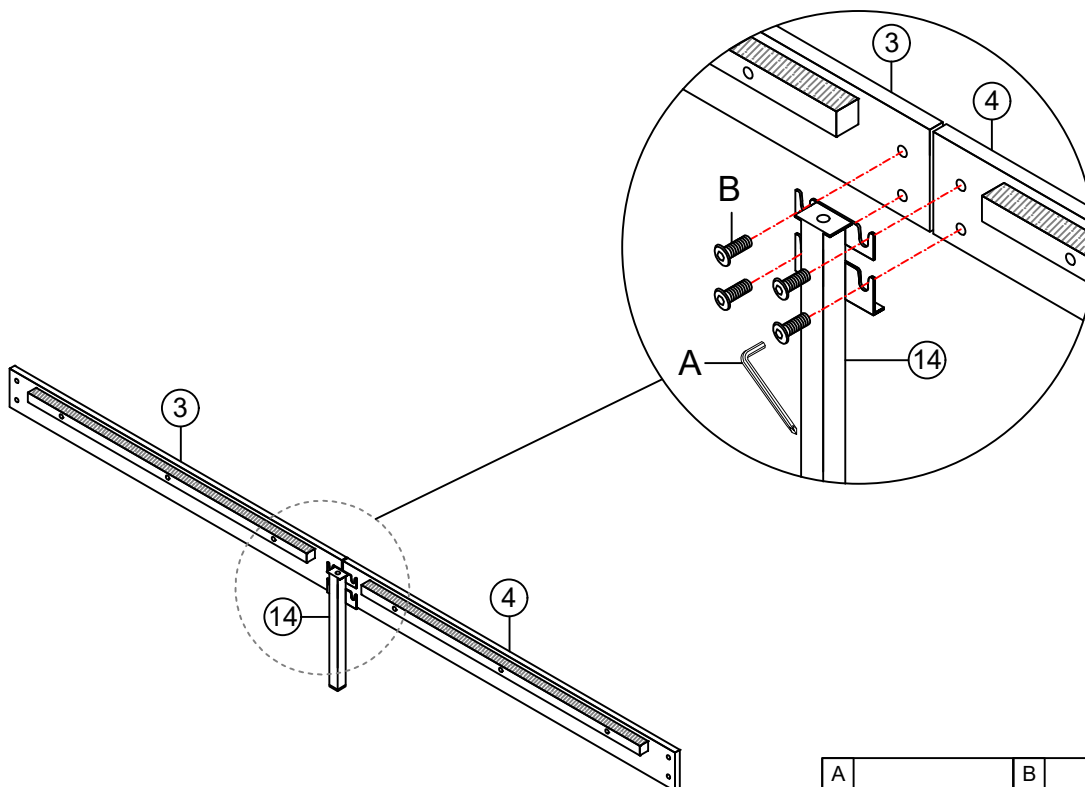

Schritt 6x2:

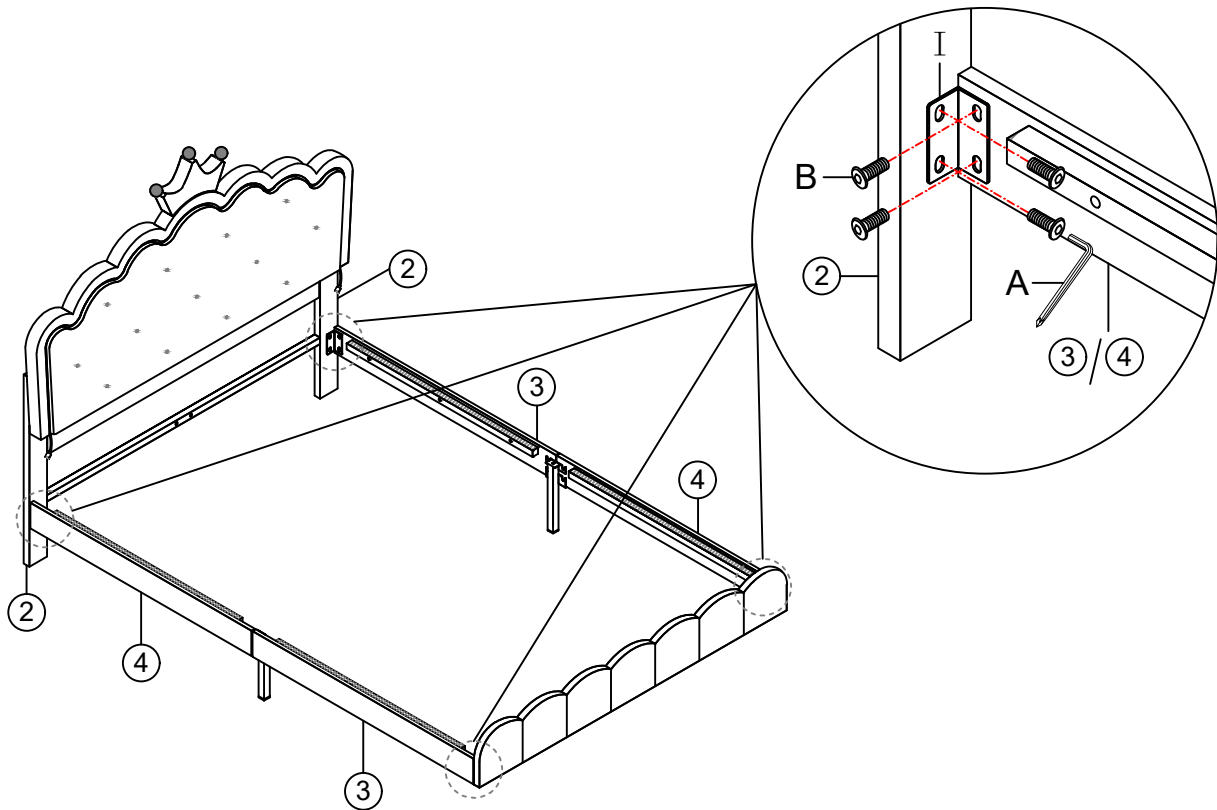

<p>A</p>	<p>B</p> <p>M8x16mm</p> <p>8Stück</p>	<p>C</p> <p>M8x40mm</p>
----------	---------------------------------------	-------------------------



Schritt 7:



<p>A</p> 	<p>B</p>  <p>M8x16mm</p> <p>16Stück</p>	<p>C</p>  <p>M8x40mm</p>	<p>I</p>  <p>4Stück</p>
--	--	---	--

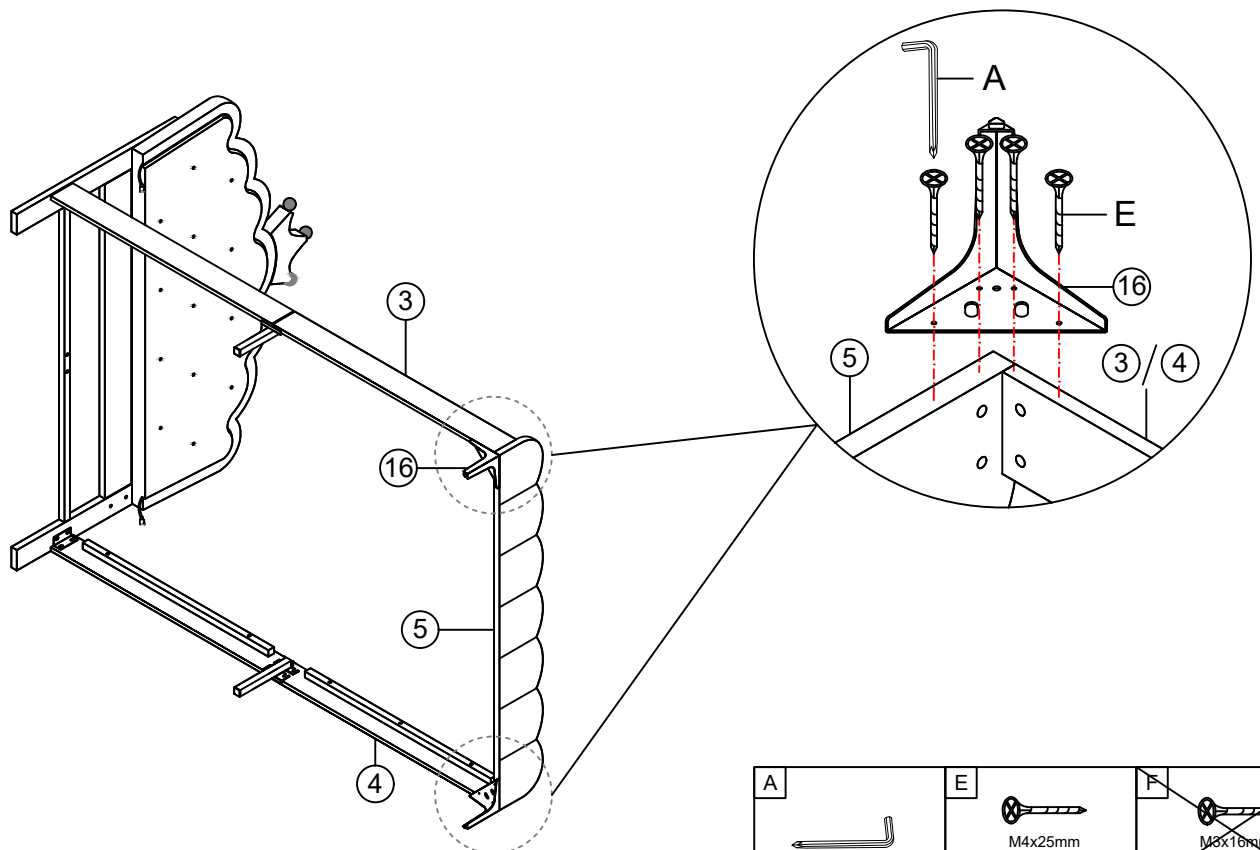



Schritt 8:

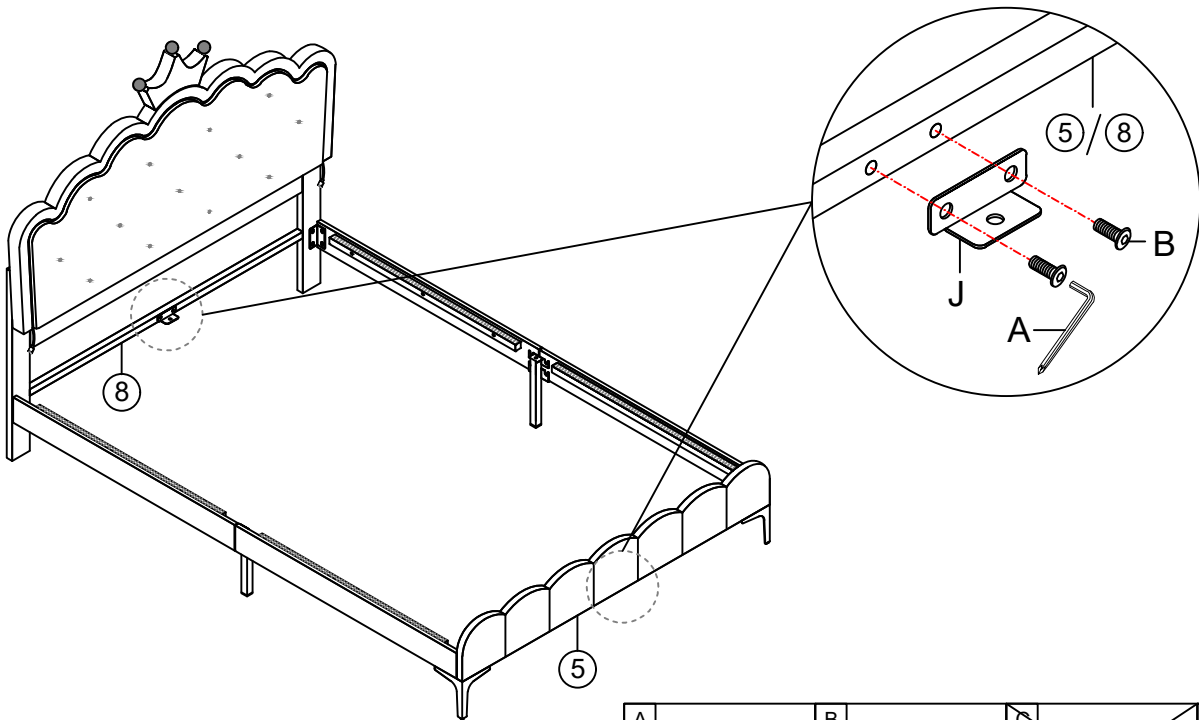

<p>A</p> 	<p>E</p>  <p>M4x25mm</p> <p>8Stück</p>	<p>F</p>  <p>M8x16mm</p>
---	---	---



Schritt 9:



<p>A</p> 	<p>B</p>  <p>M8x16mm</p> <p>4Stück</p>	<p>C</p>  <p>M8x40mm</p>	<p>J</p>  <p>2Stück</p>
---	--	--	---

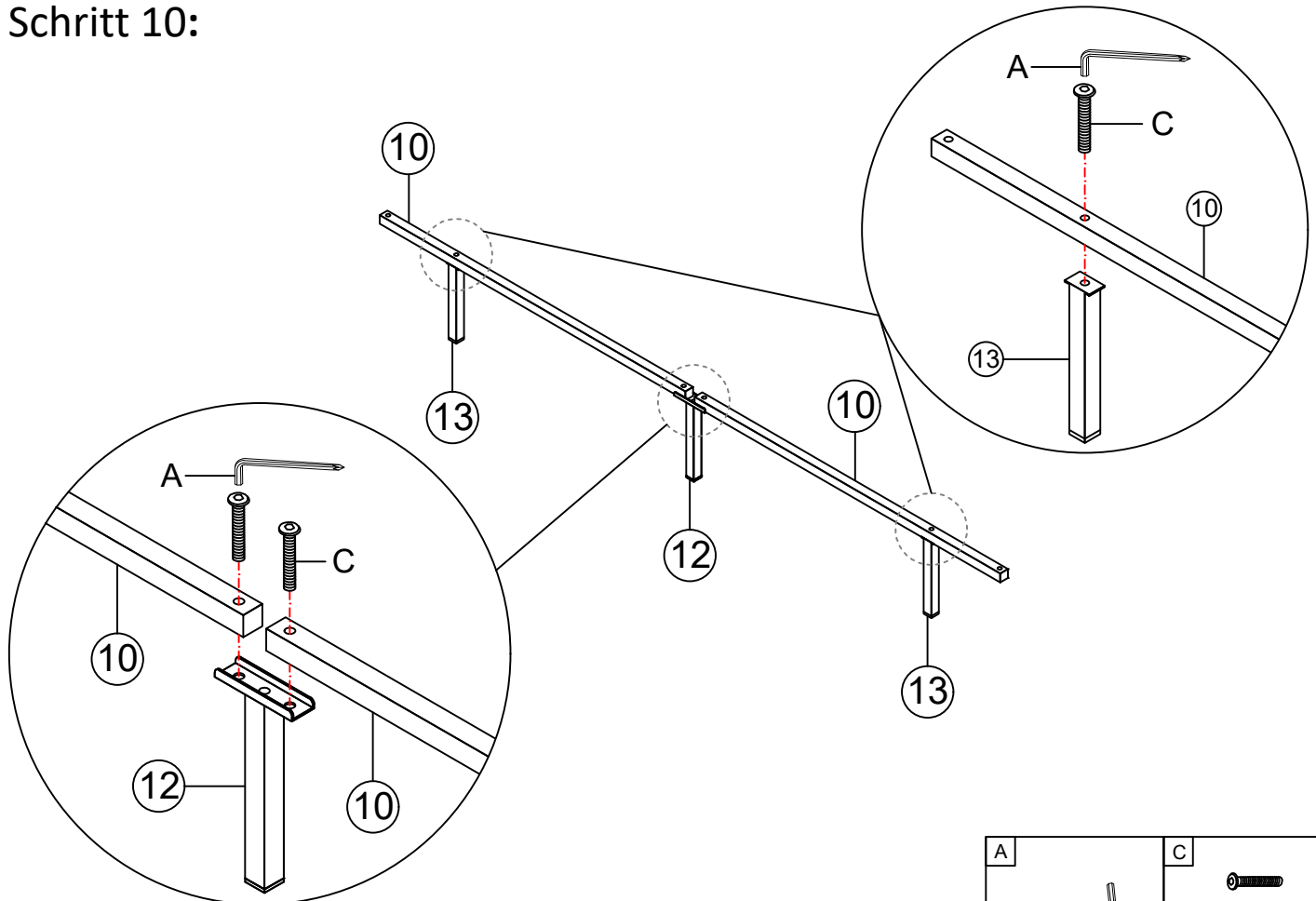

Schritt 10:



<p>A</p> 	<p>C</p>  <p>M8x40mm</p> <p>4Stück</p>
---	--

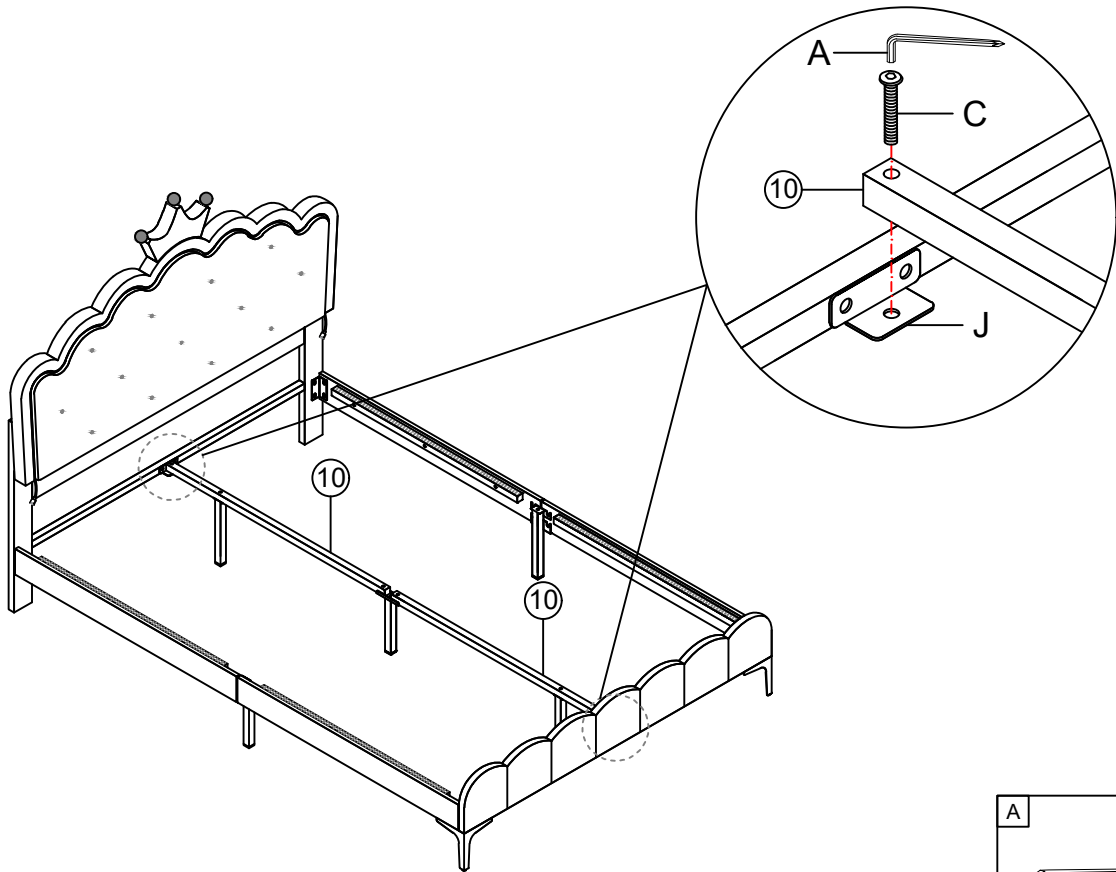

Schritt 11:



A	C
	 M8x40mm
2Stück	

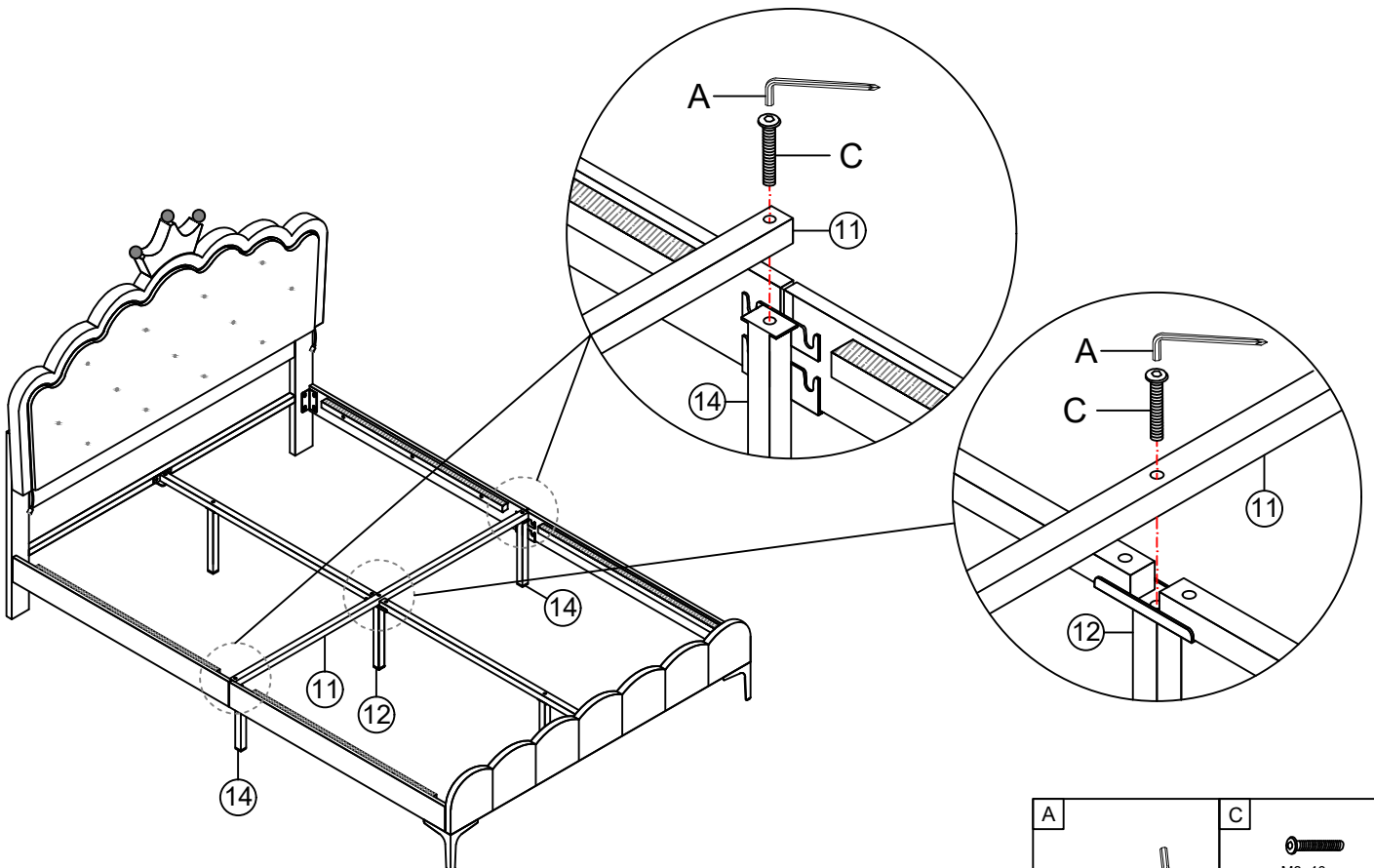



Schritt 12:

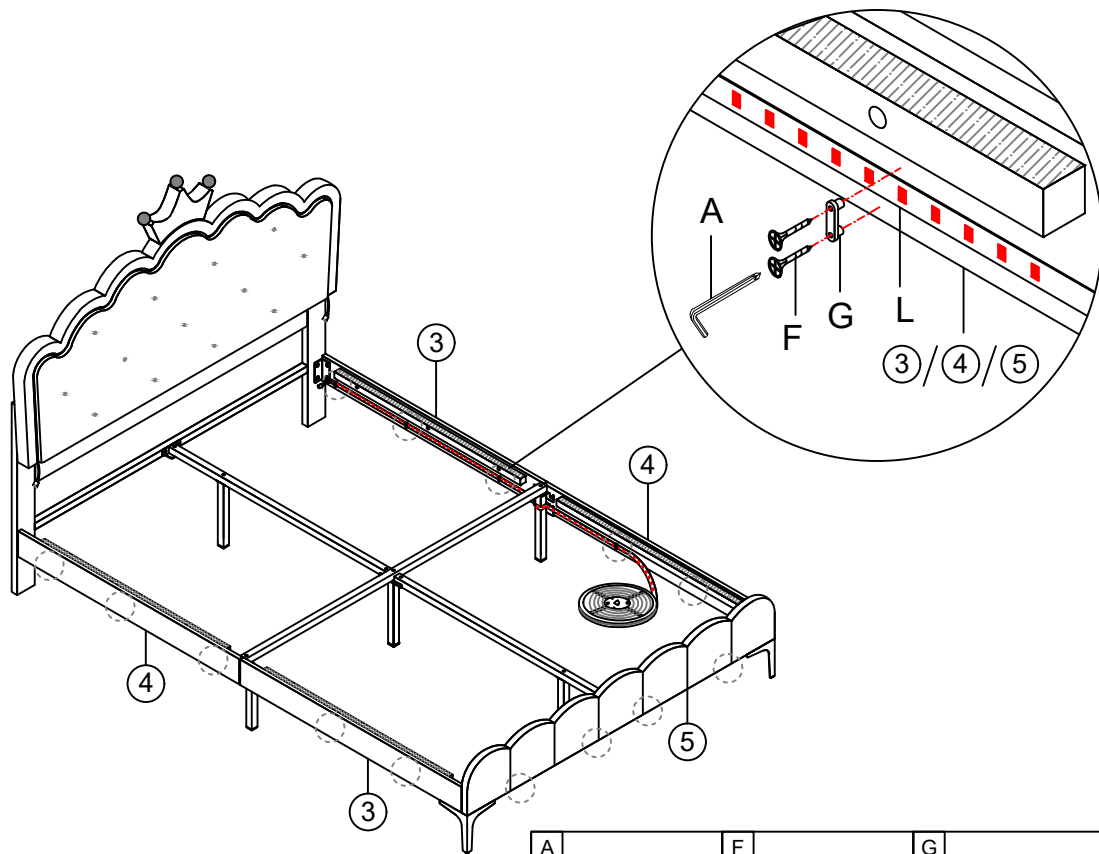

A	C
	 M8x40mm
3Stück	

Schritt 13:



<p>A</p> 	<p>F</p>  <p>M3x16mm</p> <p>28Stück</p>	<p>G</p>  <p>14Stück</p>	<p>L</p>  <p>1Stück</p>
--	--	---	--

Schritt 14:

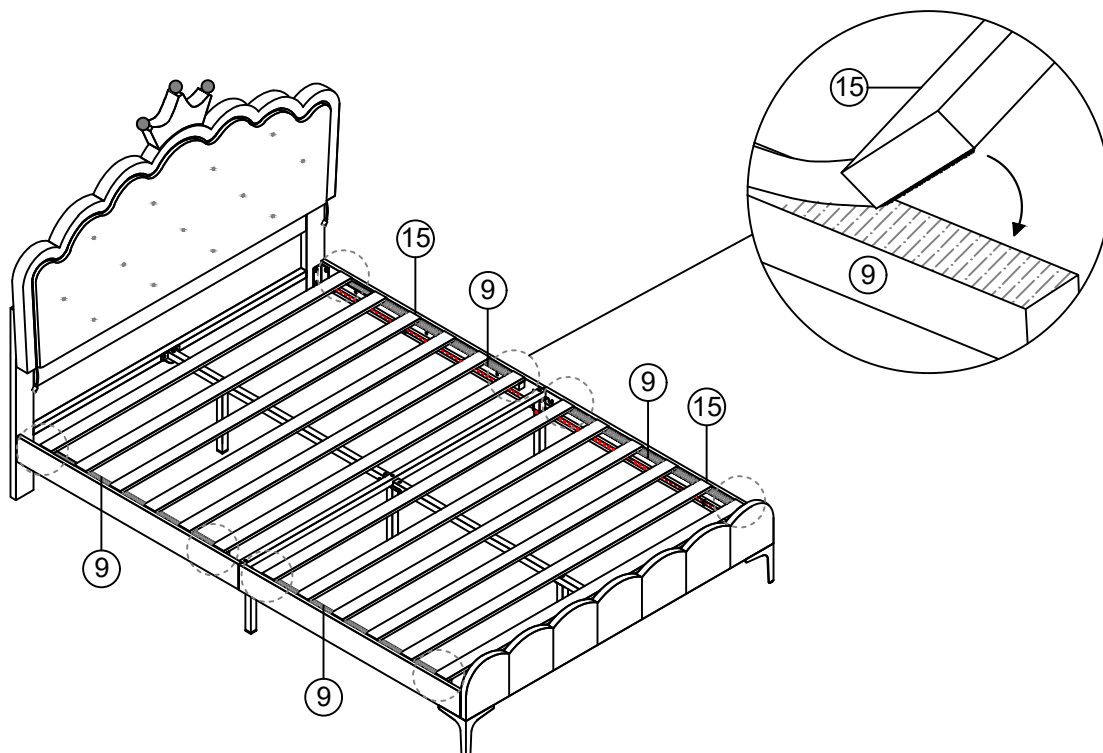

Schritt 15:

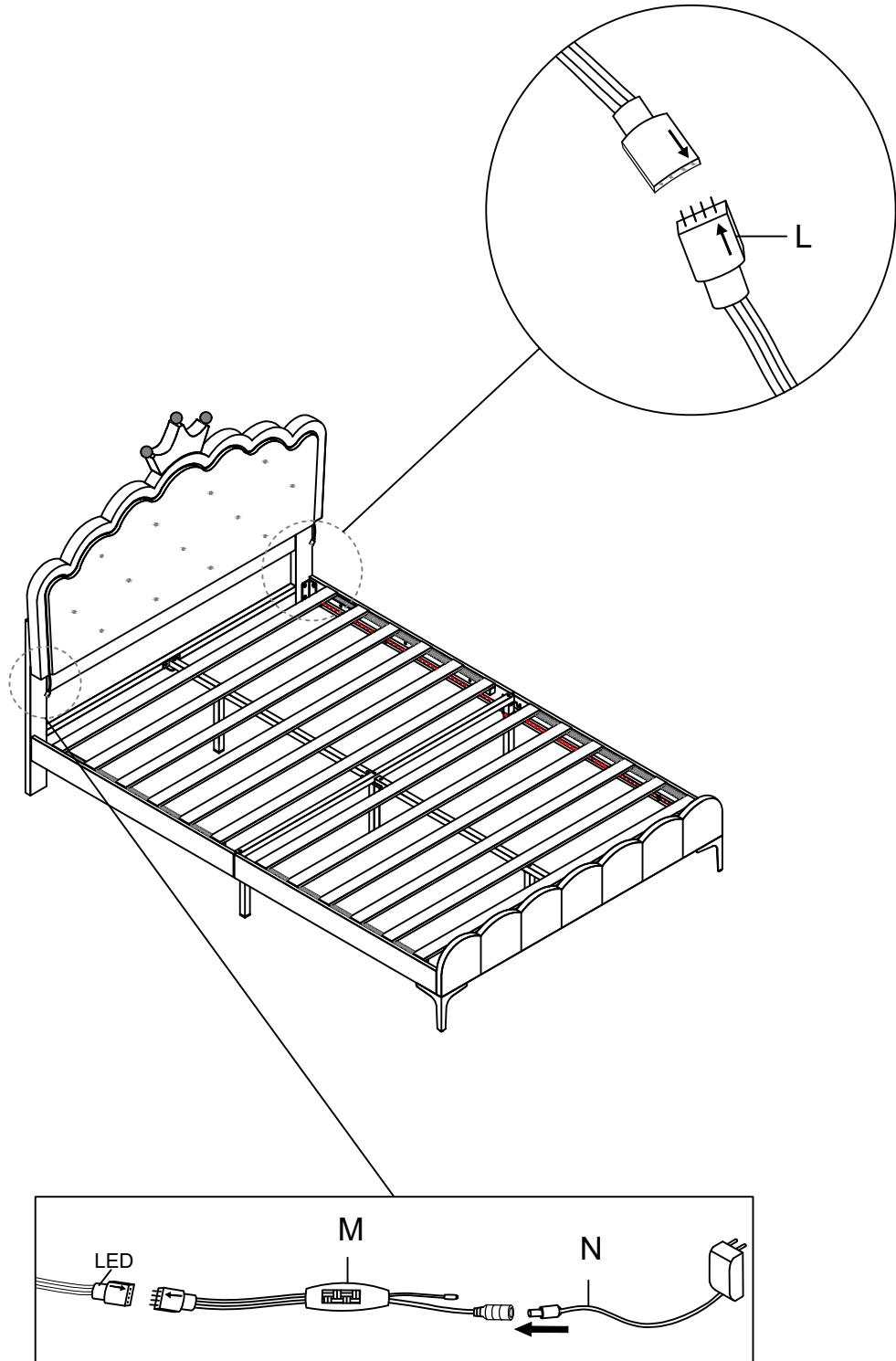

M	N
1Stück	1Stück

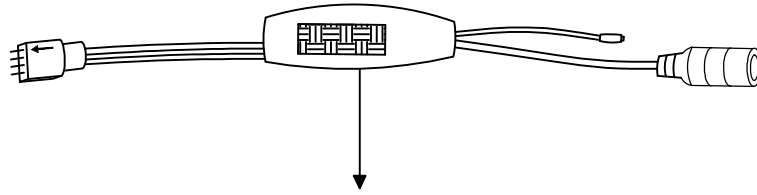

HINWEIS:

Hier können Sie den QR-Code scannen und eine App herunterladen, mit der Sie die Farbe des Lichtstreifens wie mit einer Fernbedienung steuern können. Wenn Ihr Telefon über die App Musik abspielt, ändert sich auch die Farbe des Lichtstreifens entsprechend der Stärke der Musik.

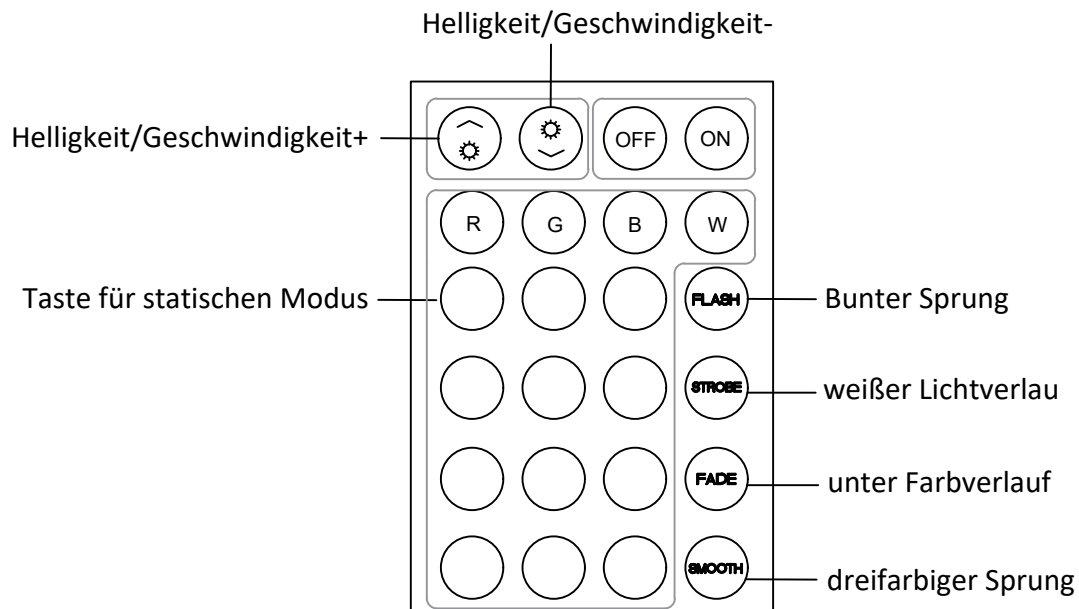

NOTICE:

Wenn Sie die Fernbedienungsplatine verwenden, um die Farbe des Lichts zu steuern, entfernen Sie bitte zuerst die durchsichtige Plastikkarte und achten Sie dann darauf, die Fernbedienung auf den Farbreger s zu richten.

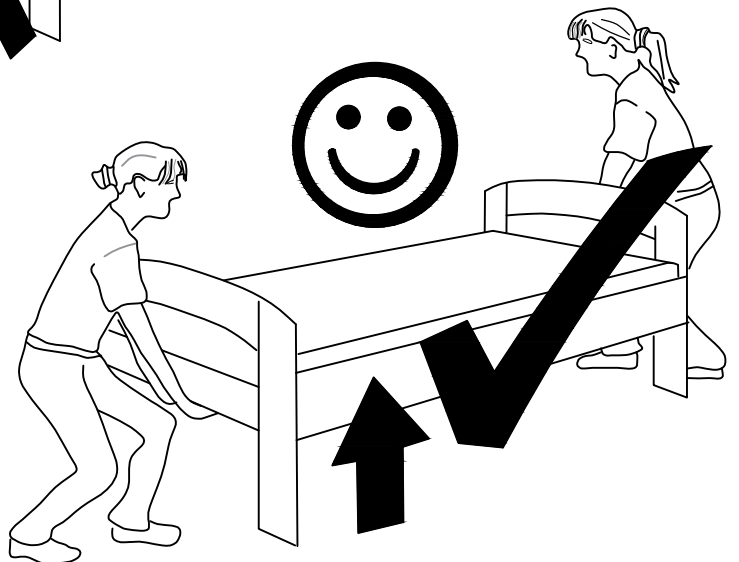
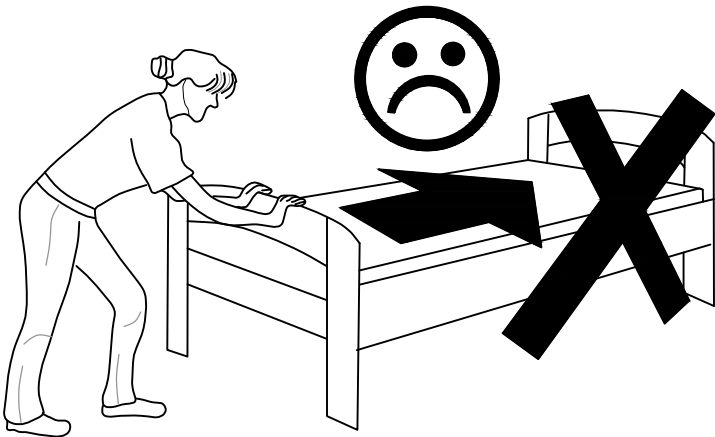
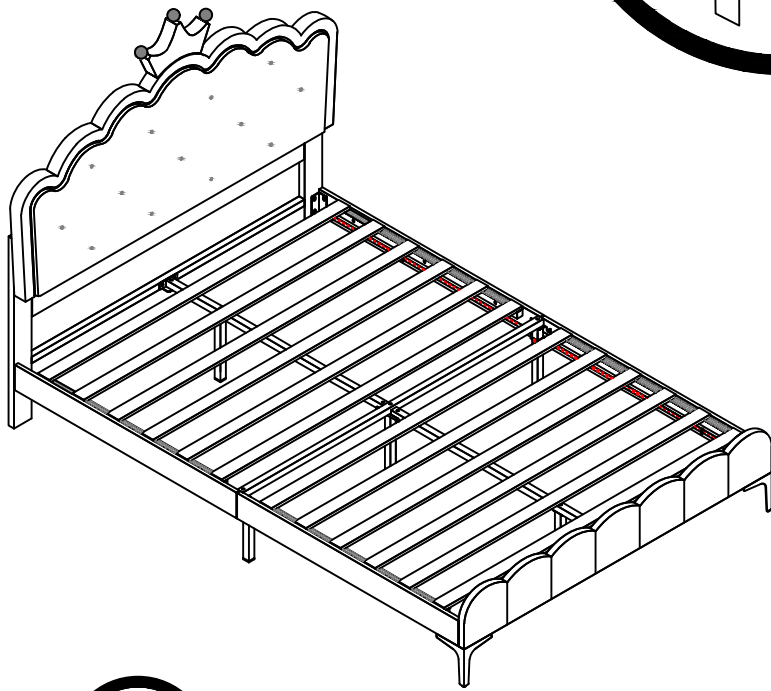

GB – NOTE: The battery in the remote control requires you to purchase and install it yourself.
Model: CR2025 3.V

DE – HINWEIS: Die Batterie in der Fernbedienung müssen Sie selbst kaufen und installieren
Modell: CR2025 3.V

FR – REMARQUE : la pile de la télécommande doit être achetée et installée par vos soins.
Modèle : CR2025 3.V

IT – NOTA: la batteria del telecomando deve essere acquistata e installata autonomamente.
Modello: CR2025 3.V

ES – NOTA: La pila del mando a distancia debe comprarla e instalarla usted mismo
Modelo CR2025 3.V



Modell : CR2025 3.V



Verification of Compliance

Verification No.:	MK23020083-P01C01
Name and address of Applicant:	Shenzhen Hongzhengyu Technology Co., LTD Shenzhen baoan district rock street industrial science and technology industrial park of 2 Haitian lanyu 3 5 floor of A
Name and address of Manufacturer:	Shenzhen Hongzhengyu Technology Co., LTD Shenzhen baoan district rock street industrial science and technology industrial park of 2 Haitian lanyu 3 5 floor of A
Product name:	Lamp strip HZY-2835-120D-12V, HZY-2835-30D-5V, HZY-2835-60D-5V, HZY-2835-120D-5V, HZY-2835-60D-12V, HZY-2835-60D-24V, HZY-2835-120D-24V, HZY-2835RGB-60D-5V, HZY-2835RGB-60D-12V, HZY-5050-30D-5V, HZY-5050-60D-5V, HZY-5050-30D-12V, HZY-5050-60D-12V, HZY-5050-60D-24V, HZY-5050RGB-30D-5V, HZY-5050RGB-60D-5V, HZY-5050RGB-30D-12V, HZY-5050RGB-60D-12V, HZY-5050RGB-60D-24V
Product model(s):	
Product trademark:	N/A

This verification confirms that the product meets the requirements of the following standard.

The conformity was demonstrated based on following standard(s) listed by European Commission as harmonized with Directive RoHS 2.0 Directive (EU) 2015/863 and (EU)2017/2102 amending Annex II to Directive 2011/65/EU

IEC 62321-1:2013	IEC 62321-3-1:2013
IEC 62321-4:2013/AMD1:2017	IEC 62321-5:2013
IEC 62321-6:2015	IEC 62321-7-1:2015
IEC 62321-7-2:2017	IEC 62321-8:2017

The verification has been carried out in accordance with individual rules and conditions agreed with the applicant. Evaluation has been carried out in accordance with:

Test report(s) No.:	MK23020083-P01C01
Test conducted by:	TMC Testing Services (Shenzhen) Co., Ltd.
Verification issue date:	February 25, 2023

Notes:

This verification refers to the above mentioned product and its conformity in regards of above mentioned standard(s) was proven on test sample.

This verification does not imply meeting all essential requirements, assessment of the series-production or any other restricted Notified Bodies conformity assessment procedure appropriate for the product.

This verification holder shall use this verification in connection to verification of conformity and technical data relevant for the product the verification was issued.

TMC Testing Services (Shenzhen) Co., Ltd.

t:86-755-86642861 cert@tmc-lab.com www.tmc-lab.com

1st Floor, Block A1, Zone A, Xinshidai Gongrong Industrial Park, No. 2, Shihuan Road, Shiyuan Street, Baoan District, Shenzhen, China



Lab Director
Vivian Jiang





CERTIFICATE OF CONFORMITY

Electromagnetic Compatibility (EMC) Directive 2014/30/EU

This Certificate of Conformity is hereby issued to the product designated below:

Certificate No. : 24EP01101E01
Report No. : EP2401101E01
Date Issue. : 2024-04-28
Applicant's name : Guangdong Sangu Technology Co., Ltd
Address : 402, Chuangye building, 8-28, Shaqi community Central Road, Xinqiao street, Bao'an District, Shenzhen.
Manufacturer's name : Guangdong Sangu Technology Co., Ltd
Address : 402, Chuangye building, 8-28, Shaqi community Central Road, Xinqiao street, Bao'an District, Shenzhen.
Product Description : POWER ADAPTER
Model(s)/Type References : SG-050yyyyz, GA-050yyyyz, GAT-050yyyyz, HZ-050yyyyz, SG-050yyyyAz, GA-050yyyyAz, GAT-050yyyyAz, HZ-050yyyyAz, SG-050yyyyAzC, GA-050yyyyAzC, GAT-050yyyyAzC, HZ-050yyyyAzC, SG-xxxyyyy12Az (xxx, yyyy, z are variables, appendix for details)
Parameters : See appendix for details
Standard(s) : EN 55032:2015+A11:2020+A1:2020
EN 55035:2017+A11:2020
EN IEC 61000-3-2:2019+A1:2021
EN 61000-3-3:2013+A1:2019+A2:2021

On the basis of the referenced test report(s), sample(s) tested of the above product have been found to comply with the standards harmonized with the directives listed on this verification at the time the tests were carried out. Other standards and Directives may be relevant to the product. This verification is part of the full test report(s) and should be read in conjunction with it(them).

Once compliance with all product relevant CE mark directives are verified, including any relevant e.g. risk assessment and production control, the manufacturer may indicate compliance by signing a Declaration of Conformity themselves and applying the mark to products identical to the tested sample(s).

Approved By

.....
Eric Liu
Director of engineering department



Dongguan Pubiao Testing Technology Co., Ltd

No. 3, 1/F., Building A, No.30, Minghua Road, Juzhou, Shijie, Dongguan, Guangdong, China

Tel: +86 769 81813516 E-mail: service@pubiaotest.com Web: www.pubiaotest.com



CERTIFICATE OF CONFORMITY

Electromagnetic Compatibility (EMC) Directive 2014/30/EU

Appendix of Certificate No.: 24EP01101E01

Table A: Definition of variables

Variable	Range of variable	Content
xxx	050-240	3 digits, indicates 10 times of output voltage in V and in step of 0.1V. eg. 050=5.0V, 240=24.0V.
yyyy	0100-2100	4 digits, indicates 1000 times of output current in A and in step of 0.01A. eg. 0100=0.1A, 2100=2.1A.
z	E, B	One capital letter representing the plug type for different countries. E represents European plug and Russian plug; B represents British plug.

Table B: Model list and input / output ratings

Model	Rated input	Rated output			Transformer
		Voltage range (VDC)	Current range (A)	Max. Power (W)	
SG-050yyyyz, GA-050yyyyz, GAT-050yyyyz, HZ-050yyyyz, SG-050yyyyAz, GA-050yyyyAz, GAT-050yyyyAz, HZ-050yyyyAz, SG-050yyyyAzC, GA-050yyyyAzC, GAT-050yyyyAzC, HZ-050yyyyAzC,	100-240V~, 50/60Hz, 0.3A Max.	5.0	0.1-2.0	10.0	EF1510
SG-xxxxyyy12Az	100-240V~, 50/60Hz, 0.6A Max.	5.0-5.5	0.10-2.1	11.55	EF1510-1
		5.6-12.0	0.10-2.0	12.00	
		12.1-24.0	0.10-1.0	12.00	



Dongguan Pubiao Testing Technology Co., Ltd

No. 3, 1/F., Building A, No.30, Minghua Road, Juzhou, Shijie, Dongguan, Guangdong, China

Tel: +86 769 81813516 E-mail: service@pubiaotest.com Web: www.pubiaotest.com