

Installation sanleitung

Installation Instruction

Instruction d'installation

SKU:N616P248007N/N616P248008N

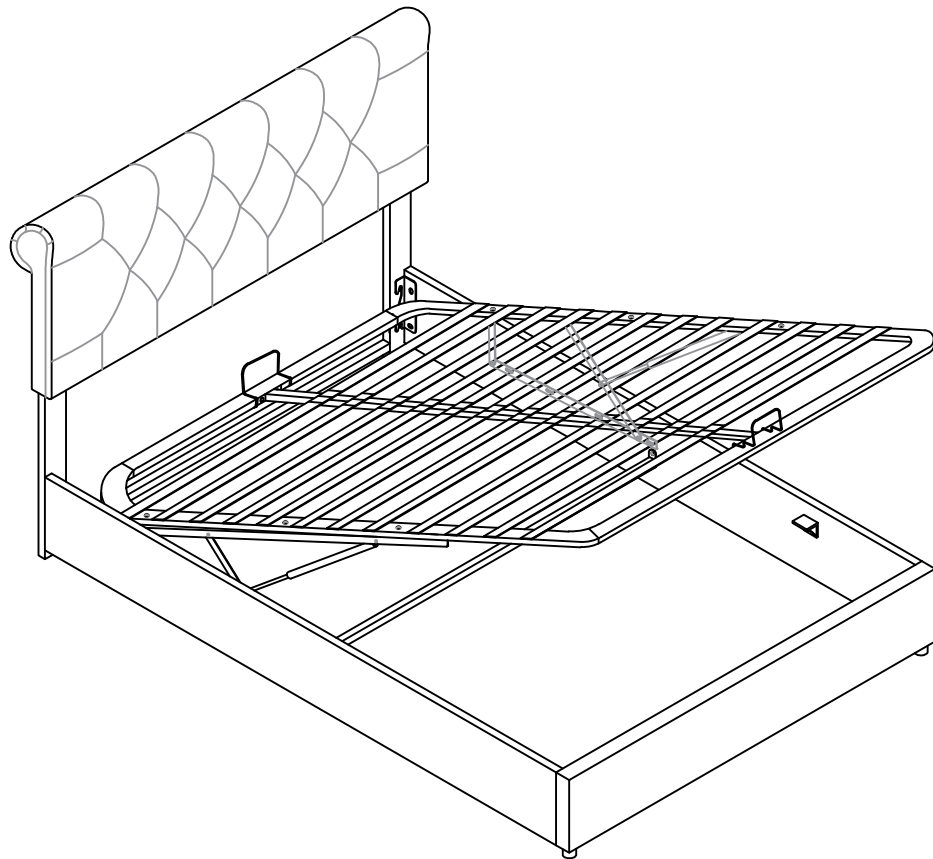

Unser Produkt wird Ihnen in 2 Paketen geliefert. Die Lieferzeiten dieser 2 Pakete können abweichen, bitte haben Sie etwas Geduld und vielen Dank für Ihr Verständnis.

Our product will be delivered to you in 2 packages. The delivery times of these 2 packages may differ, please be patient and thank you for your understanding.

Notre produit vous sera livré en 2 colis. Les délais de livraison de ces 2 colis peuvent différer, soyez patient et merci pour votre compréhension.

English

IMPORTANT FOR GAS LIFT BEDS&MAINTAINCE

- Please place the mattress on top of the bed frame.
- Please do not pull on the strap handles.
- Please press heavily to release the compressed gas.
- Periodically check all screw & fixings to ensure they are secure.
- When moving your product, carefully lift into place.
- Wipe clean with a slightly damp cloth- please do not use abrasive chemicals or bleach.
- Do NOT allow children to operate the lift mechanism.
- Do NOT allow children near the lift base when operating the mechanism.
- Do NOT stand inside the bed or the internal storage base.
- Do NOT overload the internal storage base.
- DO NOT jump on the product or any of its parts.

Deutsch

WICHTIG FÜR GASLIFT-BETTEN&WARTUNG

- Bitte legen Sie die Matratze oben auf den Bettrahmen.
- Bitte ziehen Sie nicht an den Gurtgriffen.
- Bitte drücken Sie kräftig, um das komprimierte Gas freizusetzen.
- Überprüfen Sie regelmäßig alle Schrauben und Befestigungen, um sicherzustellen, dass sie sicher sind.
- Wenn Sie Ihr Produkt bewegen, heben Sie es vorsichtig an seinen Platz.
- Mit einem leicht feuchten Tuch abwischen - bitte keine scheuernden Chemikalien oder Bleichmittel verwenden.
- Erlauben Sie Kindern NICHT, den Hebemechanismus zu bedienen.
- Lassen Sie Kinder NICHT in die Nähe des Liftsockels, wenn Sie den Mechanismus bedienen.
- Stellen Sie sich NICHT in das Bett oder in die Innenablage.
- Überlasten Sie den internen Liftsockel NICHT.
- Springen Sie NICHT auf das Produkt oder eines seiner Teile.

Français

IMPORTANT POUR LES LITS À RELEVAGE DE GAZ&MAINTENANCE

- Veuillez placer le matelas sur le dessus du cadre de lit.
- Ne tirez pas sur les poignées de la sangle.
- Appuyez fortement pour libérer le gaz comprimé.
- Vérifiez régulièrement que toutes les vis et fixations sont bien en place.
- Lorsque vous déplacez votre produit, soulevez-le avec précaution pour le mettre en place.
- Nettoyez avec un chiffon légèrement humide - n'utilisez pas de produits chimiques abrasifs ou d'eau de Javel.
- Ne laissez pas les enfants utiliser le mécanisme de levage.
- Ne laissez pas les enfants s'approcher de la base de levage lorsqu'ils actionnent le mécanisme.
- Ne vous tenez PAS à l'intérieur du lit ou de la base de stockage interne.
- Ne surchargez pas la base de stockage interne.
- Ne pas sauter sur le produit ou l'une de ses parties.

Italiano

IMPORTANTE PER I LETTI CON SOLLEVAMENTO A GAS E LA MANUTENZIONE

- Posizionare il materasso sopra la struttura del letto.
- Non tirare le maniglie della cinghia.
- Premere con forza per rilasciare il gas compresso.
- Controllare periodicamente tutte le viti e i fissaggi per assicurarsi che siano saldi.
- Quando si sposta il prodotto, sollevarlo con cautela.
- Pulire con un panno leggermente umido, senza usare prodotti chimici abrasivi o candeggina.
- NON permettere ai bambini di azionare il meccanismo di sollevamento.
- NON permettere ai bambini di avvicinarsi alla base di sollevamento quando si aziona il meccanismo.
- NON sostare all'interno del letto o della base di contenimento interna.
- NON sovraccaricare la base di contenimento interna.
- NON saltare sul prodotto o sulle sue parti.

Español

IMPORTANTE PARA LAS CAMAS ELEVADORAS DE GAS & MANTENIMIENTO



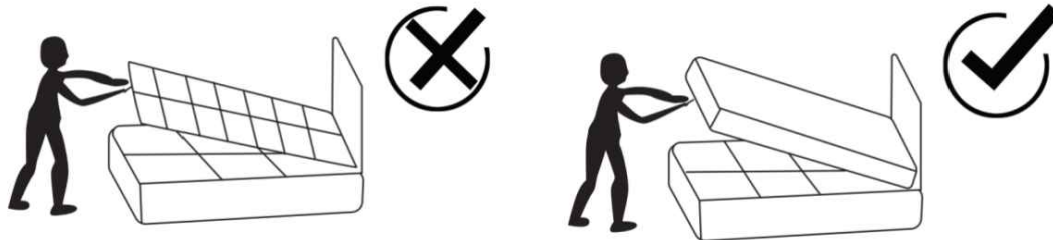

- Coloque el colchón sobre el somier.
- No tire de las asas de la correa.
- Presione con fuerza para liberar el gas comprimido.
- Compruebe periódicamente que todos los tornillos y fijaciones estén bien sujetos.
- Al mover el producto, levántelo con cuidado para colocarlo en su sitio.
- Limpie con un paño ligeramente humedecido; no utilice productos químicos abrasivos ni lejía.
- NO permita que los niños accionen el mecanismo de elevación.
- NO permita que los niños se acerquen a la base elevadora cuando accionen el mecanismo.
- NO se ponga de pie dentro de la cama o de la base de almacenamiento interna.
- NO sobrecargue el somier.
- NO salte sobre el producto ni sobre ninguna de sus piezas.

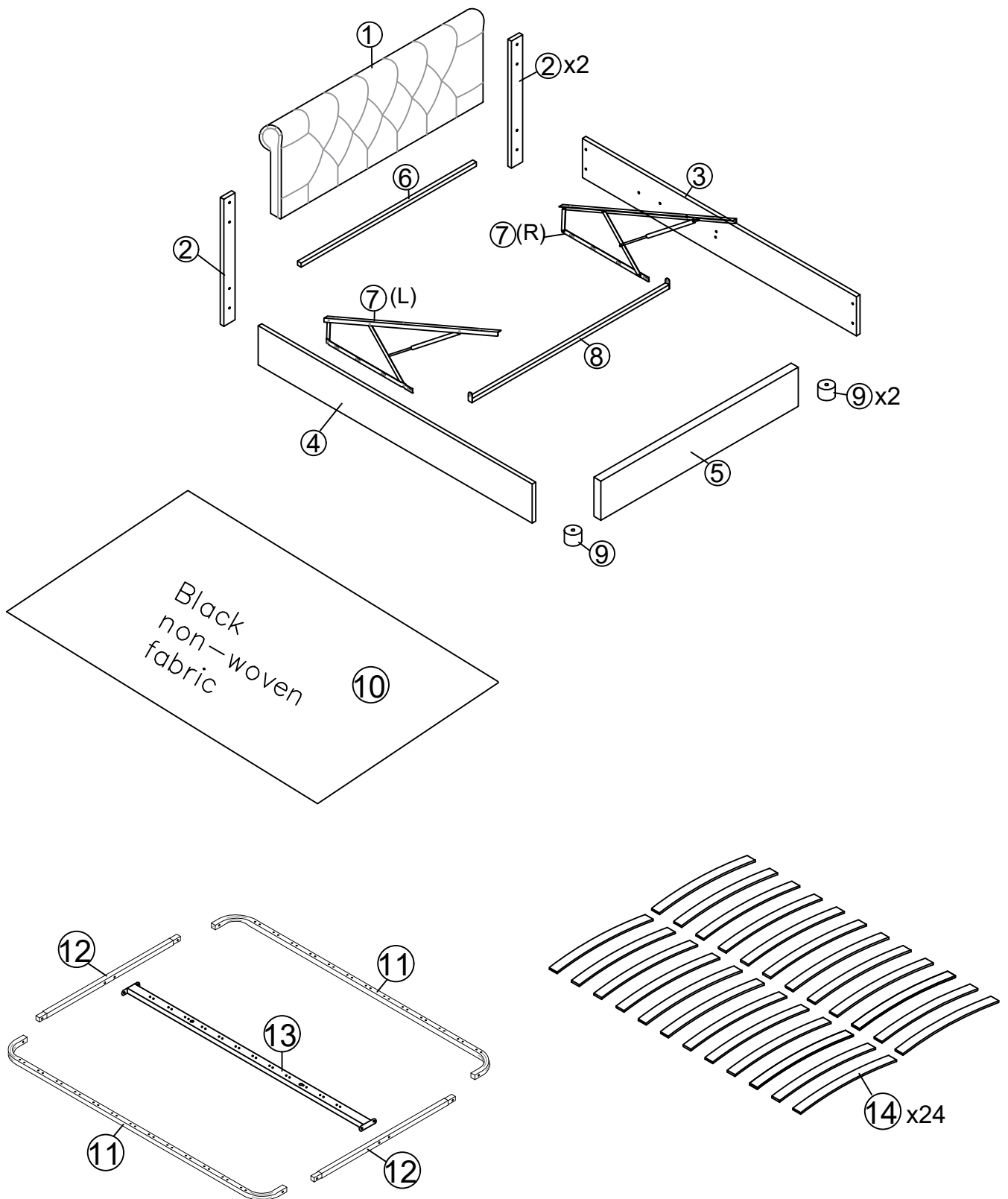

Stückliste

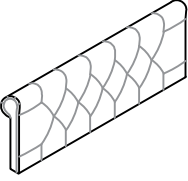

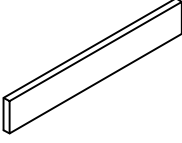
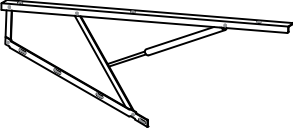
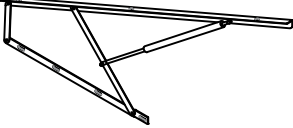
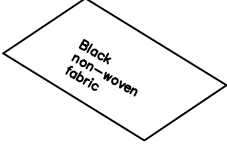
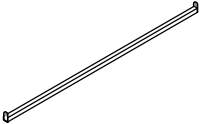





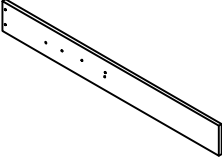
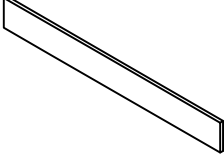
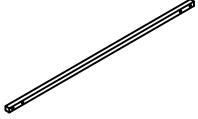
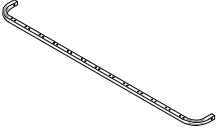
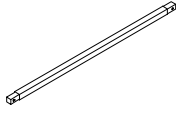
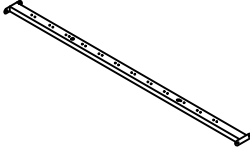
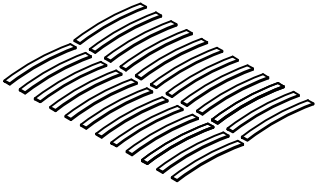





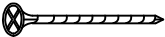

Part List-Stückliste N616P248007N

<p>①x1</p> 	<p>②x2</p> 	<p>⑤x1</p> 
<p>⑦Lx1</p> 	<p>⑦Rx1</p> 	<p>⑩x1</p> 
<p>⑧x1</p> 	<p>⑨x2</p> 	

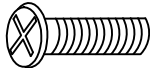
Part List-Stückliste N616P248008N

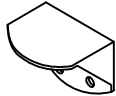
<p>③x1</p> 	<p>④x1</p> 	<p>⑥x1</p> 
<p>⑪x2</p> 	<p>⑫x2</p> 	<p>⑬x1</p> 
<p>⑭x24</p> 		

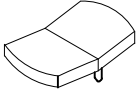
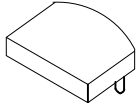
Hardware List- Hardware-Liste N616P248007N

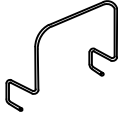
<p>A x1</p> 	<p>B x20</p>  <p>M8x45mm</p>	<p>C x4</p> 
<p>D x22</p>  <p>M8x18mm</p>	<p>E x14</p> 	<p>F x12</p>  <p>M4x25mm</p>
<p>G x2</p>  <p>M4x50mm</p>	<p>H x2</p> 	<p>I x10</p>  <p>M6x25mm</p>
<p>J x1</p> 	<p>K x4</p> 	<p>L x4</p> 
<p>M x2</p> 	<p>N x12</p> 	<p>O x24</p> 
<p>P x1</p> 	<p>Q x2</p> 	<p>R x1</p> 

Step 1

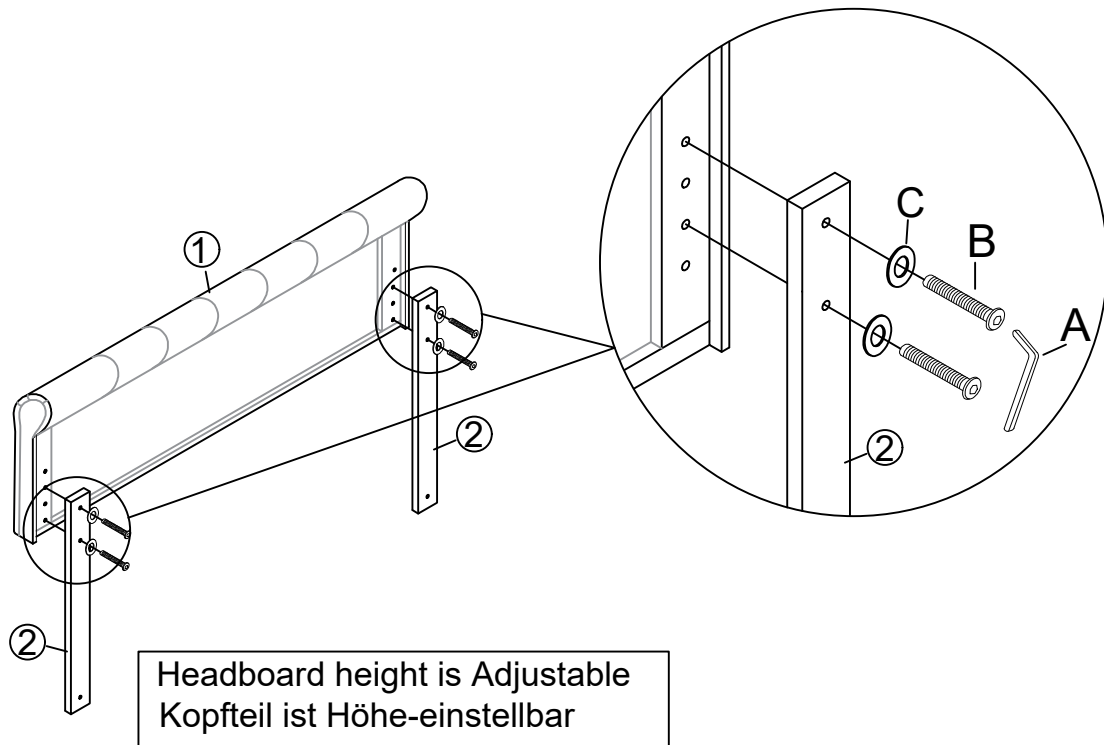

A x1	C x4	B x4
		M8X45mm

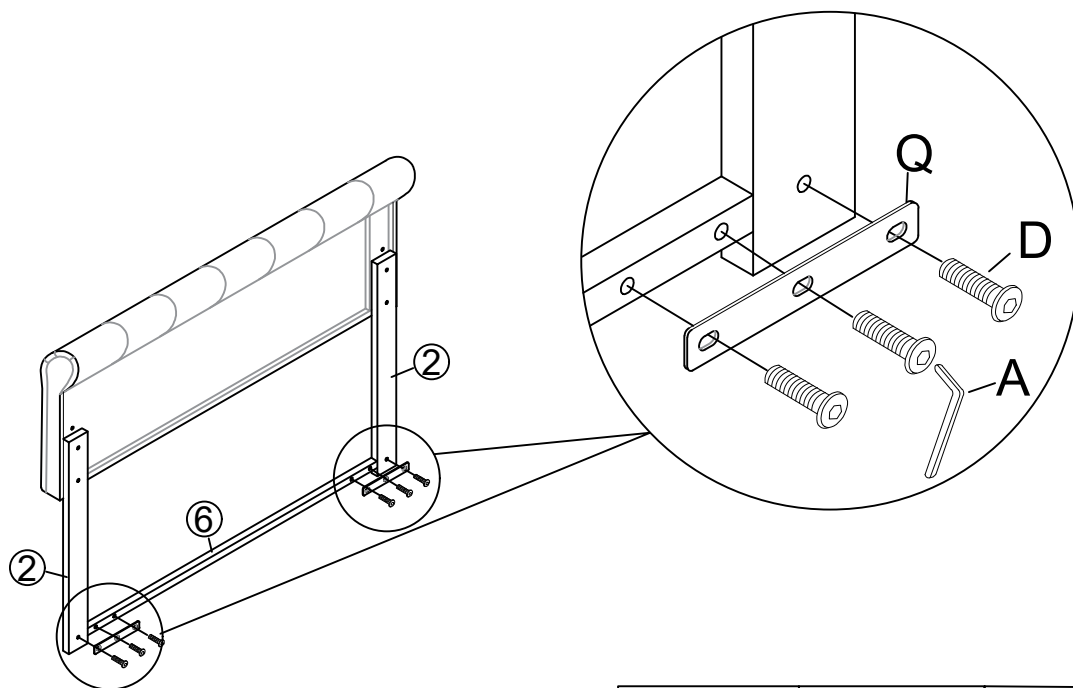

Step 2



A x1	D x6	Q x2
	M8X18mm	

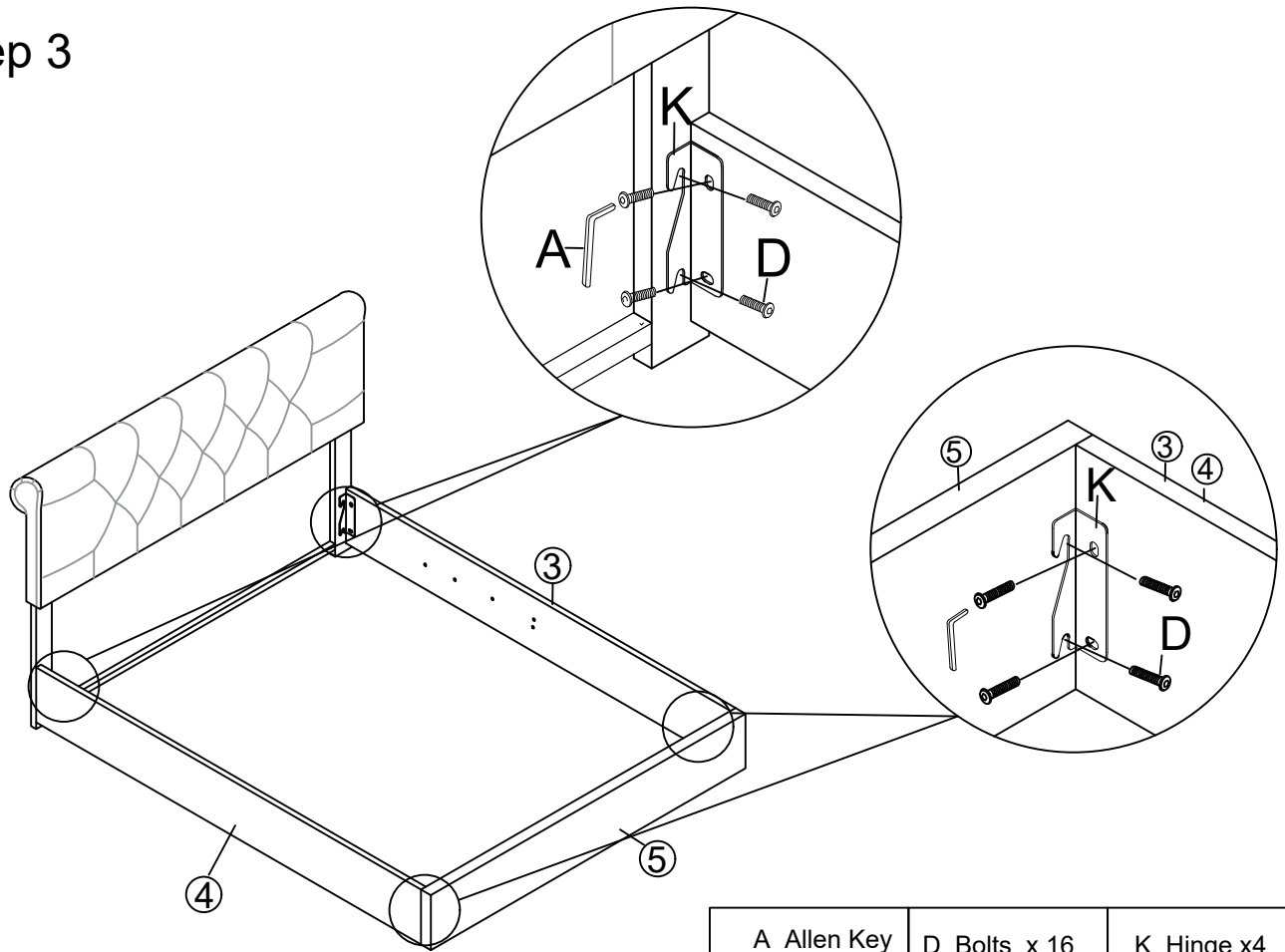

Step 3



A Allen Key	D Bolts x 16 M8X18mm	K Hinge x4
		

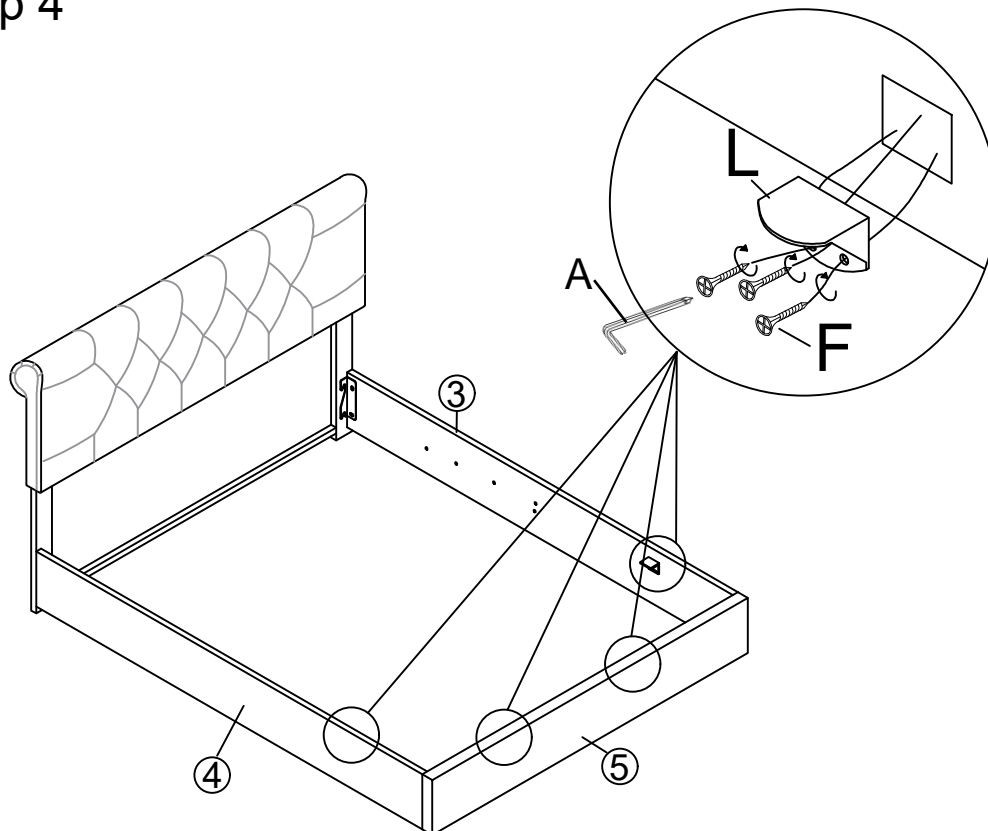

Step 4



A Allen Key	F Nails x12 M4X25mm	L Plastic support x4
		

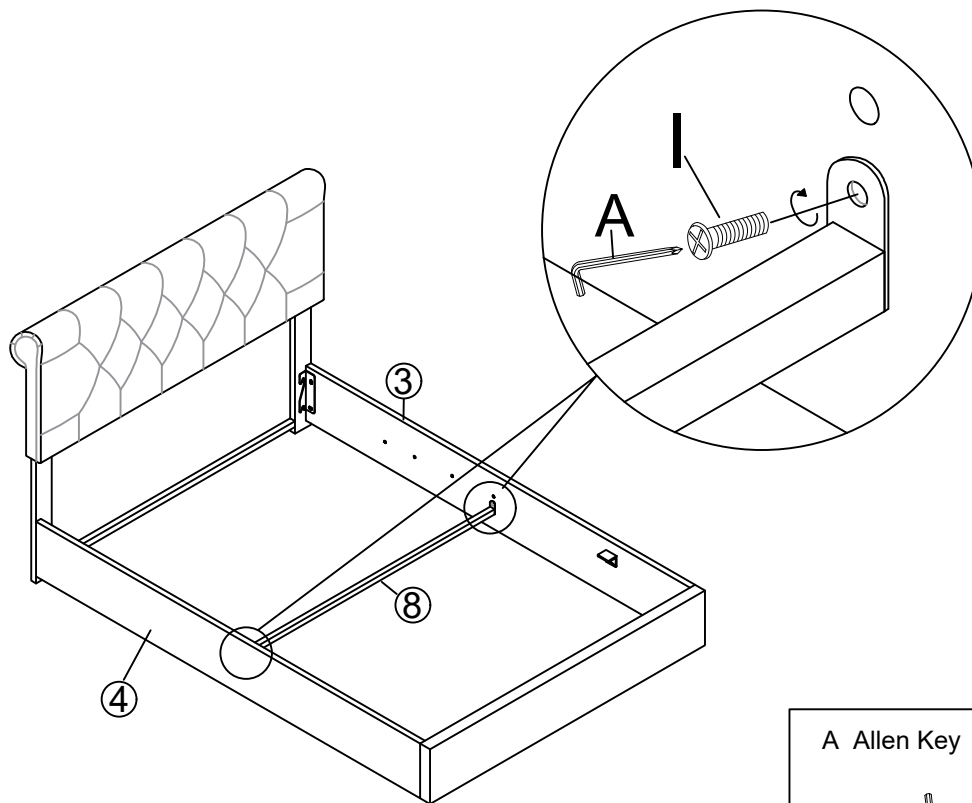

Step 5

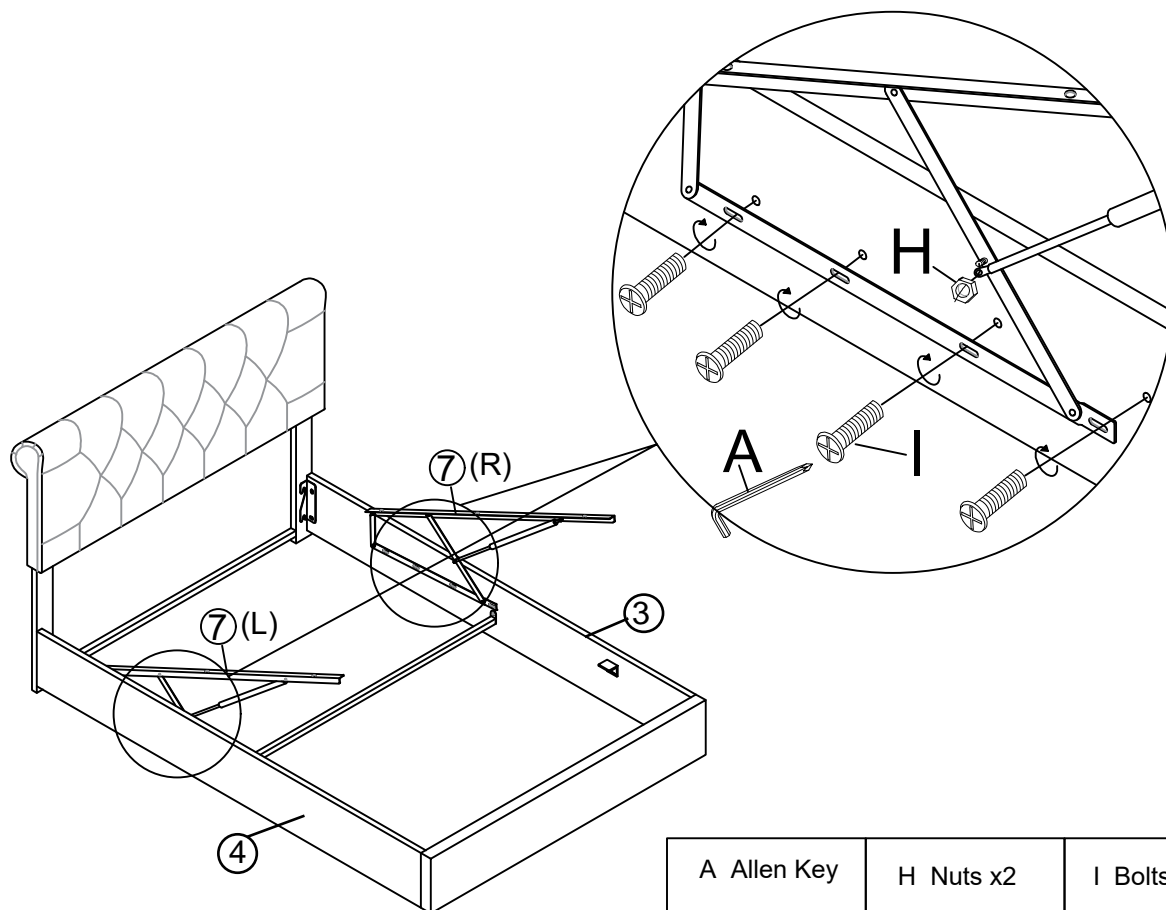

A Allen Key	I Bolts x 2
	
	M6X25mm

Step 6x2



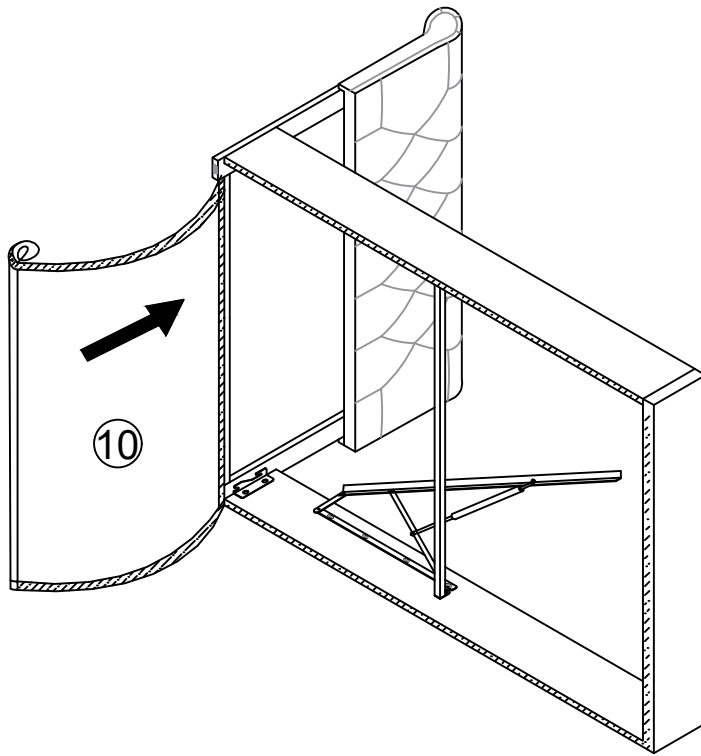

A Allen Key	H Nuts x2	I Bolts x 8
		
		M6X25mm

Step 7



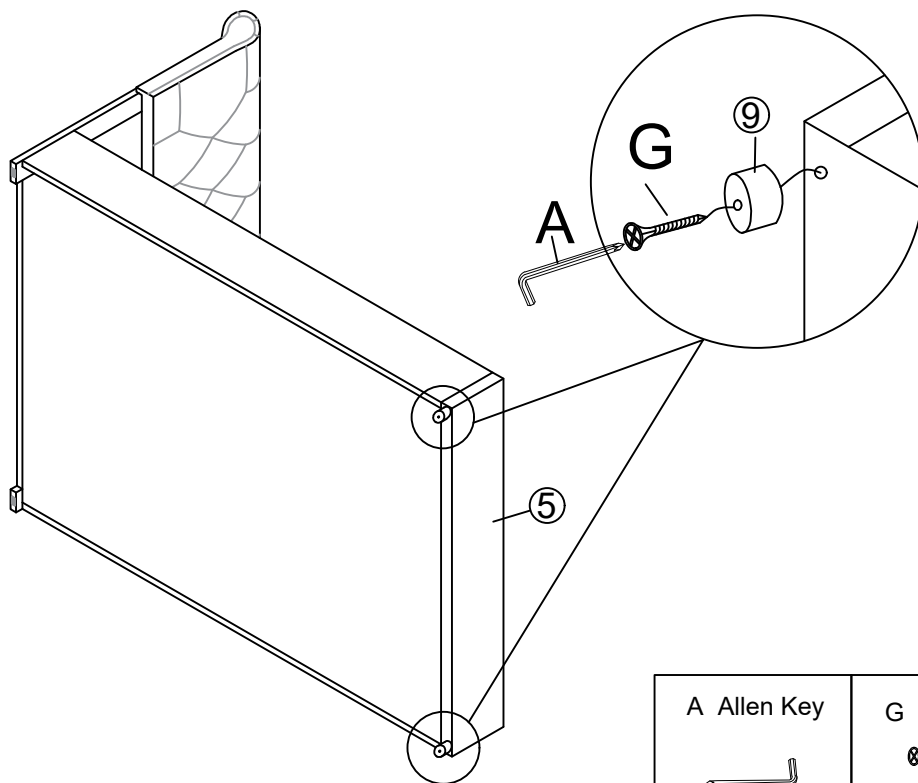



Step 8x2

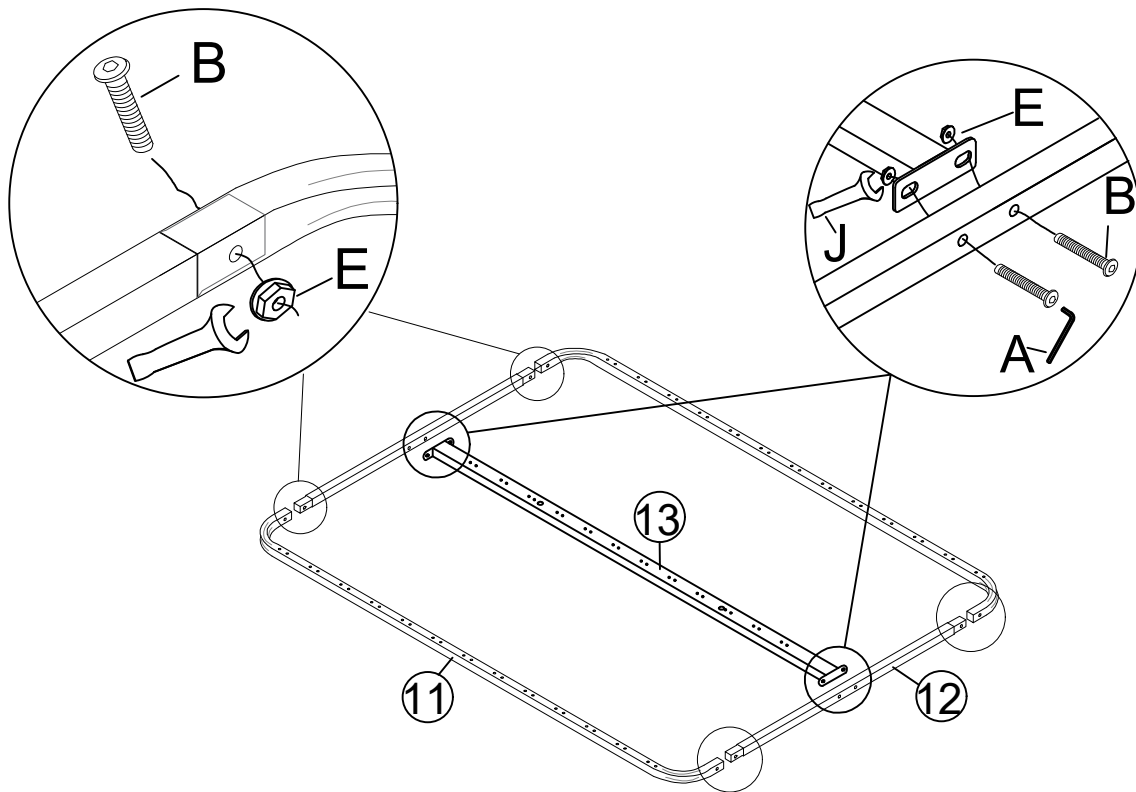

A Allen Key	G Nails x2
	
	M4X50mm



Step 9

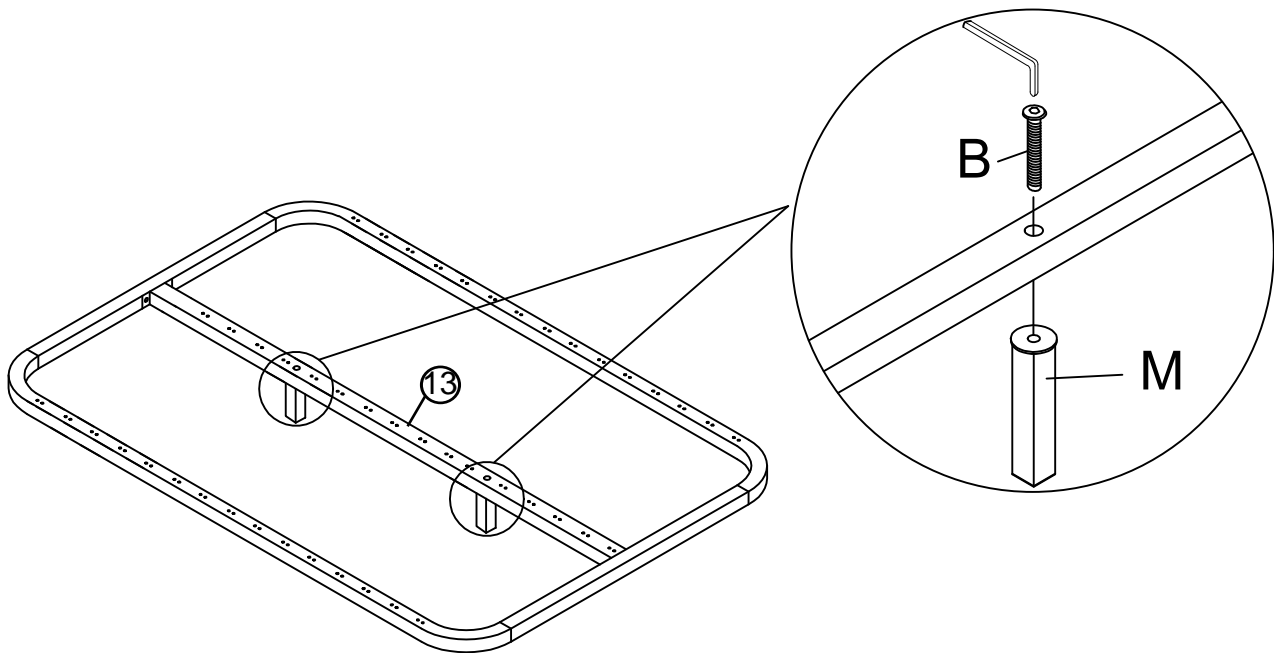

A Allen Key 	B Bolts x8  M8X45mm	E Nuts x8 	J Spanner x1 
---	--	---	--

Step 10 x2



A Allen Key 	B Bolts x 2  M8X45mm	M Middle legs x2 
--	--	--

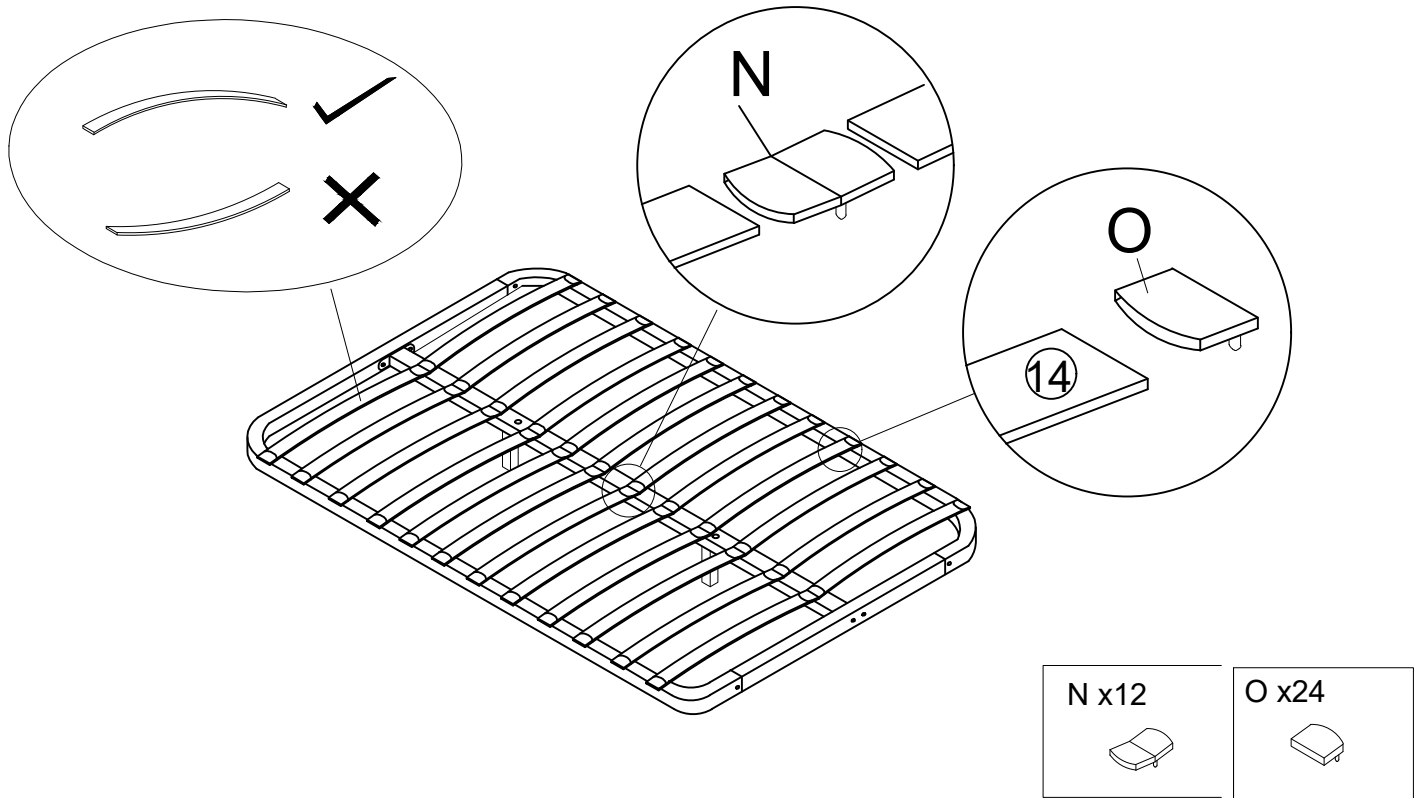

Step 11

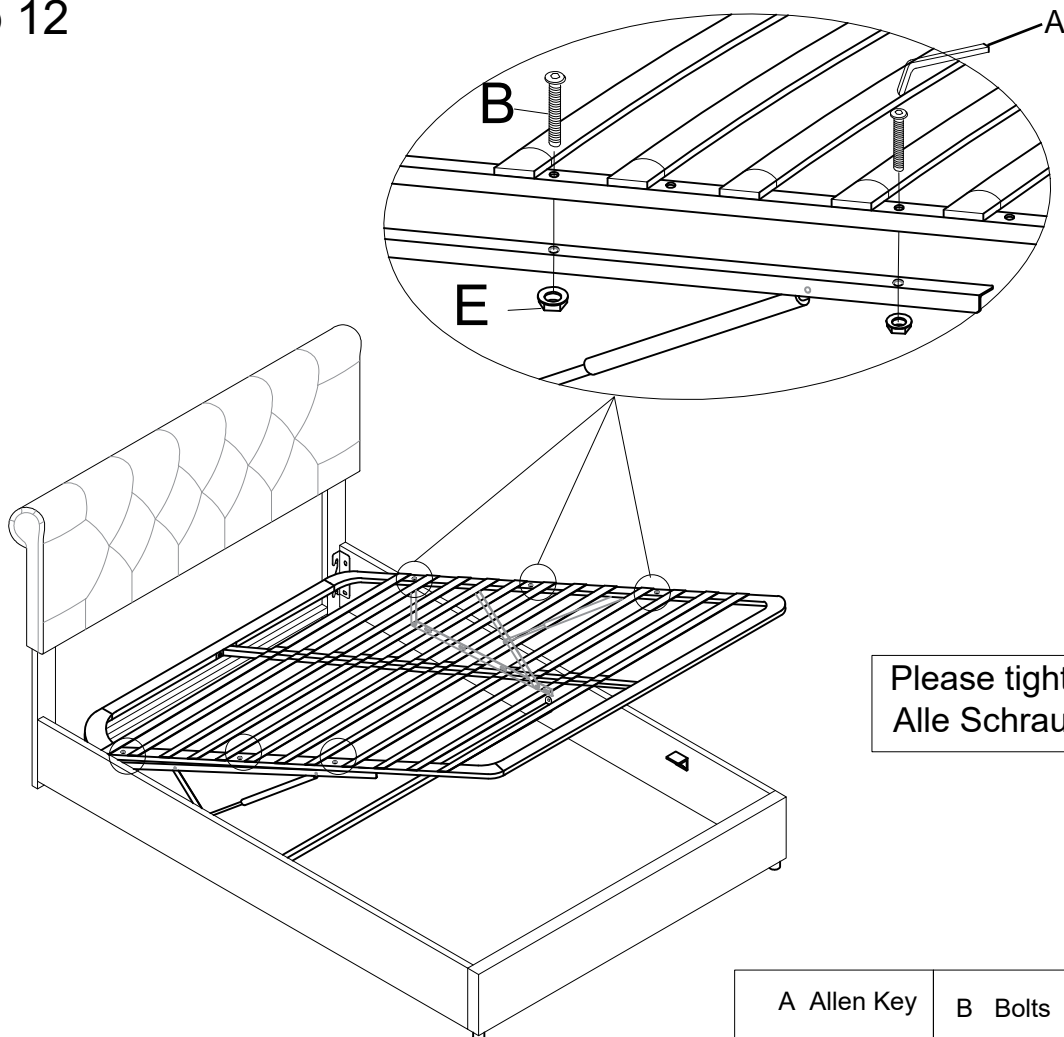

Step 12



Please tighten all screws.
Alle Schrauben anziehen.

<p>A Allen Key</p> 	<p>B Bolts x6</p>  <p>M8X45mm</p>	<p>E Nuts x6</p> 
---	--	--

Step 13

