

MONTAGEANLEITUNG/INSTRUCTIONS DE MONTAGE/ /ASSEMBLY INSTRUCTION

Artikelnummer/Item Number:

N622P373570W

N622P373571W

N622P373572W

Dieses Set ist in 3 Boxen enthalten. Wenn Sie keine vollen 3 Boxen erhalten wenden Sie sich bitte an unseren Kundenservice.

This set comes in 3 boxes. If you do not receive a full 3 boxes, please contact our customer service

CHALKTALE TWIN LOFT BED 200 x 90cm

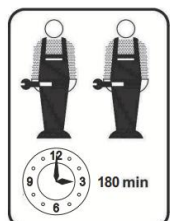
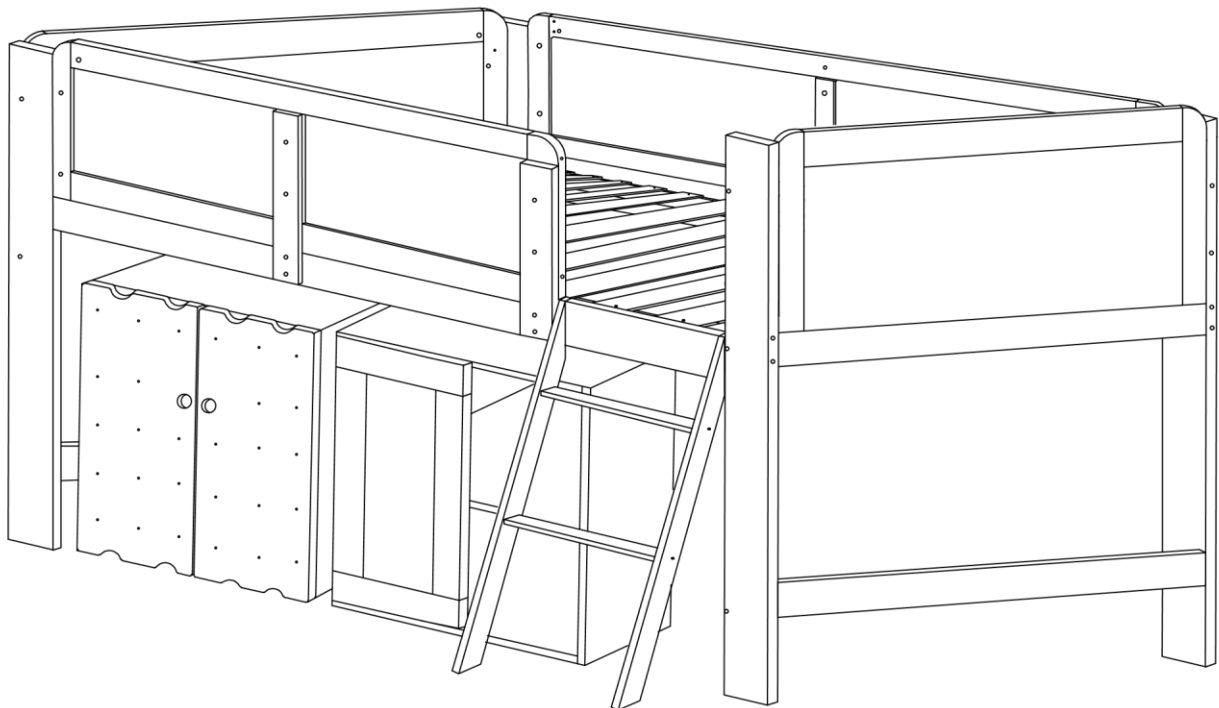

English

IMPORTANT ! KEEP FOR FUTURE REFERENCE : READ CAREFULLY

- To be assembled by an adult. Assembly must be checked by an adult before use
- WARNING ! Keep all screws, small parts and plastic bags out of the reach of children
- Properly identify all parts before assembling
- Never use your item if any of its parts are broken or missing
- Should any problems arise, please contact our After Sales Service
- Manufacturer's instructions shall be followed at all times
- Care: Clean with a soft, dry cloth. In case of larger stains, carefully rub with a slightly damp, non-abrasive sponge
- Avoid the risk of fire by not placing furniture near sources of ignition or hot items
- Do not jump on the bed

Deutsch

WICHTIG ! ZUM SPÄTEREN NACHSCHLAGEN AUFBEWAHREN: SORGFÄLTIG LESEN

- Muss von einem Erwachsenen zusammengebaut werden. Der Zusammenbau muss vor dem Gebrauch von einem Erwachsenen überprüft werden
- WARNUNG! Bewahren Sie alle Schrauben, Kleinteile und Plastikbeutel außerhalb der Reichweite von Kindern auf
- Kennzeichnen Sie vor dem Zusammenbau alle Teile richtig
- Benutzen Sie Ihren Artikel niemals, wenn Teile gebrochen sind oder fehlen
- Sollten Probleme auftreten, wenden Sie sich bitte an unseren Kundendienst
- Die Anweisungen des Herstellers sind stets zu befolgen
- Pflege: Mit einem weichen, trockenen Tuch reinigen. Bei größeren Flecken vorsichtig mit einem leicht feuchten, nicht scheuernden Schwamm abreiben. nicht scheuernden Schwamm
- Vermeiden Sie die Gefahr eines Brandes, indem Sie die Möbel nicht in der Nähe von Zündquellen oder heißen Gegenständen aufstellen
- Nicht auf das Bett springen

Français

IMPORTANT ! CONSERVER POUR RÉFÉRENCE ULTÉRIEURE : LIRE ATTENTIVEMENT

- Le montage doit être effectué par un adulte. Le montage doit être vérifié par un adulte avant Utilisation
- ATTENTION ! Tenir les vis, les petites pièces et les sachets en plastique hors de portée des enfants
- Identifiez correctement toutes les pièces avant de les assembler
- N'utilisez jamais votre article si l'une de ses pièces est cassée ou manquante
- En cas de problème, veuillez contacter notre service après-vente
- Les instructions du fabricant doivent être respectées à tout moment
- Entretien : nettoyer avec un chiffon doux et sec. En cas de taches plus importantes, frotter soigneusement avec une éponge non abrasive légèrement humide. légèrement humide et non Abrasive
- Évitez les risques d'incendie en ne plaçant pas les meubles à proximité de sources d'inflammation ou d'objets chauds
- Ne pas sauter sur le lit

Italiano

IMPORTANTE! CONSERVARE PER RIFERIMENTO FUTURO: LEGGERE ATTENTAMENTE

- Deve essere assemblato da un adulto. L'assemblaggio deve essere controllato da un adulto prima dell'uso
- **ATTENZIONE!** Tenere tutte le viti, le piccole parti e i sacchetti di plastica fuori dalla portata dei bambini
- Identificare correttamente tutte le parti prima dell'assemblaggio
- Non utilizzare mai l'articolo se alcune parti sono rotte o mancanti
- In caso di problemi, si prega di contattare il nostro Servizio Post Vendita
- Le istruzioni del produttore devono essere sempre seguite
- Cura: Pulire con un panno morbido e asciutto. In caso di macchie più estese, strofinare accuratamente con una spugna leggermente umida e nonspugna leggermente umida e non abrasiva
- Evitare il rischio di incendio, non collocando i mobili vicino a fonti di accensione o a oggetti caldi
- Non saltare sul letto

Español

¡ IMPORTANTE ! CONSERVELO PARA FUTURAS CONSULTAS: LEA ATENTAMENTE

- Debe ser montado por un adulto. El montaje debe ser comprobado por un adulto antes del uso
- ADVERTENCIA Mantenga todos los tornillos, piezas pequeñas y bolsas de plástico fuera del alcance de los niños.
- Identifique correctamente todas las piezas antes de montarlas
 - Nunca utilice su artículo si alguna de sus piezas está rota o falta
 - Si surge algún problema, póngase en contacto con nuestro Servicio Postventa
 - Las instrucciones del fabricante deben seguirse en todo momento
 - Cuidado: Limpiar con un paño suave y seco. En caso de manchas más grandes, frote cuidadosamente con una esponja no abrasiva ligeramente humedecida.
 - Evite el riesgo de incendio no colocando los muebles cerca de fuentes de ignición u objetos calientes.
 - No saltar sobre la cama.

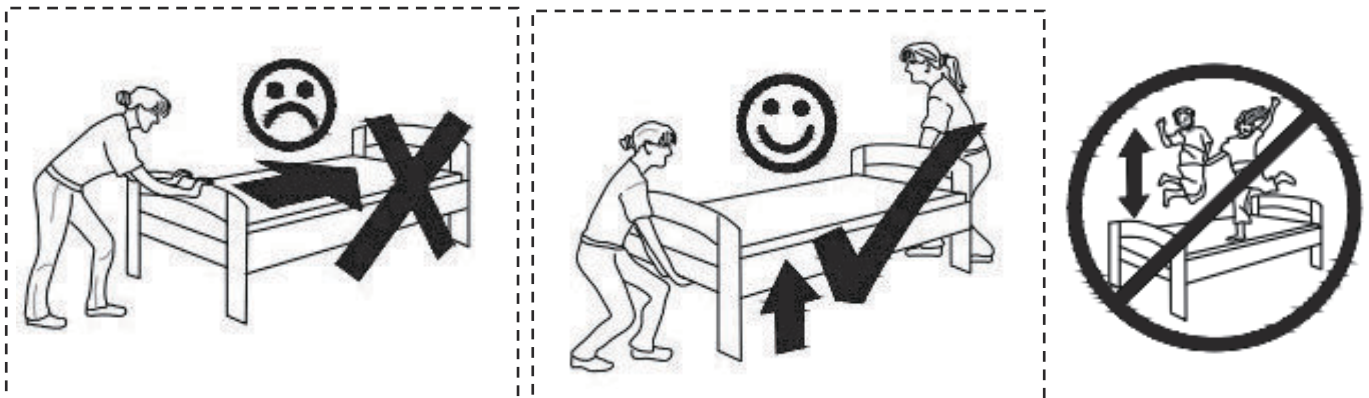

INSTRUCTIONS

IMPORTANT-READ CAREFULLY-RETAIN FOR FUTURE REFERENCE

- A) WARNING** -Children can become trapped between the bed and the wall, the adjoining pieces of furniture (e.g. cupboards) and the gap. To avoid risk of serious injury the distance between the safety barrier and the adjoining structure shall not exceed 7.5cm or shall be more than 23cm.
- B) WARNING** -Do not use the bed if any structural part is broken or missing; Replacement parts are between requested from the manufacturer or the store.
- C) WARNING** -Do not climb or wiggle on any non-designated structures.
- D) WARNING** -Product must be attached to wall or building structure. Always follow the manufacturer's instructions.
- E) WARNING** -The upper bed is not suitable for children under six years due to the risk of injury from falls.
- F) WARNING** -Bunk beds / high beds can present a serious risk of injury from strangulation if not used correctly. Never attach or hang items to any part of the bunk bed / high bed that are not designed to be used with the bed, for example, but not limited to ropes, strings, cords, hooks, belts and bags
- G) The recommended size of the mattress to be used with the bed is **200X90cm**, maximum thickness mattress: **14cm**.**
- H) It is necessary to ventilate the room in order to maintain a low level moisture and prevent mold growth in the bed and its periphery.**
- I) Joining devices should always be tightened properly and regularly verified. Tighten if necessary.**
- J) Meets European standard requirements NC safety **EN 747-1:2024**.**

ANLEITUNGEN

WICHTIG - SORGFÄLTIG LESEN - FÜR SPÄTERE VERWENDUNG AUFBEWAHREN

- A) WARNUNG** - Kinder können zwischen dem Bett und der Wand, den angrenzenden Möbelstücken (z.B. Schränken) und dem Ike eingeklemmt werden. Um das Risiko schwerer Verletzungen zu vermeiden, darf der Abstand zwischen der Sicherheitsbarriere und der angrenzenden Struktur 7.5 cm nicht überschreiten oder mehr als 23 cm betragen.
- B) WARNUNG** - Verwenden Sie das Bett nicht, wenn ein strukturelles Teil beschädigt oder fehlt; Ersatzteile sind beim Hersteller oder im Geschäft anzufordern.
- C) WARNUNG** - Klettern oder Wackeln auf nicht dafür vorgesehenen Strukturen ist untersagt.
- D) WARNUNG** -Das Produkt muss an der Wand oder der Gebäudestruktur befestigt werden. Befolgen Sie immer die Anweisungen des Herstellers.
- E) WARNUNG** - Das obere Bett ist nicht für Kinder unter sechs Jahren geeignet, da Verletzungsgefahr durch Stürze besteht.
- F) WARNUNG** - Etagenbetten / Hochbetten können ein ernsthaftes Verletzungsrisiko durch Erstickung darstellen, wenn sie nicht richtig verwendet werden. Befestigen oder hängen Sie niemals Gegenstände an irgendeinen Teil des Etagenbettes / Hochbettes, die nicht dafür vorgesehen sind, zum Beispiel, aber nicht beschränkt auf Seile, Schnüre, Kordeln, Haken, Gürtel und Taschen.
- G) Die empfohlene Größe der Matratze, die mit dem Bett verwendet werden soll, beträgt **200X90cm**, maximale Matratzenstärke: **14cm**.**
- H) Es ist notwendig, den Raum zu belüften, um ein niedriges Feuchtigkeitsniveau aufrechtzuerhalten und Schimmelbildung im Bett und dessen Umgebung zu verhindern.**
- I) Verbindungselemente sollten immer ordnungsgemäß angezogen und regelmäßig überprüft werden. Bei Bedarf anziehen.**
- J) Entspricht den europäischen Normanforderungen NC-Sicherheit **EN 747-1:2024**.**



DE: Vor dem Einbau die Schrauben in die Löcher stecken und festziehen, aber nicht bis 100%, 70% bis 80% anziehen reicht aus. Schließlich, nachdem alle Schrauben installiert sind, ziehen Sie alle Schrauben auf 100%.

Wenn Sie auf diese Probleme stoßen, wie z. B. Fehlausrichtung der Löcher oder Unfähigkeit, bestimmte Teile zu installieren, überprüfen Sie bitte, ob die Schrauben korrekt verwendet werden und passen Sie die Dichtigkeit der Schrauben an.

UK: Before installation, insert the screws into the holes and tighten them, but do not tighten them to 100%, 70% to 80% is sufficient. Finally, after all screws are installed, tighten all screws to 100%.

If you encounter these issues, such as if the holes cannot be aligned or some parts cannot be installed, please check if the screws are used correctly and adjust the tightness of the screws.

FR: Insérer la vis dans le trou avant la fin de l'assemblage, serrer la vis, mais ne pas serrer à 100%, 70% ~ 80% est correct. Enfin, une fois que toutes les vis sont bien serrées, toutes les vis sont serrées à 100%.

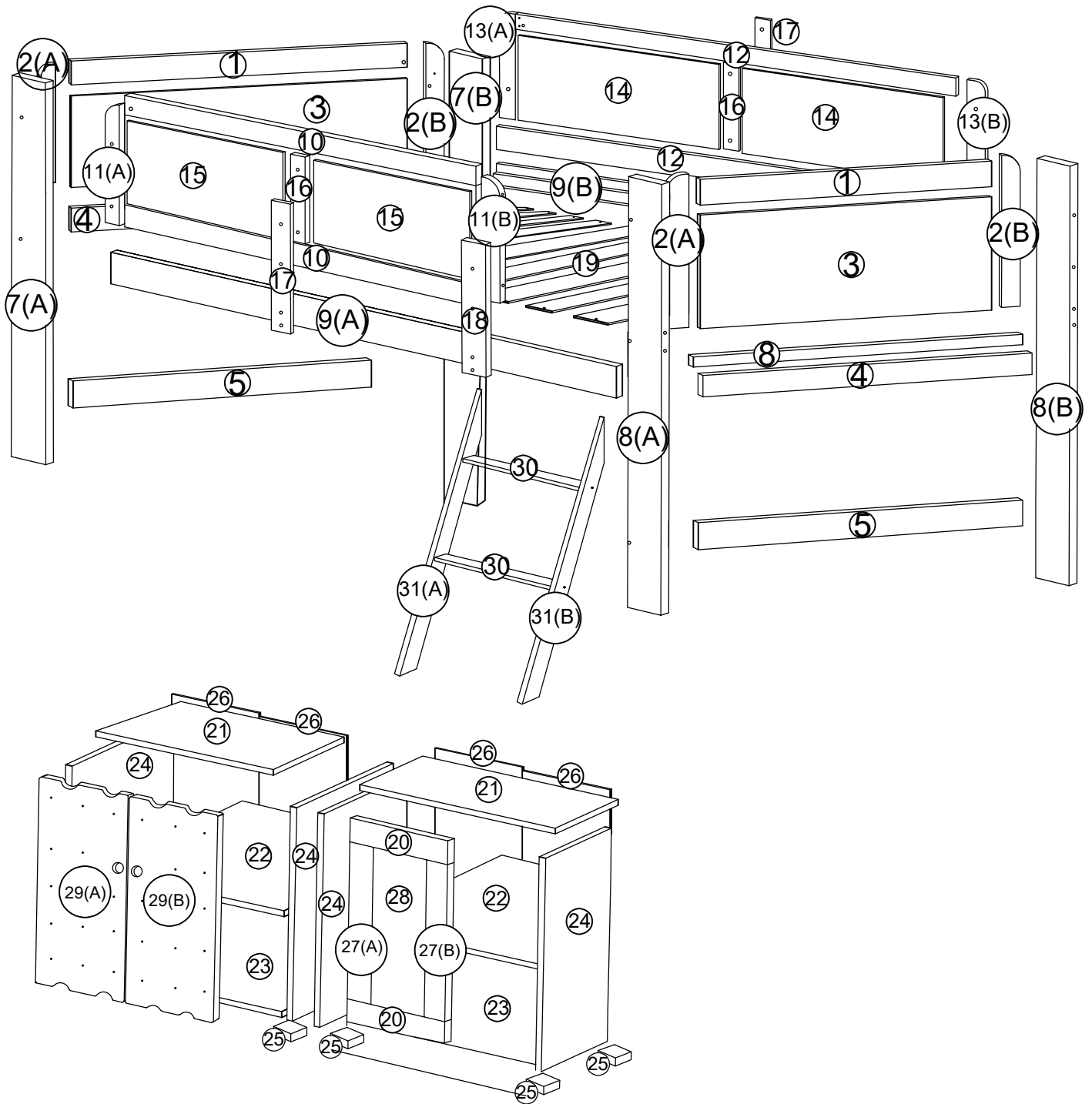

Si vous rencontrez ces problèmes, par exemple si les trous ne sont pas alignés ou si certaines pièces ne peuvent pas être montées, vérifiez que les vis sont utilisées correctement et ajustez leur serrage.

STUKLISTE

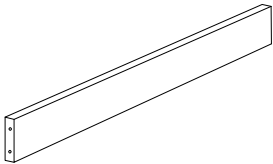
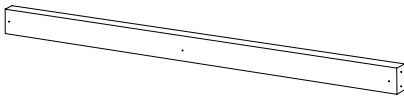
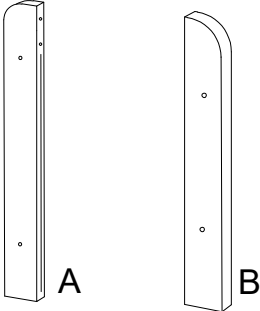
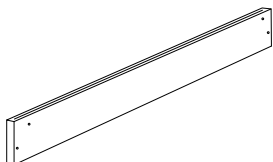
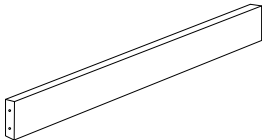
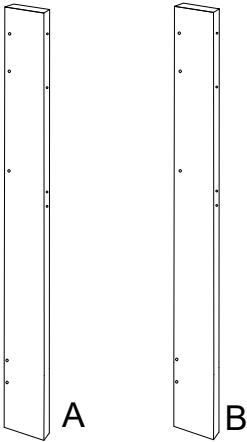

ASSEMBLY INSTRUCTION/INSTRUCTIONS DE MONTAGE/ ASSEMBLERGEFEHL

N622P373570W

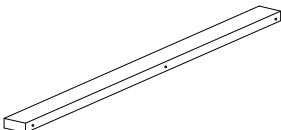
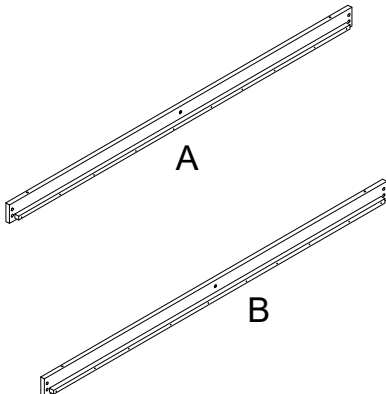
<p>1</p>  <p>SIDE PANEL - 2 PCS SEITENPANEL - 2 STK PANNEAU LATÉRAL - 2 PCS</p>	<p>10</p>  <p>FRONT GUARD RAIL - 2 PCS VORDERER SCHUTZBALKEN - 2 STK BARRE DE GARDE AVANT - 2 PCS</p>	<p>11</p>  <p>GUARDRAIL SUPPORT - 2 PCS BARRIEREUNTERSTÜTZUNG - 2 STK SOUTIEN DE GARDRAIL - 2 PCS</p>
<p>4</p>  <p>SIDE PANEL - 2 PCS SEITENPANNEL - 2 STK PANNEAU LATÉRAL - 2 PCS</p>	<p>5</p>  <p>DOWN SIDE PANEL - 2 PCS UNTERE SEITENANZEIGE - 2 STK PANEL LATÉRAL INFÉRIEUR - 2 PCS</p>	<p>6</p>  <p>POST - 2 PCS PAAL - 2 PCS POTEAU - 2 PCS</p>
<p>7</p>  <p>POST - 2 PCS PAAL - 2 PCS POTEAU - 2 PCS</p>	<p>8</p>  <p>SUPPORT SIDE PANEL - 2 PCS UNTERSTÜTZUNGSSEITENFENSTER - 2 STK PANNEAU LATÉRAL DE SUPPORT - 2 PCS</p>	<p>9</p>  <p>FRONT GUARD RAIL - 2 PCS VOORSTE SCHUIFRAIL - 2 STK LISSE AVANT - 2 PCS</p>

ASSEMBLY INSTRUCTION/INSTRUCTIONS DE MONTAGE/ ASSEMBLERGEFEHL

N622P373570W

33

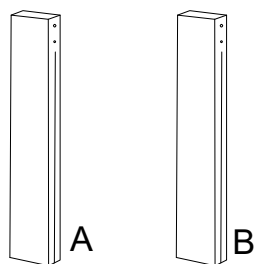

DOOR SIDE SUPPORT - 2 PCS
TÜRENBEREICHHILFE - 2 STK
SOUTIEN DE CÔTÉ DE PORTE - 2 PCS

12

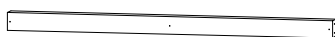

BACK GUARD RAIL - 2 PCS
ACHTERSTE SCHUIFRAIL - 2 STK
LISSE ARRIÈRE - 2 PCS

20



DOOR FRONT SUPPORT - 2 PCS
VORDERER TÜRSUPPORT - 2 STK
SOUTIEN DE PORTE D'ENTRÉE - 2 PCS

17



GUARD RAIL SUPPORT - 2 PCS
BARRIEREHALTERUNG - 2 STK
SOUTIEN DE GRADE DE GARDE - 2 PCS

16



FRONT VERTICAL RAIL - 2 PCS
VERTICALE RAIL VOORAAN - 2 STK
RAIL VERTICAL AVANT - 2 PCS

18

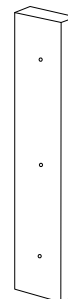

SIDE SUPPORT - 1 PC
SEITENUNTERSTÜTZUNG - 1 STK
SOUTIEN LATERAL - 1 PC

ASSEMBLY INSTRUCTION/INSTRUCTIONS DE MONTAGE/ ASSEMBLERGEFEHL

N622P373571W

21

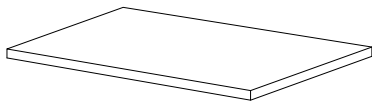

DRAWER TOP - 2 PCS
OBERER SCHUBLADEN - 2 STK
TIROIR DU HAUTPCS - 2 PCS

22

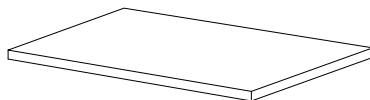

DRAWER MIDDLE PANEL - 2 PCS
MITTELPANEL DES SCHUBFACHES - 2 STK
PANNEAU CENTRAL DU TIROIR - 2 PCS

23

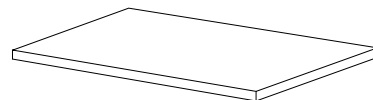

DRAWER BOTTOM PANEL - 2 PCS
SCHUBLADENBODENPLATTE- 2 STK
PANNEAU INFÉRIEUR DU TIROIR - 2 PCS

24

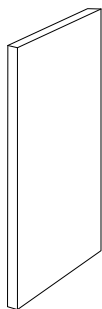

DRAWER SIDE POST - 4 PCS
SCHUBLADENSEITENPFOSTEN - 4 STK
PILIERS DE TIROIR - 4 PCS

26

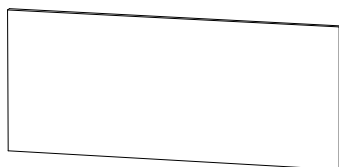

DRAWER BACK BLACK BOARD PANEL - 4 PCS
ZIEHEN SIE DAS SCHWARZE TAFELPANEL
ZURÜCK - 4 PCS
PANEL DE DOS NOIR DU TIROIR - 4 PCS

25



DRAWER DOWN POST - 8 PCS
SCHUBLADEN HERUNTER BEITRAG - 8 STK
TIROIR DESCENDRE POSTE - 8 PCS

ASSEMBLY INSTRUCTION/INSTRUCTIONS DE MONTAGE/ ASSEMBLERGEFEHL

N622P373572W

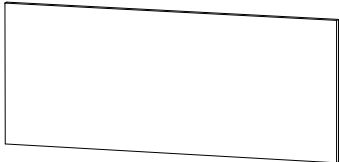
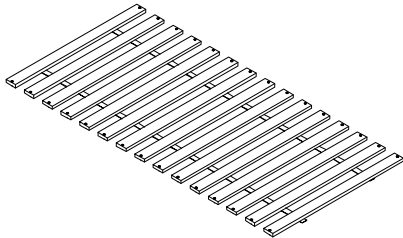
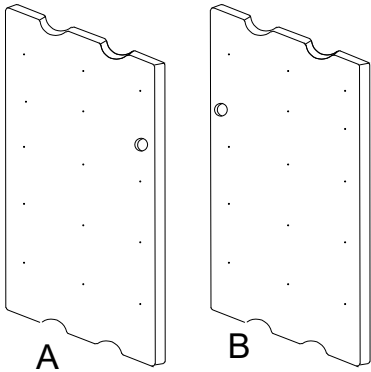
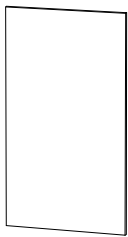
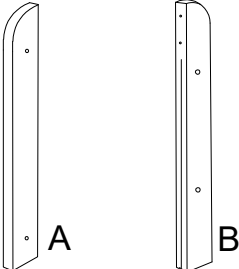
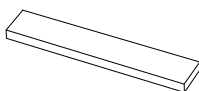
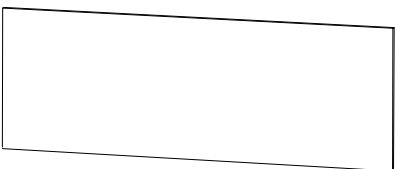
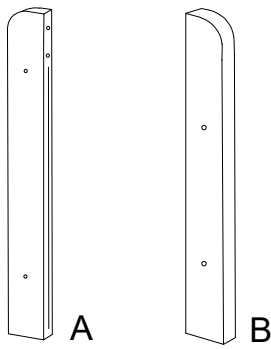
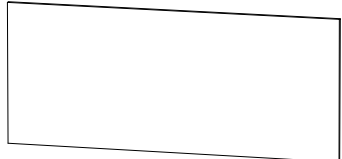
<p>3</p>  <p>SIDE PANEL - 2 PCS SEITENPANNE - 2 STK PANEL LATÉRAL - 2 PCS</p>	<p>19</p>  <p>SLAT - 1 SET LATTEN - 1SET LAMES - 1JEU</p>	<p>29</p>  <p>DRAWER DOOR - 2 PCS SCHUBLADENTUR - 2 STK PORTE DE TOROIR - 2 PCS</p>
<p>28</p>  <p>DRAWER PANEL - 1 PC SCHUBLADENPANNE - 1 STK PANNEAU DE TIROIR - 1 PC</p>	<p>2</p>  <p>PANEL SUPPORT LEFT - 4 PCS PANEL SUPPORT LINKS - 4 STK SOUTIEN DU PANNEAU GAUCHE - 4 PCS</p>	<p>30</p>  <p>LADDER STEP - 2 PCS LADDERTREDEN - 2 STK MARCHEPIED - 2 PCS</p>
<p>14</p>  <p>BACK PANEL - 2 PCS RÜCKSEITE - 2 STK PANEL ARRIÈRE - 2 PCS</p>	<p>13</p>  <p>BACK GUARDRAIL SUPPORT - 2 PCS BARRIEREUNTERSTÜTZUNG - 2 STK SOUTIEN DE GARDRAIL - 2 PCS</p>	<p>15</p>  <p>FRONT PANEL - 2 PCS VORDERSEITE - 2 STK PANNEAU AVANT - 2 PCS</p>

ASSEMBLY INSTRUCTION/INSTRUCTIONS DE MONTAGE/ ASSEMBLERGEFEHL

N622P373572W

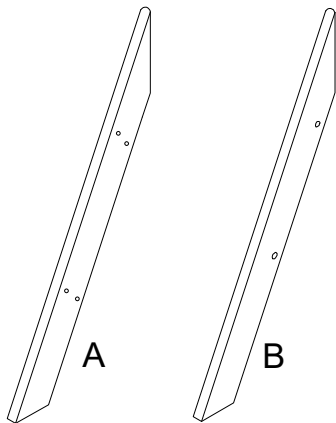

31



LADDER SIDE - 2 PCS
LADDERZIJDE - 2 STK
CÔTÉ ÉCHELLE - 2 PCS

ASSEMBLY INSTRUCTION/INSTRUCTIONS DE MONTAGE/ ASSEMBLERGEFEHL

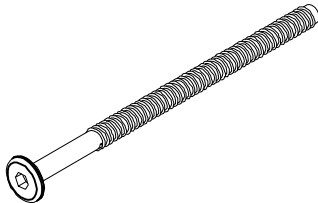
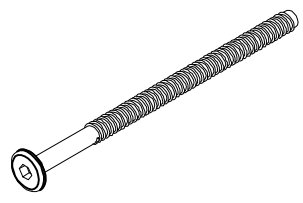
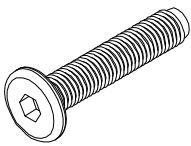
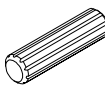
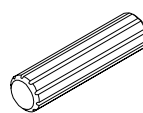
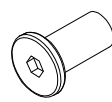
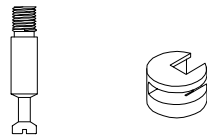
N622P373571W

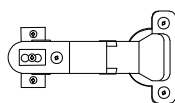
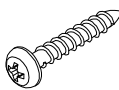
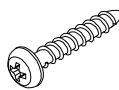
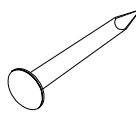
<p>A</p>  <p>JCBC BOLT M6 x 100MM - 18PCS JCBC BOLT M6 x 100MM - 18STK JCBC BOLT M6 x 100MM - 18PCS</p>	<p>B</p>  <p>JCBC BOLT M6 x 60MM - 20PCS JCBC BOLT M6 x 60MM - 20STK JCBC BOLT M6 x 60MM - 20PCS</p>	<p>C</p>  <p>JCBC BOLT M6 x 30MM - 12PCS JCBC BOLT M6 x 30MM - 12STK JCBC BOLT M6 x 30MM - 12PCS</p>
<p>D</p>  <p>DOWEL M8 x 30MM - 20PCS PEN M8 X 30MM - 20STK GOUJON M8 X 30MM - 8PCS</p>	<p>E</p>  <p>DOWEL M10 x 40MM - 32PCS PEN M10 X 40MM - 32STK GOUJON M10 X 40MM - 32PCS</p>	<p>F</p>  <p>JCN NUT M6 - 12PCS JCN MUTTER M6 - 12STK ÉCROU G-JCN M6 - 12PCS</p>
<p>G</p>  <p>1 (A) 1 (B)</p> <p>MINI FIX M12 x 15MM - 12PCS MINI FIX M12 x 15MM - 12STK MINI FIX M12 x 15MM - 12PCS</p>	<p>H</p>  <p>BARREL NUT M6 - 44PCS FASSMUTTER M6 - 44STK ÉCROU EN H M6 - 44PCS</p>	<p>I</p>  <p>HINGES - 6PCS SCHARNIERE - 6PCS CHARNIÈRES - 6PCS</p>
<p>J</p>  <p>P/H SCREW M4 x 25MM - 30PCS PANHEAD-SCHRAUBE M4 x 25MM - 30STK VIS À TÊTE O M4 x 25MM - 38PCS</p>	<p>K</p>  <p>P/H SCREW M3.5 x 16MM - 24PCS PANHEAD-SCHRAUBE M3.5 x 16MM - 24STK VIS À TÊTE O M3.5 x 16MM - 24PCS</p>	<p>L</p>  <p>NAIL PIN 15MM - 36PCS NAIL PIN 15MM - 36STK PICOTS À ONGLES 15MM - 36PCS</p>

ASSEMBLY INSTRUCTION/INSTRUCTIONS DE MONTAGE/ ASSEMBLERGEFEHL

N622P373571W

M

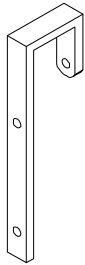

LADDER HOOK - 2 PCS
LADDERHAAK - 2STK
CROCHET D'ÉCHELLE - 2PCS

N

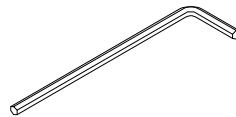

ALLEN KEY M5 - 1PCS
INBUSSLEUTEL M5 - 1STK
CLÉ ALLEN M5 - 1PCS

O

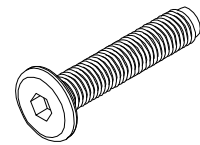

JCBC BOLT M6 x 20MM - 8PCS
JCBC BOLT M6 x 20MM - 8STK
JCBC BOLT M6 x 20MM - 8PCS

P

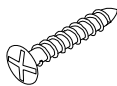

CSK SCREW M3.5 x 16MM - 6PCS
CSK SCHRAUBE M3.5 x 16MM - 6STK
Vis CSK M3.5 x 16MM - 6PCS

Q

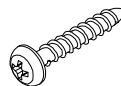

P/H SCREW M4 x 32MM - 6PCS
PANHEAD-SCHRAUBE M4 x 32MM - 6STK
VIS À TÊTE O M4 x 32MM - 6PCS

R



1 (A)



1 (B)

MINI FIX M8.5 x 15MM - 24SET
MINI FIX M8.5 x 15MM - 24STK
MINI FIX M8.5 x 15MM - 24SET

S

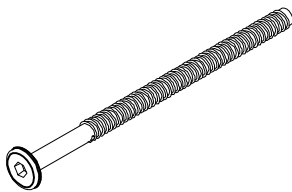

JCBC BOLT M6 x 110MM - 8PCS
JCBC BOLT M6 x 110MM - 8STK
JCBC BOLT M6 x 110MM - 8PCS

ASSEMBLY INSTRUCTION/INSTRUCTIONS DE MONTAGE/ ASSEMBLERGEFEHL

STEP 1 LEFT

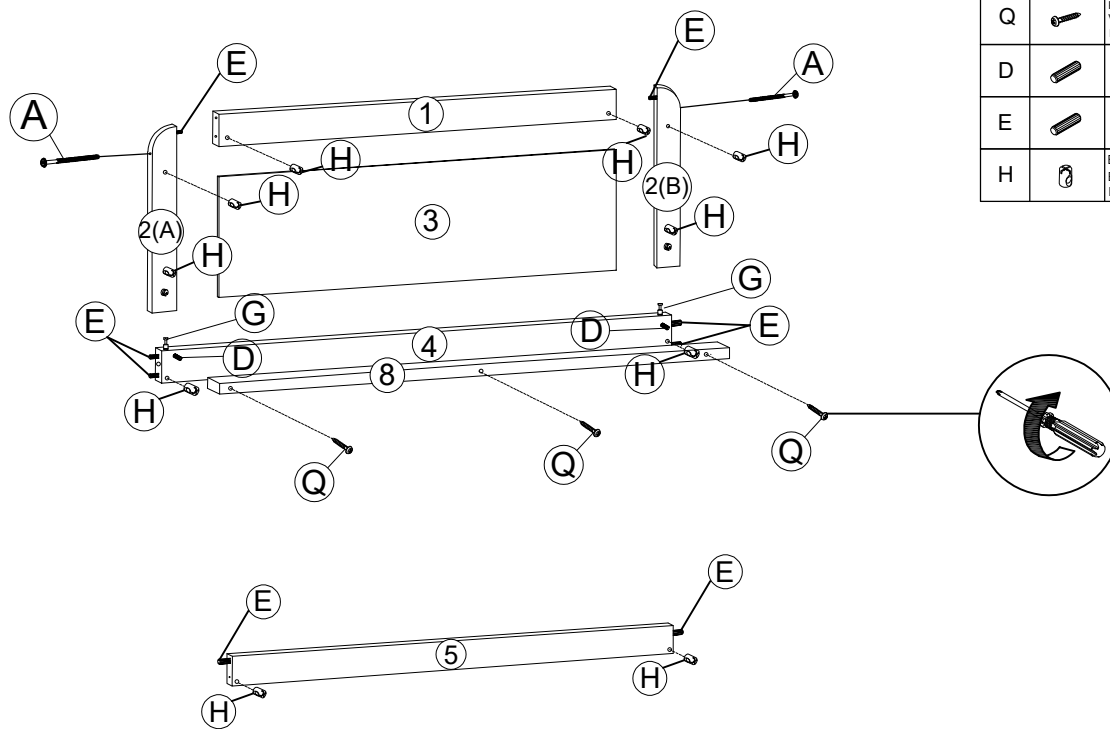

A		JCBC M6 x 100 MM JCBC M6 x 100 MM JCBC M6 x 100 MM	2
G		MINI FIX M12 x 16 MM GOUPILLE À CLOU 15MM NAGELNADEL 15MM	2
Q		PANHEAD SCREW M4 x 32 MM VIS PANHEAD M4 x 32 MM LINSENKOPF-SCHRAUBE M4 x 32 MM	3
D		DOWEL M8 x 30 MM CHEVILLE EN BOIS M8 x 30 MM HOLZ-DÜBEL M8 x 30 MM	2
E		DOWEL M10 x 40 MM CHEVILLE EN BOIS M10 x 40 MM HOLZ-DÜBEL M10 x 40 MM	8
H		BARREL NUT M6 x 15 MM ÉCROU DE BARILLET M6 x 15 MM LAUFMUTTER M6 x 15 MM	10

STEP 2 RIGHT

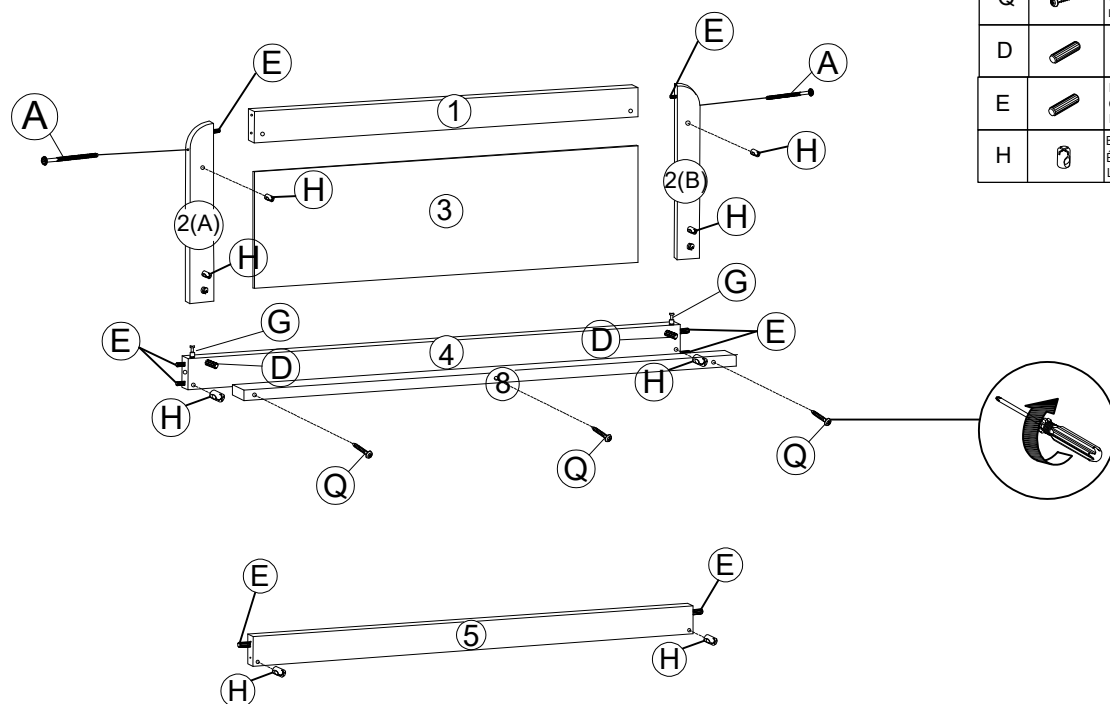

A		JCBC M6 x 100 MM JCBC M6 x 100 MM JCBC M6 x 100 MM	2
G		MINI FIX M12 x 16 MM GOUPILLE À CLOU 15MM NAGELNADEL 15MM	2
Q		PANHEAD SCREW M4 x 32 MM VIS PANHEAD M4 x 32 MM LINSENKOPF-SCHRAUBE M4 x 32 MM	3
D		DOWEL M8 x 30 MM CHEVILLE EN BOIS M8 x 30 MM HOLZ-DÜBEL M8 x 30 MM	2
E		DOWEL M10 x 40 MM CHEVILLE EN BOIS M10 x 40 MM HOLZ-DÜBEL M10 x 40 MM	8
H		BARREL NUT M6 x 15 MM ÉCROU DE BARILLET M6 x 15 MM LAUFMUTTER M6 x 15 MM	10



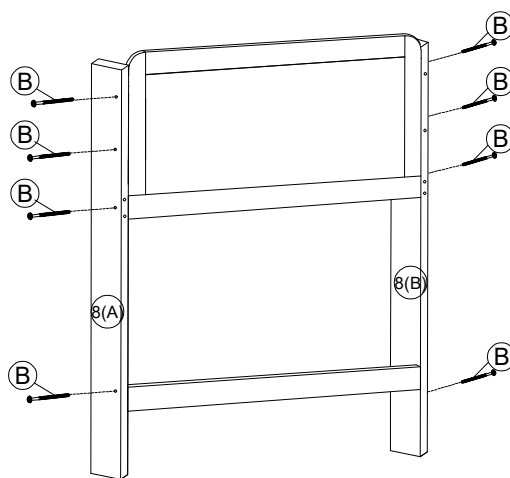
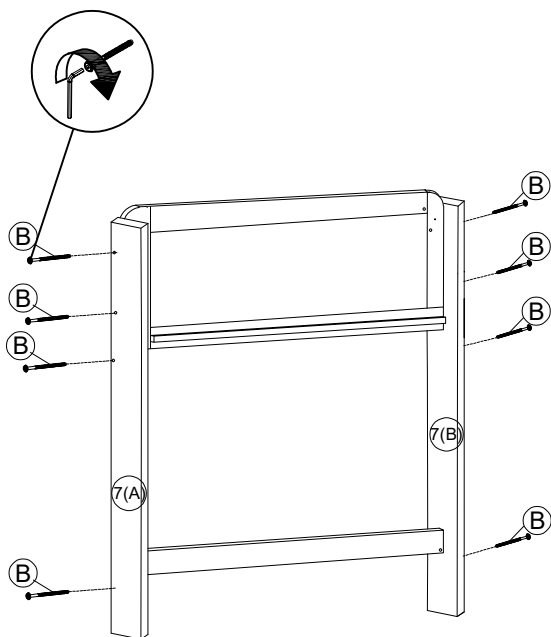

ASSEMBLY INSTRUCTION/INSTRUCTIONS DE MONTAGE/ ASSEMBLERGEFEHL

STEP 3

B		JCBC M6 x 60 MM JCBC M6 x 60 MM JCBC M6 x 60 MM	16
---	---	---	----





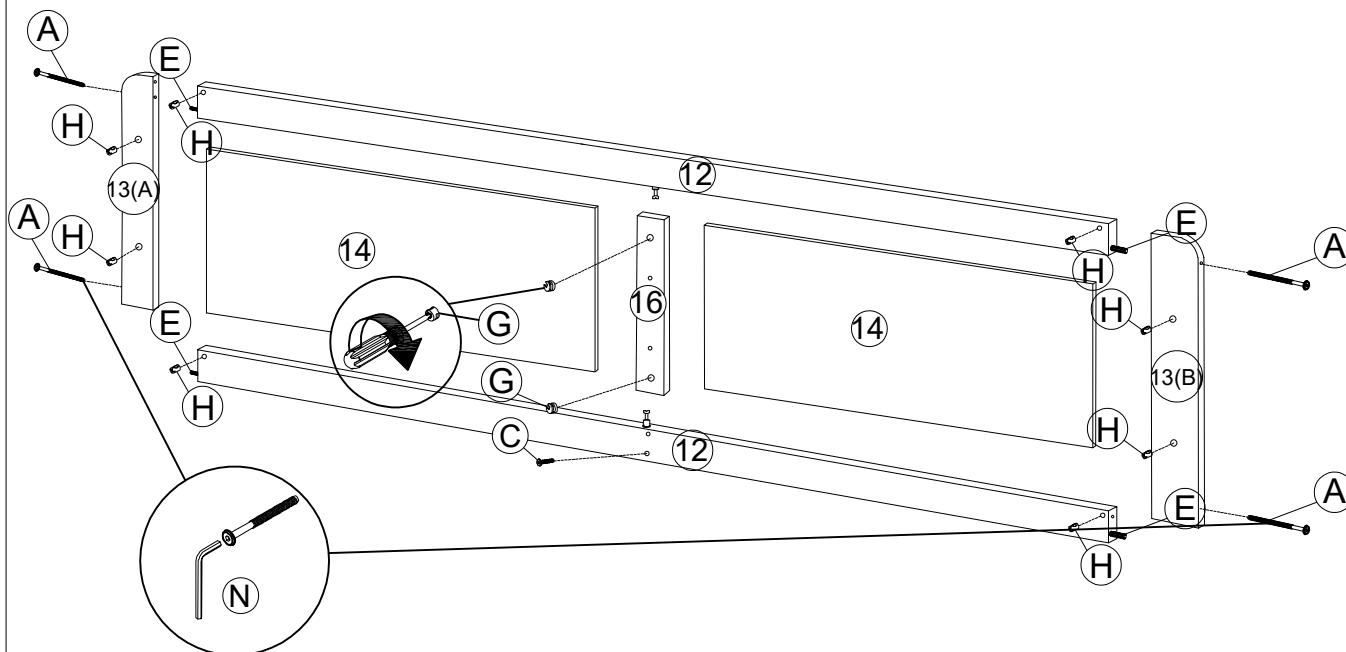

STEP 4 BACK

A		JCBC M6 x 100 MM JCBC M6 x 100 MM JCBC M6 x 100 MM	4
G		MINI FIX M12 x 16 MM GOUPILLE À CLOU 15MM NAGELNADEL 15MM	2
E		DOWEL M10 x 40 MM CHEVILLE EN BOIS M10 x 40 MM HOLZ-DÜBEL M10 x 40 MM	4
H		BARREL NUT M6 x 15 MM ÉCROU DE BARILLET M6 x 15 MM LAUFMUTTER M6 x 15 MM	8





ASSEMBLY INSTRUCTION/INSTRUCTIONS DE MONTAGE/ ASSEMBLERGEFEHL

STEP 5 FRONT

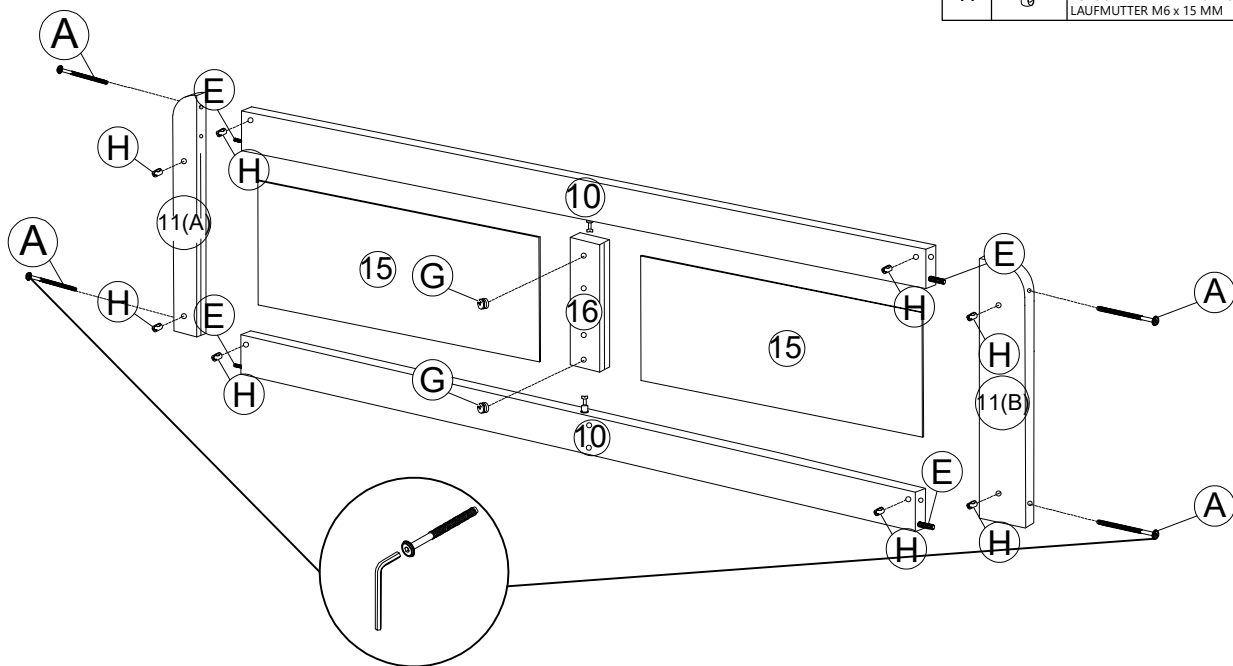
A		JCBC M6 x 100 MM JCBC M6 x 100 MM JCBC M6 x 100 MM	4
G		MINI FIX M12 x 16 MM GOUPILLE À CLOU 15MM NAGELNADEL 15MM	2
E		DOWEL M10 x 40 MM CHEVILLE EN BOIS M10 x 40 MM HOLZ-DÜBEL M10 x 40 MM	4
H		BARREL NUT M6 x 15 MM ÉCROU DE BARILLET M6 x 15 MM LAUFMUTTER M6 x 15 MM	8



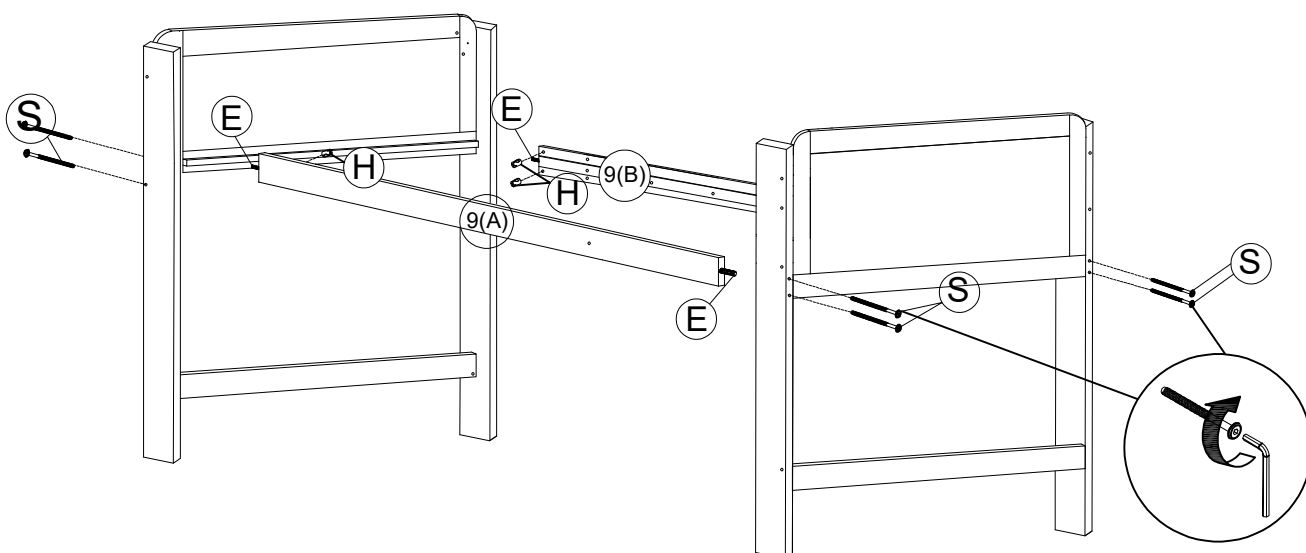

STEP 6 BACK

S		JCBC M6 x 110 MM JCBC M6 x 110 MM JCBC M6 x 110 MM	8
E		DOWEL M10 x 40 MM CHEVILLE EN BOIS M10 x 40 MM HOLZ-DÜBEL M10 x 40 MM	4
H		BARREL NUT M6 x 15 MM ÉCROU DE BARILLET M6 x 15 MM LAUFMUTTER M6 x 15 MM	8





ASSEMBLY INSTRUCTION/INSTRUCTIONS DE MONTAGE/ ASSEMBLERGEFEHL

STEP 7 FRONT

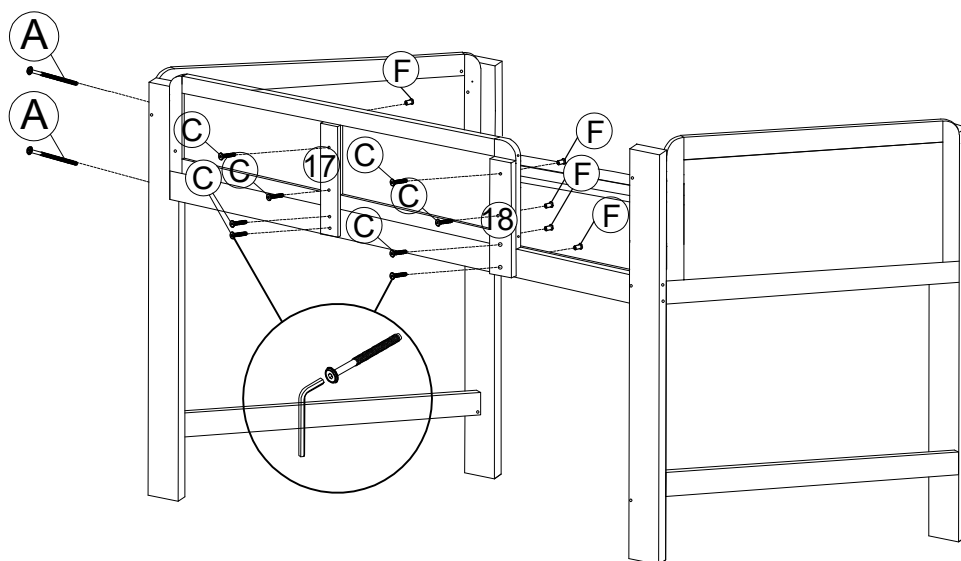
C		JCBC M6 x 30 MM JCBC M6 x 30 MM JCBC M6 x 30 MM	8
F		JCN NUT ECOUT JCN JCN MUTTER	8
A		JCBC M6 x 100 MM JCBC M6 x 100 MM JCBC M6 x 100 MM	2



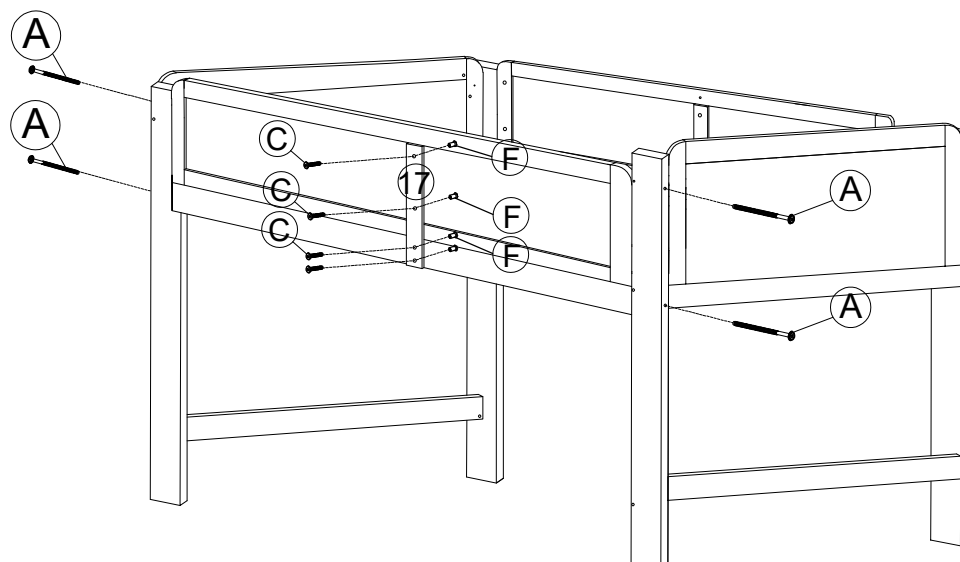

STEP 6 BACK

A		JCBC M6 x 100 MM JCBC M6 x 100 MM JCBC M6 x 100 MM	4
C		JCBC M6 x 30 MM JCBC M6 x 30 MM JCBC M6 x 30 MM	4
F		JCN NUT ECOUT JCN JCN MUTTER	4





ASSEMBLY INSTRUCTION/INSTRUCTIONS DE MONTAGE/ ASSEMBLERGEFEHL

STEP 7 DRAWER A

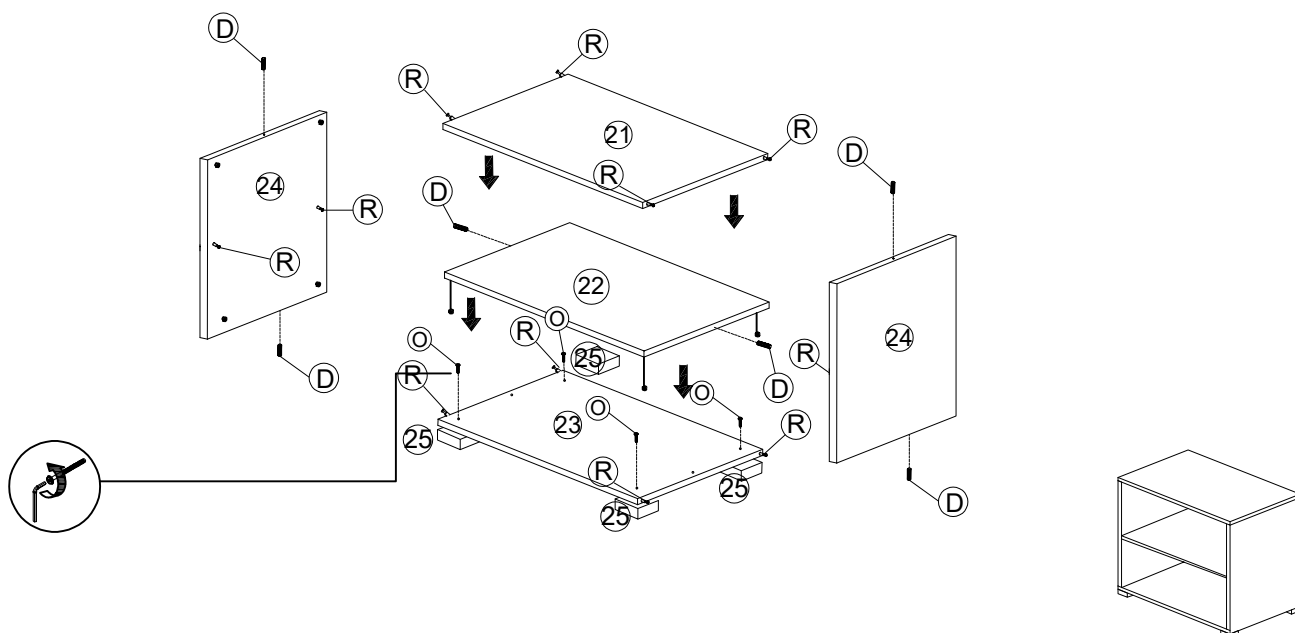
R		MINI FIX MM8.5 x 15MM MINI FIX MM8.5 x 15MM MINI FIX MM8.5 x 15MM	12
D		DOWEL M8 x 30 MM CHEVILLE EN BOIS M8 x 30 MM HOLZ-DÜBEL M8 x 30 MM	6
O		JCBC M6 x 20 MM JCBC M6 x 20 MM JCBC M6 x 20 MM	4



STEP 8 DRAWER B

R		MINI FIX MM8.5 x 15MM MINI FIX MM8.5 x 15MM MINI FIX MM8.5 x 15MM	12
D		DOWEL M8 x 30 MM CHEVILLE EN BOIS M8 x 30 MM HOLZ-DÜBEL M8 x 30 MM	6
O		JCBC M6 x 20 MM JCBC M6 x 20 MM JCBC M6 x 20 MM	4

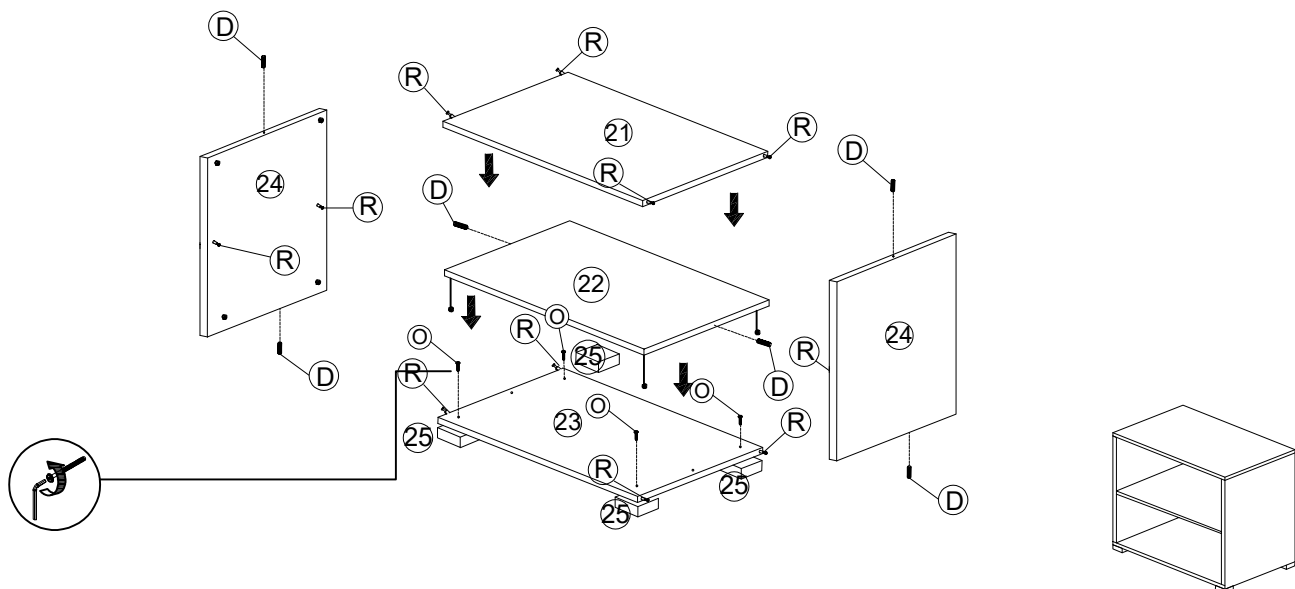

ASSEMBLY INSTRUCTION/INSTRUCTIONS DE MONTAGE/ ASSEMBLERGEFEHL

STEP 9 BACK DRAWER

L		NAIL PIN 15MM GOUPILLE À CLOU 15MM NAGELNADEL 15MM	36
---	---	--	----

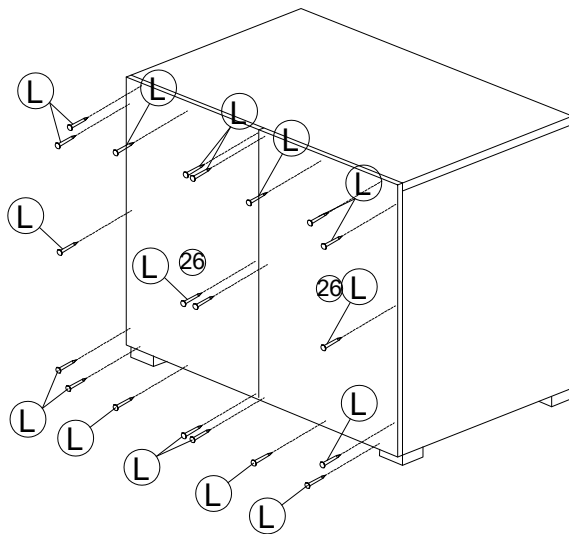

DRAWER A

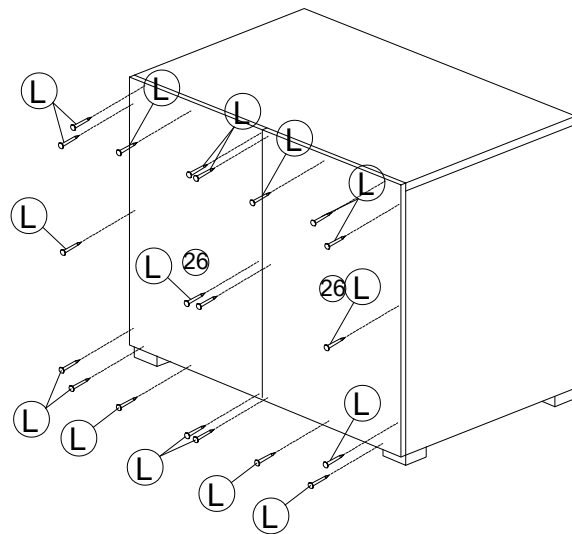

DRAWER B

STEP 10

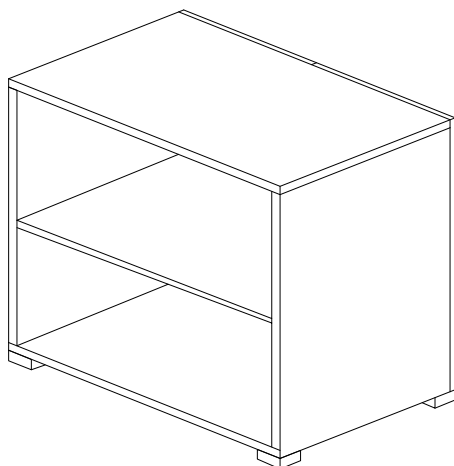



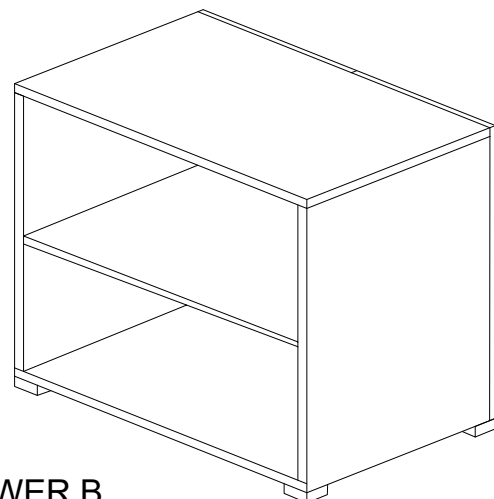

DRAWER A



DRAWER B

ASSEMBLY INSTRUCTION/INSTRUCTIONS DE MONTAGE/ ASSEMBLERGEFEHL

STEP 11

G		MINI FIX M12 x 16 MM GOUPILLE À CLOU 15MM NAGELNADEL 15MM	4
D		DOWEL M8 x 30 MM CHEVILLE EN BOIS M8 x 30 MM HOLZ-DÜBEL M8 x 30 MM	4
I		HINGES CHARNIÈRES SCHARNIERE	2
K		PANHEAD SCREW M3.5 x 16 MM VIS PANHEAD M3.5 x 16 MM LINSENKOPF-SCHRAUBE M3.5 x 16 MM	4

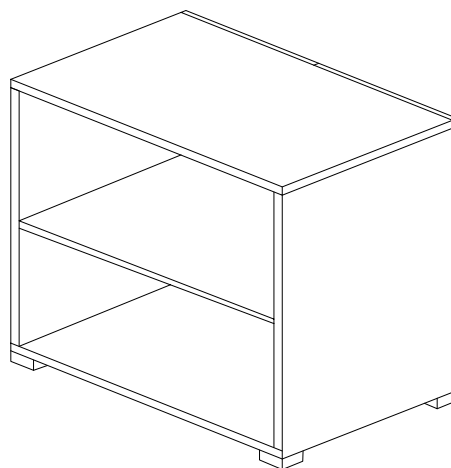
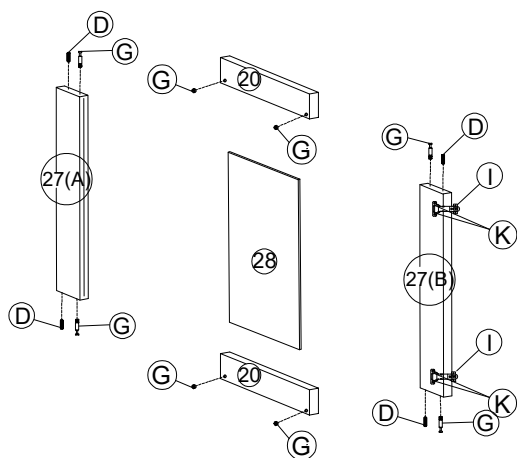

DRAWER A

STEP 12

I		HINGES CHARNIÈRES SCHARNIERE	4
K		PANHEAD SCREW M3.5 x 16 MM VIS PANHEAD M3.5 x 16 MM LINSENKOPF-SCHRAUBE M3.5 x 16 MM	8

HARDWARE NOT INCLUDE

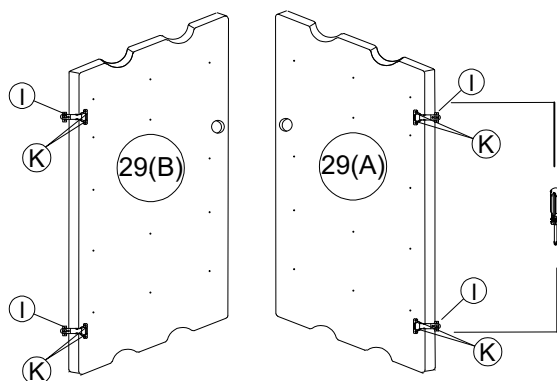
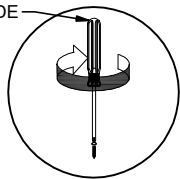

DRAWER B

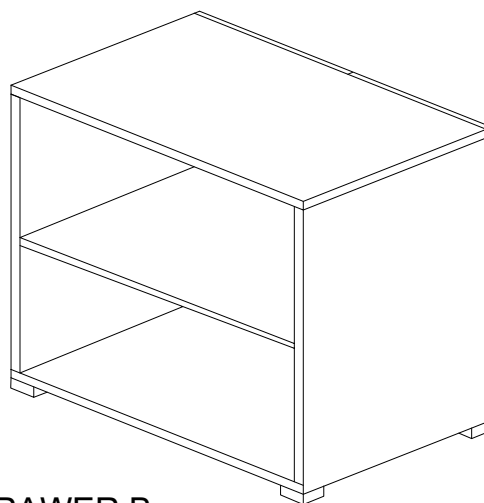

DRAWER B

ASSEMBLY INSTRUCTION/INSTRUCTIONS DE MONTAGE/ ASSEMBLERGEFEHL

STEP 13

K		PANHEAD SCREW M3.5 x 16 MM VIS PANHEAD M3.5 x 16 MM LINSENKOPF-SCHRAUBE M3.5 x 16 MM	12
---	---	--	----

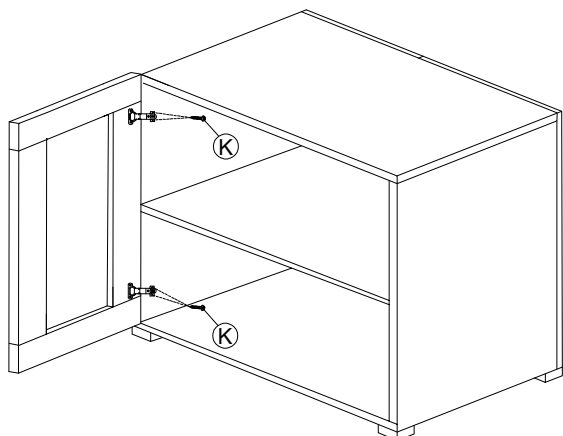

DRAWER A

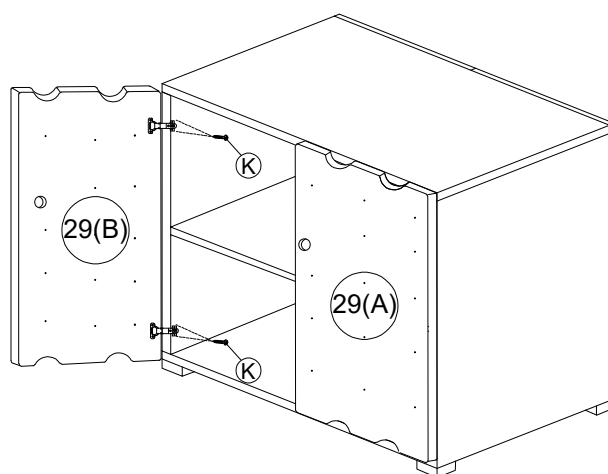

DRAWER B

STEP 14



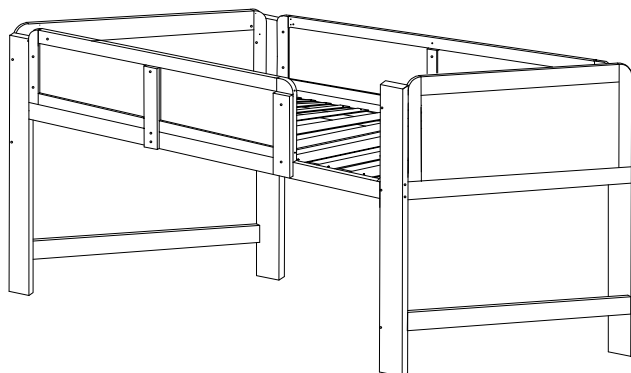
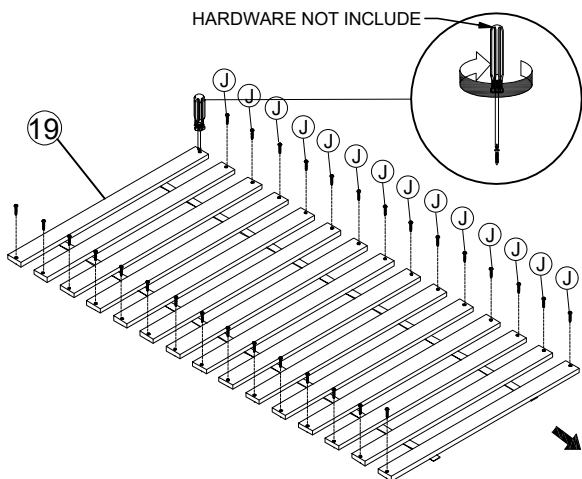

J		PANHEAD SCREW M4 x 25 MM VIS PANHEAD M4 x 25 MM LINSENKOPF-SCHRAUBE M4 x 25 MM	30
---	---	--	----

HARDWARE NOT INCLUDE



ASSEMBLY INSTRUCTION/INSTRUCTIONS DE MONTAGE/ ASSEMBLERGEFEHL

STEP 15

B		JCBC M6 x 60 MM JCBC M6 x 60 MM JCBC M6 x 60 MM	4
E		DOWEL M10 x 40 MM CHEVILLE EN BOIS M10 x 40 MM HOLZ-DÜBEL M10 x 40 MM	4
M		LADDER HOOK CROCHET D'ÉCHELLE LEITER-HAKEN	2
P		CSK SCREW M3.5 x 60 MM VIS CSK M3.5 x 60 MM CSK SCHRAUBE M3.5 x 60 MM	4

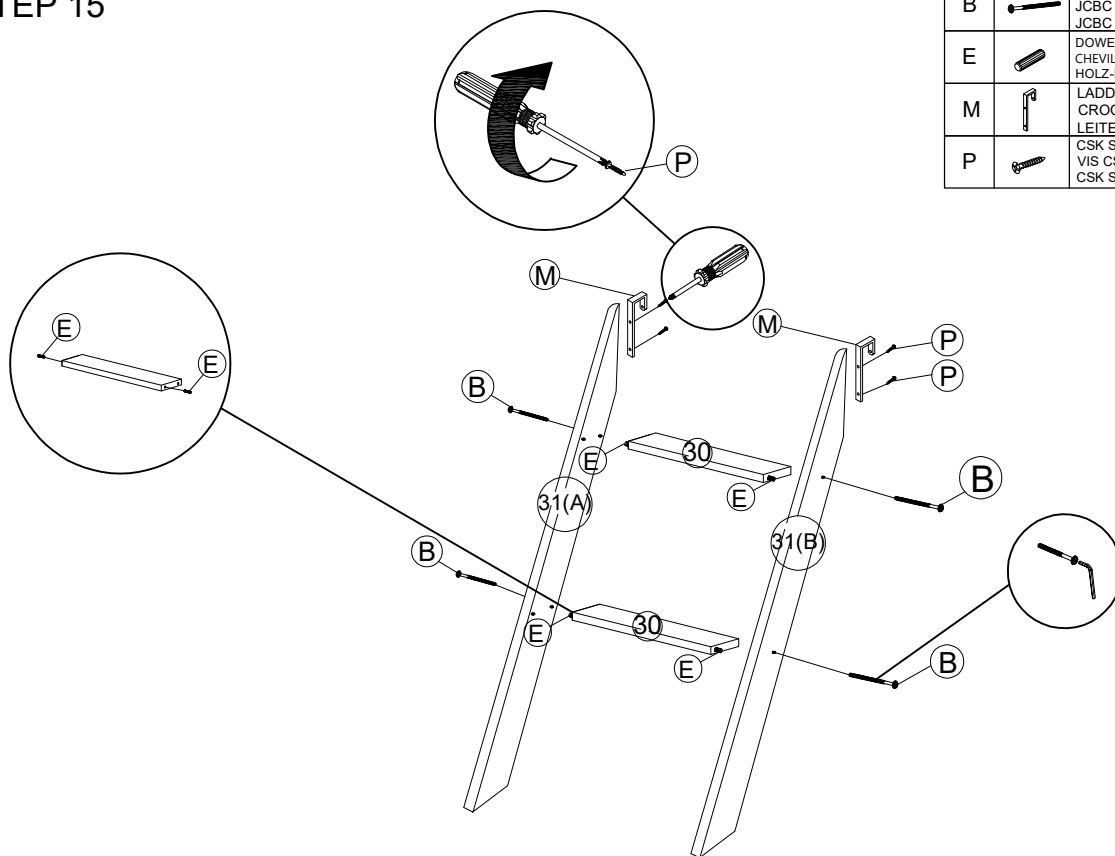

STEP 16

P		CSK SCREW M3.5 x 60 MM VIS CSK M3.5 x 60 MM CSK SCHRAUBE M3.5 x 60 MM	2
---	---	---	---

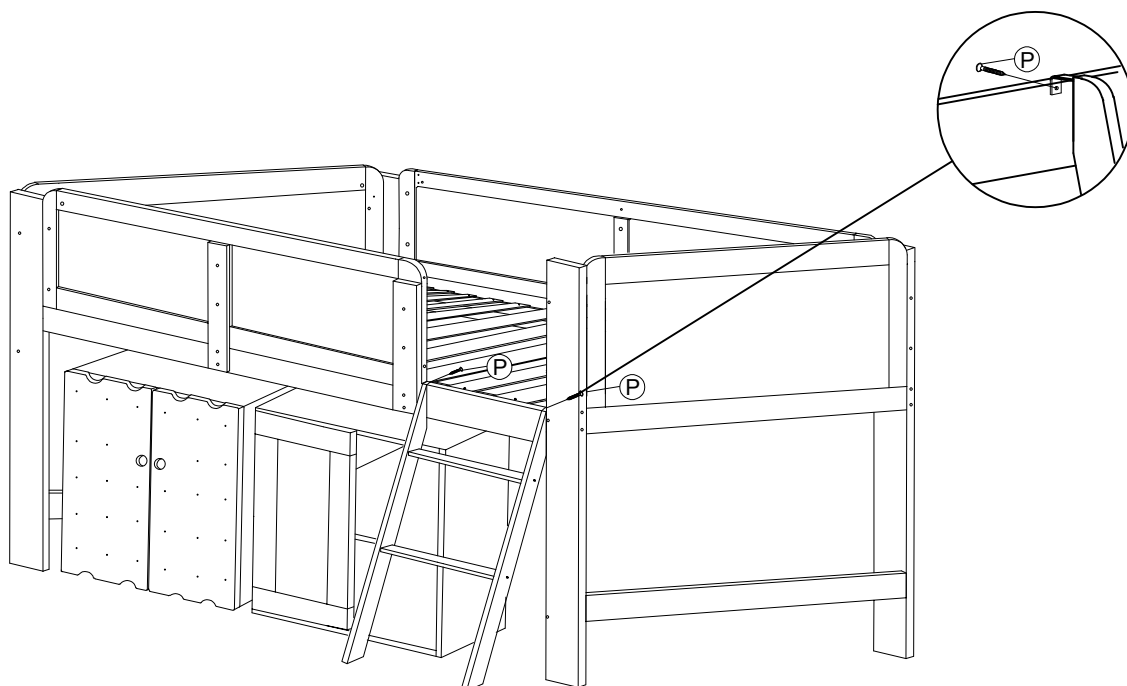

Wichtiger Hinweis:

Bestätigen Sie bitte alle Komponenten und Schrauben vor der Montage. Bitte wenden Sie sich an uns, falls einige Teile oder Schrauben im Paket fehlt sind.



ATTENTION !
NE PAS LAISSER LES
ENFANTS SE
SUSPENDRE
AUX BARRES!

