

# N635P418251/N635P418252/N635P418253

Product manual  
 Gebrauchsanweisung  
 Manuel du produit  
 Manual del producto  
 Manuale del prodotto

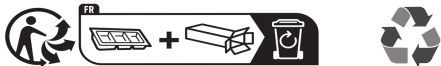

EN:Our product will be delivered to you in 3 packages. The delivery times of these 3 packages may differ, please be patient and thank you for your understanding  
 FR:Notre produit vous sera livré en 3 colis. Les délais de livraison de ces 3 colis peuvent différer, soyez patient et merci de votre compréhension.  
 DE:Unser Produkt wird Ihnen in 3 Paketen geliefert. Die Lieferzeiten dieser 3 Pakete können abweichen, bitte haben Sie etwas Geduld und vielen Dank für Ihr Verständnis  
 IT:I nostri prodotti vengono trasportati in due pacchetti. I tempi di consegna dei due pacchetti sono diversi: abbiate pazienza e vi ringrazio per la vostra comprensione.  
 ES:Nuestro producto se entrega en dos paquetes. El tiempo de entrega de estos dos paquetes es diferente. Por favor,



Importeur	Decobus Handel GmbH
Adresse	Innungsstraße 9, 21244 Buchholz, Deutschland
URL	<a href="https://www.decobusgroup.de">https://www.decobusgroup.de</a>
Hersteller	Shouguang Jiahao Import And Export Co. ,Ltd
Adresse	Room 501 Of Cultural And Creative Building, Weifang University Of Science And Technology, Shouguang City
Email/URL	SDSGMLG@163.COM
Partennummer	C035HHJ20251118TG
Hergestellt in	CHINA
EC REP	Decobus Handel GmbH Innungsstraße 9, 21244 Buchholz, Deutschland <a href="https://www.decobusgroup.de">https://www.decobusgroup.de</a>

 <b>2PERS</b>	 <b>45 MIN</b>	<b>Tool Required Not Provided</b> 
------------------	-------------------	---------------------------------------

Made in China



[DE]

**Warnung:** Lesen Sie diese Anleitung vor dem Zusammenbau bitte vollständig durch. Überprüfen Sie, ob Sie alle auf den Seiten aufgeführten Komponenten und Werkzeuge haben. Bewahren Sie die Anleitung zum späteren Nachschlagen auf. Teile des Zusammenbaus lassen sich mit 2 Personen leichter durchführen. Suchen Sie bei Bedarf professionelle Hilfe.

**Warnung:** Legen Sie alle Teile auf eine ebene Fläche. Legen Sie eine weiche Decke oder Ähnliches darunter, um sie vor Kratzern oder Flecken zu schützen. Vermeiden Sie es, Komponenten über den Boden zu ziehen oder zu schieben.

**Warnung:** Überprüfen Sie regelmäßig alle Beschläge und Befestigungen, um sicherzustellen, dass sie sicher sind und um Unfälle zu vermeiden. Wenn Teile fehlen, kaputt, beschädigt oder abgenutzt sind, verwenden Sie das Produkt nicht weiter, bis es mit vom Hersteller autorisierten Teilen repariert wurde.

**Warnung:** Lassen Sie Kinder nicht auf die Möbel klettern, da dies zum Umkippen und zu schweren Verletzungen führen kann. Bauen Sie die Möbel außerhalb der Reichweite von Kindern zusammen.

**Warnung:** Stellen Sie die Möbel nicht in die Nähe von Feuerquellen oder heißen Gegenständen, um Brandgefahr zu vermeiden.

**Warnung:** Reinigen Sie die Möbel mit einem feuchten Tuch oder Alkohol. Verwenden Sie keine Reinigungsmittel mit ätzenden Chemikalien.

**Warnung:** Dieses Produkt ist mit einer Kippschutzvorrichtung ausgestattet. Bitte installieren Sie diese Vorrichtung unbedingt, um unnötige Verletzungen durch Umkippen zu vermeiden.

[EN]

**Warning:** Please read these instructions fully before starting assembly. Check you have all the components and tools listed on pages. Keep the instructions for later reference. Parts of the assembly will be easier with 2 people. Seek professional assistance if necessary.

**Warning:** Please place all parts on a flat surface. Place a soft blanket or similar underneath to protect against scratches or stains. Avoid dragging or sliding components across the floor.

**Warning:** Regularly check all fittings and fastenings to ensure they are secure and to prevent accidents. If any parts are missing, broken, damaged, or worn, discontinue use of the product until repairs have been made using factory authorized parts.

**Warning:** Do not allow children to climb on the furniture as this may result in tipping and serious personal injury. Assemble the furniture away from the reach of children.

**Warning:** Do not place furniture close to fire sources or high-temperature objects to avoid the risk of fire. Do not place furniture in damp environments to prevent material damage.

**Warning:** Clean furniture with a damp cloth or alcohol, avoid using cleaning agents containing corrosive chemicals.

**Warning:** This product is equipped with an anti-tilt device. Please be sure to install this device to prevent unnecessary injuries caused by tipping.

[FR]

**Avertissement :** Veuillez lire attentivement ces instructions avant de commencer l'assemblage. Vérifiez que vous disposez de tous les composants et outils répertoriés sur les pages. Conservez les instructions pour référence ultérieure. Certaines parties de l'assemblage seront plus faciles à 2 personnes. Demandez l'aide d'un professionnel si nécessaire.

**Avertissement :** Veuillez placer toutes les pièces sur une surface plane. Placez une couverture douce ou similaire en dessous pour les protéger des rayures ou des taches. Évitez de faire glisser les composants sur le sol.

**Avertissement :** Vérifiez régulièrement tous les raccords et fixations pour vous assurer qu'ils sont bien fixés et

pour éviter les accidents. Si des pièces manquent, sont cassées, endommagées ou usées, cessez d'utiliser le produit jusqu'à ce que des réparations aient été effectuées à l'aide de pièces autorisées par l'usine.

**Avertissement** : Ne laissez pas les enfants grimper sur les meubles car cela pourrait entraîner un basculement et des blessures graves. Assemblez les meubles hors de portée des enfants.

**Avertissement** : Ne placez pas les meubles à proximité de sources de feu ou d'objets à haute température pour éviter tout risque d'incendie.

**Avertissement** : Nettoyez les meubles avec un chiffon humide ou de l'alcool, évitez d'utiliser des produits de nettoyage contenant des produits chimiques corrosifs.

**Avertissement** : Ce produit est équipé d'un dispositif anti-basculement. Assurez-vous d'installer ce dispositif pour éviter les blessures inutiles causées par un basculement.

[IT]

**Attenzione**: leggere attentamente queste istruzioni prima di iniziare il montaggio. Verificare di avere tutti i componenti e gli strumenti elencati nelle pagine. Conservare le istruzioni per riferimento futuro. Alcune parti del montaggio saranno più facili con 2 persone. Se necessario, chiedere assistenza professionale.

**Attenzione**: posizionare tutte le parti su una superficie piana. Posizionare una coperta morbida o simile sotto per proteggere da graffi o macchie. Evitare di trascinare o far scivolare i componenti sul pavimento.

**Attenzione**: controllare regolarmente tutti i raccordi e i dispositivi di fissaggio per assicurarsi che siano sicuri e per prevenire incidenti. Se alcune parti sono mancanti, rotte, danneggiate o usurate, interrompere l'uso del prodotto fino a quando non siano state eseguite le riparazioni utilizzando parti autorizzate dalla fabbrica.

**Attenzione**: non consentire ai bambini di arrampicarsi sui mobili poiché ciò potrebbe causare ribaltamenti e gravi lesioni personali. Montare i mobili lontano dalla portata dei bambini.

**Attenzione**: non posizionare i mobili vicino a fonti di fuoco o oggetti ad alta temperatura per evitare il rischio di incendio

**Attenzione**: pulire i mobili con un panno umido o alcol, evitare di utilizzare detergenti contenenti sostanze chimiche corrosive.

**Attenzione**: questo prodotto è dotato di un dispositivo antiribaltamento. Assicurarsi di installare questo dispositivo per prevenire lesioni inutili causate dal ribaltamento.

[ES]

**Advertencia**: Lea estas instrucciones completamente antes de comenzar el montaje. Compruebe que tiene todos los componentes y herramientas que se enumeran en las páginas. Conserve las instrucciones para consultarlas más adelante. El montaje de algunas partes será más sencillo con 2 personas. Busque ayuda profesional si es necesario.

**Advertencia**: Coloque todas las piezas sobre una superficie plana. Coloque una manta suave o algo similar debajo para protegerlas de rayones o manchas. Evite arrastrar o deslizar los componentes por el piso.

**Advertencia**: Verifique regularmente todos los accesorios y fijaciones para asegurarse de que estén seguros y evitar accidentes. Si falta alguna pieza, está rota, dañada o desgastada, deje de usar el producto hasta que se hayan realizado las reparaciones con piezas autorizadas de fábrica.

**Advertencia**: No permita que los niños se suban a los muebles, ya que esto puede provocar que se vuelquen y lesiones personales graves. Monte los muebles fuera del alcance de los niños.

**Advertencia**: No coloque los muebles cerca de fuentes de fuego u objetos de alta temperatura para evitar el riesgo de incendio.

**Advertencia**: Limpie los muebles con un paño húmedo o alcohol, evite usar agentes de limpieza que contengan químicos corrosivos.

**Advertencia**: Este producto está equipado con un dispositivo antivuelco. Asegúrese de instalar este dispositivo para evitar lesiones innecesarias causadas por vuelcos.

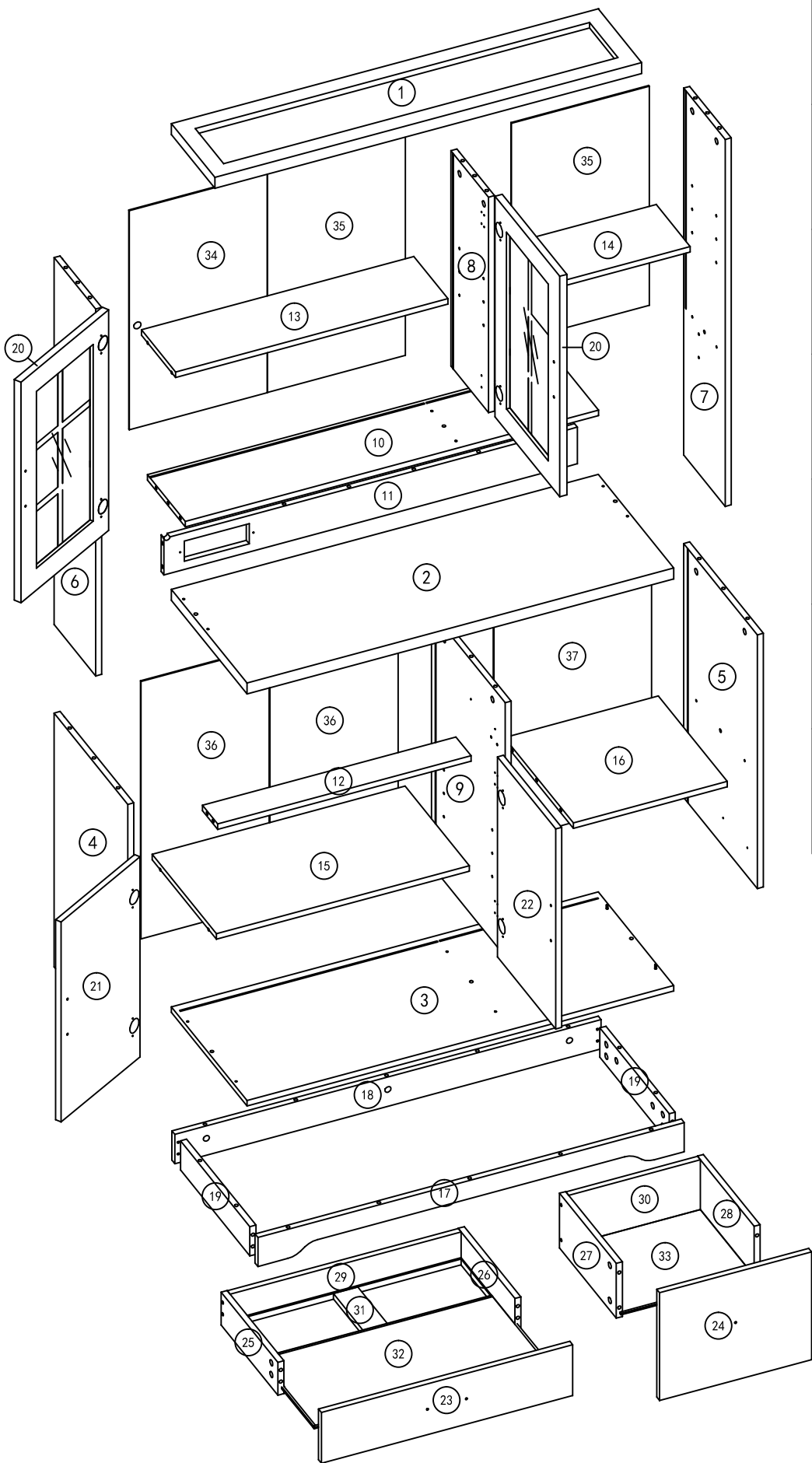

A	59PCS	B	59PCS Φ15*11
C	22PCS Φ8*40	D	12PCS M5*40
E	2SET DR DL CR CL 300	F	5PCS M4*18
G	1PCS M4*18	H	6PCS
J	2PCS	K	8PCS M4*35
L	66PCS M3.5*14	M	12PCS
N	8PCS	O	24PCS
P	1PCS	Q	1PCS
R	1PCS L=588mm	S	1PCS L=693mm
T	2PCS		



**EN\_QUICKFIT:** Tighten quickfit until shoulder is flush with panel. Do not overtighten or undertighten.

**FR\_RACCORD RAPIDE:** Faites serrer le raccord rapide jusqu'à ce que l'épaulement soit parfaitement encastré dans le panneau. Il ne faut ni trop serrer ni insuffisamment serrer.

**ES\_QUICKFIT:** Apriete quickfit hasta que el hombro se descargue con el panel. NO lo sobreapriete ni lo apriete poco.

**DE\_QUICKFIT:** Ziehen Sie den Quickfit fest, bis die Schulter mit der Platte bündig ist. Bitte nicht zu fest oder zu schwach anziehen.

**IT\_MONTAGGIO RAPIDO:** Stringere il montaggio rapido fino a quando la spalla è a filo con il pannello, non stringere troppo o troppo poco.

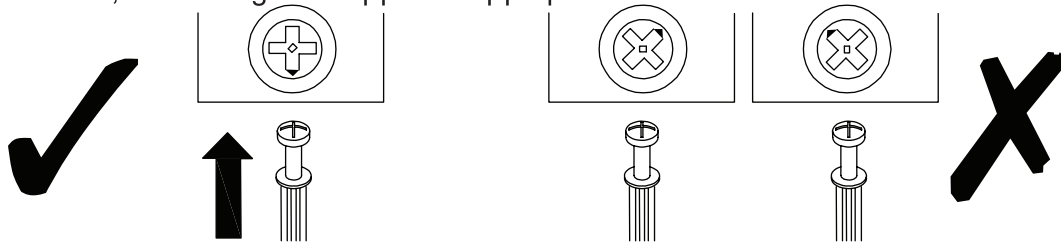

**EN\_CAM LOCK:** When fitting cam lock, ensure starting position is correct before you insert connecting quickfit.

**FR\_SERRURE BATTEUSE:** Avant d'insérer la serrure batteuse, veillez à la bonne orientation avant d'insérer le raccord rapide.

**ES\_CIERRE DE LA CÁMARA:** Cuando instale el cierre de la cámara, asegúrese de que la posición de inicio es correcta antes de que inserte el quickfit conector.

**DE\_CAM-LOCK:** Achten Sie bei der Montage des Cam-Locks auf die richtige Ausgangsposition, bevor Sie den Quickfit einsetzen.

**IT\_BLOCCAGGIO A CAMMA:** Quando si monta il bloccaggio a camma, assicurarsi che la posizione iniziale sia corretta prima di inserire il montaggio rapido di collegamento.



**EN\_Quickfit head** should be in the centre of the cam lock when the two panels are joined.

Cam lock should be inserted before quickfit.

**FR\_Lorsque** les deux panneaux sont assemblés, la tête du raccord rapide doit reposer au centre de la serrure batteuse. Il faut insérer la serrure batteuse avant le raccord rapide.

**ES\_El** cabezal del quickfit debe estar en el centro del cierre de la cámara cuando se unan los dos paneles.

Se debe insertar el cierre de la cámara antes que el quickfit.

**DE\_Der** Quickfit-Kopf sollte sich in der Mitte des Cam-Locks befinden, wenn die beiden Platten zusammengefügt sind. Der Cam-Lock sollte vor dem Quickfit eingesetzt werden.

**IT\_La** testa del montaggio rapido deve trovarsi al centro del bloccaggio a camma quando i due pannelli sono uniti.

Il Bloccaggio a Camma deve essere inserito prima del montaggio rapido.

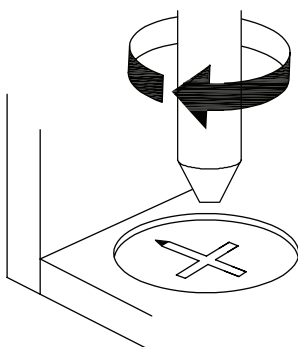

**EN\_Turn** cam lock clockwise to tighten.

**FR\_Faites** tourner la serrure batteuse dans le sens des aiguilles d'une montre pour la resserrer.

**ES\_Gire** el cierre de la cámara en sentido horario para apretarlo.

**DE\_Drehen** Sie den Cam-Lock im Uhrzeigersinn, um ihn festzuziehen.

**IT\_Ruotare** il bloccaggio a camma in senso orario per stringere.

**EN** It may be necessary to adjust the hinges so that the doors align. Use the instructions below as a guide.

**FR** Il est parfois nécessaire d'ajuster les charnières pour un meilleur alignement des portes. Servez-vous des instructions ci-dessous comme guide.

**ES** Puede que sea necesario ajustar los quicios de forma que se alineen las puertas. Use las instrucciones que aparecen debajo como guía.

**DE** Möglicherweise müssen Sie die Scharniere so einstellen, dass die Türen ausgerichtet sind. Verwenden Sie die nachstehenden Anweisungen als Leitfaden.

**IT** Potrebbe essere necessario regolare le cerniere in modo che le porte siano allineate. Per fare ciò attenersi alle istruzioni sottostanti.

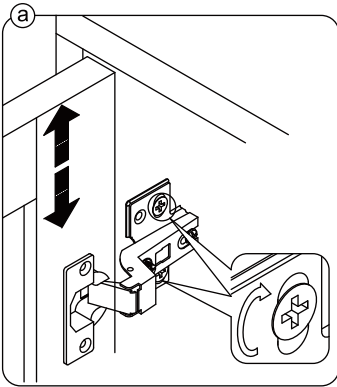

**EN** To adjust the door vertically loosen the screw as shown and move up and down as needed.

**FR** Si vous souhaitez régler la porte **verticalement**, desserrez la vis comme indiqué et déplacez la porte de haut en bas selon les besoins.

**ES** Para ajustar la puerta **verticalmente** afloje el tornillo tal y como se muestra y muévelo hacia arriba o hacia abajo según sea necesario.

**DE** Um die Tür **vertikal** auszurichten, lösen Sie die Schraube wie abgebildet und bewegen Sie sie nach Bedarf nach oben oder nach unten.

**IT** Per allineare la porta **verticalmente** allentare la vite come mostrato e spostarla in alto o in basso secondo necessità.

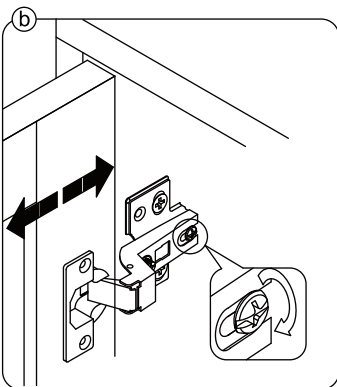

**EN** To adjust the gap from the door to the main frame turn the screw clockwise or anti-clockwise as needed.

**FR** Si vous souhaitez ajuster l'**écart** entre la porte et le cadre principal, tournez la vis dans le sens des aiguilles d'une montre ou dans le sens inverse, si nécessaire.

**ES** Para ajustar el **espacio** desde la puerta al marco principal, gire el tornillo en sentido horario o antihorario, según se necesite.

**DE** Um den **Abstand** von der Tür zum Hauptrahmen auszurichten, drehen Sie die Schraube je nach Bedarf im oder gegen den Uhrzeigersinn.

**IT** Per regolare lo **spazio** tra la porta e il telaio principale, avvitare o svitare la vite secondo necessità.

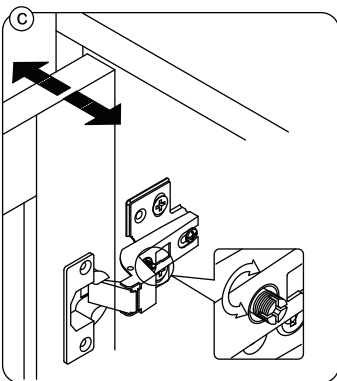

**EN** To adjust the door laterally adjust the screw as shown by turning clockwise or anti-clockwise.

**FR** Si vous souhaitez ajuster la porte **latéralement**, ajustez la vis comme indiqué en tournant dans le sens des aiguilles d'une montre ou dans le sens inverse des aiguilles d'une montre.

**ES** Para ajustar la puerta **lateralmente** ajuste el tornillo tal y como se muestra girándolo en sentido horario y antihorario.

**DE** Um die Tür **seitlich** auszurichten, stellen Sie bitte die Schraube wie abgebildet durch Drehen im oder gegen den Uhrzeigersinn ein.

**IT** Per allineare la porta **lateralmente** regolare la vite come mostrato, avvitarandola o svitarandola.

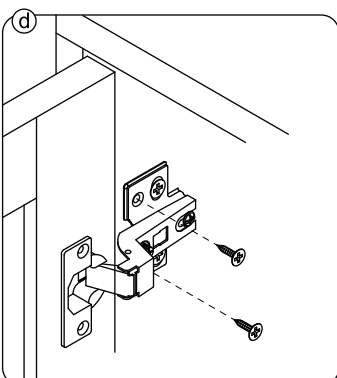



**EN** Please fix other screws

**FR** Merci de serrer les autres vis.

**ES** Fije los demás tornillos

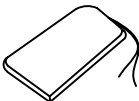

**DE** Befestigen Sie bitte die anderen Schrauben

**IT** Fissare le altre viti

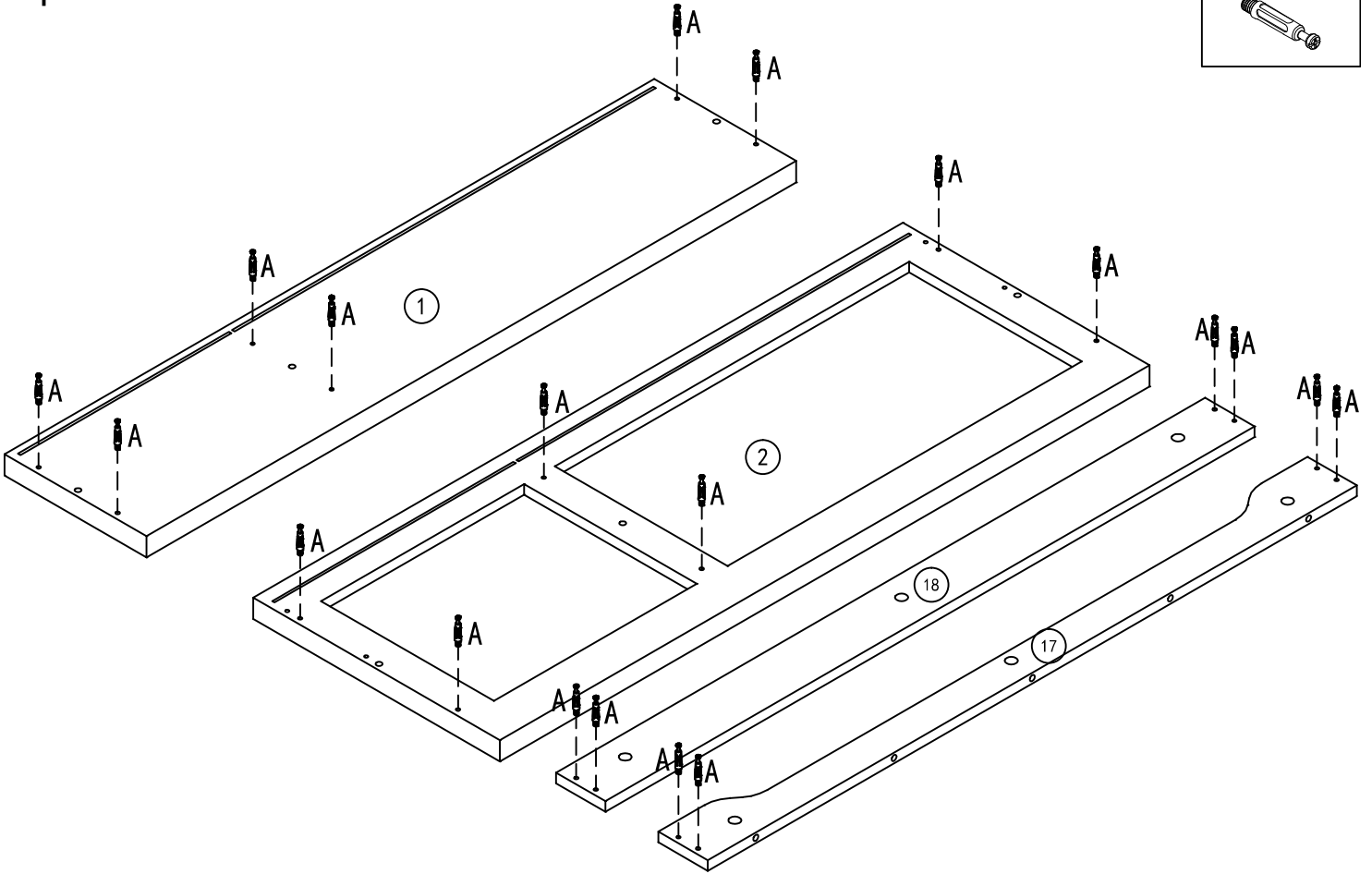

BOX 1-3	N635P418251	BOX 2-3	N635P418252	BOX 3-3	N635P418253
	① $1053 \times 230 \times 30=1PCS$		④ $695 \times 390 \times 15=1PCS$		⑧ $590 \times 199 \times 15=1PCS$
	② $1053 \times 400 \times 30=1PCS$		⑤ $695 \times 390 \times 15=1PCS$		⑫ $625 \times 80 \times 15=1PCS$
	③ $1053 \times 400 \times 15=1PCS$		⑨ $695 \times 390 \times 15=1PCS$		⑮ $624 \times 340 \times 15=1PCS$
	⑥ $1005 \times 220 \times 15=1PCS$		⑰ $367 \times 80 \times 15=2PCS$		⑰ $380 \times 365 \times 15=1PCS$
	⑦ $1005 \times 220 \times 15=1PCS$		⑳ $604 \times 342 \times 18=2PCS$		㉑ $548 \times 308 \times 15=1PCS$
	⑩ $1020 \times 200 \times 15=1PCS$		㉔ $600 \times 340 \times 3=1PCS$		㉒ $548 \times 308 \times 15=1PCS$
	⑪ $1020 \times 100 \times 15=1PCS$		㉕ $600 \times 340 \times 3=2PCS$		㉓ $620 \times 139 \times 15=1PCS$
	⑬ $672 \times 180 \times 15=1PCS$		㉖ $705 \times 316 \times 3=2PCS$		㉔ $375 \times 295 \times 15=1PCS$
	⑭ $331 \times 180 \times 15=1PCS$		㉗ $705 \times 389 \times 3=1PCS$		㉕ $300 \times 90 \times 15=1PCS$
	⑰ $1052 \times 80 \times 15=1PCS$				㉖ $300 \times 150 \times 15=1PCS$
	⑱ $1052 \times 80 \times 15=1PCS$		R 		㉗ $300 \times 90 \times 15=1PCS$
			S 		㉘ $300 \times 150 \times 15=1PCS$
					㉙ $570 \times 90 \times 15=1PCS$
					㉚ $325 \times 150 \times 15=1PCS$
					㉛ $284 \times 60 \times 15=1PCS$
					㉜ $580 \times 294 \times 3=1PCS$
					㉝ $335 \times 294 \times 3=1PCS$

1

A 20PCS



2

A 23PCS	F 1PCS	G 1PCS
		
	M4*18	M4*18

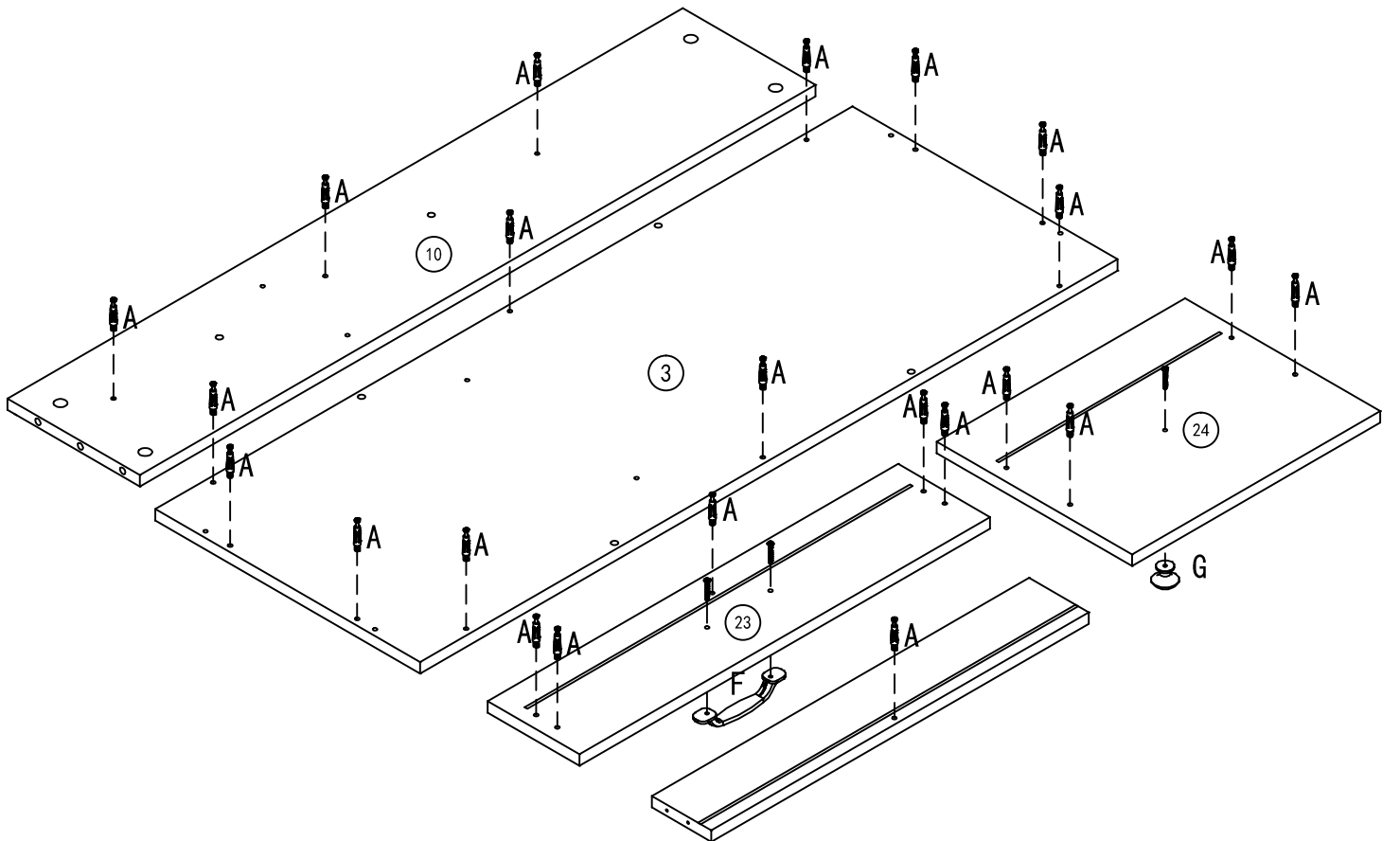

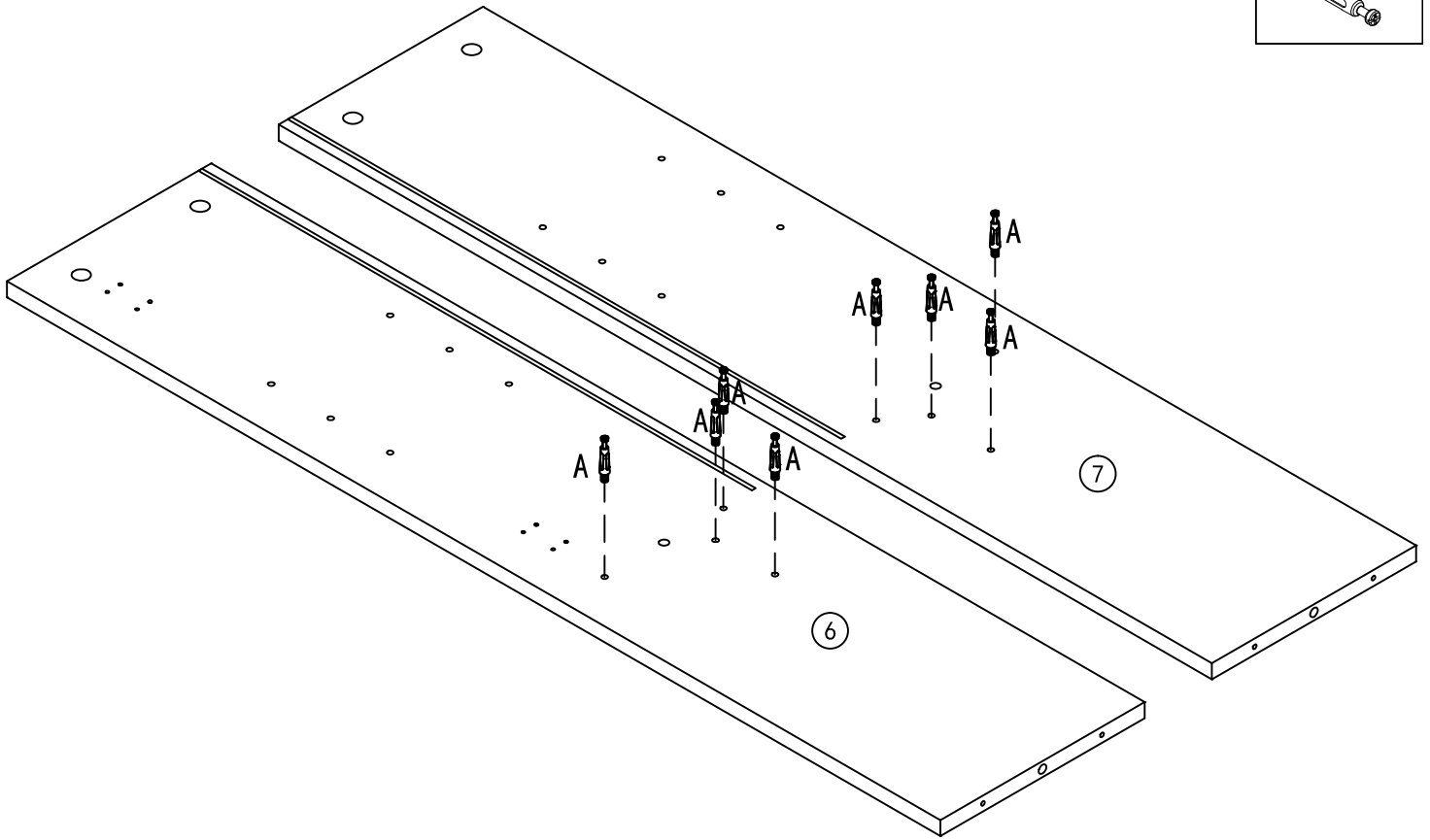
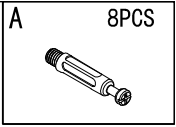

3

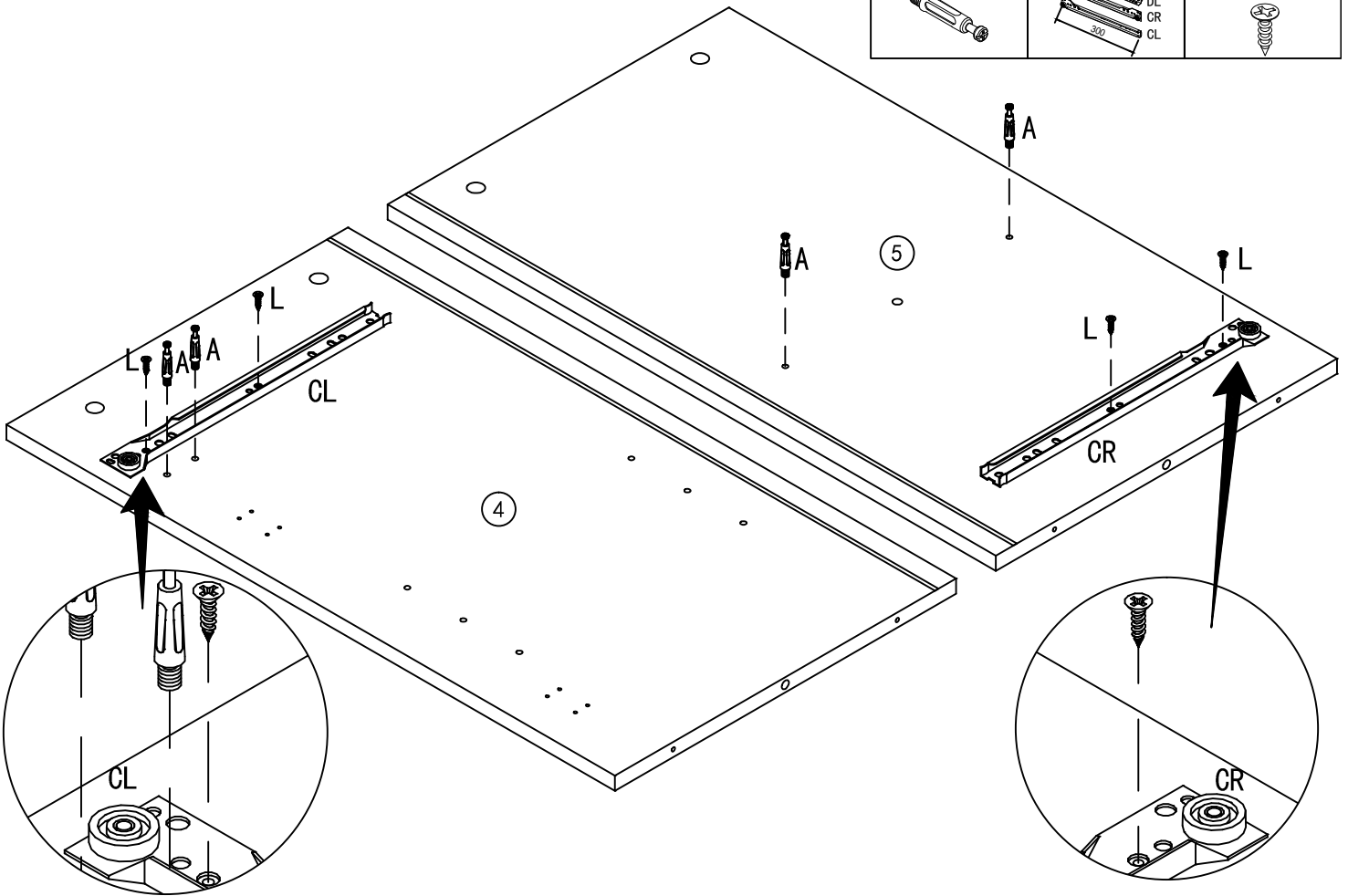
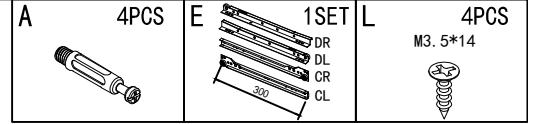

4



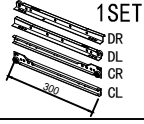

5

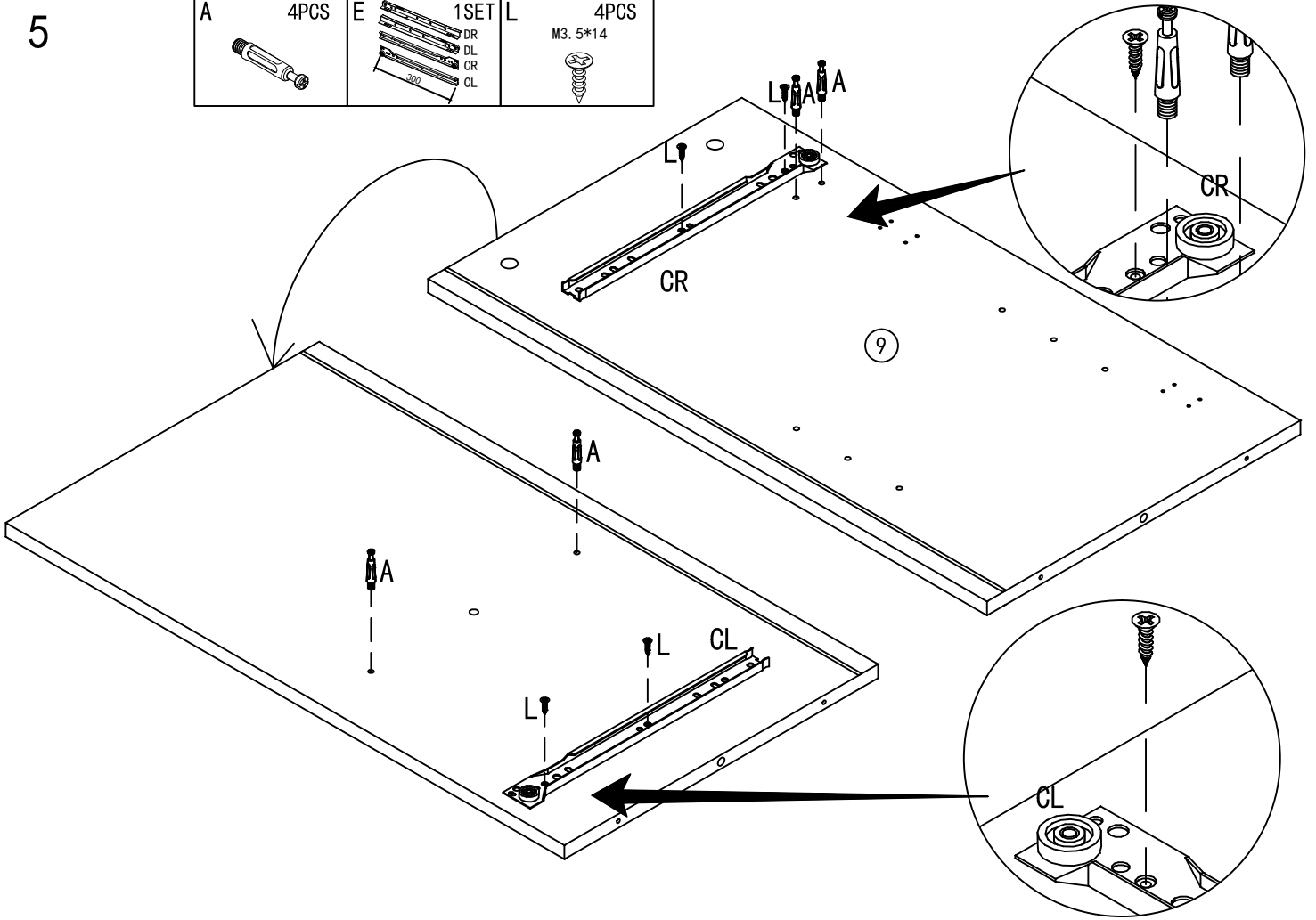
A	4PCS	E	1SET	L	4PCS
			DR DL CR CL		M3.5*14



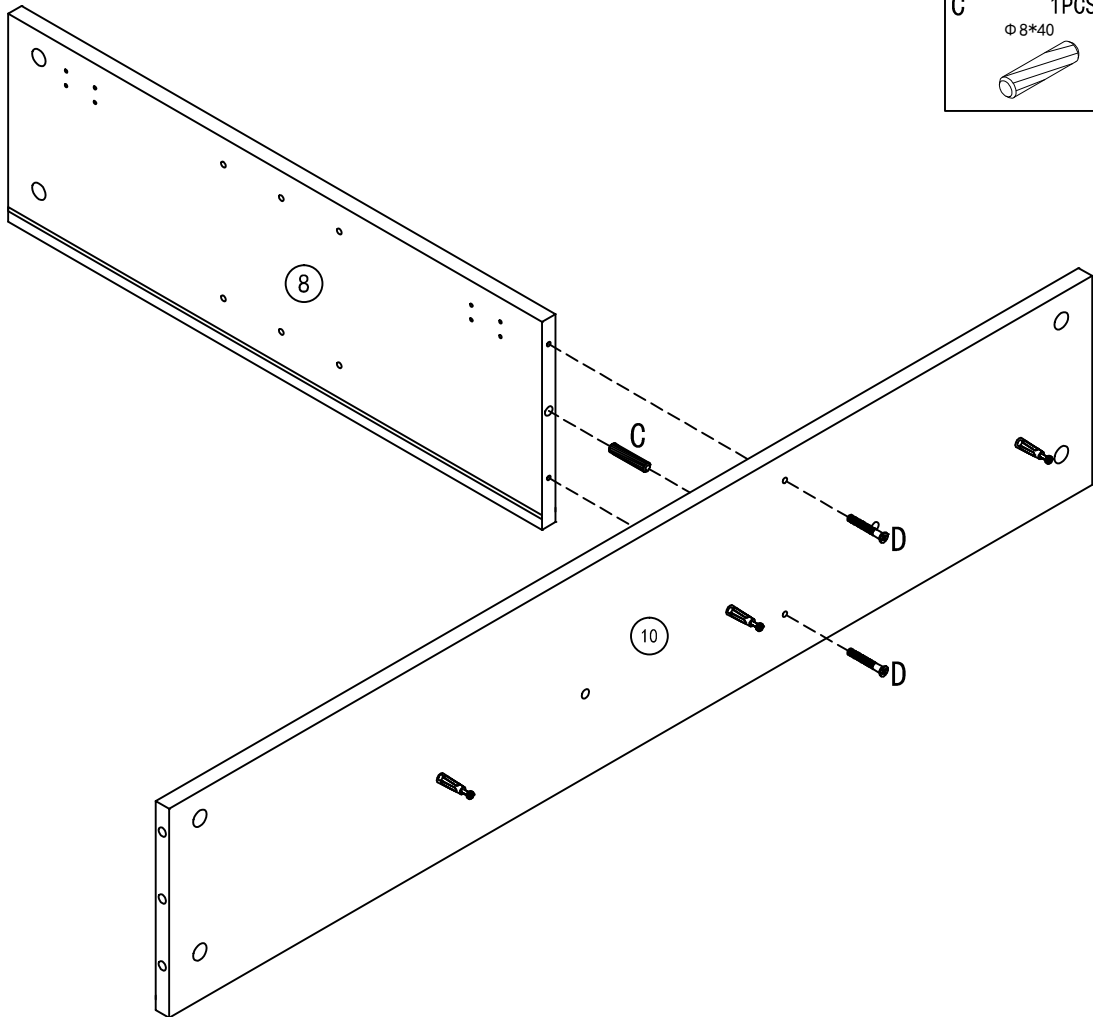

6

C	1PCS	D	2PCS
	$\Phi 8*40$		M5*40



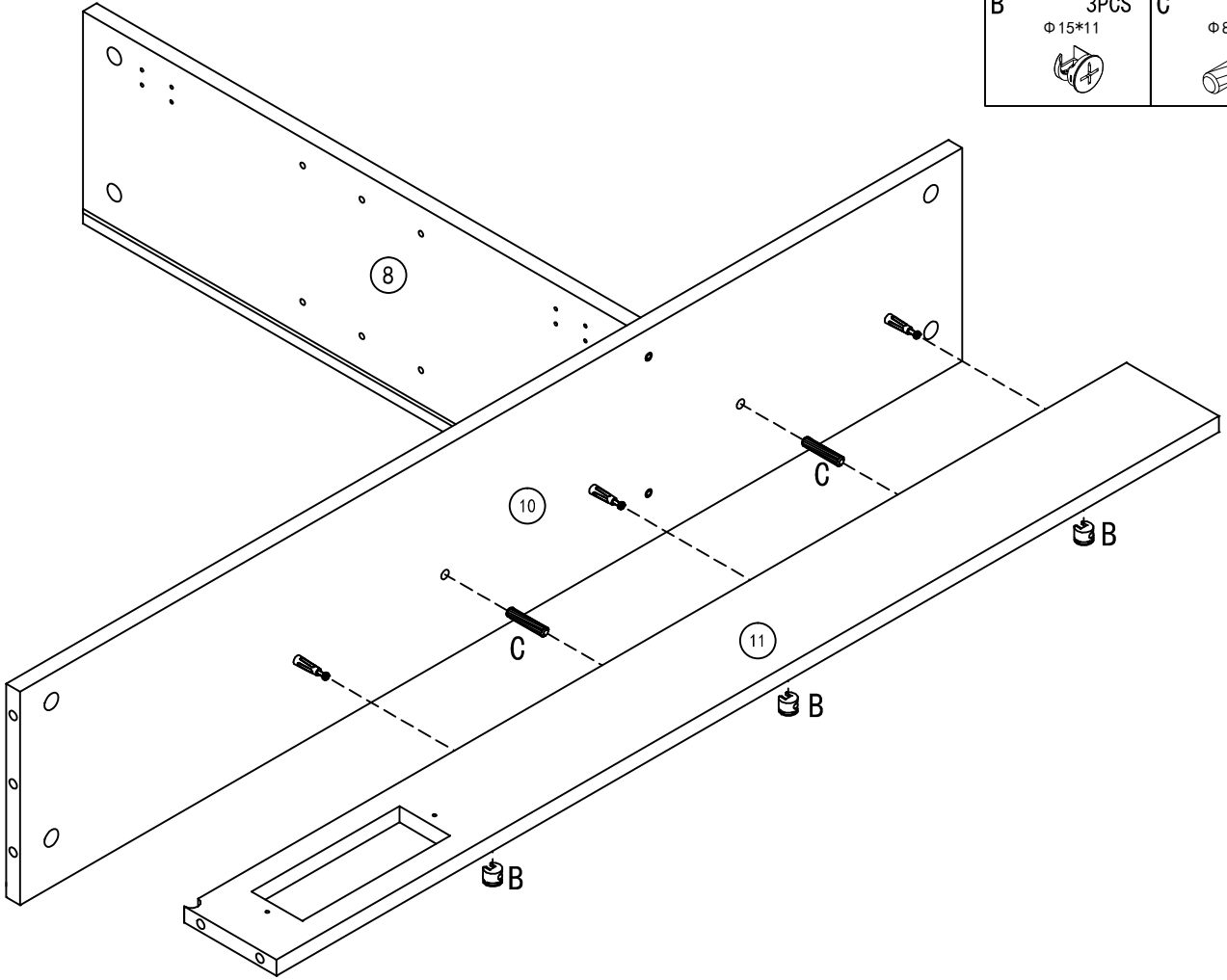

7

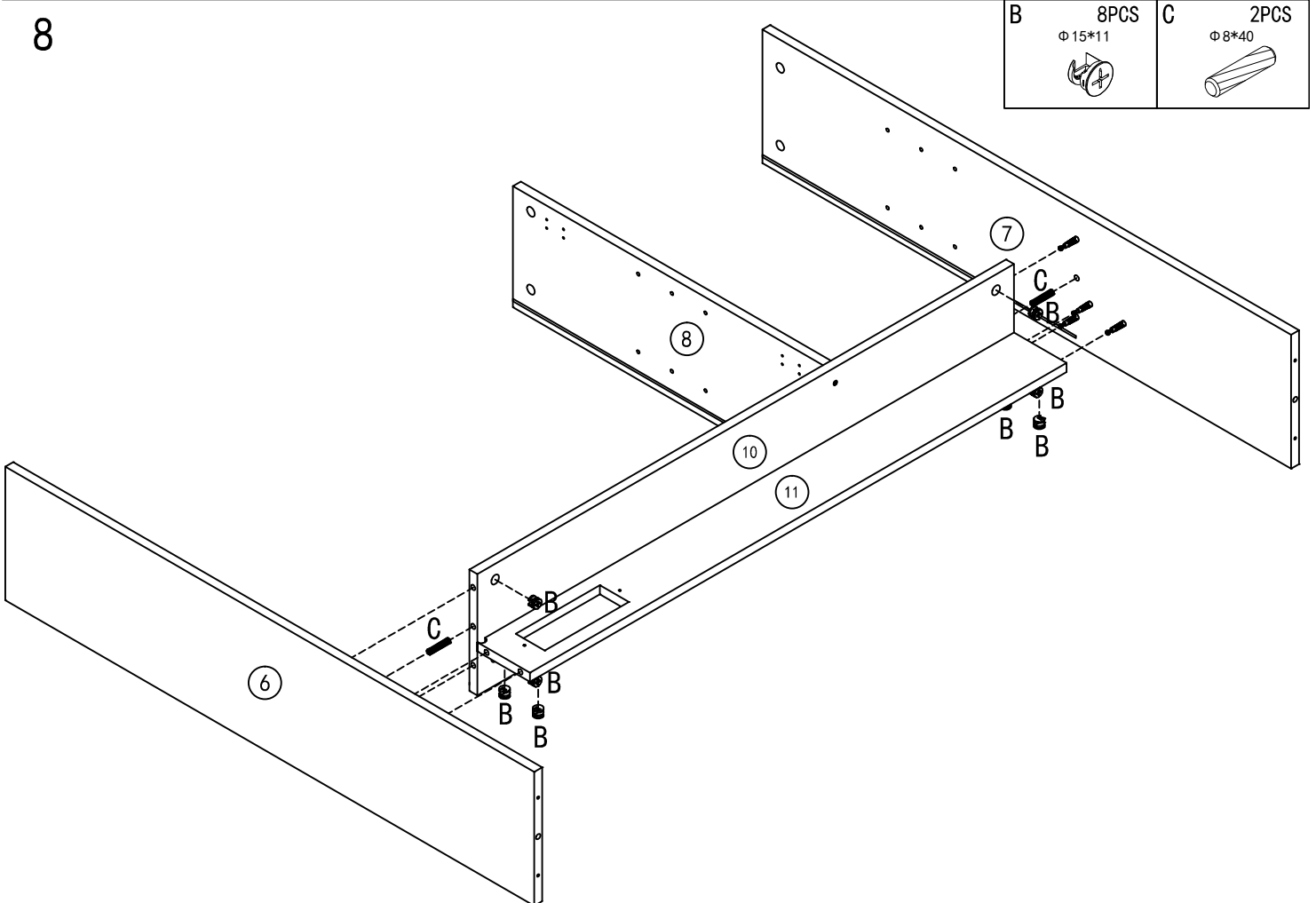

<b>B</b>	3PCS	<b>C</b>	2PCS
	Φ 15*11		Φ 8*40
			

8



<b>B</b>	8PCS	<b>C</b>	2PCS
	Φ 15*11		Φ 8*40
			

9

R 1PCS  
L=588mm

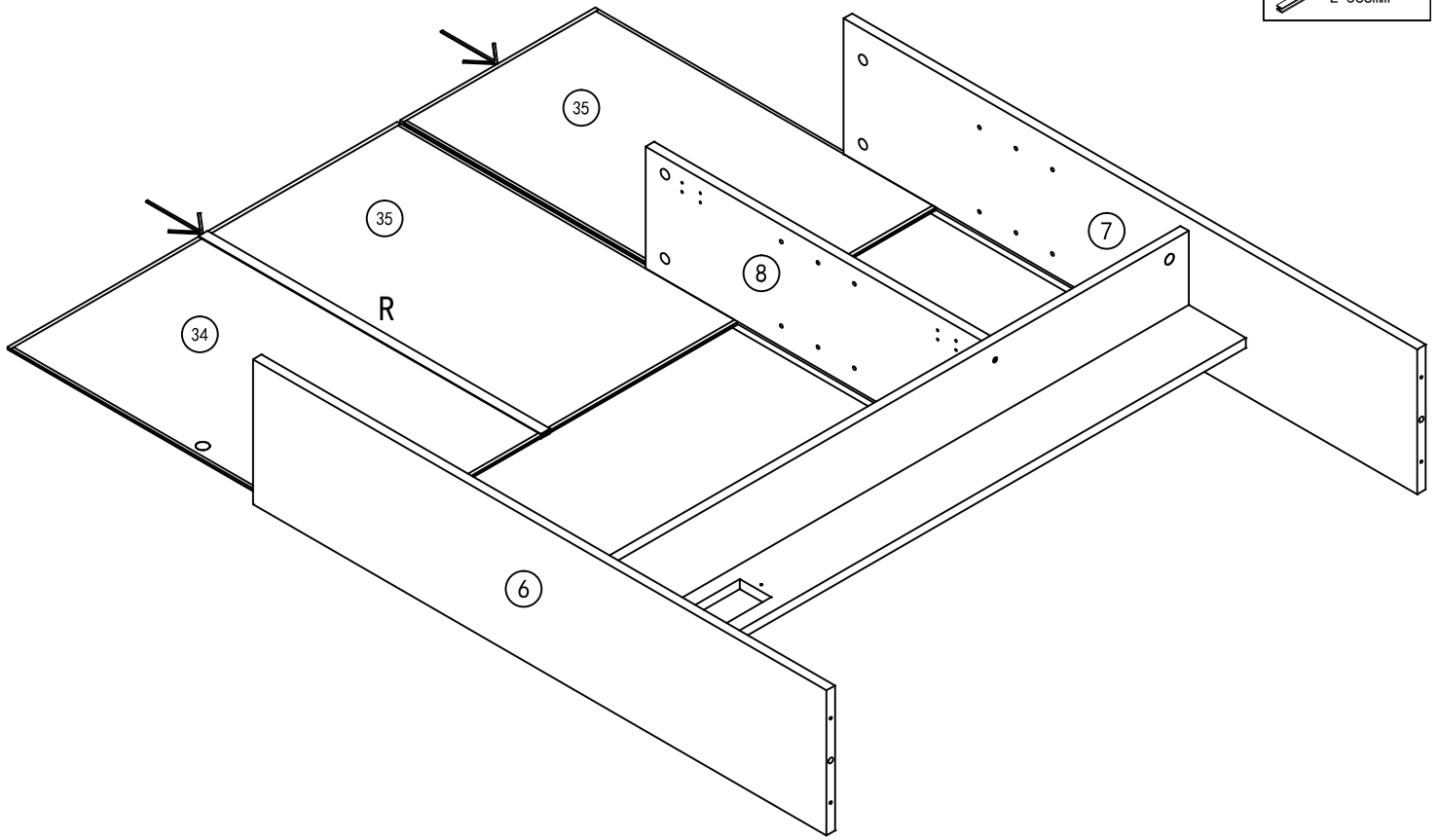

10

B 6PCS  $\Phi 15 \times 11$   
C 3PCS  $\Phi 8 \times 40$

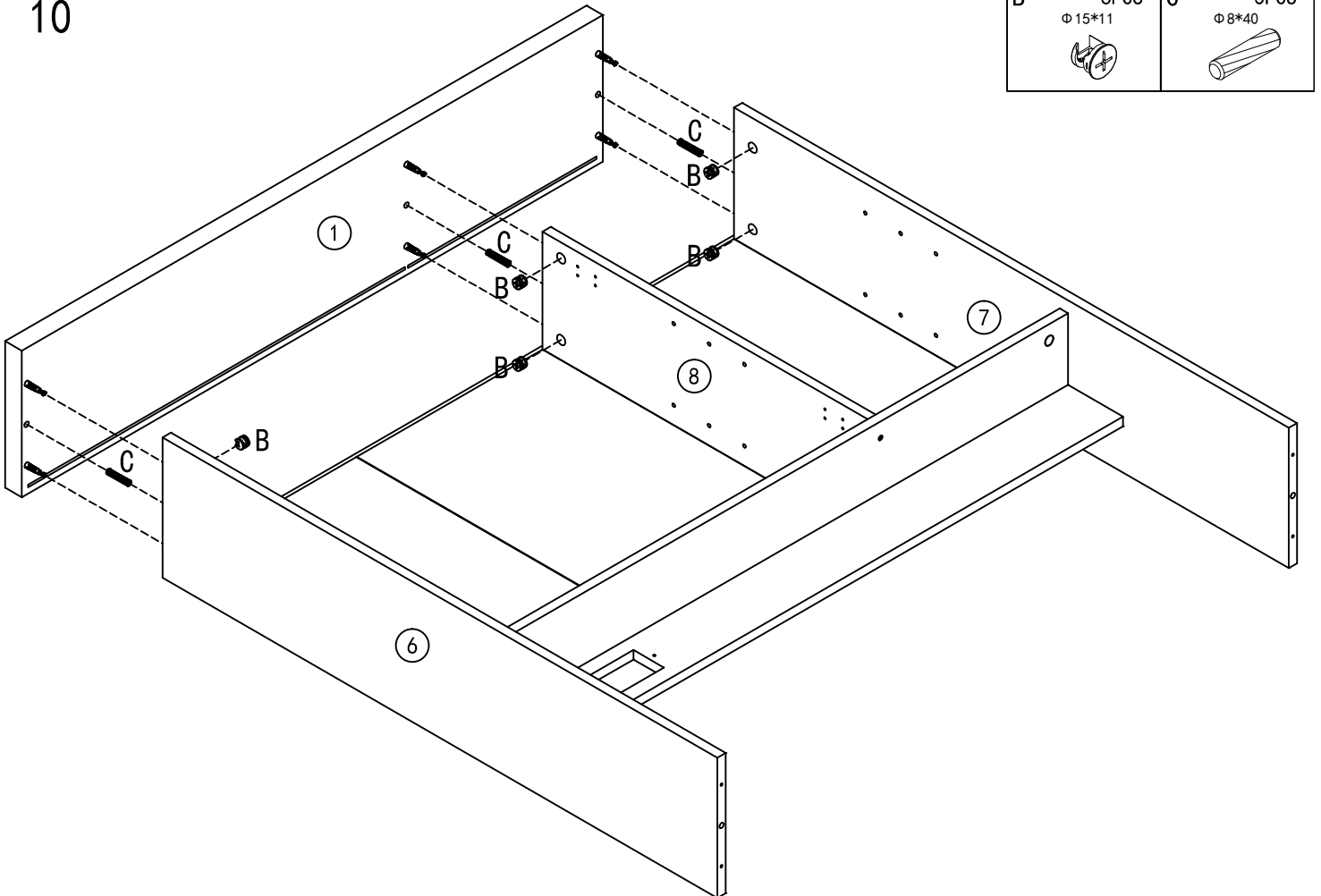

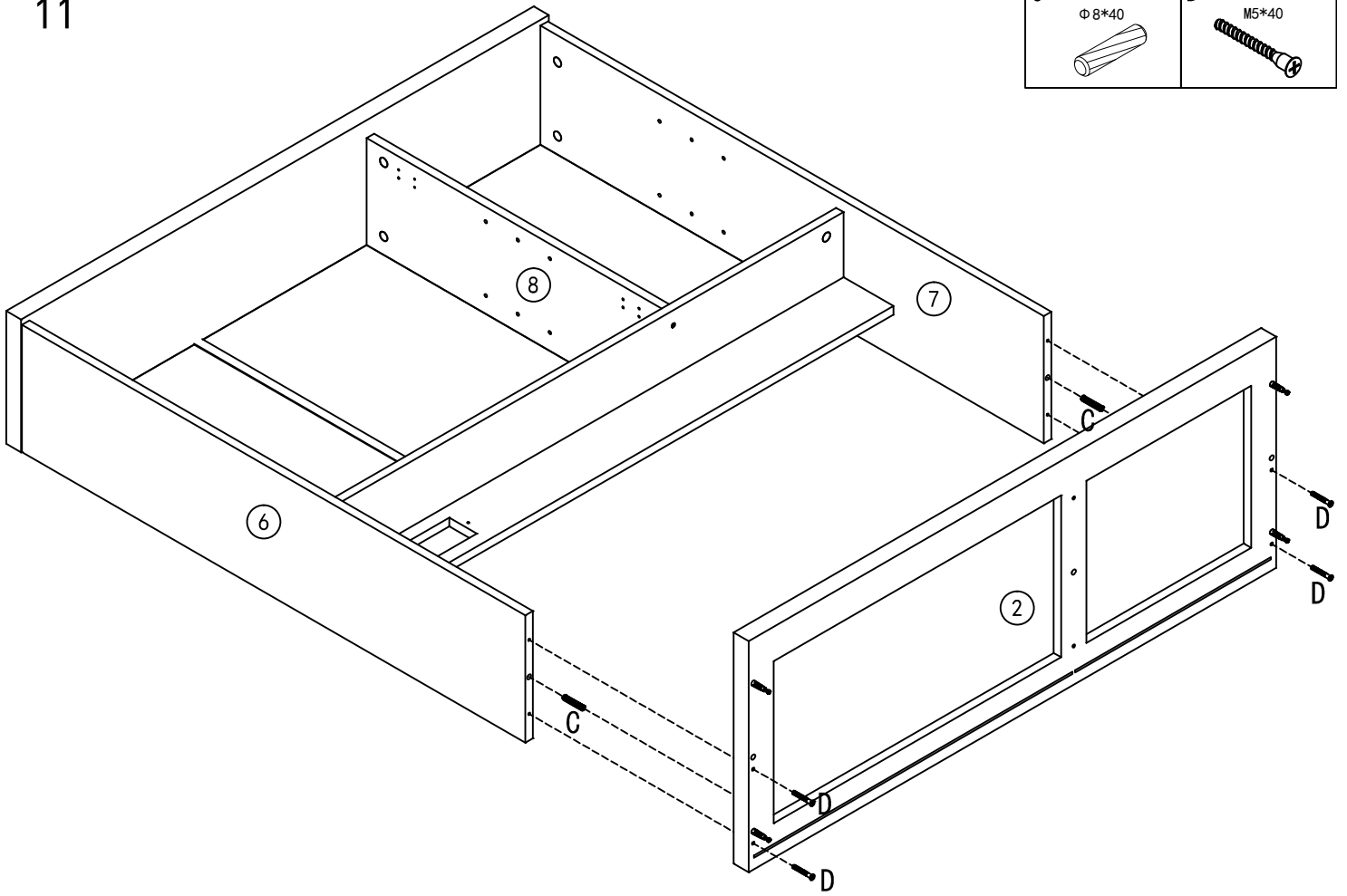

11

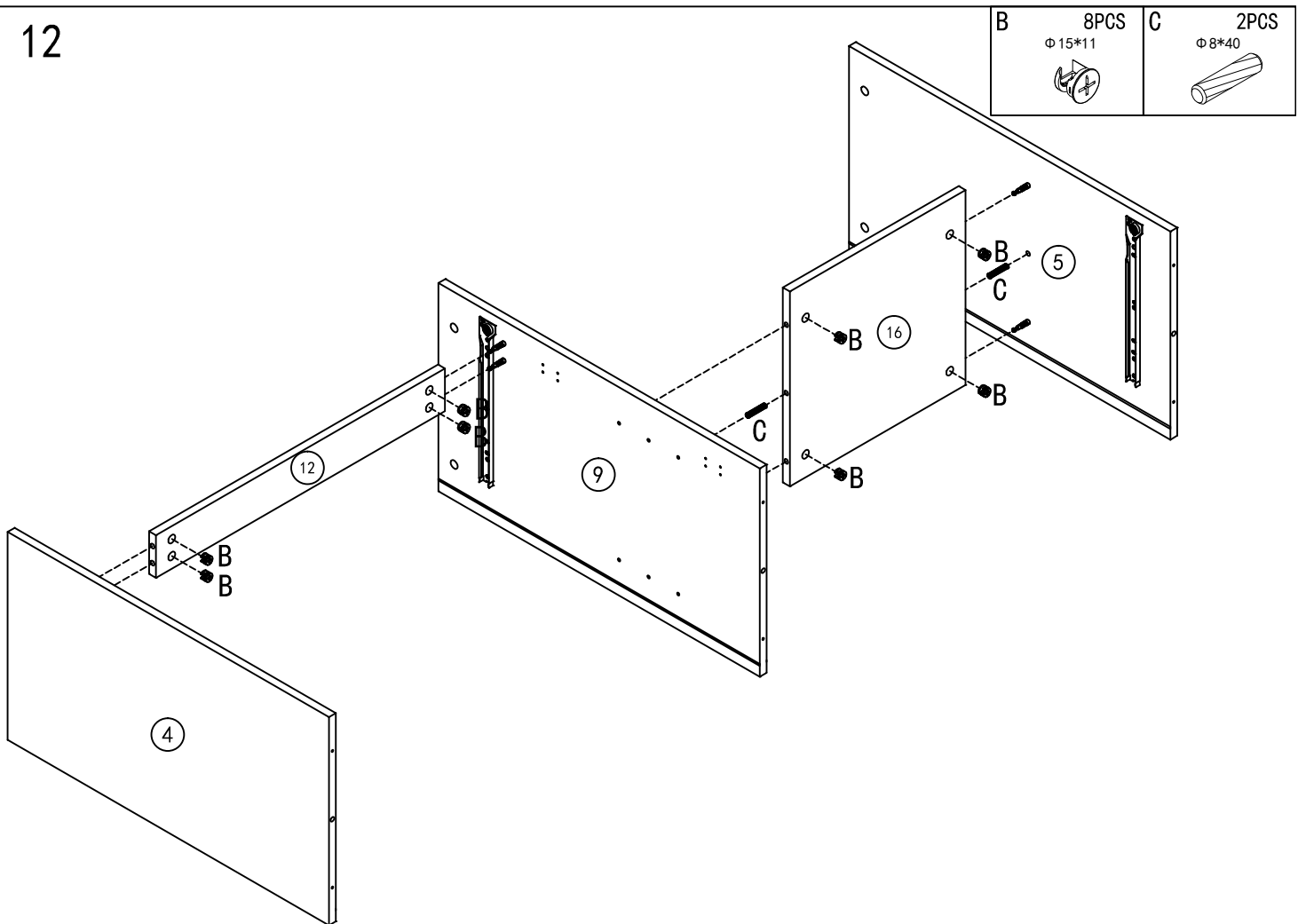

12



13

<b>B</b>	6PCS	<b>C</b>	3PCS
	Φ 15*11		Φ 8*40
			

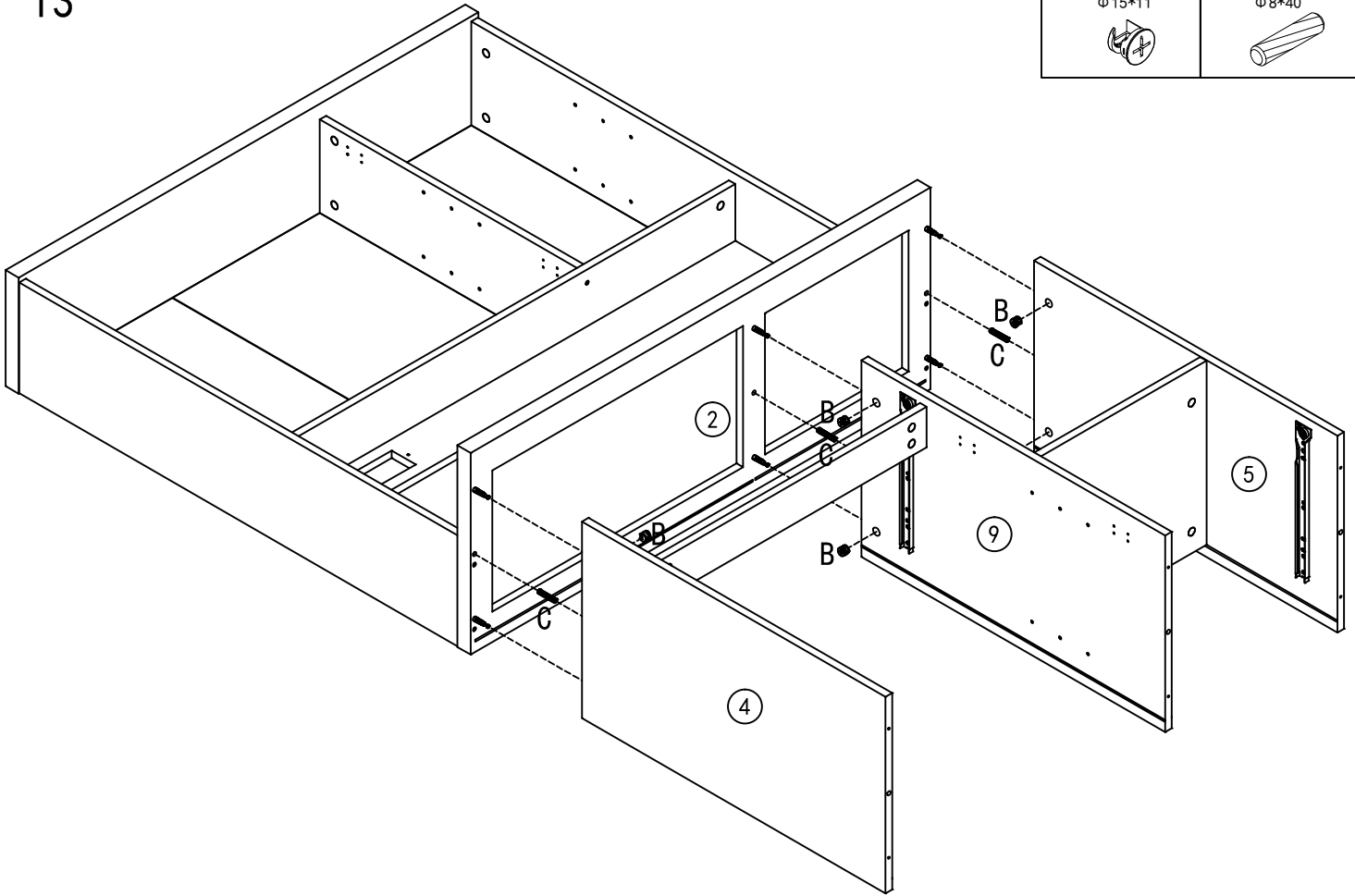

14

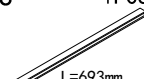
<b>S</b>	1PCS
	L=693mm
	

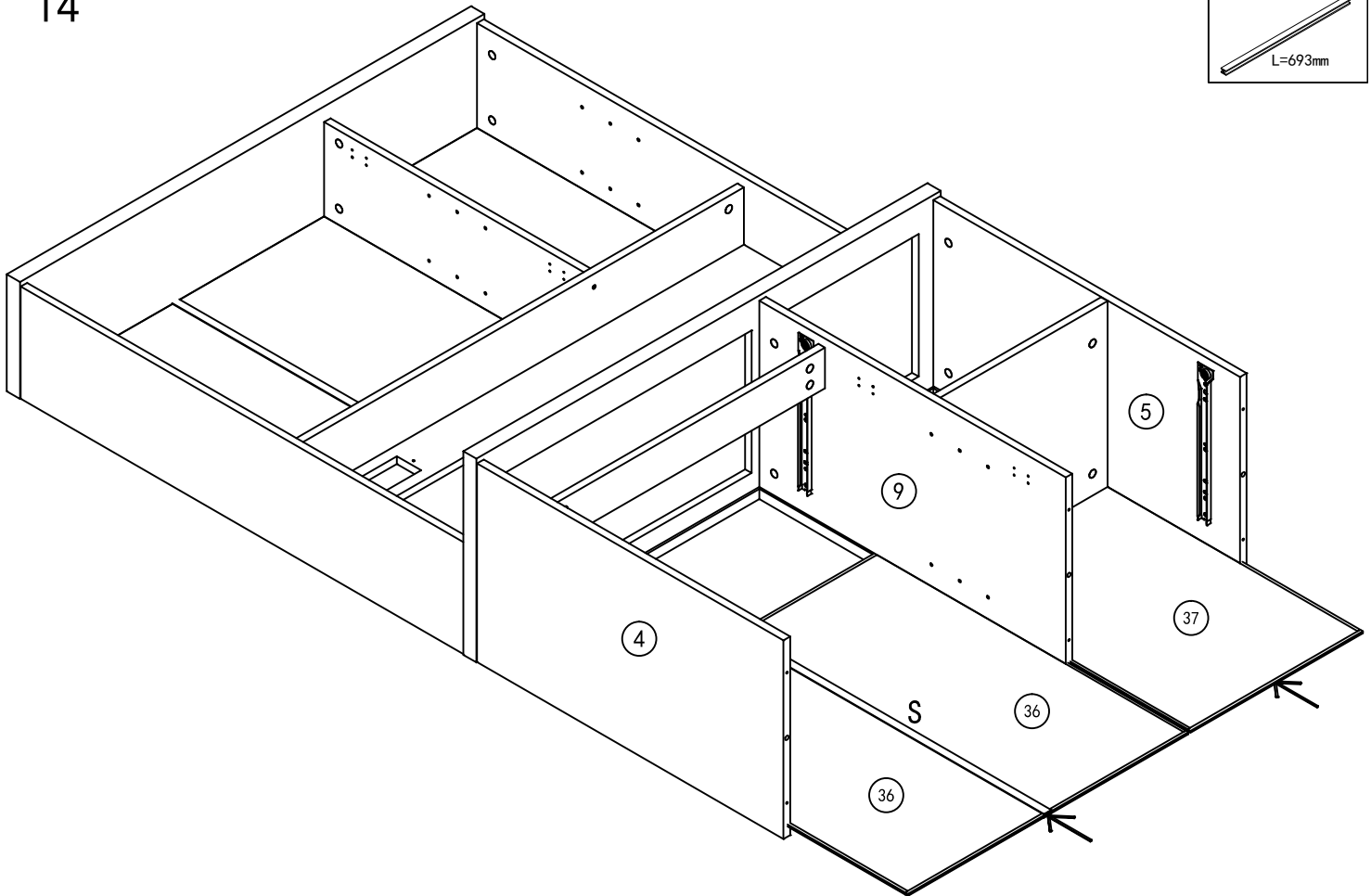

15

<b>C</b>	3PCS Φ 8*40	<b>D</b>	6PCS M5*40
----------	----------------	----------	---------------

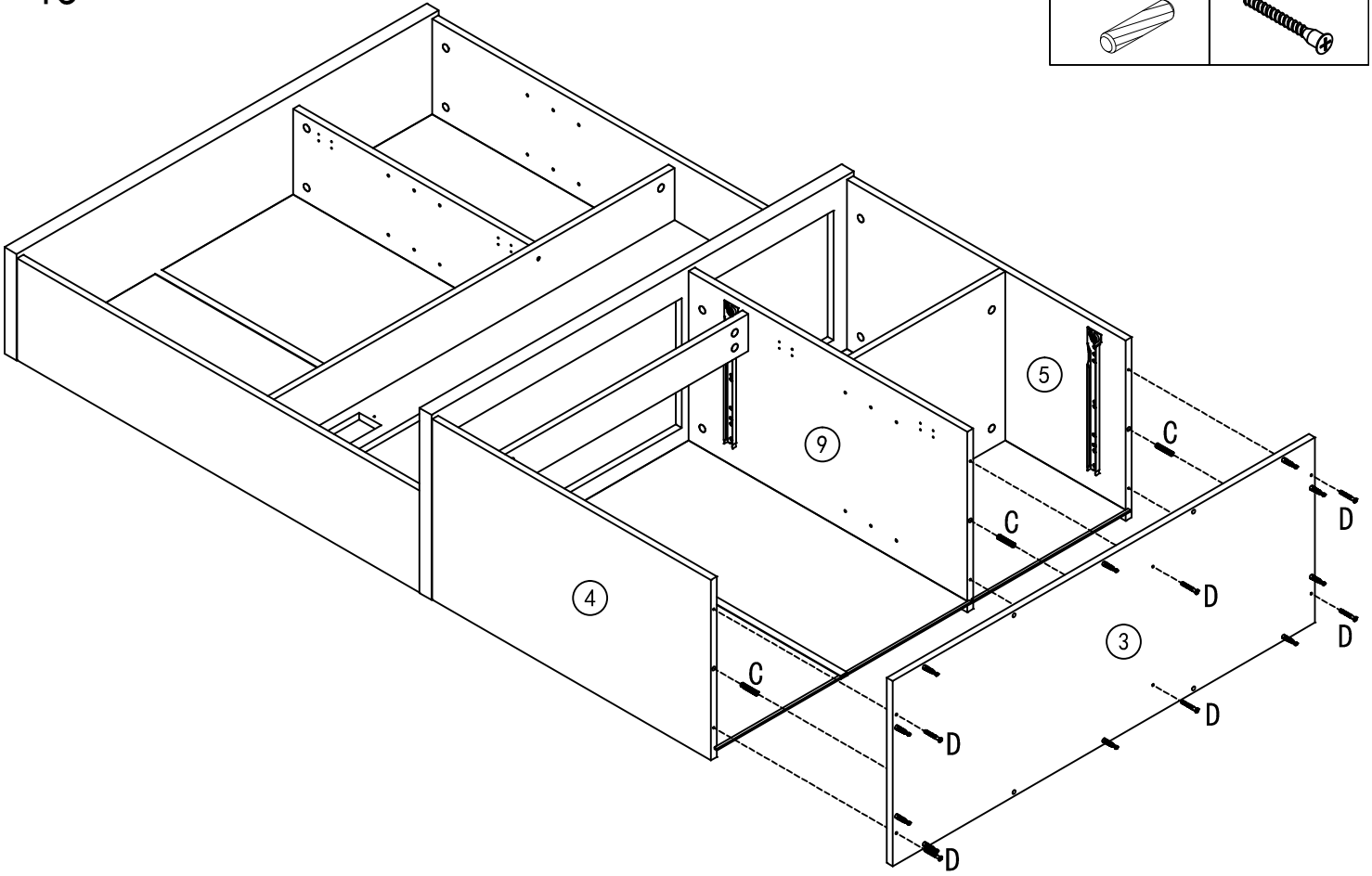

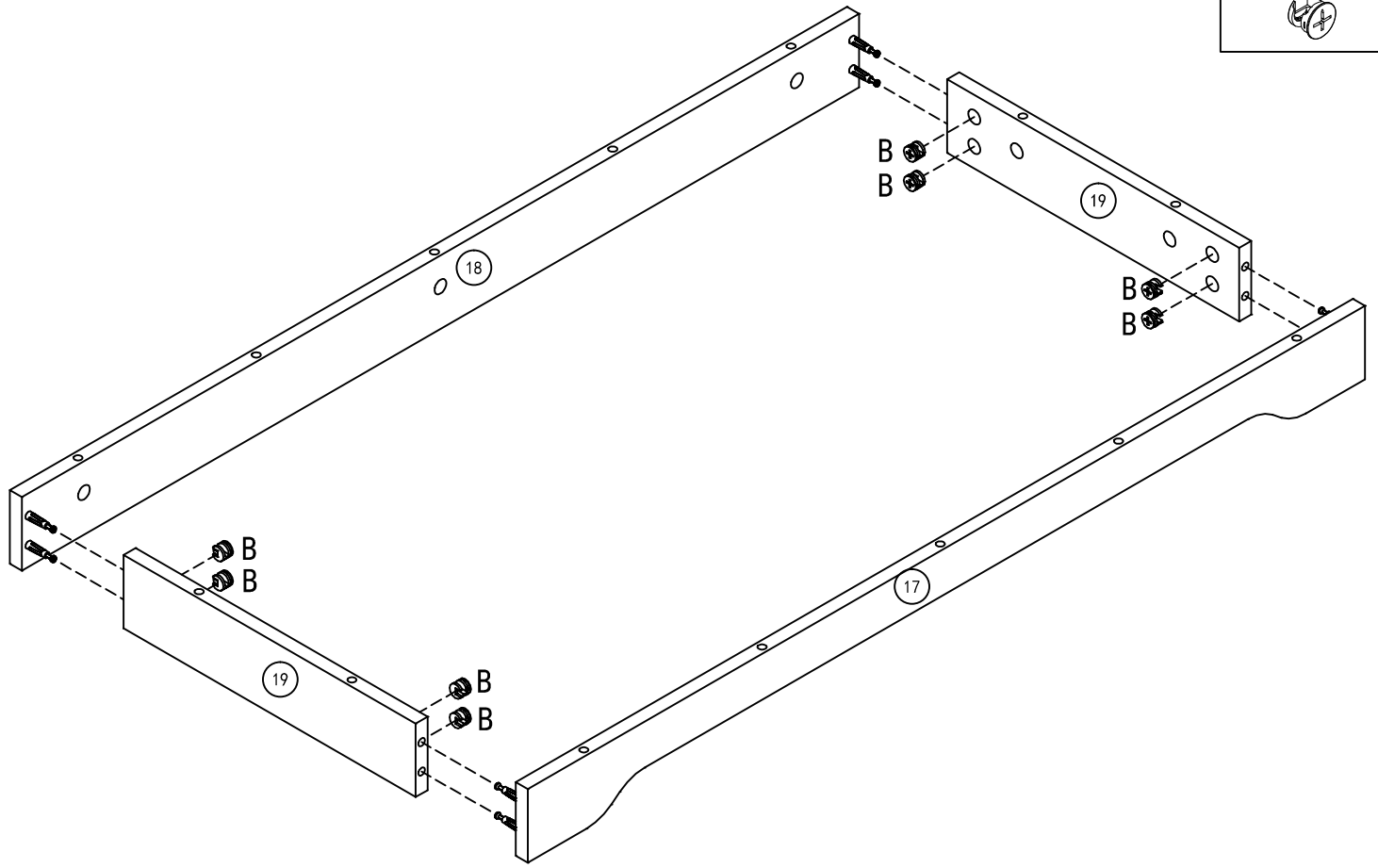

16

<b>B</b>	8PCS Φ 15*11
----------	-----------------



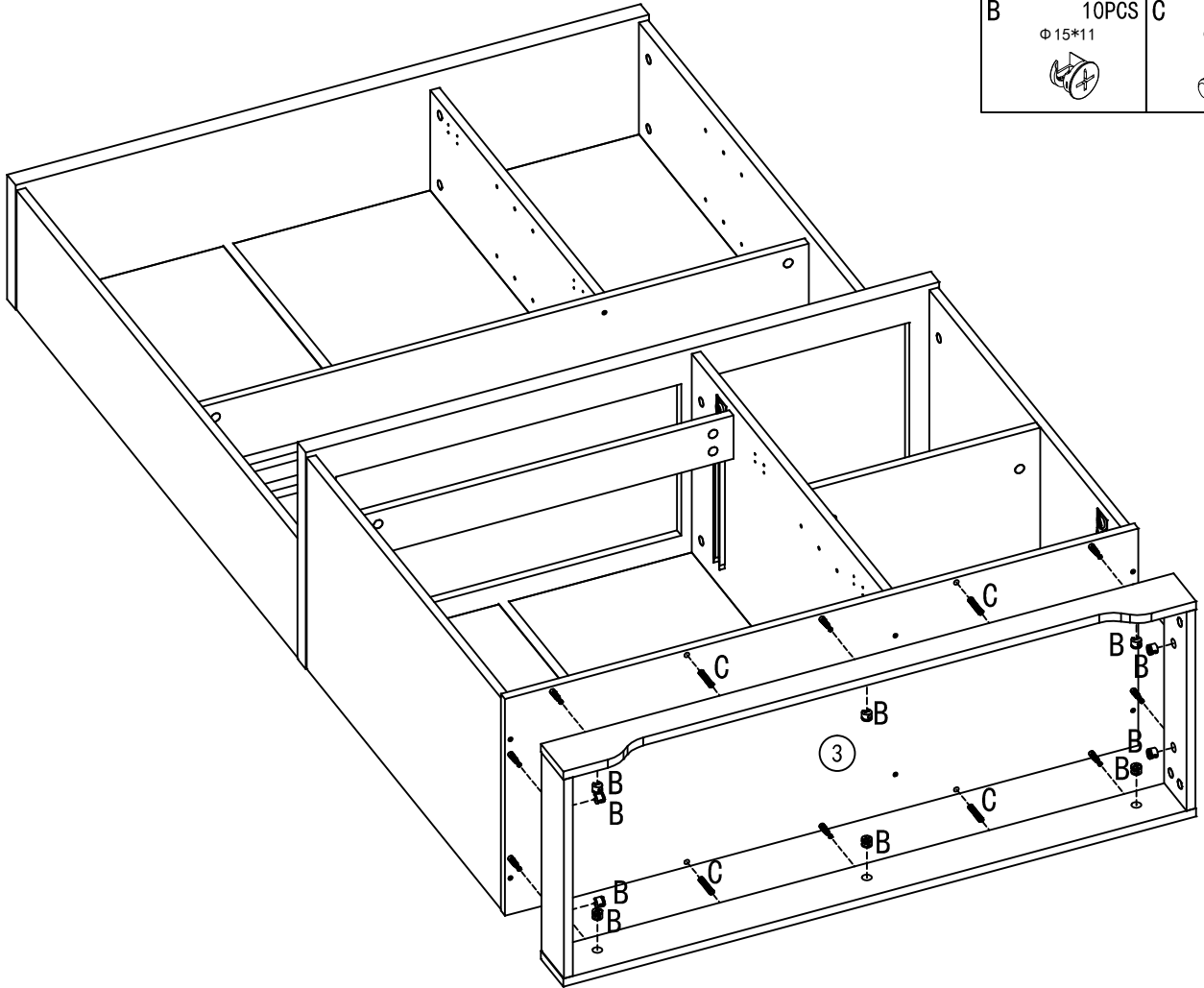

17

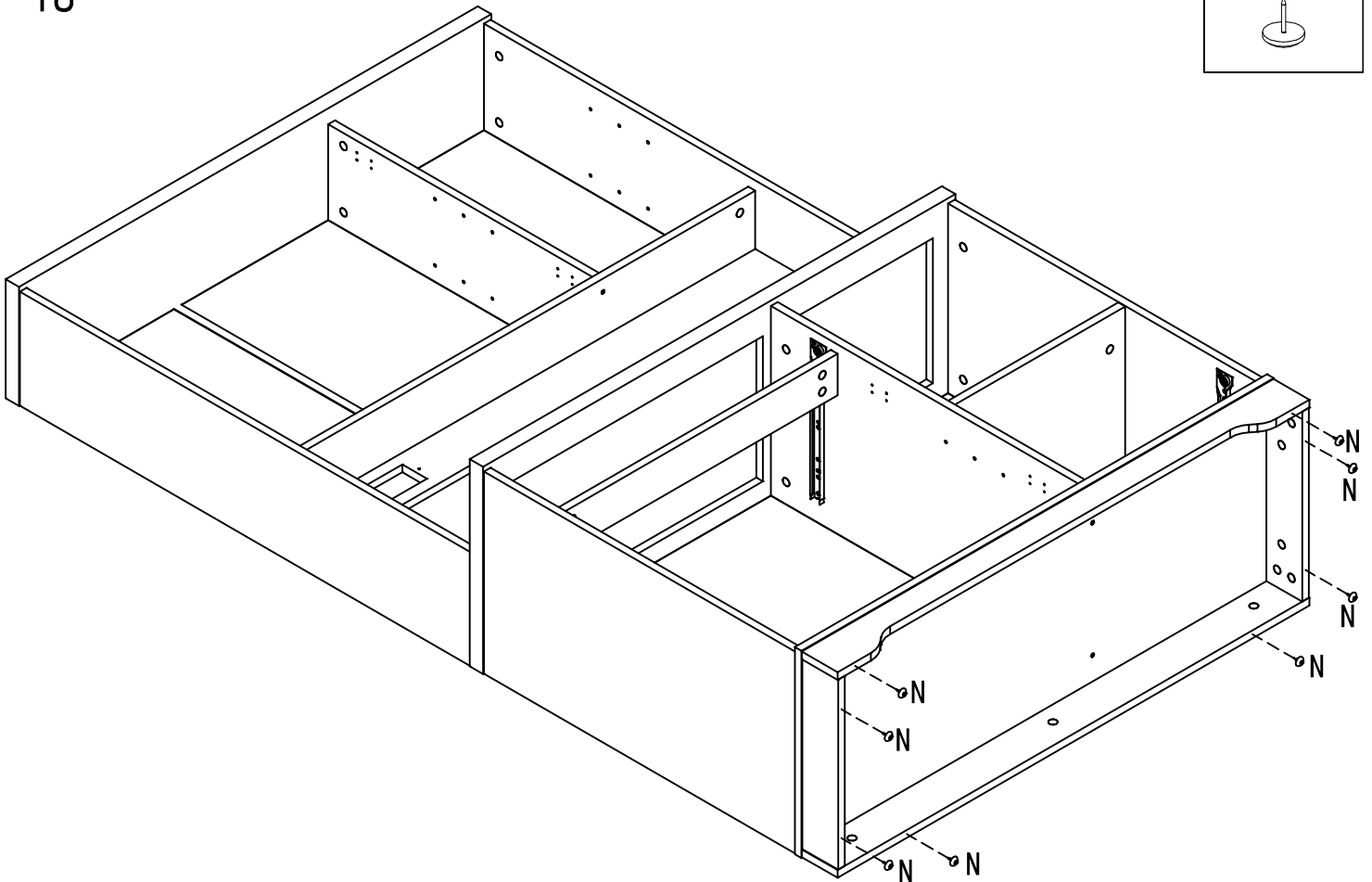

<b>B</b>	10PCS	<b>C</b>	4PCS
	Φ 15*11		Φ 8*40
			

18



<b>N</b>	8PCS
	

19

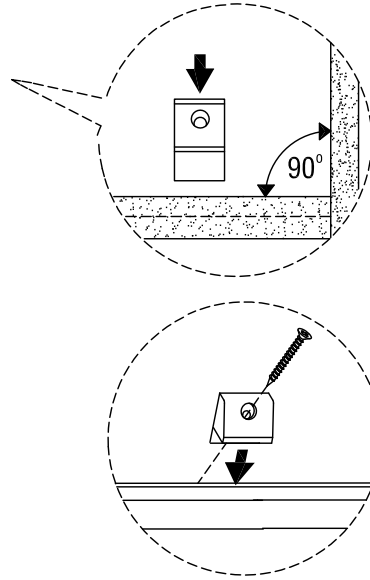
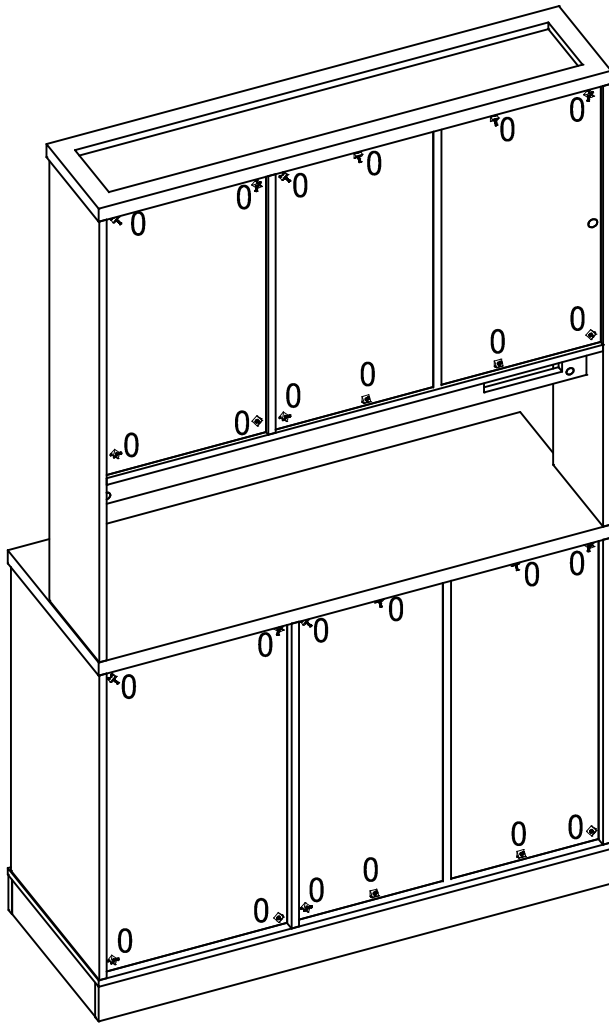

0 24PCS

An icon showing a screw and a screwdriver, representing the hardware for step 19.

20

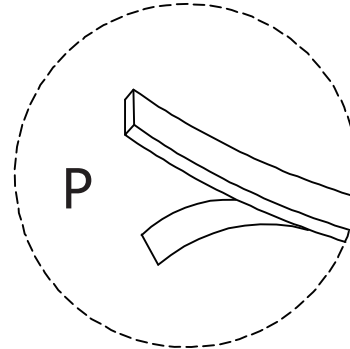
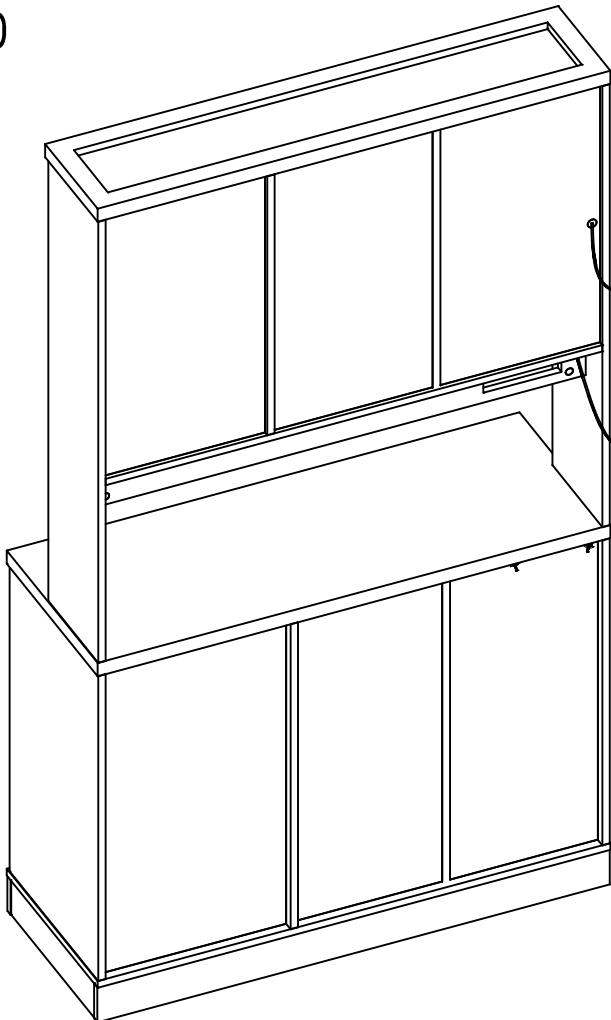

P 1PCS

An icon showing a cable labeled 'P' with a connector, representing the hardware for step 20.

21

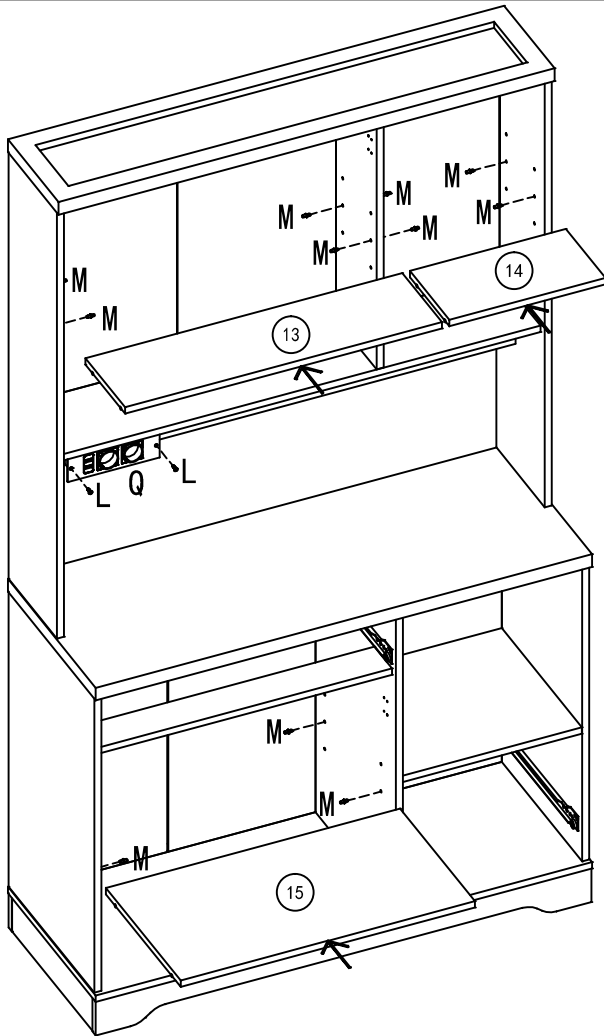

L	2PCS M3.5*14	M	12PCS	Q	1PCS
---	-----------------	---	-------	---	------

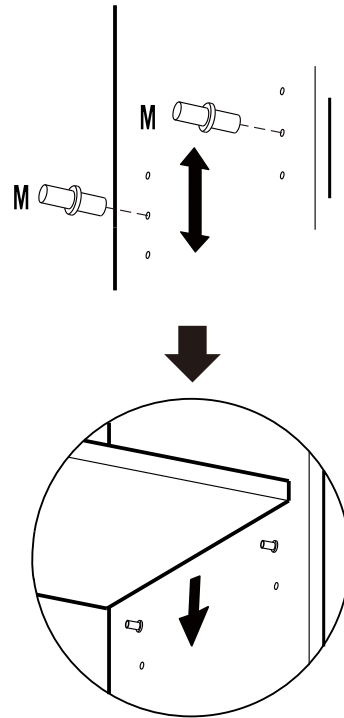

22

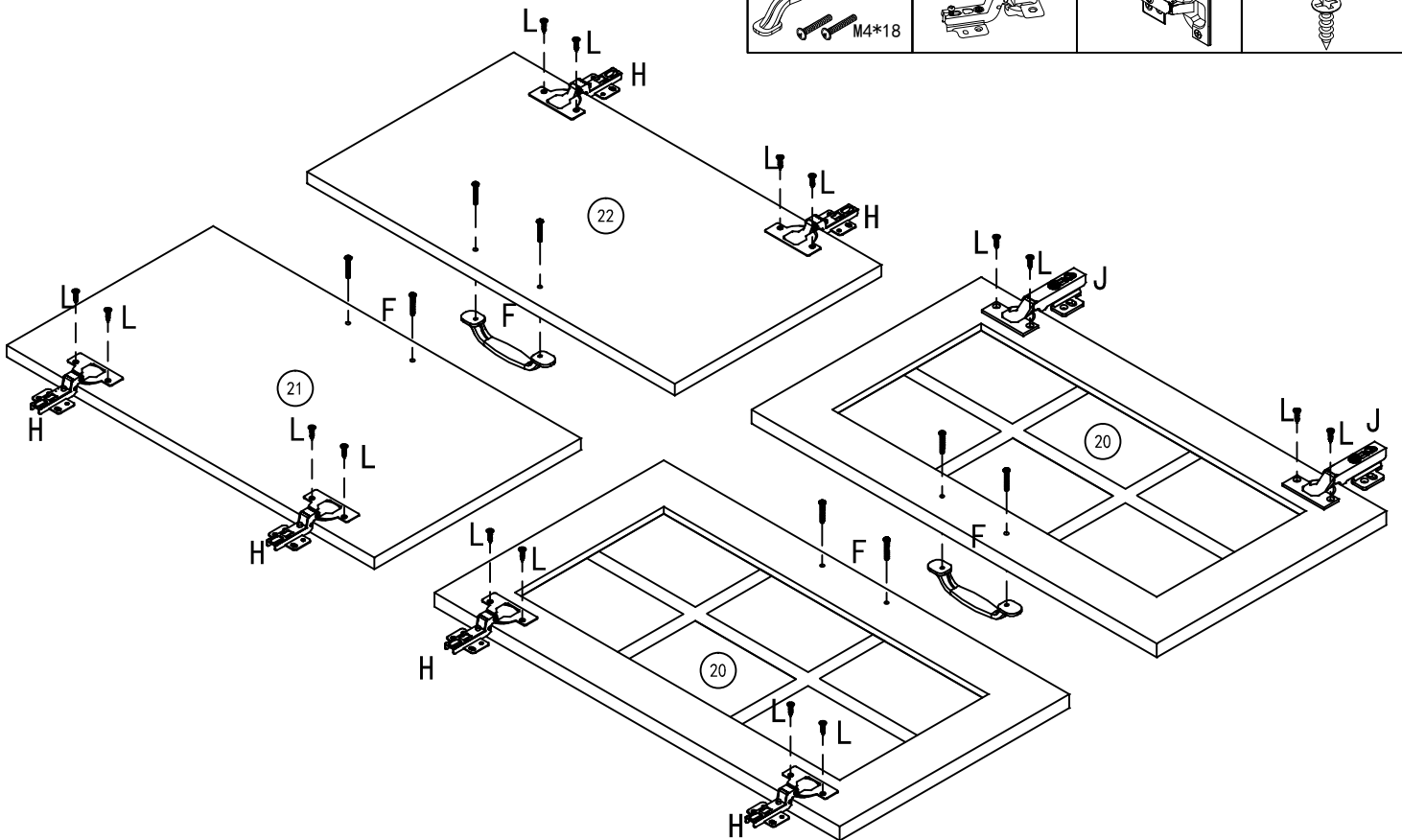

F	4PCS	H	6PCS	J	2PCS	L	16PCS M3.5*14
---	------	---	------	---	------	---	------------------

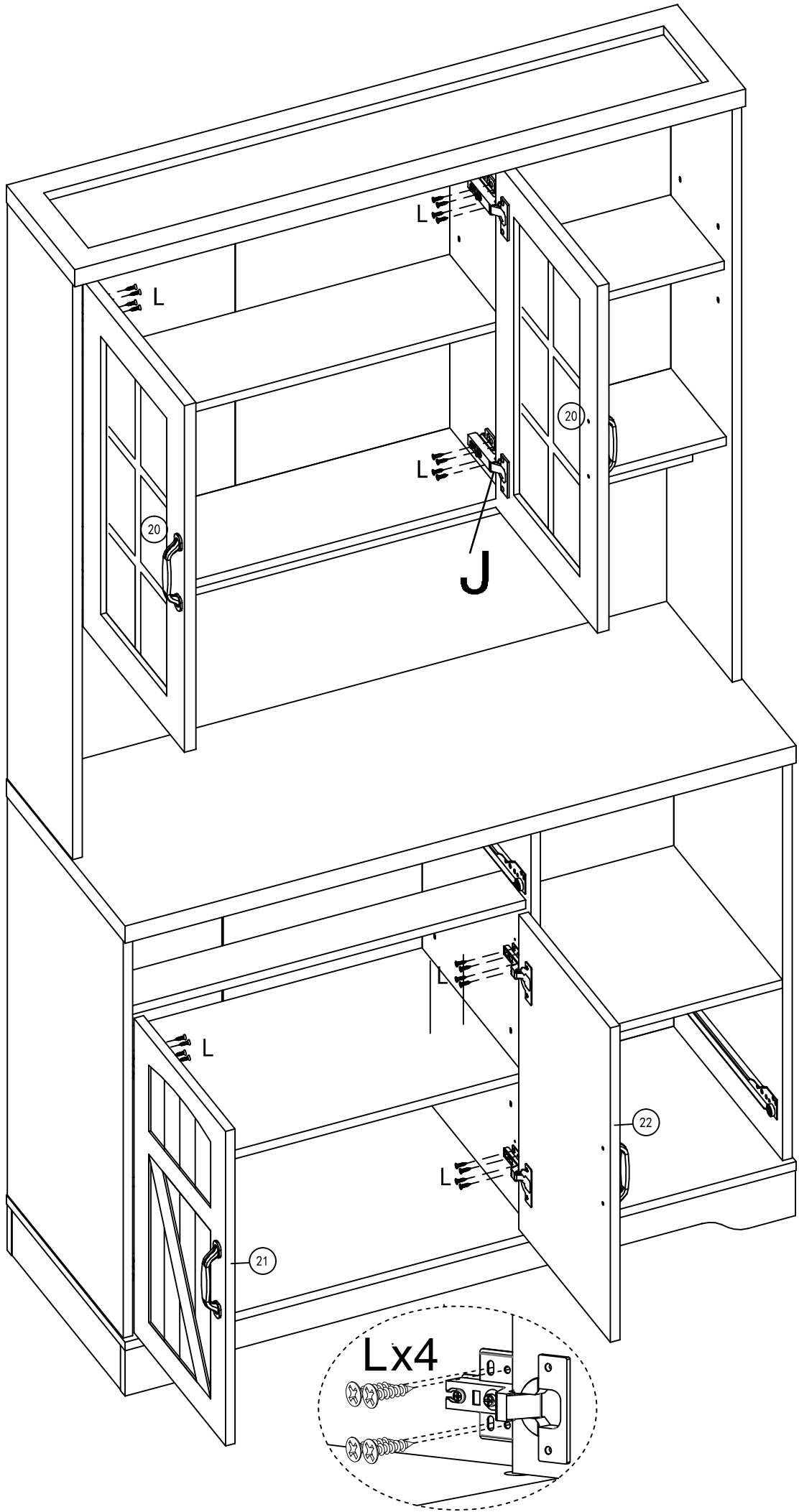

24

<b>B</b>	1PCS Φ 15*11	<b>K</b>	4PCS M4*35

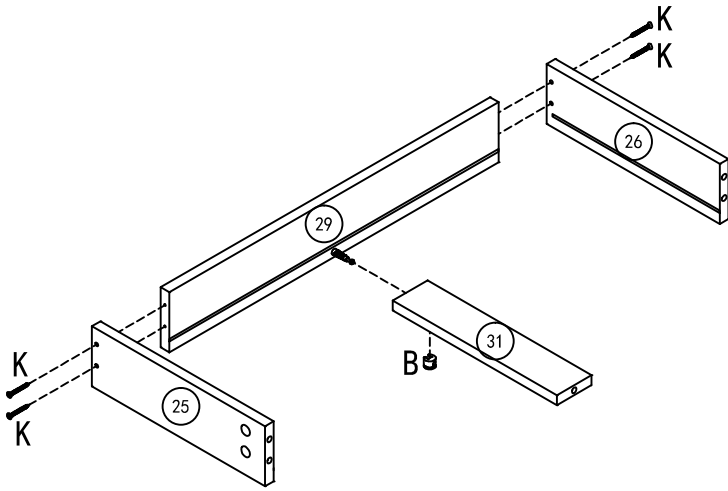

25

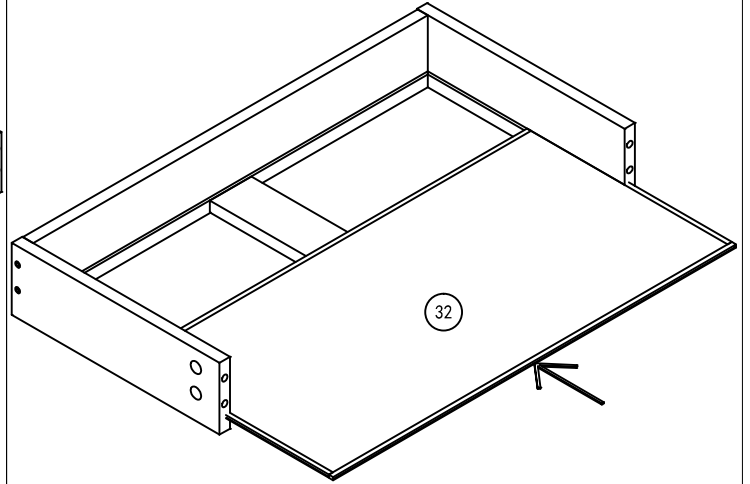

26

<b>B</b>	5PCS Φ 15*11

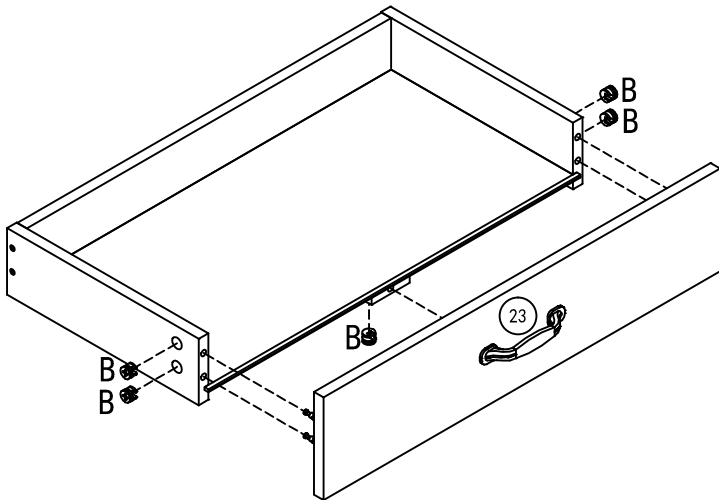

27

<b>E</b>	1SET	<b>L</b>	4PCS M3.5*14

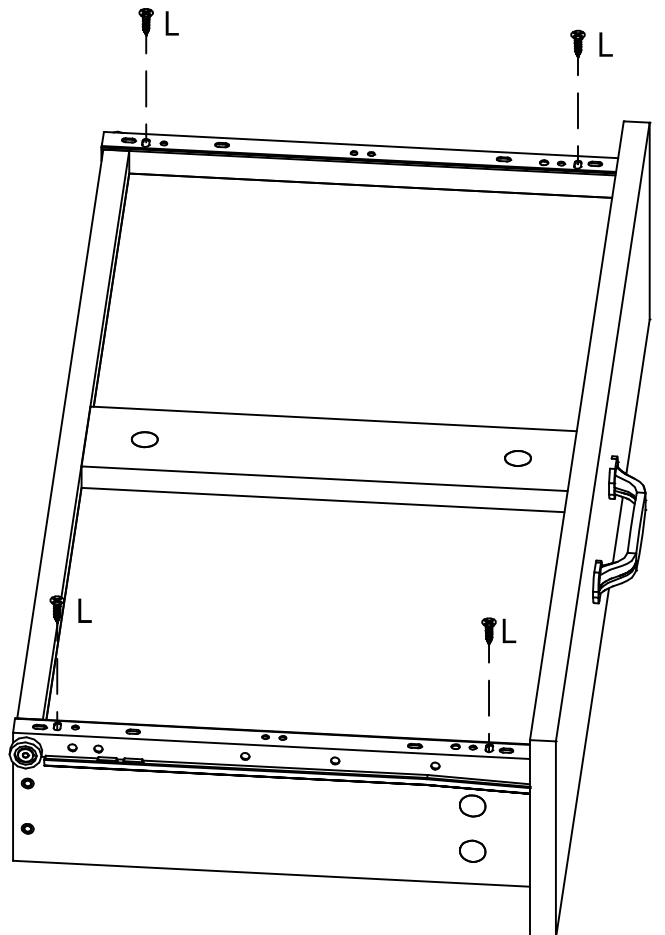

28

K 4PCS  
M4\*35

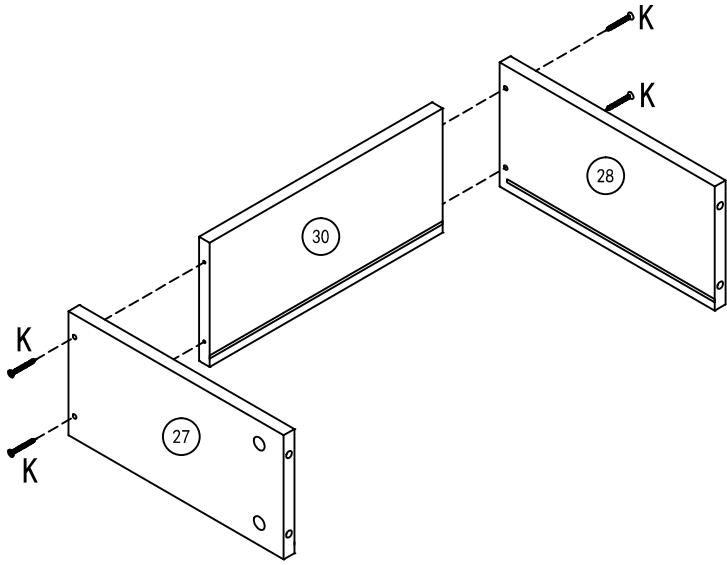

29

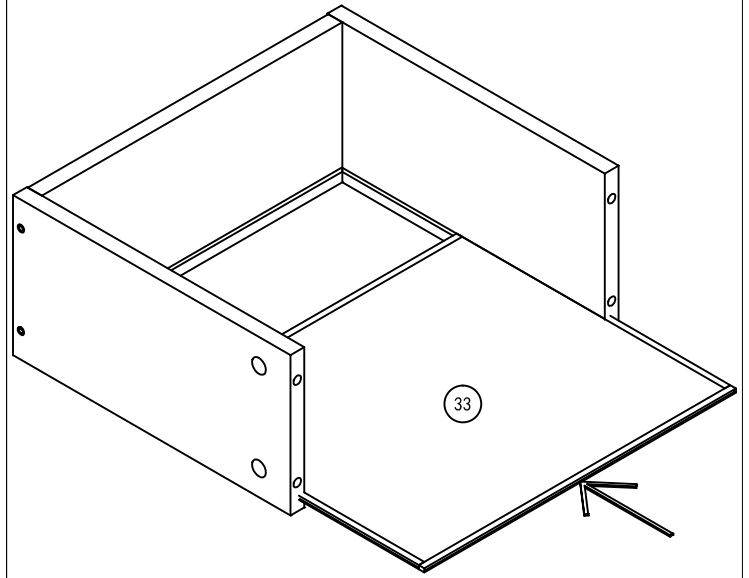

30

B 4PCS  
Φ 15\*11

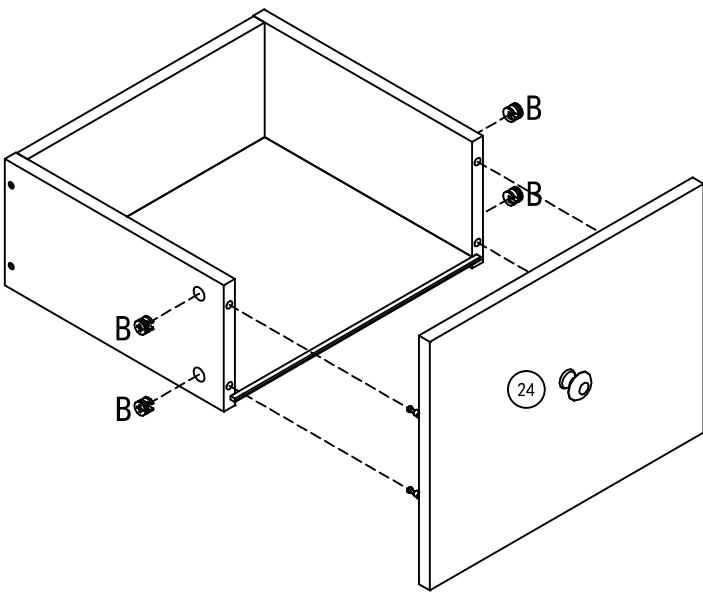

31

E 1SET  
DR  
DL  
CR  
CL

L 4PCS  
M3.5\*14

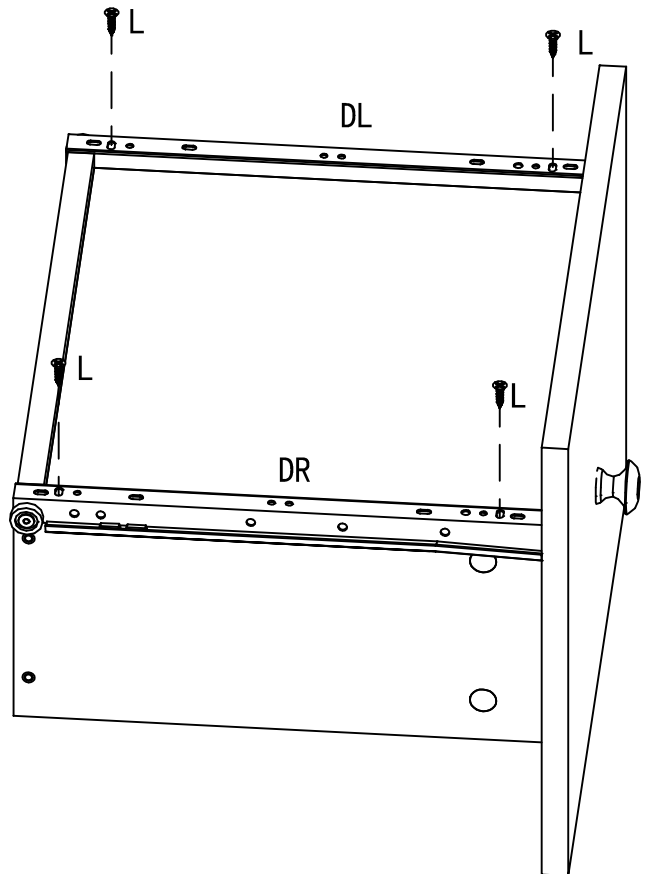

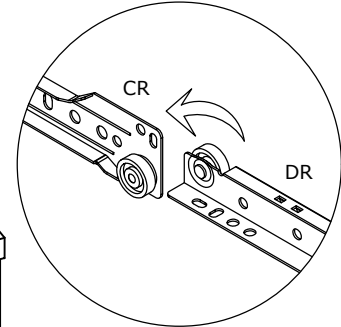
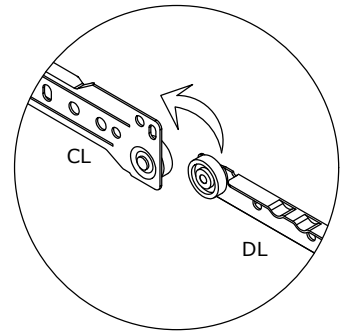
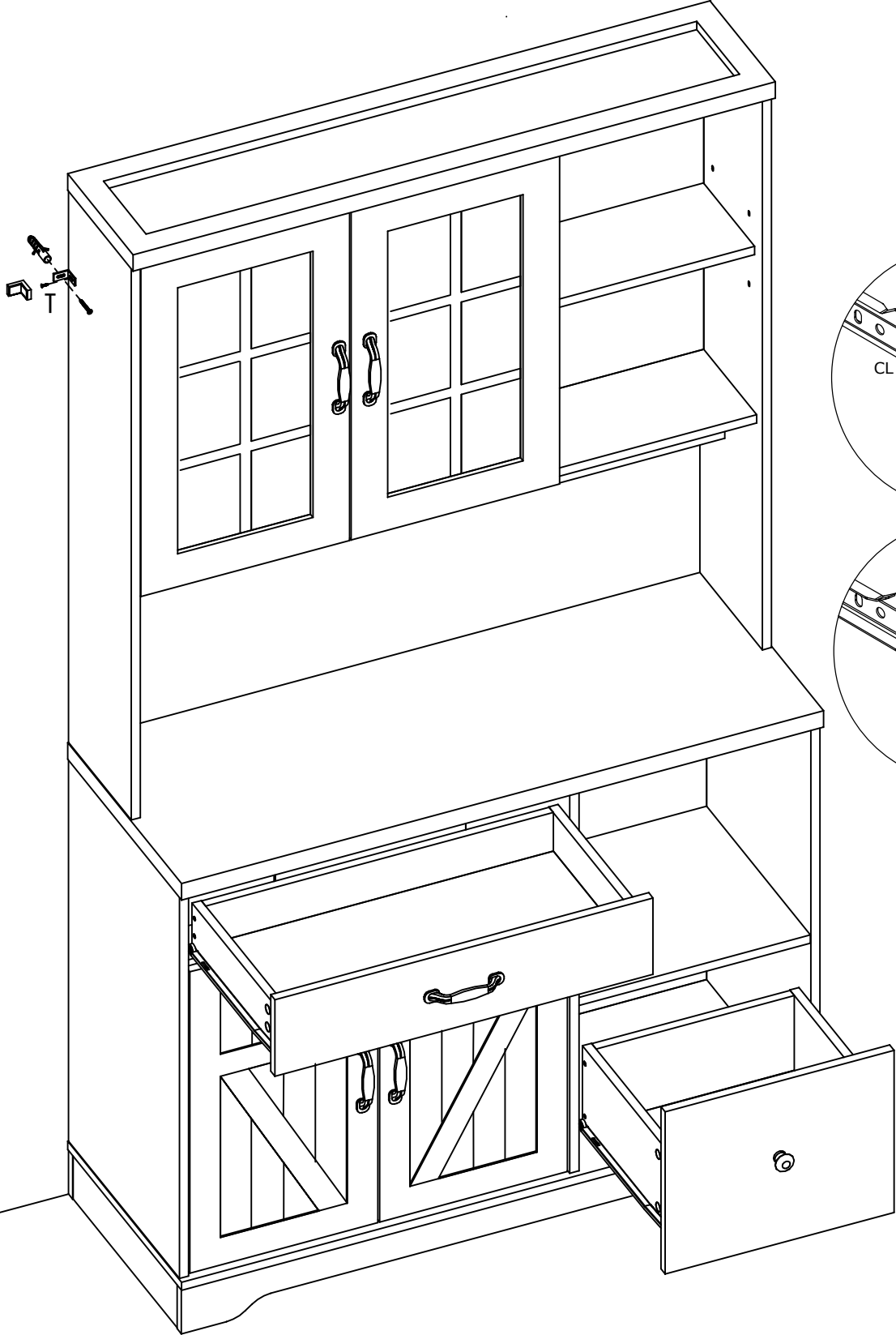
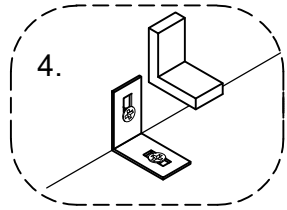
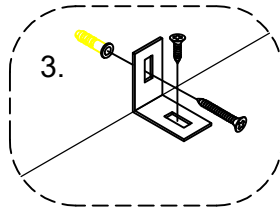
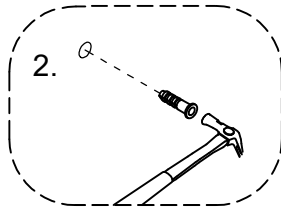
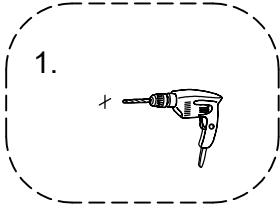
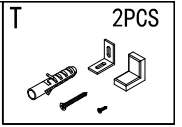

Reference No. : WTN22D07148186Z  
Applicant : Guangdong Zhangong Electric Technology Co., Ltd.  
Address : Room 701, Building 29, Shunde Zhifu Park, No.8, 2nd Ring Road, Gaozan village committee, Xingt an town, Shunde District, Foshan City, Guangdong Province  
Manufacturer : The same as above  
Address : The same as above  
Product : Power Strip  
Model No. : See model list  
Technical data : Input:250V~, 50/60Hz, 16A USB Output:DC 5V,2.0A



#### Test Standards:

DIN VDE 0620-1(VDE 0620-1) : 2019

The above product has been tested by us with the listed standards and found in compliance with the European Directive LVD 2014/35/EU. It is possible to use CE marking to demonstrate the compliance with this LVD Directive.

#### Plugs and socket-outlets for household and similar purposes Part 1: General requirements

The referred test report(s) show that the product complies with standard(s) recognized as giving presumption of compliance with the essential requirements in the above mentioned EU Directive. Other relevant Directives have to be observed.

After preparation of the necessary technical documentation as well as the EU Declaration of Conformity, the CE marking as shown below can be affixed on the equipment under the sole responsibility of the manufacturer.



Manager: Deval Qin  
Date:2022-8-25

The statement is based on a single evaluation of the sample of above mentioned product. It does not imply an assessment of the whole production.

#### Waltek Testing Group Co., Ltd.

Hotline:400-840-2288

E-mail:info@waltek.com.cn

Http://www.waltek.com.cn

Ver.02. 29.07.2022, WALTEK is registered trademark. Utilisation and application requires prior approval.

# Attachment

## Model list



Reference No.: WTN22D07148186Z

Model list

Product name	Model Name	Description
Power Strip	G-PDUM0/12A/15A	250V~ 16A, IP20, Class I, with multi-ways DIN49440-1 socket-outlets with shutter, with USB output, with a non-rewirable plug with cord H05VV-F 3G1,5mm2.
	ZG-PDUG1/10A/16A	
	ZG-PDUG2/10A/16A	
	ZG-PDUG3/10A/16A	
	ZG-PDUG4/10A/16A	
	ZG-PDUF/10A/16A	
	ZG-PDUW1/10A/16A	
	ZG-PDUW2/10A/16A	
	ZG-PDUB/10A/16A	
	ZG-PDUC3/10A/15A	
	ZG-PDUC9/10A/15A	
	ZG-PDUA/10A/15A	
	ZG-PDUY/10A/15A	
	ZG-JJ/12A/15A	
	ZG-HG/12A/15A	
	ZG-ZJ/12A/15A	
	ZG-SJ/12A/15A	
	ZG-DQ/12A/15A	
ZG-PC/12A/15A		
ZG-PDU J00/10A/16A		

=====End of Attachment=====

**Waltek Testing Group Co., Ltd.**

Hotline:400-840-2288

E-mail:info@waltek.com.cn

Http://www.waltek.com.cn

Ver.02. 29.07.2022, WALTEK is registered trademark. Utilisation and application requires prior approval.

# Verification of Compliance

Verification No.:	TMC210319126-E
Name and address of Applicant:	<b>Shenzhen CWG Technology Co., Ltd</b> 5 / F, No.264 Baoshi East Road, Shiyan street, Bao'an District, Shenzhen,China 518108
Name and address of Manufacturer	<b>Shenzhen CWG Technology Co., Ltd</b> 5 / F, No.264 Baoshi East Road, Shiyan street, Bao'an District, Shenzhen,China 518108
Product name:	<b>LED Strip</b>
Rated:	DC12V
Product model(s):	CWG-5050RGB-60D-12V , additional models reference attachment
Product trademark:	创唯光

This verification confirms that the product meets the requirements of the following standard. The conformity was demonstrated based on following standard(s) listed by European Commission as harmonized with EMC Directive 2014/30/EU.

EN IEC 55015:2019+A11:2020  
IEC 61547:2020

*The verification has been carried out in accordance with individual rules and conditions agreed with the applicant. Evaluation has been carried out in accordance with:*

Test report(s) No.:	TMC210319126-E
Test conducted by:	TMC Testing Services (Shenzhen) Co., Ltd.
Verification issue date:	March 26, 2021

**Notes:**

*This verification refers to the above mentioned product and its conformity in regards of above mentioned standard(s) was proven on test sample.*

*This verification does not imply meeting all essential requirements, assessment of the series-production or any other restricted Notified Bodies conformity assessment procedure appropriate for the product.*

*This verification holder shall use this verification in connection to verification of conformity and technical data relevant for the product the verification was issued.*

**TMC Testing Services (Shenzhen) Co., Ltd.**

t:86-755-86642861 cert@tmc-lab.com www.tmc-lab.com

1st Floor, Block A1, Zone A, Xinshidai Gongrong Industrial Park, No. 2, Shihuan Road, Shiyan Street, Baoan District, Shenzhen, China



**Lab Director**  
Lemon Rao



## Verification of Compliance

CWG-5050RGB-30D-12V, CWG-5050RGB-18D-12V, CWG-5050RGB-60D-24V,  
CWG-5050RGB-60D-5V, CWG-5050RGB-30D-5V, CWG-5050RGB-18D-5V,  
CWG-5050-60D-12V, CWG-5050-30D-12V, CWG-5050-60D-24V,  
CWG-HC5050RGB-60D-12V, CWG-HC5050RGB-30D-12V,  
CWG-HC5050RGB-60D-24V, CWG-HC5050-60D-12V, CWG-HC5050-30D-12V,  
CWG-HC5050-60D-24V, CWG-HC5050RGB-30D-5V, CWG-HC5050RGB-60D-5V,  
CWG-HC5050RGB-144D-5V, CWG-2835-60D-12V, CWG-2835-120D-12V,  
CWG-2835-60D-24V, CWG-2835-120D-24V, CWG-2835-60D-5V, CWG-2835-120D-5V

Note:

This attachment only valided with Verification No.: TMC210319126-E



# Attestation of Compliance

Attestation No. : LCS220317036AE

Approval Holder : Dongguan Yihong Hardware Electronics Co., Ltd

Address : Room 1106, No.2, Shangheng Road, Chang' an Town, Dongguan

Manufacturer : Dongguan Yihong Hardware Electronics Co., Ltd

Address : Room 1106, No.2, Shangheng Road, Chang' an Town, Dongguan

Brand Name : YH

Product : Bluetooth 2.4G remote controller

Type/Model Name : YH-284,YH-290,YH-287,YH-358,YH-360

H/S Version : HW: /  
SW: /

Attestation of the technical design of the radio equipment according to the following essential requirements set out in article 3 of the RED 2014/53/EU:

Article 3.1a): Health and Safety **Conform**

Article 3.1b): Electromagnetic Compatibility **Conform**

Article 3.2: Effective Use of the Radio Spectrum **Conform**

CE-marking



Marking Example (Class 1)

This attestation is issued in accordance with the Directive 2014/53/EU of the European Parliament and of the Council of 16 April 2014 on the harmonisation of the laws of the Member States relating to the making available on the market of radio equipment.

April 28, 2022

-----  
Date of issue



-----  
Manager

Shenzhen LCS Compliance Testing Laboratory Ltd.  
Room 101, 201, Building A and Room 301, Building C, Juji Industrial Park, Yabianxueziwei, Shajing Street, Bao'an District, Shenzhen, Guangdong, China  
Tel: (86)755-82591330 Fax: (86)755-82591332  
Http://www.LCS-cert.com Email: webmaster@LCS-cert.com



# Annex



## Applied Standards and Test Reports

Standard	Laboratory	Test Report Number
ETSI EN 301 489-1 V2.2.3 (2019-11) Final draft ETSI EN 301 489-3 V2.2.0 (2021-11) ETSI EN 301 489-17 V3.2.4 (2020-09) EN 55032:2015/A11:2020 EN 55035:2017+A11:2020	Shenzhen LCS Compliance Testing Laboratory Ltd.	LCS220317036AEA
ETSI EN 300 328 V2.2.2 (2019-07)	Shenzhen LCS Compliance Testing Laboratory Ltd.	LCS220317036AEB
ETSI EN 300 440 V2.2.1 (2018-07)	Shenzhen LCS Compliance Testing Laboratory Ltd.	LCS220317036AEC
EN 62479: 2010 EN 50663: 2017	Shenzhen LCS Compliance Testing Laboratory Ltd.	LCS220317036AED
EN 62368-1:2014+A11: 2017	Shenzhen LCS Compliance Testing Laboratory Ltd.	LCS220317040AS

### General Remarks:

1. This conformity assessment is limited to the essential requirements of the RED Directive. Only products fulfilling all essential requirements of all applicable new approach directives may be placed on the market and put into service.
2. Products in compliance with all provisions of the applicable directives providing for the CE marking must bear this marking.
3. The manufacturer shall take all measures necessary so that the manufacturing process and its monitoring ensure conformity of the manufactured radio equipment with the approved type described in the Attestation of Compliance and with the requirements of Directive 2014/53/EU that apply to it.
4. This device also contains frequency bands that are not operational in EU member states. Only the frequency bands used in European Union have been assessed for this attestation.
5. The manufacturer shall draw up a written EU declaration of conformity for each radio equipment type and keep it at the disposal of the national authorities for 10 years after the radio equipment has been placed on the market. The EU declaration of conformity shall identify the radio equipment type for which it has been drawn up. A copy of the EU declaration of conformity shall be made available to the relevant authorities upon request.





# Attestation of Compliance

Reference No. : LCS220317038AE

Applicant : Dongguan Yihong Hardware Electronics Co., Ltd

Address : Room 1106, No.2, Shangheng Road, Chang' an Town, Dongguan

Trade Mark : YH

Product : Bluetooth 2.4G remote controller

Model(s) : YH-284,YH-290,YH-287,YH-358,YH-360

Tested according to : EN 55032:2015/A11:2020 EN 55035:2017+A11:2020  
EN IEC 61000-3-2:2019/A1:2021 EN 61000-3-3:2013/A2:2021

The submitted products have been tested by us with the listed standards.

This Attestation of Compliance is issued according to the council Directive 2014/30/EU, Referred to as the Electromagnetic Compatibility. It confirms that the listed product complies with all essential requirements of the EMC directive and applies only to the sample and its technical documentation submitted to Shenzhen LCS Compliance Testing Laboratory Ltd. for testing.

After preparation of the necessary technical documentation as well as the EC conformity declaration the required CE marking can be affixed on the product. Other relevant Directives have to be observed.



Date of issue: April 28, 2022



# Verification of Compliance

**Verification No.:** MK25070091P01-C01  
**Name and address of Applicant:** **Shenzhen CWG Technology Co., Ltd**  
 3/F, Building A, Yongshenghui Industrial Park, Chuangye Road, Shiyan Street, Bao'an District, Shenzhen  
**Name and address of Manufacturer:** **Shenzhen CWG Technology Co., Ltd**  
 3/F, Building A, Yongshenghui Industrial Park, Chuangye Road, Shiyan Street, Bao'an District, Shenzhen  
**Product name:** **LED Strip**  
 CWG-5050RGB-60D-5V, CWG-5050RGB-30D-12V, CWG-5050RGB-18D-12V, CWG-5050RGB-60D-24V, CWG-5050RGB-60D-12V, CWG-5050RGB-30D-5V, CWG-5050RGB-18D-5V, CWG-5050-60D-12V, CWG-5050-30D-12V, CWG-5050-60D-24V, CWG-HC5050RGB-60D-12V, CWG-HC5050RGB-30D-12V, CWG-HC5050RGB-60D-24V, CWG-HC5050-60D-12V, CWG-HC5050-30D-12V, CWG-HC5050-60D-24V, CWG-HC5050RGB-30D-5V, CWG-HC5050RGB-60D-5V, CWG-HC5050RGB-144D-5V, CWG-2835-60D-12V, CWG-2835-120D-12V, CWG-2835-60D-24V, CWG-2835-120D-24V, CWG-2835-60D-5V, CWG-2835-120D-5V  
**Product model(s):**  
**Product trademark:** 创唯光

This verification confirms that the product meets the requirements of the following standard. The conformity was demonstrated based on following standard(s) listed by European Commission as harmonized with Directive RoHS 2.0 Directive (EU) 2015/863 and (EU)2017/2102 amending Annex II to Directive 2011/65/EU

IEC 62321-1:2013	IEC 62321-3-1:2013
IEC 62321-4:2013/AMD1:2017	IEC 62321-5:2013
IEC 62321-6:2015	IEC 62321-7-1:2015
IEC 62321-7-2:2017	IEC 62321-8:2017
IEC 62321-2:2021	

The verification has been carried out in accordance with individual rules and conditions agreed with the applicant. Evaluation has been carried out in accordance with:

**Test report(s) No.:** MK25070091P01-C01  
**Test conducted by:** TMC Testing Services (Shenzhen) Co., Ltd.  
**Verification issue date:** July 17, 2025

**Notes:**

This verification refers to the above mentioned product and its conformity in regards of above mentioned standard(s) was proven on test sample.

This verification does not imply meeting all essential requirements, assessment of the series-production or any other restricted Notified Bodies conformity assessment procedure appropriate for the product.

This verification holder shall use this verification in connection to verification of conformity and technical data relevant for the product the verification was issued.

**TMC Testing Services (Shenzhen) Co., Ltd.**

t:86-755-86642861 cert@tmc-lab.com www.tmc-lab.com

1st Floor, Block A1, Zone A, Xinshidai Gongrong Industrial Park, No. 2, Shihuan Road, Shiyan Street, Baoan District, Shenzhen, China



**Lab Director**  
 Vivian Jiang





# Certificate of Compliance

**Certificate Number: BOKE-251211102C01C**

**Certificate's Holder** : Guangdong Zhangong Electric Technology Co., LTD  
**Zertifikatsinhaber** : 701, Building 29, zhifuyuan Industrial Zone, Xingtang town, Shunde District, Foshan City, Guangdong Province

**Manufacturer** : Guangdong Zhangong Electric Technology Co., LTD  
**Hersteller** : 701, Building 29, zhifuyuan Industrial Zone, Xingtang town, Shunde District, Foshan City, Guangdong Province

**Trade Mark** : /  
**Warenzeichen**

**Product** : Furniture socket  
**Produkt**

**Model(s)** : ZG-JJO-B2A-2A  
**Bezeichnung** : ZG-JJO-B2B-2A, ZG-PDU J00, ZG-PDU JOO/10A/16A, ZG-JJY-1UK to -8UK, ZG-JJM/12A/15A, ZG-JJM, LH-D, ZG-JJM-A2, ZG-JJM1-A2

**Test Standard** : IEC 62321-3-1:2013, IEC 62321-4:2013+A1:2017, IEC 62321-5:2013,  
**Geprüft nach** : IEC 62321-6:2015, IEC 62321-7-1:2015, IEC 62321-7-2:2017, IEC 62321-8:2017

**Test Report No.** : BOKE-251211102C01  
**Bericht Nr**

The EUT described above has been consolidated by us and found in compliance with the council RoHS Directive 2011/65/EU Annex II amending Annex (EU)2015/863. The essential requirements are fulfilled accordingly based on the technical specifications applicable at the time of issuance. It is only valid in connection with the test report.

After preparation of the necessary technical documentation according the Requirement of EN IEC 63000:2018 as well as the verification of conformity the CE marking as shown below can Be affixed on the equipment.



Shenzhen Boke Testing Co., Ltd.

Address: 501, Building 1, No. 21, Lianteng Road, Loucun Community, Xinhua Street, Guangming District, Shenzhen, Guangdong, China

Web: <http://www.boke-lab.com> E-mail: [admin@boke-lab.com](mailto:admin@boke-lab.com) Tel: 0755-23056504



Shenzhen ZKT Technology Co., Ltd.  
1/F, No. 101, Building B, No. 6, Tangwei Community Industrial Avenue,  
Fuhai Street, Bao'an District, Shenzhen, China



# Certificate of Compliance

Certificate Number: ZKT-250516L9522C

**Certificate's Holder** : Guangdong Zhangong Electric Technology Co., LTD  
701, Building 29, zhifuyuan Industrial Zone, Xingtan town,  
Shunde District, Foshan City, Guangdong Province

**Manufacturer** : Guangdong Zhangong Electric Technology Co., LTD  
701, Building 29, zhifuyuan Industrial Zone, Xingtan town,  
Shunde District, Foshan City, Guangdong Province

**Trade Mark** : /

**Product** : Furniture socket

**Model(s)** : ZG-JJO-B2A-2A  
ZG-JJO-B2B-2A, ZG-PDU J00

**Test Standard** : EN 55032:2015 + A11:2020 + A1:2020  
EN 55035:2017 + A11:2020  
EN IEC 61000-3-2:2019 + A1:2021 + A2:2024  
EN 61000-3-3:2013 + A1:2019 + A2:2021

This Attestation of Compliance is issued for electrical equipment below the voltage limits of EMC Directive 2014/30/EU. The essential requirements are fulfilled accordingly based on the technical specifications applicable at the time of issuance. It is only valid in connection with the test report. It is only valid in connection with the test report number: ZKT-250516L9522E.



This Certificate of Conformity is based on single evaluation of the submitted sample(s) of the above mentioned product. It does not imply an assessment of the whole product and relevant Directives to be observed.

Shenzhen ZKT Technology Co., Ltd.

1/F, No. 101, Building B, No. 6, Tangwei Community Industrial Avenue,  
Fuhai Street, Bao'an District, Shenzhen, China



# Certificate of Compliance

Certificate Number: ZKT-250516L9523C

- Certificate's Holder** : Guangdong Zhangong Electric Technology Co., Ltd  
701, Building 29, zhifuyuan Industrial Zone, Xingtan town,  
Shunde District, Foshan City, Guangdong Province
- Manufacturer** : Guangdong Zhangong Electric Technology Co., Ltd  
701, Building 29, zhifuyuan Industrial Zone, Xingtan town,  
Shunde District, Foshan City, Guangdong Province
- Trade Mark** : /
- Product** : Furniture socket
- Model(s)** : ZG-JJO-B2A-2A, ZG-JJO-B2B-2A, ZG-PDU J00
- Test Standard** : EN 61558-2-16:2009+A1:2013 used in conjunction with  
EN IEC 61558-1:2019

This Attestation of Compliance is issued on a voluntary basis for electrical equipment below the voltage limits of Low Voltage Directive 2014/35/EU. The essential requirements are fulfilled accordingly based on the technical specifications applicable at the time of issuance. See also notes overleaf. It is only valid in connection with the test report number: ZKT-250516L9523S.



This Certificate of Conformity is based on single evaluation of the submitted sample(s) of the above mentioned product. It does not imply an assessment of the whole product and relevant Directives to be observed.