

N621P166802

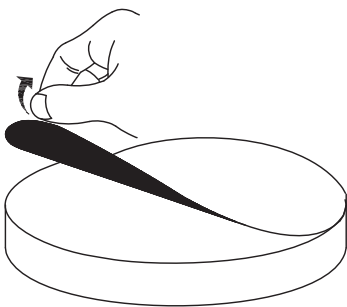

PLEASE NOTE: The table top is covered with a tight plastic protective film. If there are scratches on the product after disassembly, please don't worry, it's not product damage. Please slowly tear off the protective plastic film on the surface along the edge. After peeling off, the product becomes smooth and clean.

BITTE BEACHTEN: Die Tischplatte ist mit einer dichten Kunststoff-Schutzfolie überzogen. Wenn das Produkt nach der Demontage Kratzer aufweist, machen Sie sich bitte keine Sorgen, es handelt sich nicht um Produktschäden. Bitte reißen Sie die Schutzfolie auf der Oberfläche entlang der Kante langsam ab. Nach dem Abziehen wird das Produkt glatt und sauber.

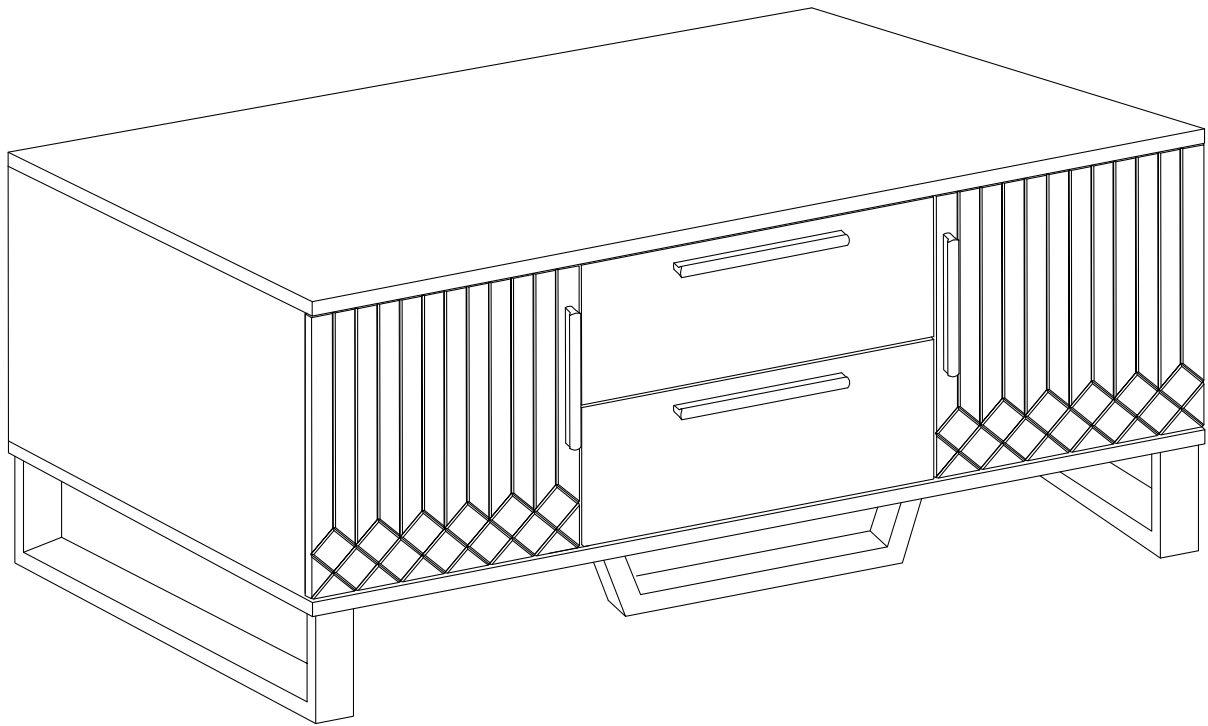

[DE]

Warnung: Lesen Sie die Anleitung vor dem Zusammenbau bitte vollständig durch. Überprüfen Sie, ob Sie alle auf den Seiten aufgeführten Komponenten und Werkzeuge haben.

Warnung: Legen Sie alle Teile auf eine ebene Fläche. Legen Sie eine weiche Decke oder Ähnliches darunter, um sie vor Kratzern oder Flecken zu schützen. Vermeiden Sie es, Komponenten über den Boden zu ziehen oder zu schieben.

Warnung: Überprüfen Sie regelmäßig alle Beschläge und Befestigungen, um sicherzustellen, dass sie sicher sind und um Unfälle zu vermeiden. Wenn Teile fehlen, kaputt, beschädigt oder abgenutzt sind, verwenden Sie das Produkt nicht weiter, bis es mit vom Hersteller autorisierten Teilen repariert wurde.

Warnung: Lassen Sie Kinder nicht auf die Möbel klettern, da dies zum Umkippen und zu schweren Verletzungen führen kann. Bauen Sie die Möbel außerhalb der Reichweite von Kindern zusammen.

Warnung: Stellen Sie die Möbel nicht in die Nähe von Feuerquellen oder heißen Gegenständen, um Brandgefahr zu vermeiden.

Warnung: Reinigen Sie die Möbel mit einem feuchten Tuch oder Alkohol. Verwenden Sie keine Reinigungsmittel mit ätzenden Chemikalien.

[EN]

Warning: Please read instructions fully before starting assembly. Check you have all the components and tools listed on pages.

Warning: Please place all parts on a flat surface. Place a soft blanket or similar underneath to protect against scratches or stains. Avoid dragging or sliding components across the floor.

Warning: Regularly check all fittings and fastenings to ensure they are secure and to prevent accidents. If any parts are missing, broken, damaged, or worn, discontinue use of the product until repairs have been made using factory authorized parts.

Warning: Do not allow children to climb on the furniture as this may result in tipping and serious personal injury. Assemble the furniture away from the reach of children.

Warning: Do not place furniture close to fire sources or high-temperature objects to avoid the risk of fire.

Warning: Clean furniture with a damp cloth or alcohol, avoid using cleaning agents containing corrosive chemicals.

[FR]

Avertissement : Veuillez lire entièrement les instructions avant de commencer l'assemblage. Vérifiez que vous disposez de tous les composants et outils répertoriés sur les pages.

Avertissement : Veuillez placer toutes les pièces sur une surface plane. Placez une couverture douce ou similaire en dessous pour les protéger des rayures ou des taches. Évitez de faire glisser les composants sur le sol.

Avertissement : Vérifiez régulièrement tous les raccords et fixations pour vous assurer qu'ils sont bien fixés et pour éviter les accidents. Si des pièces manquent, sont cassées, endommagées ou usées, cessez d'utiliser le produit jusqu'à ce que des réparations aient été effectuées à l'aide de pièces autorisées par l'usine.

Avertissement : Ne laissez pas les enfants grimper sur les meubles car cela pourrait entraîner un basculement et des blessures graves. Assemblez les meubles hors de portée des enfants.

Avertissement : Ne placez pas les meubles à proximité de sources de feu ou d'objets à haute température pour éviter tout risque d'incendie.

Avertissement : Nettoyez les meubles avec un chiffon humide ou de l'alcool, évitez d'utiliser des produits de nettoyage contenant des produits chimiques corrosifs.



[IT]

Attenzione: leggere attentamente le istruzioni prima di iniziare il montaggio. Verificare di avere tutti i componenti e gli strumenti elencati nelle pagine.

Attenzione: posizionare tutte le parti su una superficie piana. Posizionare una coperta morbida o simile sotto per proteggere da graffi o macchie. Evitare di trascinare o far scivolare i componenti sul pavimento.

Attenzione: controllare regolarmente tutti i raccordi e i dispositivi di fissaggio per assicurarsi che siano sicuri e per prevenire incidenti. Se alcune parti sono mancanti, rotte, danneggiate o usurate, interrompere l'uso del prodotto fino a quando non siano state eseguite le riparazioni utilizzando parti autorizzate dalla fabbrica.

Attenzione: non consentire ai bambini di arrampicarsi sui mobili poiché ciò potrebbe causare ribaltamenti e gravi lesioni personali. Montare i mobili lontano dalla portata dei bambini.

Attenzione: non posizionare i mobili vicino a fonti di fuoco o oggetti ad alta temperatura per evitare il rischio di incendio.

Attenzione: pulire i mobili con un panno umido o alcol, evitare di utilizzare detergenti contenenti sostanze chimiche corrosive.

[ES]

Advertencia: Lea las instrucciones completamente antes de comenzar el montaje. Compruebe que tiene todos los componentes y herramientas que se enumeran en las páginas.

Advertencia: Coloque todas las piezas sobre una superficie plana. Coloque una manta suave o algo similar debajo para protegerlas de rayones o manchas. Evite arrastrar o deslizar los componentes por el piso.

Advertencia: Verifique regularmente todos los accesorios y fijaciones para asegurarse de que estén seguros y evitar accidentes. Si falta alguna pieza, está rota, dañada o desgastada, deje de usar el producto hasta que se hayan realizado las reparaciones con piezas autorizadas de fábrica.

Advertencia: No permita que los niños se suban a los muebles, ya que esto puede provocar que se vuelquen y lesiones personales graves. Monte los muebles fuera del alcance de los niños.

Advertencia: No coloque los muebles cerca de fuentes de fuego u objetos de alta temperatura para evitar el riesgo de incendio.

Advertencia: Limpie los muebles con un paño húmedo o alcohol, evite usar agentes de limpieza que contengan químicos corrosivos.

| | |
|---|--|
| Importeur | Decobus Handel GmbH |
| Adresse | Innungsstraße 9, 21244 Buchholz, Deutschland |
| URL | https://www.decobusgroup.de |
| Hersteller | Xiamen Tanxing Import & Export Co.LTD |
| Adresse | Xiamen High-tech Zone,Fujian Province,China |
| Email/URL | tanxingfurniture@163.com |
|  | Decobus Handel GmbH Innungsstraße 9, 21244 Buchholz, Deutschland https://www.decobusgroup.de |

- **Wichtig** - Bitte lesen Sie diese Anleitung vollständig durch, bevor Sie mit der Montage beginnen.
- Wenn Sie Fragen zu diesem Produkt haben, wenden Sie sich bitte rechtzeitig an Ihren Lieferanten.
- Prüfen Sie, ob alle auf den Seiten **3** und **4** aufgeführten Komponenten und Werkzeuge vorhanden sind.
- Entfernen Sie alle Beschlüge aus den Plastikbeuteln und trennen Sie sie in ihre Gruppen.
- Kinder und Tiere vom Arbeitsbereich fernhalten, Kleinteile können beim Verschlucken ersticken.
- Teile der Montage werden mit **2 Personen** einfacher.
- Stellen Sie sicher, dass Sie genügend Platz haben, um die Teile anzuordnen, bevor Sie beginnen.
- Stellen Sie sich nicht auf das Produkt und belasten Sie es nicht, da dies zu Schäden führen kann.
- Montieren Sie den Artikel so nah wie möglich an seiner endgültigen Position (im selben Raum).
- Montieren Sie das Gerät auf einer weichen, ebenen Oberfläche, um eine Beschädigung des Geräts oder Ihres Bodens zu vermeiden (verwenden Sie den geöffneten Karton des Geräts).
- **Pflege und Wartung**
 - Nur mit einem feuchten Tuch und mildem Reinigungsmittel reinigen, keine Bleich- oder Scheuermittel verwenden.
Wenn Sie Fragen zu diesem Produkt haben, wenden Sie sich bitte rechtzeitig an Ihren Lieferanten.
 - Prüfen Sie von Zeit zu Zeit, ob die Schrauben am Produkt locker sind.

Notiz

- Bei Bedarf kann die nächste Seite ausgeschnitten und während der gesamten Montage als Referenz verwendet werden.
- Bewahren Sie diese Seite mit diesen Anweisungen zum späteren Nachschlagen auf.

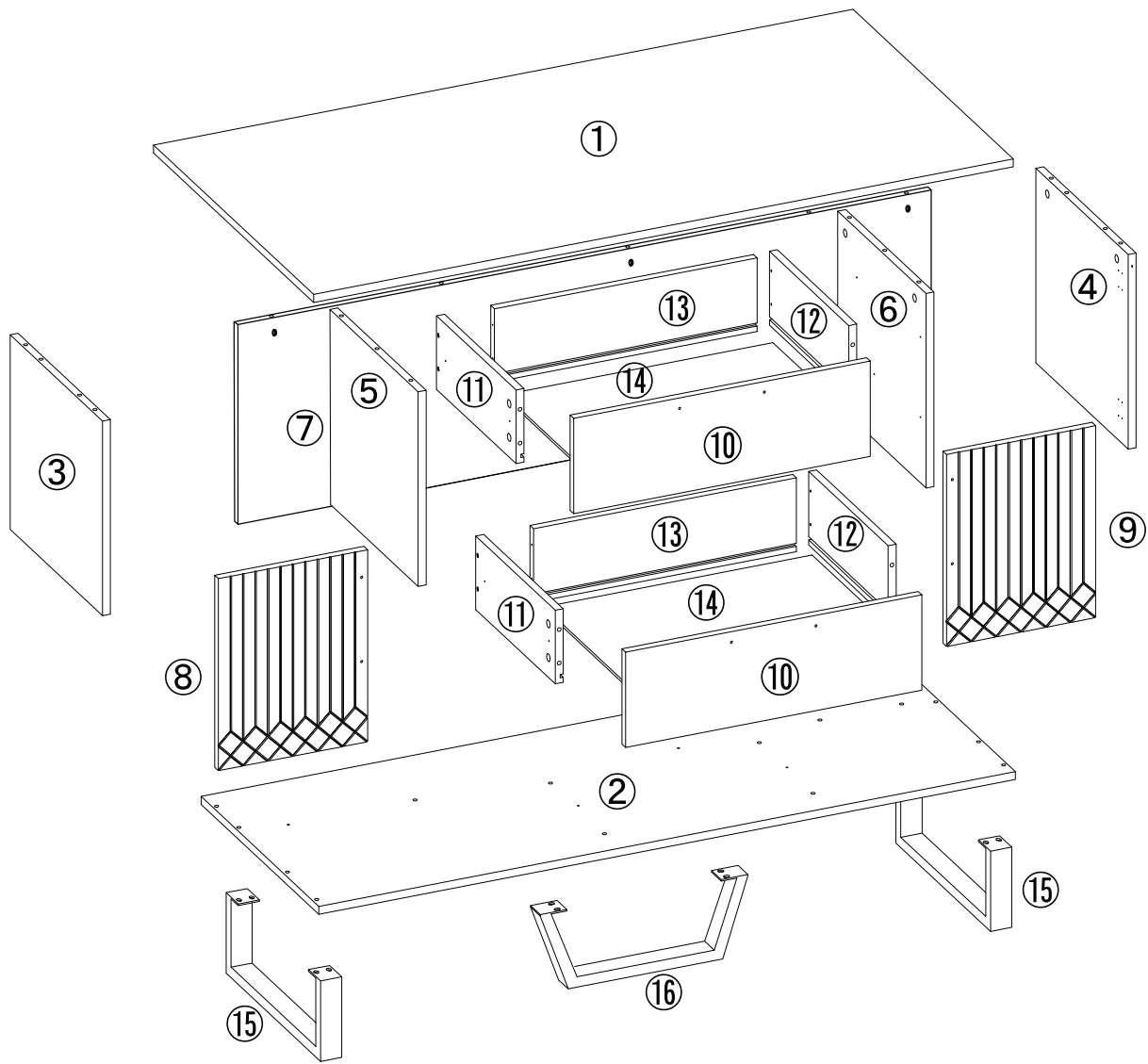

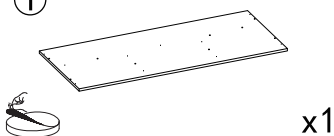
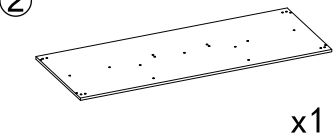
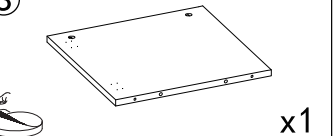
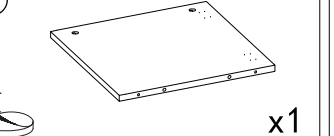
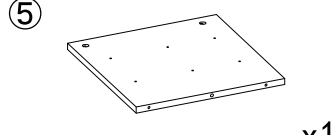
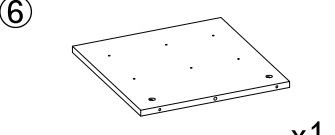
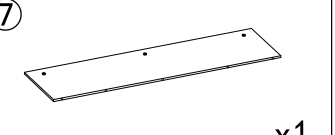
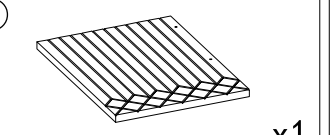
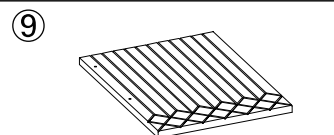
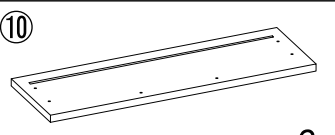
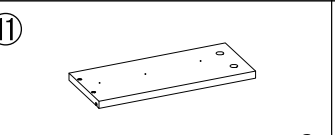
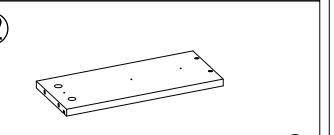
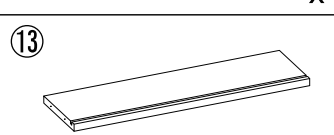
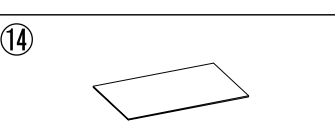
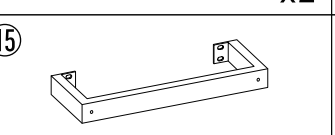
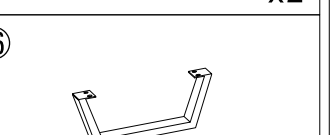
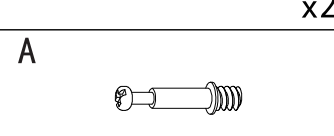
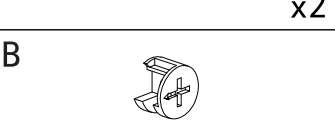
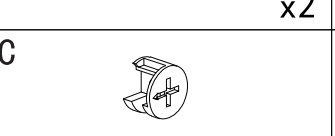
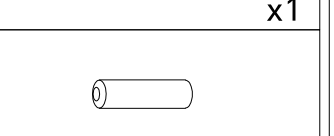
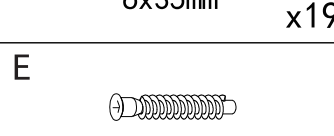
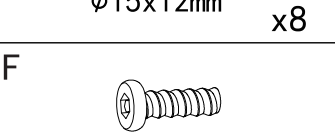
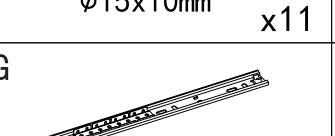
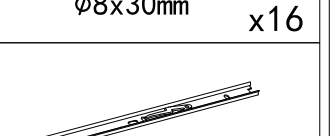
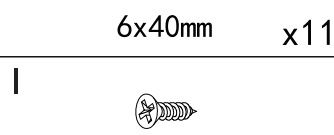
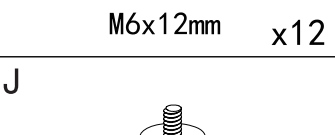
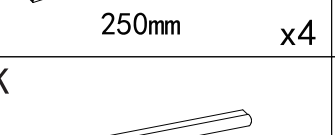
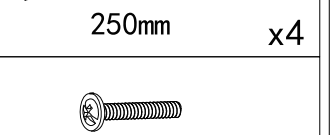
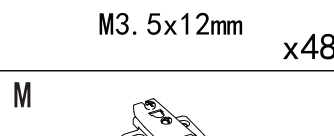
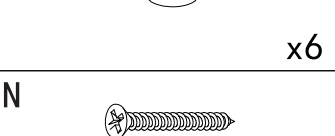
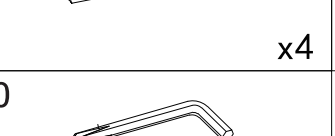
| | | | |
|---|---|--|---|
| ①  x1 | ②  x1 | ③  x1 | ④  x1 |
| ⑤  x1 | ⑥  x1 | ⑦  x1 | ⑧  x1 |
| ⑨  x1 | ⑩  x2 | ⑪  x2 | ⑫  x2 |
| ⑬  x2 | ⑭  x2 | ⑮  x2 | ⑯  x1 |
| A  6x35mm x19 | B  ø15x12mm x8 | C  ø15x10mm x11 | D  ø8x30mm x16 |
| E  6x40mm x11 | F  M6x12mm x12 | G  250mm x4 | H  250mm x4 |
| I  M3.5x12mm x48 | J  x6 | K  x4 | L  M4x18mm x8 |
| M  x4 | N  M4x30mm x8 | O  M4 x1 | |

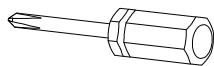

philis head screwdrier rewiured of assembly
Felix *bolzen. An und aus
Es ist notwendig für die montage
(Not inc luda)
(Ist das ein luda)



hammer
hammer
(Not inc luda)
(Ist das ein luda)



electric drill
Bohrer
(Not inc luda)
(Ist das ein luda)

STEP 1

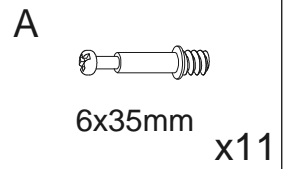
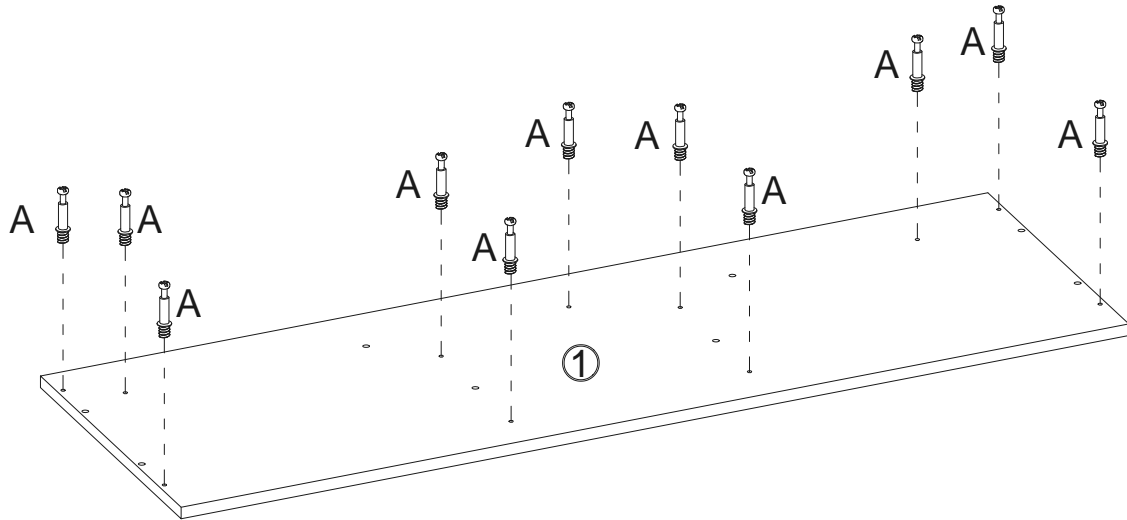

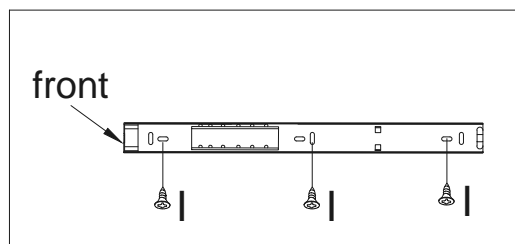
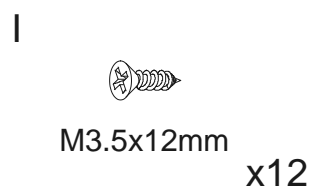
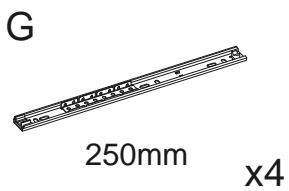
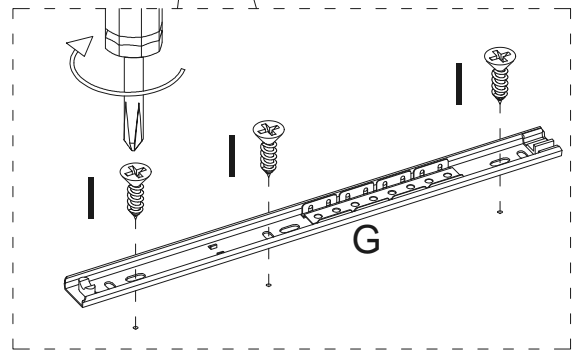
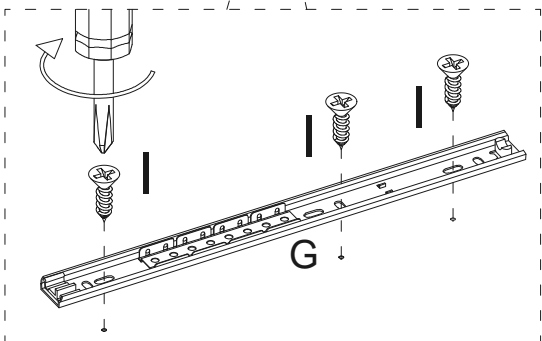
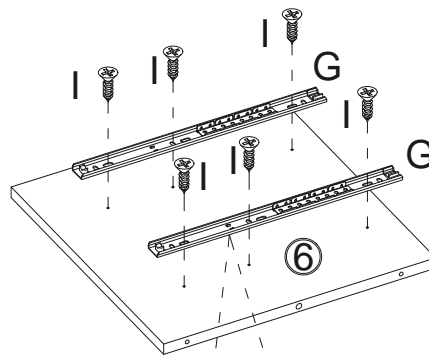
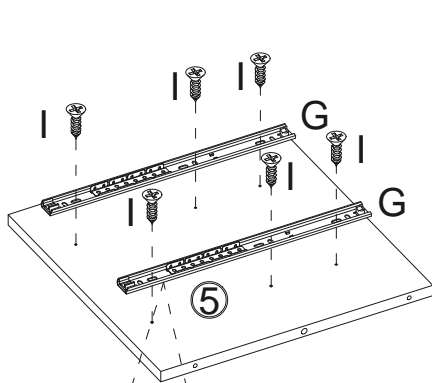

STEP 2



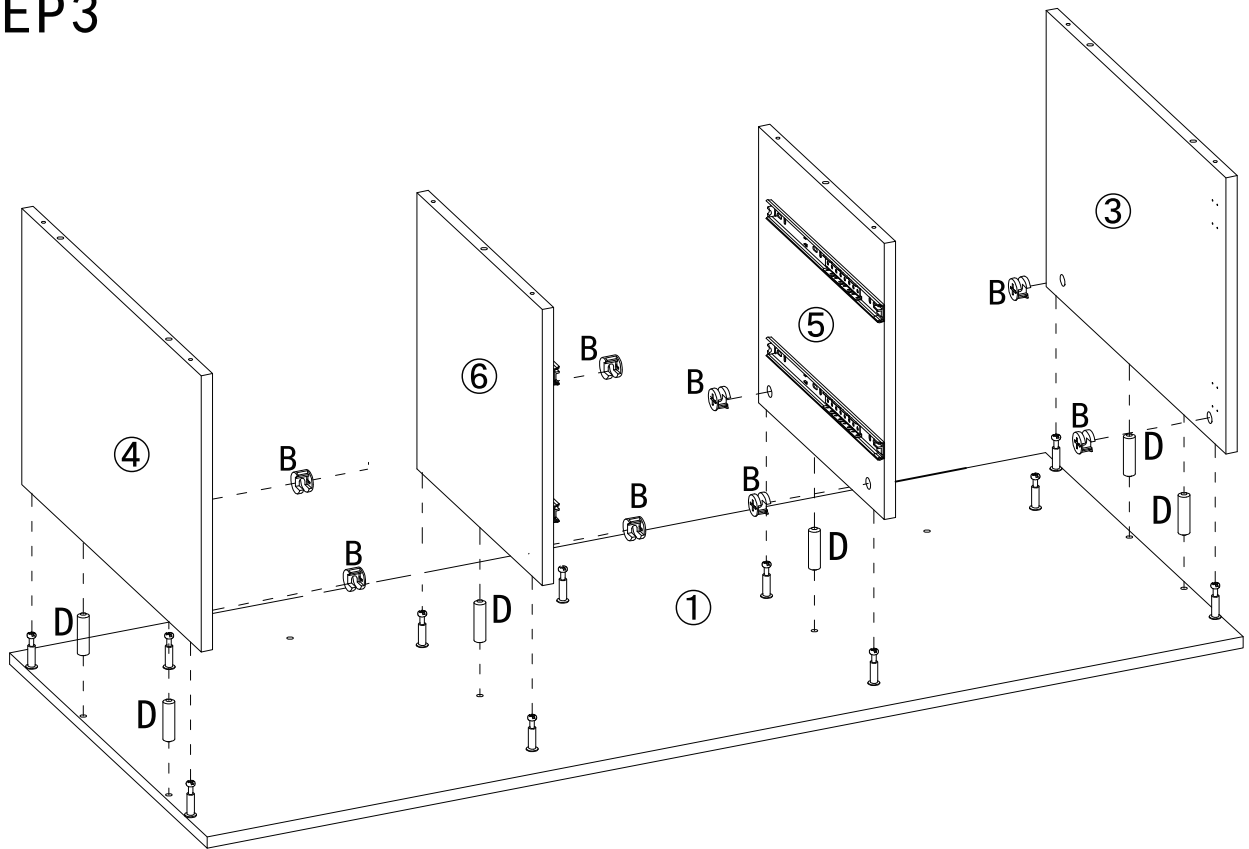

STEP 3



| | |
|--|---|
| <p>B</p>  <p>φ15x12mm x8</p> | <p>D</p>  <p>φ8x30mm x6</p> |
|--|---|

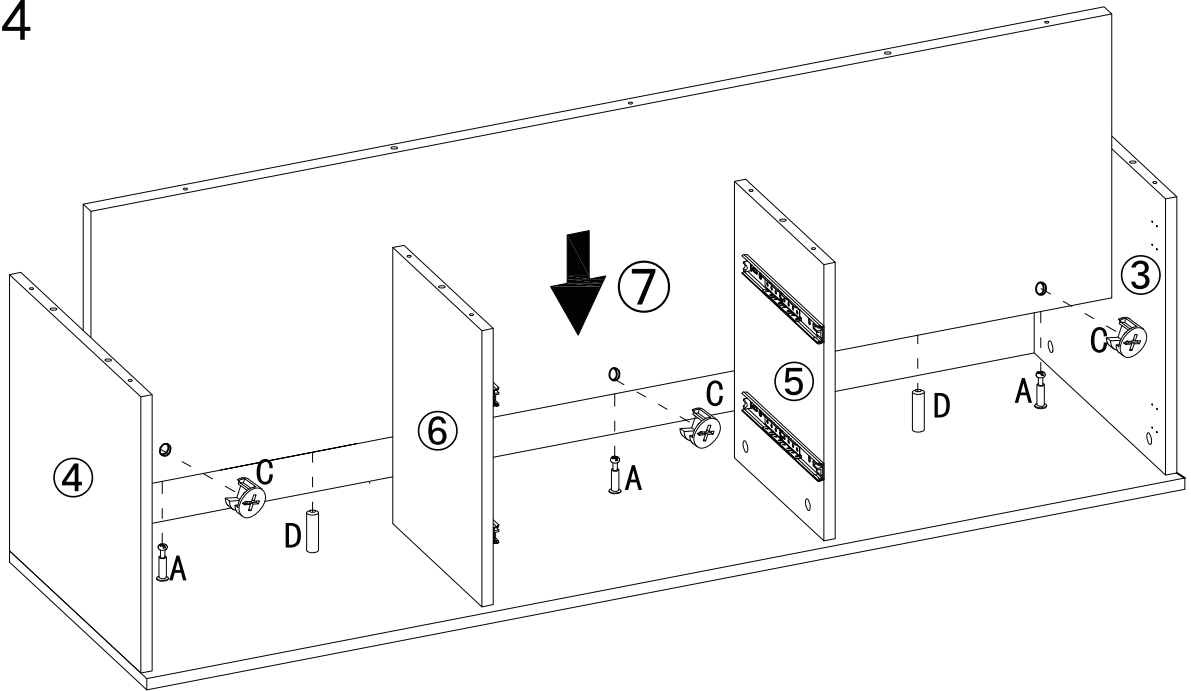

STEP 4

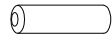

| | |
|--|---|
| <p>C</p>  <p>φ15x10mm x3</p> | <p>D</p>  <p>φ8x30mm x2</p> |
|--|---|

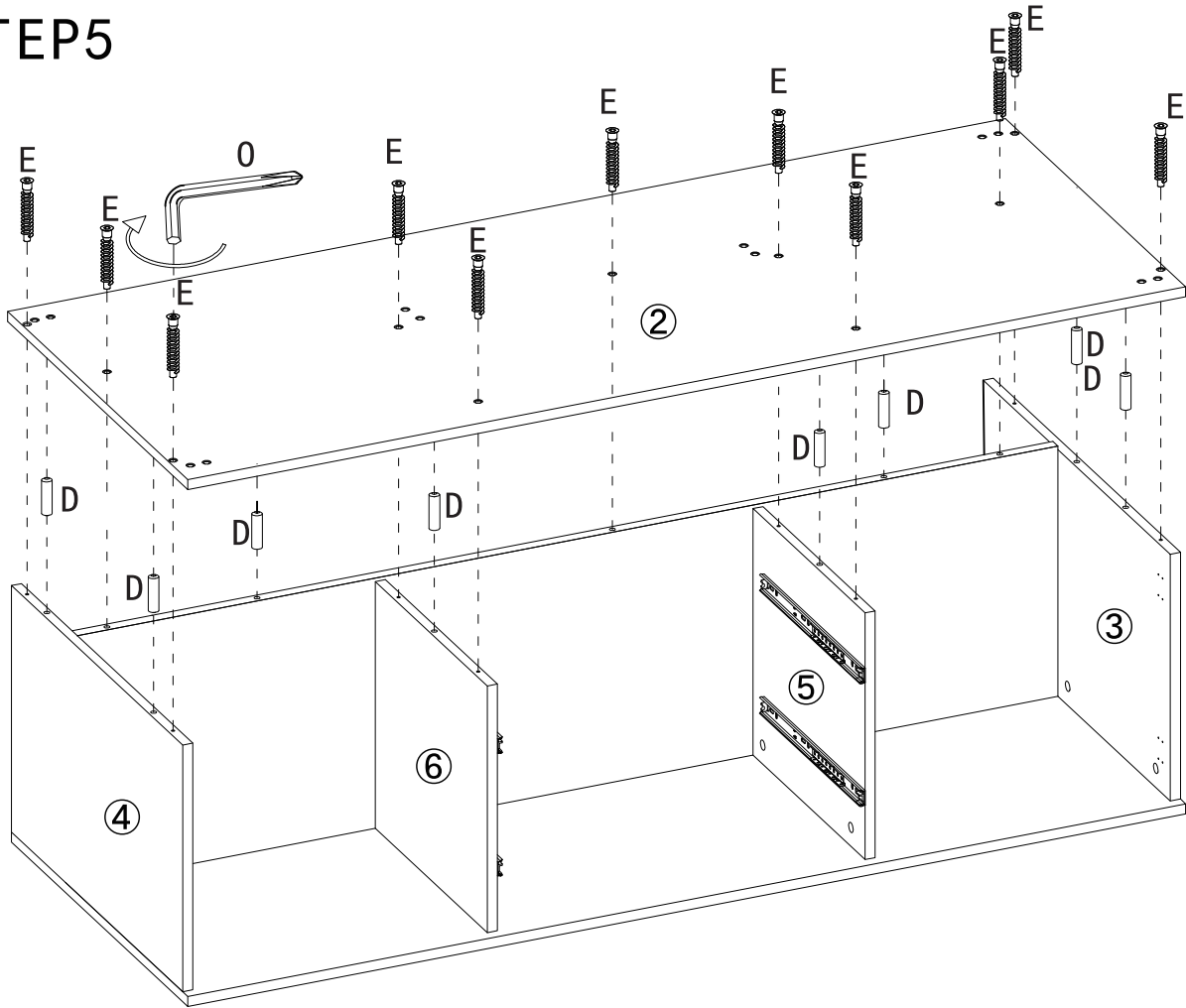
STEP 5

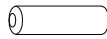
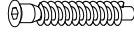

| | | |
|---|---|--|
| <p>D</p>  <p>ø8x30mm x8</p> | <p>E</p>  <p>6x40mm x11</p> | <p>O</p>  <p>M4 x1</p> |
|---|---|--|

STEP 6

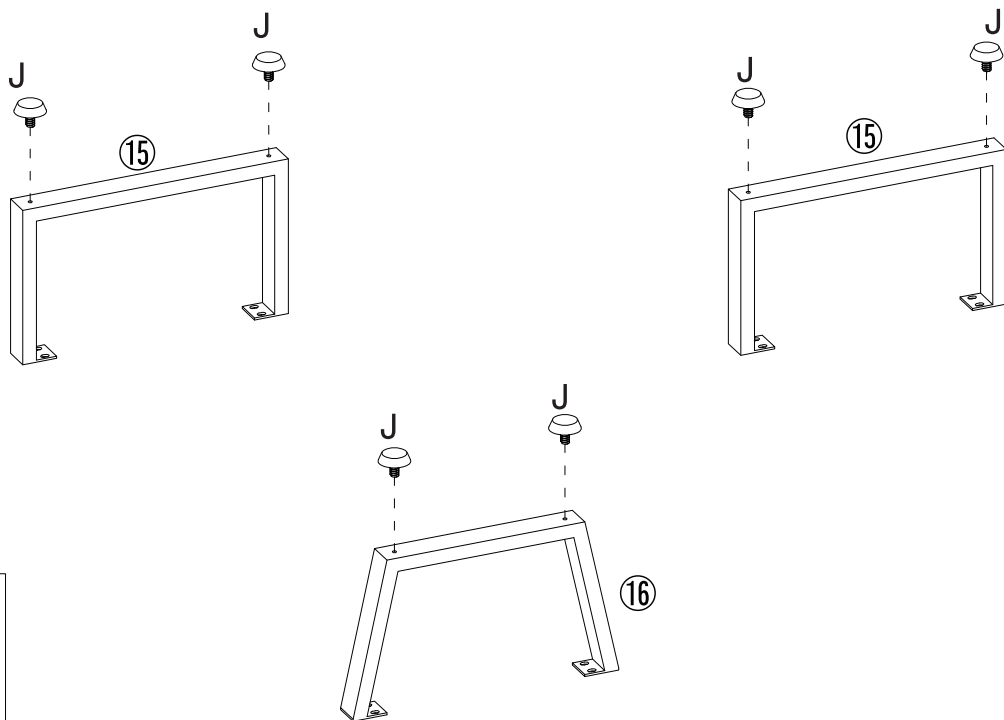

| |
|---|
| <p>J</p>  <p>x6</p> |
|---|

STEP 7

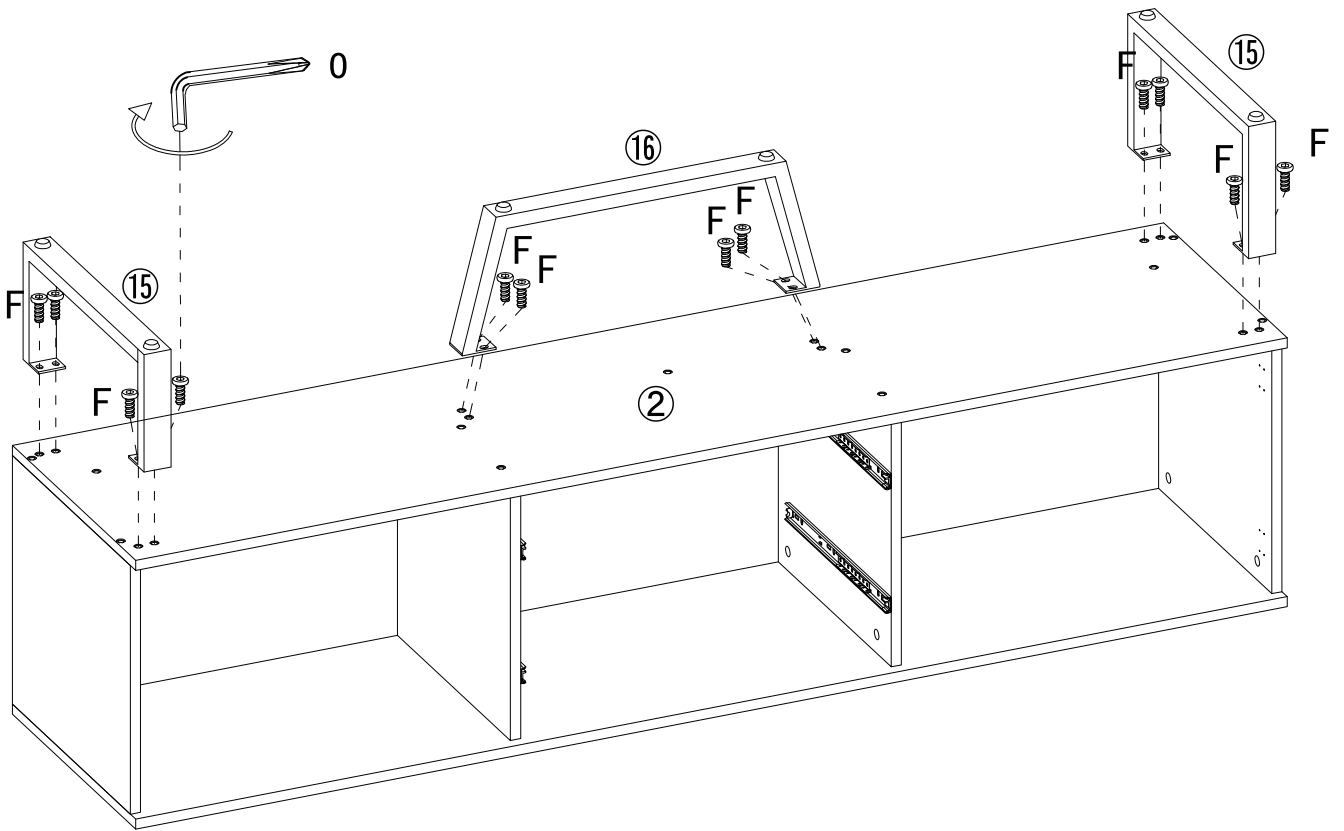

F

M6x12mm x12

0

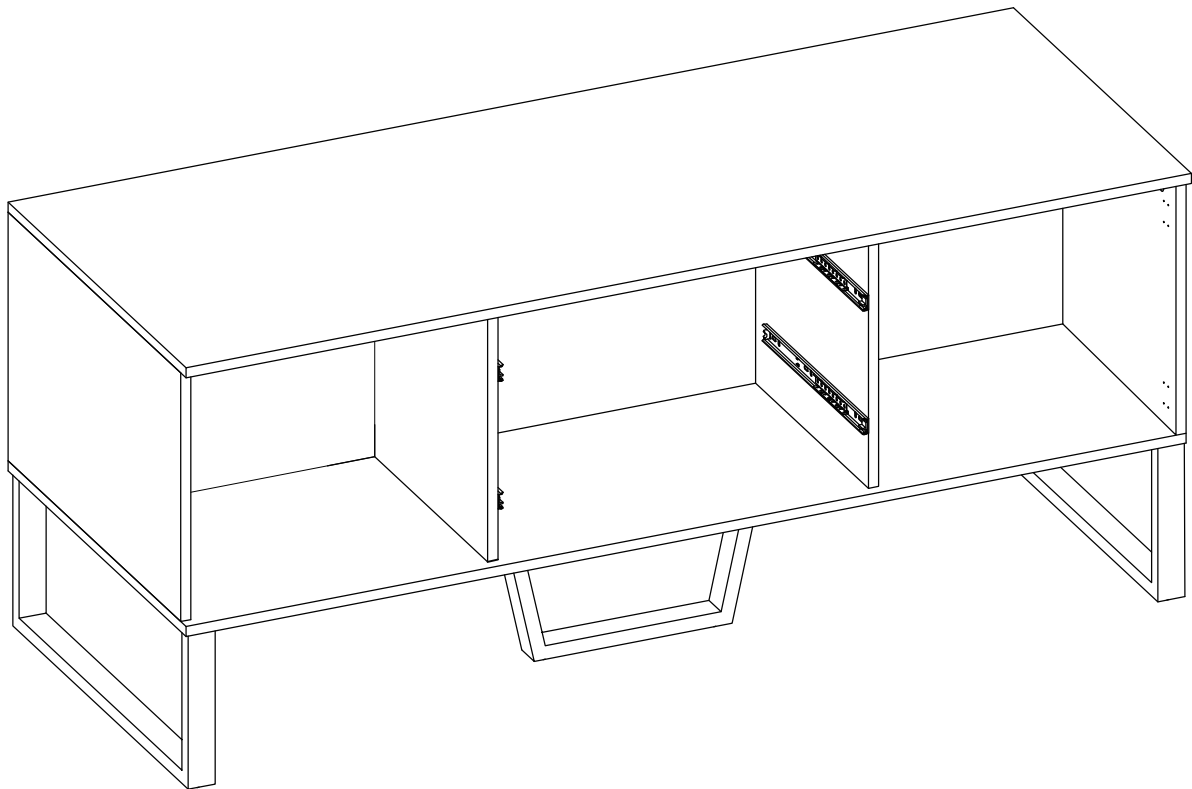
M4 x1

STEP 8

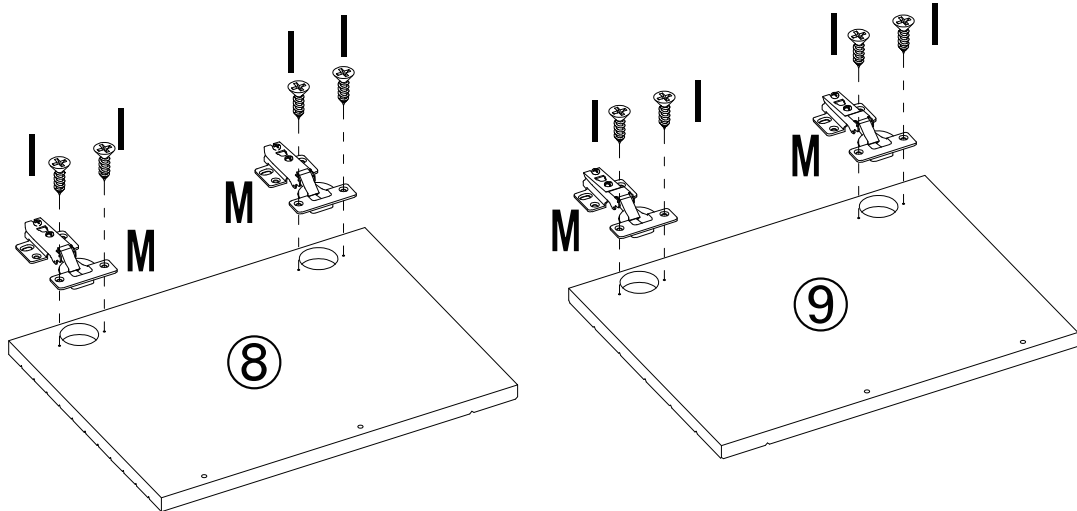

STEP 9

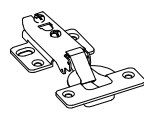

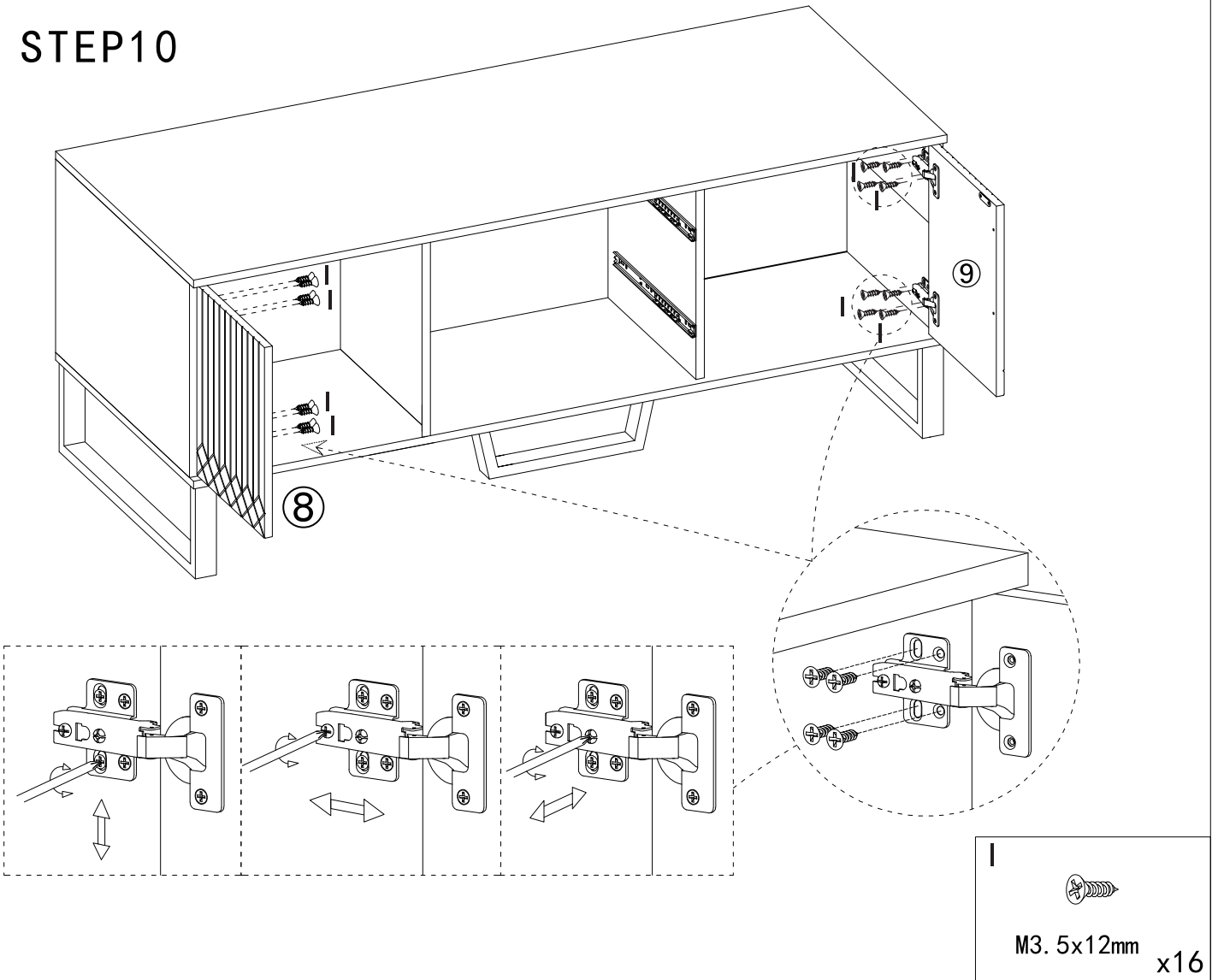

| | |
|---|---|
| I  M3. 5x12mm x8 | M  x4 |
|---|---|

STEP10

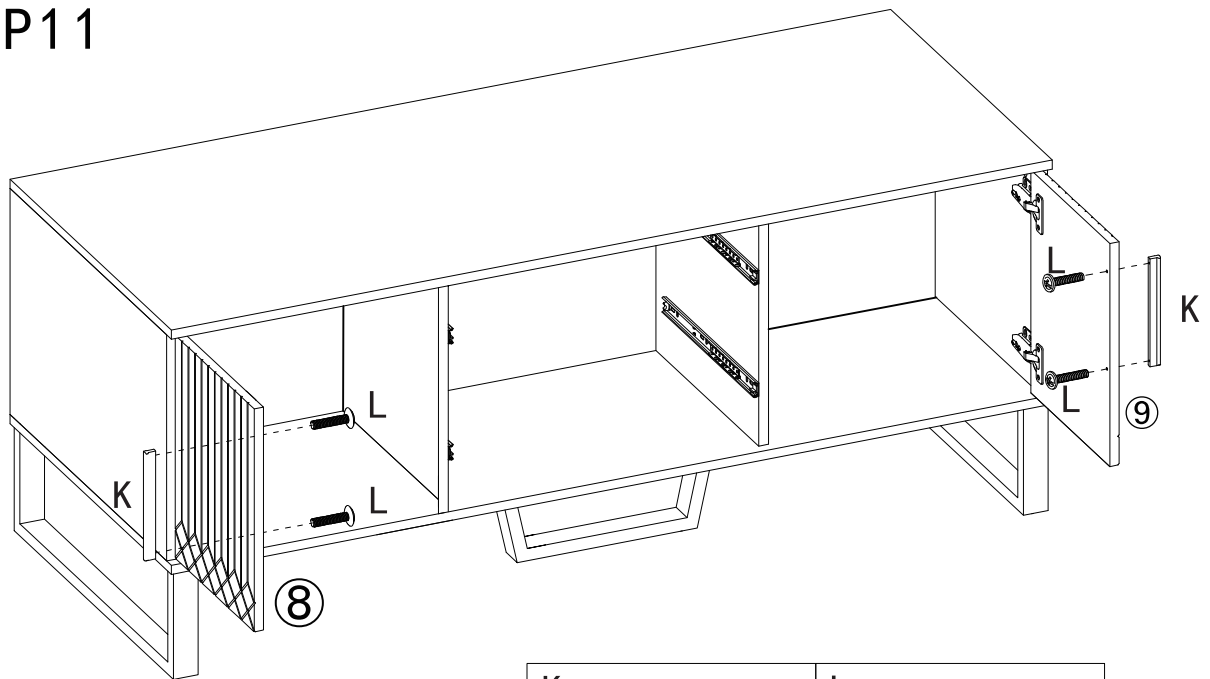

STEP11

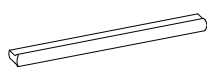

| | |
|---|--|
| <p>K</p>  <p>x2</p> | <p>L</p>  <p>M4x18mm</p> <p>x4</p> |
|---|--|

STEP 12

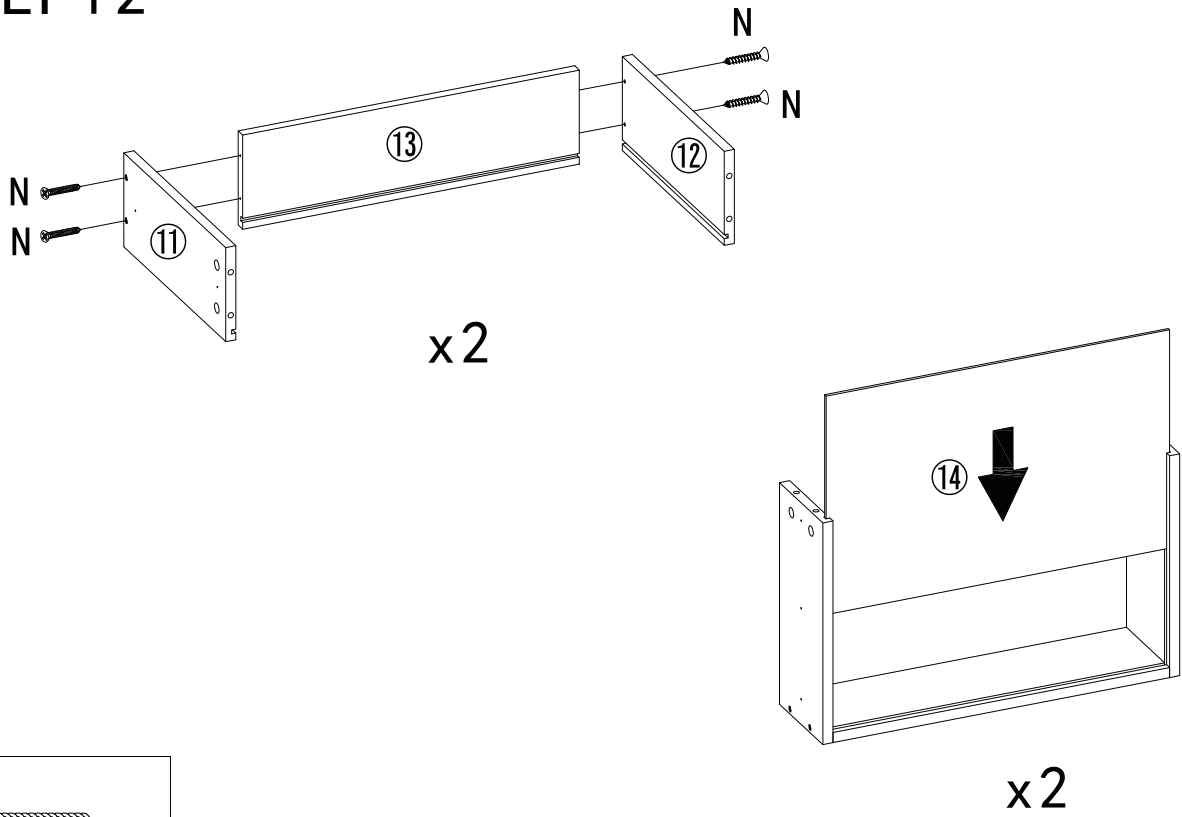



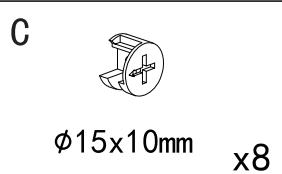
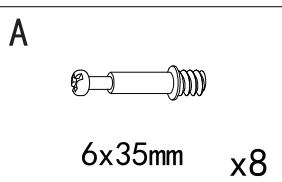
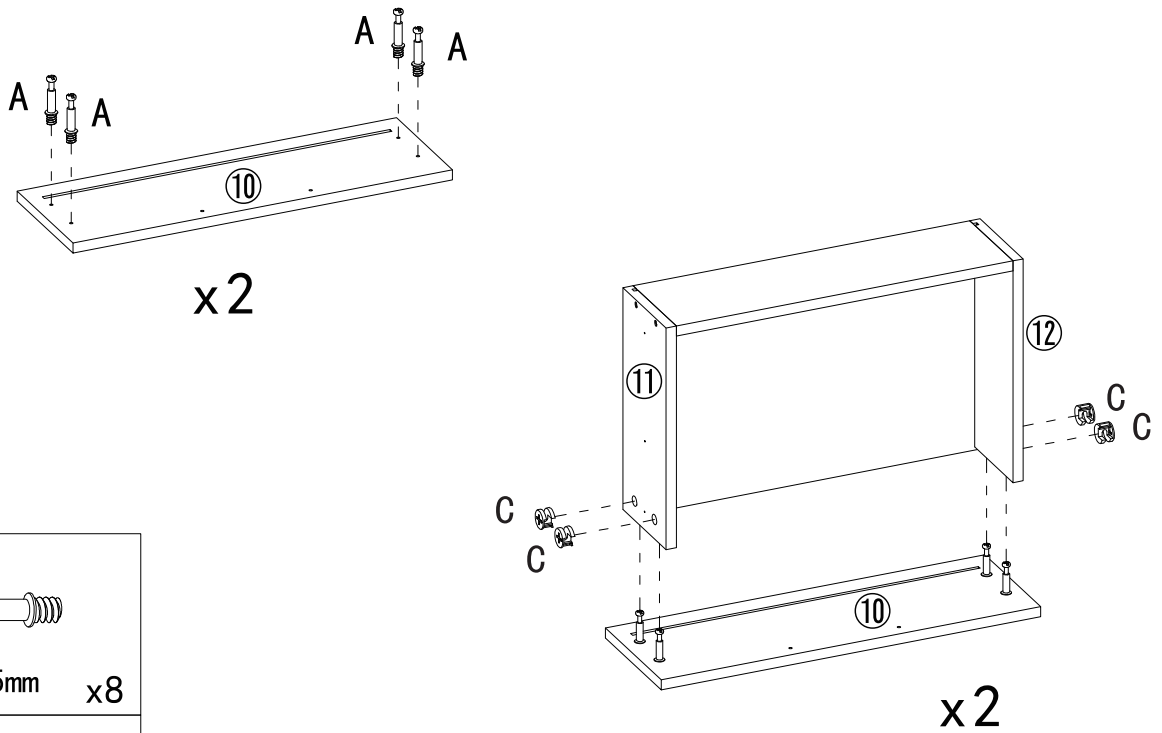

STEP 13

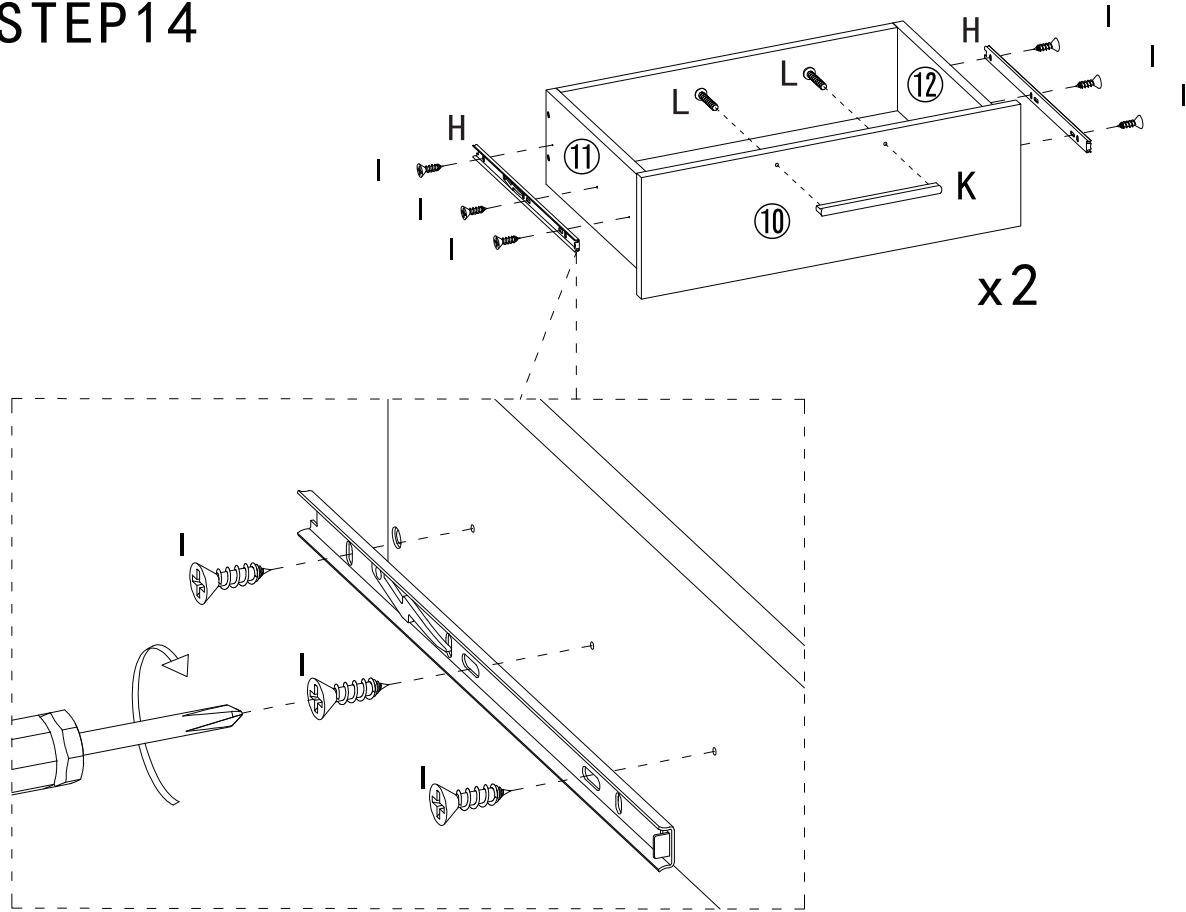

STEP 14



| | | | |
|---|---|---|--|
| K  x2 | L  M4x18mm x4 | H  250mm x4 | I  M3.5x12mm x12 |
|---|---|---|--|

STEP 15

