

# MONTAGEANLEITUNG

## WF308220/ WF308221

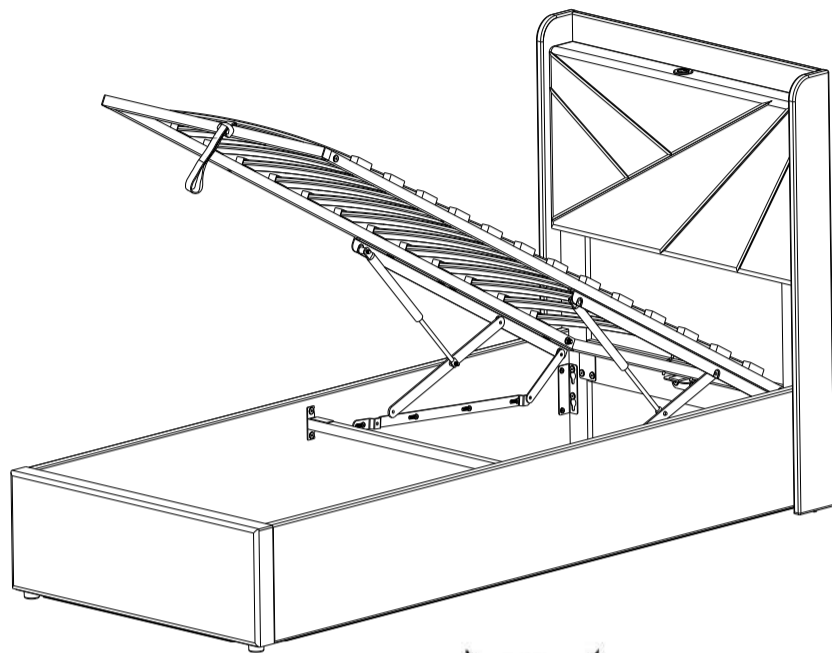

Please check that you have all the parts listed before you start assembling, if you do find that something is missing, do not continue assembly, please contact us immediately.

NOTE: Please do not completely tighten all the hardware until the entire assembly is complete!

Bitte überprüfen Sie, ob alle Teile mitgeliefert sind, bevor Sie mit der Montage beginnen. Wenn Sie festlegen, dass etwas fehlt, setzen Sie die Montage nicht fort. Bitte kontaktieren Sie uns sofort.

Achtung: Bitte ziehen Sie nicht alle Schrauben fest, bevor die Montage abgeschlossen ist!

**D** Gebrauchsanweisung

**NL** Gebruiksrichtlijnen

**IT** Istruzioni per l'uso

**CZ** Pokyny k použití

**HU** Használati útmutató

**PT** Instruções de utilização

**SK** Pokyny k použitiu

**GB** Instructions for use

**FR** Instructions d'utilisation

**PL** Instrukcja obsługi

**ES** Instrucciones de empleo

**RO** Instrucțiuni de folosire

**RU** Инструкция по монтажу

**TR** Kullanım talimatları

This set will be shipped by 2 boxes and they may arrive on different days. If both packages arrived but parts missing, please contact customer service.

Dieses Set ist in 2 Boxen enthalten. Wenn Sie keine vollen 2 Boxen erhalten, wenden Sie sich bitte an unseren Kundenservice

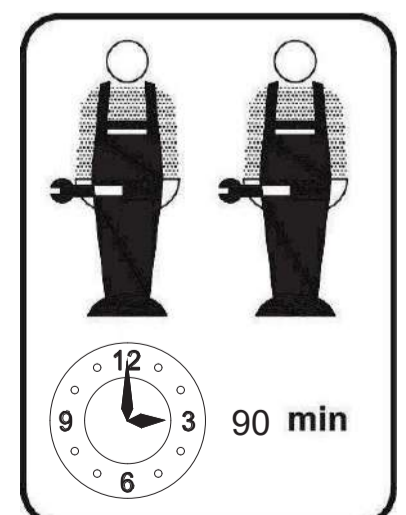

**FR - Notice de montage / EN - Assembly instructions / PT - Instruções de montagem /  
ES - Prospecto de montaje / DE - Montageanleitung / IT - Istruzioni di montaggio /  
NL - Montagehandleiding**

**FR - IMPORTANT! CONSERVER POUR CONSULTATION ULTERIEURE: LIRE ATTENTIVEMENT**

- A monter par un adulte. Un adulte doit vérifier le bon assemblage avant l'emploi
- ATTENTION! tenir les vis et petits éléments et sachets hors de portée des enfants
- Bien identifier les éléments avant de commencer le montage
- Ne pas utiliser votre article lorsque l'un de ses éléments est cassé ou manquant
- En cas de problème contactez notre service après-vente
- Toujours suivre les instructions du fabricant
- Entretien: nettoyer avec un chiffon doux et sec. En cas de taches plus grosses, frottez soigneusement avec une éponge légèrement humide et non abrasive
- Ne pas sauter sur le lit

**EN - IMPORTANT! KEEP FOR FUTURE REFERENCE: READ CAREFULLY**

- To be assembled by an adult. Assembly must be checked by an adult before use
- WARNING! keep all screws, small parts and plastic bags out of the reach of children
- Properly identify all parts before assembling
- Never use your item if any of its parts are broken or missing
- Should any problems arise, please contact our After Sales Service
- Manufacturer's instructions shall be followed at all times
- Care: clean with a soft, dry cloth. In case of larger stains, carefully rub with a slightly damp, non-abrasive sponge
- Do not jump on the bed

**PT - IMPORTANTE! GARDE PARA CONSULTA POSTERIOR: LER ESTAS INSTRUÇÕES CUIDADOSAMENTE**

- A ser montado por um adulto. Um adulto deve verificar a boa montagem antes da utilização
- Atenção! mantenha os parafusos, acessórios pequenos e saco de plástico fora do alcance das crianças
- Identifique bem os acessórios antes de começar a montagem
- Não utilizar o artigo se um dos elementos está em falta ou danificado
- Para qualquer esclarecimento, contacte os nossos serviços através do telefone
- As instruções do fabricante devem ser sempre cumpridas
- Manutenção: limpe com um pano macio e seco. Em caso de manchas maiores, esfregue cuidadosamente com uma esponja ligeiramente húmida e não abrasiva
- Não salte na cama

**ES - IMPORTANTE! CONSERVAR PARA FUTURAS CONSULTAS: LEER DETENIDAMENTE**

- A montar por un adulto. Un adulto debe comprobar el buen montaje antes de la utilización
- ¡ADVERTENCIA! mantener los tornillos, los pequeños elementos y bolsitas fuera del alcance de los niños
- Identificar debidamente los elementos antes de empezar el montaje
- No utilizar este artículo si uno de los elementos falta o esta roto
- Si tiene problemas, contactar nuestro servicio postventa
- Deben seguirse siempre las instrucciones del fabricante Cuidados: limpiar con un paño suave y seco. En caso de manchas grandes, frotar con cuidado utilizando una esponja húmeda no abrasiva
- No saltar sobre la cama

**DE - WICHTIG! FÜR SPÄTERE BEZUGNAHME AUFBEWAHREN: SORGFÄLTIG LESEN**

- Von einem Erwachsenen zu montieren. Die korrekte Montage muss vor Gebrauch von einem Erwachsenen geprüft werden
- Achtung! die Schrauben und kleinen Teile ausserhalb der Reichweite von Kindern lagern
- Vor Montagebeginn alle Teile identifizieren
- Ihren Artikel nicht benutzen, wenn eines seiner Bestandteile beschädigt ist oder fehlt
- Im Problemfall Ihren Kundendienst anrufen
- Stets die Herstelleranweisungen beachten
- Wartung: Mit einem weichen, trockenen Tuch reinigen. Bei größeren Flecken vorsichtig mit einem leicht feuchten, nicht scheuernden Schwamm abreiben
- Nicht auf dem Bett springen

**IT - IMPORTANTE! CONSERVARE QUESTE INFORMAZIONI PER ULTERIORI CONSULTAZIONI: LEGGI ATTENTAMENTE**

- Il montaggio deve essere eseguito da un adulto. Un adulto dovrà verificare il corretto montaggio prima dell'uso
- ATTENZIONE! tenere le viti ed i componenti di piccole dimensioni lontano dalla portata dei bambini
- Controllare i pezzi prima del montaggio
- L'articolo non deve essere utilizzato in caso di elementi mancanti o danneggiati
- In caso di necessità contattare il nostro servizio post-vendita
- Seguire sempre le istruzioni del costruttore
- Manutenzione: pulire con un panno morbido e asciutto. Per le macchine più grandi, strofinare accuratamente con una spugna leggermente umida e non abrasiva
- Non saltare sul letto



**NL - BELANGRIJK! BEWAAR VOOR LATERE RAADPLEGING: LEES AANDACHTIG**

- Moet door een volwassene worden gemonteerd. Voor gebruik moet een volwassene controleren dat het product goed in elkaar is gezet
- WAARSCHUWING! schroeven en kleine elementen en zakjes buiten bereik van kinderen houden
- De elementen goed identificeren alvorens met de montage te beginnen
- Uw artikel niet gebruiken wanneer een van de onderdelen kapot is of ontbreekt
- Neem bij problemen contact op met onze klantenservice
- Volg altijd de instructies van de fabrikant
- Onderhoud: maak schoon met een zachte en droge doek. In geval van grotere vlekken, veeg voorzichtig schoon met een licht bevochtigde en niet-schurende spons
- Niet springen op het bed

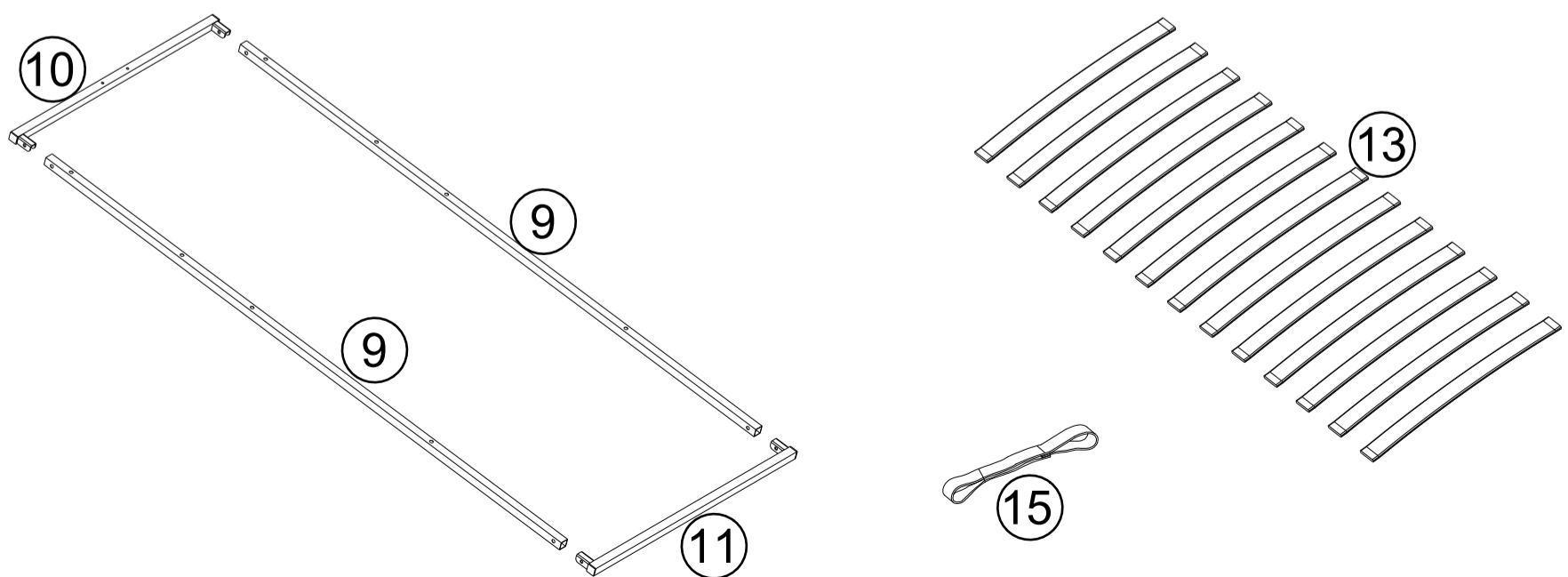
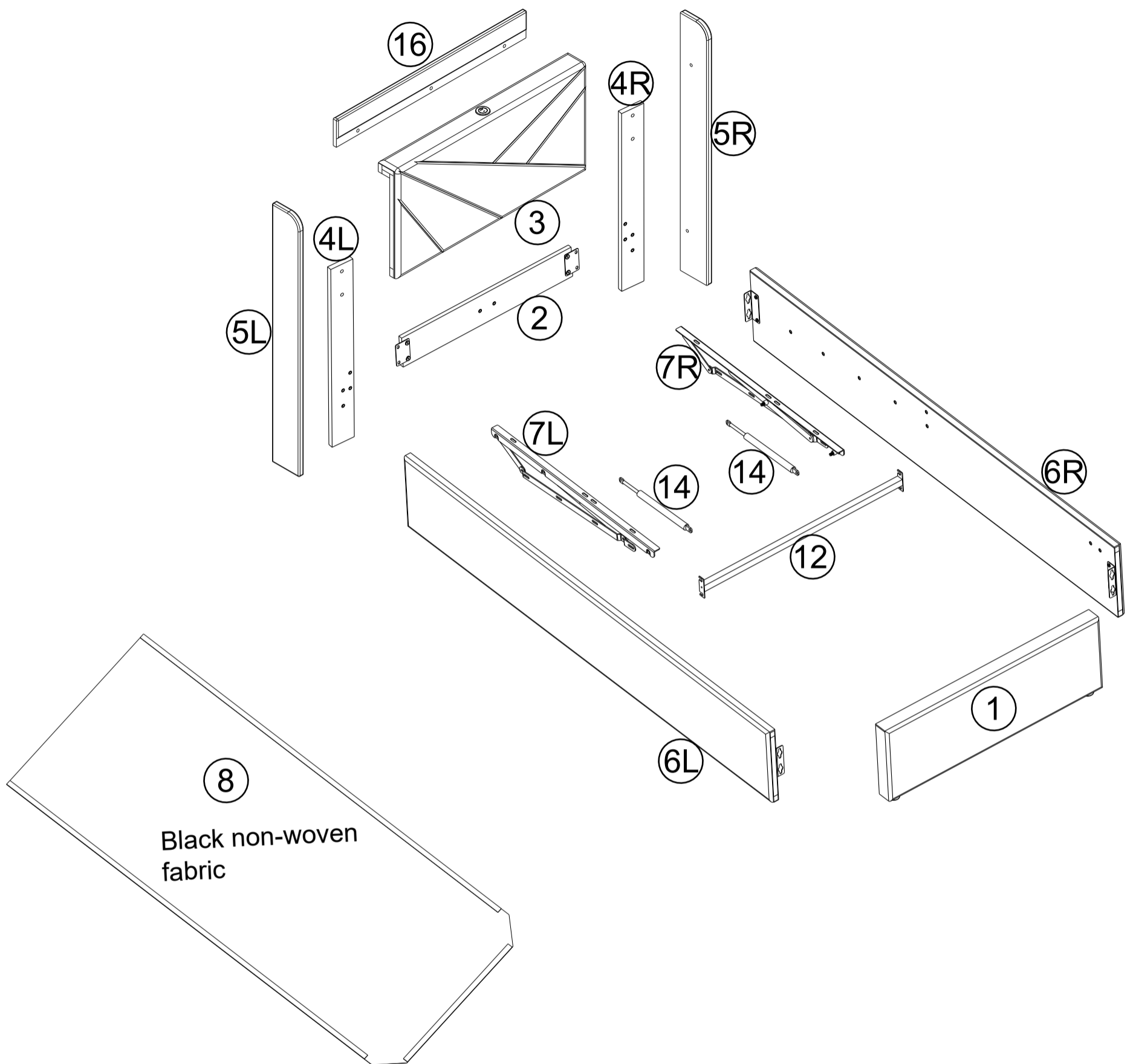
# Stückliste

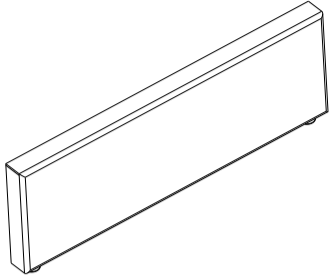
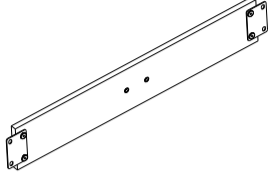
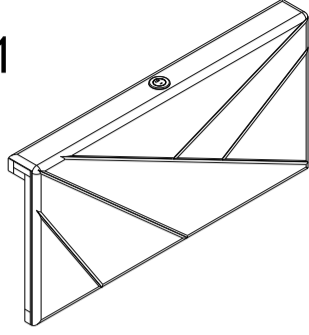
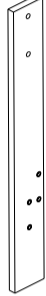

# Part List-Stückliste WF308220

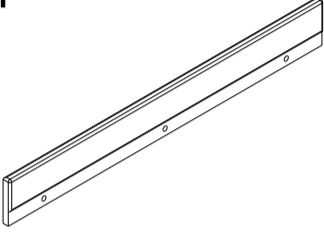
<p>① x1</p> 	<p>② x1</p> 	<p>③ x1</p> 
<p>④L x1</p> 	<p>④R x1</p> 	<p>⑬ x1</p> 



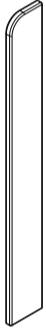
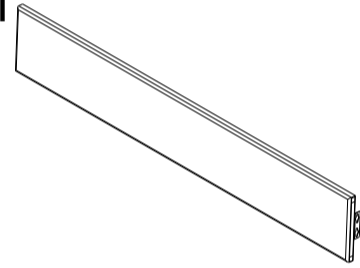
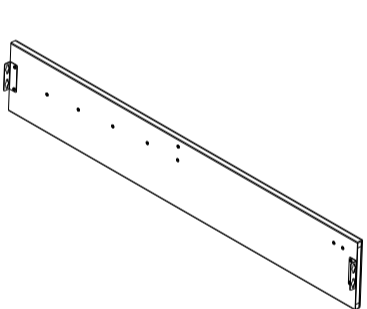
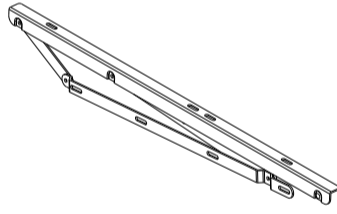
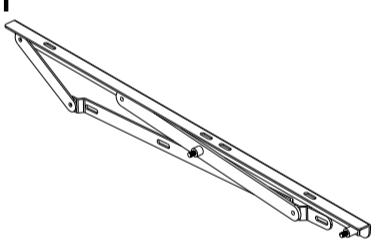
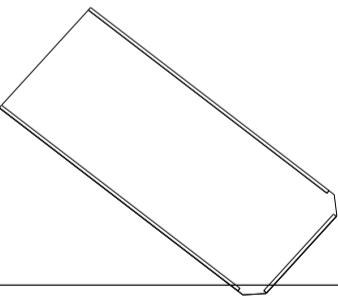
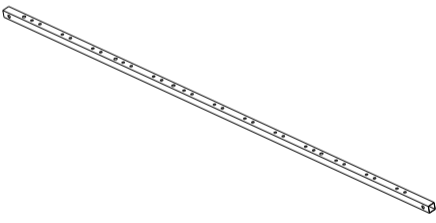
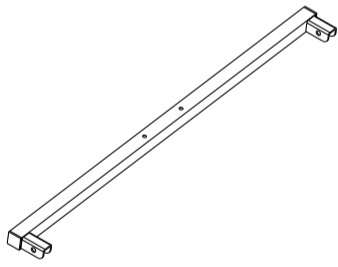
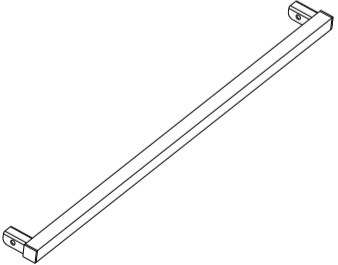
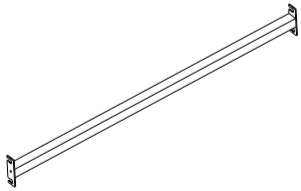
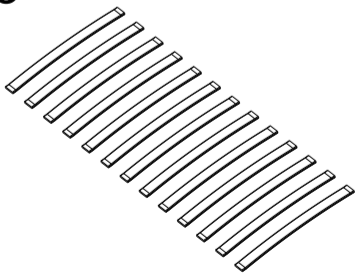
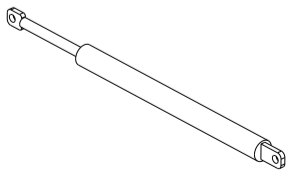
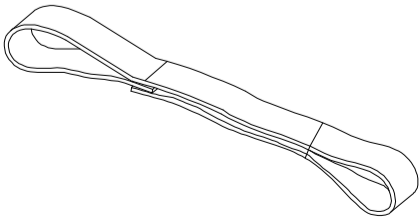

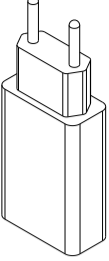

# Part List-Stückliste WF308221

<p>⑤L x1</p> 	<p>⑤R x1</p> 	<p>⑥L x1</p> 
<p>⑥R x1</p> 	<p>⑦L x1</p> 	<p>⑦R x1</p> 
<p>⑧ x1</p> 	<p>⑨ x2</p> 	<p>⑩ x1</p> 
<p>⑪ x1</p> 	<p>⑫ x1</p> 	<p>⑬ x13</p> 
<p>⑭ x2</p> 	<p>⑮ x1</p> 	

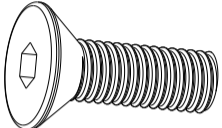
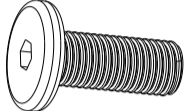
# Hardware List- Hardware-Liste WF308220

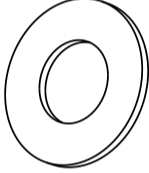
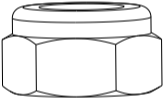
<p>Q x1</p> 		
---	--	--

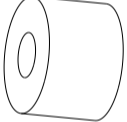
# Hardware List- Hardware-Liste WF308221

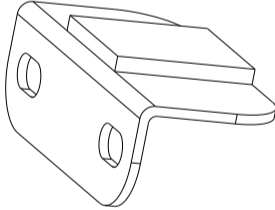
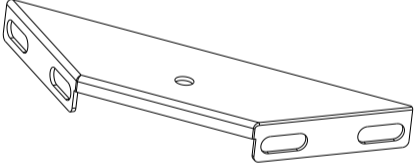
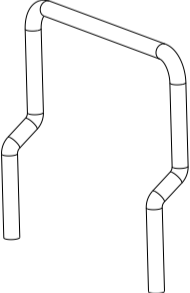
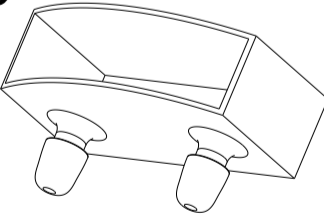
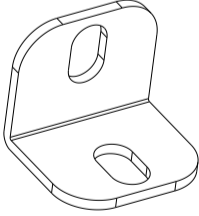
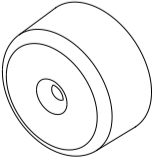
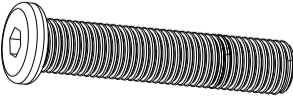
<p>A x1</p> 	<p>B x4</p>  <p>M8x18mm</p>	<p>C x32</p>  <p>M8x20mm</p>
<p>D x8</p>  <p>M8x30mm</p>	<p>E x14</p>  <p>M8x40mm</p>	<p>F x11</p> 
<p>G x14</p>  <p>M8</p>	<p>H x1</p> 	<p>J x8</p> 
<p>K x2</p>  <p>M4x40mm</p>	<p>L x2</p> 	<p>M x2</p> 
<p>N x1</p> 	<p>P x26</p> 	<p>R x4</p> 
<p>S x2</p> 	<p>T x3</p>  <p>M8x35mm</p>	

## **Delivery**

To reduce the chance of damage, this set will be shipped by 2 boxes and they may arrive on different days. If both packages arrived but parts missing, please contact customer service.

## **Important Information**

Please do not return the product directly without contacting customer service.

Please feel free to contact us with any inquiries or concerns you may have about the product.

Thanks for your understanding.

In the unlikely case where you believe to have identified a manufacturing fault, the product must be subject to the guarantee.

We will endeavour to organise replacements where required as quickly as possible, but customers should be aware of possible delays if third party suppliers need further instructions.

Most or all of the following are request to report issue to customer service: images /videos showing the defect, weight of product user(s), claimant name and address, order number, full description of complaint.

## **Lieferung**

Um das Risiko einer Beschädigung zu verringern, wird dieses Set in 2 Paketen verschickt, die an verschiedenen Tagen ankommen können. Wenn beide Pakete angekommen sind, aber Teile fehlen, kontaktieren Sie bitte den Kundendienst.

## **Wichtige Information**

Bitte senden Sie das Produkt nicht direkt zurück, ohne den Kundenservice zu kontaktieren. Bitte zögern Sie nicht, sich mit uns in Verbindung zu setzen, wenn Sie Fragen oder Bedenken bezüglich des Produkts haben.

Vielen Dank für Ihr Verständnis.

In dem unwahrscheinlichen Fall, dass Sie glauben, einen Herstellungsfehler festgestellt zu haben, muss das Produkt unter die Garantie fallen.

Wir werden uns bemühen, bei Bedarf so schnell wie möglich Ersatz zu organisieren, aber die Kunden sollten sich über mögliche Verzögerungen im Klaren sein, wenn Drittanbieter weitere Anweisungen benötigen.

Für die Meldung des Problems an den Kundendienst sind die meisten oder alle der folgenden Angaben erforderlich: Bilder/Videos, die den Fehler zeigen, Gewicht des/der Produktnutzer(s), Name und Adresse des Antragstellers, Bestellnummer, vollständige Beschreibung der Beschwerde.

1

A x 1	T x 3 M8 x 35mm	F x 3	
-------	--------------------	-------	--

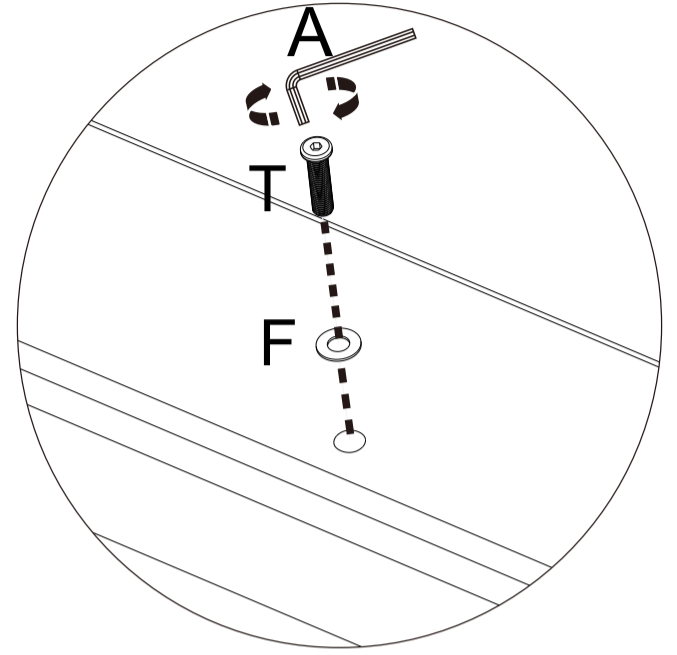
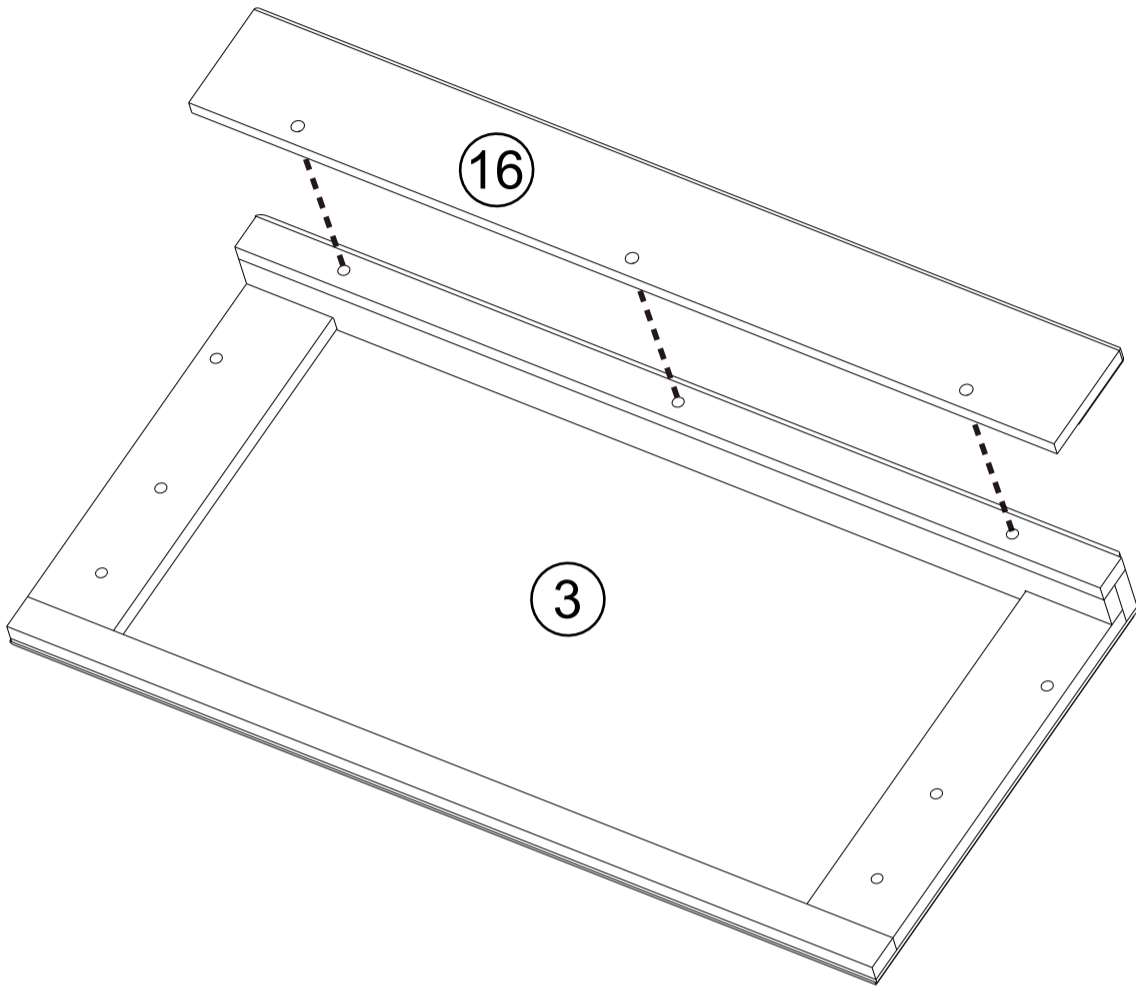

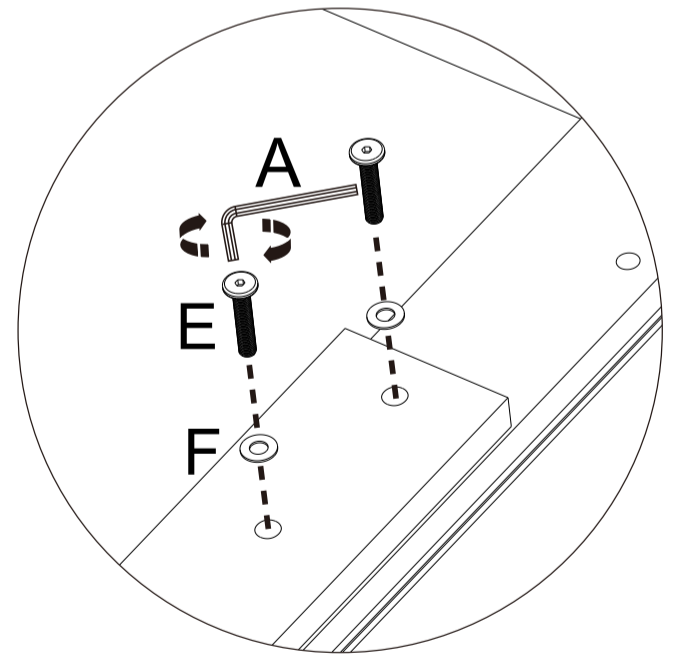
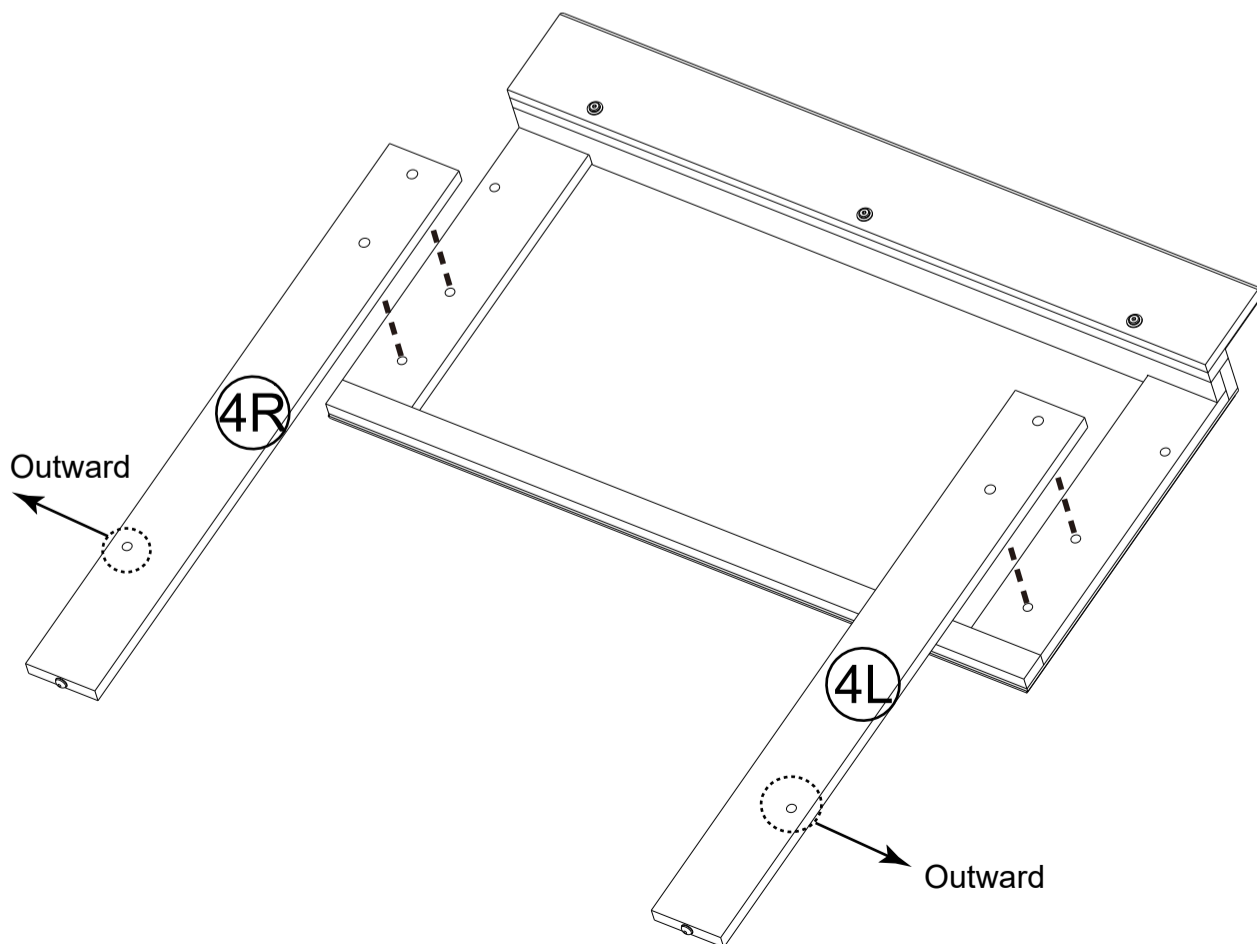

2

A x 1	E x 4 M8 x 40mm	F x 4	
-------	--------------------	-------	--

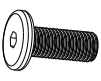

3

A x 1 	C x 8  M8 x 20mm	R x 4 	
--	---	---	--

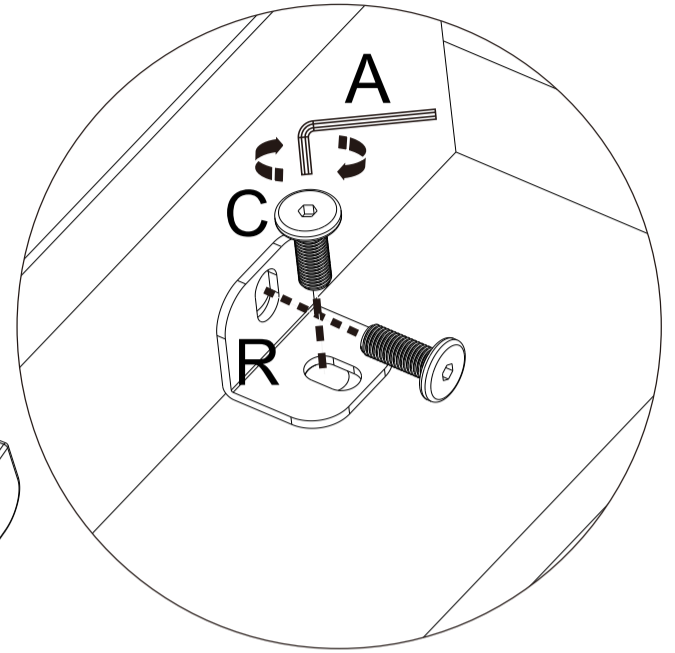
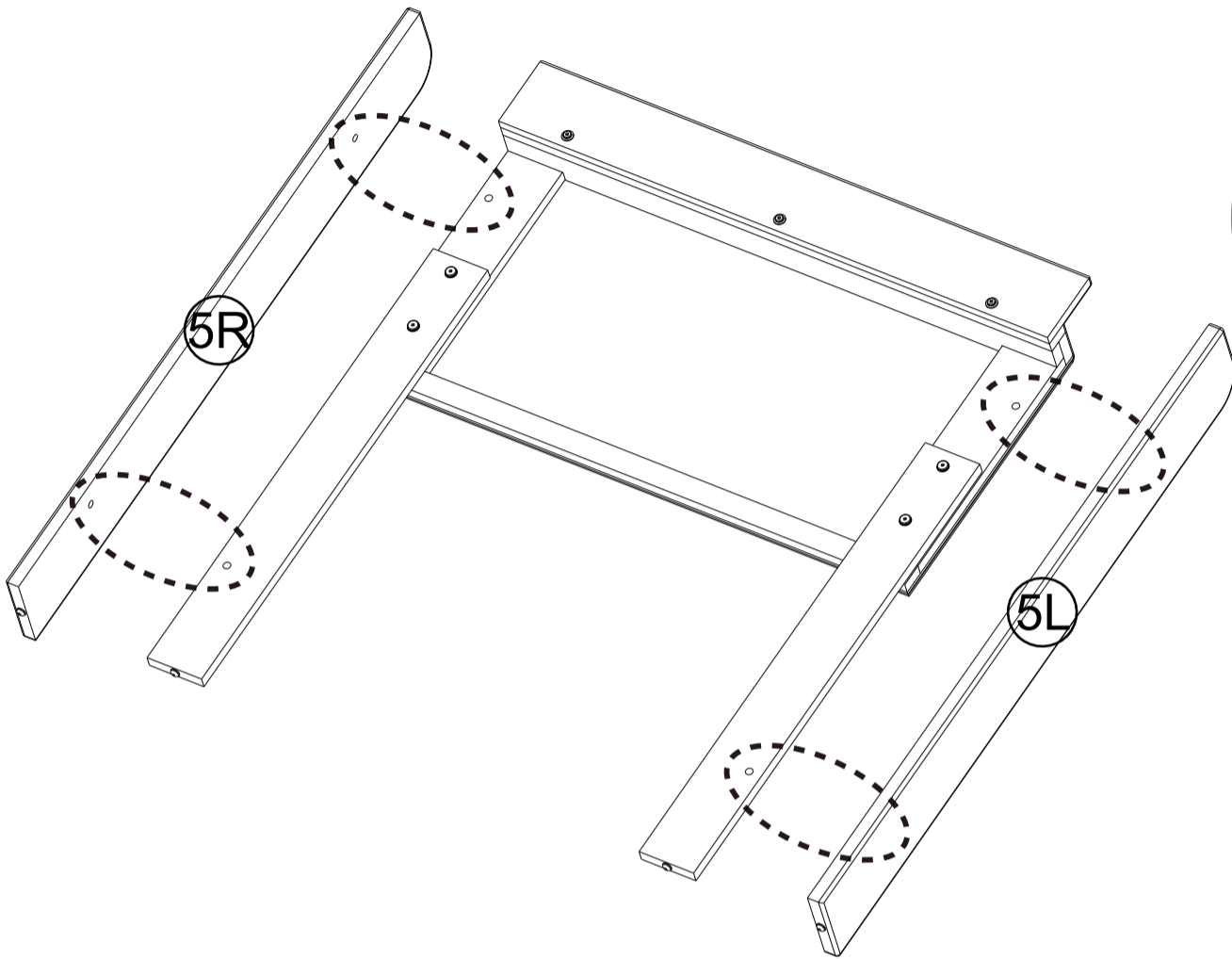



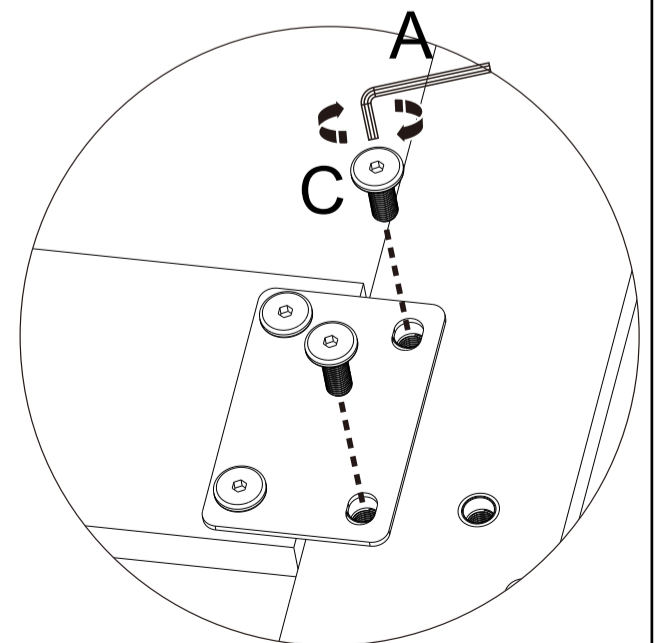
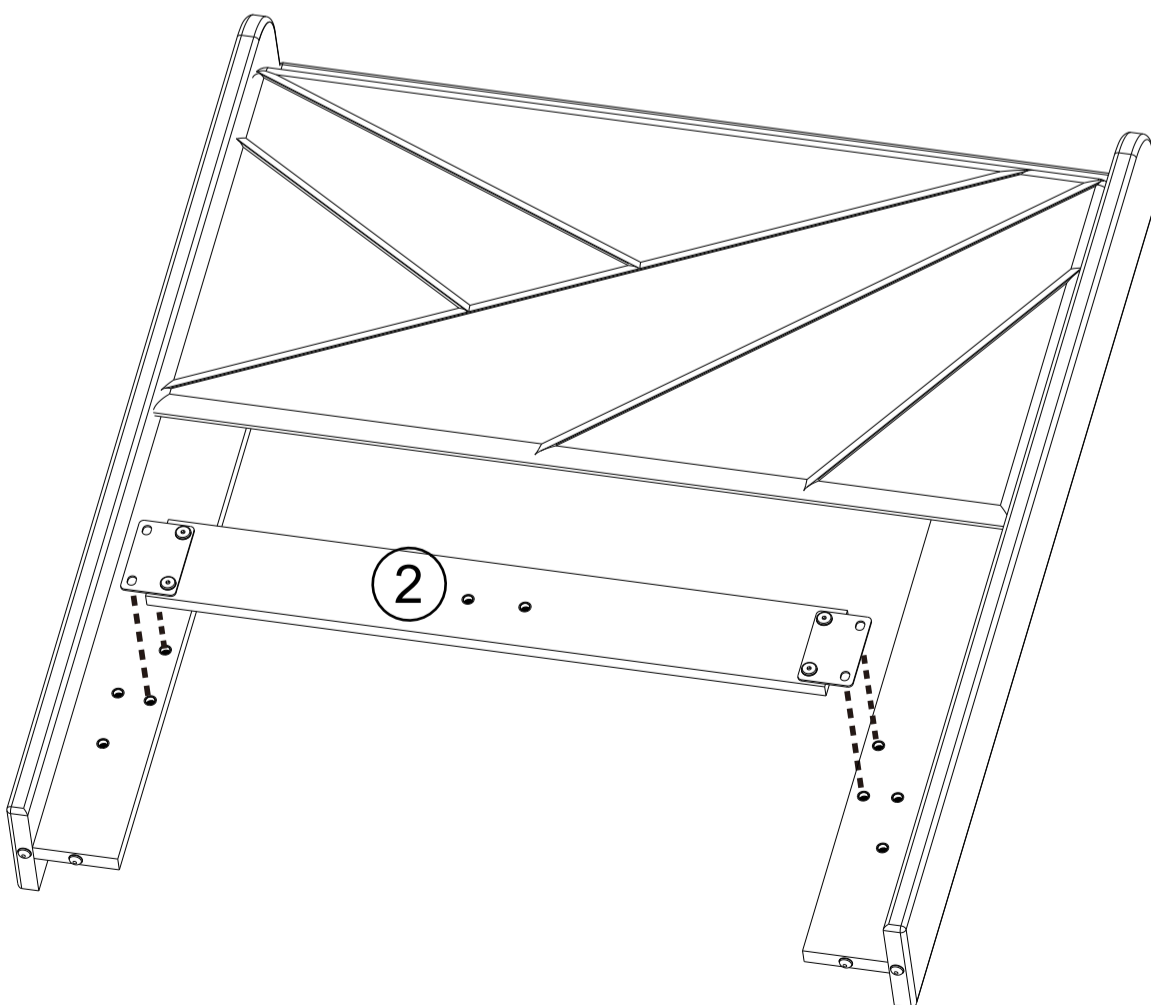

4

A x 1 	C x 4  M8 x 20mm		
--	---	--	--

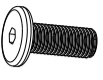

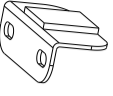
5

A x 1	C x 4	K x 2	L x 2	S x 2	
	 M8 x 20mm	 M4 x 40mm			

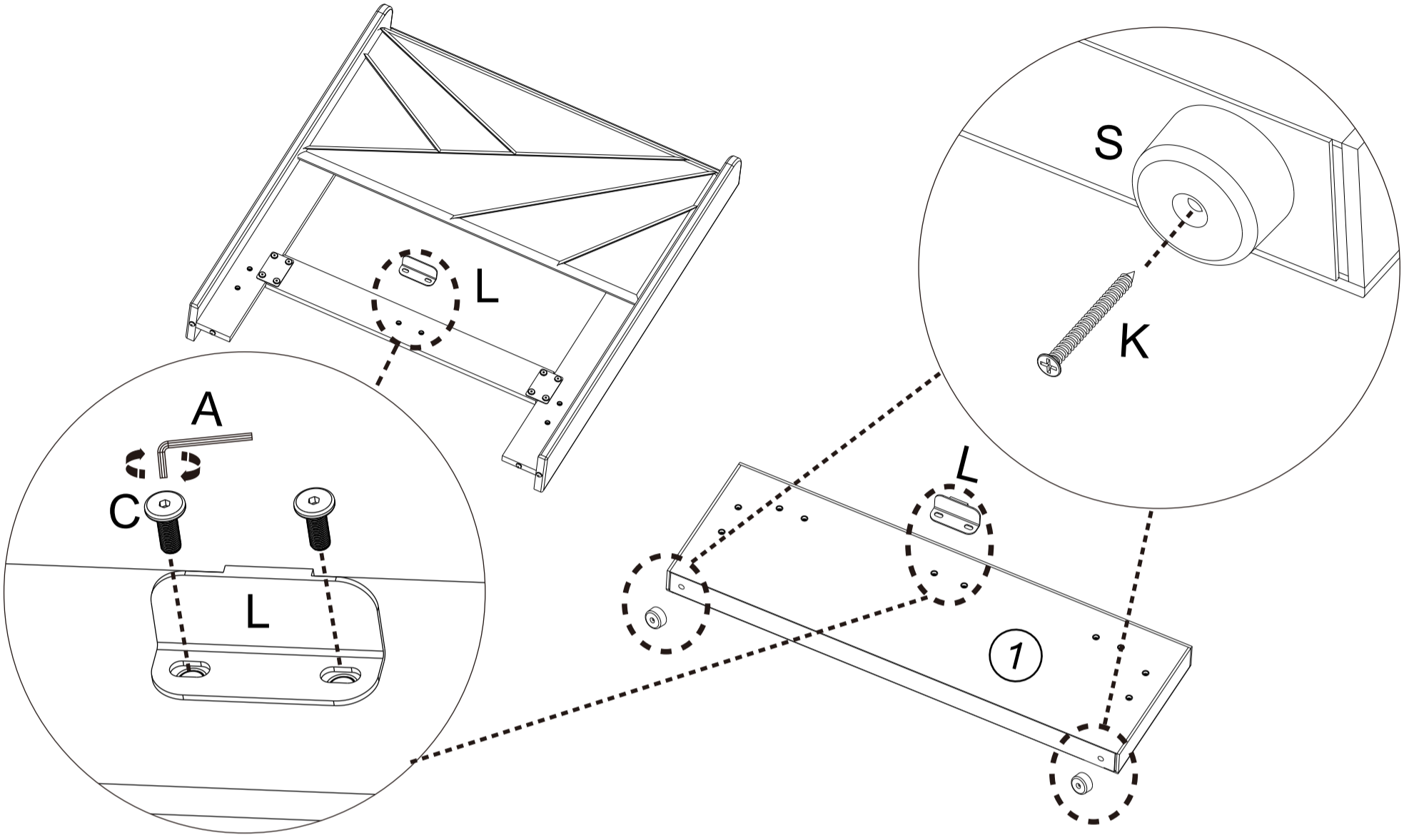

6

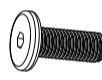
A x 1	C x 8	
	 M8 x 20mm	

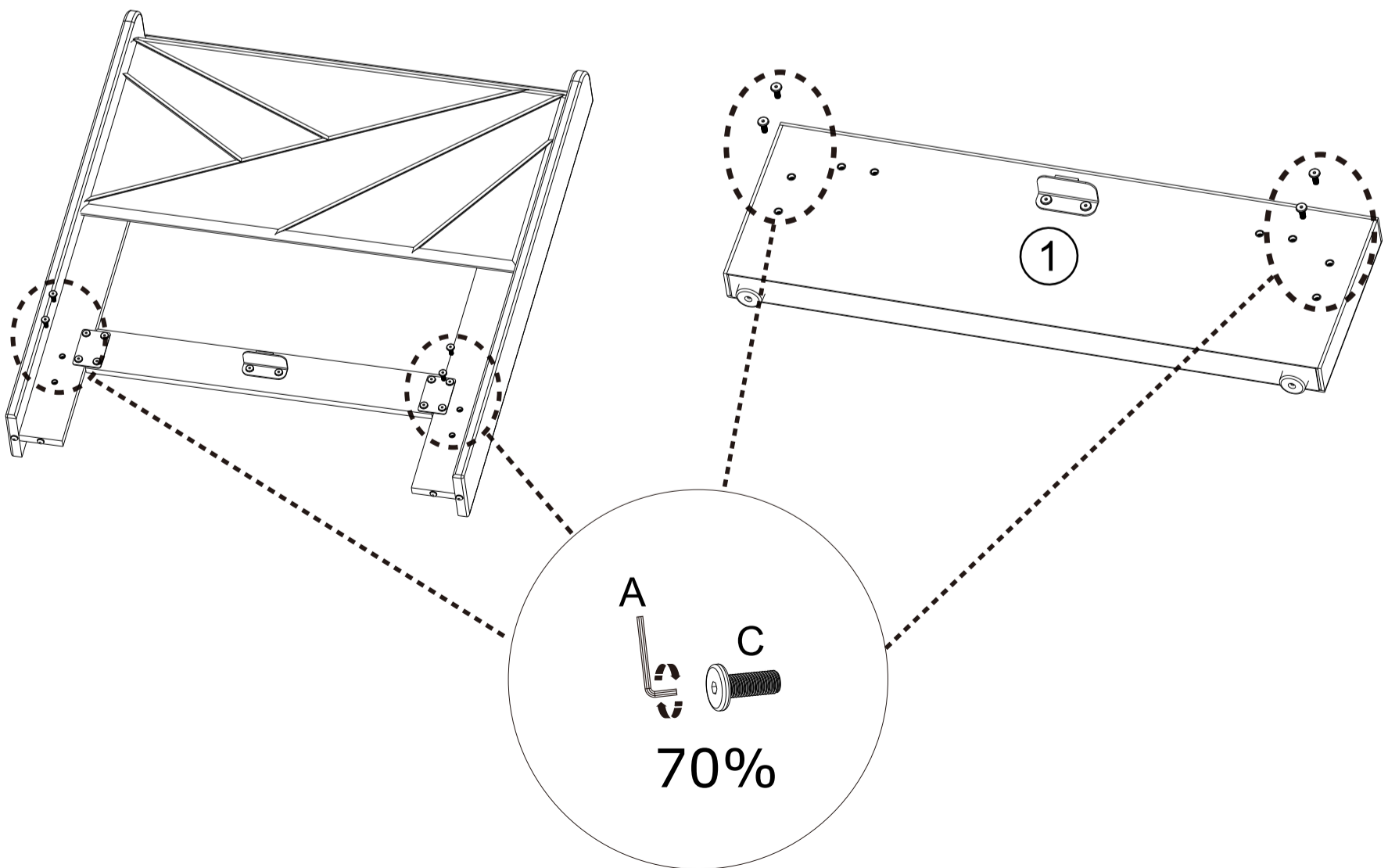

7

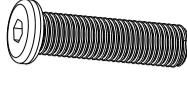
A x 1 	D x 8 M8 x 30mm 	J x 8 	
--	---	---	--

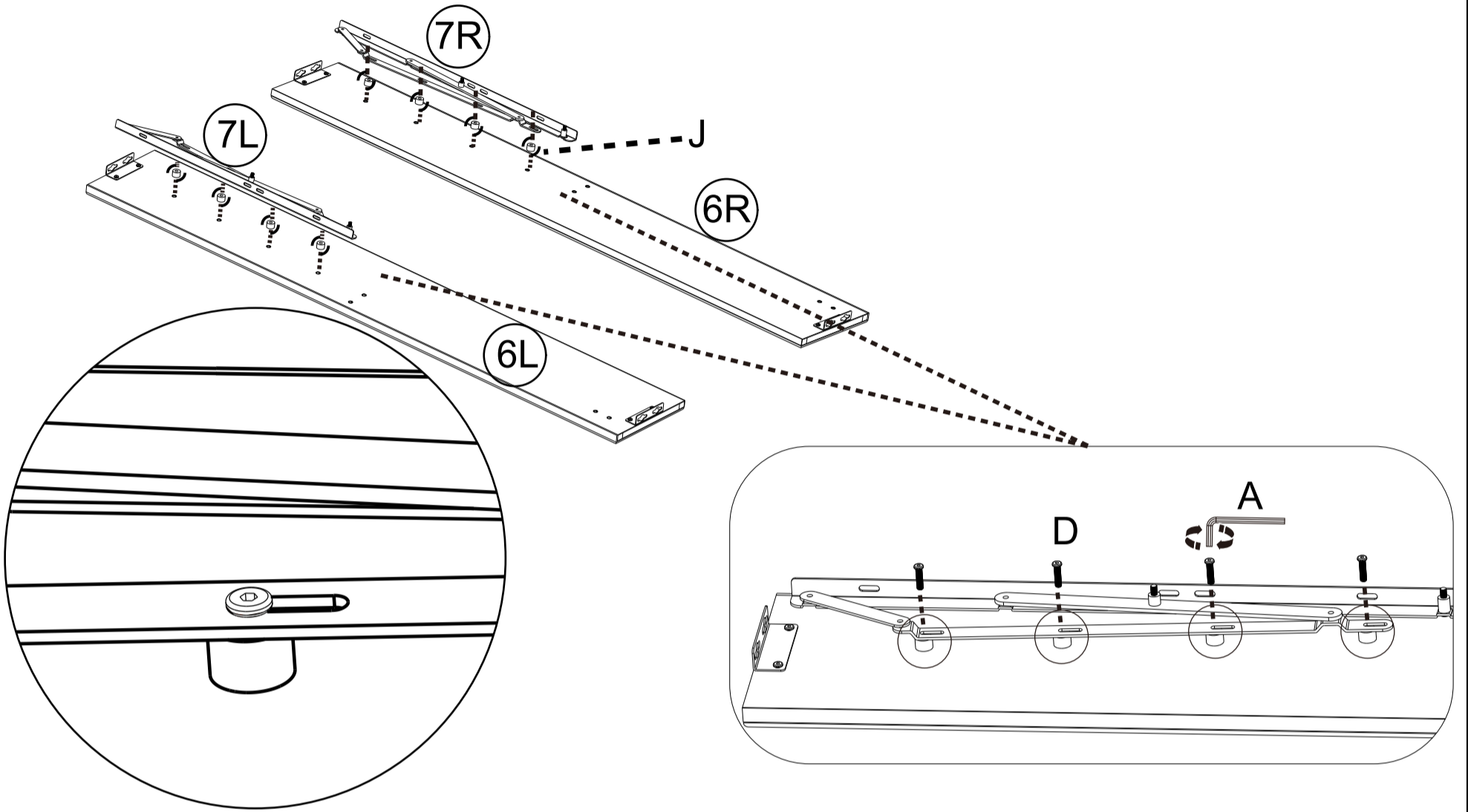

8

A x 1 	
--	--

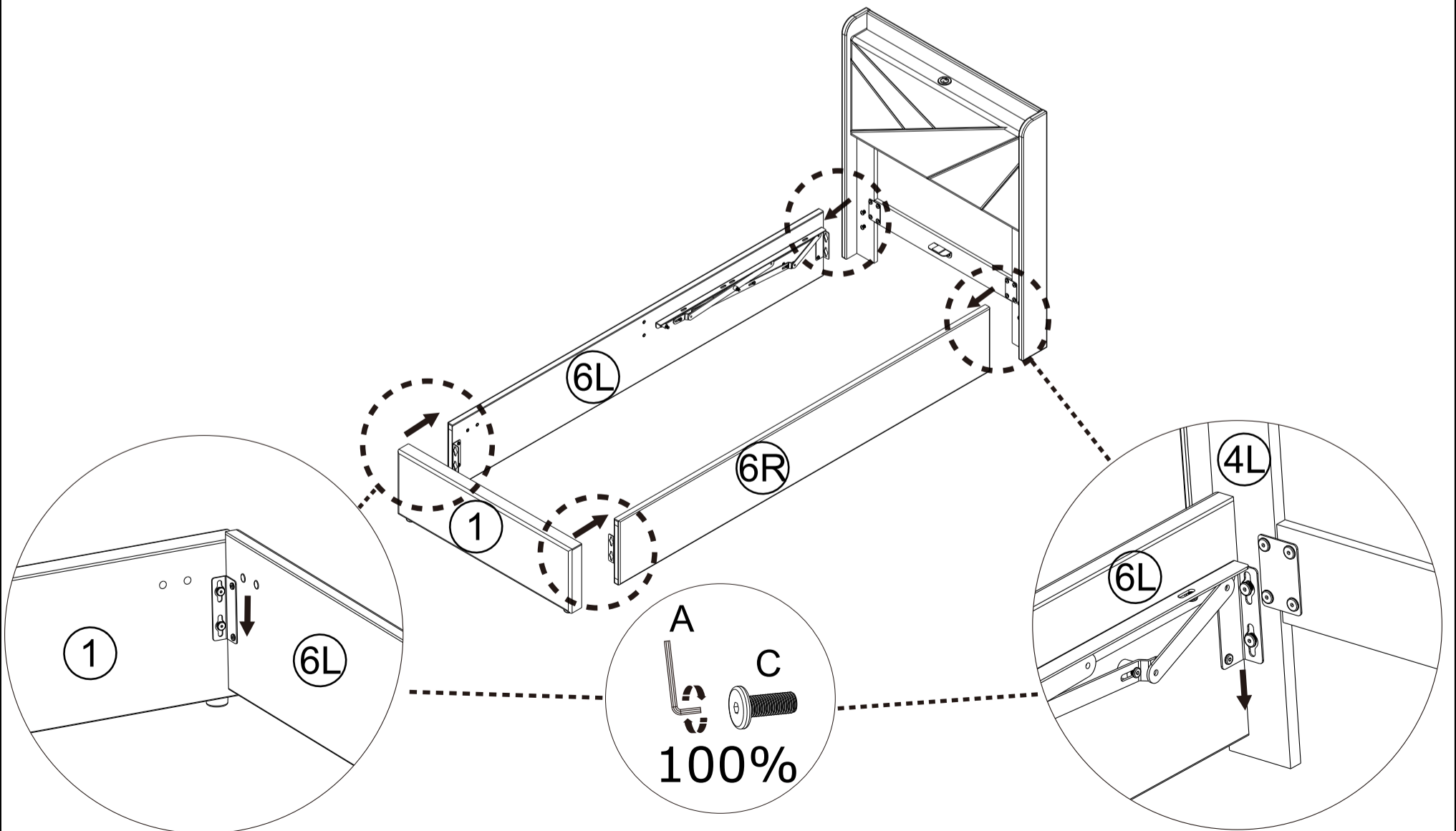

9

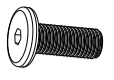
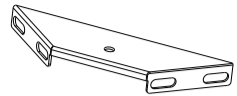
A x 1 	C x 8 M8 x 20mm 	M x 2 
--	---	---

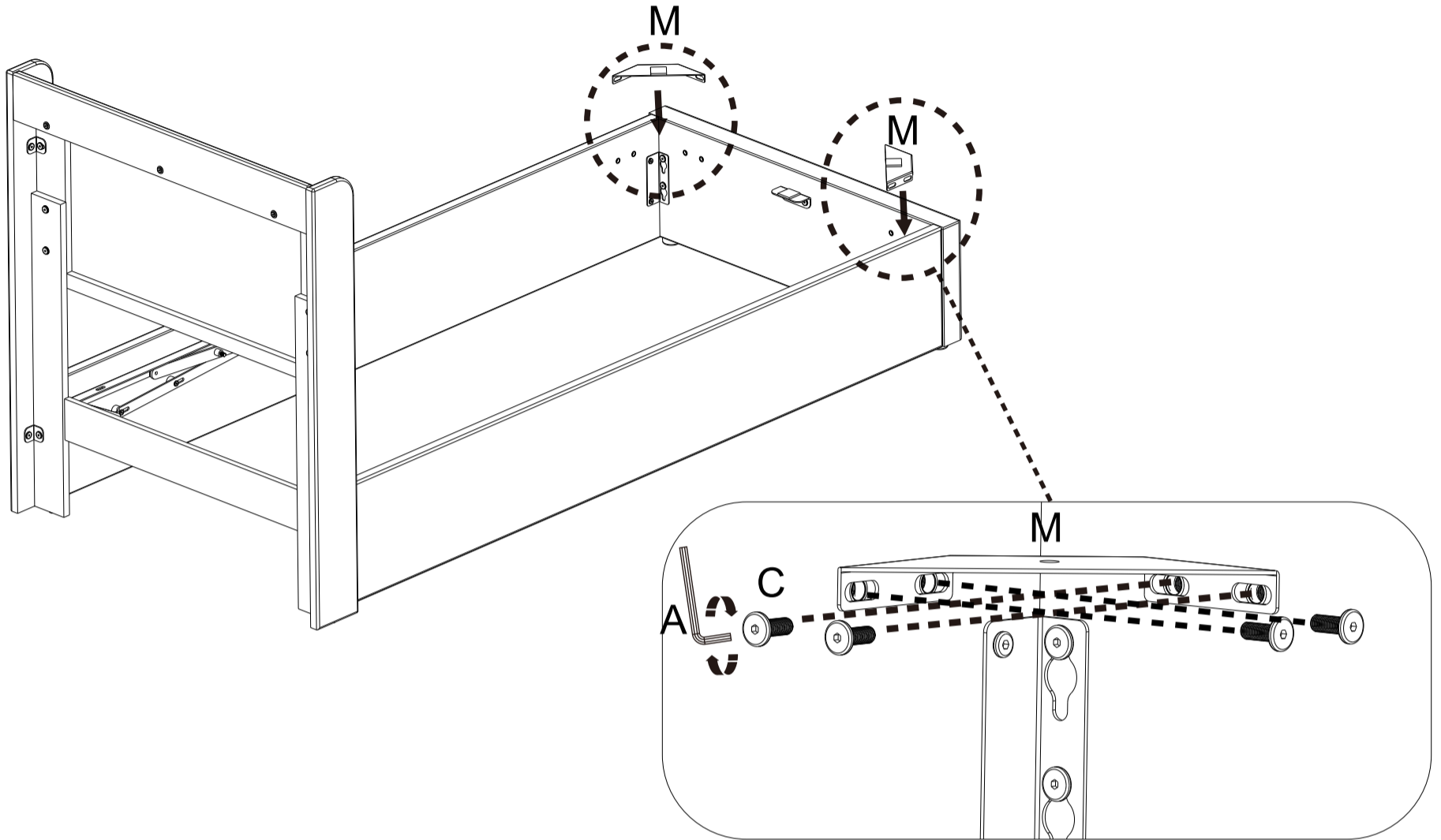

10

A x 1 	B x 4 M8 x 18mm 
--	---

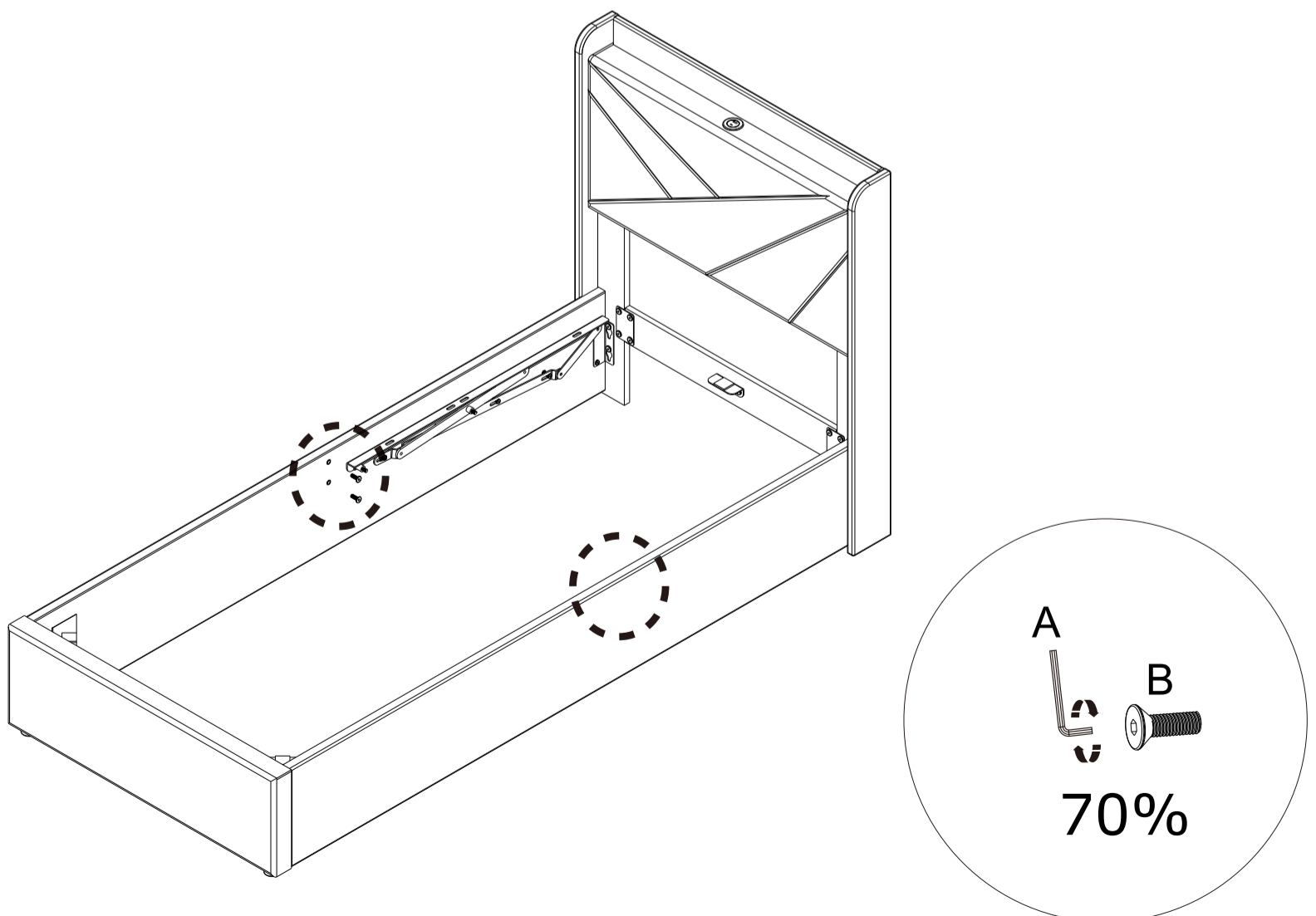



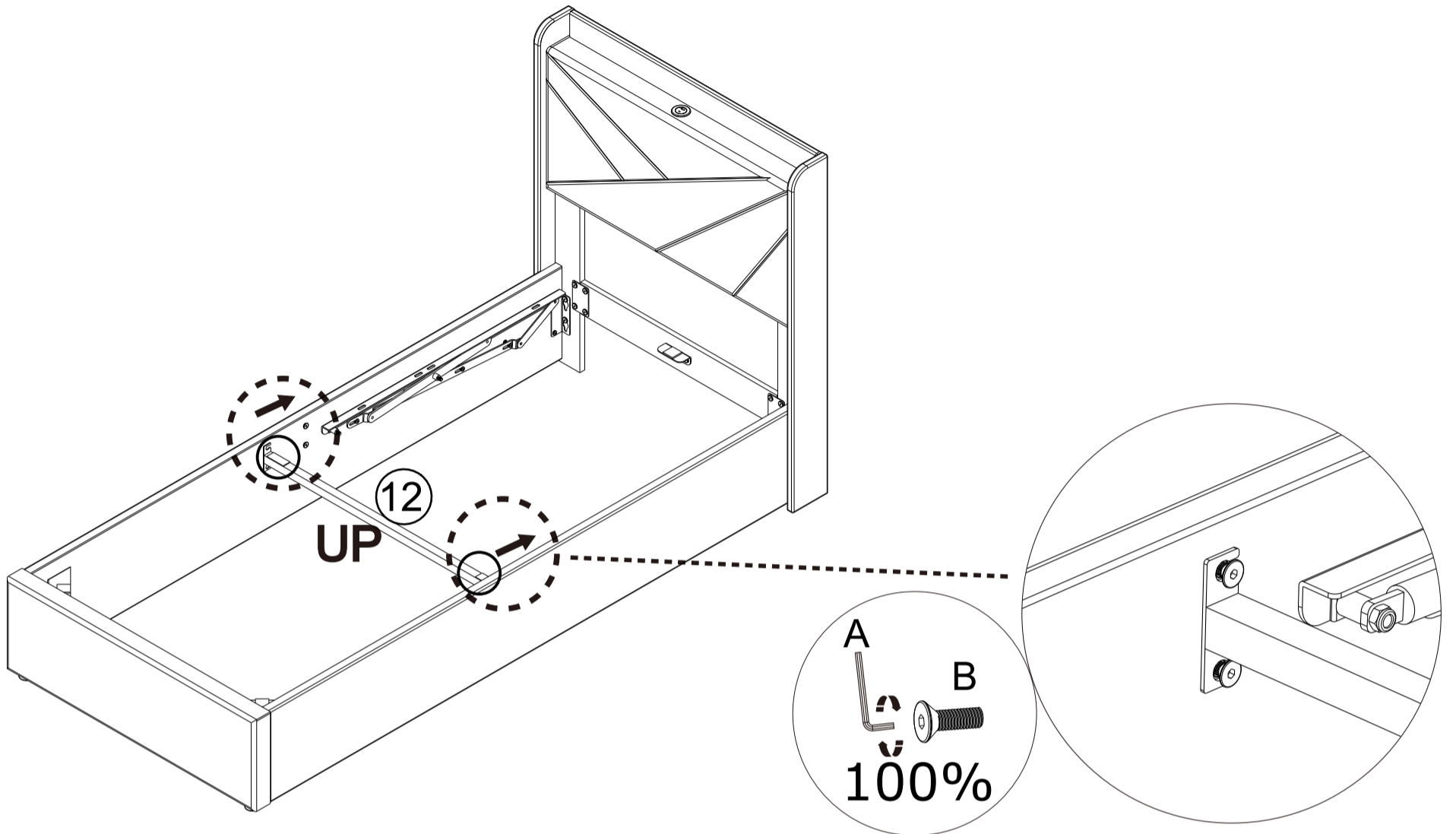
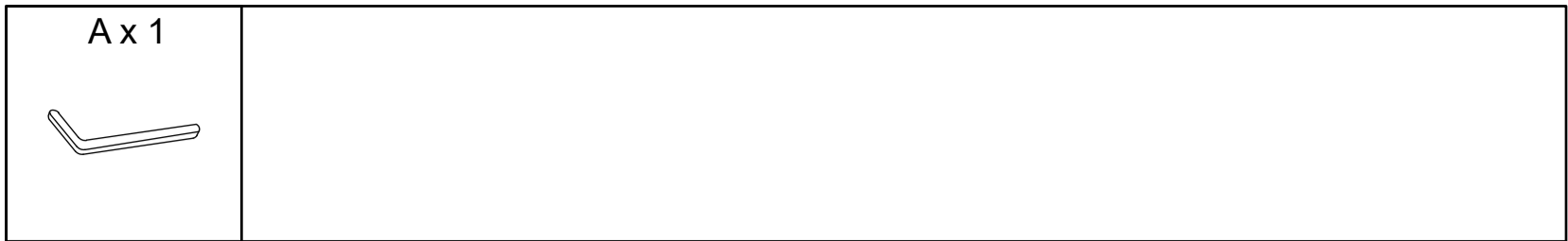

11

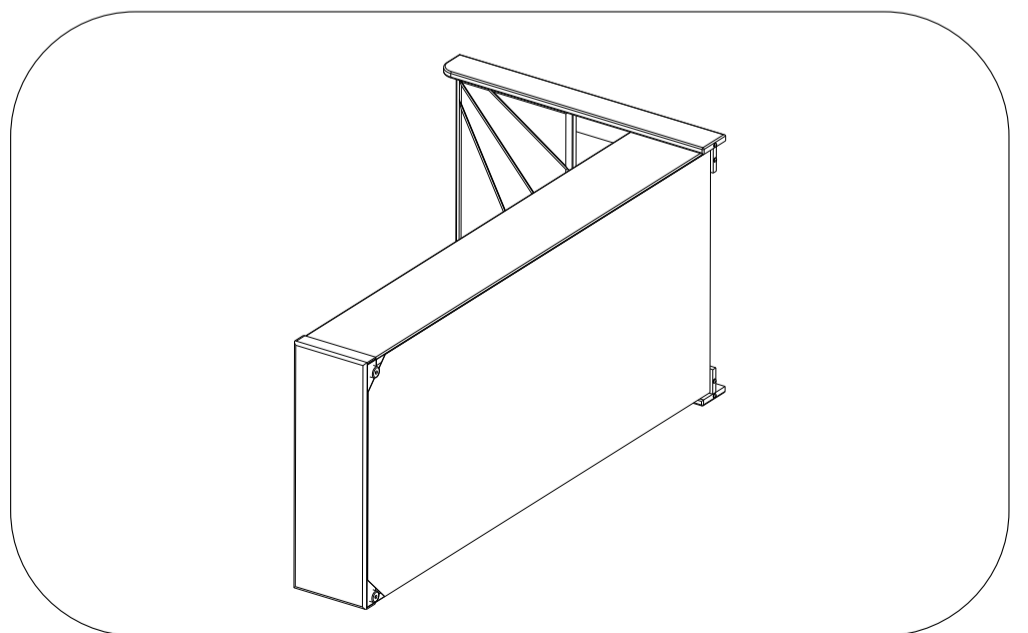
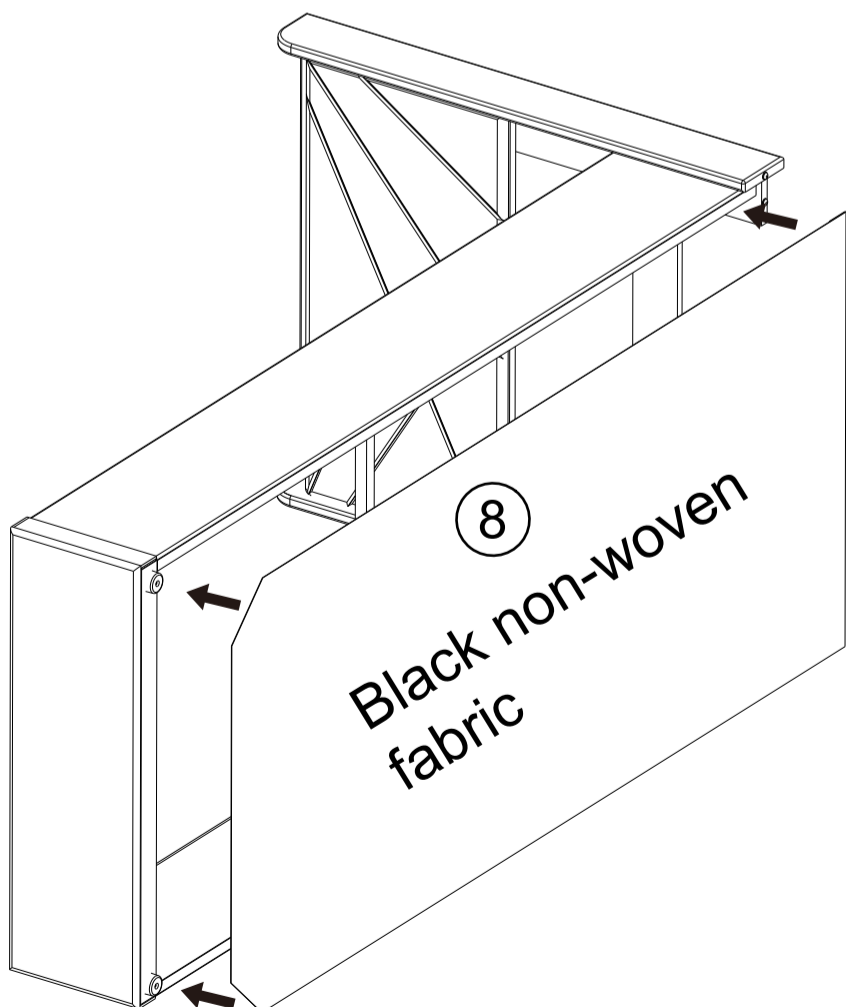

12



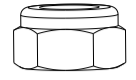

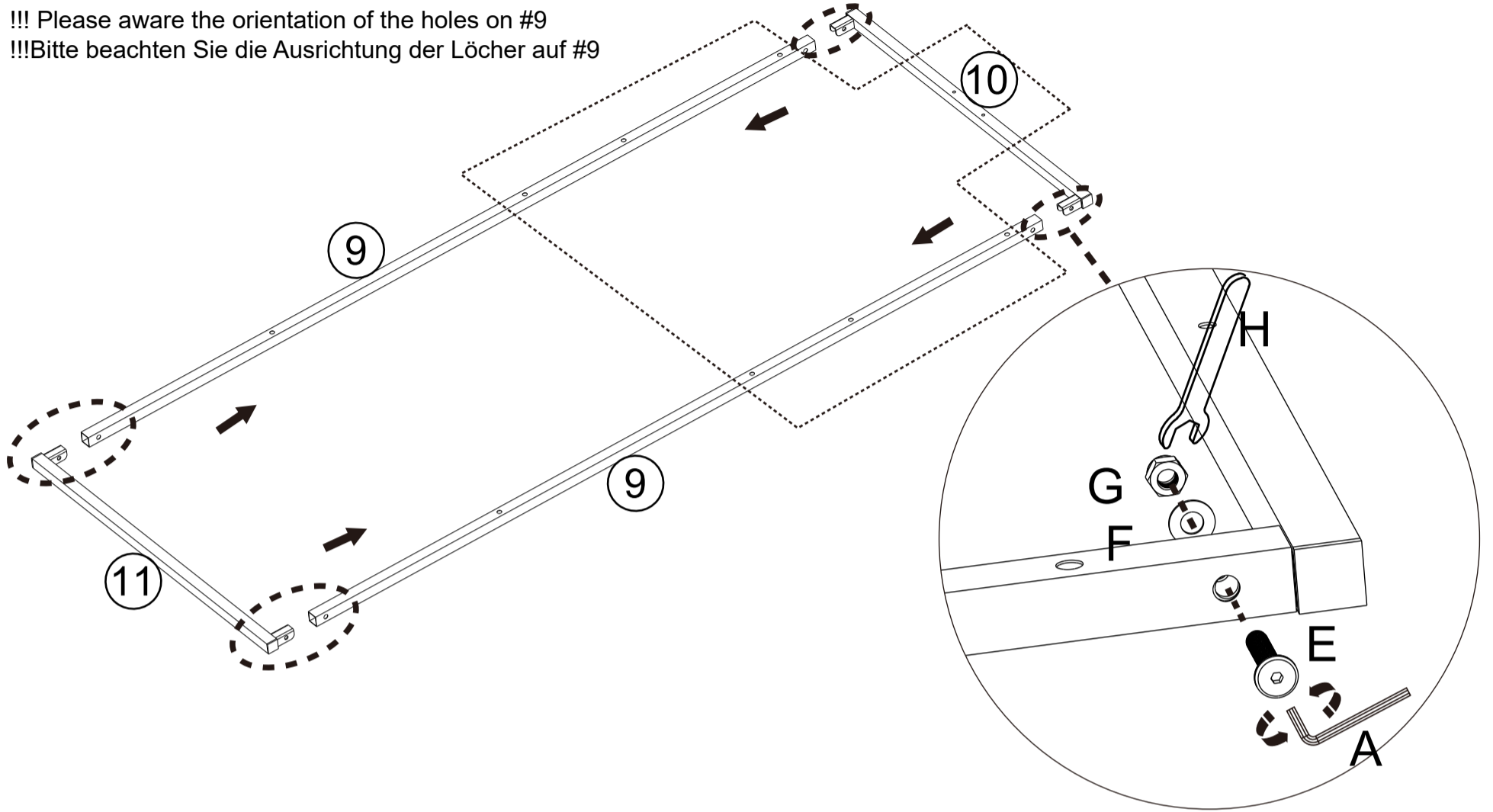

# 13

A x 1	E x 4 M8 x 40mm	F x 4	G x 4 M8	H x 1	
					

!!! Please aware the orientation of the holes on #9  
 !!!Bitte beachten Sie die Ausrichtung der Löcher auf #9



# 14

A x 1	E x 6 M8 x 40mm	G x 6 M8	H x 1	
				

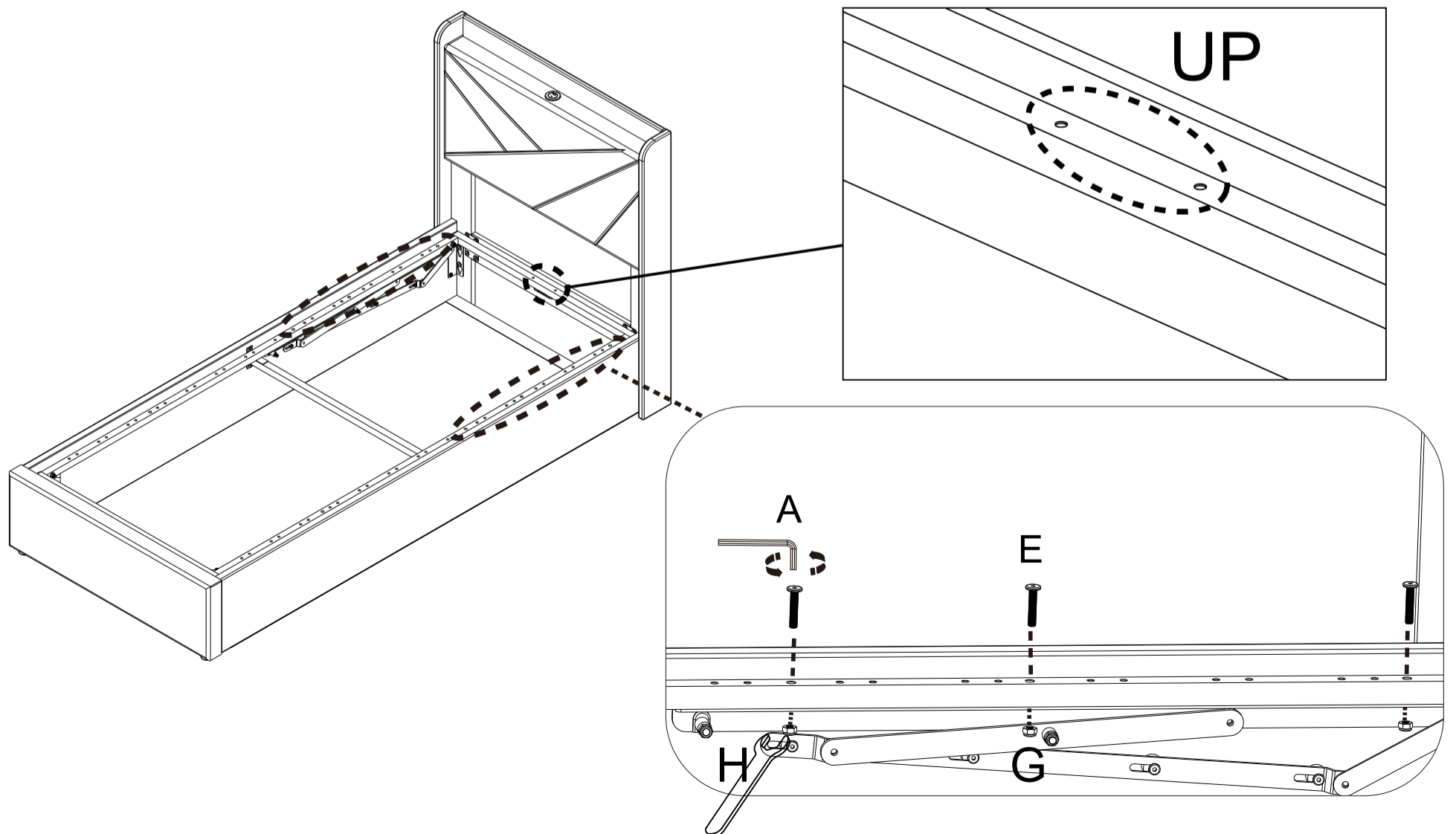

15

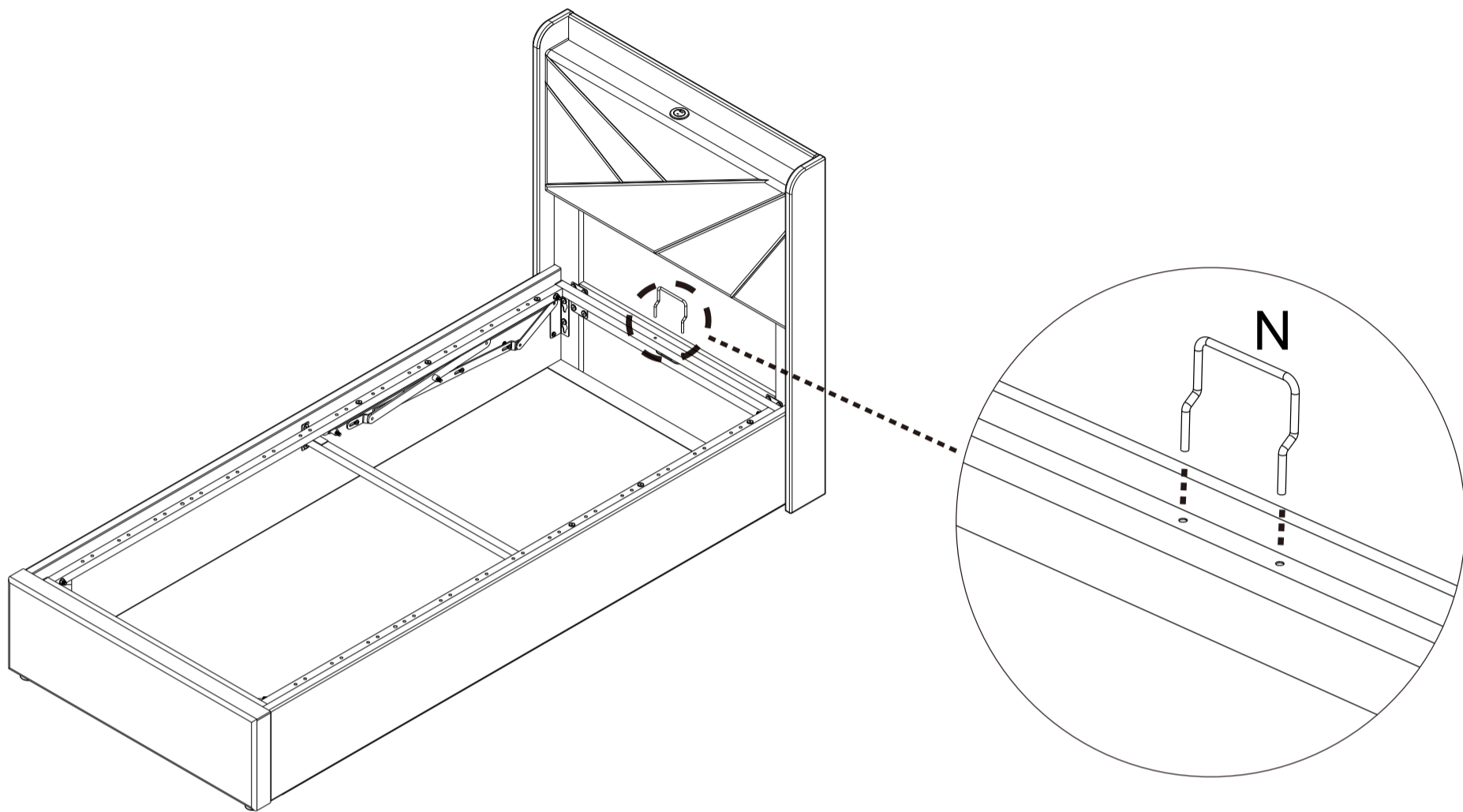
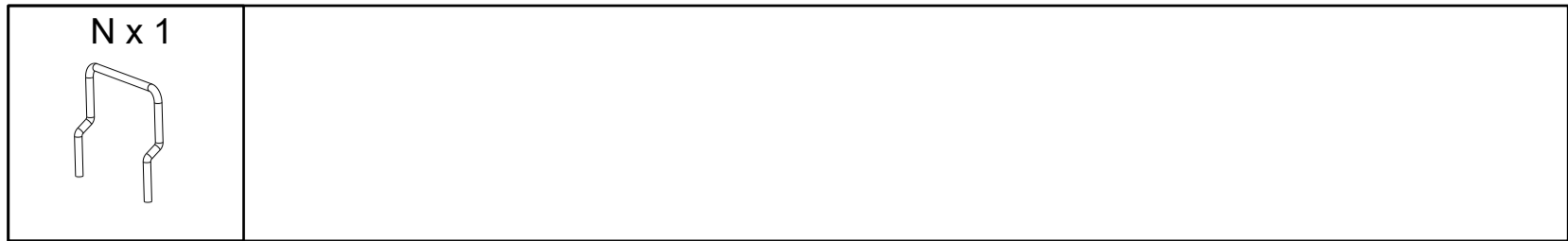

16

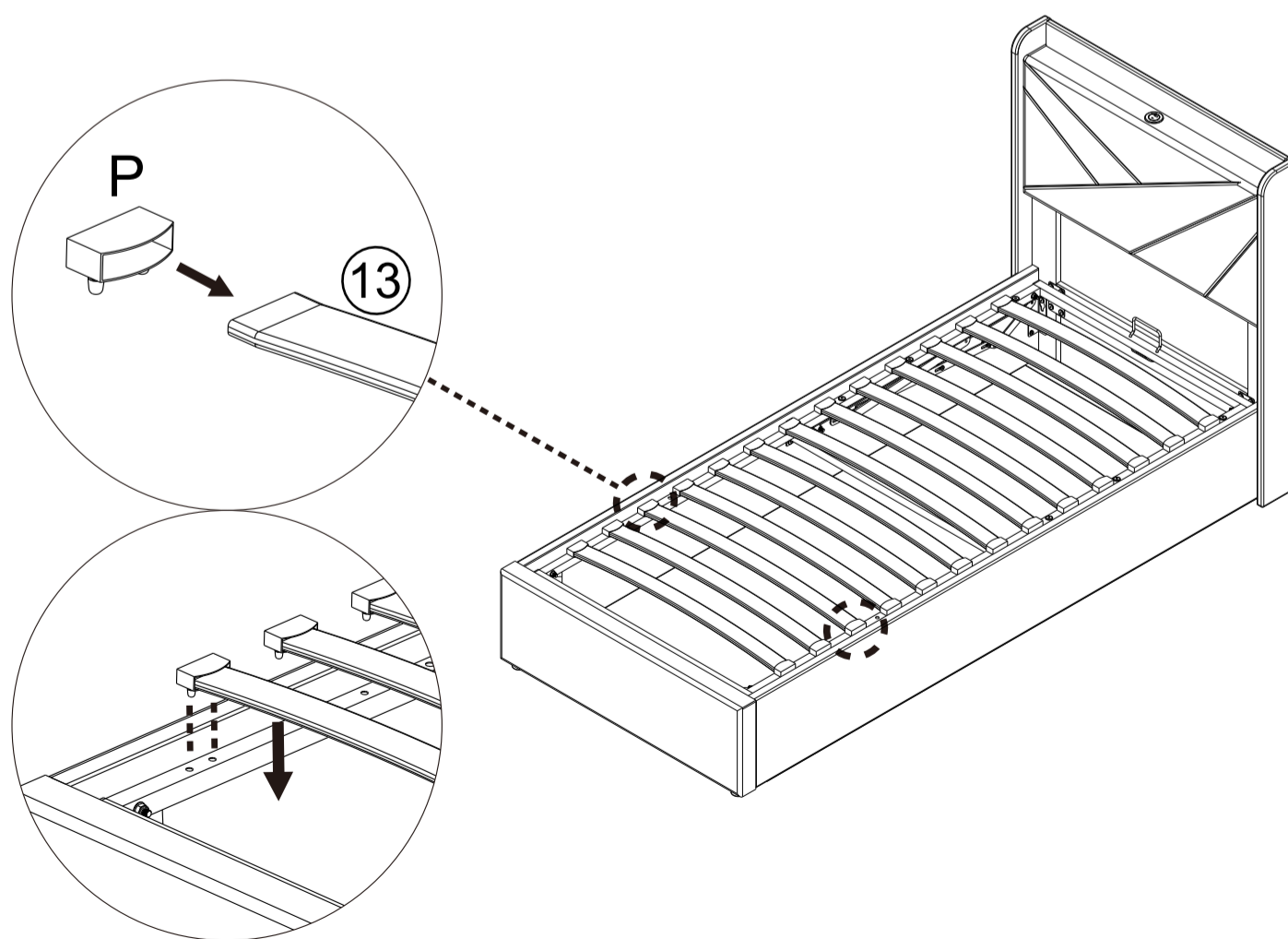

17

G x 4  M8	H x 1 	
--	--	--

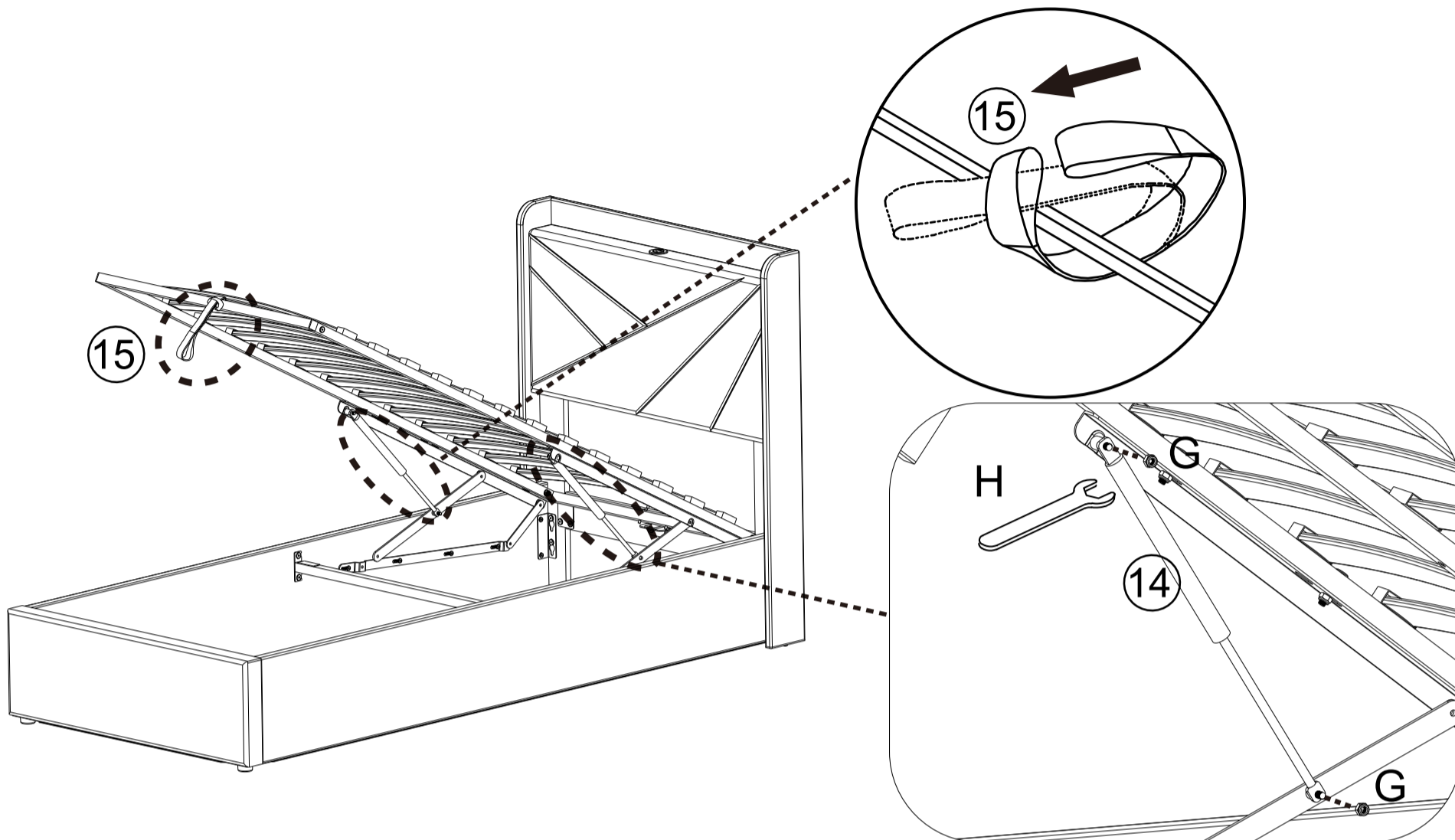

18

**WHY WON'T MY HYDRAULIC BED STAY DOWN?**

1. In fact, nine times out ten the reason why hydraulic won't close is because you need to put your mattress on top of the bed. Yep, it really is that easy. This is because the hydraulic pistons need the weight of the mattress to provide enough pressure to close your bed.

2. However, what if you've put your mattress on your bed and you're one of the unlucky ones who finds that their hydraulic bed still won't stay down? As previously mentioned, they require pressure in order to close. However, occasionally as well as placing the mattress on the bed you will initially have to apply some physical force yourself to close the bed. Don't worry you won't break it! ! !

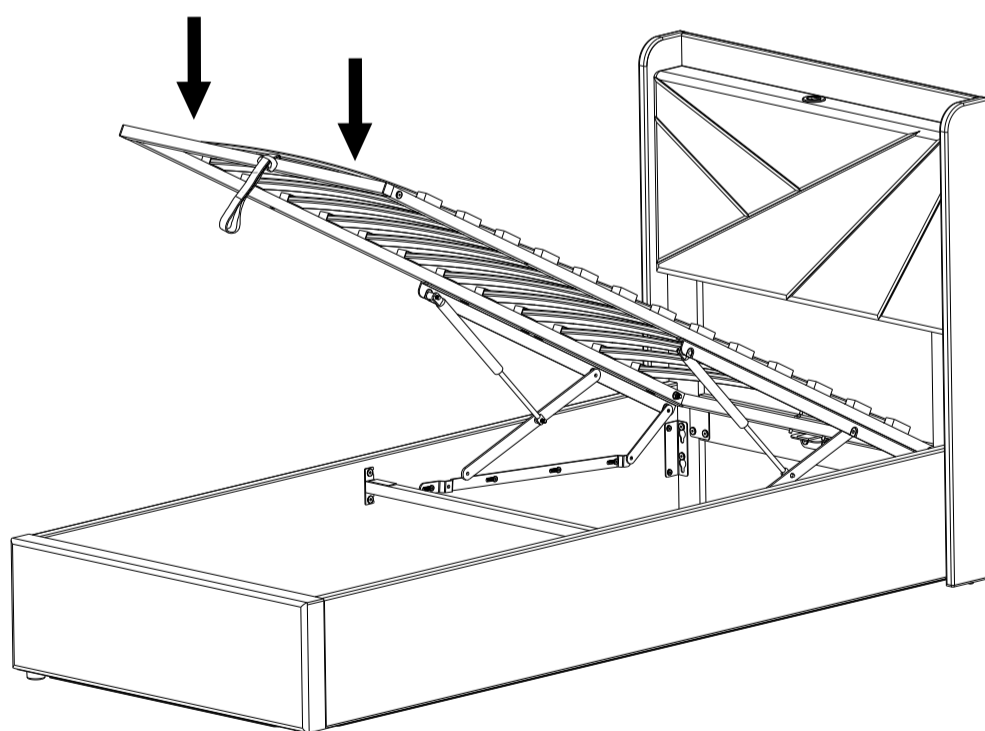

**WARUM BLEIBT MEIN HYDRAULISCHES BETT NICHT UNTEN?**

1. In neun von zehn Fällen liegt der Grund dafür, dass sich die Hydraulik nicht schließen lässt, darin, dass Sie Ihre Matratze oben auf das Bett legen müssen. Ja, es ist wirklich so einfach. Das liegt daran, dass die Hydraulikkolben das Gewicht der Matratze benötigen, um genügend Druck zum Schließen des Bettes zu erzeugen.

2. Was aber, wenn Sie Ihre Matratze auf Ihr Bett gelegt haben und zu den Unglücklichen gehören, die feststellen, dass ihr hydraulisches Bett trotzdem nicht unten bleibt? Wie bereits erwähnt, muss man Druck ausüben, um sie zu schließen. Gelegentlich müssen Sie jedoch nicht nur die Matratze auf das Bett legen, sondern zunächst selbst etwas Kraft aufwenden, um das Bett zu schließen. Keine Sorge, Sie werden es nicht kaputt machen! ! !

19

Q x 1

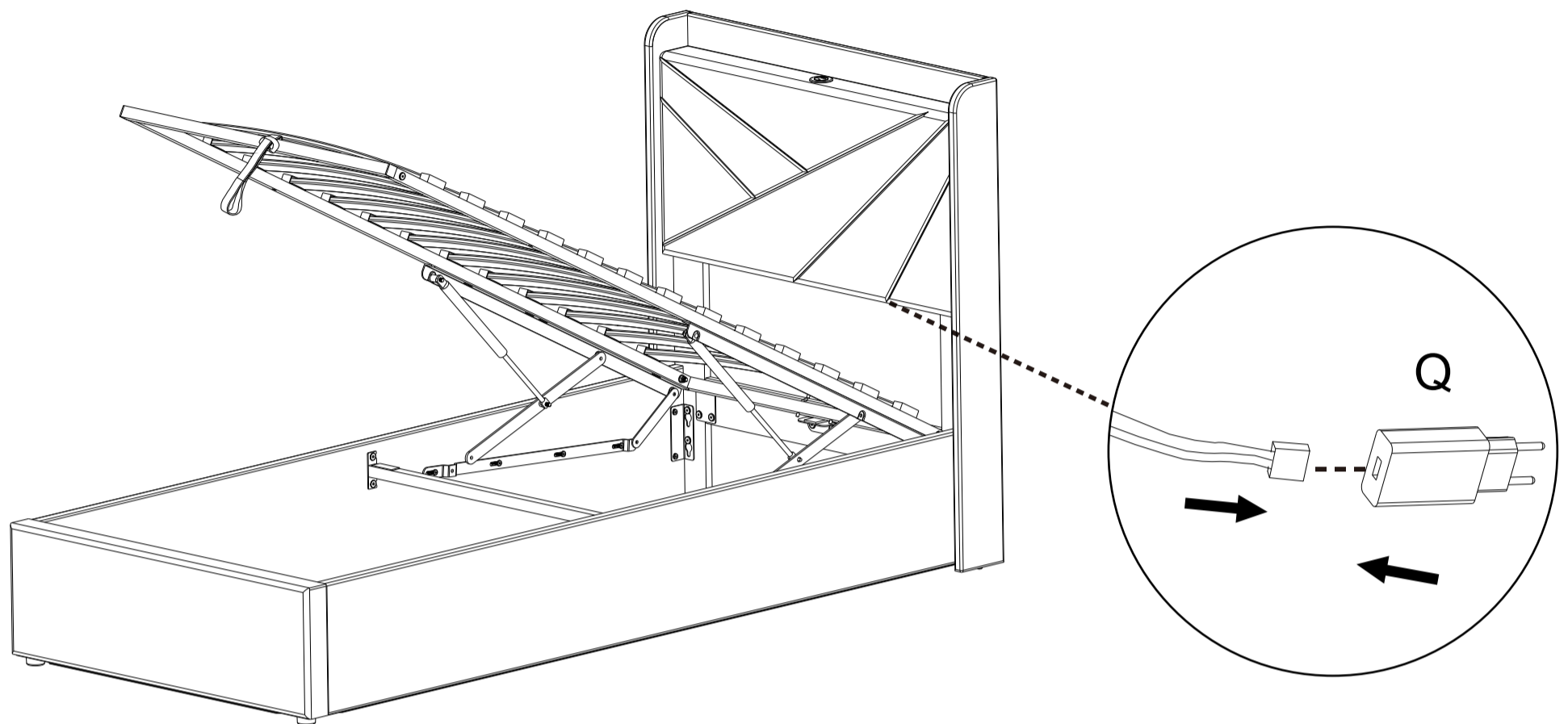
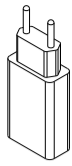

### IMPORTANT NOTICE OTTOMAN OPERATING INSTRUCTIONS

Once your bed frame is completely assembled, the slat unit will not operate correctly unless a mattress is placed on the slat frame. Position the mattress on the slat frame whilst it is in the closed position.

- It takes a lot of force to make the initial movement of the ottoman. This is a design feature of the product so that it does not fall shut - the nearer to being closed the ottoman is, the easier it is to move. When the ottoman is almost shut, it will close completely under its own weight.

When lowering the slat unit for the first time, take care to make sure it does not rub unevenly on the inside face of the side rails. If it does, the bed has been assembled slightly out of square. This can be rectified by moving the foot end of the bed slightly to the left or right whilst leaving the head

### PISTONS

The pistons used in the construction of this product are extremely strong and cannot be operated by hand when taken off the ottoman. All pistons are tested for correct pressure and operation before being attached to the slat unit.

Initially it might appear that the pistons are very stiff when opening and closing the ottoman.

### THIS IS PERFECTLY NORMAL

When fully assembled and the mattress is in position, please raise and lower the ottoman 4/5 times to ensure the gas piston are fully lubricated.

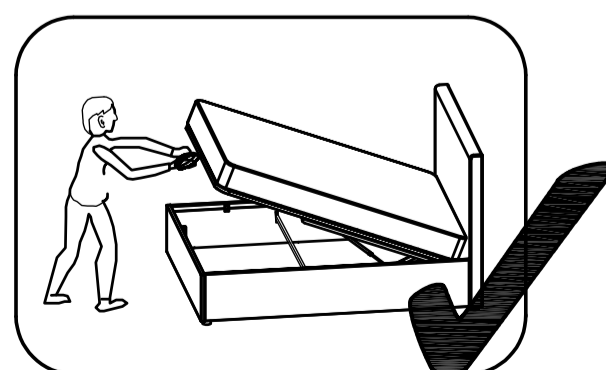
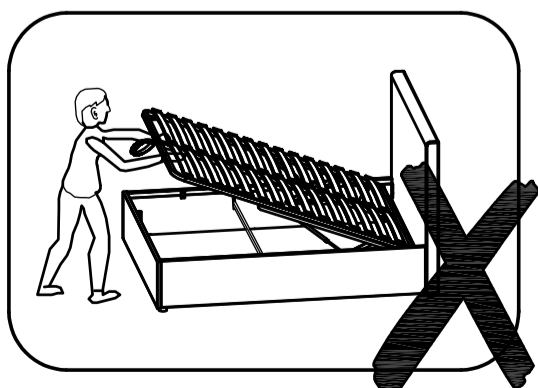

# Certificate of Compliance

Certificate Number: DL-2022072129C

**Applicant:** Eyue Technology Co., Ltd  
2F, XINWANGYUAN HIGH-TECH INDUSTRIAL PARK, ZHANGMUTOU TOWN, DONGGUAN, GUANGDONG, 523627 CHINA

**Manufacturer:** Eyue Technology Co., Ltd  
2F, XINWANGYUAN HIGH-TECH INDUSTRIAL PARK, ZHANGMUTOU TOWN, DONGGUAN, GUANGDONG, 523627 CHINA

**Product:** USB Charger

**M/N:** EY-U222  
EY-U112, EY-U212, EY-U312, EY-U412, EY-U612, EY-U122, EY-U322, EY-U422, EY-U132, EY-U232, EY-U332, EY-U432, EY-U142, EY-U242, EY-U342, EY-U442, EY-U152, EY-U252, EY-U352, EY-U452, EY-UXXX, EY-U512, EY-U712, EY-U812, EY-U522, EY-U622, EY-U722, EY-U822, EY-U532, EY-U632, EY-U732, EY-U832, EY-U542, EY-U642, EY-U742, EY-U842, EY-U552, EY-U652, EY-U752, EY-U852

**Test Standard:** EN 55015:2013+A1:2015  
EN 61000-3-2:2014, EN 61000-3-3:2013  
EN 61547:2009  
EN 61000-4-2:2009, EN 61000-4-3: 2006+A1:2008+A2:2010  
EN 61000-4-4:2012, EN 61000-4-5:2014, EN 61000-4-6:2014  
EN 61000-4-8:2010, EN 61000-4-11:2004

The EUT described above has been tested by us with the listed standards and found in compliance with the council EMC directive 2014/30/EU. It is possible to use CE marking to demonstrate the compliance with this EMC Directive. It is only valid in connection with the test report number: DL-2022072129E.





®

Dongguan Anci Electronic Technology Co., Ltd.

Add.: 1-2 Floor, Building A, No.11, Headquarters 2 Road, Songshan Lake

Hi-tech Industrial Development Zone, Dongguan City, Guangdong Pr., China.

Tel: 86 -769 -8507 5888 Fax: 86 -769 -8507 5898 Web: www.anci.com

# CERTIFICATE OF CONFORMITY

Certificate No. 18AE08069E 003

This Certificate of Conformity is hereby issued to the product designated below

**Report No.** : EA1808069E 03001  
**Applicant Address** : Huizhou Guoatong Technology Co., Ltd  
4, 5F (PLANT B) NO.2 RUNZE RD SOUTH HIGHTECH  
INDUSTRIAL PARK HUIAO AVENUE HUIZHOU  
GUANGDONG PR 516000 CHINA  
**Manufacturer Address** : Huizhou Guoatong Technology Co., Ltd  
4, 5F (PLANT B) NO.2 RUNZE RD SOUTH HIGHTECH  
INDUSTRIAL PARK HUIAO AVENUE HUIZHOU  
GUANGDONG PR 516000 CHINA  
**Description of Product** : Power Adapter  
**Model No.** : GA-xxxxyyyV(xxx, yyy are variable, xxx=030-240,  
yyy=0100-3000)  
**Input Rating** : AC 100-240V, 0.6A, 50/60Hz  
**Output Rating** : 3.0-24.0Vdc, 0.1-3.0A  
**Test Standards** : EN 55032: 2015  
EN 55035: 2017  
EN 61000-3-2:2014  
EN 61000-3-3:2013

This certificate of conformity is based on evaluation of a sample of the above mentioned product. Technical report and documentation are at the license Holder's disposal. This is to certify that the tested sample is in conformity with the Council Directive 2014/30/EU, referred to as the EMC. It is possible to use CE marking to demonstrate the conformity with this EMC Directive.

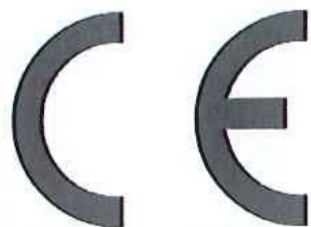

Test Laboratory

Fred Zhu  
Director

Date of Issue: Dec 19, 2018



This certificate of conformity is based on a single evaluation of the submitted sample(s) of the above mentioned product. It does not imply an assessment of the whole production and other relevant Directives have to be observed.



®

Dongguan Anci Electronic Technology Co., Ltd.

Add.: 1-2 Floor, Building A, No.11, Headquarters 2 Road, Songshan Lake  
Hi-tech Industrial Development Zone, Dongguan City, Guangdong Pr., China.

Tel: 86 -769 -8507 5888 Fax: 86 -769 -8507 5898 Web: www.anci.com

# CERTIFICATE OF CONFORMITY

Certificate No. 18AS08069L 368A

The following product has been tested by DongGuan Anci Electronic Technology Co., Ltd. with the listing standards and found in conformity with the **EC Council Directive of 2014/35/EU**. It is possible to use CE marking to demonstrate the conformity with this **LVD Directive**.

**Report No.** : SA1808069L 01001  
**Applicant** : Huizhou Guoatong Technology Co., Ltd  
**Address** : 4, 5F (Plant B) No.2 Runze Rd., South Hightech Industrial  
Park, Huiao Avenue, 516000 Huizhou, Guangdong,  
PEOPLE'S REPUBLIC OF CHINA  
**Manufacturer** : Huizhou Guoatong Technology Co., Ltd  
**Address** : 4, 5F (Plant B) No.2 Runze Rd., South Hightech Industrial  
Park, Huiao Avenue, 516000 Huizhou, Guangdong,  
PEOPLE'S REPUBLIC OF CHINA  
**Description of Product** : Power Adapter  
**Model No.** : GA-xxxxyyyV(xxx, yyyy are variable, xxx=030-240,  
yyyy=0100-3000)  
**Input Rating** : 100-240V~ 0.6A 50/60Hz  
**Output Rating** : 3.0-24.0Vac, 0.1-3.0A  
**Test Standards** : EN 62368-1:2014+ A11:2017

The referred test report(s) show that the product complies with the essential requirements in the above listed standards. The applicant is authorized to use this certificate in connection with the EC declaration of conformity according to Annex 1 of the Directive.

## Test Laboratory

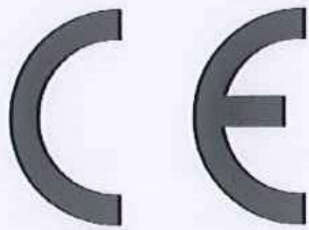

Eric Liu

Director

Date of Issue: Dec. 20, 2018

This certificate of conformity is based on a single evaluation of the submitted sample(s) of the above mentioned product. It does not imply an assessment of the whole production and other relevant Directives have to be observed.