

# N625P337264/N625P337265

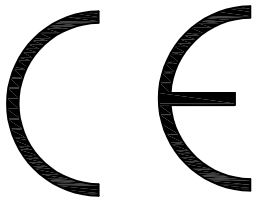

Product manual  
Gebrauchsanweisung  
Manuel du produit  
Manual del producto  
Manuale del prodotto

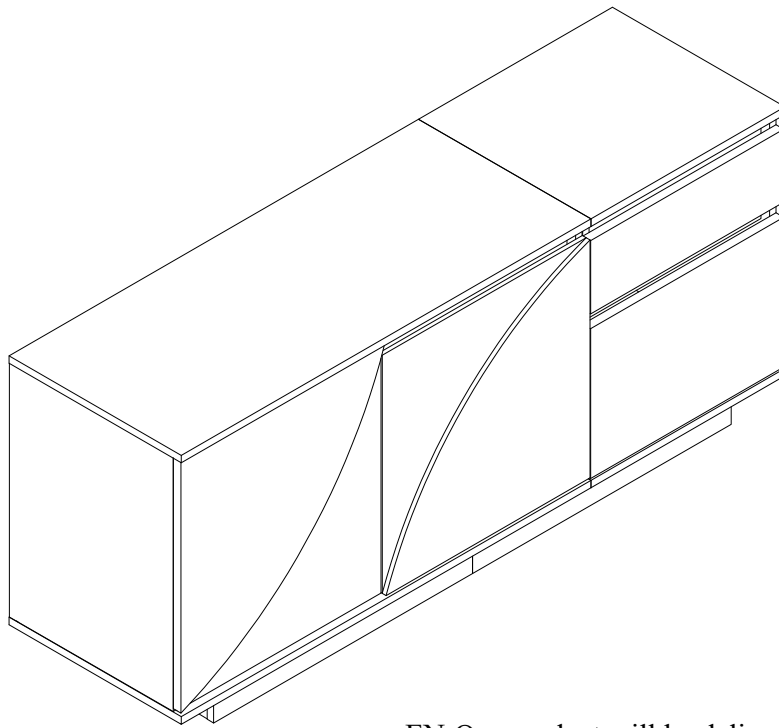

EN:Our product will be delivered to you in 2 packages.The delivery times of these 2 packages may differ, please be patient and thank you for your understanding

FR:Notre produit vous sera livré en 2 colis.Les délais de livraison de ces 2 colis peuvent différer,soyez patient et merci de votre compréhension.

DE:Unser Produkt wird Ihnen in 2 Paketen geliefert.Die Lieferzeiten dieser 2 Paket können abweichen, bitte haben Sie etwas Geduld und vielen Dank für Ihr Verständnis

IT:I nostri prodotti vengono trasportati in due pacchetti.I tempi di consegna dei due pacchetti sono diversi:abbiate pazienzae vi ringrazio per la vostra comprensione

ES:Nuestro producto se entrega en dos paquetes.El tiempo de entrega de estos dos paquetes es diferente.Por favor,sea paciente.Gracias por su comprensión.



Points de collecte sur [www.quefairedemesdechets.fr](http://www.quefairedemesdechets.fr)  
Privilégiez la réparation ou le don de votre appareil !

Tool Required		Not Provided	
2PERS	60MIN		

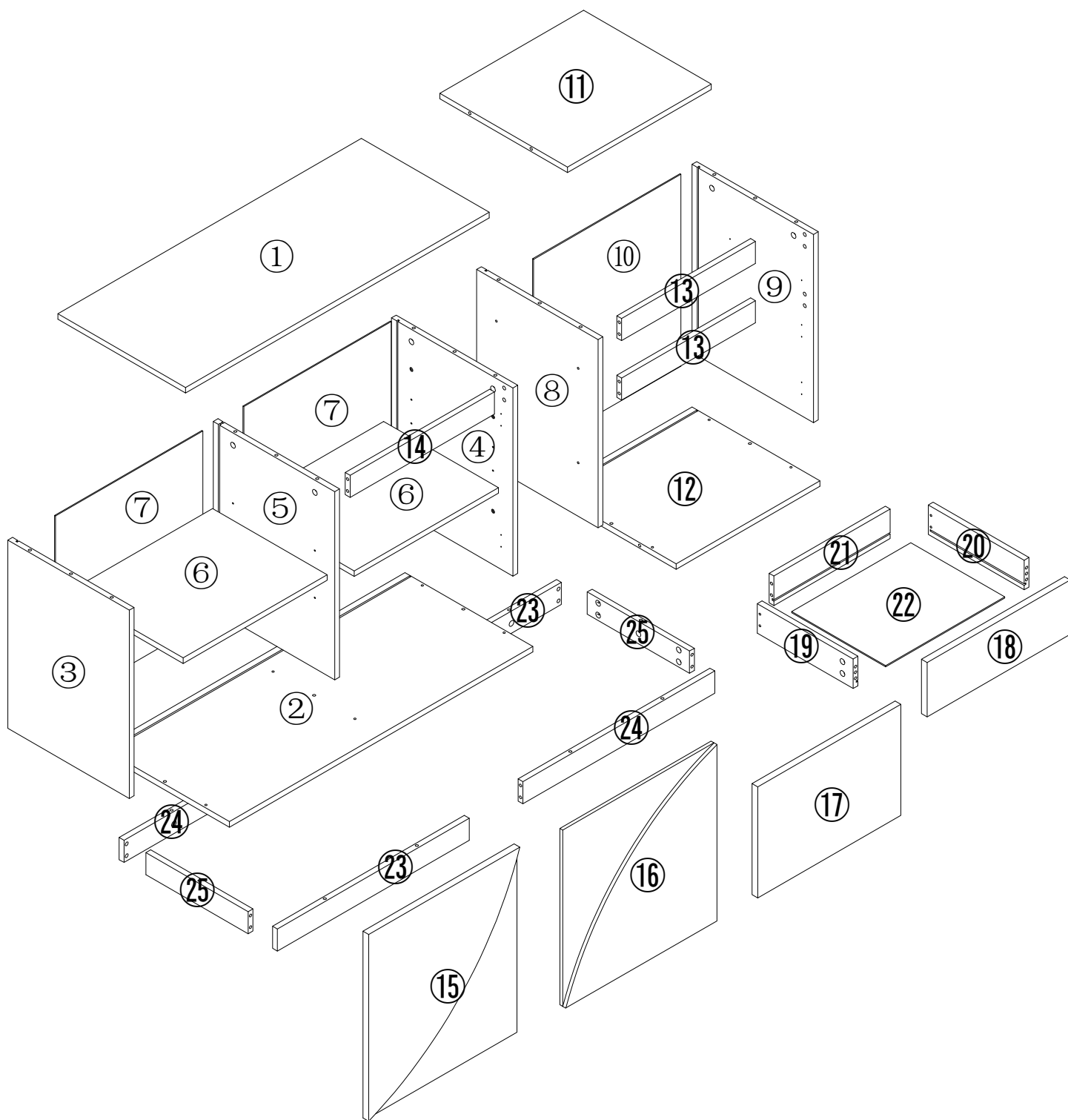



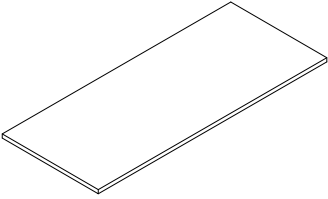
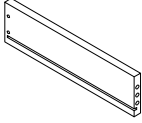
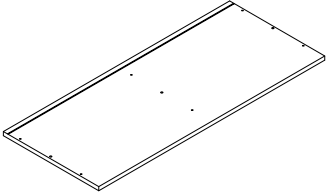
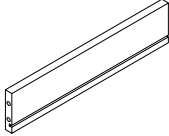
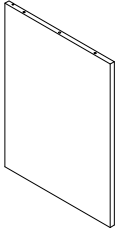
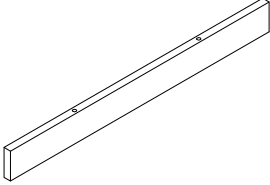
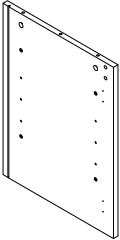
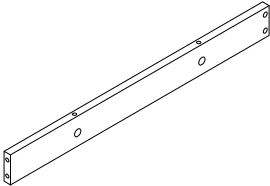
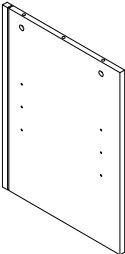
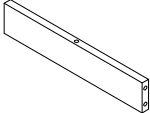
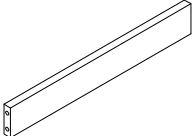
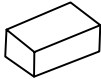
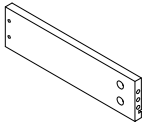

# N625P337264

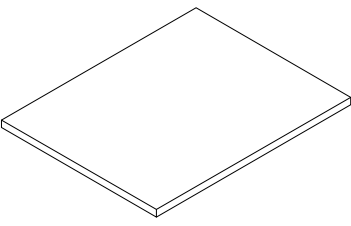
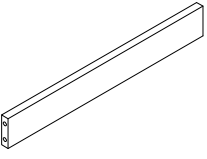
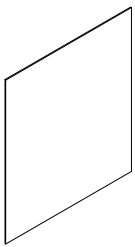
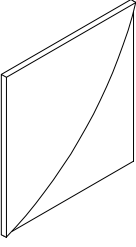
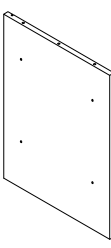
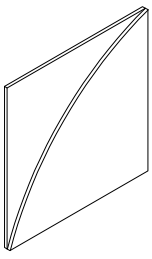
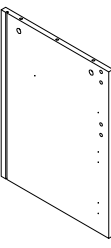
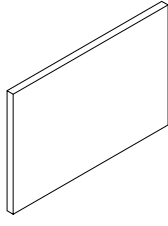
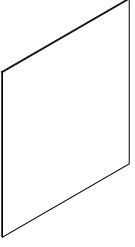
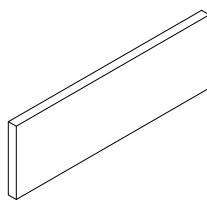
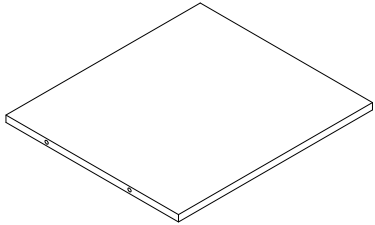
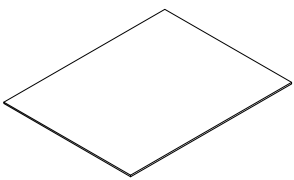
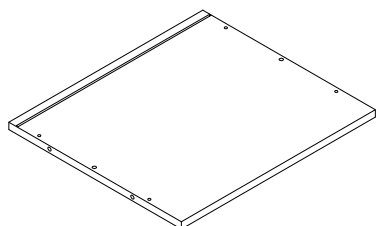
NO.	QTY	NO.	QTY
①		②①	
	1PC		1PC
②		②②	
	1PC		1PC
③		②③	
	1PC		2PCS
④		②④	
	1PC		2PCS
⑤		②⑤	
	1PC		2PCS
⑬		Hardware 	
	2PCS		
⑲			
	1PC		

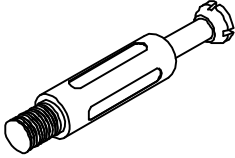
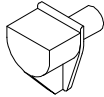
# N625P337265

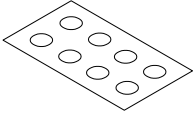
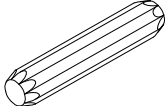
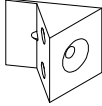
NO.	QTY	NO.	QTY
⑥	 2PCS	⑭	 1PC
⑦	 2PCS	⑮	 1PC
⑧	 1PC	⑯	 1PC
⑨	 1PC	⑰	 1PC
⑩	 1PC	⑱	 1PC
⑪	 1PC	⑳	 1PC
⑫	 1PC		

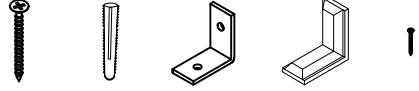
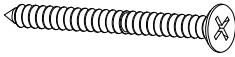
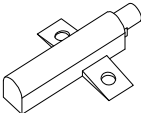
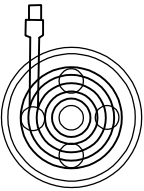
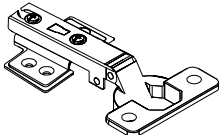
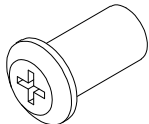
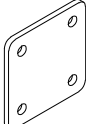
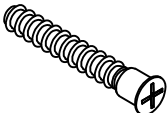
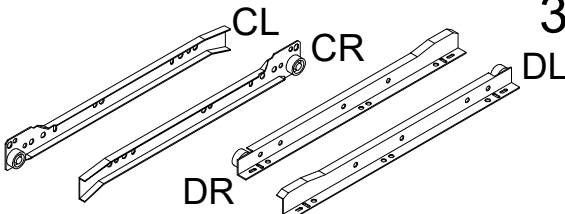
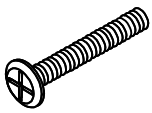
<p><b>A</b></p>  <p>50PCS</p>	<p><b>K</b></p>  <p>8PCS</p>
<p><b>B</b></p>  <p>50PCS</p>	<p><b>L</b></p>  <p>8PCS</p>
<p><b>C</b></p>  <p>20PCS</p>	<p><b>M</b></p>  <p>12PCS</p>
<p><b>D</b></p>  <p>66PCS</p>	<p><b>N</b></p>  <p>N1 N2 N3 N4 N5</p> <p>2SET</p>
<p><b>E</b></p>  <p>4PCS</p>	<p><b>P</b></p>  <p>1PC</p>
<p><b>F</b></p>  <p>1SET</p>	<p><b>Q</b></p>  <p>6PCS</p>
<p><b>G</b></p>  <p>4PCS</p>	<p><b>R</b></p>  <p>2PCS</p>
<p><b>H</b></p>  <p>10PCS</p>	<p><b>CL</b> <b>CR</b> <b>DL</b> <b>DR</b></p>  <p>300mm</p> <p>1SET</p>
<p><b>J</b></p>  <p>4PCS</p>	



[DE]

**Warnung:** Lesen Sie diese Anleitung vor dem Zusammenbau bitte vollständig durch. Überprüfen Sie, ob Sie alle auf den Seiten aufgeführten Komponenten und Werkzeuge haben. Bewahren Sie die Anleitung zum späteren Nachschlagen auf. Teile des Zusammenbaus lassen sich mit 2 Personen leichter durchführen. Suchen Sie bei Bedarf professionelle Hilfe.

**Warnung:** Legen Sie alle Teile auf eine ebene Fläche. Legen Sie eine weiche Decke oder Ähnliches darunter, um sie vor Kratzern oder Flecken zu schützen. Vermeiden Sie es, Komponenten über den Boden zu ziehen oder zu schieben.

**Warnung:** Überprüfen Sie regelmäßig alle Beschläge und Befestigungen, um sicherzustellen, dass sie sicher sind und um Unfälle zu vermeiden. Wenn Teile fehlen, kaputt, beschädigt oder abgenutzt sind, verwenden Sie das Produkt nicht weiter, bis es mit vom Hersteller autorisierten Teilen repariert wurde.

**Warnung:** Lassen Sie Kinder nicht auf die Möbel klettern, da dies zum Umkippen und zu schweren Verletzungen führen kann. Bauen Sie die Möbel außerhalb der Reichweite von Kindern zusammen.

**Warnung:** Stellen Sie die Möbel nicht in die Nähe von Feuerquellen oder heißen Gegenständen, um Brandgefahr zu vermeiden.

**Warnung:** Reinigen Sie die Möbel mit einem feuchten Tuch oder Alkohol. Verwenden Sie keine Reinigungsmittel mit ätzenden Chemikalien.

**Warnung:** Dieses Produkt ist mit einer Kippschutzvorrichtung ausgestattet. Bitte installieren Sie diese Vorrichtung unbedingt, um unnötige Verletzungen durch Umkippen zu vermeiden.

[EN]

**Warning:** Please read these instructions fully before starting assembly. Check you have all the components and tools listed on pages. Keep the instructions for later reference. Parts of the assembly will be easier with 2 people. Seek professional assistance if necessary.

**Warning:** Please place all parts on a flat surface. Place a soft blanket or similar underneath to protect against scratches or stains. Avoid dragging or sliding components across the floor.

**Warning:** Regularly check all fittings and fastenings to ensure they are secure and to prevent accidents. If any parts are missing, broken, damaged, or worn, discontinue use of the product until repairs have been made using factory authorized parts.

**Warning:** Do not allow children to climb on the furniture as this may result in tipping and serious personal injury. Assemble the furniture away from the reach of children.

**Warning:** Do not place furniture close to fire sources or high-temperature objects to avoid the risk of fire. Do not place furniture in damp environments to prevent material damage.

**Warning:** Clean furniture with a damp cloth or alcohol, avoid using cleaning agents containing corrosive chemicals.

**Warning:** This product is equipped with an anti-tilt device. Please be sure to install this device to prevent unnecessary injuries caused by tipping.

[FR]

**Avertissement :** Veuillez lire attentivement ces instructions avant de commencer l'assemblage. Vérifiez que vous disposez de tous les composants et outils répertoriés sur les pages. Conservez les instructions pour référence ultérieure. Certaines parties de l'assemblage seront plus faciles à 2 personnes. Demandez l'aide d'un professionnel si nécessaire.

**Avertissement :** Veuillez placer toutes les pièces sur une surface plane. Placez une couverture douce ou similaire en dessous pour les protéger des rayures ou des taches. Évitez de faire glisser les composants sur le sol.

**Avertissement :** Vérifiez régulièrement tous les raccords et fixations pour vous assurer qu'ils sont bien fixés et

pour éviter les accidents. Si des pièces manquent, sont cassées, endommagées ou usées, cessez d'utiliser le produit jusqu'à ce que des réparations aient été effectuées à l'aide de pièces autorisées par l'usine.

**Avertissement** : Ne laissez pas les enfants grimper sur les meubles car cela pourrait entraîner un basculement et des blessures graves. Assemblez les meubles hors de portée des enfants.

**Avertissement** : Ne placez pas les meubles à proximité de sources de feu ou d'objets à haute température pour éviter tout risque d'incendie.

**Avertissement** : Nettoyez les meubles avec un chiffon humide ou de l'alcool, évitez d'utiliser des produits de nettoyage contenant des produits chimiques corrosifs.

**Avertissement** : Ce produit est équipé d'un dispositif anti-basculement. Assurez-vous d'installer ce dispositif pour éviter les blessures inutiles causées par un basculement.

[IT]

**Attenzione**: leggere attentamente queste istruzioni prima di iniziare il montaggio. Verificare di avere tutti i componenti e gli strumenti elencati nelle pagine. Conservare le istruzioni per riferimento futuro. Alcune parti del montaggio saranno più facili con 2 persone. Se necessario, chiedere assistenza professionale.

**Attenzione**: posizionare tutte le parti su una superficie piana. Posizionare una coperta morbida o simile sotto per proteggere da graffi o macchie. Evitare di trascinare o far scivolare i componenti sul pavimento.

**Attenzione**: controllare regolarmente tutti i raccordi e i dispositivi di fissaggio per assicurarsi che siano sicuri e per prevenire incidenti. Se alcune parti sono mancanti, rotte, danneggiate o usurate, interrompere l'uso del prodotto fino a quando non siano state eseguite le riparazioni utilizzando parti autorizzate dalla fabbrica.

**Attenzione**: non consentire ai bambini di arrampicarsi sui mobili poiché ciò potrebbe causare ribaltamenti e gravi lesioni personali. Montare i mobili lontano dalla portata dei bambini.

**Attenzione**: non posizionare i mobili vicino a fonti di fuoco o oggetti ad alta temperatura per evitare il rischio di incendio

**Attenzione**: pulire i mobili con un panno umido o alcol, evitare di utilizzare detergenti contenenti sostanze chimiche corrosive.

**Attenzione**: questo prodotto è dotato di un dispositivo antiribaltamento. Assicurarsi di installare questo dispositivo per prevenire lesioni inutili causate dal ribaltamento.

[ES]

**Advertencia**: Lea estas instrucciones completamente antes de comenzar el montaje. Compruebe que tiene todos los componentes y herramientas que se enumeran en las páginas. Conserve las instrucciones para consultarlas más adelante. El montaje de algunas partes será más sencillo con 2 personas. Busque ayuda profesional si es necesario.

**Advertencia**: Coloque todas las piezas sobre una superficie plana. Coloque una manta suave o algo similar debajo para protegerlas de rayones o manchas. Evite arrastrar o deslizar los componentes por el piso.

**Advertencia**: Verifique regularmente todos los accesorios y fijaciones para asegurarse de que estén seguros y evitar accidentes. Si falta alguna pieza, está rota, dañada o desgastada, deje de usar el producto hasta que se hayan realizado las reparaciones con piezas autorizadas de fábrica.

**Advertencia**: No permita que los niños se suban a los muebles, ya que esto puede provocar que se vuelquen y lesiones personales graves. Monte los muebles fuera del alcance de los niños.

**Advertencia**: No coloque los muebles cerca de fuentes de fuego u objetos de alta temperatura para evitar el riesgo de incendio.

**Advertencia**: Limpie los muebles con un paño húmedo o alcohol, evite usar agentes de limpieza que contengan químicos corrosivos.

**Advertencia**: Este producto está equipado con un dispositivo antivuelco. Asegúrese de instalar este dispositivo para evitar lesiones innecesarias causadas por vuelcos.

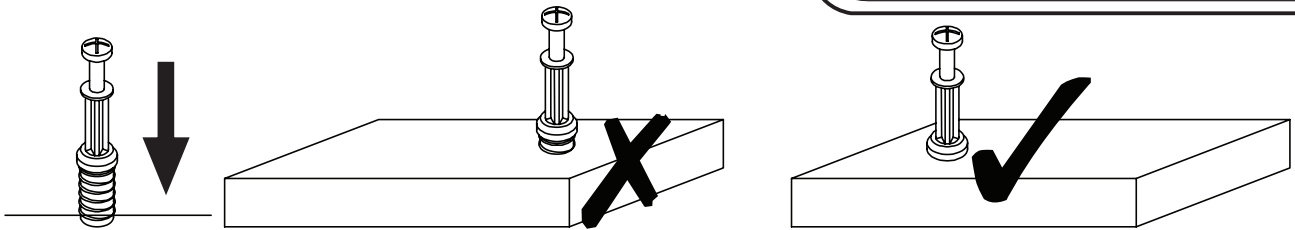

**EN\_QUICKFIT:** Tighten quickfit until shoulder is flush with panel. Do not overtighten or undertighten.

**FR\_RACCORD RAPIDE:** Faites serrer le raccord rapide jusqu'à ce que l'épaulement soit parfaitement encastré dans le panneau. Il ne faut ni trop serrer ni insuffisamment serrer.

**ES\_QUICKFIT:** Apriete quickfit hasta que el hombro se descargue con el panel. NO lo sobreapriete ni lo apriete poco.

**DE\_QUICKFIT:** Ziehen Sie den Quickfit fest, bis die Schulter mit der Platte bündig ist. Bitte nicht zu fest oder zu schwach anziehen.

**IT\_MONTAGGIO RAPIDO:** Stringere il montaggio rapido fino a quando la spalla è a filo con il pannello, non stringere troppo o troppo poco.

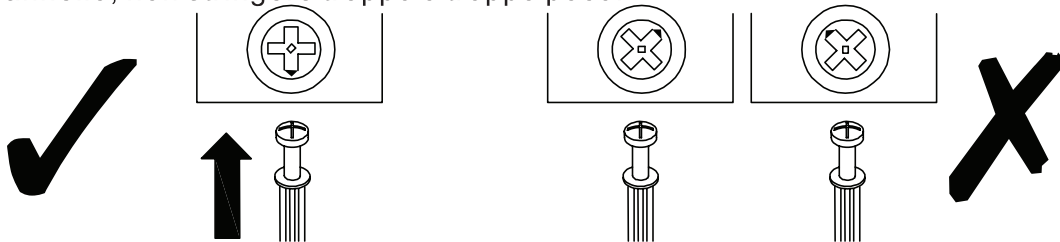

**EN\_CAM LOCK:** When fitting cam lock, ensure starting position is correct before you insert connecting quickfit.

**FR\_SERRURE BATTEUSE:** Avant d'insérer la serrure batteuse, veillez à la bonne orientation avant d'insérer le raccord rapide.

**ES\_CIERRE DE LA CÁMARA:** Cuando instale el cierre de la cámara, asegúrese de que la posición de inicio es correcta antes de que inserte el quickfit conector.

**DE\_CAM-LOCK:** Achten Sie bei der Montage des Cam-Locks auf die richtige Ausgangsposition, bevor Sie den Quickfit einsetzen.

**IT\_BLOCCAGGIO A CAMMA:** Quando si monta il bloccaggio a camma, assicurarsi che la posizione iniziale sia corretta prima di inserire il montaggio rapido di collegamento.

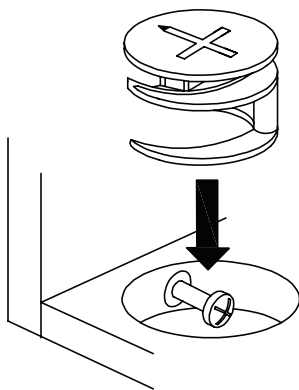

**EN\_Quickfit head** should be in the centre of the cam lock when the two panels are joined.

Cam lock should be inserted before quickfit.

**FR\_Lorsque** les deux panneaux sont assemblés, la tête du raccord rapide doit reposer au centre de la serrure batteuse. Il faut insérer la serrure batteuse avant le raccord rapide.

**ES\_El** cabezal del quickfit debe estar en el centro del cierre de la cámara cuando se unan los dos paneles.

Se debe insertar el cierre de la cámara antes que el quickfit.

**DE\_Der** Quickfit-Kopf sollte sich in der Mitte des Cam-Locks befinden, wenn die beiden Platten zusammengefügt sind. Der Cam-Lock sollte vor dem Quickfit eingesetzt werden.

**IT\_La** testa del montaggio rapido deve trovarsi al centro del bloccaggio a camma quando i due pannelli sono uniti.

Il Bloccaggio a Camma deve essere inserito prima del montaggio rapido.

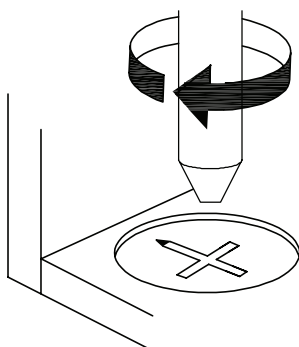

**EN\_Turn** cam lock clockwise to tighten.

**FR\_Faites** tourner la serrure batteuse dans le sens des aiguilles d'une montre pour la resserrer.

**ES\_Gire** el cierre de la cámara en sentido horario para apretarlo.

**DE\_Drehen** Sie den Cam-Lock im Uhrzeigersinn, um ihn festzuziehen.

**IT\_Ruotare** il bloccaggio a camma in senso orario per stringere.

EN\_It may be necessary to adjust the hinges so that the doors align. Use the instructions below as a guide.

FR\_Il est parfois nécessaire d'ajuster les charnières pour un meilleur alignement des portes. Servez-vous des instructions ci-dessous comme guide.

ES\_Puede que sea necesario ajustar los quicios de forma que se alineen las puertas. Use las instrucciones que aparecen debajo como guía.

DE\_Möglicherweise müssen Sie die Scharniere so einstellen, dass die Türen ausgerichtet sind. Verwenden Sie die nachstehenden Anweisungen als Leitfaden.

IT\_Potrebbe essere necessario regolare le cerniere in modo che le porte siano allineate. Per fare ciò attenersi alle istruzioni sottostanti.

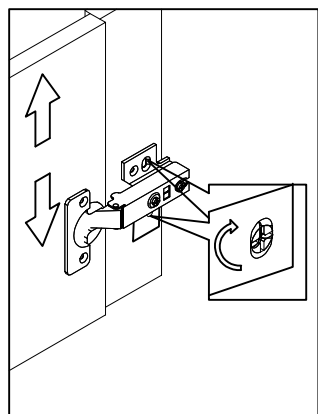

EN\_To adjust the door vertically loosen the screw as shown and move up and down as needed.

FR\_Si vous souhaitez régler la porte verticalement, desserrez la vis comme indiqué et déplacez la porte de haut en bas selon les besoins.

ES\_Para ajustar la puerta verticalmente afloje el tornillo tal y como se muestra y muévalo hacia arriba o hacia abajo según sea necesario.

DE\_Um die Tür vertikal auszurichten, lösen Sie die Schraube wie abgebildet und bewegen Sie sie nach Bedarf nach oben oder nach unten.

IT\_Per allineare la porta verticalmente allentare la vite come mostrato e spostarla in alto o in basso secondo necessità.

EN\_To adjust the gap from the door to the main frame turn the screw clockwise or anti-clockwise as needed.

FR\_Si vous souhaitez ajuster l'ecart entre la porte et le cadre principal, tournez la vis dans le sens des aiguilles d'une montre ou dans le sens inverse, si nécessaire.

ES\_Para ajustar el espacio desde la puerta al marco principal, gire el tornillo en sentido horario o antihorario según se necesite.

DE\_Um den Abstand von der Tür zum Hauptrahmen auszurichten, drehen Sie die Schraube je nach Bedarf im oder gegen den Uhrzeigersinn.

IT\_Per regolare lo spazio tra la porta e il telaio principale, avvitare o svitare la vite secondo necessità.

EN\_To adjust the door laterally adjust the screw as shown by turning clockwise or anti-clockwise.

FR\_Si vous souhaitez ajuster la porte latéralement, ajustez la vis comme indiqué en tournant dans le sens des aiguilles d'une montre ou dans le sens inverse des aiguilles d'une montre.

ES\_Para ajustar la puerta lateralmente ajuste el tornillo tal y como se muestra girándolo en sentido horario y antihorario.

DE\_Um die Tür seitlich auszurichten, stellen Sie bitte die Schraube wie abgebildet durch Drehen im oder gegen den Uhrzeigersinn ein.

IT\_Per allineare la porta lateralmente regolare la vite come mostrato, avvitandola o svitandola

EN\_Please fix other screws

FR\_Merci de serrer les autres vis

ES\_Fije los demás tornillos

DE\_Befestigen Sie bitte die anderen Schrauben IT\_Fissare le altre viti

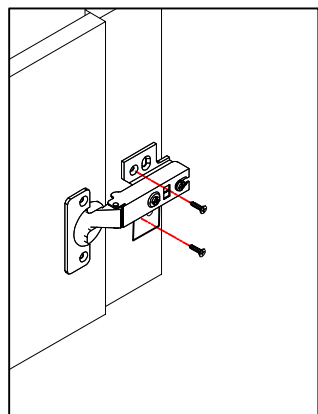

1

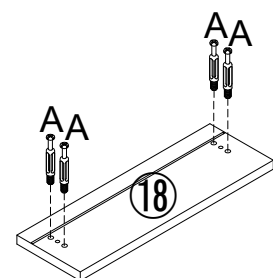
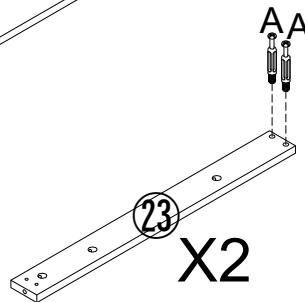
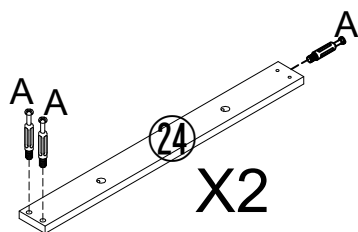
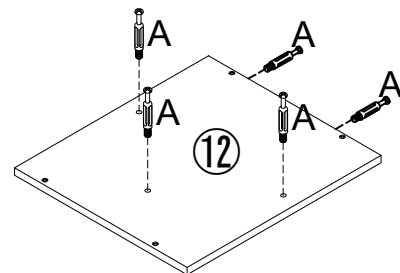
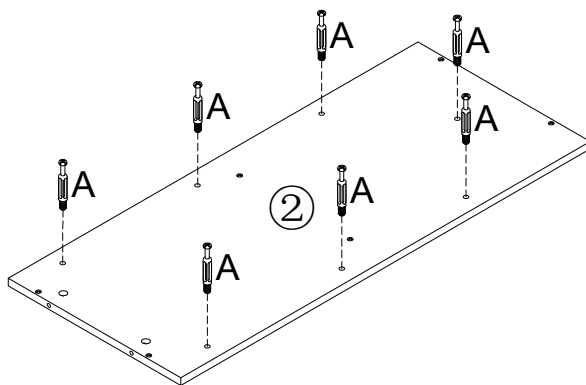
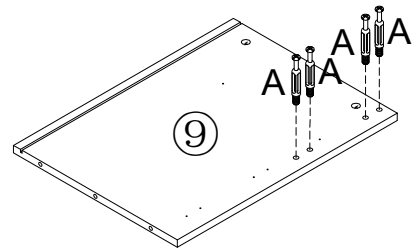
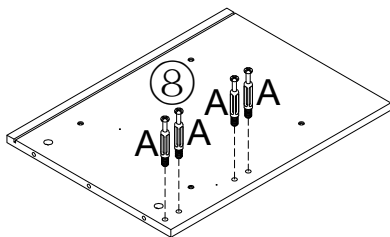
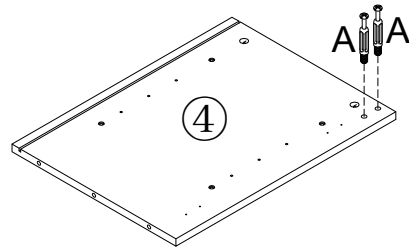
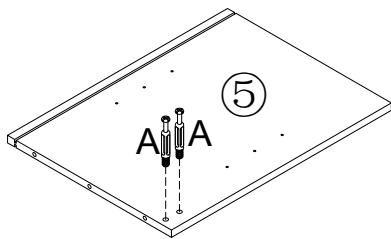
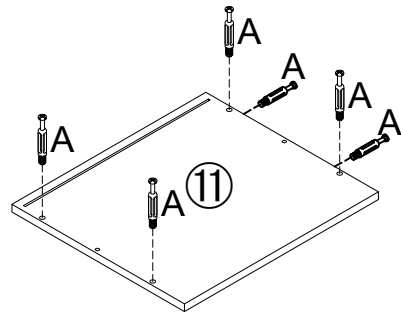
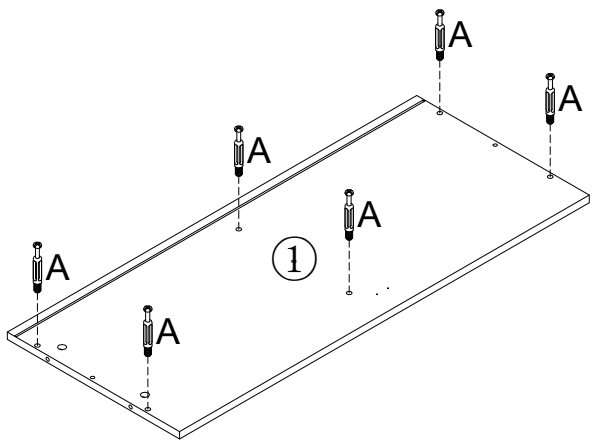
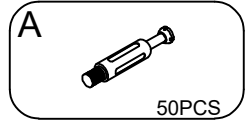

2

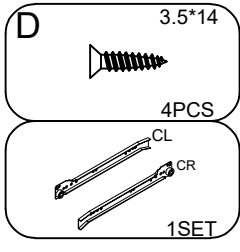
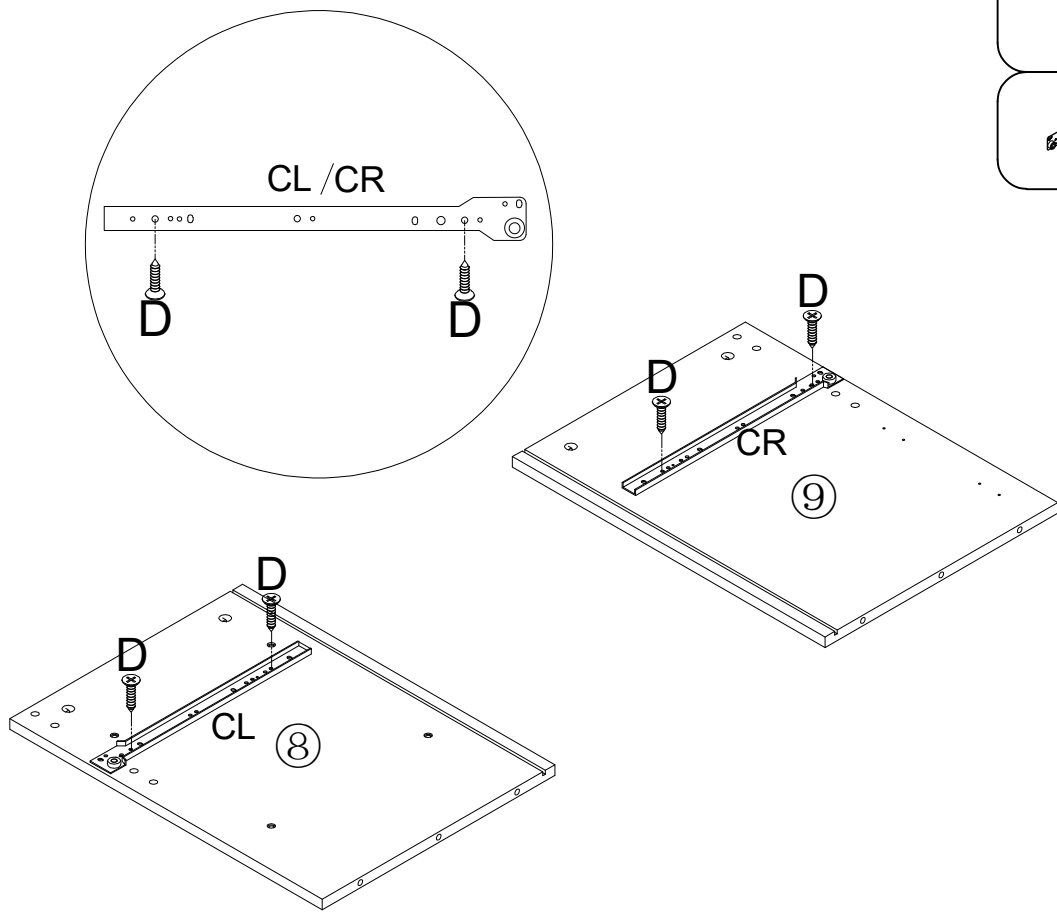

3

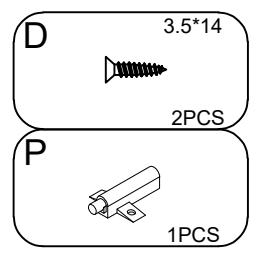
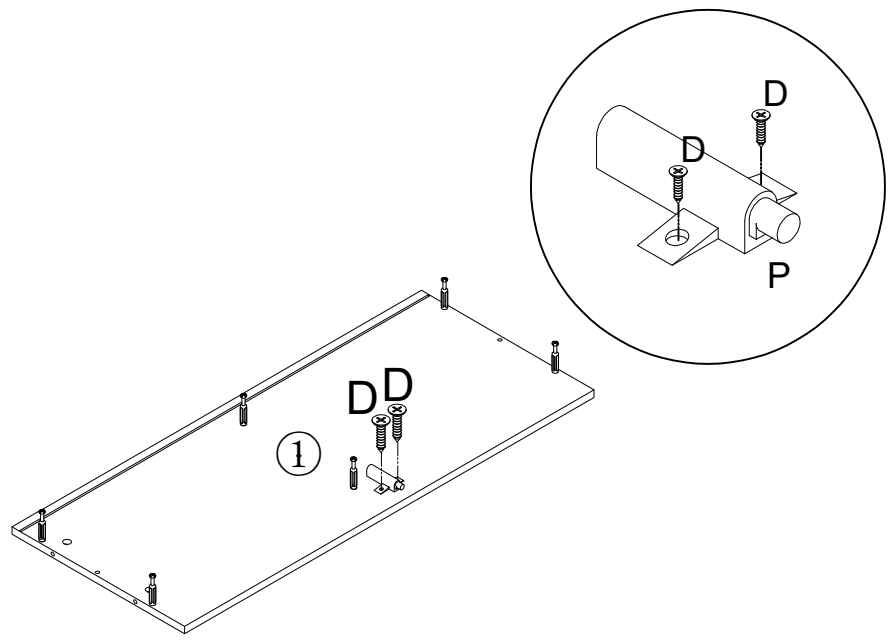

4

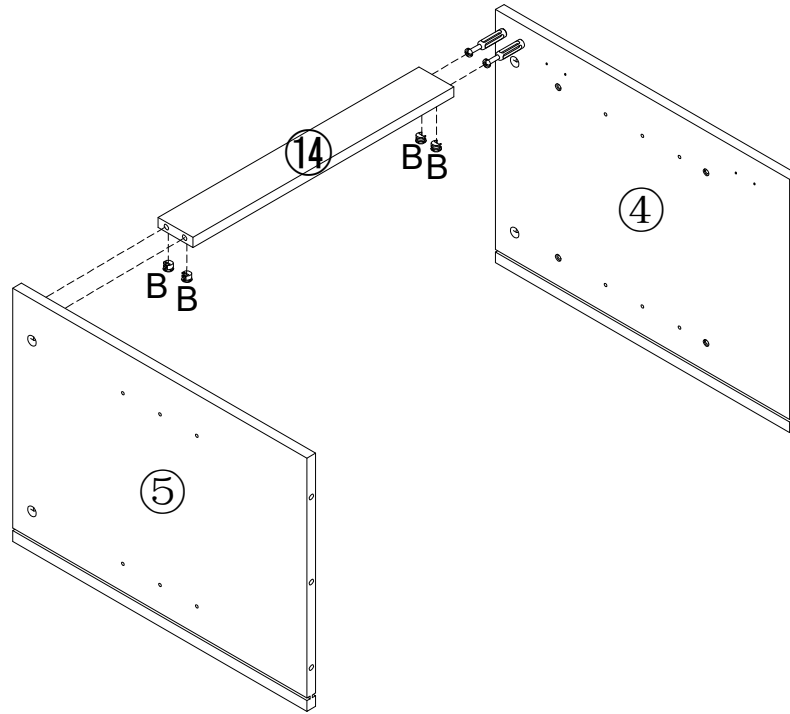
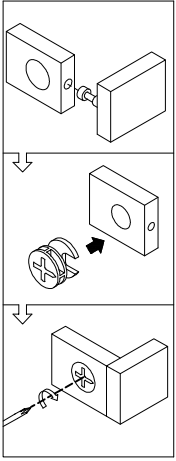
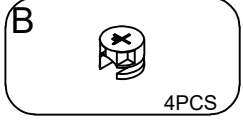

5

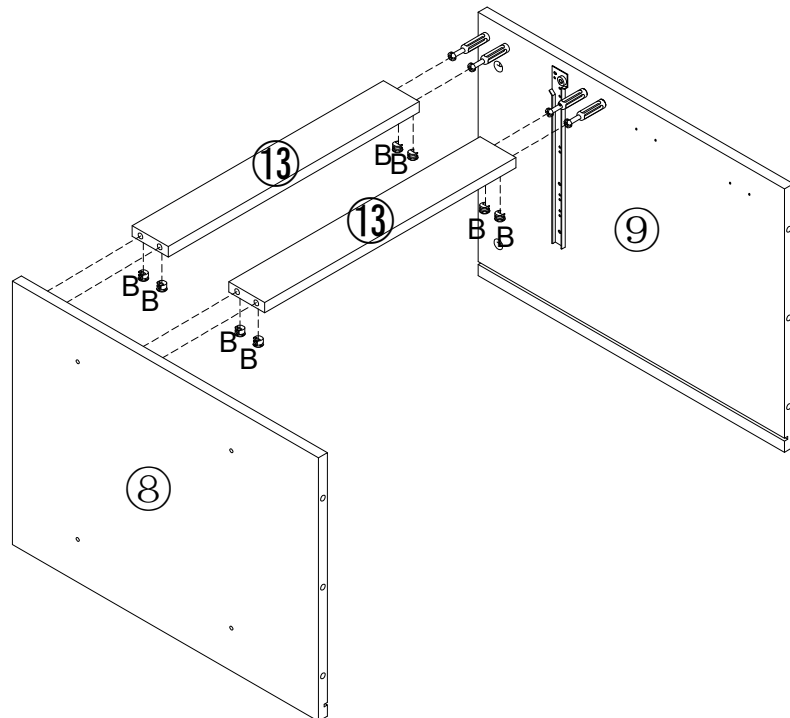
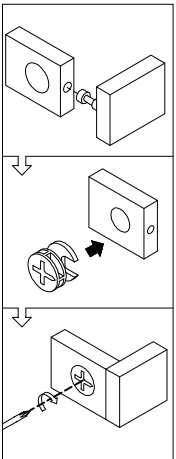
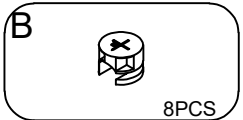

6

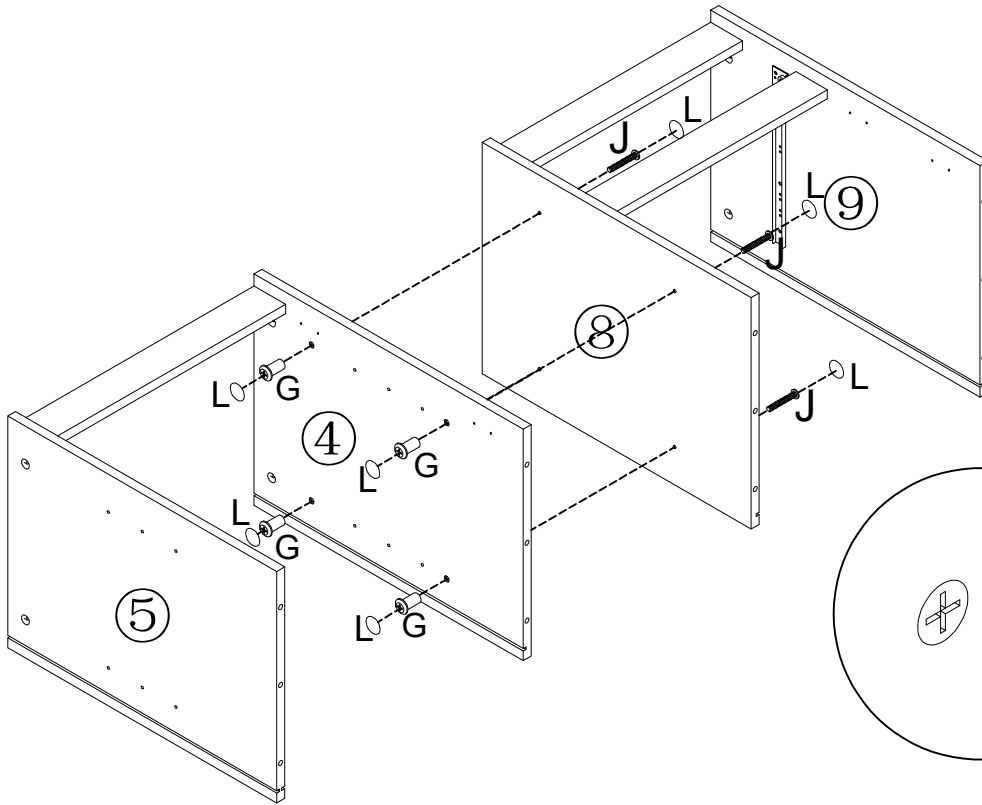

- G 4PCS  
6\*20
- J 4PCS
- L 8PCS

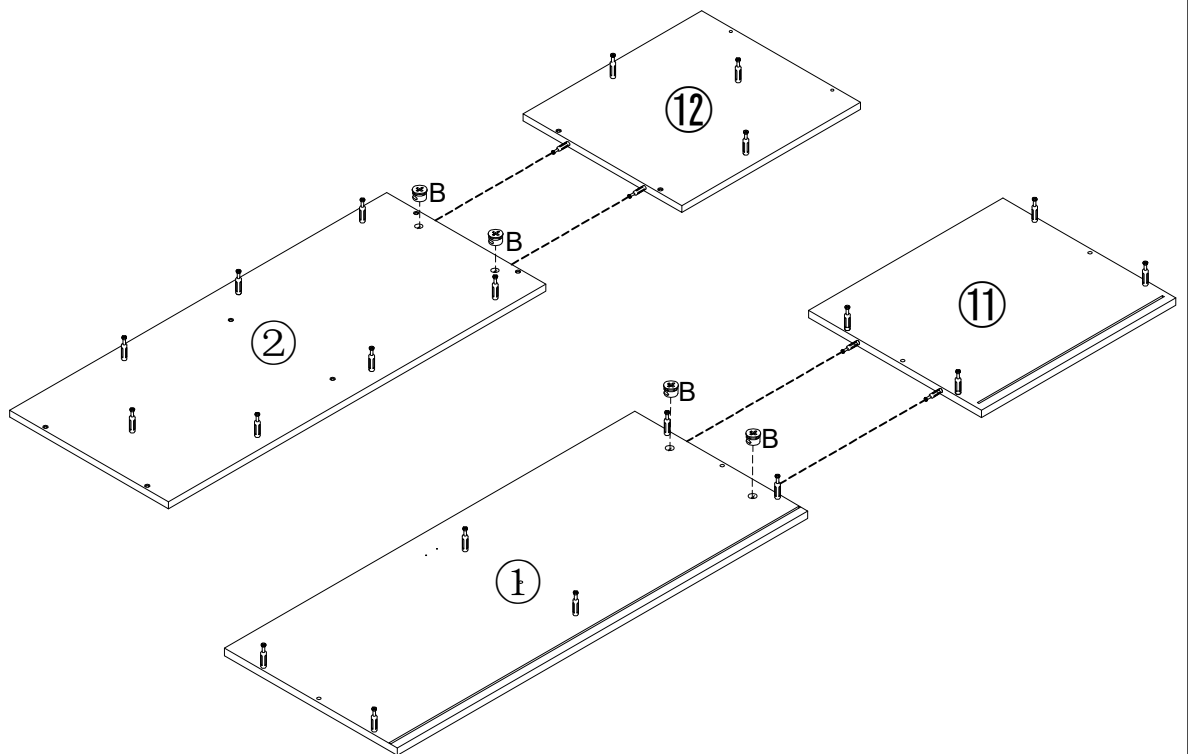
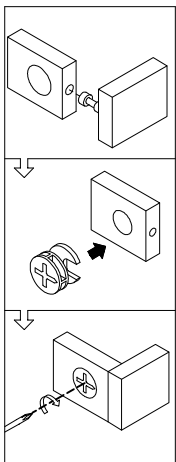

7



- B 4PCS

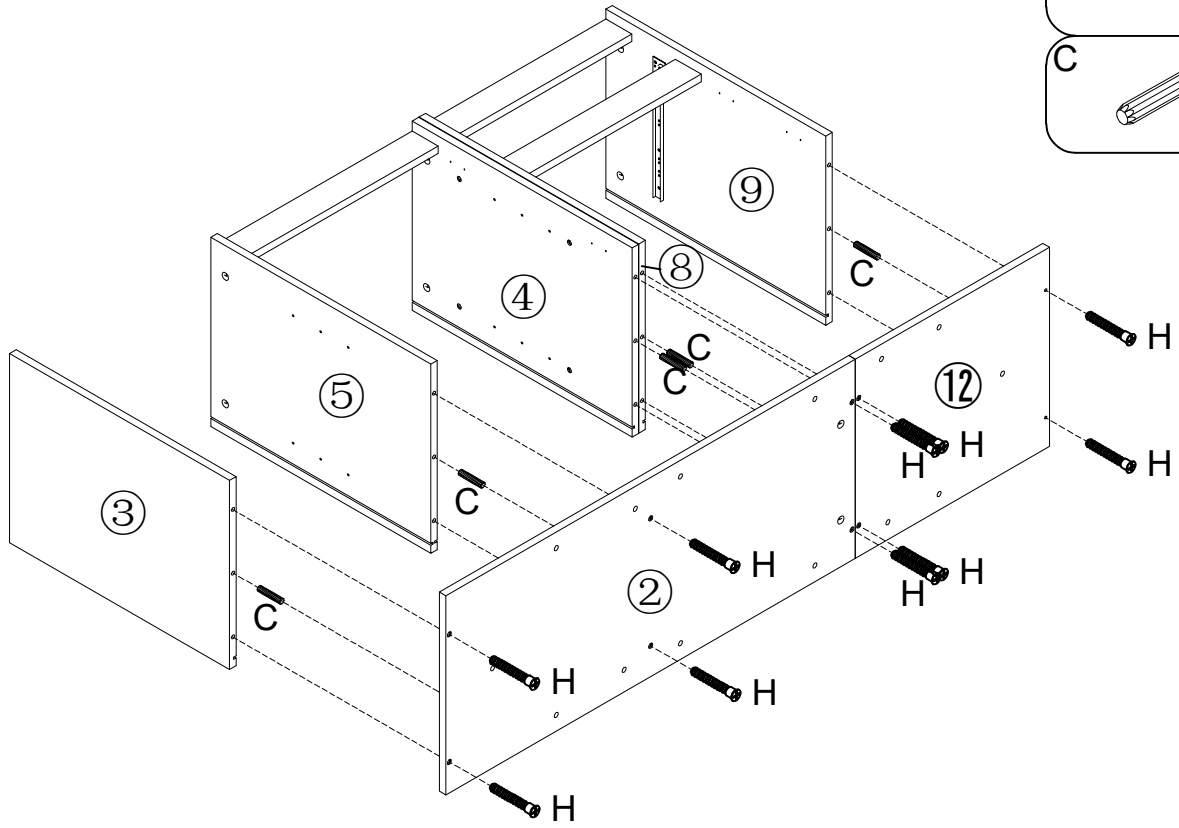



8

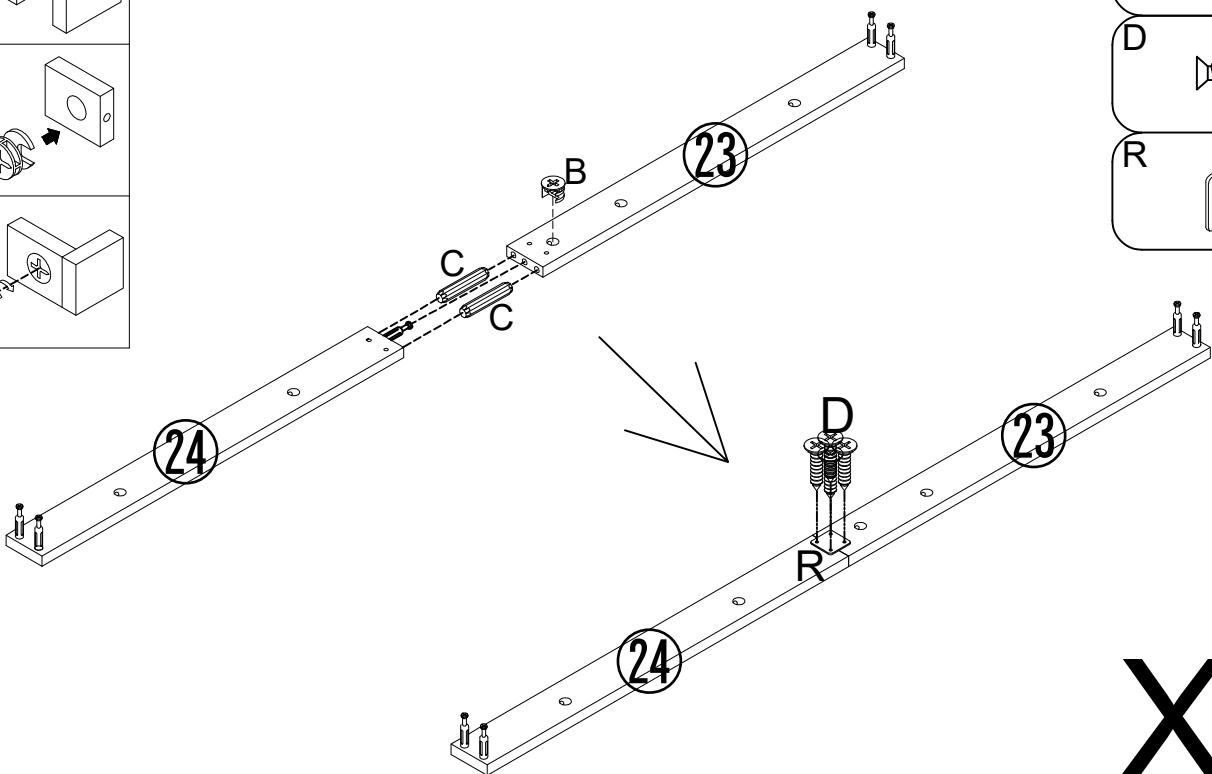
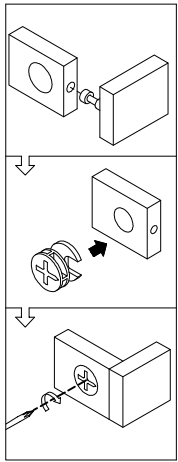

- H  10PCS  
8\*40
- C  5PCS

9



- B  2PCS  
8\*40
- C  4PCS  
3.5\*14
- D  8PCS
- R  2PCS

X2

10

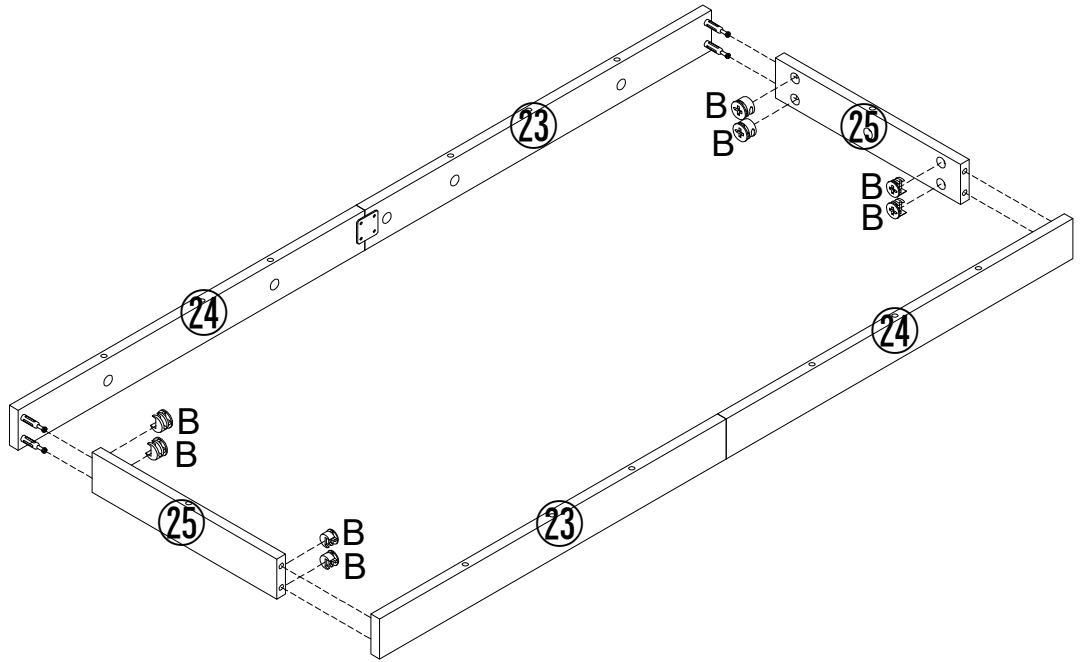
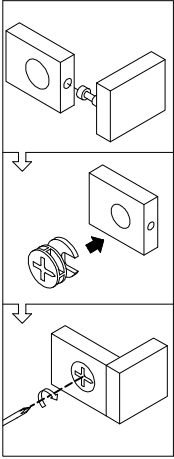

11

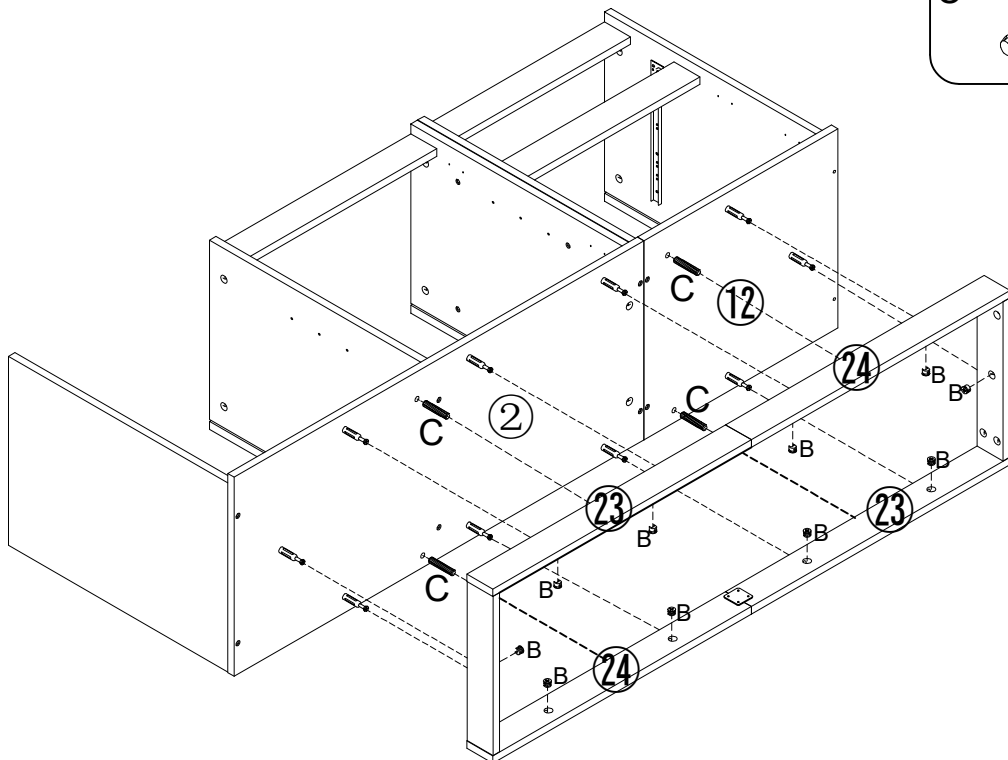
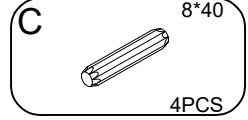
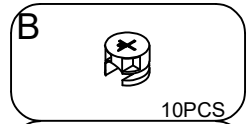
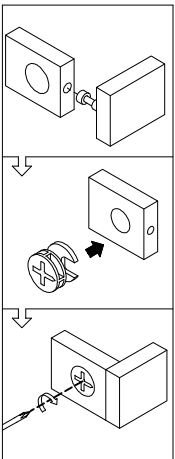

12

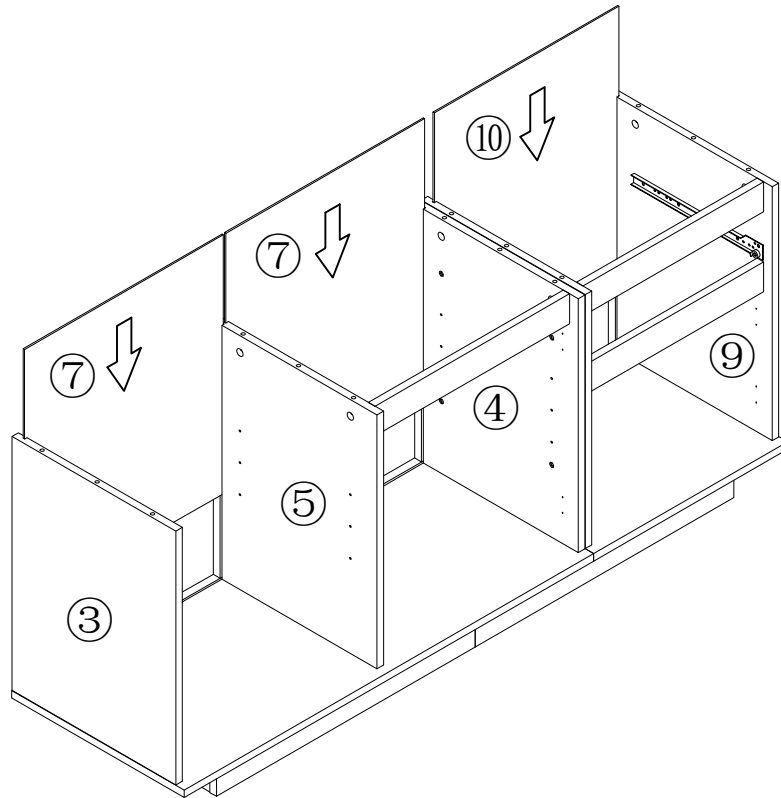

13

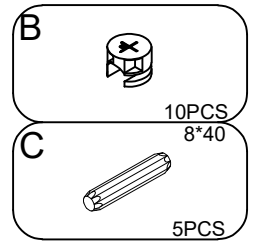
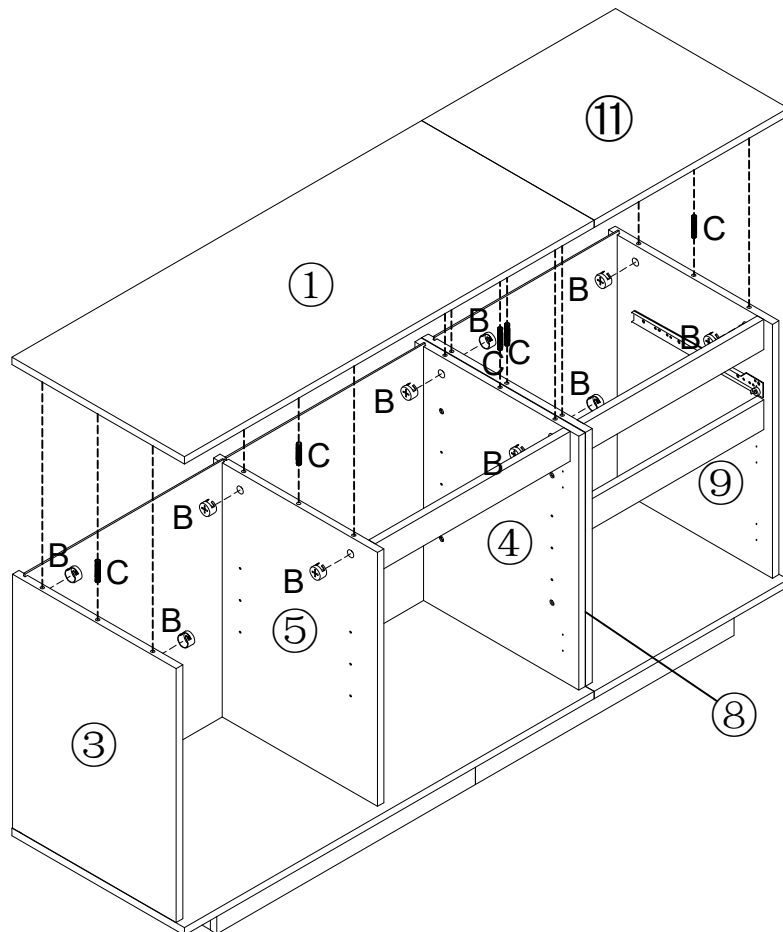

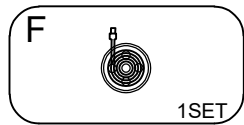

DE: Reißen Sie den blauen Aufkleber auf der Rückseite des Lichtstreifens ab und platzieren Sie den LED-Lichtstreifen an der Unterseite der Platine ① ①①

EN: Tear off the blue sticker on the back of the light strip and place the LED light strip at the bottom of the board ① ①①

FR: Détachez l'autocollant bleu au dos de la bande lumineuse et placez la bande lumineuse LED au bas de la carte ① ①①

IT: Staccare l'adesivo blu sul retro della striscia luminosa e posizionare la striscia luminosa a LED nella parte inferiore della scheda ① ①①

ES: Quite la etiqueta azul de la parte posterior de la tira de luz y coloque la tira de luz LED en la parte inferior del tablero ① ①①

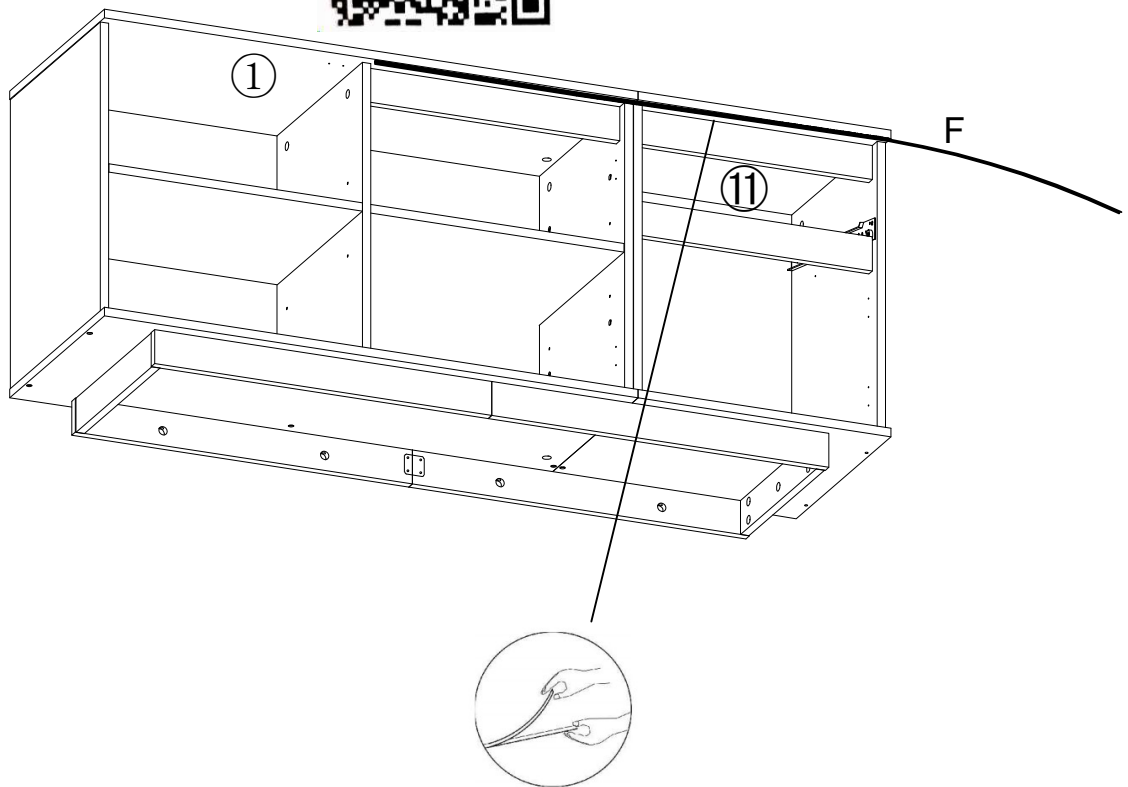

EN: Scan to download App control the Led light.

DE: Scannen, um die App zum Steuern des LED-Lichts herunterzuladen





FR: Scanner pour télécharger App contrôler la lumière Led.

ES: Analice para descargar la aplicación control de la luz Led.

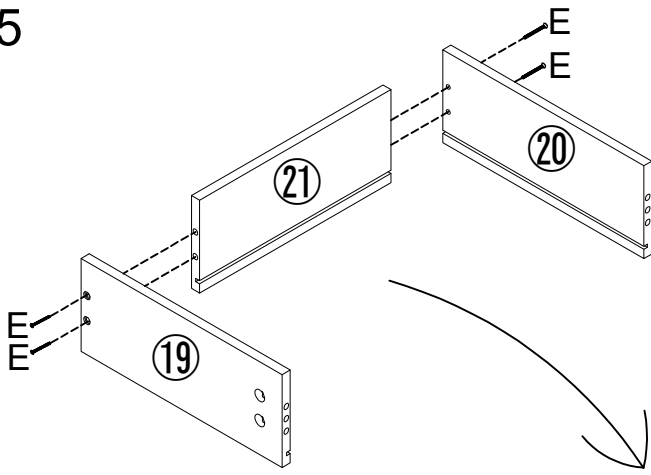
IT: Scansiona per scaricare l'applicazione controlla la luce Led.

15



- B**  4PCS  
8\*40
- C**  2PCS  
3.5\*14
- D**  4PCS  
3.5\*35
- E**  4PCS

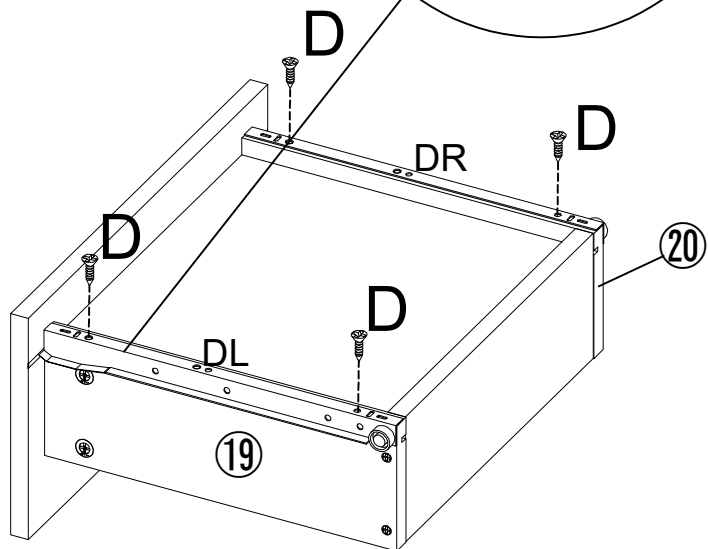
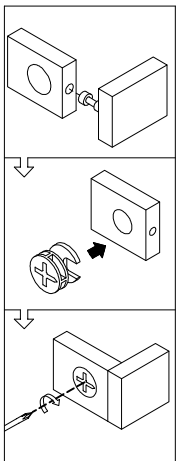
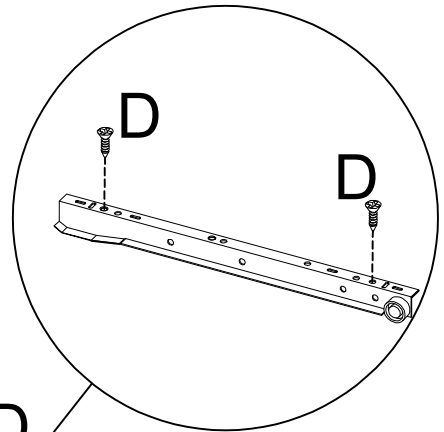
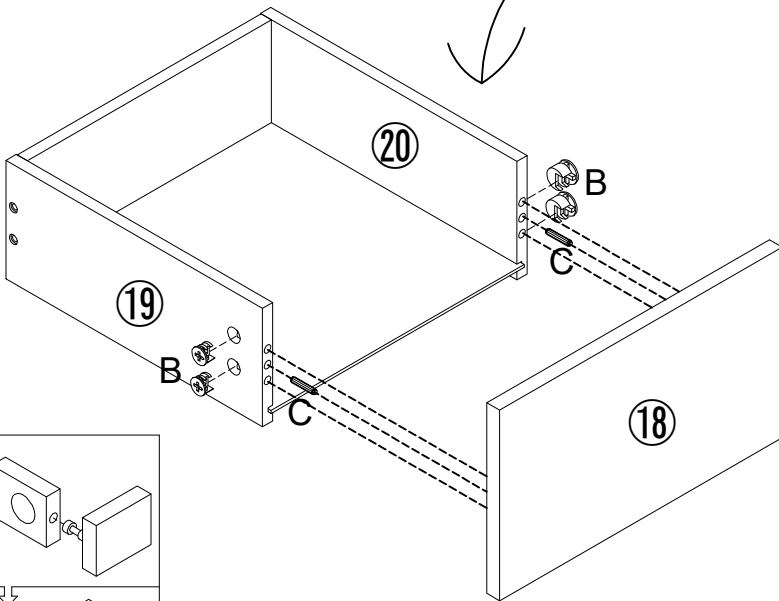
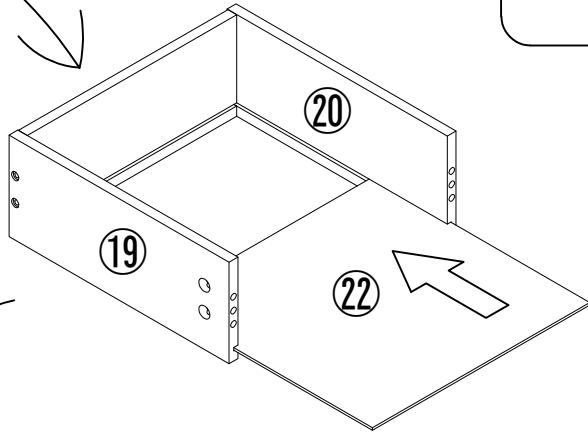

16

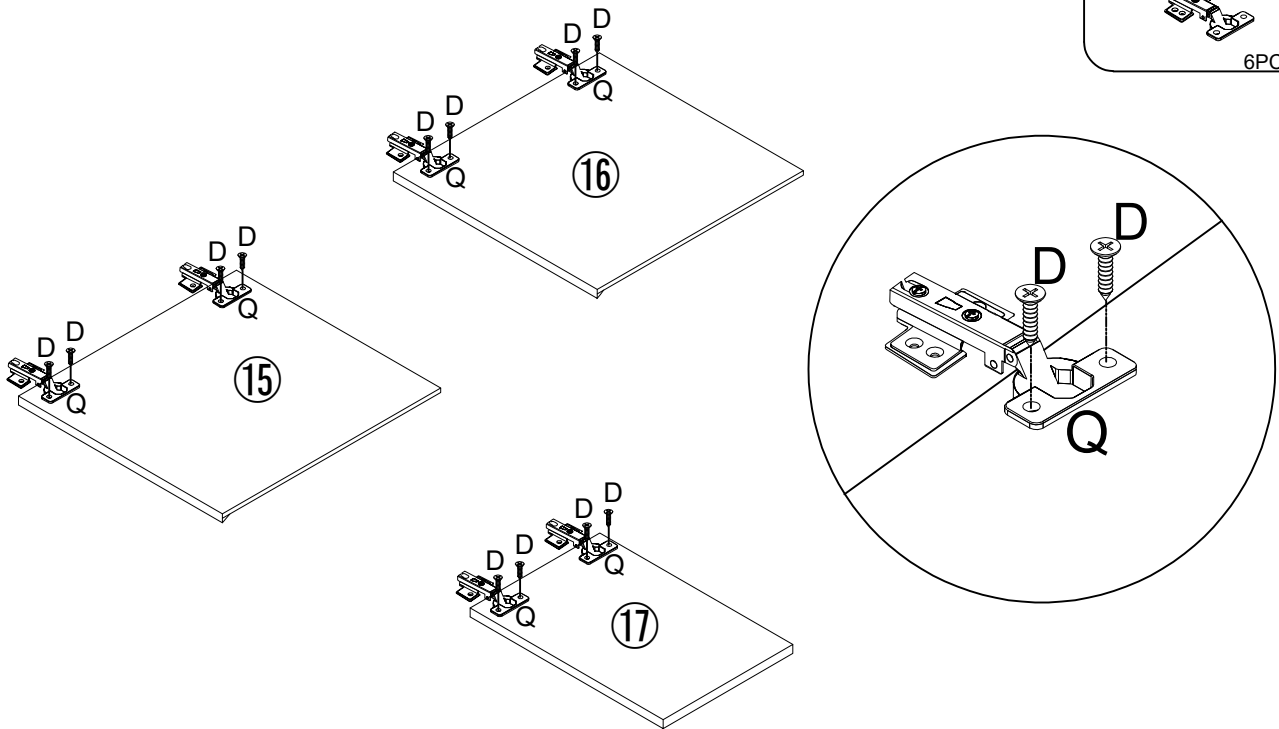
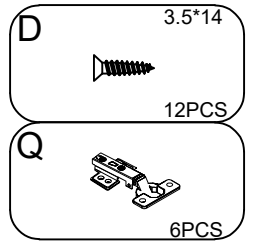

17

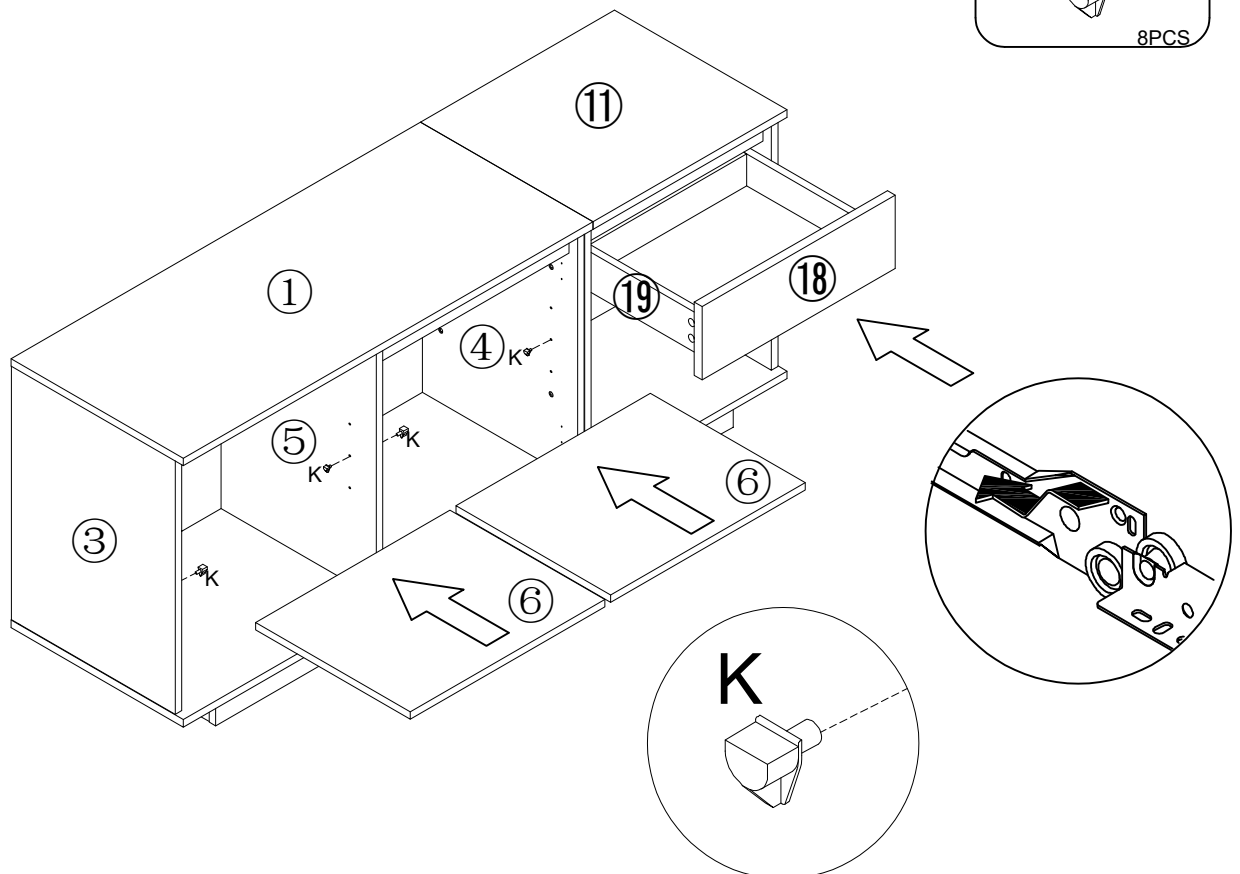
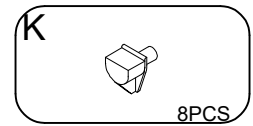

18

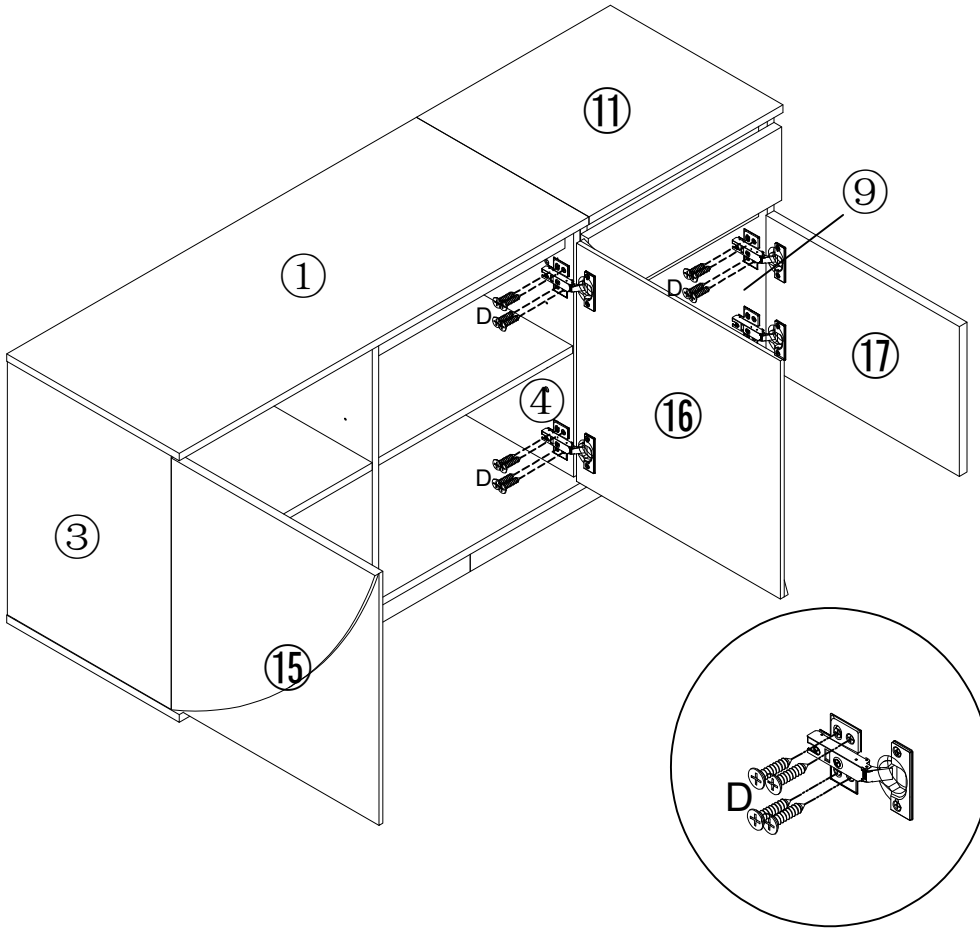
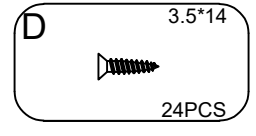

19

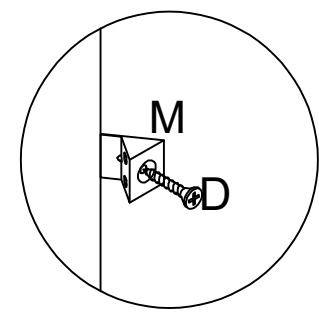
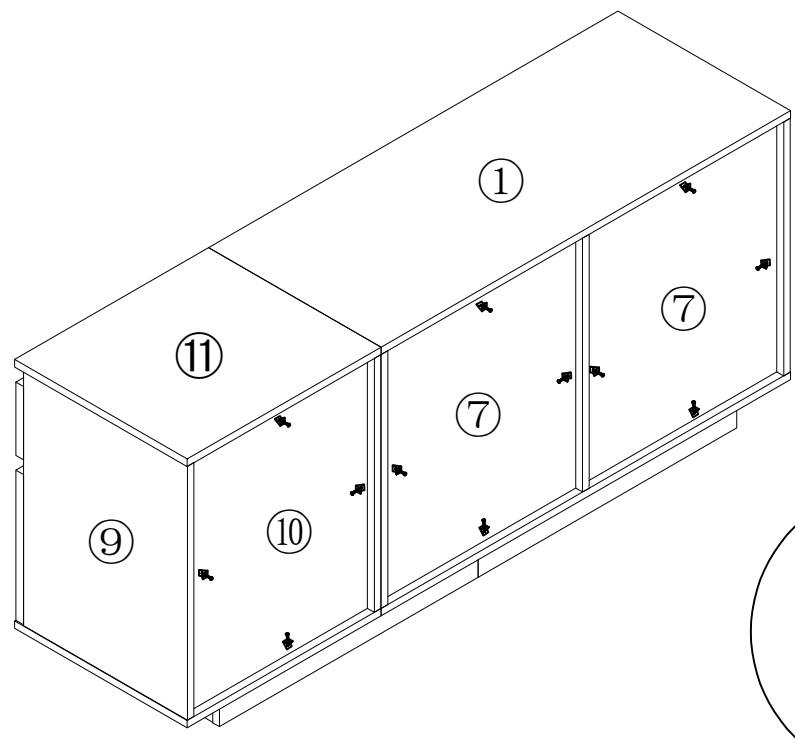
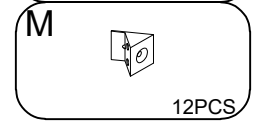
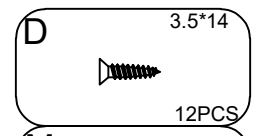

20

N  
N1 N2 N3 N4 N5  
2SET

Wall  
Wand  
Parete  
Mur  
Pared

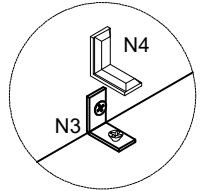
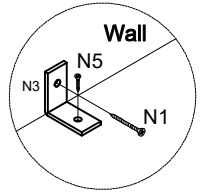
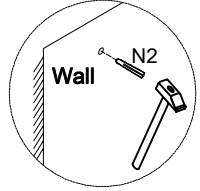
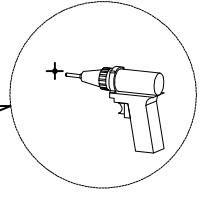
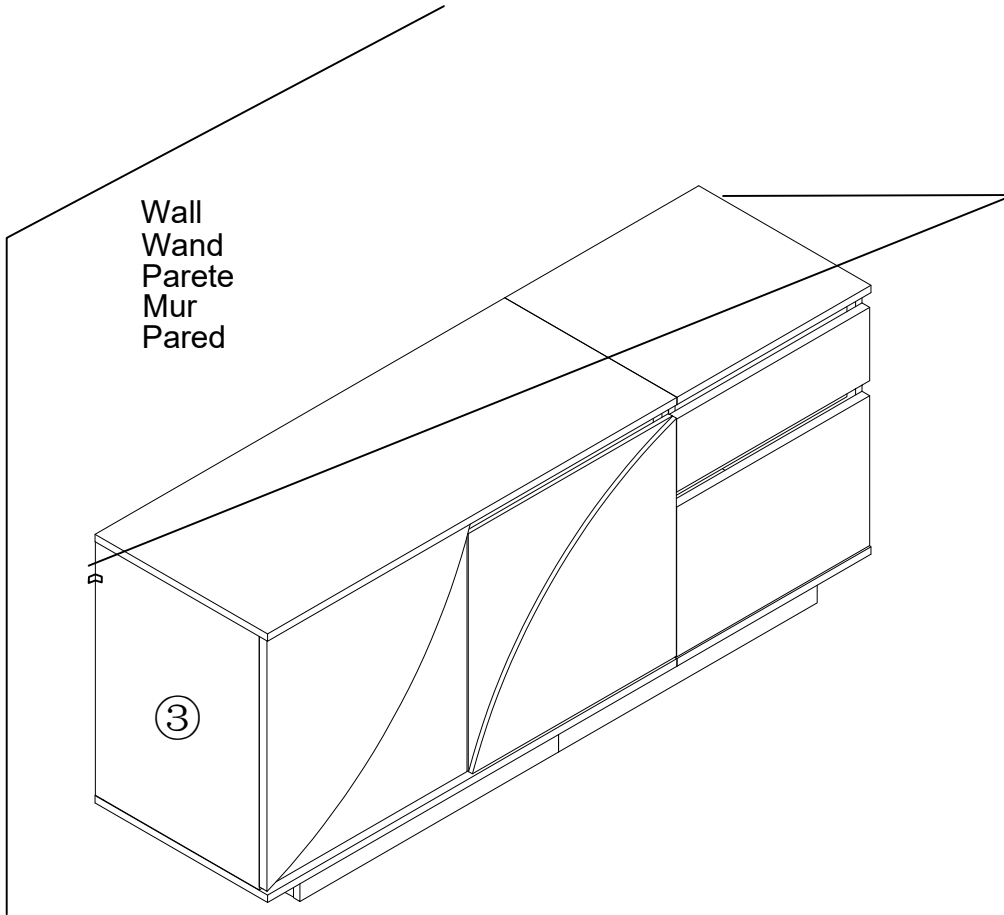

21

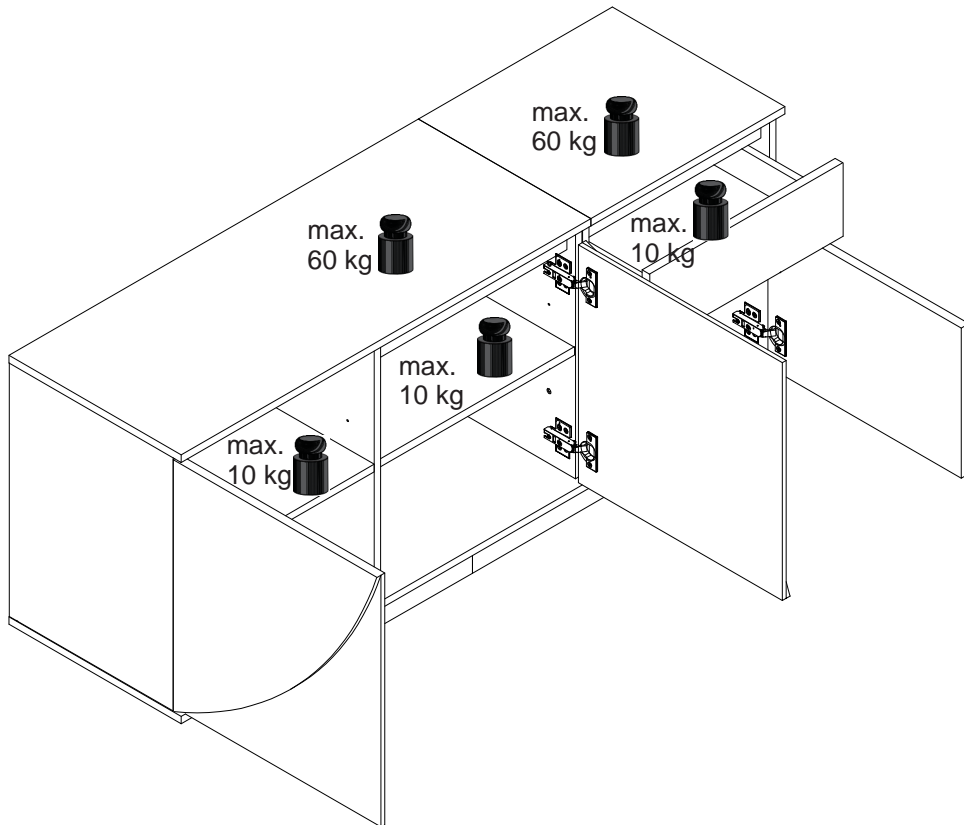

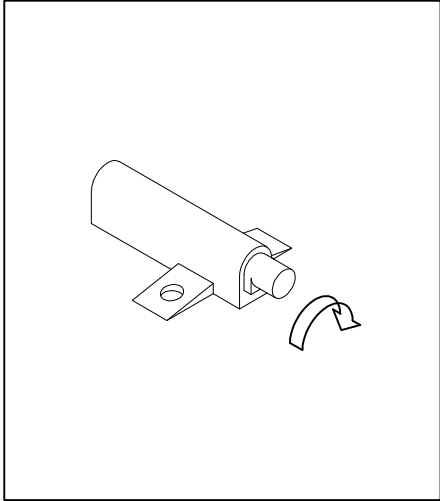

DE: Wenn die Schublade/Tür mit Auslöser (Teil: P) nach außen vorsteht, drehen Sie den Auslöser im Uhrzeigersinn, bis er sanft die Innenseite der Front berührt.

FR: Si le tiroir/porte avec loquet (Pièce : P) dépasse vers l'extérieur, tournez le loquet dans le sens horaire jusqu'à ce qu'il touche légèrement l'intérieur du panneau.

EN: If the drawer/door with push-latch (Part: P) protrudes outward, rotate the latch clockwise until it gently touches the inner side of the panel.

IT: Se il cassetto/anta con dispositivo (Parte: P) sporge verso l'esterno, ruotare il dispositivo in senso orario finché non tocca leggermente la parte interna del pannello.

ES: Si el cajón/puerta con mecanismo de retroceso (Pieza: P) sobresale hacia afuera, gire el mecanismo en sentido horario hasta que toque suavemente el interior del panel.

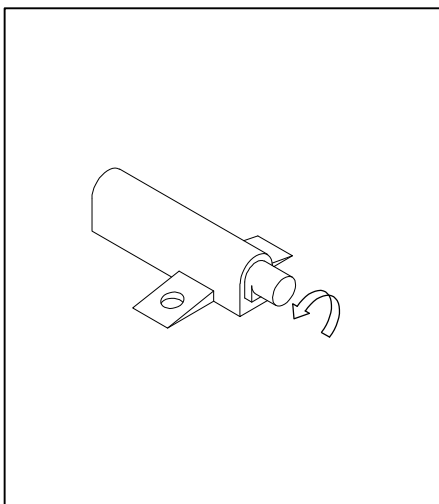

DE: Wenn die Schublade/Tür mit Auslöser (Teil: P) nach innen versenkt ist, drehen Sie den Auslöser gegen den Uhrzeigersinn, bis er sanft die Innenseite der Front berührt.

FR: Si le tiroir/porte avec loquet (Pièce : P) est enfoncé vers l'intérieur, tournez le loquet dans le sens antihoraire jusqu'à ce qu'il touche légèrement l'intérieur du panneau.

EN: If the drawer/door with push-latch (Part: P) is recessed inward, rotate the latch counterclockwise until it gently touches the inner side of the panel.

IT: Se il cassetto/anta con dispositivo (Parte: P) è rientrato verso l'interno, ruotare il dispositivo in senso antiorario finché non tocca leggermente la parte interna del pannello.

ES: Si el cajón/puerta con mecanismo de retroceso (Pieza: P) está hundido hacia adentro, gire el mecanismo en sentido antihorario hasta que toque suavemente el interior del panel.

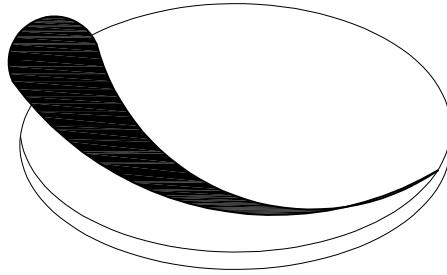

[DE]

BITTE BEACHTEN: Teilenummer 15,16,17,18 ist mit einer dichten Kunststoffschutzfolie überzogen. Wenn das Produkt nach der Demontage Kratzer aufweist, machen Sie sich bitte keine Sorgen, es handelt sich nicht um einen Produktschaden. Bitte ziehen Sie die schützende Kunststoffolie langsam entlang der Kante von der Oberfläche ab. Nach dem Abziehen wird das Produkt glatt und sauber.

[EN]

PLEASE NOTE: Part number 15,16,17,18 are covered with a tight plastic protective film. If there are scratches on the product after disassembly, please don't worry, it's not product damage. Please slowly tear off the protective plastic film on the surface along the edge. After peeling off, the product becomes smooth and clean.

[FR]

REMARQUE: les pièces numéro 15,16,17,18 sont recouvertes d'un film protecteur en plastique étanche. Si le produit présente des rayures après le démontage, ne vous inquiétez pas, il ne s'agit pas d'un dommage au produit. Retirez lentement le film protecteur en plastique sur la surface le long du bord. Une fois décollé, le produit devient lisse et propre.

[IT]

NOTA BENE: il numero di parte 15,16,17,18 è coperto da una pellicola protettiva in plastica stretta. Se ci sono graffi sul prodotto dopo lo smontaggio, non preoccuparti, non è un danno al prodotto. Strappare lentamente la pellicola protettiva in plastica sulla superficie lungo il bordo. Dopo averla staccata, il prodotto diventa liscio e pulito.

[ES]

NOTA: La pieza número 15,16,17,18 está cubierta con una película protectora de plástico. Si hay rayones en el producto después de desmontarlo, no se preocupe, no se trata de daños en el producto. Retire lentamente la película protectora de plástico de la superficie a lo largo del borde. Después de despegarla, el producto quedará liso y limpio.

# Verification of Compliance

Verification No.: TMC210319126-E

Name and address of Applicant: **Shenzhen CWG Technology Co., Ltd**  
5 / F, No.264 Baoshi East Road, Shiyan street, Bao'an District, Shenzhen,China 518108

Name and address of Manufacturer: **Shenzhen CWG Technology Co., Ltd**  
5 / F, No.264 Baoshi East Road, Shiyan street, Bao'an District, Shenzhen,China 518108

Product name: **LED Strip**

Rated: DC12V

Product model(s): CWG-5050RGB-60D-12V , additional models reference attachment

Product trademark: 创唯光

This verification confirms that the product meets the requirements of the following standard. The conformity was demonstrated based on following standard(s) listed by European Commission as harmonized with EMC Directive 2014/30/EU.

EN IEC 55015:2019+A11:2020  
IEC 61547:2020

The verification has been carried out in accordance with individual rules and conditions agreed with the applicant. Evaluation has been carried out in accordance with:

Test report(s) No.: TMC210319126-E

Test conducted by: TMC Testing Services (Shenzhen) Co., Ltd.

Verification issue date: March 26, 2021

**Notes:**

*This verification refers to the above mentioned product and its conformity in regards of above mentioned standard(s) was proven on test sample.*

*This verification does not imply meeting all essential requirements, assessment of the series-production or any other restricted Notified Bodies conformity assessment procedure appropriate for the product.*

*This verification holder shall use this verification in connection to verification of conformity and technical data relevant for the product the verification was issued.*

**TMC Testing Services (Shenzhen) Co., Ltd.**

t:86-755-86642861 cert@tmc-lab.com www.tmc-lab.com  
1st Floor, Block A1, Zone A, Xinshidai Gongrong Industrial Park, No. 2, Shihuan Road, Shiyan Street, Baoan District, Shenzhen, China



## Verification of Compliance

CWG-5050RGB-30D-12V, CWG-5050RGB-18D-12V, CWG-5050RGB-60D-24V,  
CWG-5050RGB-60D-5V, CWG-5050RGB-30D-5V, CWG-5050RGB-18D-5V,  
CWG-5050-60D-12V, CWG-5050-30D-12V, CWG-5050-60D-24V,  
CWG-HC5050RGB-60D-12V, CWG-HC5050RGB-30D-12V,  
CWG-HC5050RGB-60D-24V, CWG-HC5050-60D-12V, CWG-HC5050-30D-12V,  
CWG-HC5050-60D-24V, CWG-HC5050RGB-30D-5V, CWG-HC5050RGB-60D-5V,  
CWG-HC5050RGB-144D-5V, CWG-2835-60D-12V, CWG-2835-120D-12V,  
CWG-2835-60D-24V, CWG-2835-120D-24V, CWG-2835-60D-5V, CWG-2835-120D-5V

Note:

This attachment only valided with Verification No.: TMC210319126-E