

Installationsanleitung/Installation Instruction/Instruction d'installation
Istruzioni di installazione/Instrucciones de instalación
Installatie-instructies/Installationsanvisningar/Instrukcje instalacji
BADEZIMMERSCHRAN-N877P401893/N877P401894

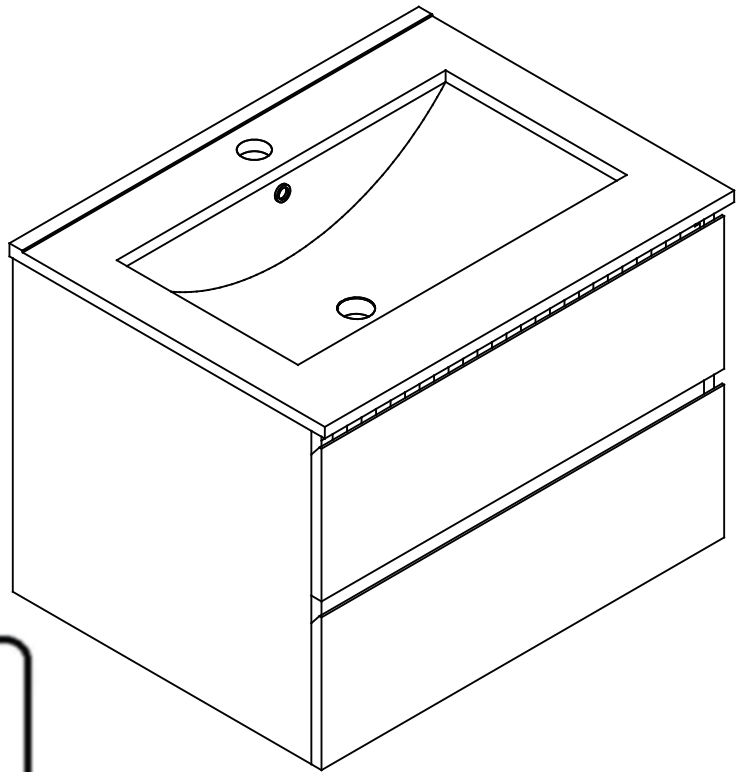

CE



FR

Vous êtes responsable de remettre tous les appareils électriques et électroniques usagés à des points de collecte correspondants.

Pour en savoir plus:
[www. quefairedemesdechets.fr](http://www.quefairedemesdechets.fr)

DE: Unser Produkt wird Ihnen in 2 Paketen geliefert. Die Lieferzeiten dieser 2 Pakete können abweichen, bitte haben Sie etwas Geduld und vielen Dank für Ihr Verständnis.

UK: Our product will be delivered to you in 2 packages. The delivery times of these 2 packages may differ, please be patient and thank you for your understanding.

FR: Notre produit vous sera livré en 2 colis. Les délais de livraison de ces 2 colis peuvent différer, soyez patient et merci pour votre compréhension.

IT: Il nostro prodotto verrà consegnato in 2 pacchi. I tempi di consegna di questi 2 pacchi possono variare; vi preghiamo di avere un po' di pazienza e vi ringraziamo per la vostra comprensione.

ES: Nuestro producto se entregará en 2 paquetes. Los tiempos de entrega de estos 2 paquetes pueden variar; por favor, tenga un poco de paciencia y gracias por su comprensión.

NL: Ons product wordt in 2 pakketten bij u geleverd. De levertijden van deze 2 pakketten kunnen verschillen, we vragen om uw geduld en bedanken u voor uw begrip.

SE: Vår produkt kommer att levereras till dig i 2 paket. Leveranstiderna för dessa 2 paket kan variera, vi ber om ditt tålamod och tackar för din förståelse.

PL: Nasz produkt zostanie dostarczony w 2 paczkach. Czas dostawy tych 2 paczek może się różnić, prosimy o cierpliwość i dziękujemy za zrozumienie.

DE

Sicherheitswarnungen für die Verwendung

Erlauben Sie Kindern nicht, auf Möbel zu klettern, da dies zu Umkippen und schweren Verletzungen führen kann. Bitte nicht überlasten.

Warnungen zur Installation

Um die Sicherheit zu gewährleisten, befolgen Sie bitte die Anweisungen zur ordnungsgemäßen Installation und bitten Sie gegebenenfalls um professionelle Hilfe. Um ein Umkippen zu verhindern, befestigen Sie die Möbel mit den mitgelieferten Dübeln an der Wand.

Warnungen zur Verwendung in der Umgebung

Vermeiden Sie die Gefahr eines Brandes, indem Sie die Möbel nicht in der Nähe von Zündquellen oder heißen Gegenständen aufstellen. Lassen Sie die Möbel nicht in einer feuchten Umgebung stehen, um Materialschäden zu vermeiden.

Wartungs- und Pflegehinweise

Bitte überprüfen Sie regelmäßig alle Verbindungen und Befestigungselemente, um die Sicherheit zu gewährleisten und Unfälle zu vermeiden. Verwenden Sie für die Reinigung Ihrer Möbel empfohlene Reinigungsmittel und vermeiden Sie Reinigungsmittel mit aggressiven Chemikalien.

Hinweise zur Nutzung des Waschbeckens

Halten Sie das Waschbecken im täglichen Gebrauch sauber, und entfernen Sie Waschmittelreste rechtzeitig. Lassen Sie kein Wasser längere Zeit im Becken stehen, um es trocken zu halten und die Lebensdauer zu verlängern. Vermeiden Sie direkte Zugabe von zu heißem Wasser, da dies die Lebensdauer des Beckens verkürzen kann.

FR

Avvertissements de sécurité pour l'utilisation

Ne laissez pas les enfants grimper sur les meubles, car cela pourrait entraîner un basculement et des blessures graves. Ne surchargez pas les meubles.

Avvertissements d'installation

Pour garantir la sécurité, suivez les instructions pour une installation correcte et demandez une aide professionnelle si nécessaire. Pour éviter le basculement, fixez les meubles au mur à l'aide des chevilles fournies.

Avvertissements d'utilisation environnementale

Évitez les risques d'incendie en ne plaçant pas les meubles près de sources de chaleur ou d'objets chauds. Évitez de placer les meubles dans un environnement humide afin de prévenir les dommages aux matériaux.

Conseils d'entretien et de maintenance

Vérifiez régulièrement toutes les connexions et fixations pour garantir la sécurité et éviter les accidents. Utilisez des produits de nettoyage recommandés pour vos meubles et évitez les produits contenant des produits chimiques agressifs.

Précautions d'utilisation du lavabo

Gardez le lavabo propre lors de son utilisation quotidienne et éliminez rapidement les résidus de détergent. Ne laissez pas l'eau stagner dans le lavabo pendant de longues périodes et maintenez-le sec pour prolonger sa durée de vie. Évitez de verser de l'eau trop chaude directement dans le lavabo, car les changements de température rapides peuvent réduire sa durée de vie.

ES

Advertencias de seguridad para el uso

No permita que los niños trepen a los muebles, ya que esto puede provocar vuelcos y lesiones graves. No sobrecargue los muebles.

Advertencias de instalación

Para garantizar la seguridad, siga las instrucciones para una instalación adecuada y, si es necesario, solicite ayuda profesional. Para evitar vuelcos, asegure los muebles a la pared utilizando los pernos de expansión suministrados.

Advertencias de uso ambiental

Evite riesgos de incendio no colocando los muebles cerca de fuentes de calor u objetos calientes. Evite colocar los muebles en ambientes húmedos para prevenir daños en los materiales.

Consejos de mantenimiento y cuidado

Revise regularmente todas las conexiones y fijaciones para garantizar la seguridad y evitar accidentes. Utilice productos de limpieza recomendados para sus muebles y evite limpiadores con químicos agresivos.

Precauciones para el uso del lavabo

Mantenga el lavabo limpio durante el uso diario y elimine rápidamente los residuos de detergente. No deje agua estancada en el lavabo durante períodos prolongados y manténgalo seco para prolongar su vida útil. Evite verter agua excesivamente caliente directamente en el lavabo, ya que los cambios rápidos de temperatura pueden acortar su vida útil.

SE

Säkerhetsvarningar för användning

Låt inte barn klättra på möbler eftersom detta kan leda till att de välter och orsakar allvarliga skador. Överbelasta inte möblerna.

Installationsvarningar

Följ instruktionerna för korrekt installation för att säkerställa säkerheten, och be om professionell hjälp vid behov. För att förhindra att möbler välter, fäst dem vid väggen med de medföljande pluggarna.

Miljövarningar vid användning

Undvik brandrisk genom att inte placera möbler nära värmekällor eller heta föremål. Undvik att placera möbler i fuktiga miljöer för att förhindra materialskador.

Underhålls- och vårdtips

Kontrollera regelbundet alla anslutningar och fästelement för att säkerställa säkerheten och undvika olyckor. Använd rekommenderade rengöringsprodukter för möbler och undvik rengöringsmedel med starka kemikalier.

Försiktighetsåtgärder för användning av tvättställ

Håll tvättstället rent vid daglig användning och ta bort rester av rengöringsmedel i tid. Låt inte vatten stå kvar i tvättstället under längre perioder och håll det torrt för att förlänga dess livslängd. Undvik att hålla för varmt vatten direkt i tvättstället eftersom snabba temperaturförändringar kan förkorta dess livslängd.

UK

Safety Warnings for Use

Do not allow children to climb on furniture, as this may cause tipping and severe injuries. Do not overload.

Installation Warnings

To ensure safety, follow the instructions for proper installation, and seek professional help if necessary. To prevent tipping, secure the furniture to the wall using the supplied expansion bolts.

Environmental Usage Warnings

Avoid fire hazards by not placing furniture near ignition sources or hot objects. Avoid placing furniture in humid environments to prevent material damage.

Maintenance and Care Tips

Regularly check all connections and fasteners to ensure safety and avoid accidents. Use recommended cleaning products for your furniture, and avoid cleaners with harsh chemicals.

Washbasin Usage Precautions

Keep the basin clean during daily use, and promptly remove detergent residues. Do not leave water standing in the basin for prolonged periods; keep it dry to extend its lifespan. Avoid pouring excessively hot water directly into the basin, as rapid temperature changes may shorten its lifespan.

IT

Avvertenze di sicurezza per l'uso

Non permettere ai bambini di arrampicarsi sui mobili, poiché ciò potrebbe causare ribaltamenti e gravi lesioni. Non sovraccaricare.

Avvertenze per l'installazione

Per garantire la sicurezza, seguire le istruzioni per un'installazione corretta e richiedere assistenza professionale se necessario. Per evitare ribaltamenti, fissare i mobili al muro utilizzando i tasselli in dotazione.

Avvertenze sull'uso ambientale

Evitare rischi di incendio non posizionando i mobili vicino a fonti di calore o oggetti caldi. Evitare di posizionare i mobili in ambienti umidi per prevenire danni ai materiali.

Consigli per la manutenzione e la cura

Controllare regolarmente tutte le connessioni e gli elementi di fissaggio per garantire la sicurezza ed evitare incidenti. Utilizzare prodotti di pulizia raccomandati per i mobili ed evitare detersivi con sostanze chimiche aggressive.

Precauzioni per l'uso del lavabo

Mantenere il lavabo pulito durante l'uso quotidiano e rimuovere tempestivamente i residui di detergente. Non lasciare acqua stagnante nel lavabo per lunghi periodi e mantenerlo asciutto per prolungarne la durata. Evitare di versare acqua eccessivamente calda direttamente nel lavabo, poiché i cambiamenti di temperatura rapidi possono ridurre la durata.

NL

Veiligheidswaarschuwingen voor gebruik

Laat kinderen niet op meubels klimmen, omdat dit kantelen en ernstig letsel kan veroorzaken. Niet overbelasten.

Waarschuwingen voor installatie

Volg de instructies voor een juiste installatie om de veiligheid te waarborgen, en vraag indien nodig om professionele hulp. Bevestig meubels aan de muur met de meegeleverde pluggen om kantelen te voorkomen.

Waarschuwingen voor omgevingsgebruik

Vermijd brandgevaar door meubels niet in de buurt van warmtebronnen of hete voorwerpen te plaatsen. Vermijd het plaatsen van meubels in een vochtige omgeving om materiaalbeschadiging te voorkomen.

Onderhouds- en verzorgingstips

Controleer regelmatig alle verbindingen en bevestigingen om de veiligheid te garanderen en ongevallen te voorkomen. Gebruik aanbevolen reinigingsmiddelen voor uw meubels en vermijd schoonmaakmiddelen met agressieve chemicaliën.

Voorzorgsmaatregelen voor het gebruik van de wastafel

Houd de wastafel schoon bij dagelijks gebruik en verwijder direct resten van reinigingsmiddelen. Laat geen water lang in de wastafel staan en houd deze droog om de levensduur te verlengen. Vermijd het direct inschenken van te heet water, omdat snelle temperatuurswisselingen de levensduur kunnen verkorten.

PL

Ostrzeżenia dotyczące bezpieczeństwa użytkowania

Nie pozwalaj dzieciom wspinać się na meble, ponieważ może to spowodować ich przewrócenie i poważne obrażenia. Nie przeciążaj mebli.

Ostrzeżenia dotyczące instalacji

Aby zapewnić bezpieczeństwo, postępuj zgodnie z instrukcją prawidłowego montażu i w razie potrzeby skorzystaj z pomocy specjalisty. Aby zapobiec przewróceniu mebli, przymocuj je do ściany za pomocą dołączonych kołków rozporowych.

Ostrzeżenia dotyczące użytkowania w środowisku

Unikaj ryzyka pożaru, nie umieszczając mebli w pobliżu źródeł ognia ani gorących przedmiotów. Unikaj umieszczania mebli w wilgotnym środowisku, aby zapobiec uszkodzeniu materiałów.

Wskazówki dotyczące konserwacji i pielęgnacji

Regularnie sprawdzaj wszystkie połączenia i elementy mocujące, aby zapewnić bezpieczeństwo i uniknąć wypadków. Do czyszczenia mebli używaj zalecanych środków czyszczących i unikaj środków zawierających agresywne chemikalia.

Środki ostrożności dotyczące użytkowania umywalki

Utrzymuj umywalkę w czystości podczas codziennego użytkowania i usuwaj resztki detergentu na bieżąco. Nie pozostawiaj wody w umywalce na dłuższy czas i utrzymuj ją suchą, aby wydłużyć jej żywotność. Unikaj wlewania zbyt gorącej wody bezpośrednio do umywalki, ponieważ szybkie zmiany temperatury mogą skrócić jej trwałość.

DE: Vor dem Einbau die Schrauben in die Löcher stecken und festziehen, aber nicht bis 100%, 70% bis 80% anziehen reicht aus. Schließlich, nachdem alle Schrauben installiert sind, ziehen Sie alle Schrauben auf 100%.

Wenn Sie auf diese Probleme stoßen, wie z. B. Fehlausrichtung der Löcher oder Unfähigkeit, bestimmte Teile zu installieren, überprüfen Sie bitte, ob die Schrauben korrekt verwendet werden und passen Sie die Dichtigkeit der Schrauben an.

UK: Before installation, insert the screws into the holes and tighten them, but do not tighten them to 100%, 70% to 80% is sufficient. Finally, after all screws are installed, tighten all screws to 100%.

If you encounter these issues, such as if the holes cannot be aligned or some parts cannot be installed, please check if the screws are used correctly and adjust the tightness of the screws.

FR: Insérer la vis dans le trou avant la fin de l'assemblage, serrer la vis, mais ne pas serrer à 100%, 70% ~ 80% est correct. Enfin, une fois que toutes les vis sont bien serrées, toutes les vis sont serrées à 100%.

Si vous rencontrez ces problèmes, par exemple si les trous ne sont pas alignés ou si certaines pièces ne peuvent pas être montées, vérifiez que les vis sont utilisées correctement et Ajustez leur serrage.

IT: Prima dell'installazione, inserire le viti nei fori e stringerle, ma non al 100%, è sufficiente stringerle al 70% - 80%. Infine, dopo aver installato tutte le viti, stringere tutte le viti al 100%. Se riscontri problemi come disallineamenti dei fori o difficoltà nell'installare alcuni componenti, verifica che le viti siano utilizzate correttamente e regola la tensione delle viti.

ES: Antes de la instalación, coloque los tornillos en los agujeros y apriéte los, pero no al 100%; apretar al 70% - 80% es suficiente. Finalmente, después de haber instalado todos los tornillos, apriete todos los tornillos al 100%. Si se encuentra con problemas como desalineación de los agujeros o dificultad para instalar ciertas piezas, verifique que los tornillos se estén utilizando correctamente y ajuste la tensión de los tornillos.

NL: Voordat u begint met de installatie, plaatst u de schroeven in de gaten en draait u ze aan, maar draai ze niet volledig aan; 70% tot 80% is voldoende. Draai uiteindelijk, nadat alle schroeven zijn geplaatst, alle schroeven volledig aan. Als u problemen ondervindt, zoals niet uitgelijnde gaten of onderdelen die niet kunnen worden geïnstalleerd, controleer dan of de schroeven correct zijn gebruikt en pas de spanning van de schroeven aan.

SE: Innan installation, sätt i skruvarna i hålen och dra åt dem, men dra inte åt dem helt; 70% till 80% är tillräckligt. Slutligen, när alla skruvar är installerade, dra åt alla skruvar helt. Om du stöter på problem, som att hålen inte kan justeras eller vissa delar inte kan installeras, kontrollera om skruvarna används korrekt och justera skruvarnas åtdragning.

PL: Przed instalacją wstaw śruby w otwory i dokręć je, ale nie dokręcaj ich na 100%; 70% do 80% wystarczy. Na koniec, po zainstalowaniu wszystkich śrub, dokręć wszystkie śruby do 100%. Jeśli napotkasz problemy, takie jak niedopasowane otwory lub części, które nie mogą być zainstalowane, sprawdź, czy śruby są używane prawidłowo i dostosuj ich dokręcenie.

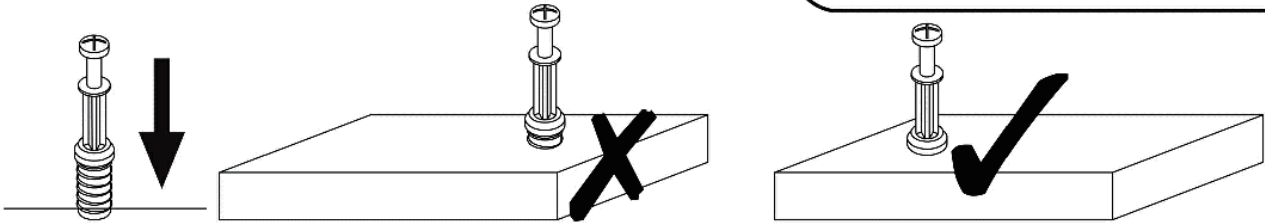

EN_QUICKFIT: Tighten quickfit until shoulder is flush with panel. Do not overtighten or undertighten.

FR_RACCORD RAPIDE: Faites serrer le raccord rapide jusqu'à ce que l'épaulement soit parfaitement encastré dans le panneau. Il ne faut ni trop serrer ni insuffisamment serrer.

ES_QUICKFIT: Apriete quickfit hasta que el hombro se descargue con el panel. NO lo sobreapriete ni lo apriete poco.

DE_QUICKFIT: Ziehen Sie den Quickfit fest, bis die Schulter mit der Platte bündig ist. Bitte nicht zu fest oder zu schwach anziehen.

IT_MONTAGGIO RAPIDO: Stringere il montaggio rapido fino a quando la spalla è a filo con il pannello, non stringere troppo o troppo poco.

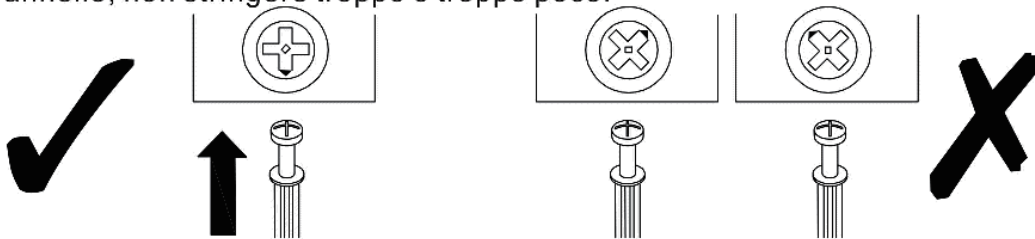

EN_CAM LOCK: When fitting cam lock, ensure starting position is correct before you insert connecting quickfit.

FR_SERRURE BATTEUSE: Avant d'insérer la serrure batteuse, veillez à la bonne orientation avant d'insérer le raccord rapide.

ES_CIERRE DE LA CÁMARA: Cuando instale el cierre de la cámara, asegúrese de que la posición de inicio es correcta antes de que inserte el quickfit conector.

DE_CAM-LOCK: Achten Sie bei der Montage des Cam-Locks auf die richtige Ausgangsposition, bevor Sie den Quickfit einsetzen.

IT_BLOCCAGGIO A CAMMA: Quando si monta il bloccaggio a camma, assicurarsi che la posizione iniziale sia corretta prima di inserire il montaggio rapido di collegamento.

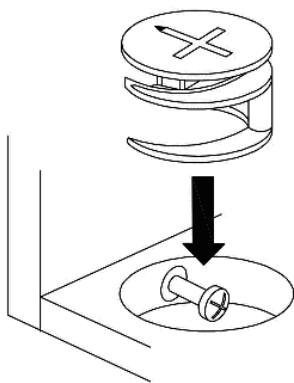

EN_Quickfit head should be in the centre of the cam lock when the two panels are joined.

Cam lock should be inserted before quickfit.

FR_Lorsque les deux panneaux sont assemblés, la tête du raccord rapide doit reposer au centre de la serrure batteuse. Il faut insérer la serrure batteuse avant le raccord rapide.

ES_El cabezal del quickfit debe estar en el centro del cierre de la cámara cuando se unan los dos paneles.

Se debe insertar el cierre de la cámara antes que el quickfit.

DE_Der Quickfit-Kopf sollte sich in der Mitte des Cam-Locks befinden, wenn die beiden Platten zusammengefügt sind.

Der Cam-Lock sollte vor dem Quickfit eingesetzt werden.

IT_La testa del montaggio rapido deve trovarsi al centro del bloccaggio a camma quando i due pannelli sono uniti.

Il Bloccaggio a Camma deve essere inserito prima del montaggio rapido.

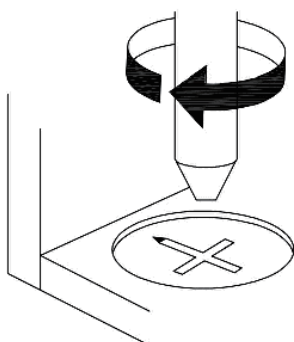

EN_Turn cam lock clockwise to tighten.

FR_Faites tourner la serrure batteuse dans le sens des aiguilles d'une montre pour la resserrer.

ES_Gire el cierre de la cámara en sentido horario para apretarlo.

DE_Drehen Sie den Cam-Lock im Uhrzeigersinn, um ihn festzuziehen.

IT_Ruotare il bloccaggio a camma in senso orario per stringere.

·Components - fittings

Please check you have all the panels listed below.

Note: The quantities below are the correct amount to complete the assembly. In some cases more fittings may be supplied than are required.

·Komponenten Verschraubungen

Bitte überprüfen Sie, ob Sie alle unten aufgeführten Panels haben.

Hinweis: Die folgende Menge ist die richtige Menge, um die Montage abzuschließen. In einigen Fällen können mehr Armaturen geliefert werden, als erforderlich.

·Composants - accessoires

Veuillez vérifier que vous possédez tous les panneaux énumérés ci - dessous.

Remarque: les quantités ci - dessous sont les quantités correspondantes nécessaires pour terminer l'assemblage. Dans certains cas, plus d'accessoires que nécessaire peuvent être fournis.

·Componenti - accessori

Controlla di avere tutti i pannelli elencati di seguito.

Nota: i quantitativi indicati di seguito rappresentano il quantitativo corrispondente al completamento del montaggio. In alcuni casi possono essere forniti più accessori di quelli necessari.

·Componentes y accesorios

Por favor compruebe que tiene todos los paneles que se enumeran a continuación.

Nota: las cantidades de abajo son la cantidad de correctet para completar el montaje. En algunos casos pueden suministrarse más accesorios de los necesarios.

·Componenten - toebehoren

Controleer of u alle panelen hieronder heeft.

Opmerking: de volgende hoeveelheden zijn de juiste hoeveelheid voor de complete montage. In sommige gevallen kunnen er meer accessoires worden geleverd dan nodig is.

·Komponenter - kopplingar

Kontrollera att du har alla paneler listade nedan.

Notera: Kvantiteten nedan är det korrekta beloppet för att slutföra monteringen. I vissa fall kan fler kopplingar levereras än vad som krävs.

·Komponenty - okucia

Kontrollera att du har alla paneler listade nedan.

Notera: Kvantiteten nedan är det korrekta beloppet för att slutföra monteringen. I vissa fall kan fler kopplingar levereras än vad som krävs.

N877P401893 - Box:1/2

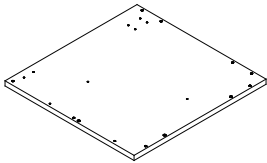
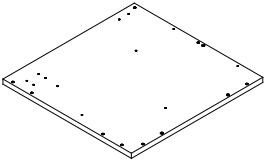
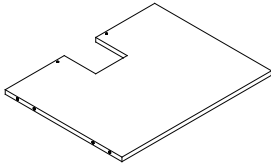
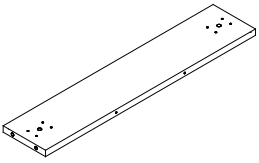
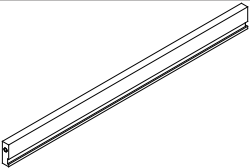
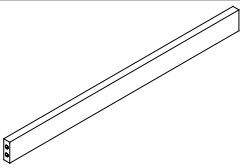
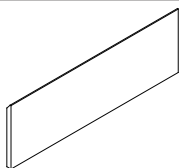
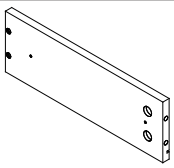
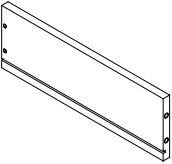
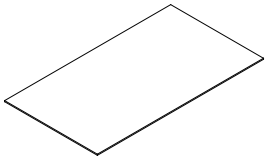
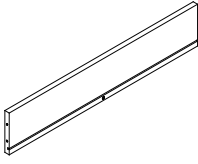
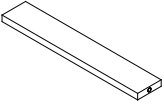
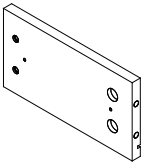
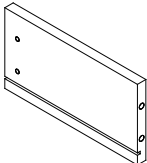
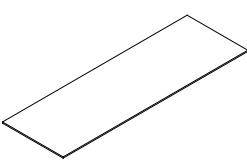
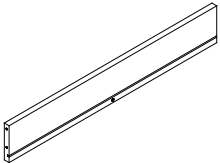
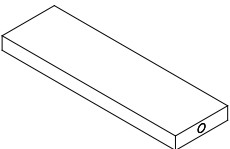
			
① x 1pcs	② x 1pcs	③ x 1pcs	④ x 2pcs
			
⑤ x 1pcs	⑥ x 1pcs	⑦ x 2pcs	⑧ x 1pcs
			
⑨ x 1pcs	⑩ x 1pcs	⑪ x 1pcs	⑫ x 1pcs
			
⑬ x 1pcs	⑭ x 1pcs	⑮ x 1pcs	⑯ x 1pcs
			
⑰ x 1pcs			

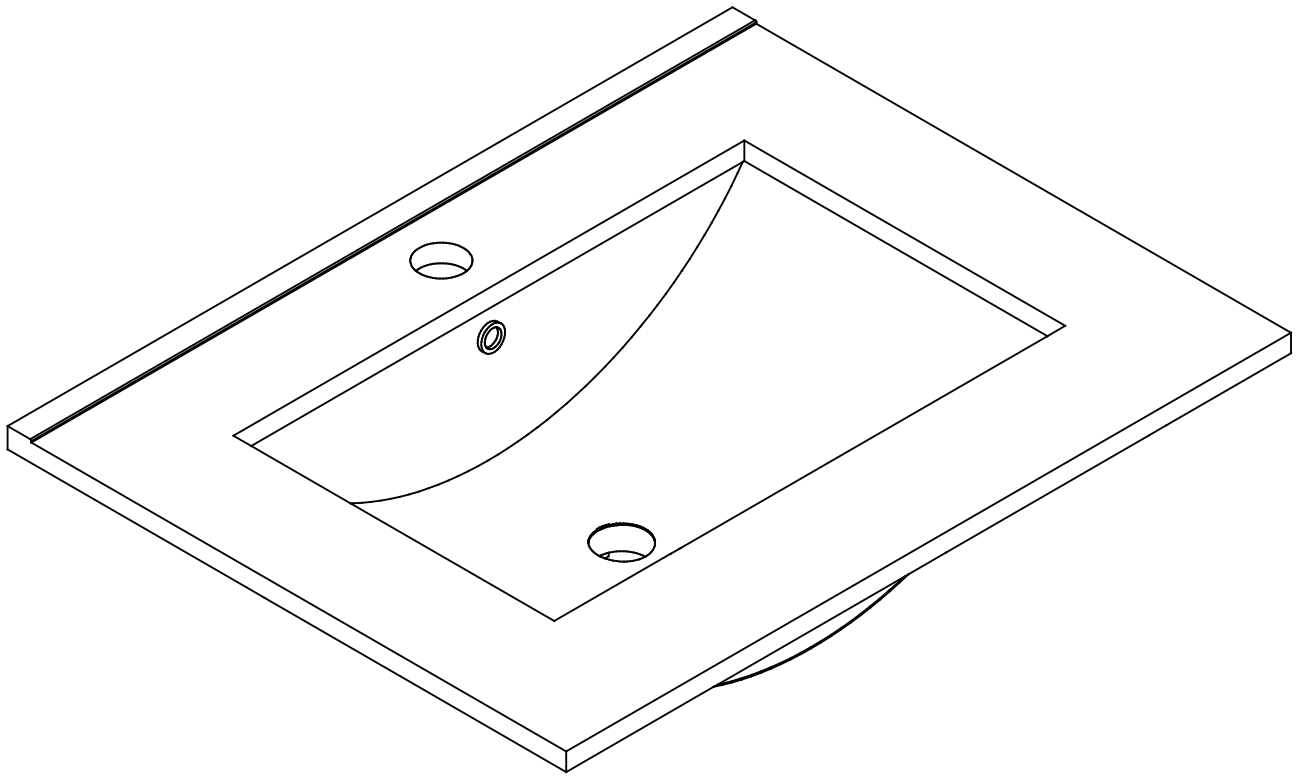

·Components - fittings

Please check you have all the panels listed below.

Note: The quantities below are the correct amount to complete the assembly. In some cases more fittings may be supplied than are required.

·Komponenten Verschraubungen

Bitte überprüfen Sie, ob Sie alle unten aufgeführten Panels haben.

Hinweis: Die folgende Menge ist die richtige Menge, um die Montage abzuschließen. In einigen Fällen können mehr Armaturen geliefert werden, als erforderlich.

·Composants - accessoires

Veillez vérifier que vous possédez tous les panneaux énumérés ci - dessous.

Remarque: les quantités ci - dessous sont les quantités correspondantes nécessaires pour terminer l'assemblage. Dans certains cas, plus d'accessoires que nécessaire peuvent être fournis.

·Componenti - accessori

Controlla di avere tutti i pannelli elencati di seguito.

Nota: i quantitativi indicati di seguito rappresentano il quantitativo corrispondente al completamento del montaggio. In alcuni casi possono essere forniti più accessori di quelli necessari.

·Componentes y accesorios

Por favor compruebe que tiene todos los paneles que se enumeran a continuación.

Nota: las cantidades de abajo son la cantidad de correct para completar el montaje. En algunos casos pueden suministrarse más accesorios de los necesarios.

·Componenten - toebehoren

Controleer of u alle panelen hieronder heeft.

Opmerking: de volgende hoeveelheden zijn de juiste hoeveelheid voor de complete montage. In sommige gevallen kunnen er meer accessoires worden geleverd dan nodig is.

·Komponenter - kopplingar

Kontrollera att du har alla paneler listade nedan.









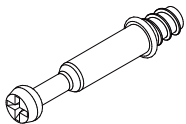

Notera: Kvantiteten nedan är det korrekta beloppet för att slutföra monteringen. I vissa fall kan fler kopplingar levereras än vad som krävs.

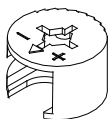

·Komponenty - okucia

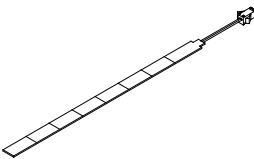
Kontrollera att du har alla paneler listade nedan.

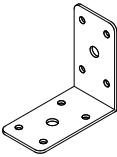
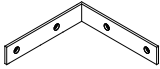
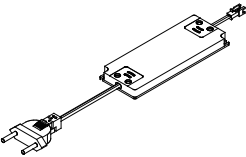
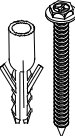
Notera: Kvantiteten nedan är det korrekta beloppet för att slutföra monteringen. I vissa fall kan fler kopplingar levereras än vad som krävs.

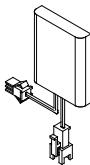
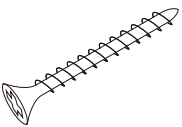
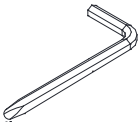
Hardware-Liste :N877P401893 - Box:1/2

	 Φ6x30mm		
A x 26+2pcs	B x 6+1pcs	C x 26+2pcs	D x 2pcs
 M3x12mm			 M4x40mm
E x 18+1pcs	F x 2pcs	G x 1pcs	H x 2pcs
 M3.5*14mm			
I x 24+2pcs	J x 2pcs	K x 2pcs	L x 1pcs
			 M4x30mm
M x 2set	N x 1pc	O x 1pc	P x 10+1pcs
			
Q x 1pc			

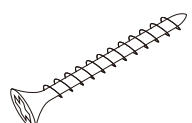
 M3x12mm	 M3.5*14mm	 M4x40mm	 M4x30mm
E x 18+1pcs	I x 24+2pcs	H x 2pcs	P x 10+1pcs

DE: Bitte beachten Sie, dass die Formen der Schrauben E und I und H und P ähnlich sind. Bitte installieren Sie entsprechend der Anleitung und unterscheiden Sie sie!

UK: Please note that the shapes of screws E and I and H and P are similar. Please install according to the instructions and distinguish them!

FR: Notez que les vis E et I et H et P et ont des formes similaires. Veuillez les installer en suivant les instructions pour les séparer!

IT: Si prega di notare che le forme delle viti E, I, H e P sono simili. Si prega di installarle seguendo le istruzioni e di distinguerle!

ES: Por favor, tenga en cuenta que las formas de los tornillos E, I, H y P son similares. Por favor, instálelos de acuerdo con las instrucciones y distíngalos.

NL: Let op, de vormen van schroeven E, I, H en P zijn vergelijkbaar. Installeer volgens de instructies en maak onderscheid tussen ze!

SE: Observera att formerna på skruvarna E, I, H och P är lika. Installera enligt anvisningarna och särskilj dem!

PL: Zauważ, że kształty śrub E, I, H i P są podobne. Zainstaluj zgodnie z instrukcjami i rozróżnij je!

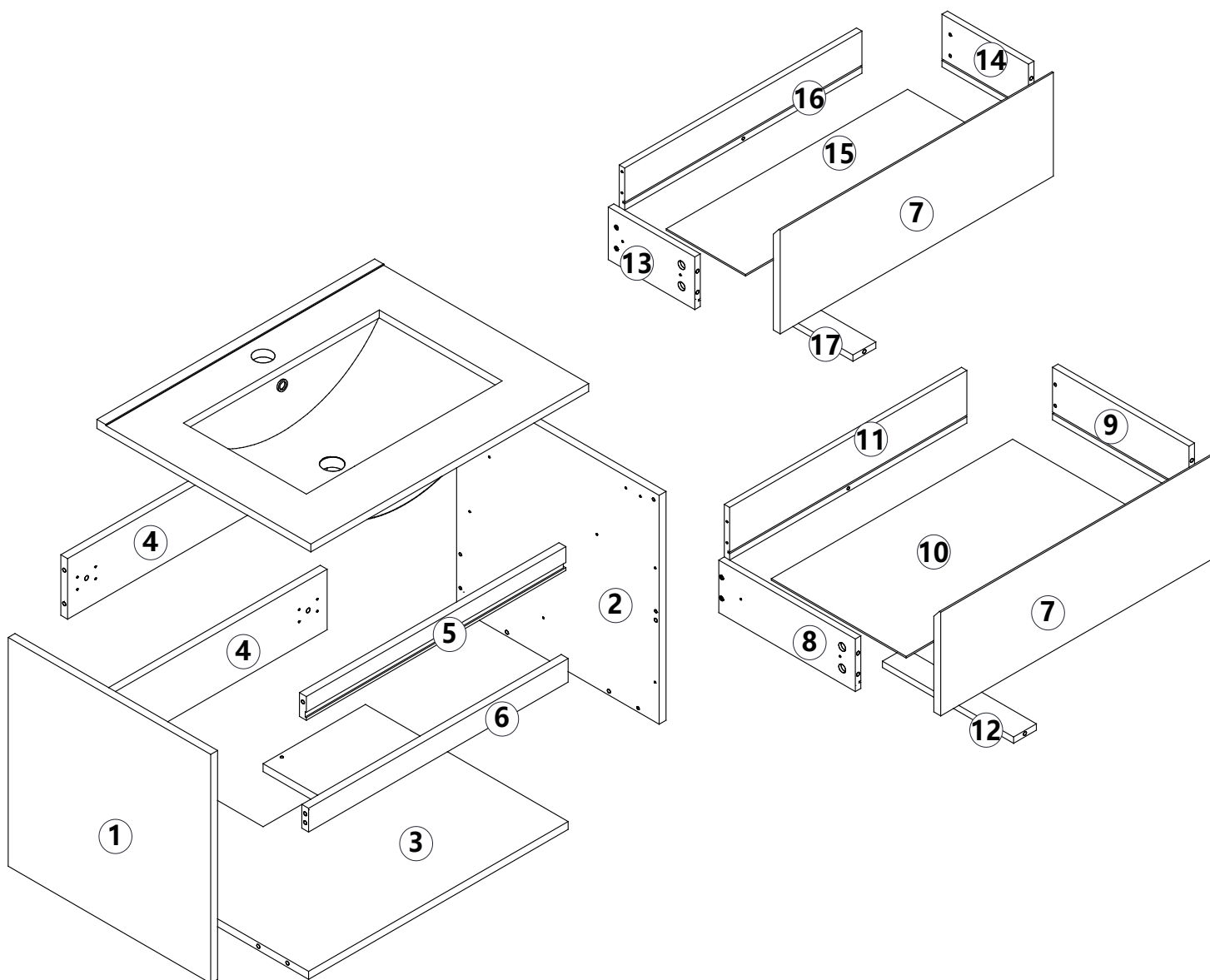

Importeur	Decobus Handel GmbH
Adresse	Innungsstraße 9, 21244 Buchholz, Deutschland
URL	https://www.decobusgroup.de
Hersteller	Shenzhen xu xing technology co., LTD
Adresse	Floor 3, building C, Huaze hi tech Industrial Park, Shiyan street, Bao'an District, Shenzhen
Email/URL	postmaster@aoc-cert.com
Partienummer	C899DEN20250818NK
Hergestellt in	CHINA
EC REP	Decobus Handel GmbH Innungsstraße 9, 21244 Buchholz, Deutschland https://www.decobusgroup.de

Produkt:LED Power Supply
Model: JNCE-24W-01
SEC:Constant current:
 DC12V 2000mA±5%
 Ta:40 TC:85 Made In China



Produkt:Two tone light strip
Modell:6X2835-WY
Nennspannung:12V
Nennfrequenz:50/60 Hz
Leistung:9.6W/m

1

Ziehen Sie die inneren und äußeren Schubladenführungen auseinander, bevor Sie sie an den Platten befestigen
Tirez les glissières de tiroir intérieures et extérieures avant de les fixer au panneau

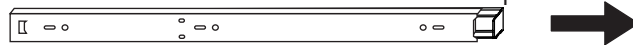

Schieben Sie Schubladenführungen auseinander, bis das Schubladenschloss sichtbar ist, wie abgebildet.
Faites glisser les glissières du tiroir jusqu'à ce que vous puissiez voir la serrure du tiroir, comme illustré.

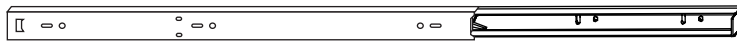

Äußerer Lauf
Roue externe

INNER RUNNER
Roue intérieure

Drücken und halten Sie die Schubladenläuferverriegelung gedrückt und fahren Sie dann fort, die Schubladenläufer auseinander zu schieben, wie gezeigt.

Appuyez et maintenez le verrou de la glissière du tiroir enfoncé, puis continuez à glisser la glissière du tiroir vers l'extérieur, comme illustré.

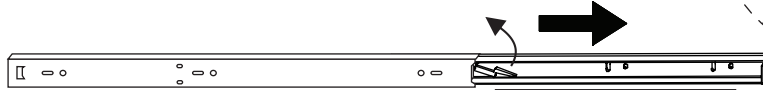
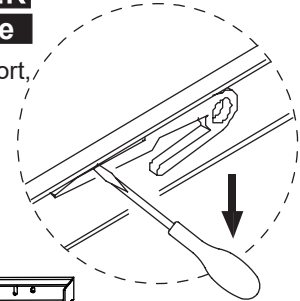

Äußerer Lauf
Roue externe

INNER RUNNER
Roue intérieure

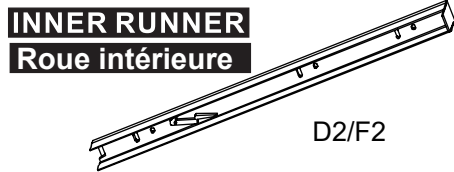
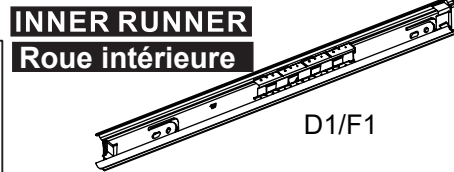

INNER RUNNER
Roue intérieure

INNER RUNNER
Roue intérieure

F x 2pcs

D x 2pcs

Ihre inneren und äußeren Schubladenführungen sind bereit, an Platten befestigt zu werden.
Vos tiroirs intérieurs et extérieurs sont prêts à être fixés au panneau.

2

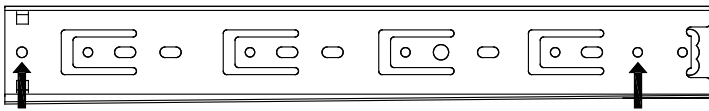

D1

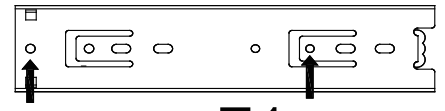

F1

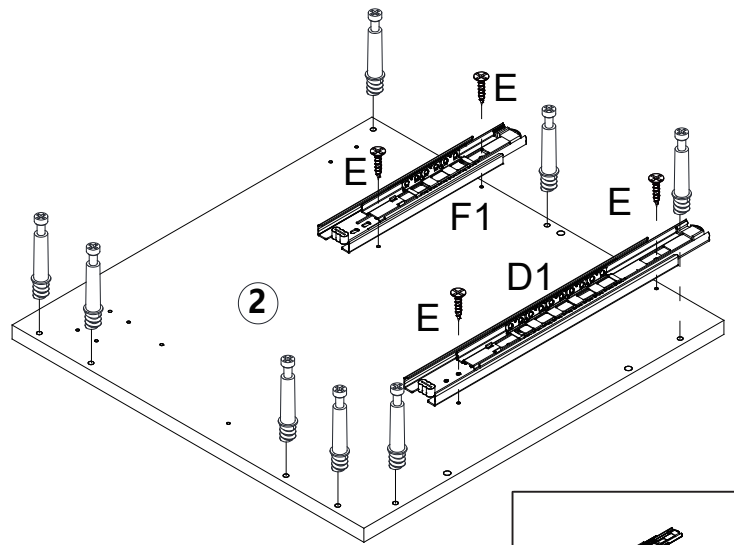
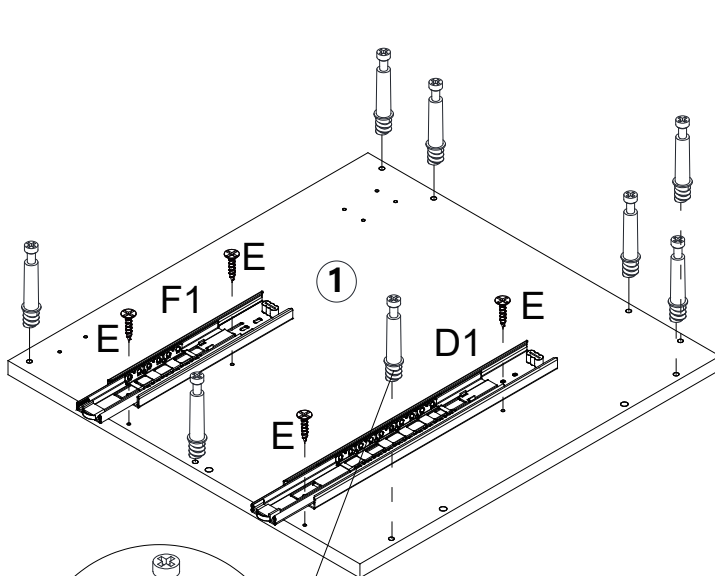

F1 x 2pcs

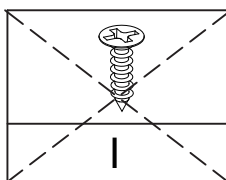
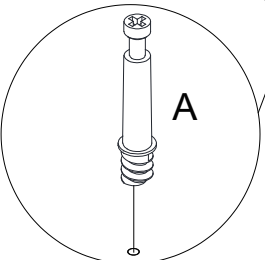

D1 x 2pcs



E x 8pcs



A x 16pcs

3

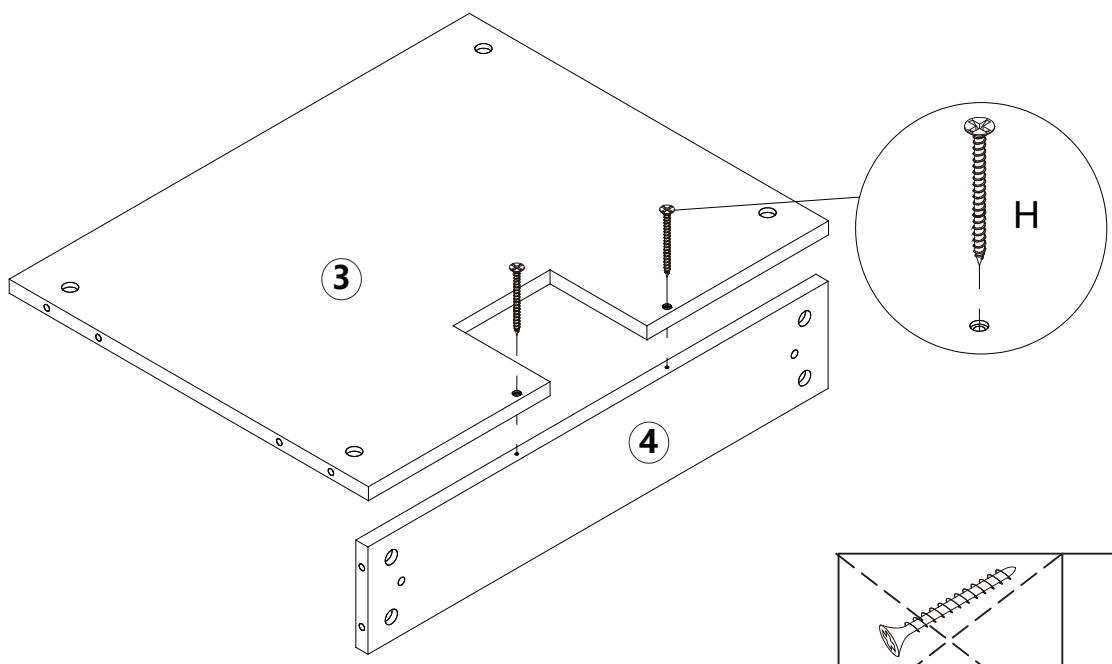

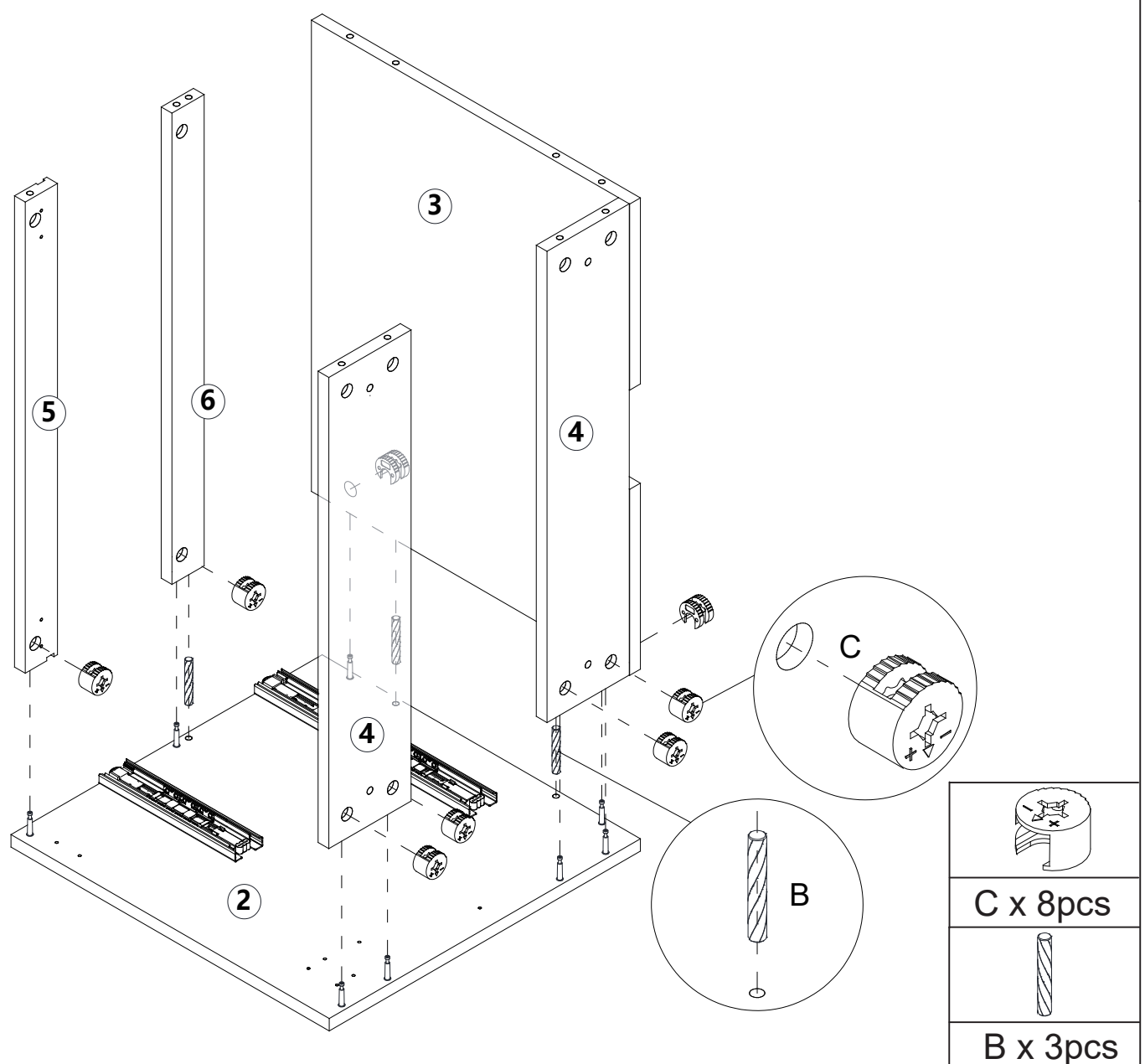

4



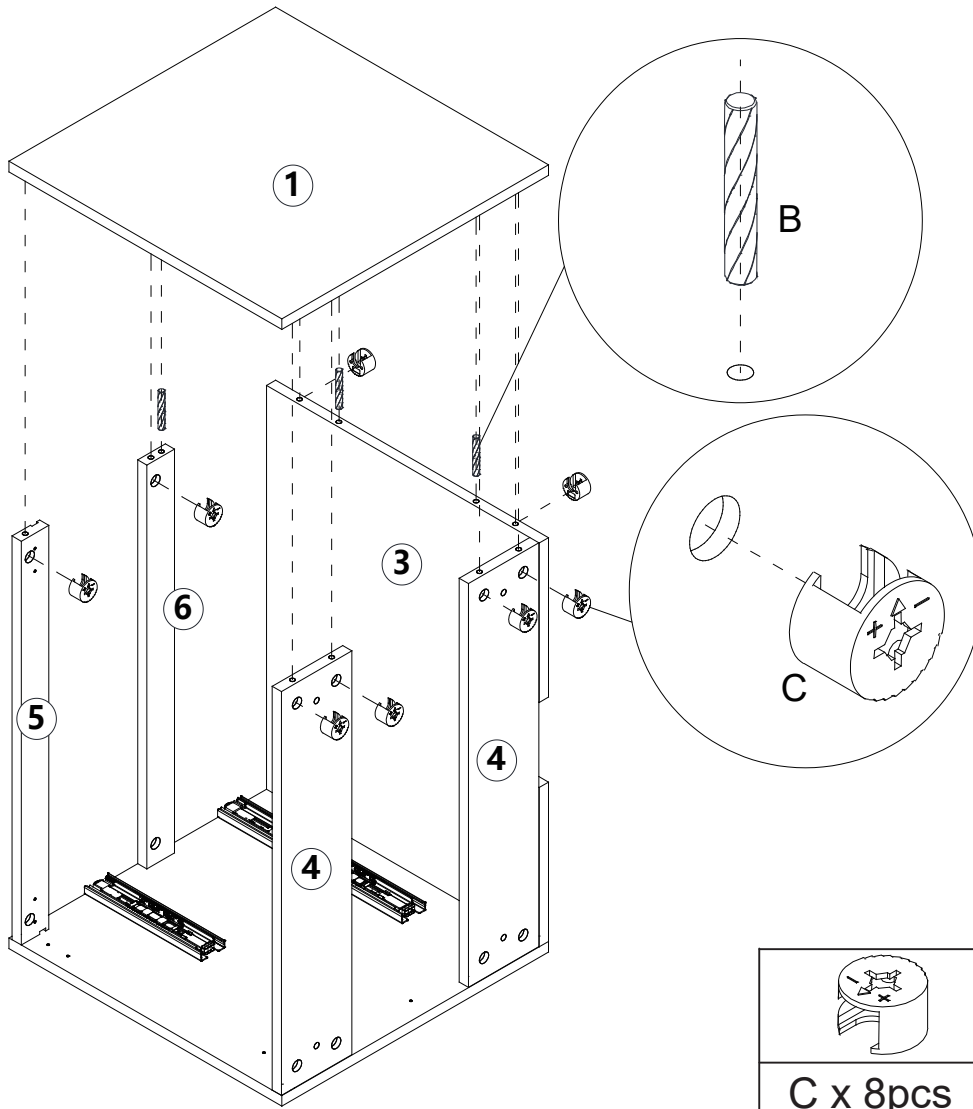

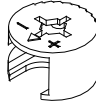
6

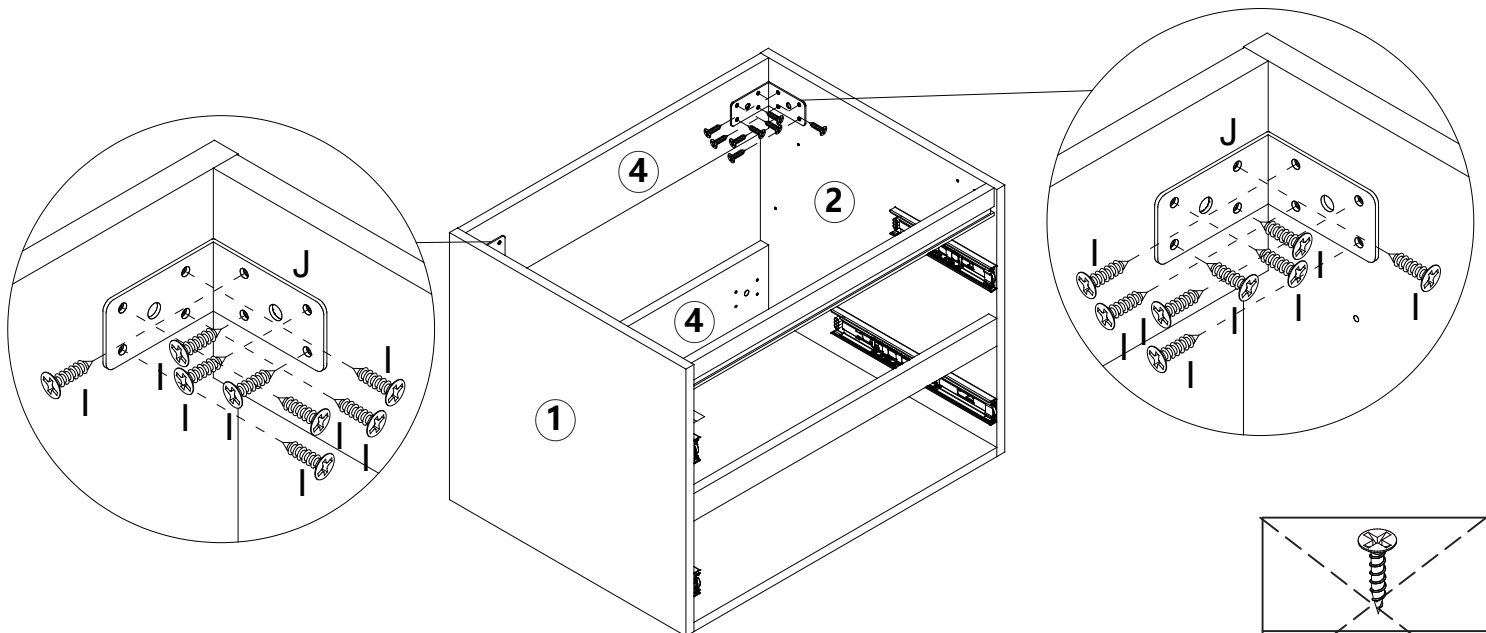

	
C x 8pcs	B x 3pcs

7



	
I x 16pcs	J x 2pcs

8

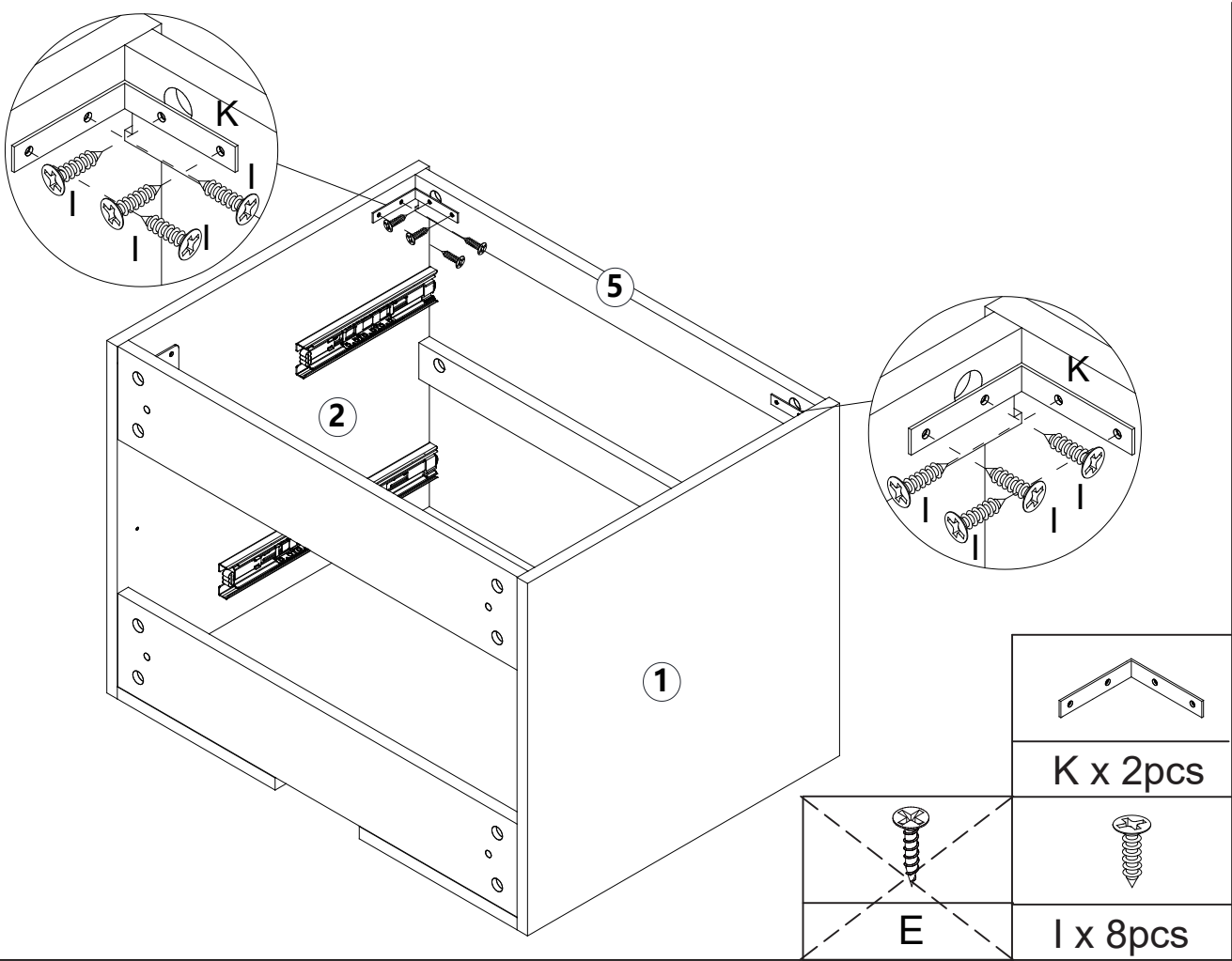

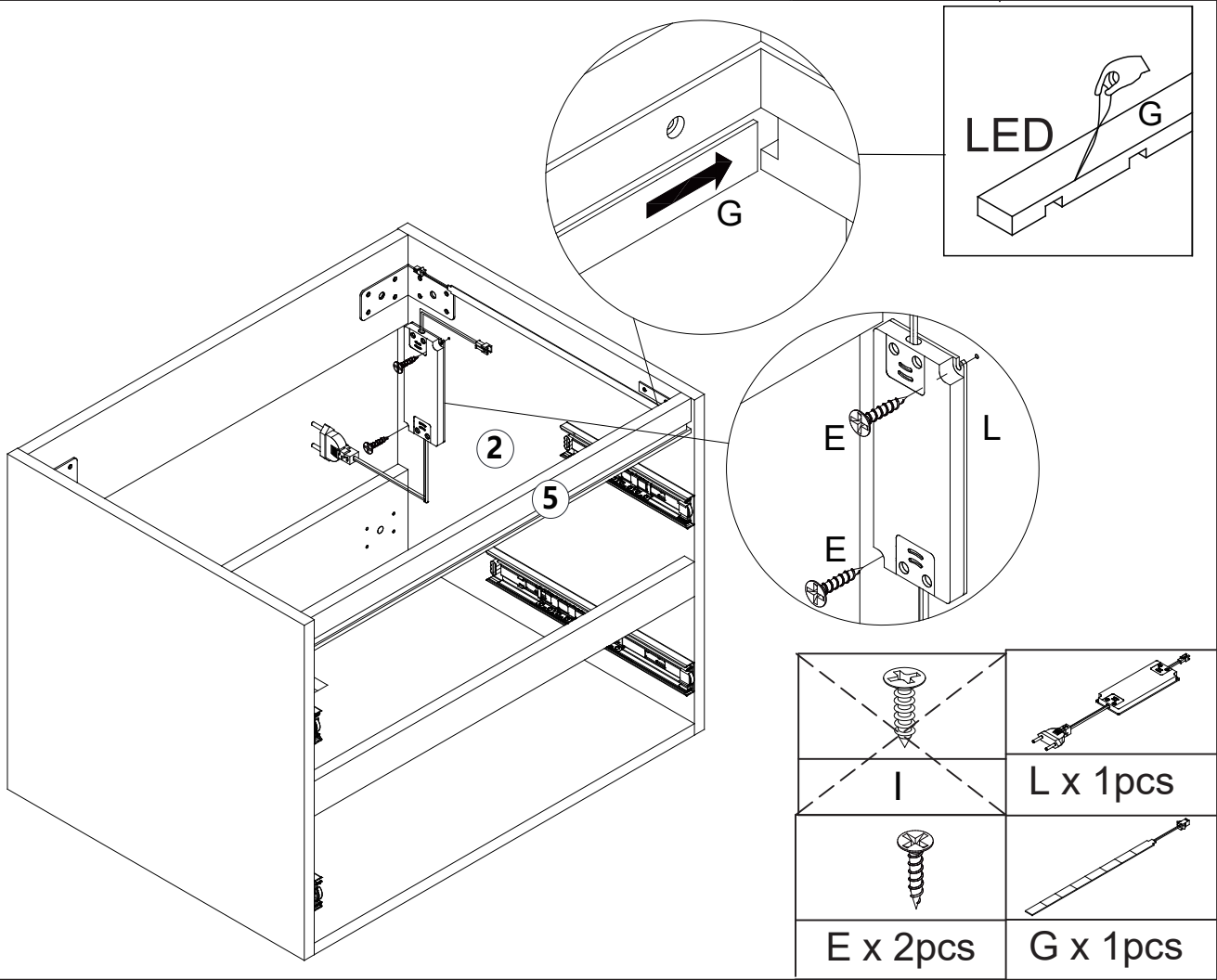

9

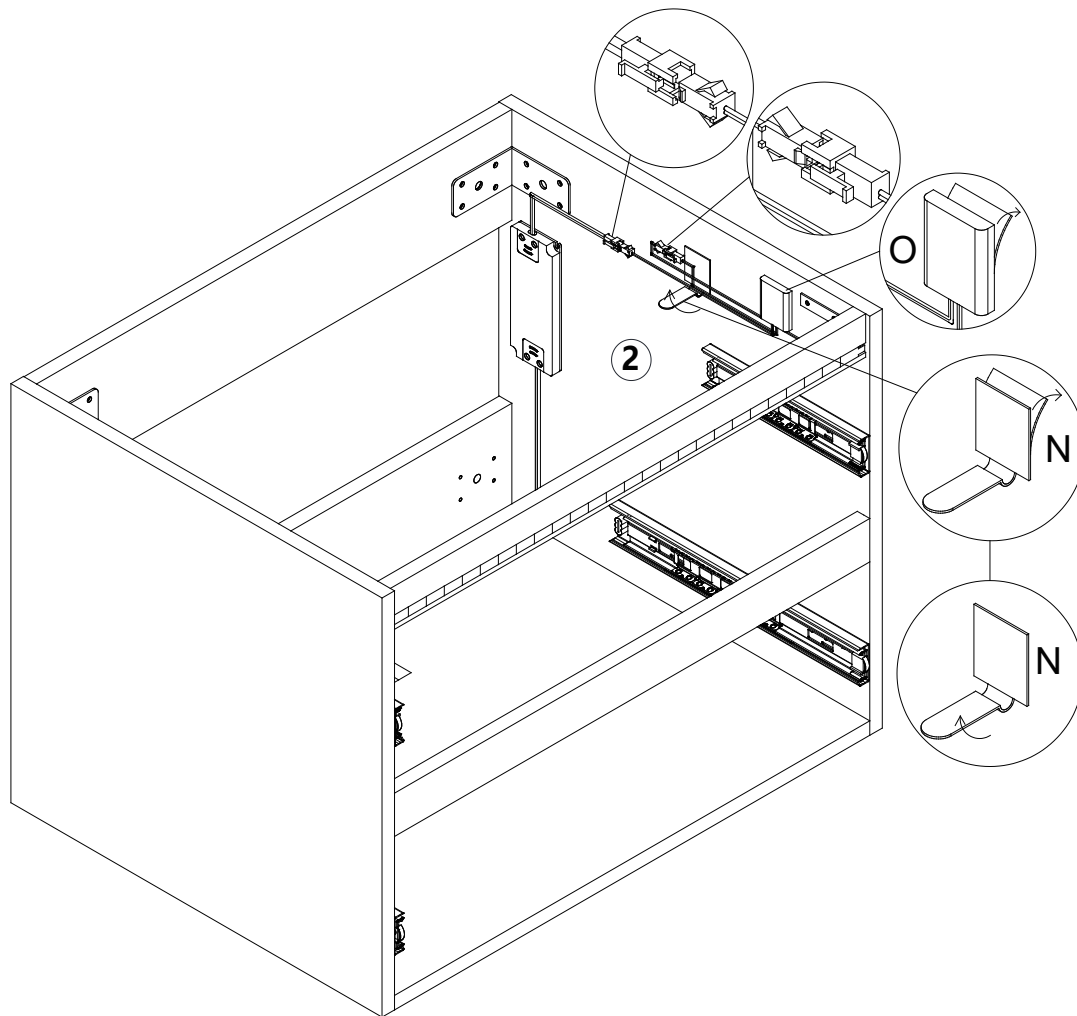

10

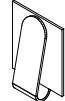

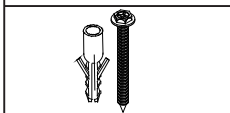
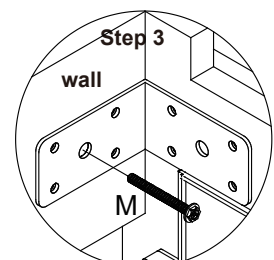
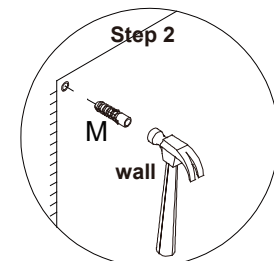
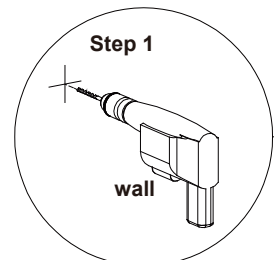
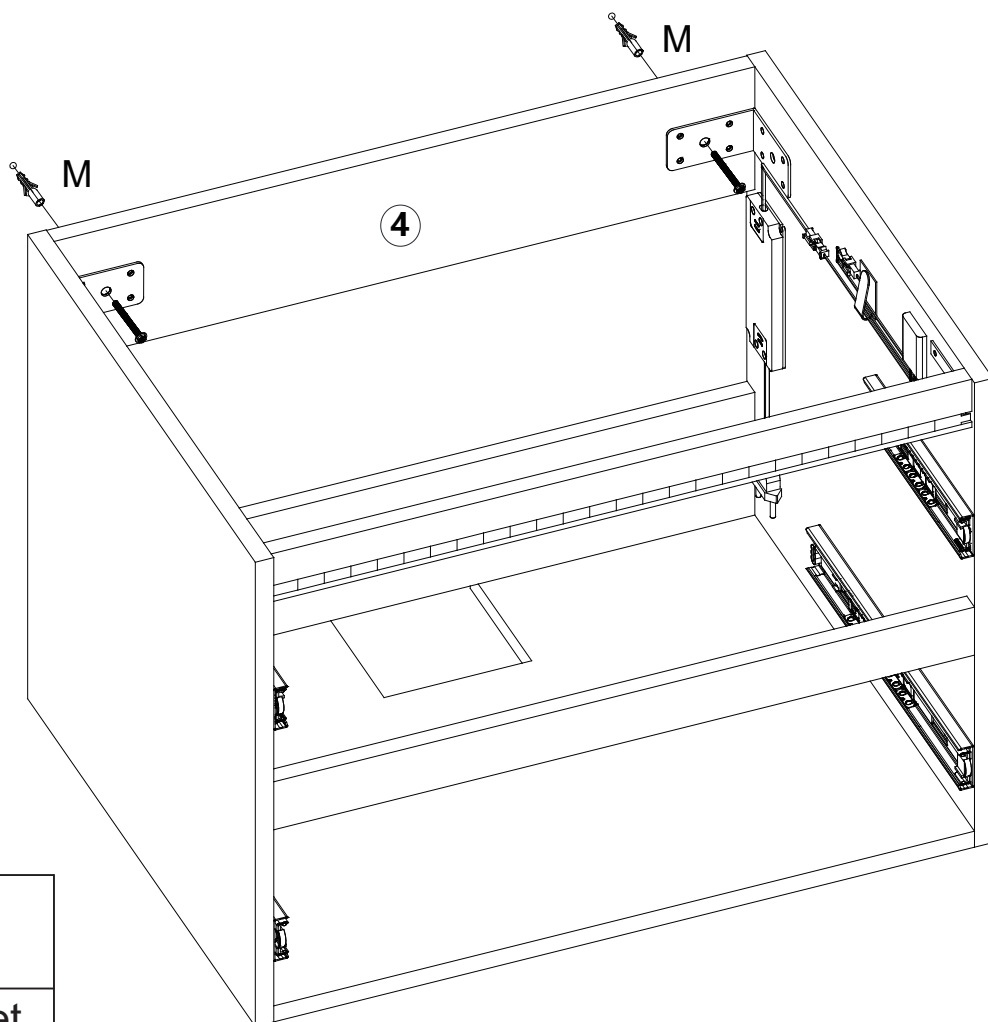

N x 1pcs

O x 1pcs

11

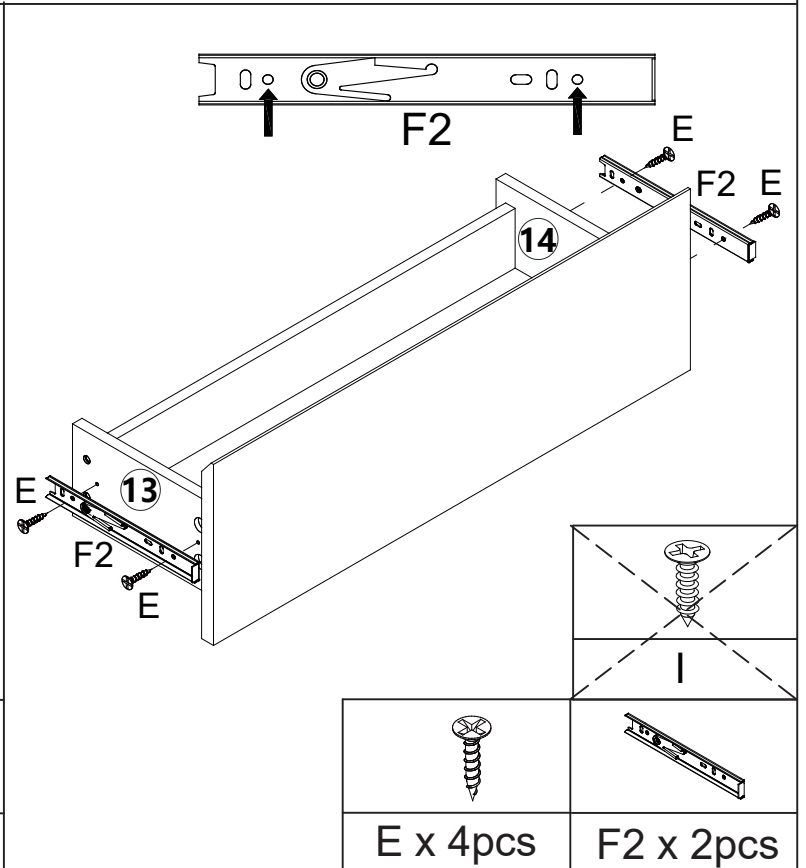
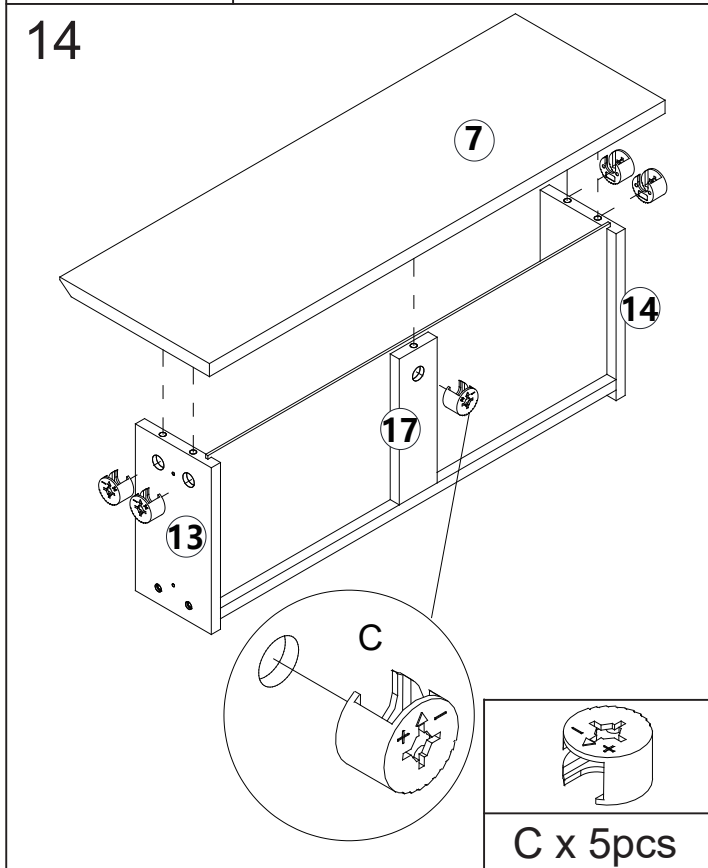
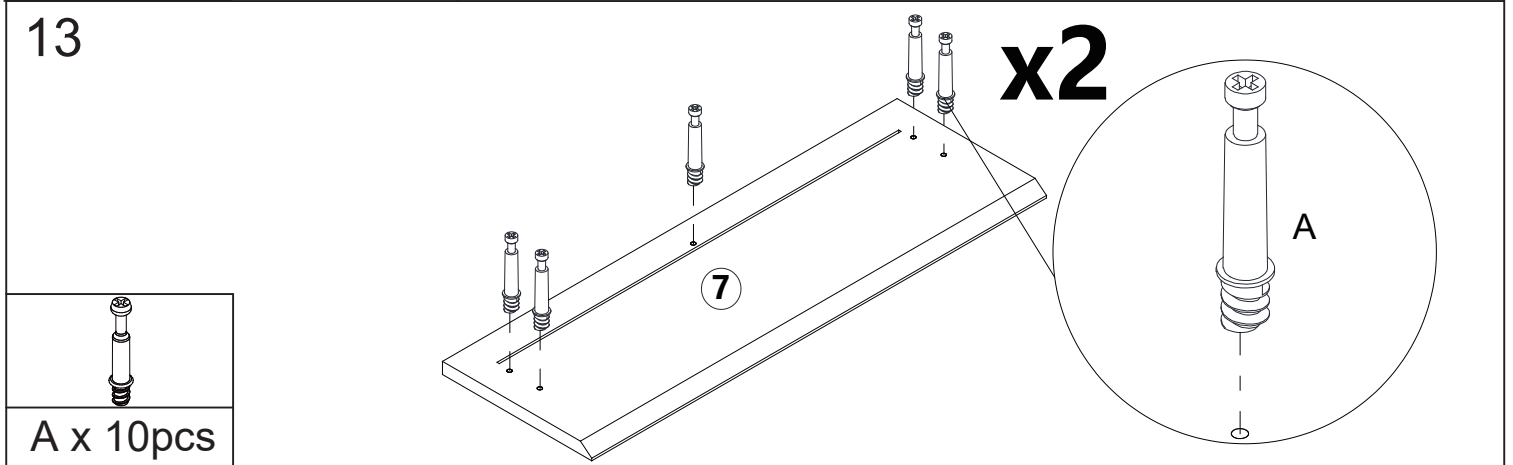
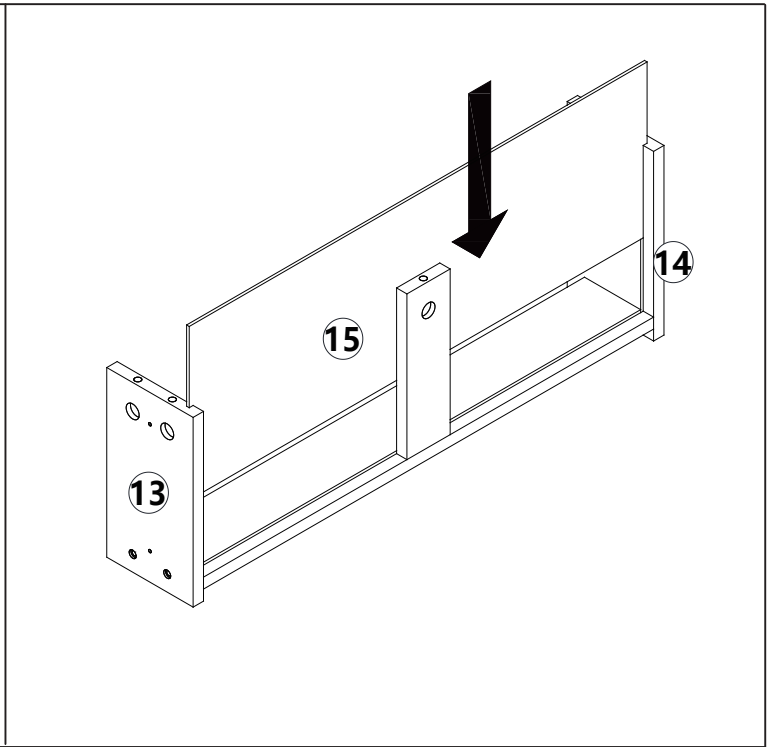
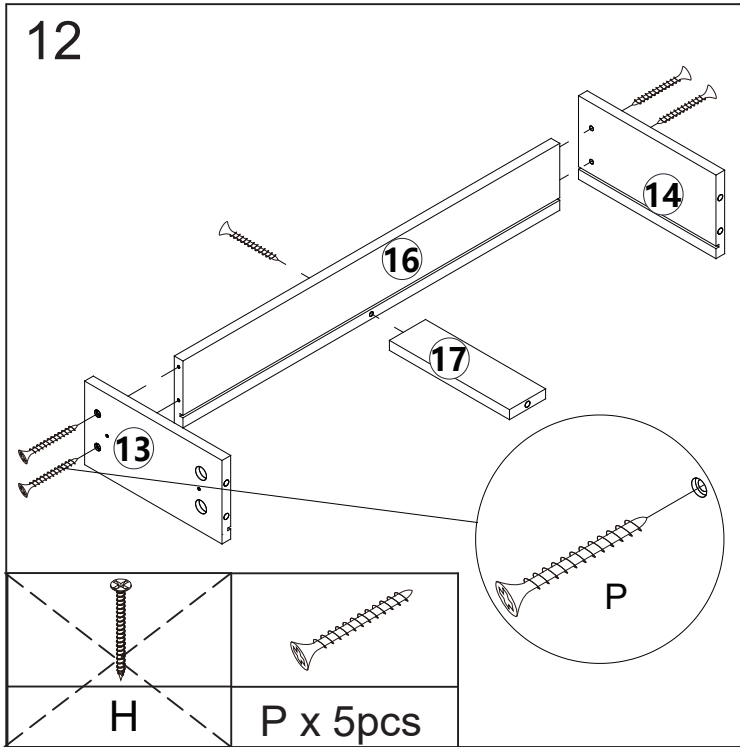

M x 2set



15

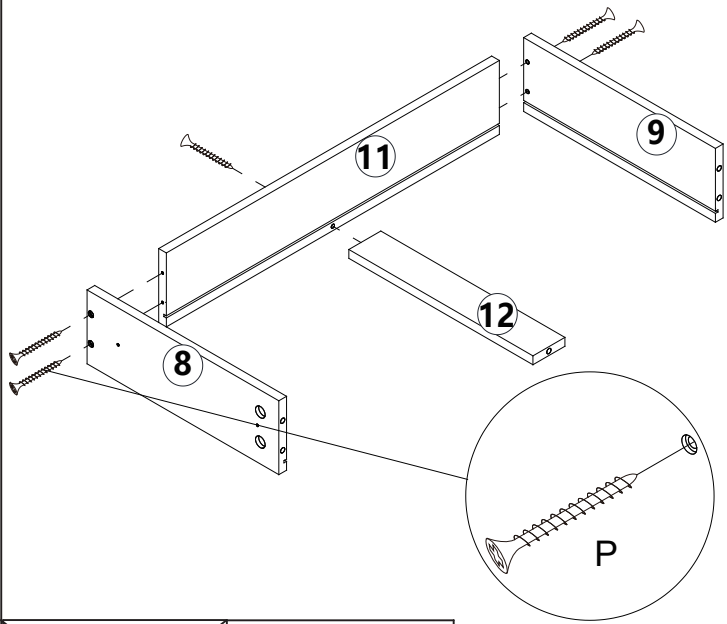

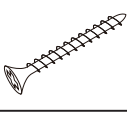
	
H	P x 5pcs

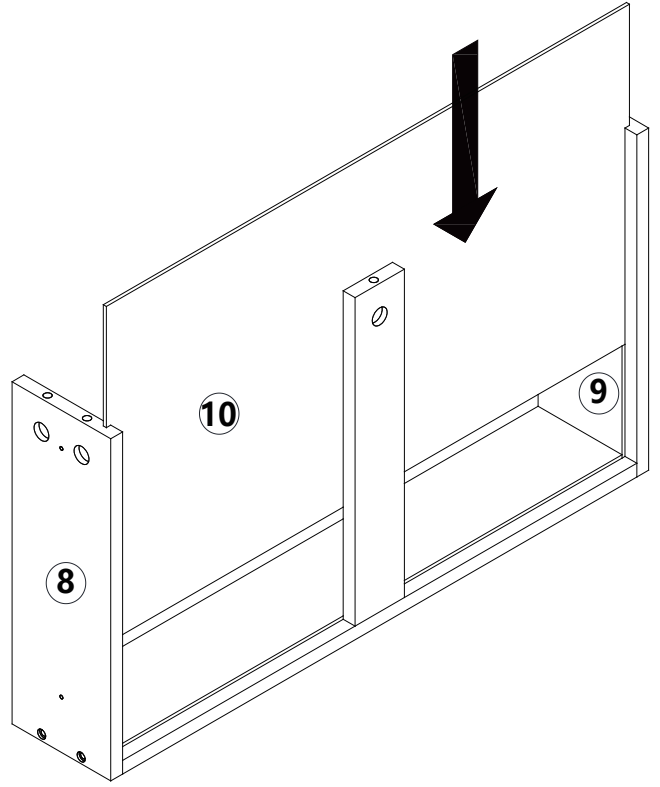

16

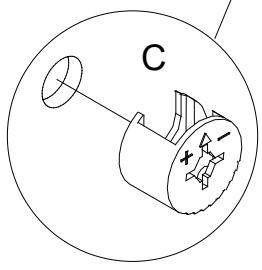
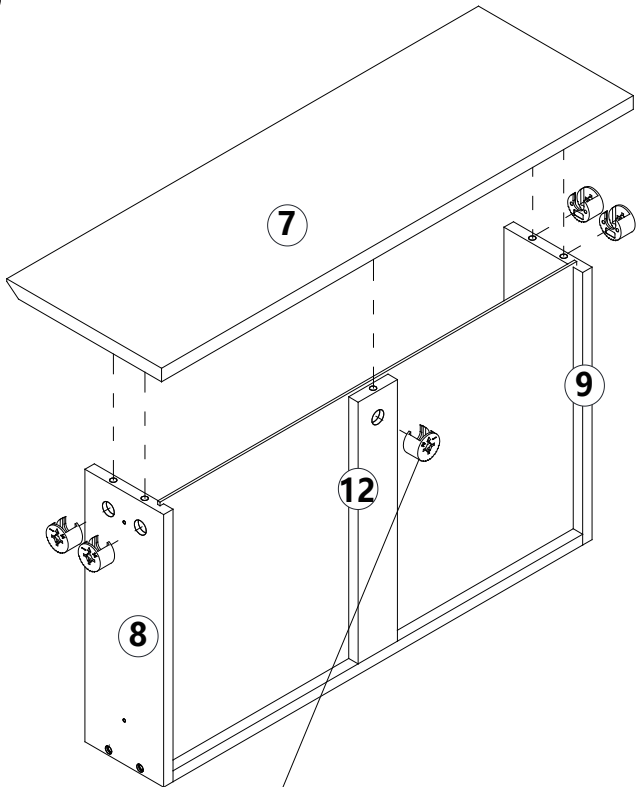

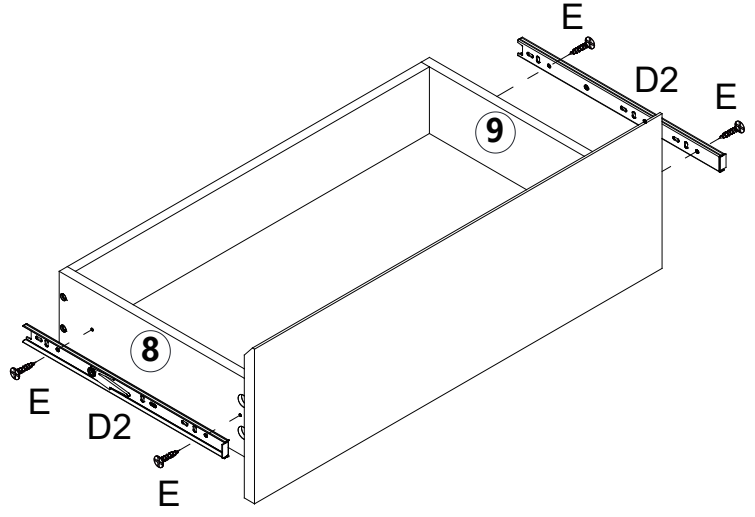
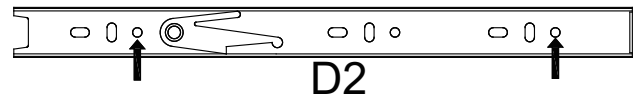

C x 5pcs

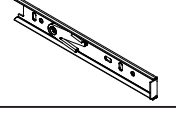

	
E x 4pcs	D2 x 2pcs

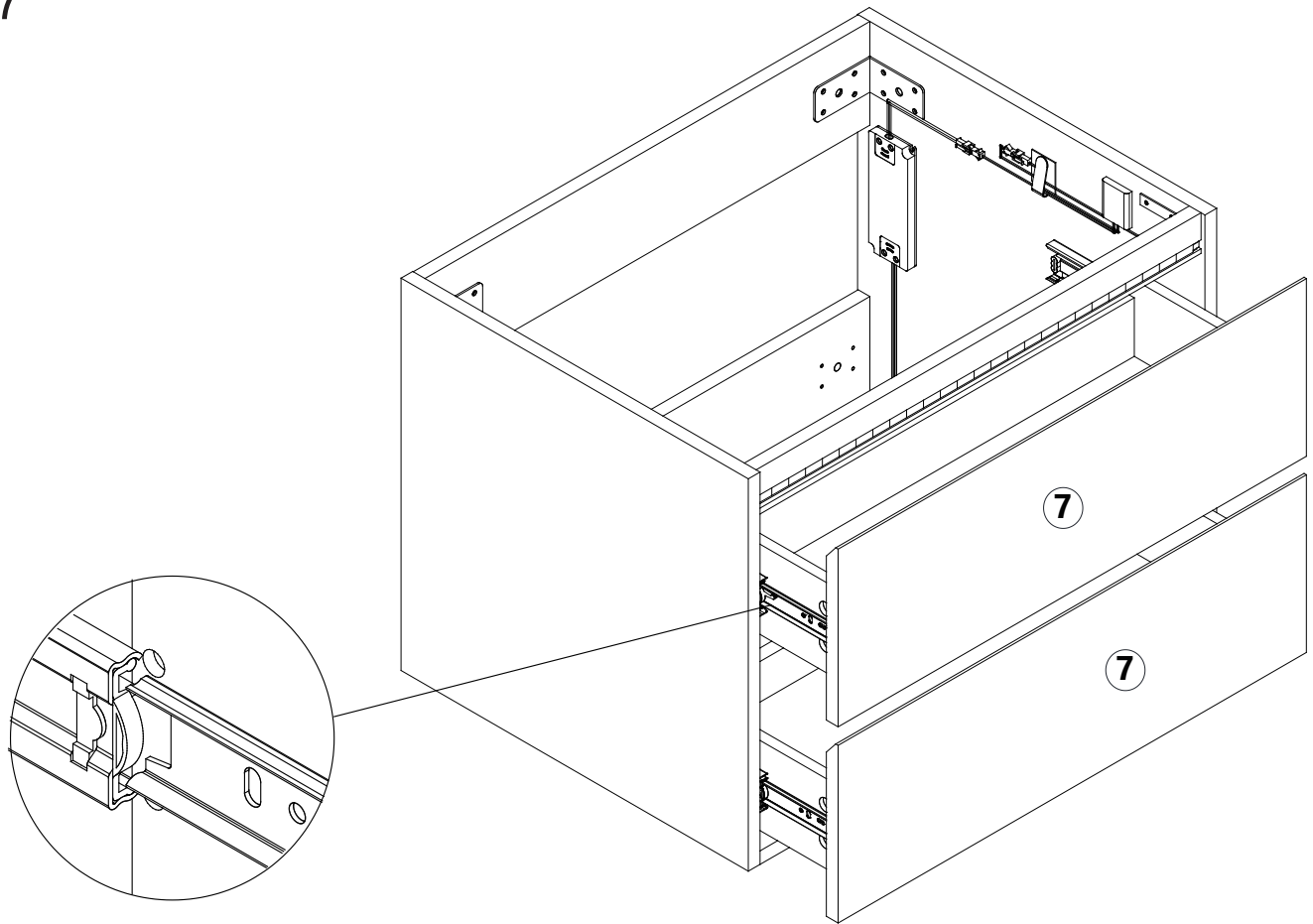
17



18

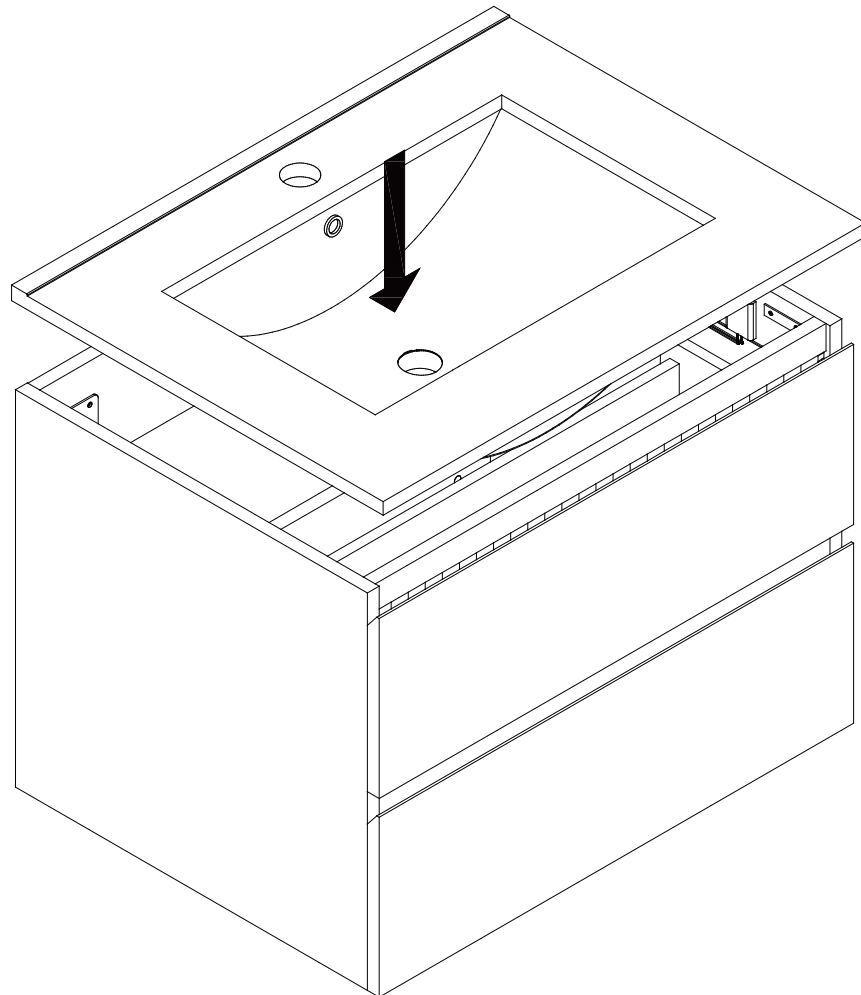

19

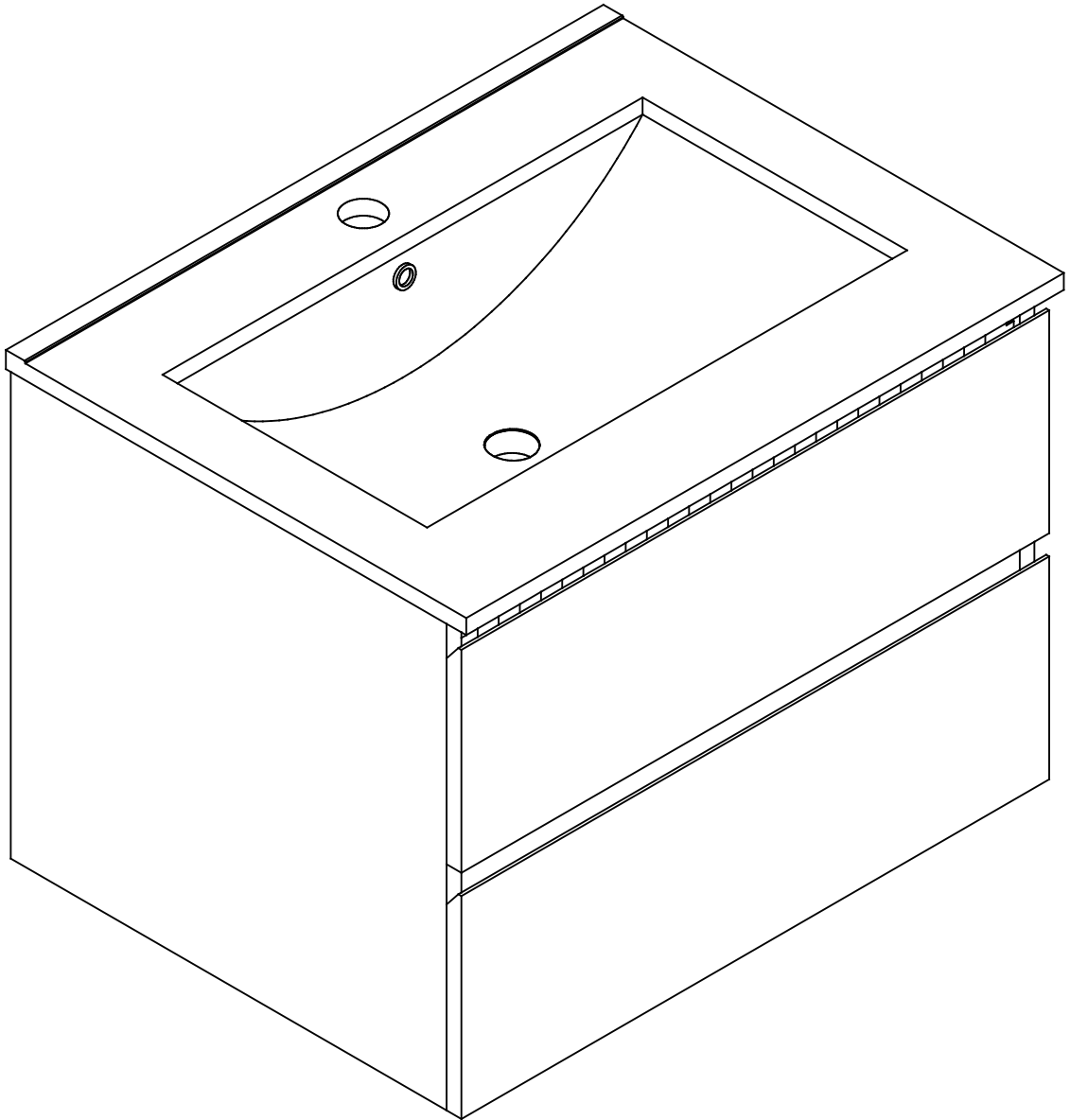

AOC-Testing



Certificate of Compliance

Certificate Number: AOC220115001S

Applicant : Zhongshan guzhen Laili Lighting Electric Appliance Factory

Address : South of 2nd Floor, No. 6, North Lane 2, East Hua 'an Road,
Caosan Pioneer Park, Guzhen Town, Zhongshan City,
Guangdong Province, China

Manufacturer : Zhongshan guzhen Laili Lighting Electric Appliance Factory

Address : South of 2nd Floor, No. 6, North Lane 2, East Hua 'an Road,
Caosan Pioneer Park, Guzhen Town, Zhongshan City,
Guangdong Province, China

Factory : Zhongshan guzhen Laili Lighting Electric Appliance Factory

Address : South of 2nd Floor, No. 6, North Lane 2, East Hua 'an Road,
Caosan Pioneer Park, Guzhen Town, Zhongshan City,
Guangdong Province, China

Product : LED DRIVER

Trade Mark : N/A

Model(s) : See model list

Parameters : 100-265 V~, 50 Hz, 48 W, 0.28 A, Class II, Independent SELV,
ta:40 °C, tc: 85 °C

The submitted products have been tested by us with the listed standards and found in compliance with the following European Directives:

The LVD Directive 2014/35/EU
IEC 61347-2-13:2014+A1:2016;

IEC 61347-1:2015+A1:2017

The tests were performed in normal operation mode. The test results apply only to the particular sample tested and to the specific tests carried out. This certificate applies specifically to the sample investigated in our test reference number only.

The CE markings as shown below can be affixed on the product after preparation of necessary technical documentation.

Other relevant Directives have to be observed.

CE

Robm
Manager
January 19, 2022

Shenzhen AOCE Electronic Technology Service Co., Ltd
Room 202, 2nd Floor, No.12th Building of Xinhe Tongfuyu Industrial Park, Fuhai Street,
Baoan District, Shenzhen, Guangdong, China
Tel: (86)755-29799330 Fax: (86)755-23705230
Http://www.aoc-cert.com Email: postmaster@aoc-cert.com

**ANNEX 1****Model list**

JNCE-48W-01	JNCE-48W-02	JNCE-48W-03
JNCE-48W-01	JNCE-36W-02	JNCE-36W-03
JNCE-24W-01	JNCE-24W-02	JNCE-24W-03
JNCE-12W-01	JNCE-12W-02	JNCE-12W-03
JNCCB-48WJD-A	JNCCB-48WJD-B	JNCCB-48WJD-C
JNCCB-36WJD-A	JNCCB-36WJD-B	JNCCB-36WJD-C
JNCCB-24WJD-A	JNCCB-24WJD-B	JNCCB-24WJD-C
JNCCB-12WJD-A	JNCCB-12WJD-B	JNCCB-12WJD-C
JNCCB-48W-A	JNCCB-48W-B	JNCCB-48W-C
JNCCB-36W-A	JNCCB-36W-B	JNCCB-36W-C
JNCCB-24W-A	JNCCB-24W-B	JNCCB-24W-C
JNCCB-12W-A	JNCCB-12W-B	JNCCB-12W-C

CE

Shenzhen AOCE Electronic Technology Service Co., Ltd
Room 202, 2nd Floor, No.12th Building of Xinhe Tongfuyu Industrial Park, Fuhai Street,
Baoan District, Shenzhen, Guangdong, China
Tel: (86)755-29799330 Fax: (86)755-23705230
Http://www.aoc-cert.com Email: postmaster@aoc-cert.com



TEST REPORT

Applicant : Shenzhen xu xing technology co., LTD
Applicant Address : Floor 3, building C, Huaze hi tech Industrial Park, Shiyan street, Bao'an District, Shenzhen
Manufacturer : Shenzhen xu xing technology co., LTD
Manufacturer Address : Floor 3, building C, Huaze hi tech Industrial Park, Shiyan street, Bao'an District, Shenzhen

Report on the submitted samples said to be:

Sample Name(s) : Two tone light strip
Trade Mark : N/A
Tested Model No. : 6X2835-WY
Model List## : 8X2835-WY
Sample Received Date : December 24, 2024
Testing Period : December 24, 2024 ~ December 27, 2024
Date of Report : December 27, 2024
Testing Location : 901, No.40 Building, Xialang Industrial Zone, Heshuikou Community, Matian Street, Guangming District, Shenzhen, Guangdong, China
Results : Please refer to next page(s).

TEST REQUEST	CONCLUSION
As specified by client, based on the performed tests on submitted sample, the result of Lead(Pb), Cadmium(Cd), Mercury(Hg), Hexavalent Chromium(Cr(VI)), PBBs, PBDEs, Dibutyl Phthalate(DBP), Butylbenzyl Phthalate(BBP), Di-2-ethylhexyl Phthalate(DEHP) and Diisobutyl phthalate(DIBP) content comply with the limits set by RoHS Directive 2011/65/EU with amendment (EU) 2015/863.	PASS

##=According to client's declaration, tested material would be produced as relevant product(s).

Signed for and on behalf of LCS

Terry Luo

TRF-4-R-027 A/0



Shenzhen LCS Compliance Testing Laboratory Ltd.
 Add: 901, No.40 Building, Xialang Industrial Zone, Heshuikou Community, Matian Street, Guangming District, Shenzhen, Guangdong, China
 Tel: +(86) 0755-82591330 | E-mail: webmaster@lcs-cert.com | Web: www.lcs-cert.com
 Scan code to check authenticity

**A. EU RoHS Directive 2011/65/EU and its amendment directives**

Test method: Refer to IEC 62321-3-1:2013, Screening by X-ray Fluorescence Spectroscopy (XRF).

Test result(s):

Sample No.	Sample Description	Screening Result(s)						Date of sample submission/ Resubmission
		Cd	Pb	Hg	Cr [▼]	Br [▼]		
						PBBs	PBDEs	
1	Red plastic thread	BL	BL	BL	BL	BL	BL	2024-12-24
2	White plastic thread	BL	BL	BL	BL	BL	BL	2024-12-24
3	Black plastic thread	BL	BL	BL	BL	BL	BL	2024-12-24
4	Silver wire	BL	BL	BL	BL	/	/	2024-12-24
5	Black plastic sheet	BL	BL	BL	BL	BL	BL	2024-12-24
6	Silver metal needle	BL	BL	BL	BL	/	/	2024-12-24
7	Orange lamp bead	BL	BL	BL	BL	BL	BL	2024-12-24
8	Chip resistor	BL	BL	BL	BL	BL	BL	2024-12-24
9	Yellow lamp bead	BL	BL	BL	BL	BL	BL	2024-12-24
10	Tin solder	BL	BL	BL	BL	/	/	2024-12-24
11	White FPC	BL	BL	BL	BL	BL	BL	2024-12-24

Note:

- Results were obtained by XRF for primary screening, and further chemical testing by ICP(for Cd, Pb, Hg), UV-Vis(for Cr(VI)) and GC-MS(for PBBs, PBDEs) are recommended to be performed, if the concentration exceeds the below warning value according to IEC 62321-3-1:2013(Unit: mg/kg).

Element	Polymers	Metals	Composite material
Cd	$BL \leq (70-3\sigma) < X < (130+3\sigma) \leq OL$	$BL \leq (70-3\sigma) < X < (130+3\sigma) \leq OL$	$LOD < X < (150+3\sigma) \leq OL$
Pb	$BL \leq (700-3\sigma) < X < (1300+3\sigma) \leq OL$	$BL \leq (700-3\sigma) < X < (1300+3\sigma) \leq OL$	$BL \leq (500-3\sigma) < X < (1500+3\sigma) \leq OL$
Hg	$BL \leq (700-3\sigma) < X < (1300+3\sigma) \leq OL$	$BL \leq (700-3\sigma) < X < (1300+3\sigma) \leq OL$	$BL \leq (500-3\sigma) < X < (1500+3\sigma) \leq OL$
Cr	$BL \leq (700-3\sigma) < X$	$BL \leq (700-3\sigma) < X$	$BL \leq (500-3\sigma) < X$
Br	$BL \leq (300-3\sigma) < X$	N/A	$BL \leq (250-3\sigma) < X$

Remark:

- BL= Below Limit
 - OL= Over Limit
 - X= The range of needing to do further testing
 - 3σ= The reproducibility of analytical instruments
 - N/A= Not applicable
 - LOD= Detection limit
- The XRF screening test for RoHS elements – The reading may be different to the actual content in the sample be of non-uniformity composition.
 - The maximum permissible limit is quoted from the document RoHS Directive 2011/65/EU with amendment (EU) 2015/863.

TRF-4-R-027 A/0



Shenzhen LCS Compliance Testing Laboratory Ltd.
 Add: 901, No.40 Building, Xialang Industrial Zone, Heshuikou Community, Matian Street, Guangming District, Shenzhen, Guangdong, China
 Tel: +(86) 0755-82591330 | E-mail: webmaster@lcs-cert.com | Web: www.lcs-cert.com
 Scan code to check authenticity



4. ▼=For restricted substances PBBs and PBDEs, the results show the total Br content, the restricted substance was Cr(VI), and the results showed the total Cr content.

RoHS Restricted Substances	Maximum Concentration Value (mg/kg) (by weight in homogenous materials)
Cadmium(Cd)	100
Lead(Pb)	1000
Mercury(Hg)	1000
Hexavalent Chromium(Cr(VI))	1000
Polybrominated biphenyls(PBBs)	1000
Polybrominated diphenylethers(PBDEs)	1000
Dibutyl Phthalate(DBP)	1000
Butylbenzyl Phthalate(BBP)	1000
Di-(2-ethylhexyl) Phthalate(DEHP)	1000
Diisobutyl phthalate(DIBP)	1000

Disclaimers:

This XRF Screening report is for reference purposes only. The applicant shall make its/his/her own judgment as to whether the information provided in this XRF screening report is sufficient for its/his/her purposes. The result shown in this XRF screening report will differ based on various factors, including but not limited to, the sample size, thickness, area, surface flatness, equipment parameters and matrix effect (e.g. plastic, rubber, metal, glass, ceramic etc.). Further wet chemical pre-treatment with relevant chemical equipment analysis are required to obtain quantitative data.



**B. EU RoHS Directive 2011/65/EU with amendment (EU) 2015/863 on DBP, BBP, DEHP & DIBP content**

Test method:

Phthalates(DBP, BBP, DEHP &DIBP) Content:

Refer to IEC 62321-8:2017, by solvent extraction and analysis was performed by gas chromatography-mass spectrometer (GC-MS).

Test result(s):

1) Phthalates(DBP, BBP, DEHP &DIBP)

Tested Item(s)	MDL (mg/kg)	Test Result(s) (mg/kg)		Limit (mg/kg)
		1	2	
Dibutyl Phthalate(DBP) Content	50	N.D.	N.D.	1000
Butylbenzyl Phthalate(BBP) Content	50	N.D.	N.D.	1000
Di-(2-ethylhexyl) Phthalate(DEHP) Content	50	N.D.	N.D.	1000
Diisobutyl phthalate(DIBP) Content	50	N.D.	N.D.	1000

Tested Item(s)	MDL (mg/kg)	Test Result(s) (mg/kg)	Limit (mg/kg)
		3+5+7+8+9+11	
Dibutyl Phthalate(DBP) Content	50	N.D.	1000
Butylbenzyl Phthalate(BBP) Content	50	N.D.	1000
Di-(2-ethylhexyl) Phthalate(DEHP) Content	50	N.D.	1000
Diisobutyl phthalate(DIBP) Content	50	N.D.	1000

Note:

- MDL = Method Detection Limit
- N.D. = Not Detected (<MDL)
- mg/kg= milligram per kilogram=ppm
- According to customer's requirement, only the appointed materials have been tested.

TRF-4-R-027 A/0



Shenzhen LCS Compliance Testing Laboratory Ltd.
Add: 901, No.40 Building, Xialang Industrial Zone, Heshuikou Community, Matian Street, Guangming District, Shenzhen, Guangdong, China
Tel: +(86) 0755-82591330 | E-mail: webmaster@lcs-cert.com | Web: www.lcs-cert.com
Scan code to check authenticity



Test Process

1. Lead(Pb) & Cadmium(Cd): IEC 62321-5:2013

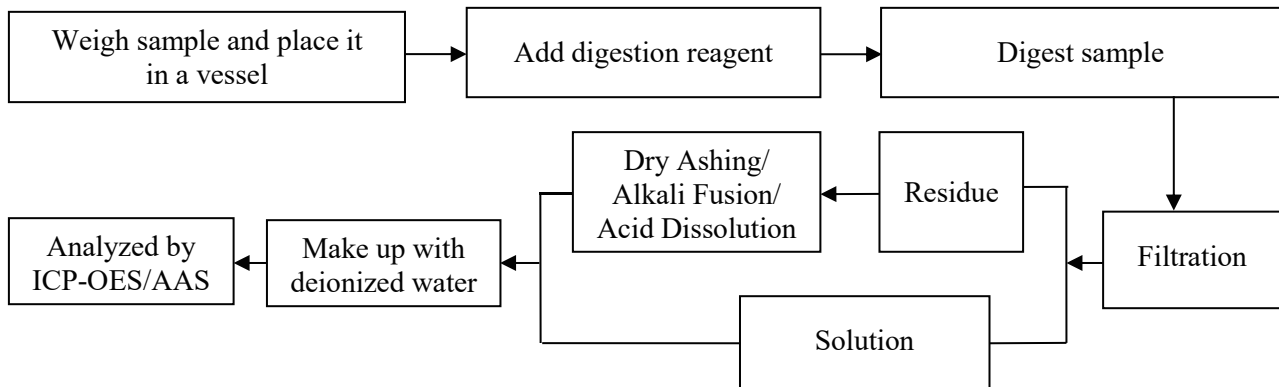

2. Mercury(Hg): IEC 62321-4:2013+AMD1:2017 CSV

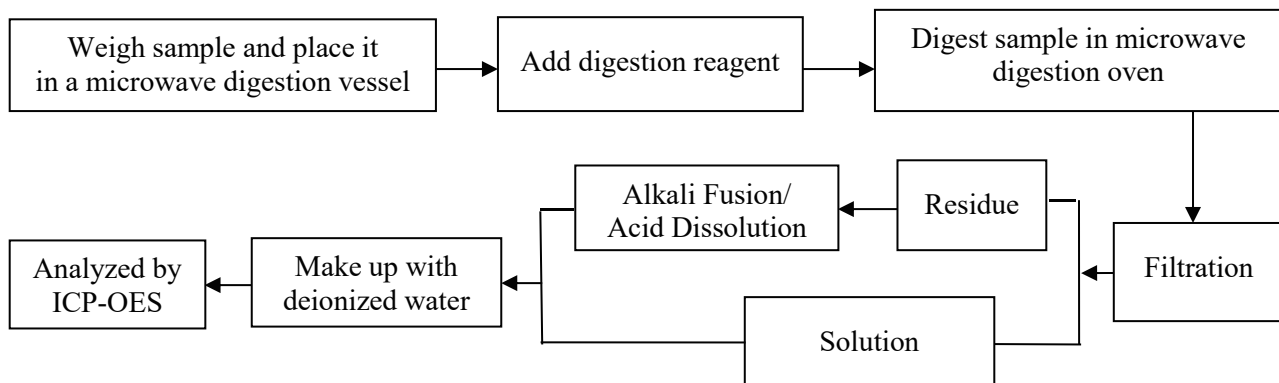

3. Hexavalent Chromium(Cr(VI))

1) IEC 62321-7-2:2017

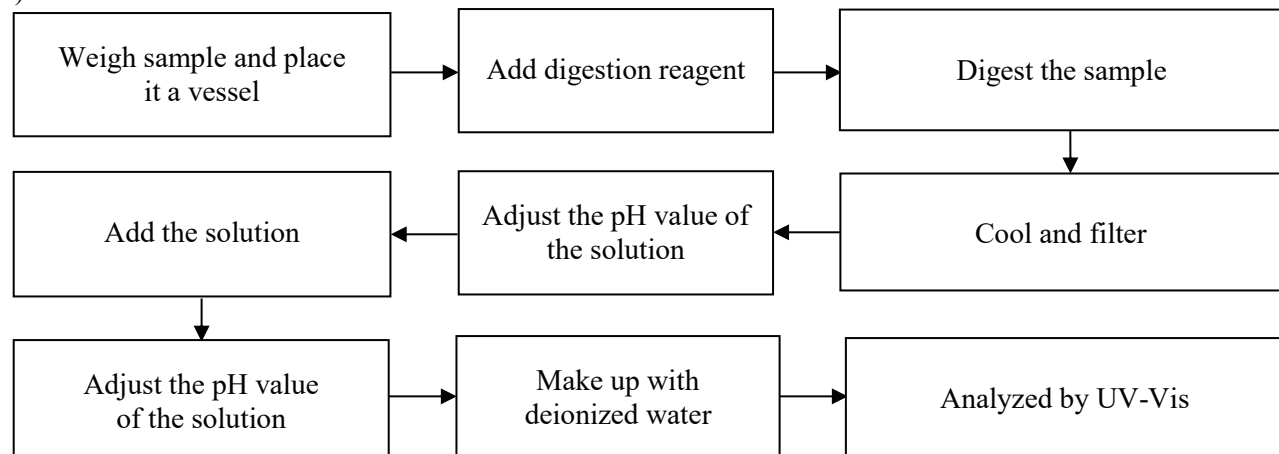



2) IEC 62321-7-1:2015

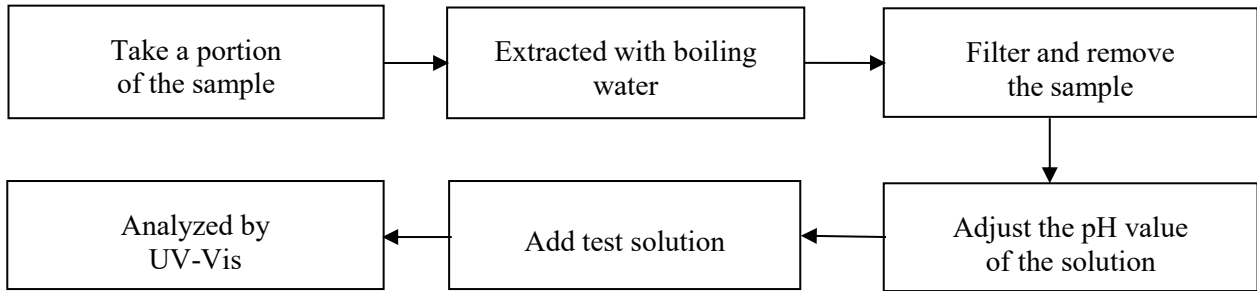

4. Polybrominated Biphenyls(PBBs) & Polybrominated Diphenyl Ethers(PBDEs) : IEC 62321-6:2015

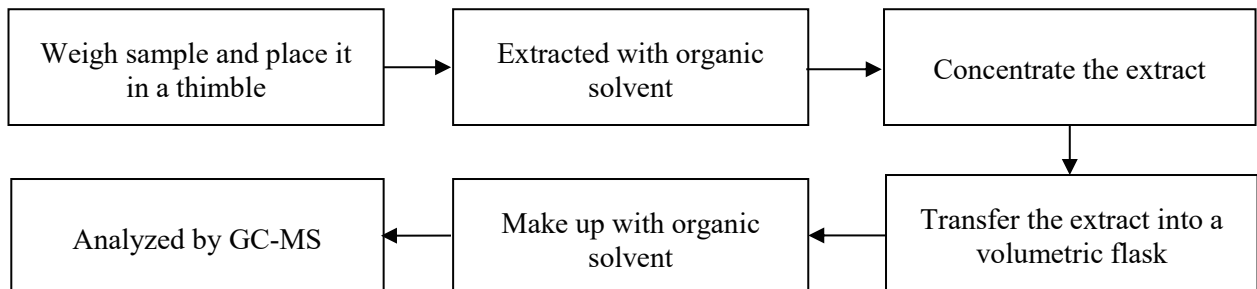

5. Phthalates(DBP, BBP, DEHP & DIBP) : IEC 62321-8:2017

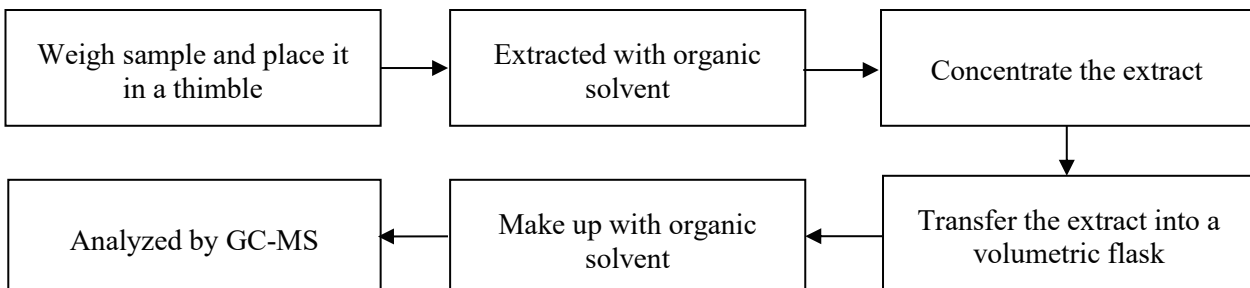

The photo(s) of the sample

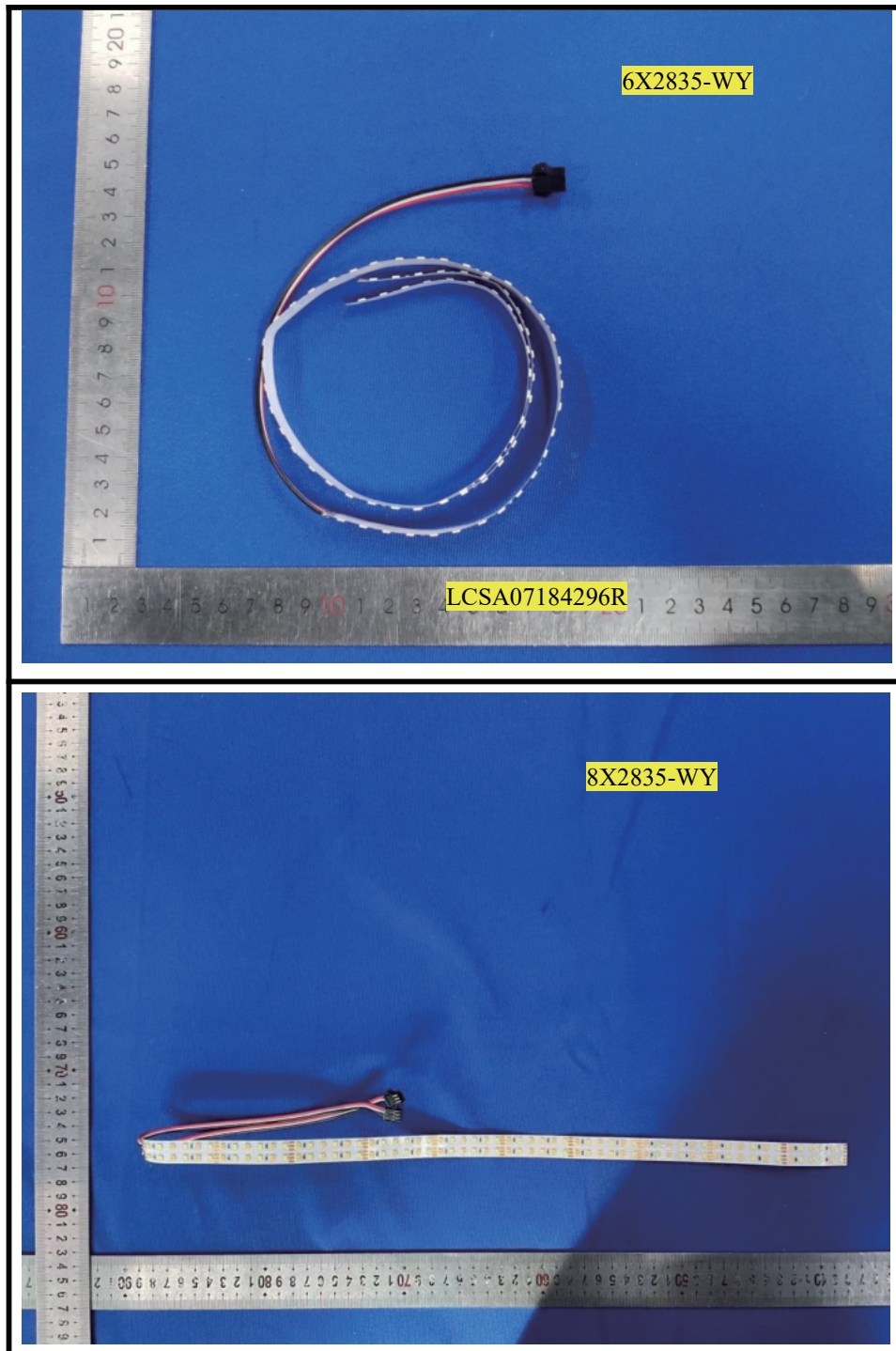

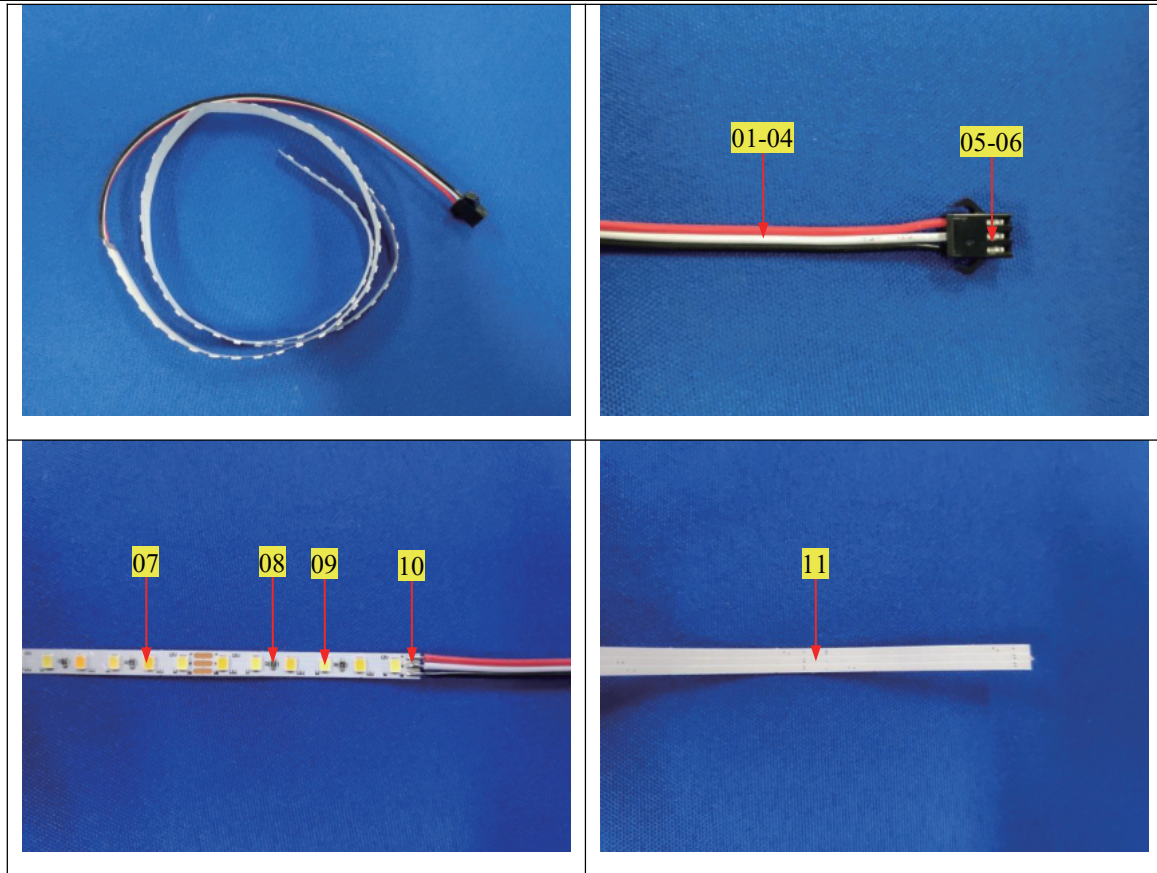
**Statement:**

1. The test report is invalid without the signature of the approver and the special seal for the company's report;
2. The company name, address and sample information shown on the report were provided by the applicant who should be responsible for the authenticity which are not verified by LCS;
3. The test results in this report are only responsible for the tested samples;
4. Without written approval of LCS, this report can't be reproduced except in full;
5. In case of any discrepancy between the corresponding Chinese and English contents in the test report, the Chinese version shall prevail.

*** End of Report ***

