

# GER-MAT7600-N

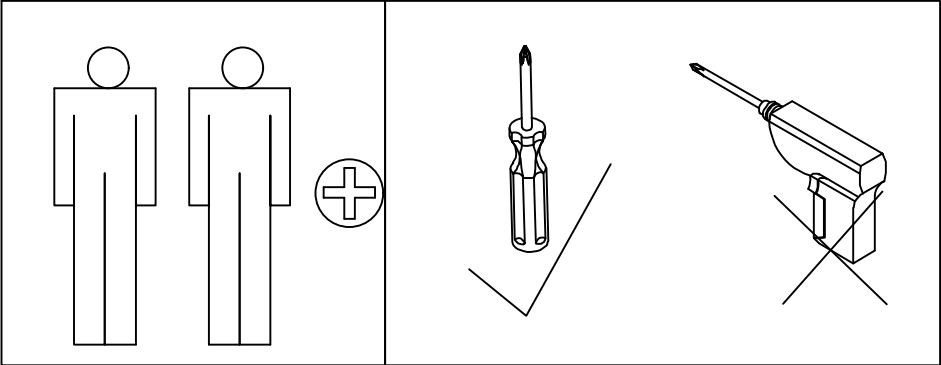
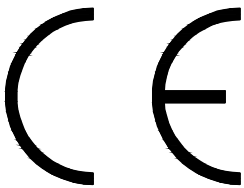
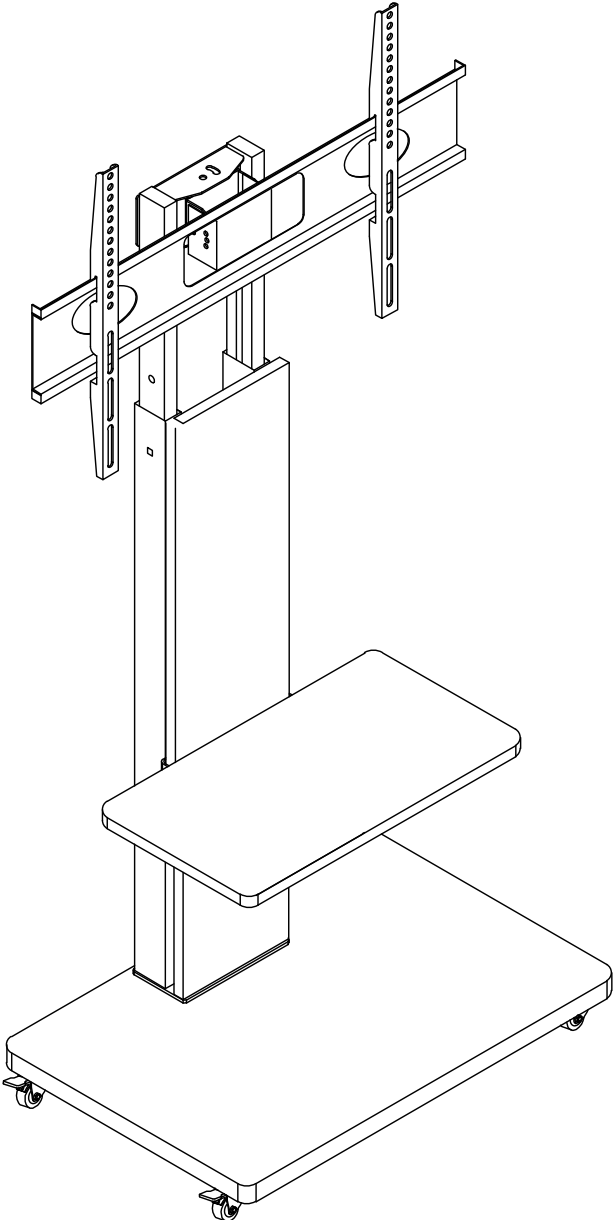

#### EN\_Important Notes

1. Please inspect all components carefully before assembly.
2. During assembly, place the product on a soft, smooth surface (e.g., a carpet) to prevent scratching the parts.
3. Follow the assembly instructions in the correct sequence.
4. Do not fully tighten any screws until the product is completely assembled.
5. Returns are only accepted in the original packaging.  
(\*Assembled products are not eligible for return).

#### FR\_Remarques importantes

1. Veuillez inspecter soigneusement tous les composants avant l'assemblage.
2. Lors de l'assemblage, placez le produit sur une surface lisse et molle (comme un tapis) pour éviter de rayer les pièces.
3. Suivez les instructions d'assemblage dans l'ordre indiqué.
4. Ne serrez aucune vis complètement avant que le produit ne soit entièrement assemblé.
5. Les retours ne sont acceptés que dans l'emballage d'origine.  
(\*Les produits assemblés ne peuvent pas être retournés).

#### ES\_Notas importantes

1. Inspeccione todos los componentes minuciosamente antes del montaje.
2. Durante el montaje, coloque el producto sobre una superficie lisa y blanda (por ejemplo, una alfombra) para evitar que se rayen las piezas.
3. Siga las instrucciones de montaje en el orden correcto.
4. No apriete por completo ningún tornillo hasta que el producto esté completamente montado.
5. Las devoluciones solo se aceptarán en el embalaje original.  
(\*No se admiten devoluciones de productos ya montados).

#### DE\_Wichtige Hinweise



1. Bitte überprüfen Sie vor der Montage alle Komponenten sorgfältig..
2. Stellen Sie das Produkt während der Montage auf eine glatte, weiche Oberfläche (z. B. einen Teppich), um Kratzer an den Teilen zu vermeiden.
3. Befolgen Sie die Montageanleitung in der vorgegebenen Reihenfolge.
4. Ziehen Sie die Schrauben erst vollständig fest, wenn das Produkt vollständig montiert ist.
5. Rücksendungen sind nur in der Originalverpackung möglich.  
(\*Montierte Produkte können nicht zurückgegeben werden).



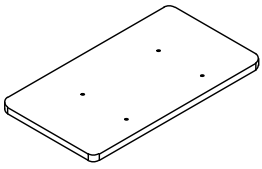
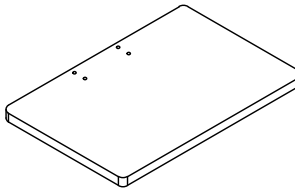
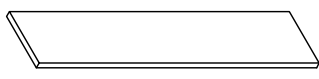
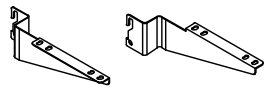

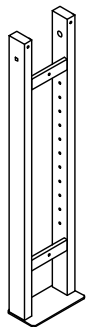
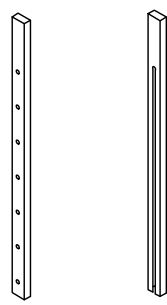
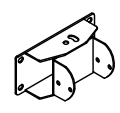
#### IT\_Note importanti

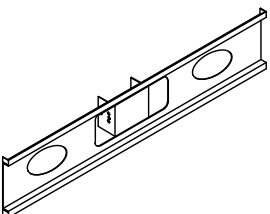

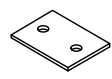
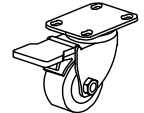
1. Prima dell'assemblaggio, ispezionate attentamente tutti i componenti.
2. Durante l'assemblaggio, posizionate il prodotto su una superficie liscia e morbida (ad esempio, un tappeto) per evitare di graffiare le parti.
3. Seguire le istruzioni di assemblaggio nell'ordine corretto.
4. Non serrare completamente le viti prima che il prodotto sia completamente assemblato.
5. Le resi sono accettati solo nella confezione originale.  
(\*I prodotti assemblati non possono essere restituiti).

<p>① x1</p> 	<p>② x1</p> 	<p>③ x1</p> 	<p>④ x1 (SET)</p>  <p>(Left) (Right)</p>
---	---	--	---

<p>⑤ x4</p> 	<p>⑥ x1 (SET)</p>  <p>(Left) (Right)</p>	<p>⑦ x1</p> 
---	---	---

<p>⑧ x1</p> 	<p>⑨ x2</p> 	<p>⑩ x2</p> 	<p>⑪ x4</p> 
---	---	--	---

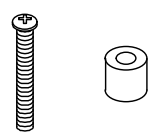
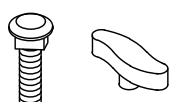
<p>A x3</p> 	<p>B x6</p>  <p>M6*12mm</p>	<p>C x8</p>  <p>M6*8mm</p>	<p>D x16</p>  <p>ST3.5*14mm</p>	<p>E x4</p>  <p>M8*40mm</p>
---	--	---	--	--

<p>F x2</p>  <p>M6*35mm</p>	<p>G x2</p>  <p>G1 G2</p> <p>M8*30mm</p>	<p>H x2</p> 		
--	---	---	--	--

1

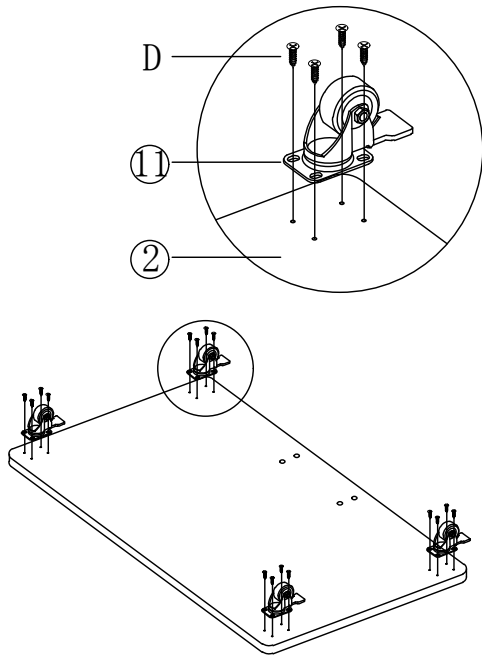

2

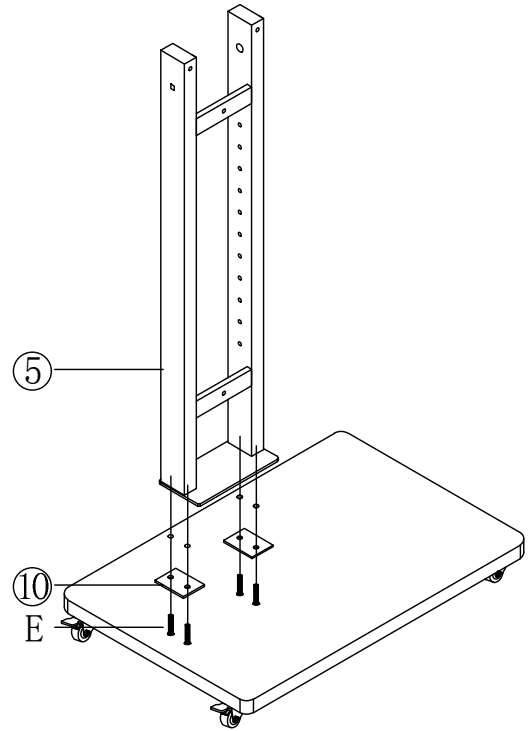

3

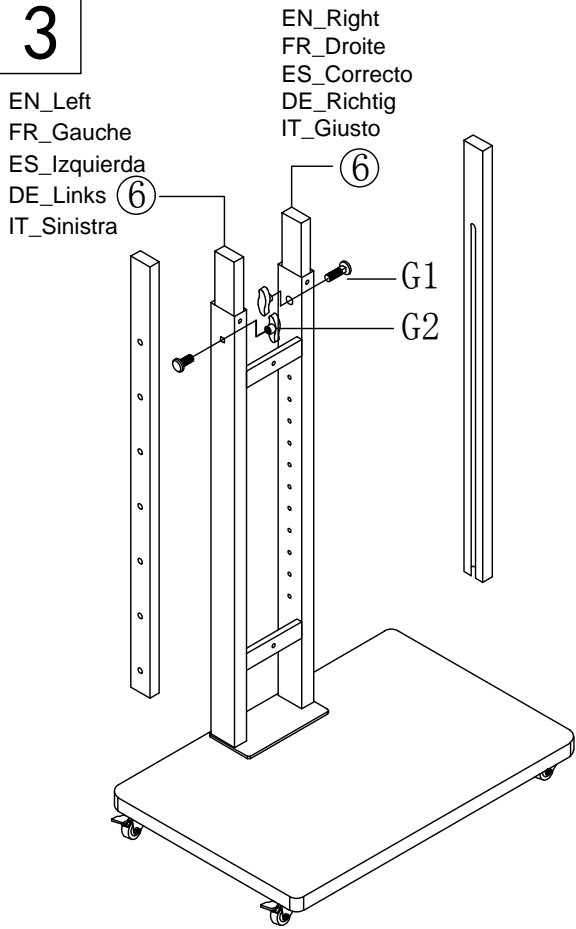

EN\_Left  
FR\_Gauche  
ES\_Izquierda  
DE\_Links  
IT\_Sinistra

EN\_Right  
FR\_Droite  
ES\_Correcto  
DE\_Richtig  
IT\_Giusto

6

G1  
G2

4

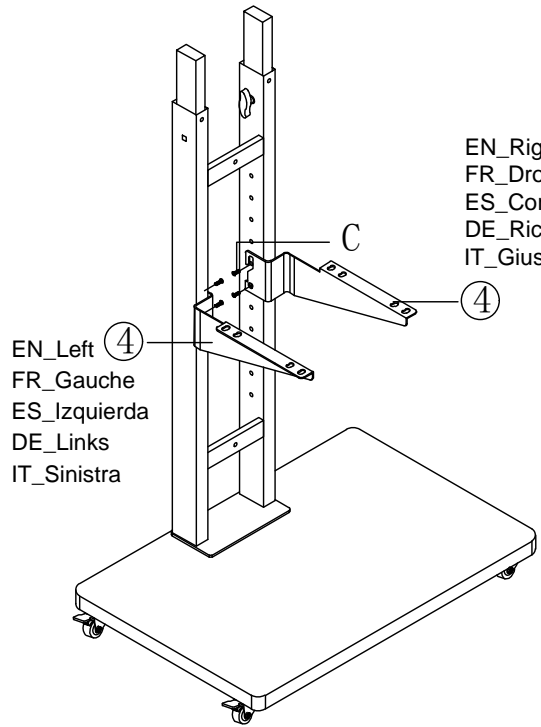

EN\_Left 4  
FR\_Gauche  
ES\_Izquierda  
DE\_Links  
IT\_Sinistra

EN\_Right  
FR\_Droite  
ES\_Correcto  
DE\_Richtig  
IT\_Giusto

4

5

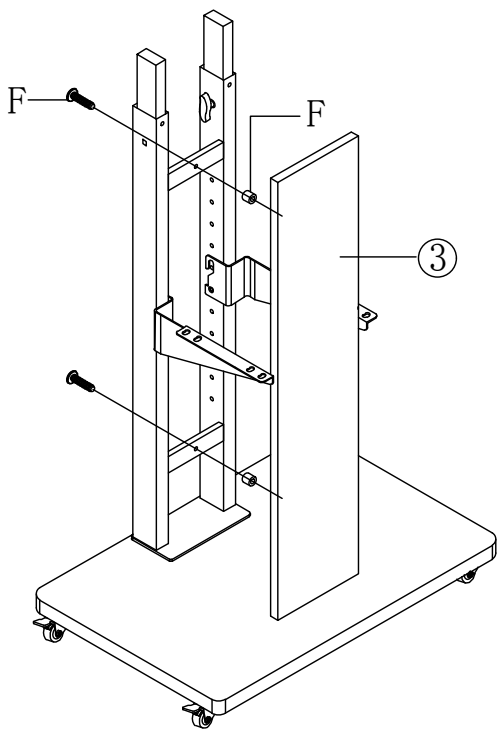

6

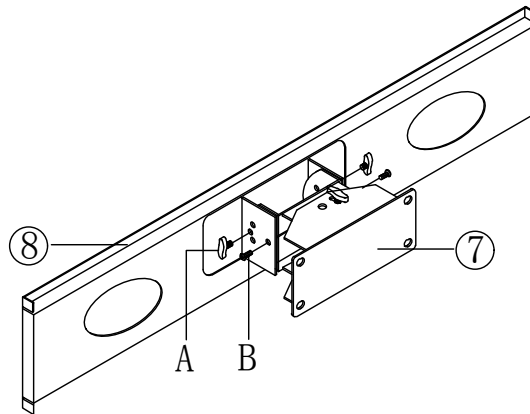

7

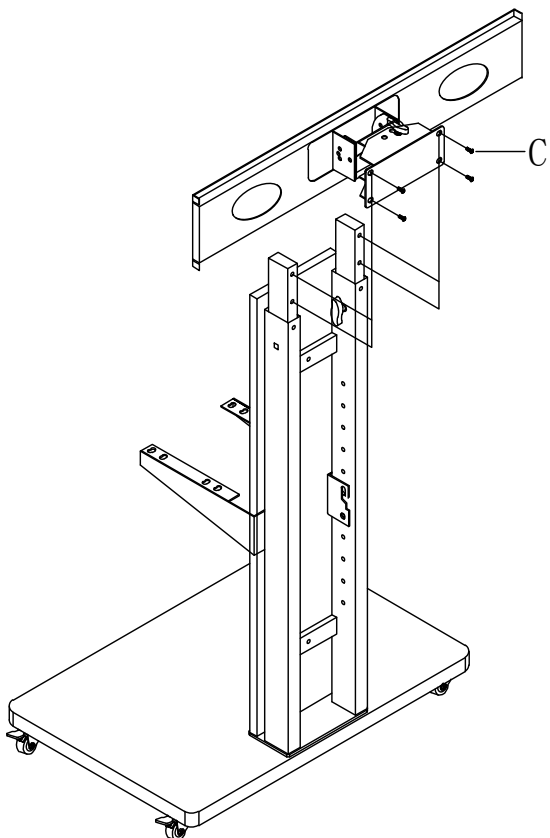

8

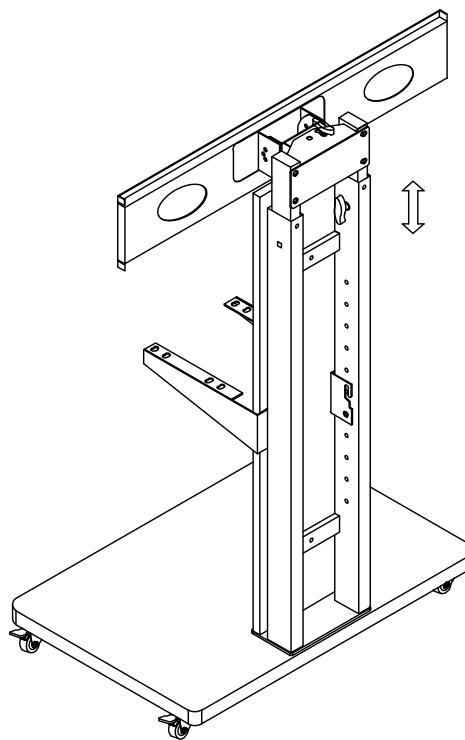

9

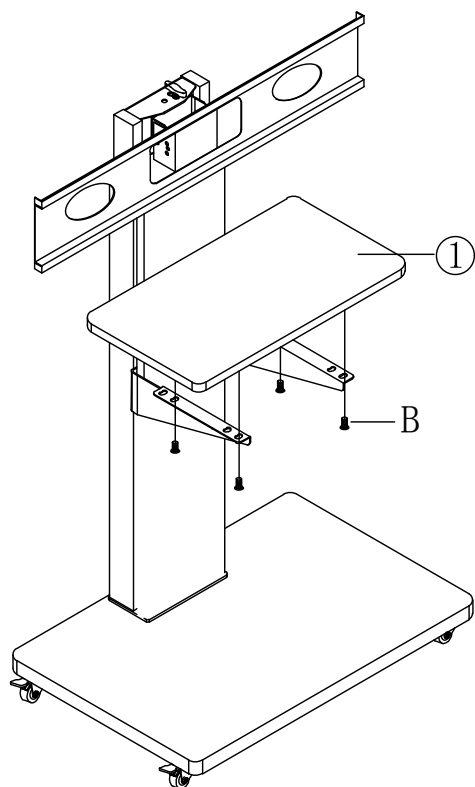

10

EN\_Please be careful not to drop the TV.  
 FR\_Veuillez à ne pas faire tomber le téléviseur.  
 ES\_Tenga cuidado de no dejar caer el televisor.  
 DE\_Achten Sie darauf, den Fernseher nicht fallen zu lassen.  
 IT\_Prestare attenzione a non far cadere il televisore.

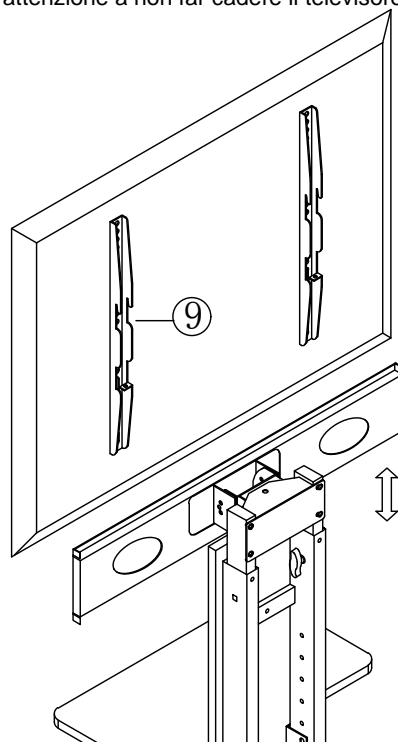

11

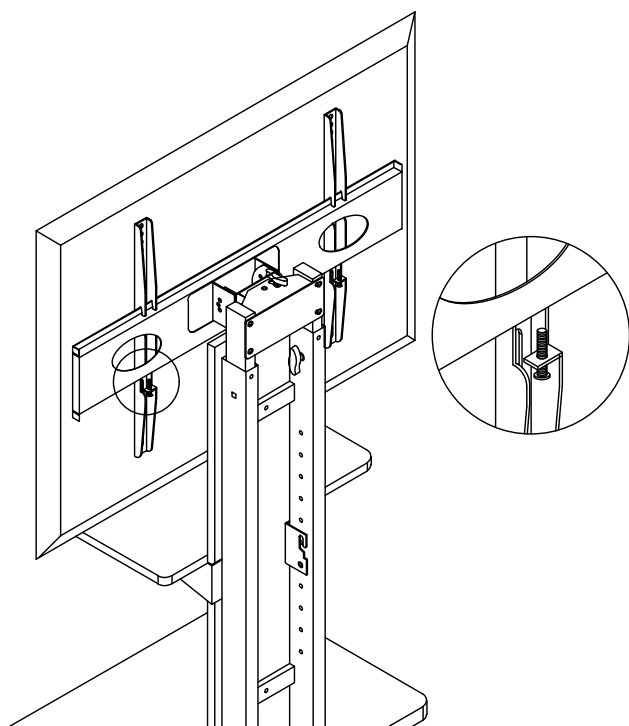

12

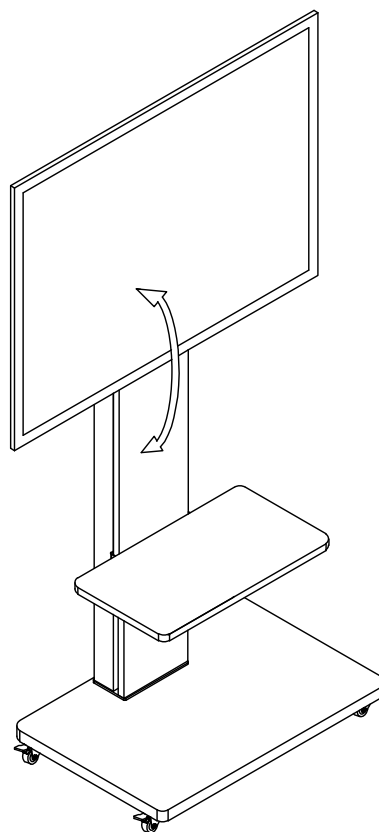

EN\_Angle adjustment  
FR\_Réglage de l'angle  
ES\_Ajuste del ángulo  
DE\_Winkelverstellung  
IT\_Regolazione dell'angolo

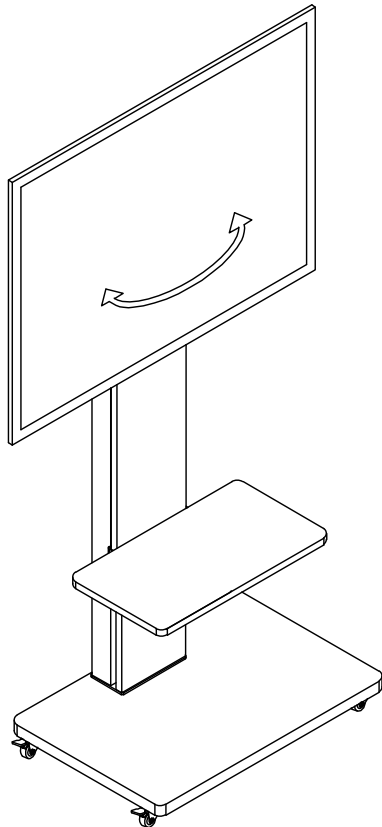

EN\_[Left and right angle adjustment]

Loosen the adjustment bolts shown in the figure to adjust the left and right angles. After adjusting the angle, tighten the bolts.

FR\_[Réglage de l'angle gauche et droit]

Desserrez les boulons de réglage indiqués sur la figure pour régler les angles gauche et droit. Après avoir réglé l'angle, resserrez les boulons.

ES\_[Ajuste del ángulo izquierdo y derecho]

Afloje los pernos de ajuste que se muestran en la figura para ajustar los ángulos izquierdo y derecho. Después de ajustar el ángulo, apriete los pernos.

DE\_[Einstellung des linken und rechten Winkels]

Lösen Sie die in der Abbildung gezeigten Einstellschrauben, um den linken und rechten Winkel einzustellen. Ziehen Sie die Schrauben nach der Winkeleinstellung wieder fest.

IT\_[Regolazione dell'angolo sinistro e destro]

Allentare i bulloni di regolazione mostrati nella figura per regolare gli angoli sinistro e destro. Dopo aver regolato l'angolo, serrare i bulloni.

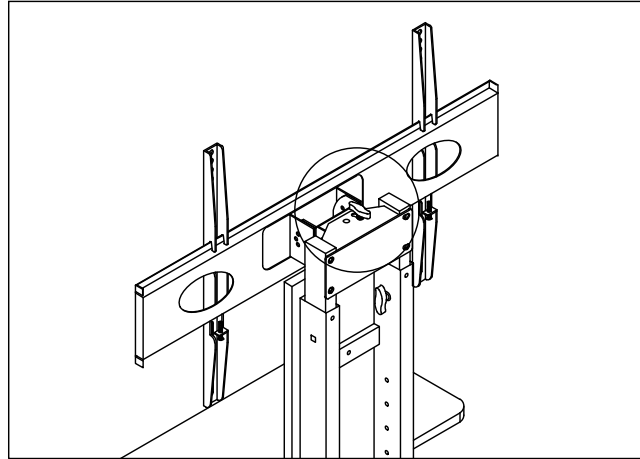

EN\_[Vertical angle adjustment]

Three levels of angle adjustment are possible. Loosen the adjustment bolts (left and right) shown in the figure, insert them into the three holes at any angle you like, and tighten them.

FR\_[Réglage de l'angle vertical]

Trois niveaux de réglage de l'angle sont possibles. Desserrez les boulons de réglage (gauche et droit) indiqués sur la figure, insérez-les dans les trois trous à l'angle souhaité, puis resserrez-les.

ES\_[Ajuste del ángulo vertical]

Se pueden realizar tres niveles de ajuste del ángulo. Afloje los pernos de ajuste (izquierdo y derecho) que se muestran en la figura, insértelos en los tres orificios en el ángulo que desee y apriéte los.

DE\_[Vertikale Winkeleinstellung]

Es sind drei Stufen der Winkeleinstellung möglich. Lösen Sie die in der Abbildung gezeigten Einstellschrauben (links und rechts), stecken Sie sie in einem beliebigen Winkel in die drei Löcher und ziehen Sie sie fest.

IT\_[Regolazione dell'angolo verticale]

Sono disponibili tre livelli di regolazione dell'angolo. Allentare i bulloni di regolazione (sinistro e destro) mostrati nella figura, inserirli nei tre fori con l'angolazione desiderata e serrarli.

