

# MONTAGEANLEITUNG

Artikelnummer: WF197915

## Kinderbett mit Schornstein 200x90cm

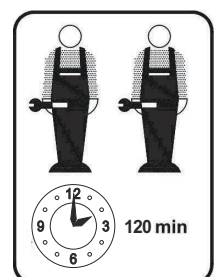
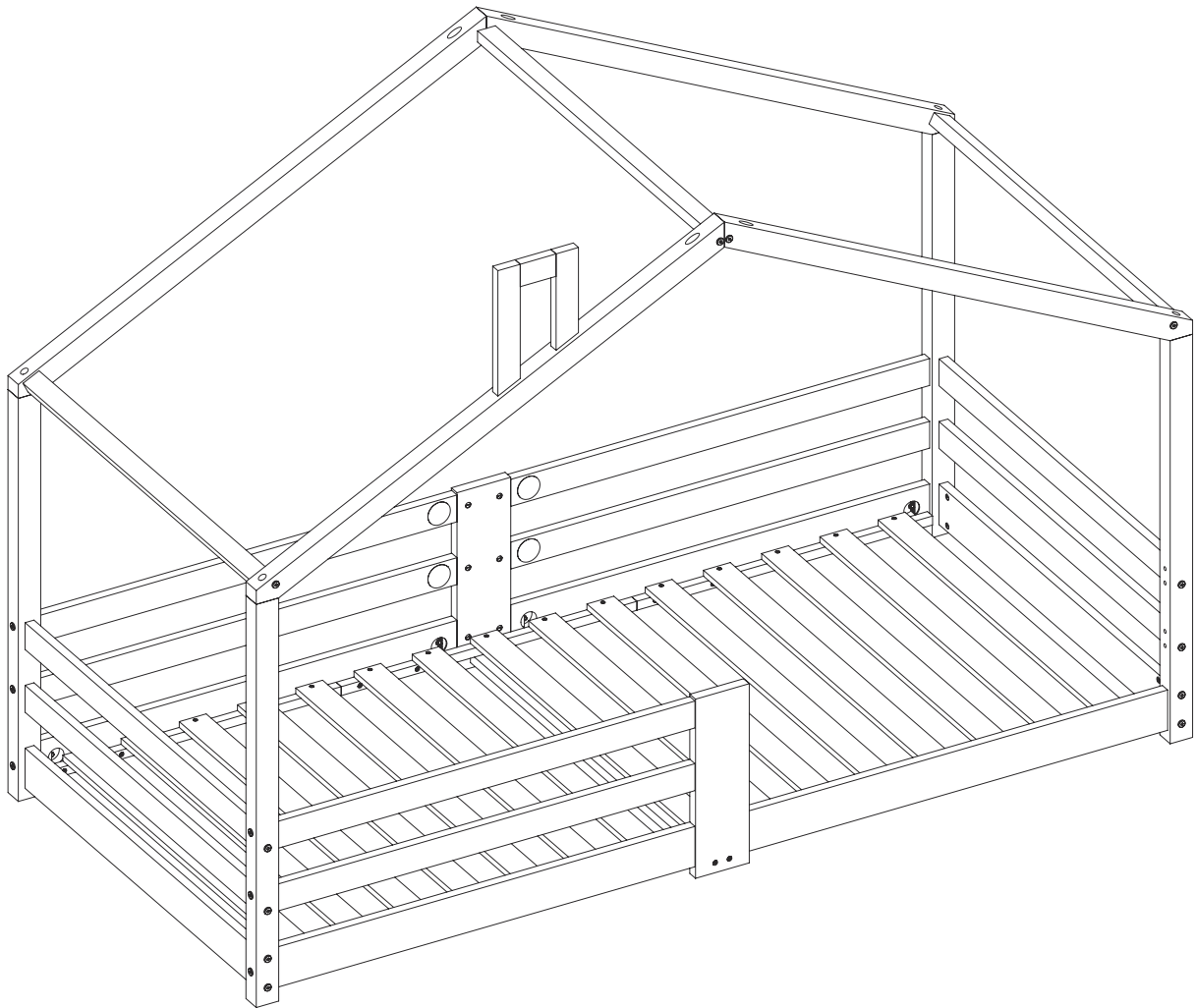

## English

### IMPORTANT ! KEEP FOR FUTURE REFERENCE : READ CAREFULLY

- To be assembled by an adult. Assembly must be checked by an adult before use
- WARNING ! Keep all screws, small parts and plastic bags out of the reach of children
- Properly identify all parts before assembling
- Never use your item if any of its parts are broken or missing
- Should any problems arise, please contact our After Sales Service
- Manufacturer's instructions shall be followed at all times
- Care: Clean with a soft, dry cloth. In case of larger stains, carefully rub with a slightly damp, non-abrasive sponge
- Avoid the risk of fire by not placing furniture near sources of ignition or hot items
- Do not jump on the bed

## Deutsch

### WICHTIG ! ZUM SPÄTEREN NACHSCHLAGEN AUFBEWAHREN: SORGFÄLTIG LESEN

- Muss von einem Erwachsenen zusammengebaut werden. Der Zusammenbau muss vor dem Gebrauch von einem Erwachsenen überprüft werden
- WARNUNG! Bewahren Sie alle Schrauben, Kleinteile und Plastikbeutel außerhalb der Reichweite von Kindern auf
- Kennzeichnen Sie vor dem Zusammenbau alle Teile richtig
- Benutzen Sie Ihren Artikel niemals, wenn Teile gebrochen sind oder fehlen
- Sollten Probleme auftreten, wenden Sie sich bitte an unseren Kundendienst
- Die Anweisungen des Herstellers sind stets zu befolgen
- Pflege: Mit einem weichen, trockenen Tuch reinigen. Bei größeren Flecken vorsichtig mit einem leicht feuchten, nicht scheuernden Schwamm abreiben. nicht scheuernden Schwamm
- Vermeiden Sie die Gefahr eines Brandes, indem Sie die Möbel nicht in der Nähe von Zündquellen oder heißen Gegenständen aufstellen
- Nicht auf das Bett springen

## Français

### IMPORTANT ! CONSERVER POUR RÉFÉRENCE ULTÉRIEURE : LIRE ATTENTIVEMENT

- Le montage doit être effectué par un adulte. Le montage doit être vérifié par un adulte avant Utilisation
- ATTENTION ! Tenir les vis, les petites pièces et les sachets en plastique hors de portée des enfants
- Identifiez correctement toutes les pièces avant de les assembler
- N'utilisez jamais votre article si l'une de ses pièces est cassée ou manquante
- En cas de problème, veuillez contacter notre service après-vente
- Les instructions du fabricant doivent être respectées à tout moment
- Entretien : nettoyer avec un chiffon doux et sec. En cas de taches plus importantes, frotter soigneusement avec une éponge non abrasive légèrement humide. légèrement humide et non Abrasive
- Évitez les risques d'incendie en ne plaçant pas les meubles à proximité de sources d'inflammation ou d'objets chauds
- Ne pas sauter sur le lit

## Italiano

### IMPORTANTE! CONSERVARE PER RIFERIMENTO FUTURO: LEGGERE ATTENTAMENTE

- Deve essere assemblato da un adulto. L'assemblaggio deve essere controllato da un adulto prima dell'uso
- **ATTENZIONE!** Tenere tutte le viti, le piccole parti e i sacchetti di plastica fuori dalla portata dei bambini
- Identificare correttamente tutte le parti prima dell'assemblaggio
- Non utilizzare mai l'articolo se alcune parti sono rotte o mancanti
- In caso di problemi, si prega di contattare il nostro Servizio Post Vendita
- Le istruzioni del produttore devono essere sempre seguite
- Cura: Pulire con un panno morbido e asciutto. In caso di macchie più estese, strofinare accuratamente con una spugna leggermente umida e nonspugna leggermente umida e non abrasiva
- Evitare il rischio di incendio, non collocando i mobili vicino a fonti di accensione o a oggetti caldi
- Non saltare sul letto

## Español

### ¡ IMPORTANTE ! CONSERVELO PARA FUTURAS CONSULTAS: LEA ATENTAMENTE



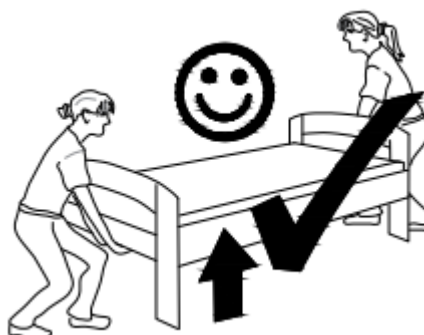
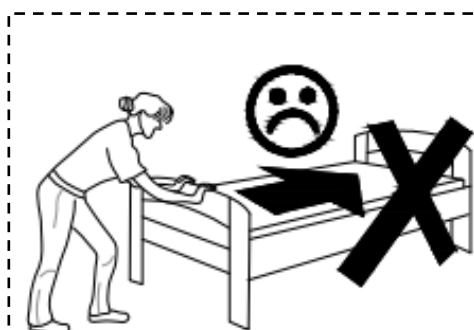



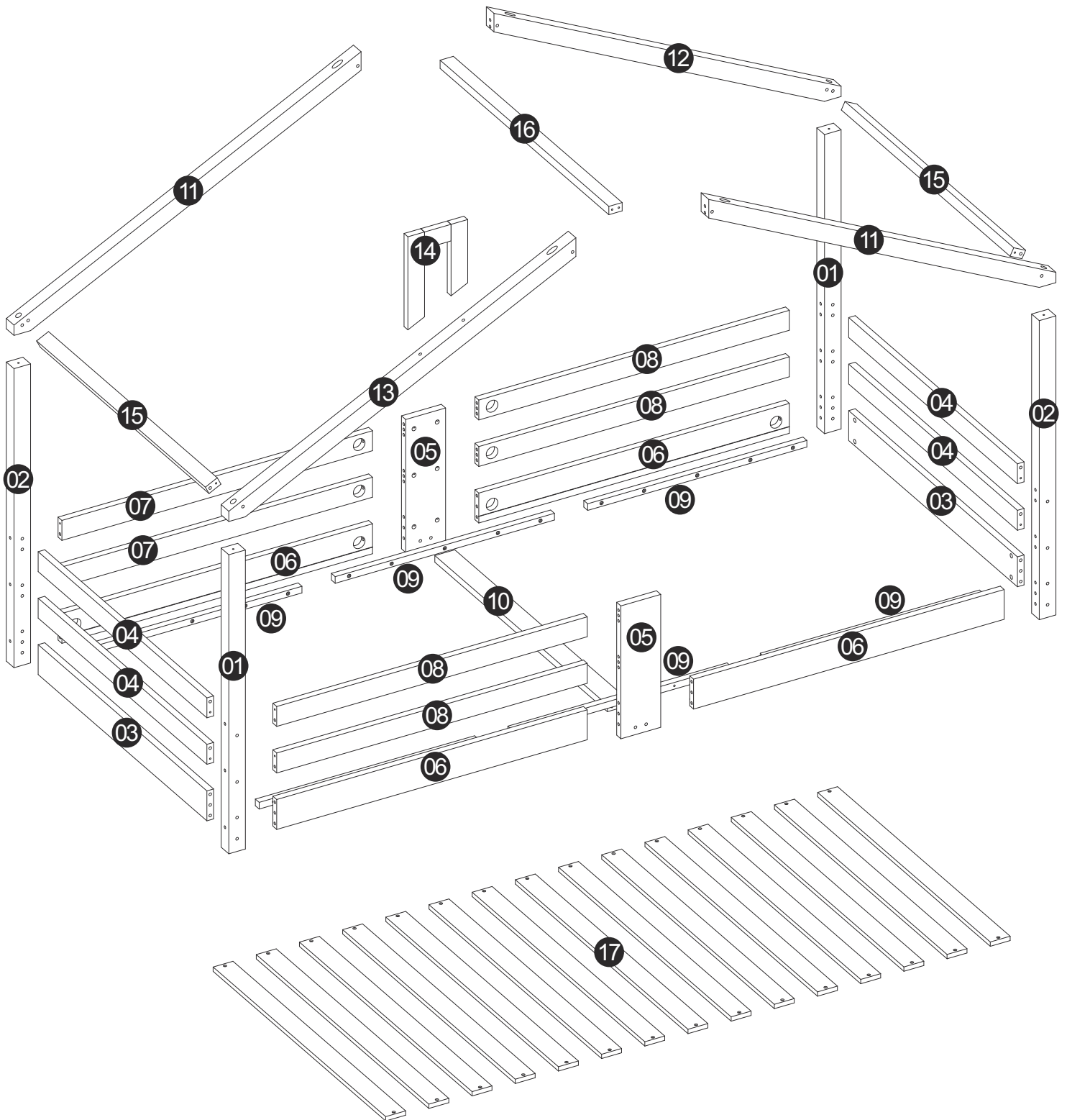



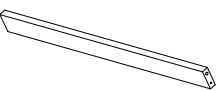
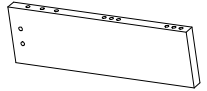

- Debe ser montado por un adulto. El montaje debe ser comprobado por un adulto antes del uso
- ADVERTENCIA Mantenga todos los tornillos, piezas pequeñas y bolsas de plástico fuera del alcance de los niños.
- Identifique correctamente todas las piezas antes de montarlas
  - Nunca utilice su artículo si alguna de sus piezas está rota o falta
  - Si surge algún problema, póngase en contacto con nuestro Servicio Postventa
  - Las instrucciones del fabricante deben seguirse en todo momento
  - Cuidado: Limpiar con un paño suave y seco. En caso de manchas más grandes, frote cuidadosamente con una esponja no abrasiva ligeramente humedecida.
  - Evite el riesgo de incendio no colocando los muebles cerca de fuentes de ignición u objetos calientes.
  - No saltar sobre la cama.



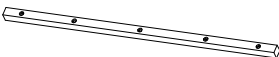



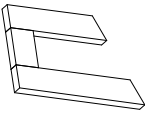

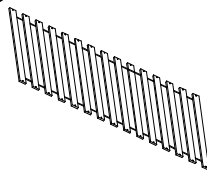

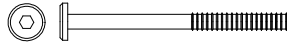
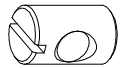

# Stückliste

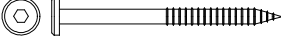
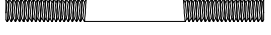
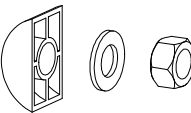

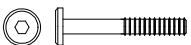
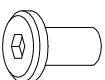
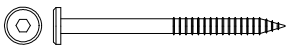



# WF197915

<p><b>01x2</b></p> 	<p><b>02x2</b></p> 	<p><b>03x2</b></p> 	<p><b>04x4</b></p> 
<p><b>05x2</b></p> 	<p><b>06x4</b></p> 	<p><b>07x2</b></p> 	<p><b>08x4</b></p> 
<p><b>09x6</b></p> 	<p><b>10x1</b></p> 	<p><b>11x2</b></p> 	<p><b>12x1</b></p> 
<p><b>13x1</b></p> 	<p><b>14x1</b></p> 	<p><b>15x2</b></p> 	<p><b>16x1</b></p> 
<p><b>17x1</b></p> 			

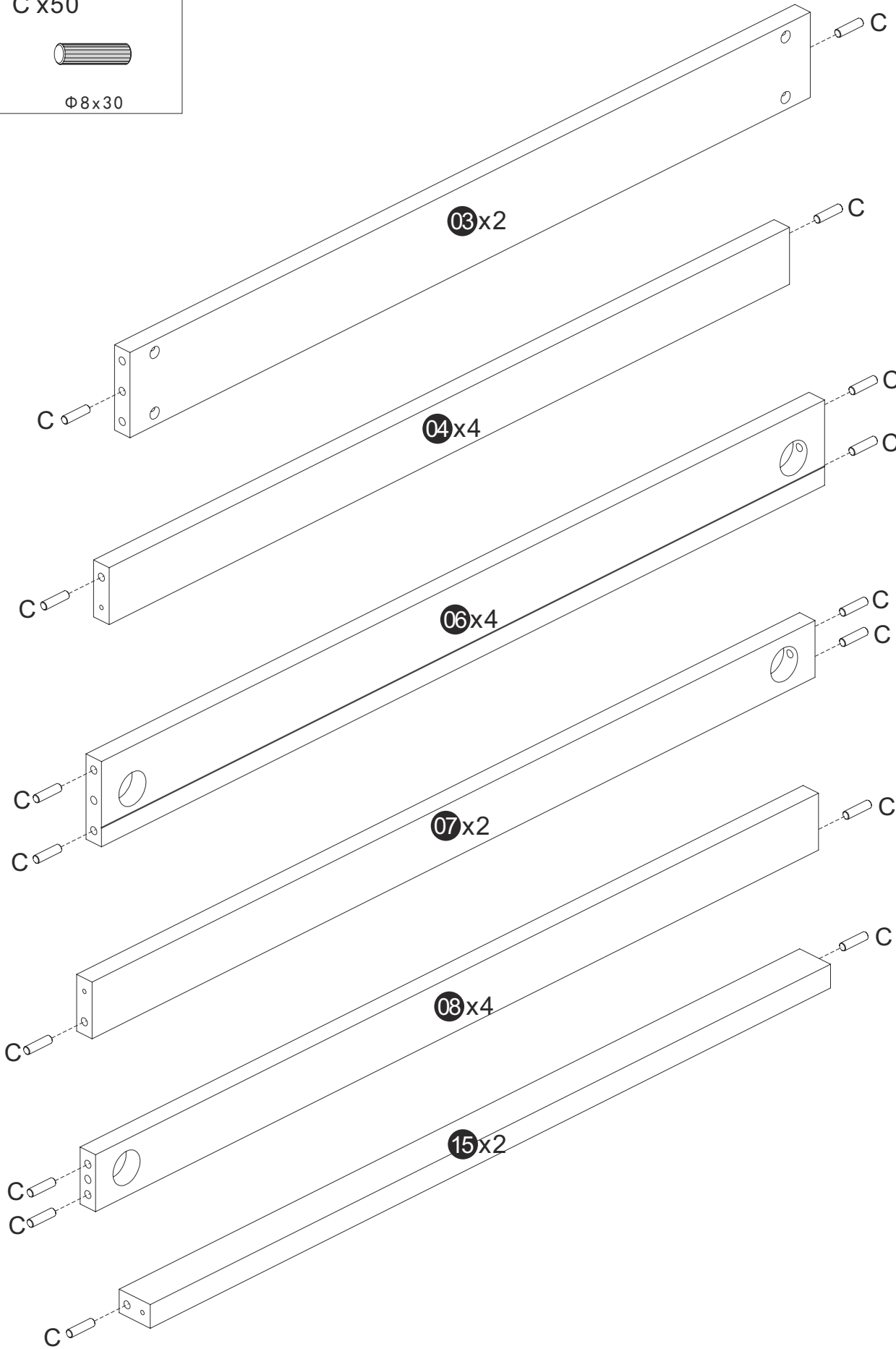
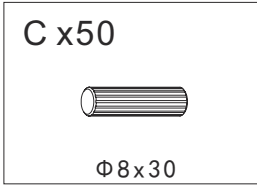
## Hardware-Liste

<p><b>A x12</b></p>  <p>M6 x90</p>	<p><b>B x18</b></p> 	<p><b>C x52</b></p>  <p>Φ8 X30</p>	<p><b>D x24</b></p>  <p>Φ6 X90</p>
<p><b>E x10</b></p>  <p>M6 x70</p>	<p><b>F x14</b></p> 	<p><b>G x60</b></p>  <p>Φ4 X30</p>	<p><b>H x4</b></p>  <p>Φ7 X50</p>
<p><b>J x2</b></p>  <p>M6 x50</p>	<p><b>K x2</b></p> 	<p><b>L x4</b></p>  <p>Φ6 X80</p>	<p><b>M x12</b></p> 
<p><b>N x6</b></p> 	<p><b>P x2</b></p> 	<p><b>Q x2</b></p> 	<p><b>O x2</b></p> 



A x8  M6x90	B x8 	D x8  Φ6x90
----------------------------------------------------------------------------------------------------	-------------------------------------------------------------------------------------------	----------------------------------------------------------------------------------------------------

2x

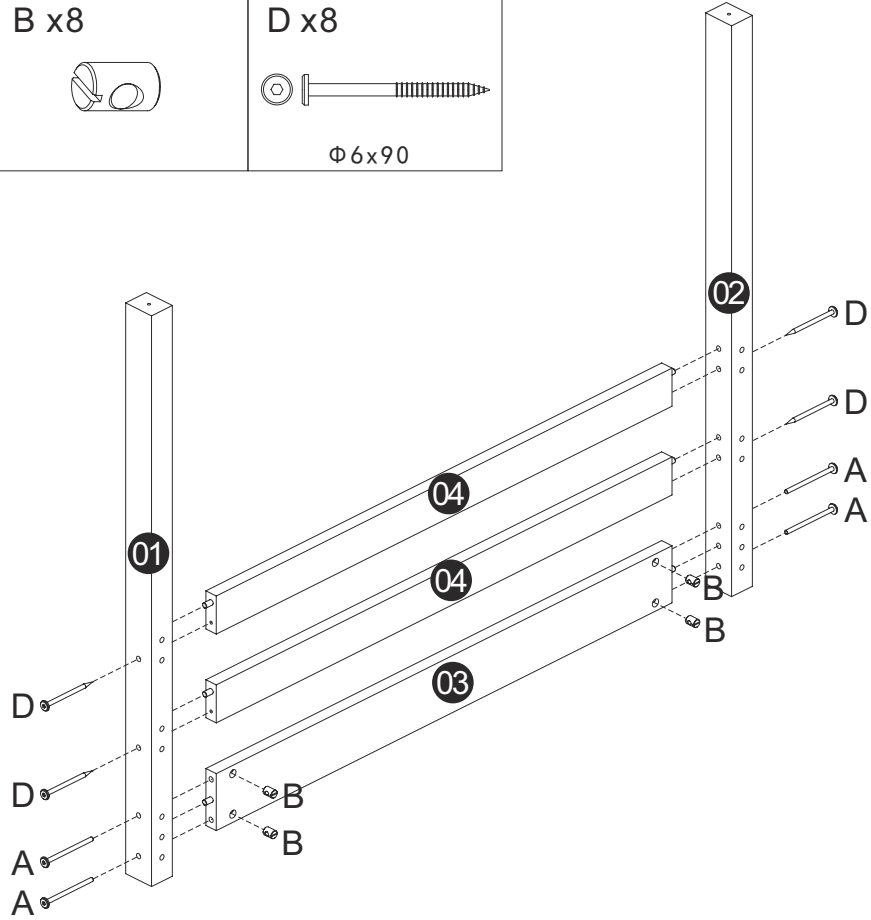

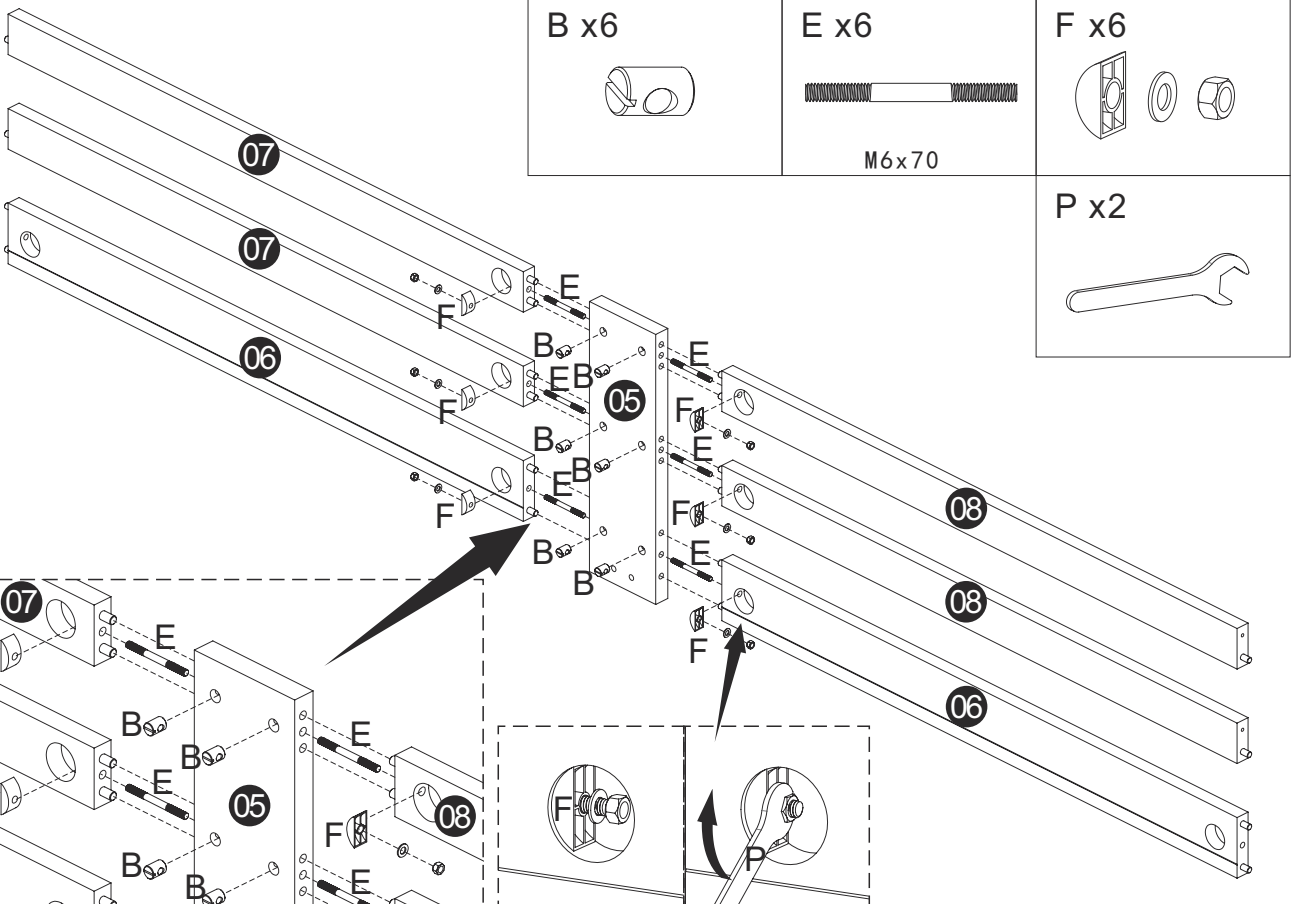

# 3

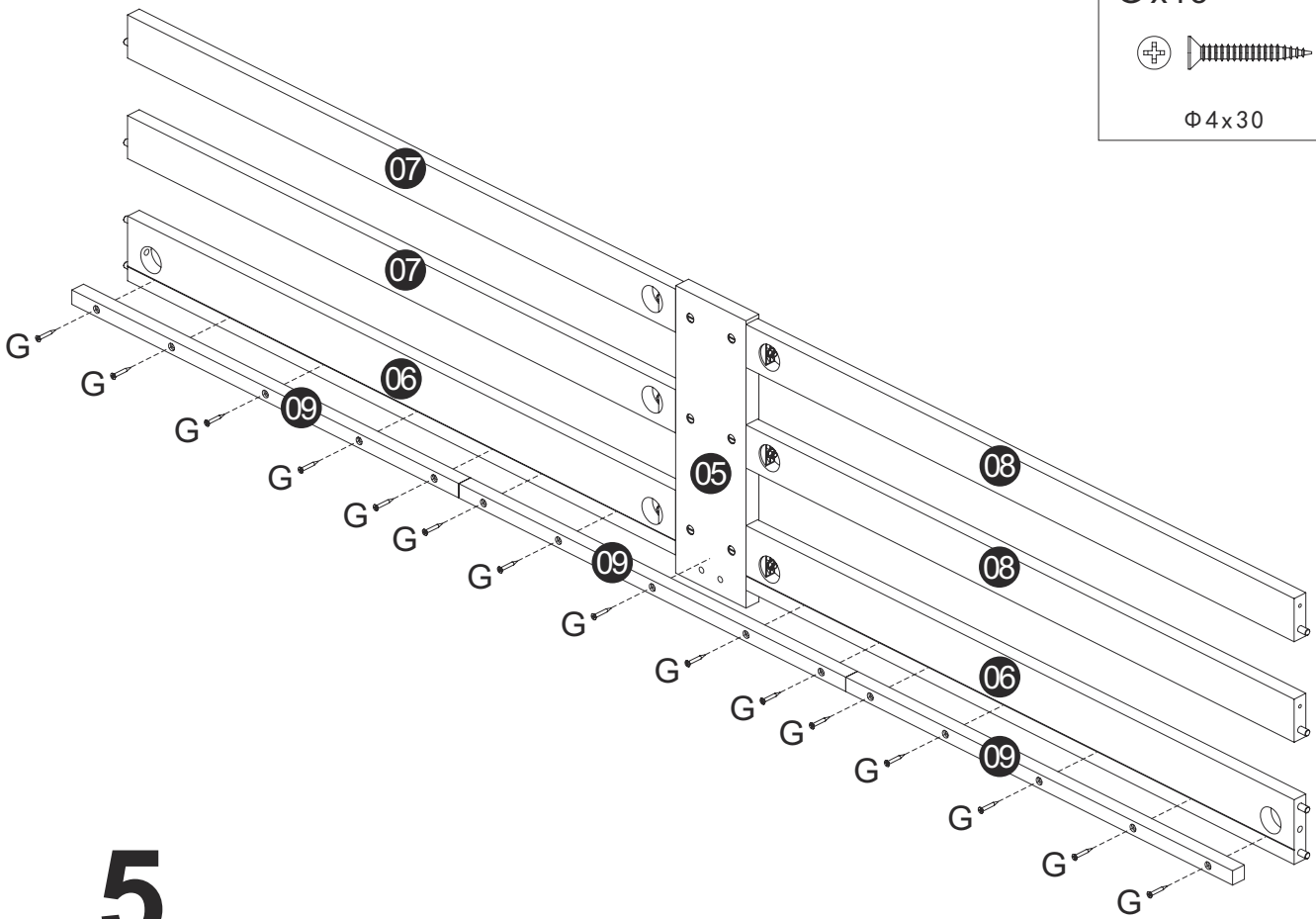

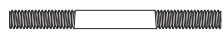
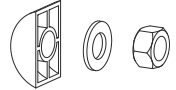

# 5

<p>B x4</p> 	<p>E x4</p>  <p>M6x70</p>	<p>F x4</p> 
<p>P x2</p> 		

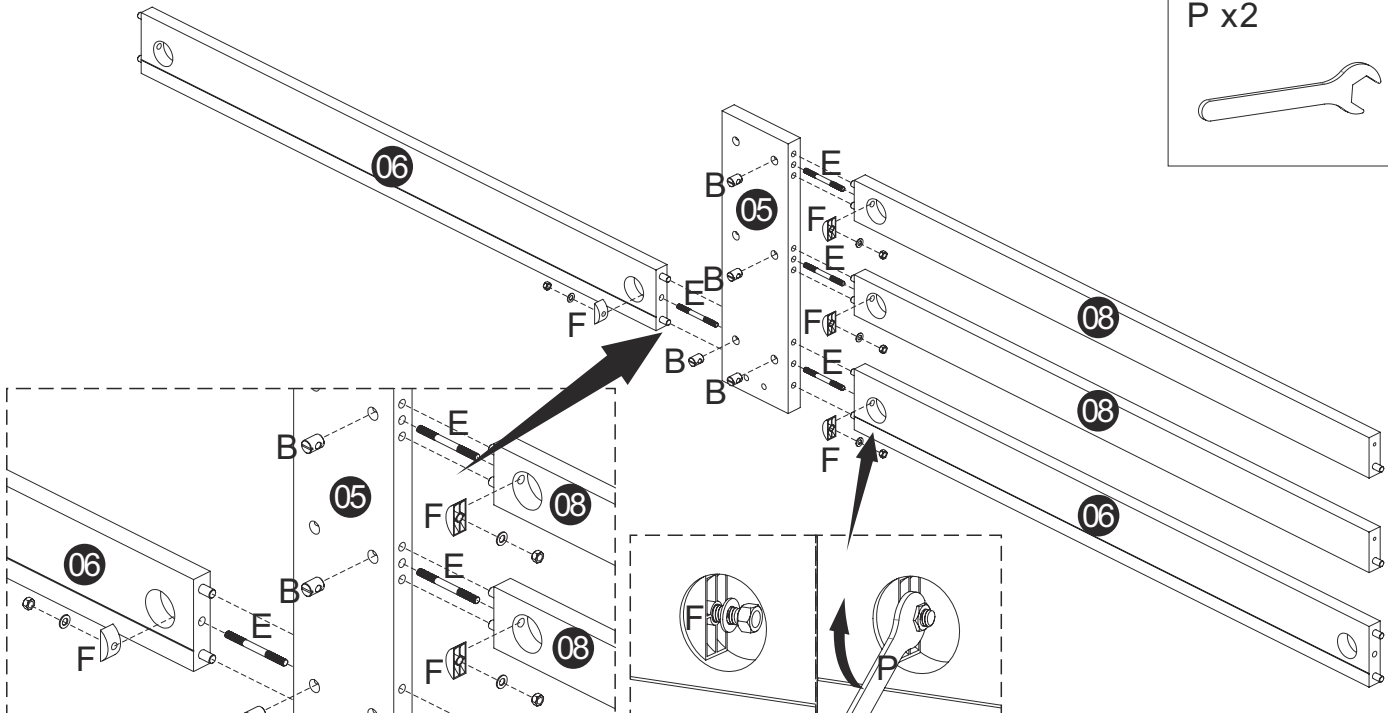

# 6

G x15



Φ4x30

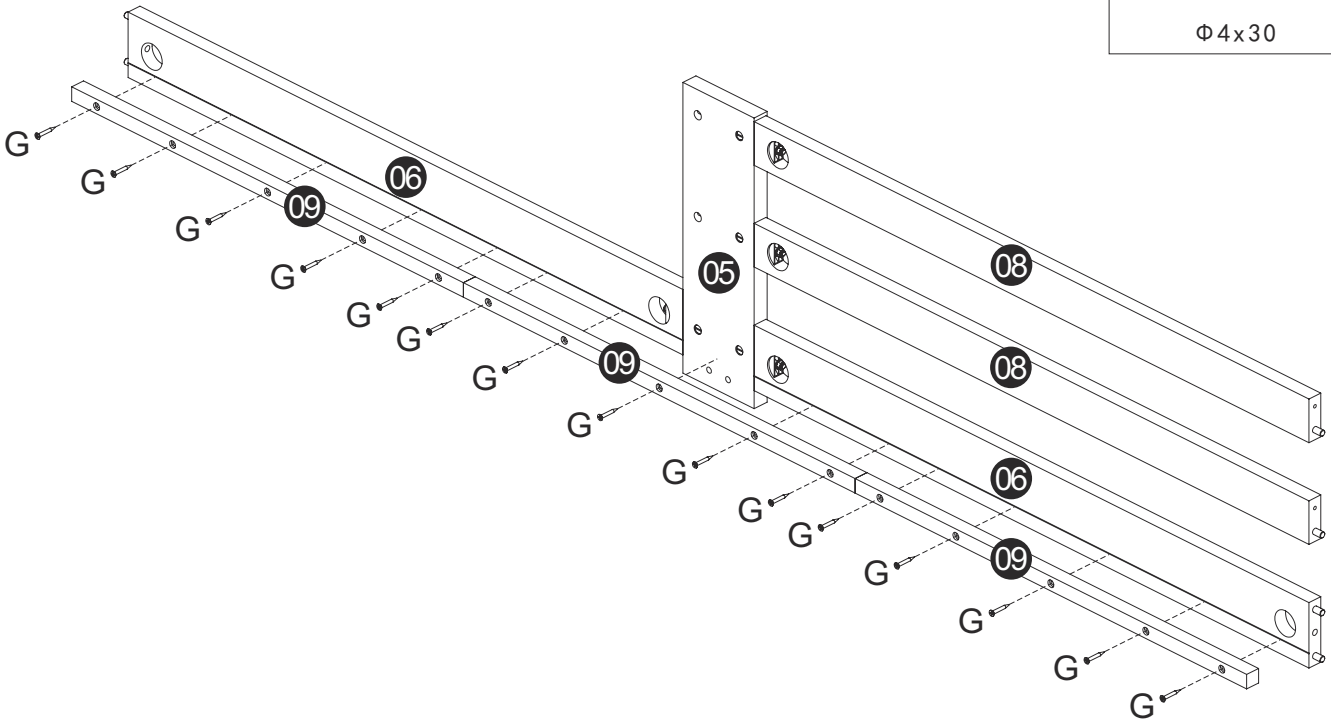

# 7

H x4



Φ7x50

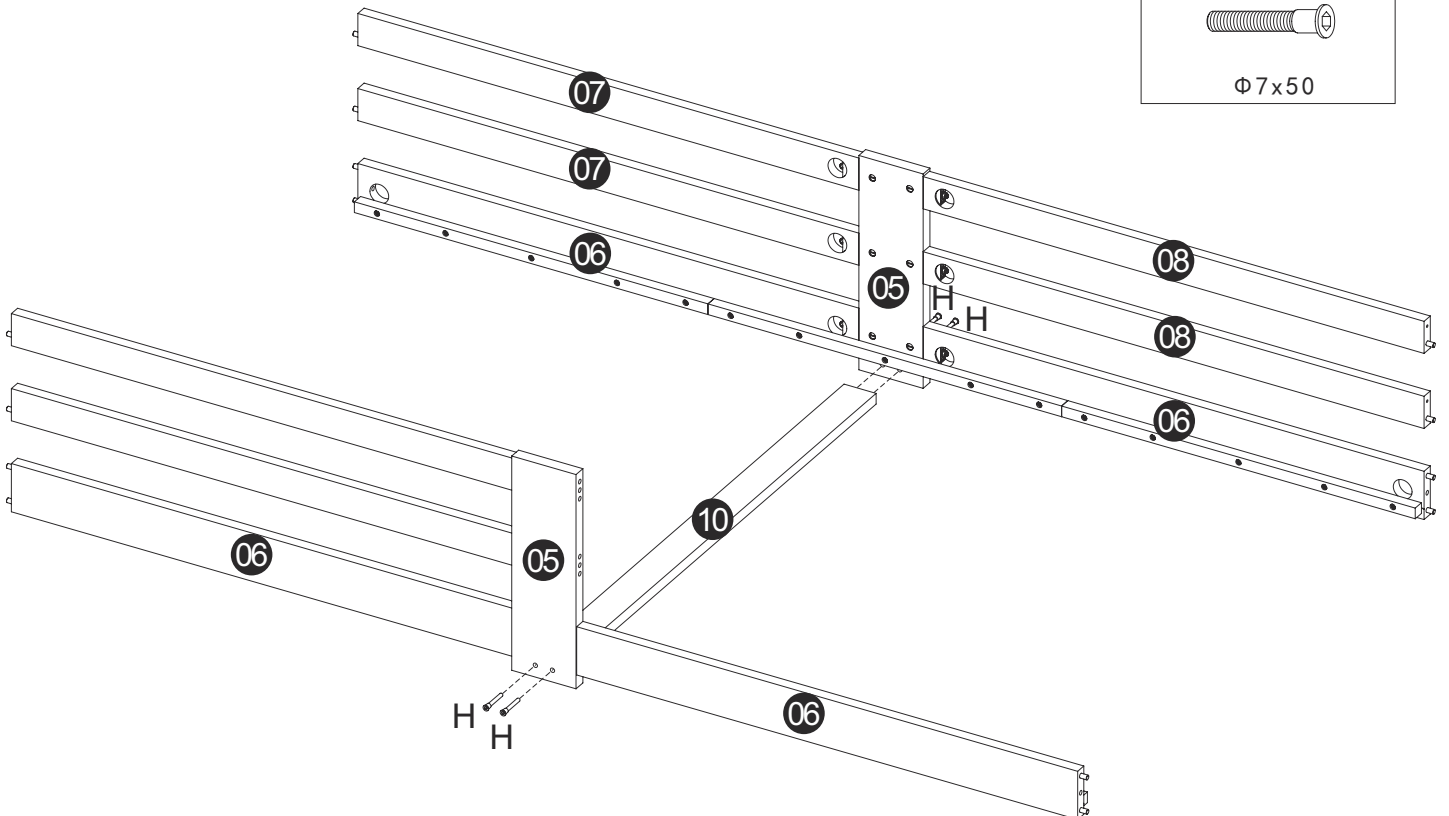

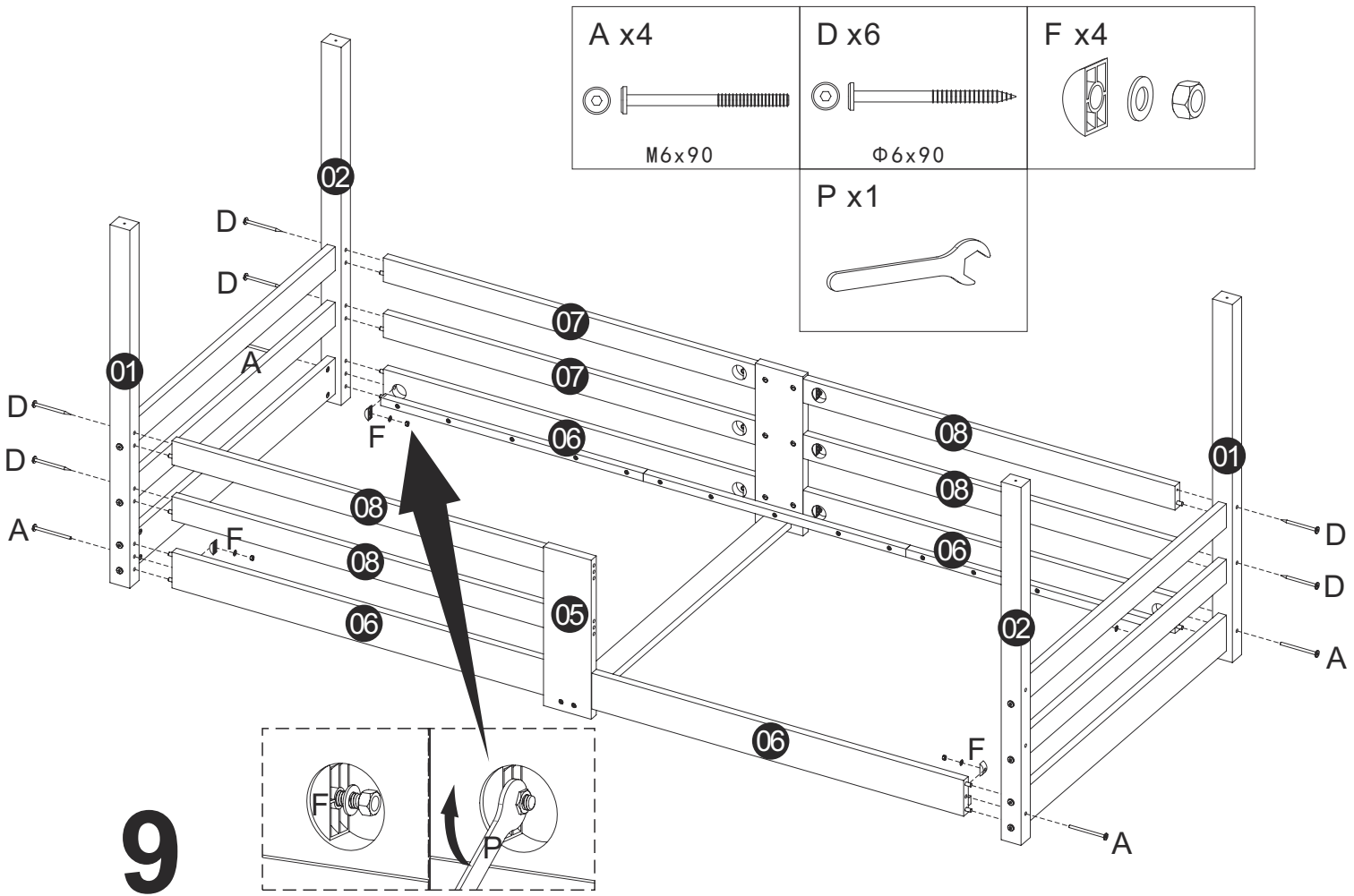

# 9

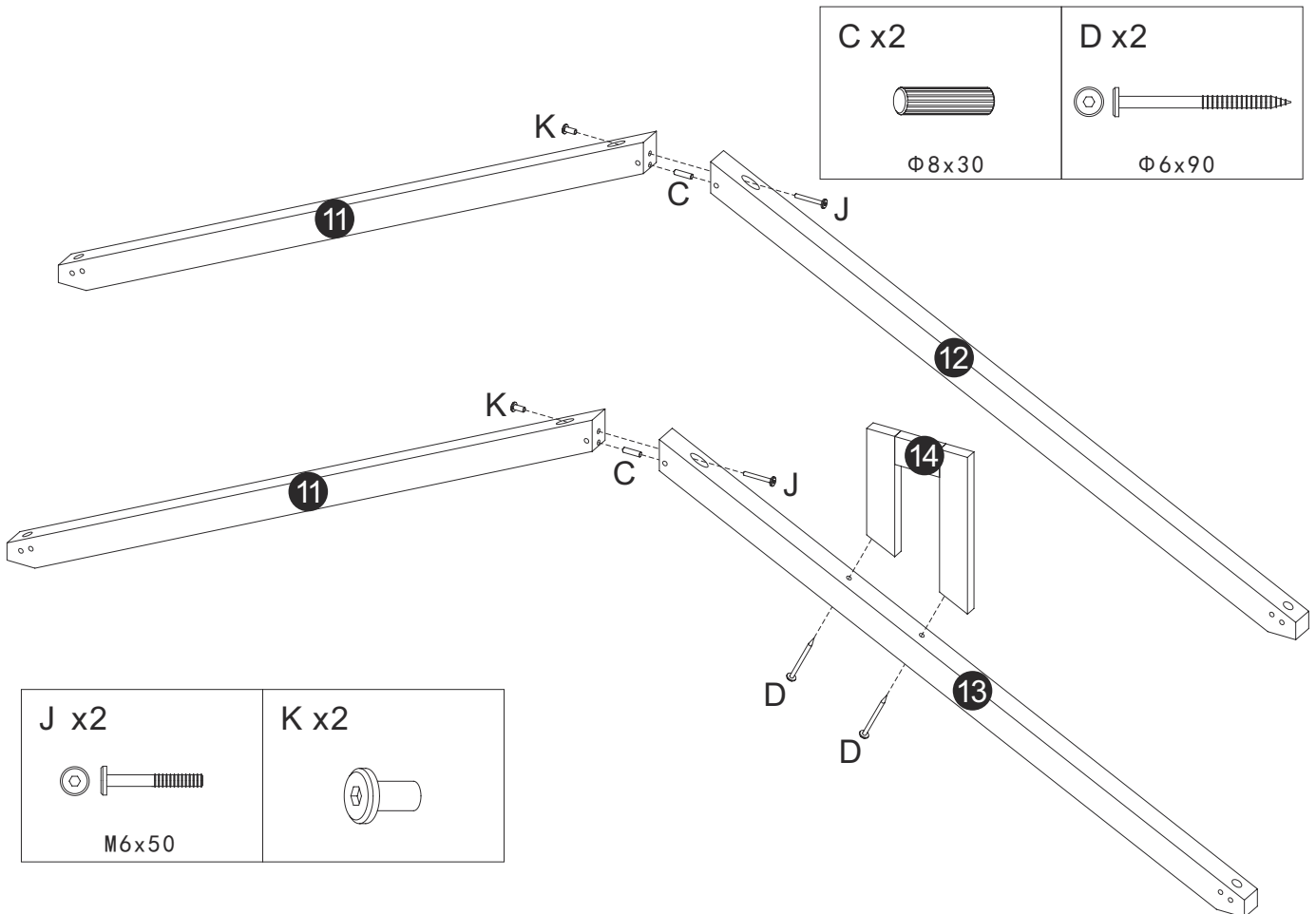

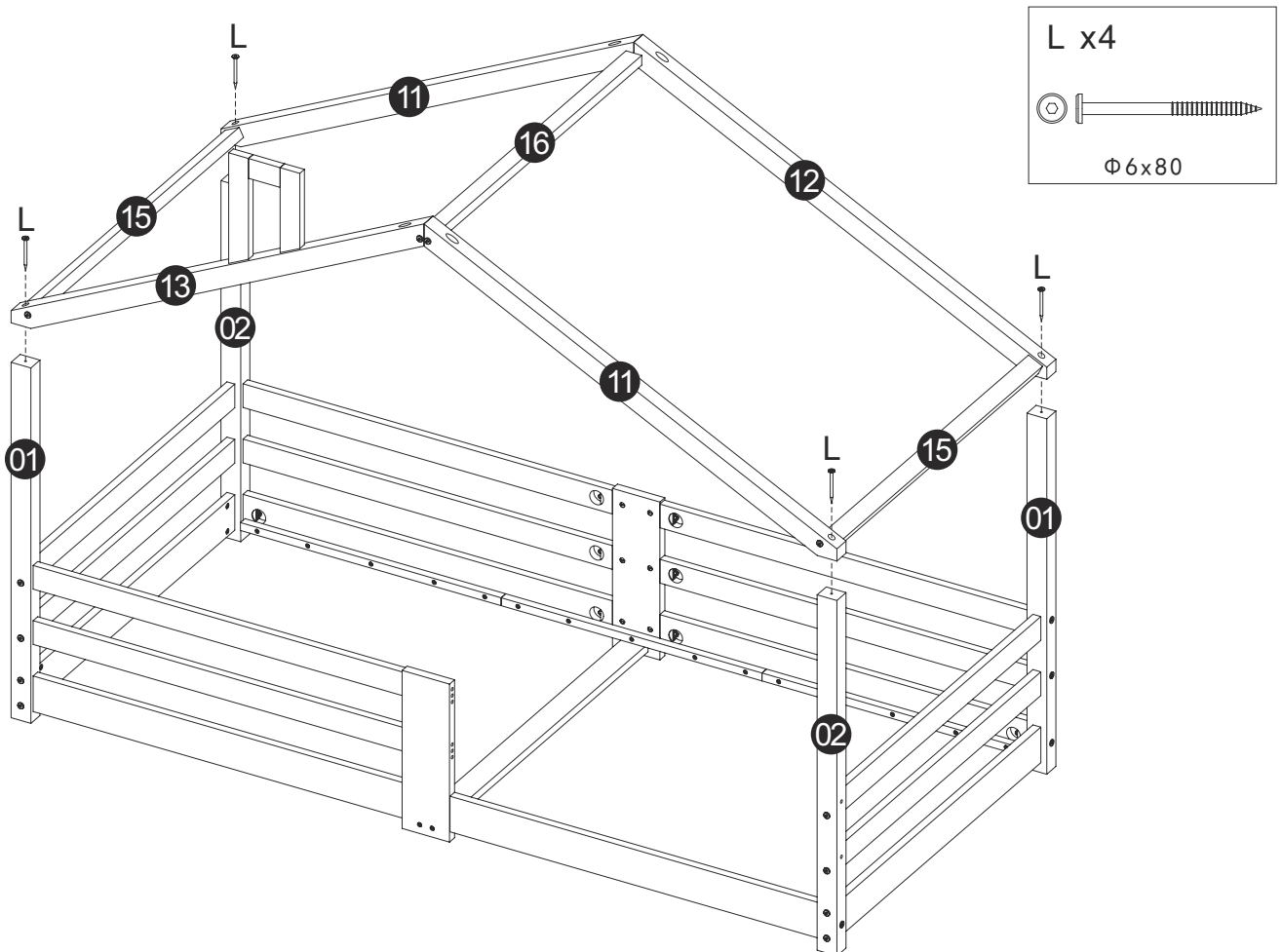
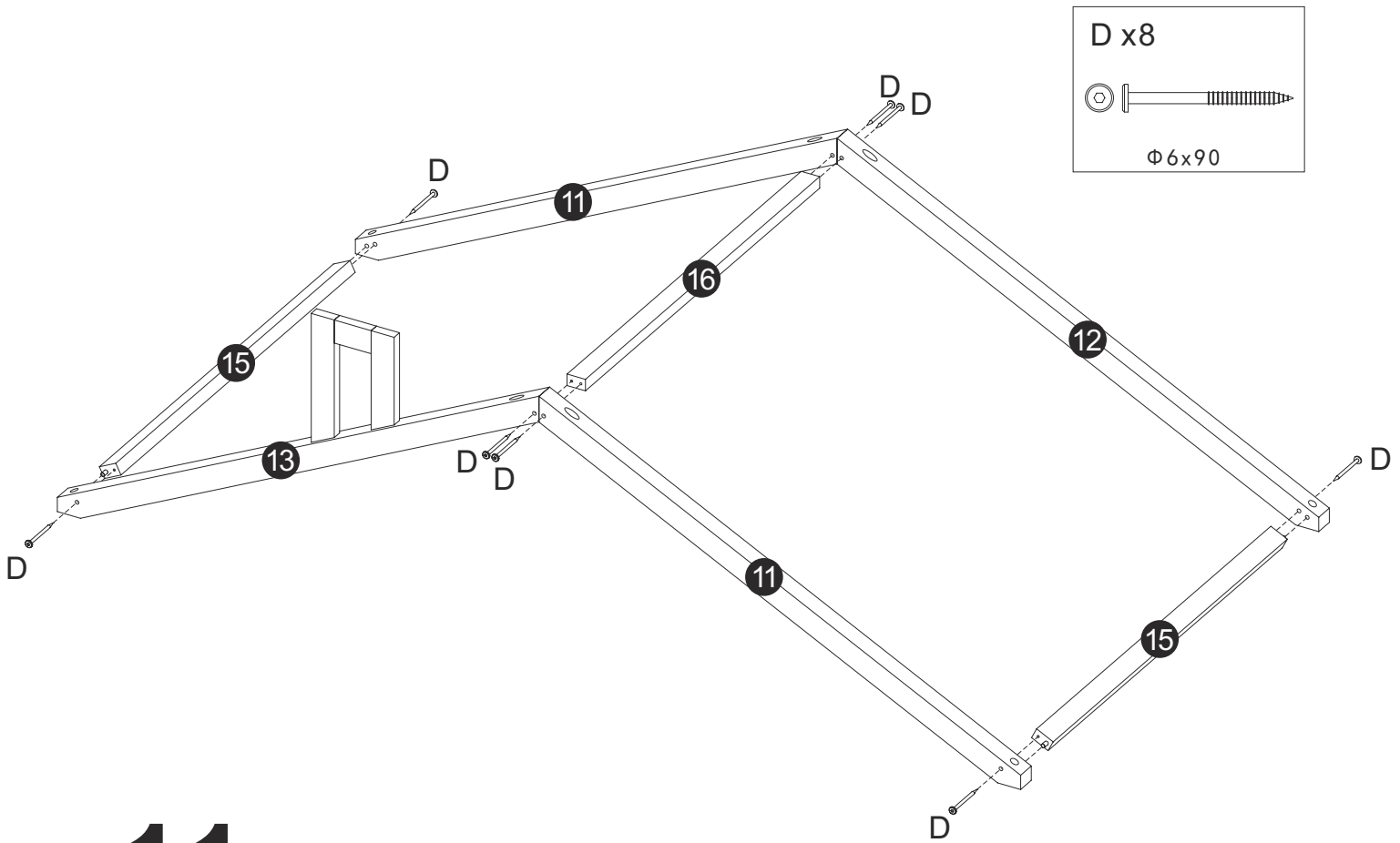

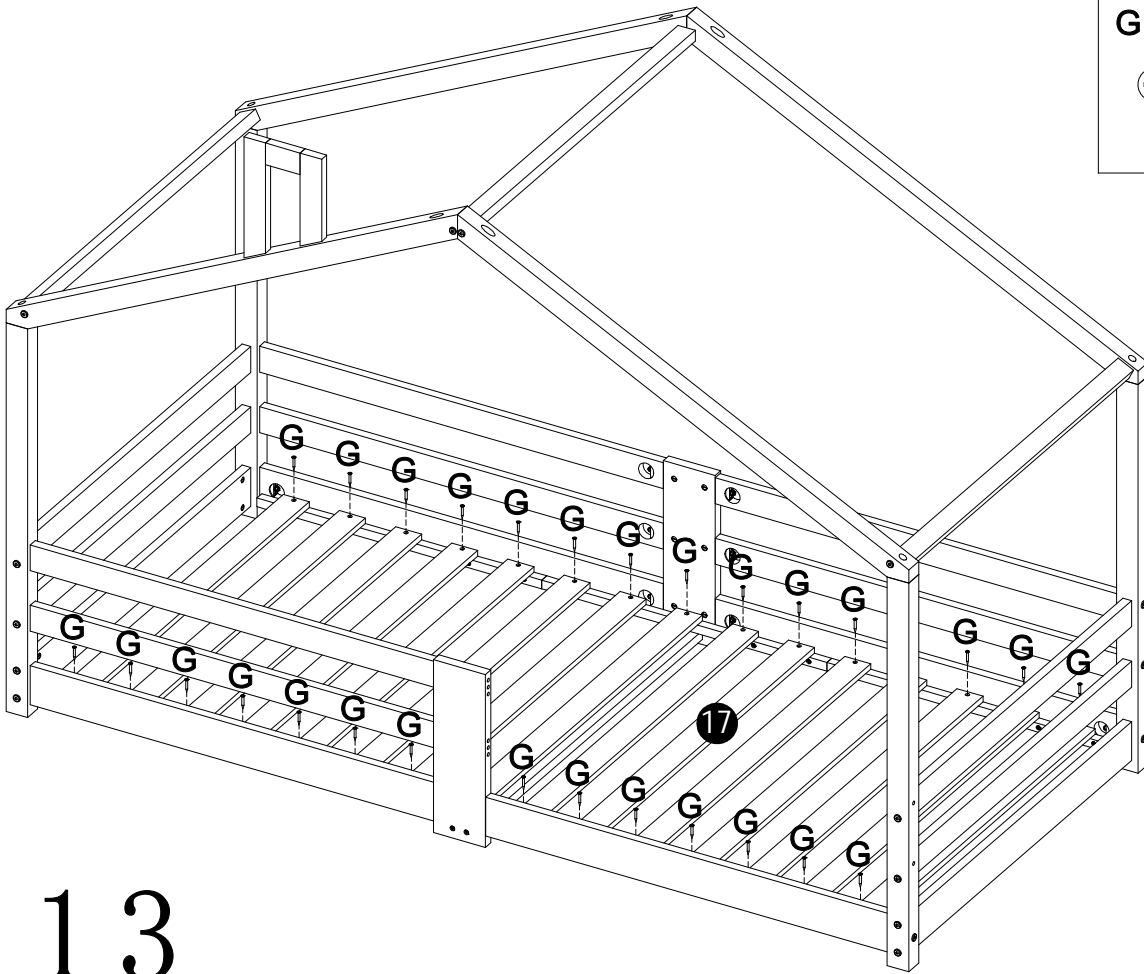

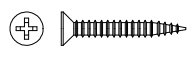

G x30

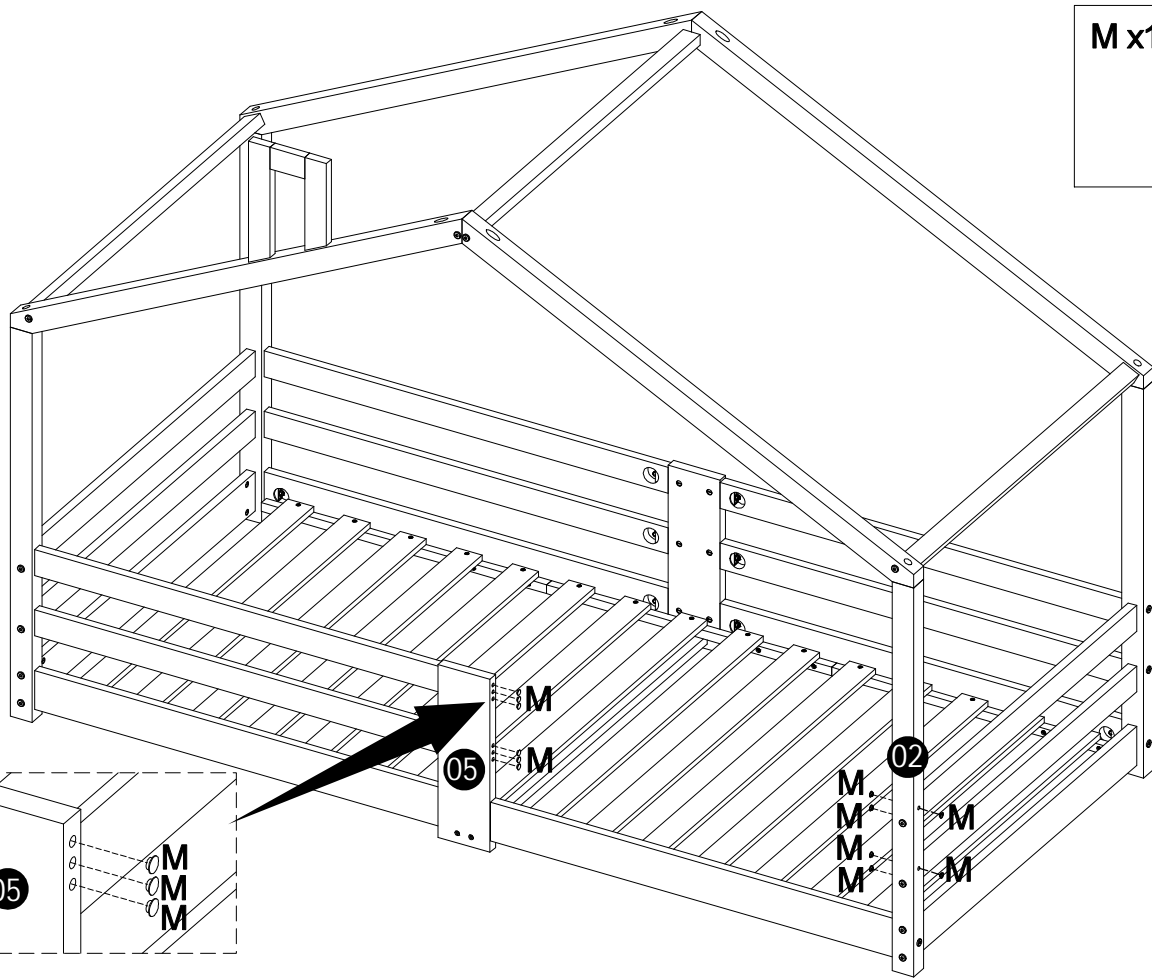

Φ4 X30



M x12



O x2



N x6

