

MARLY

R-1

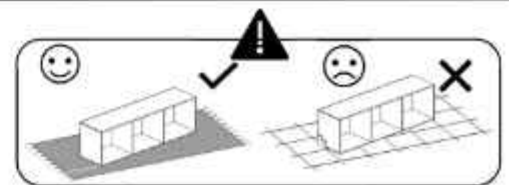

No	T(mm)	L(mm)	W(mm)	pcs.
1	18	896	600	1
1	18	896	600	1
3	16	1692	533	2
4	66	1692	66	2
5	16	1692	555	1
6	16	1692	555	1
7	16	762	555	1
8	16	762	150	1
9	18	1088	376	2
10	18	194	756	1
11	18	194	756	2
12	16	350	140	3
13	16	350	140	3
14	16	704	140	3
15	3	717	346	3
16	3	614	794	1
17	3	543,5	794	2

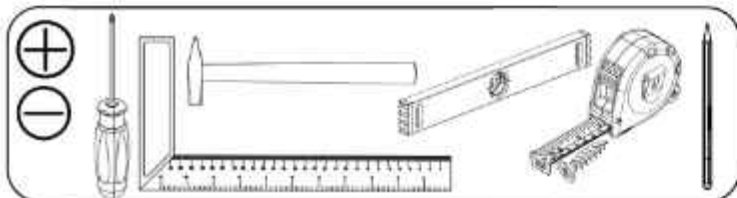
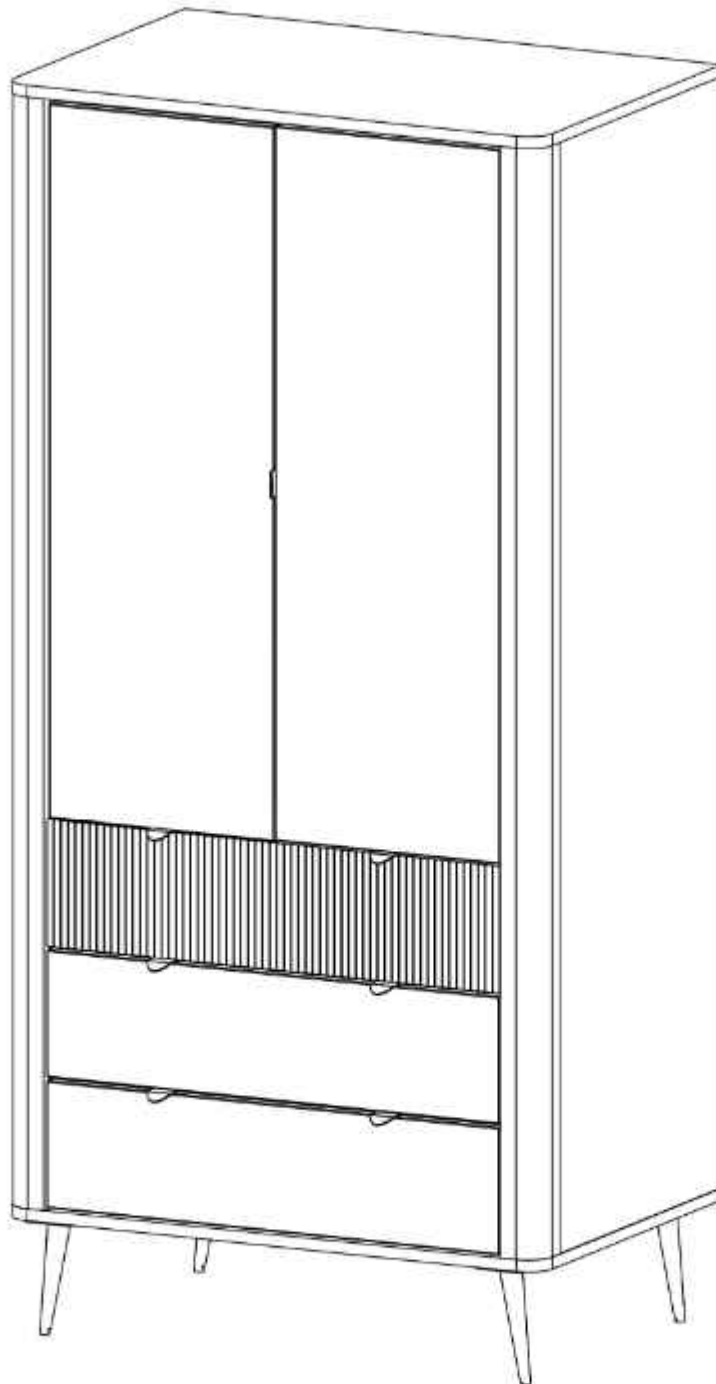
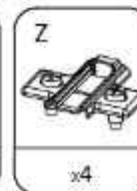
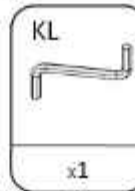
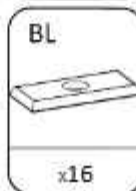
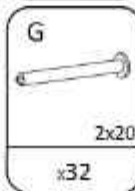
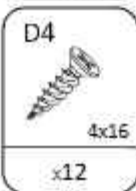
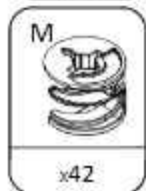
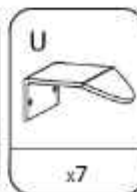
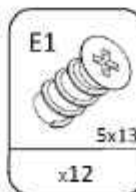
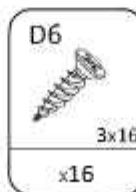
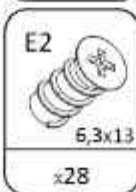
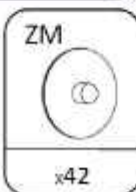
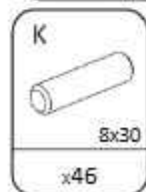
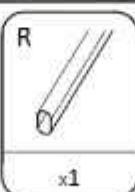
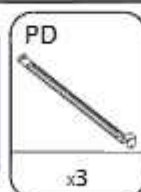
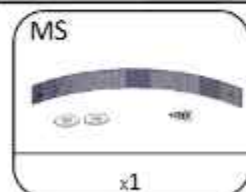
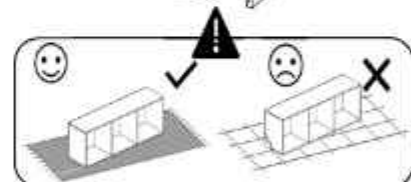
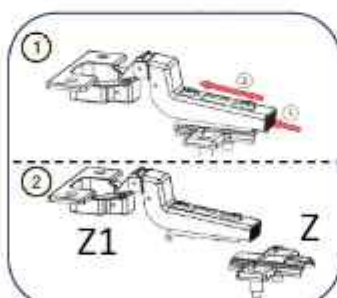
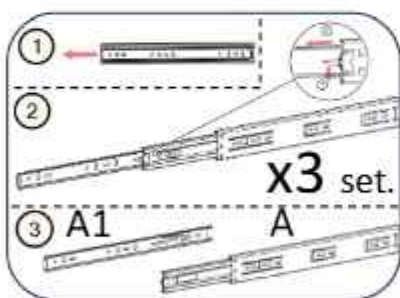
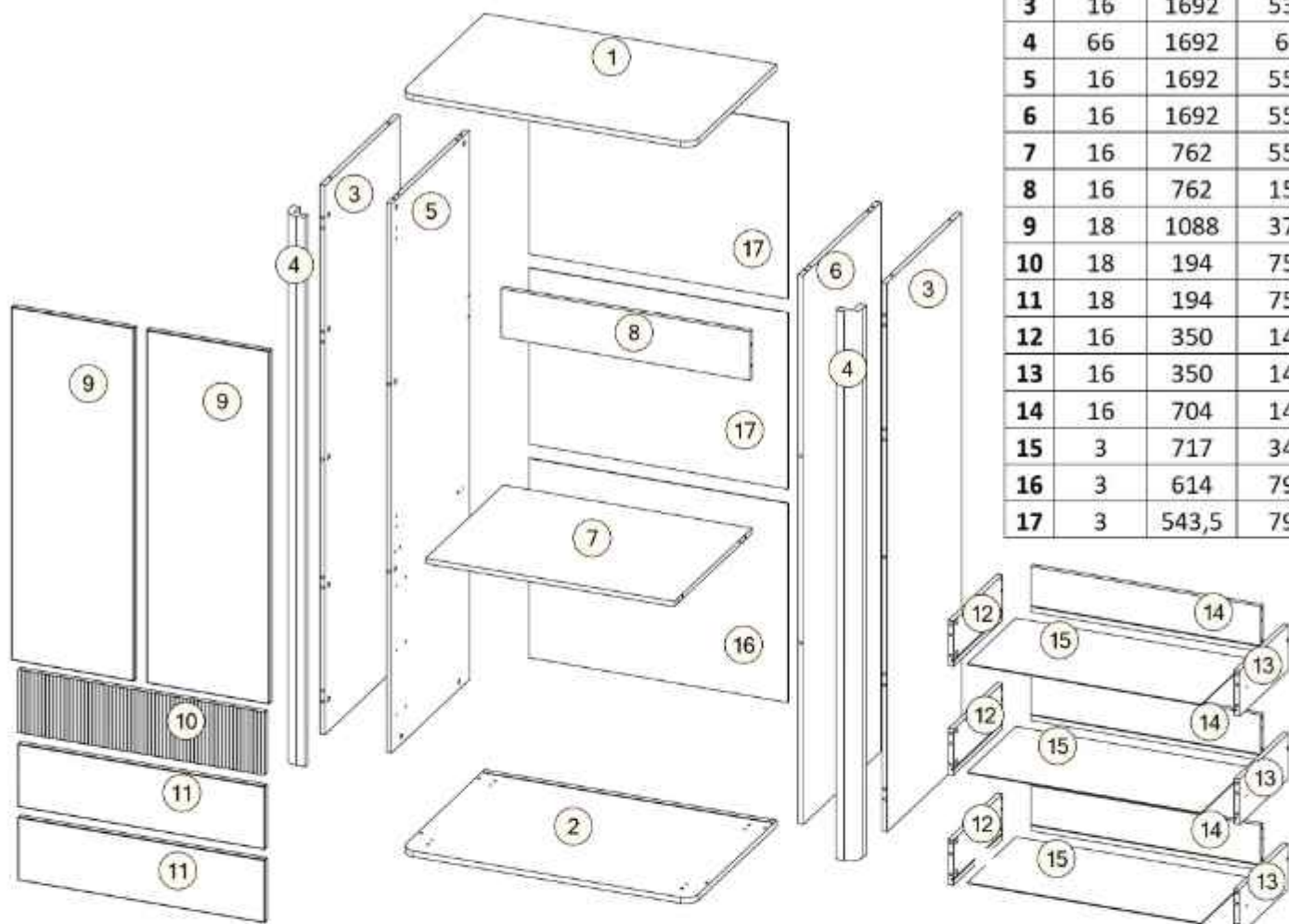

1

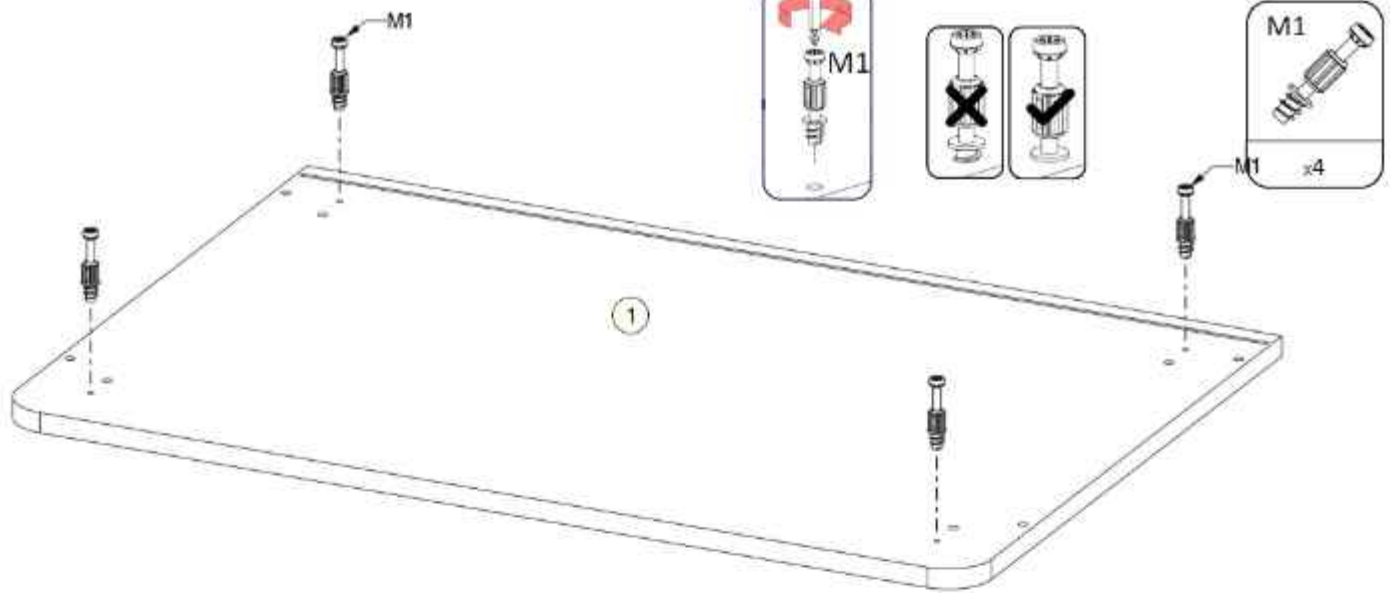

2

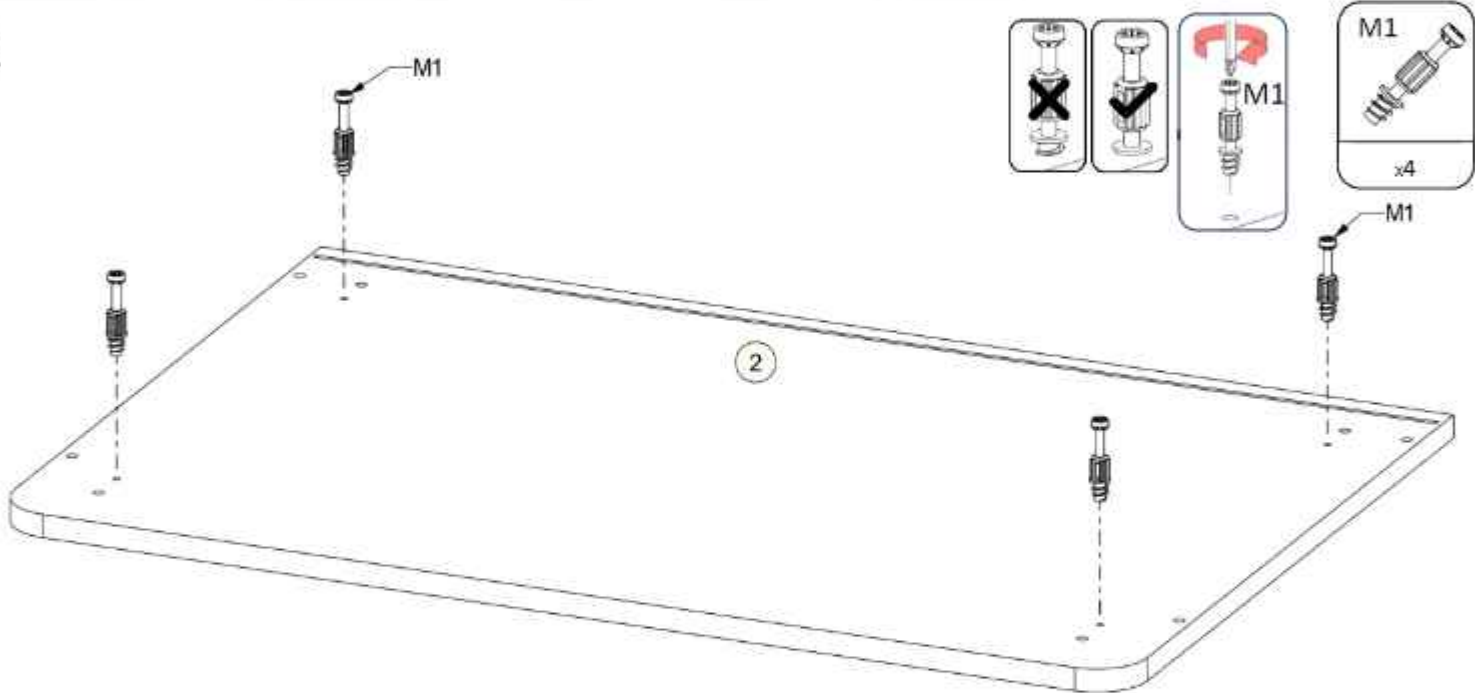

3

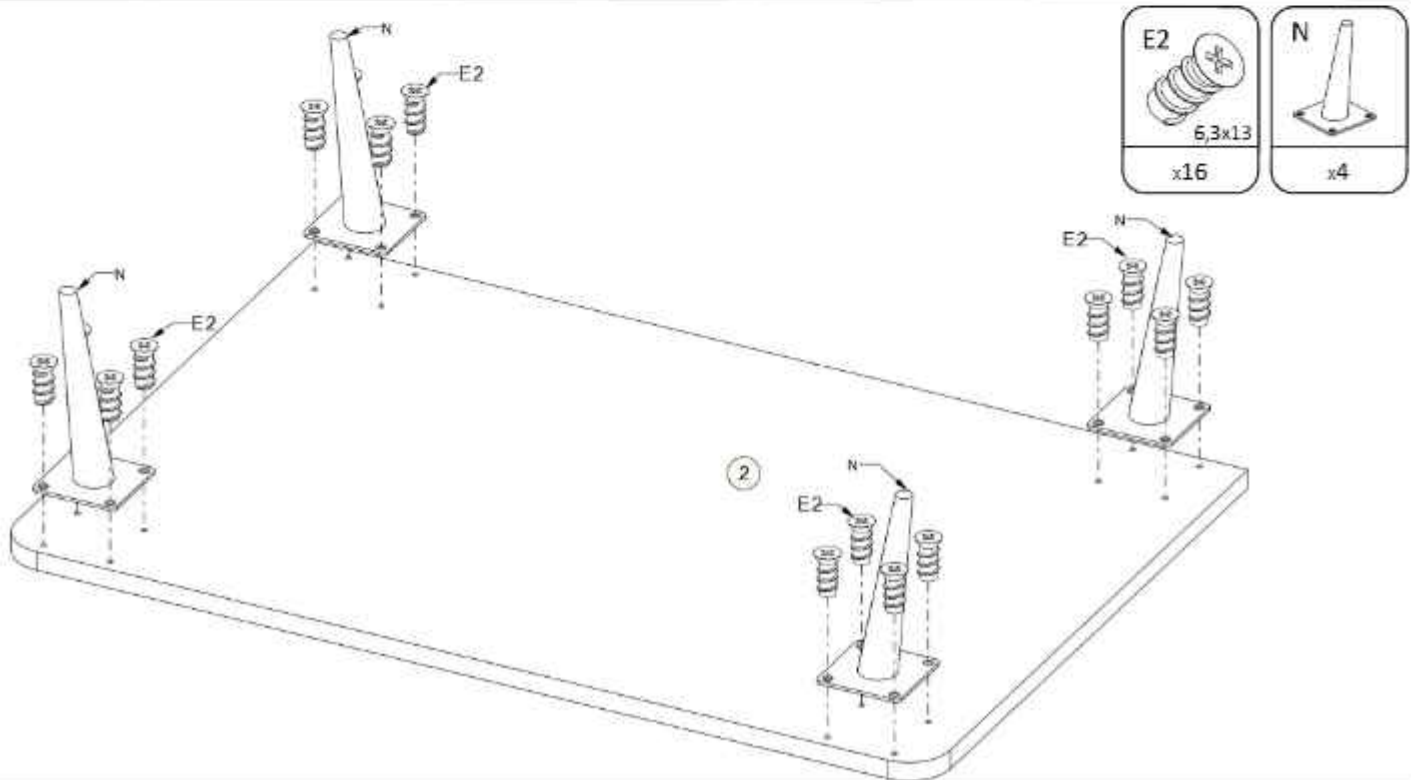

4

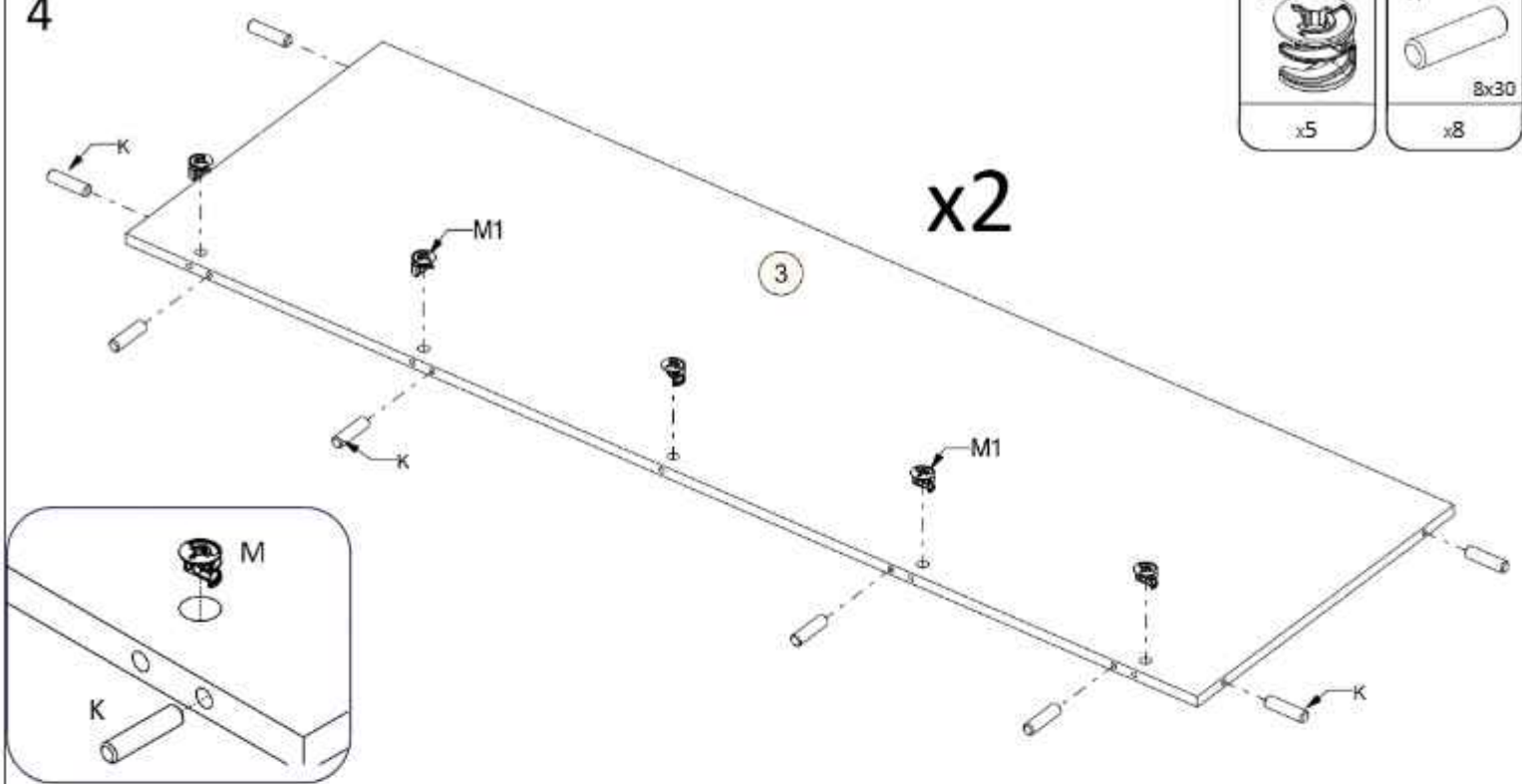
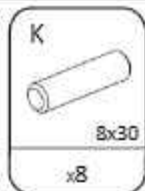
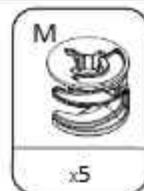

5

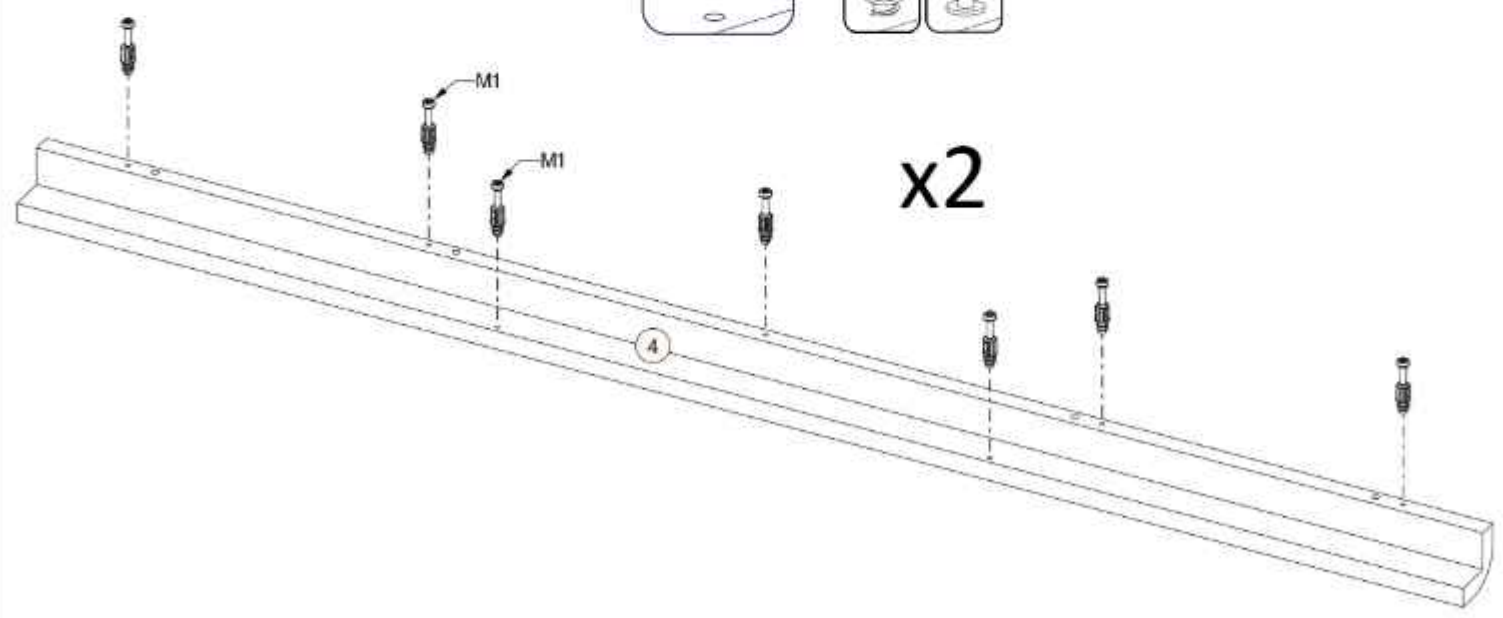

6

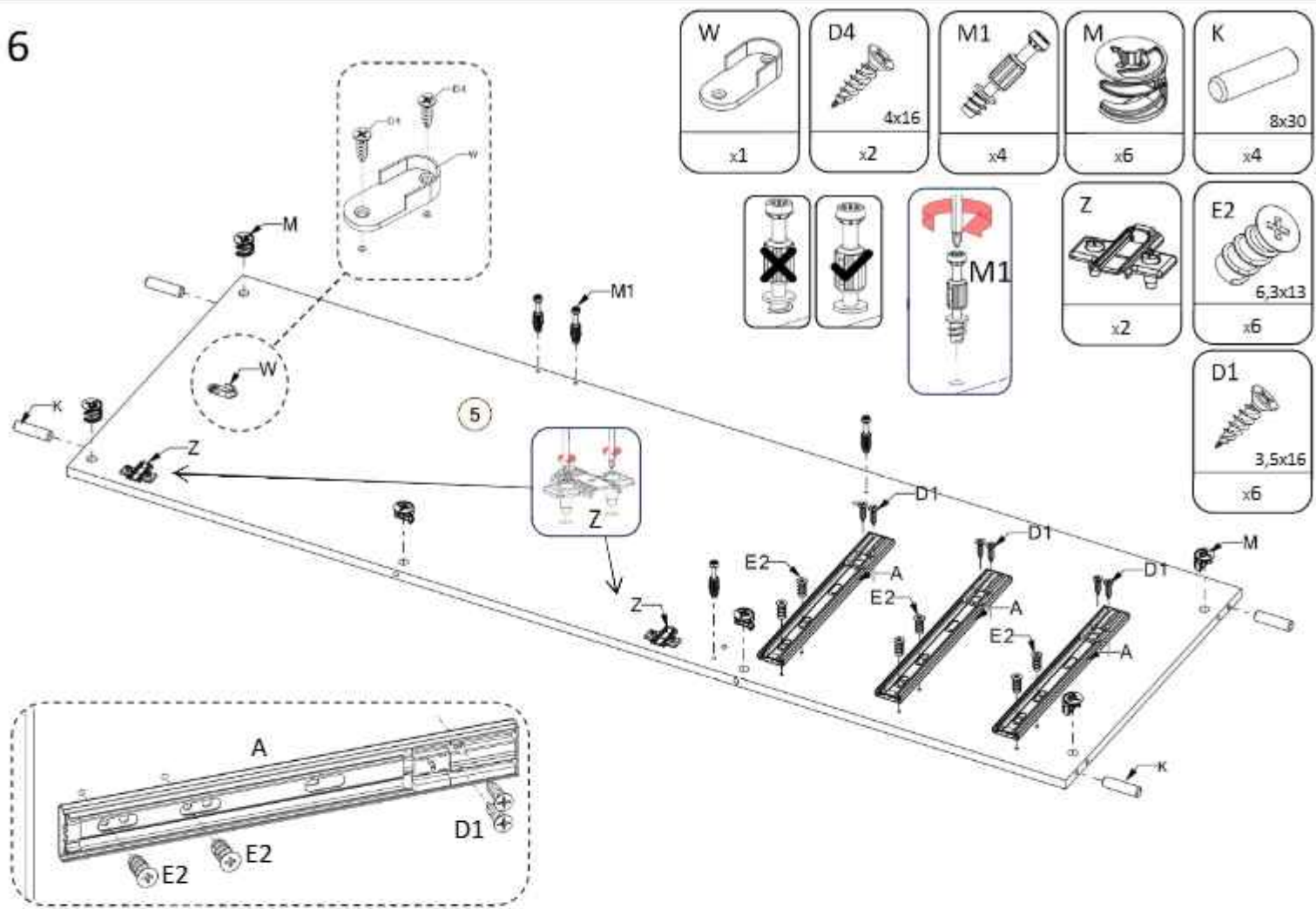

7

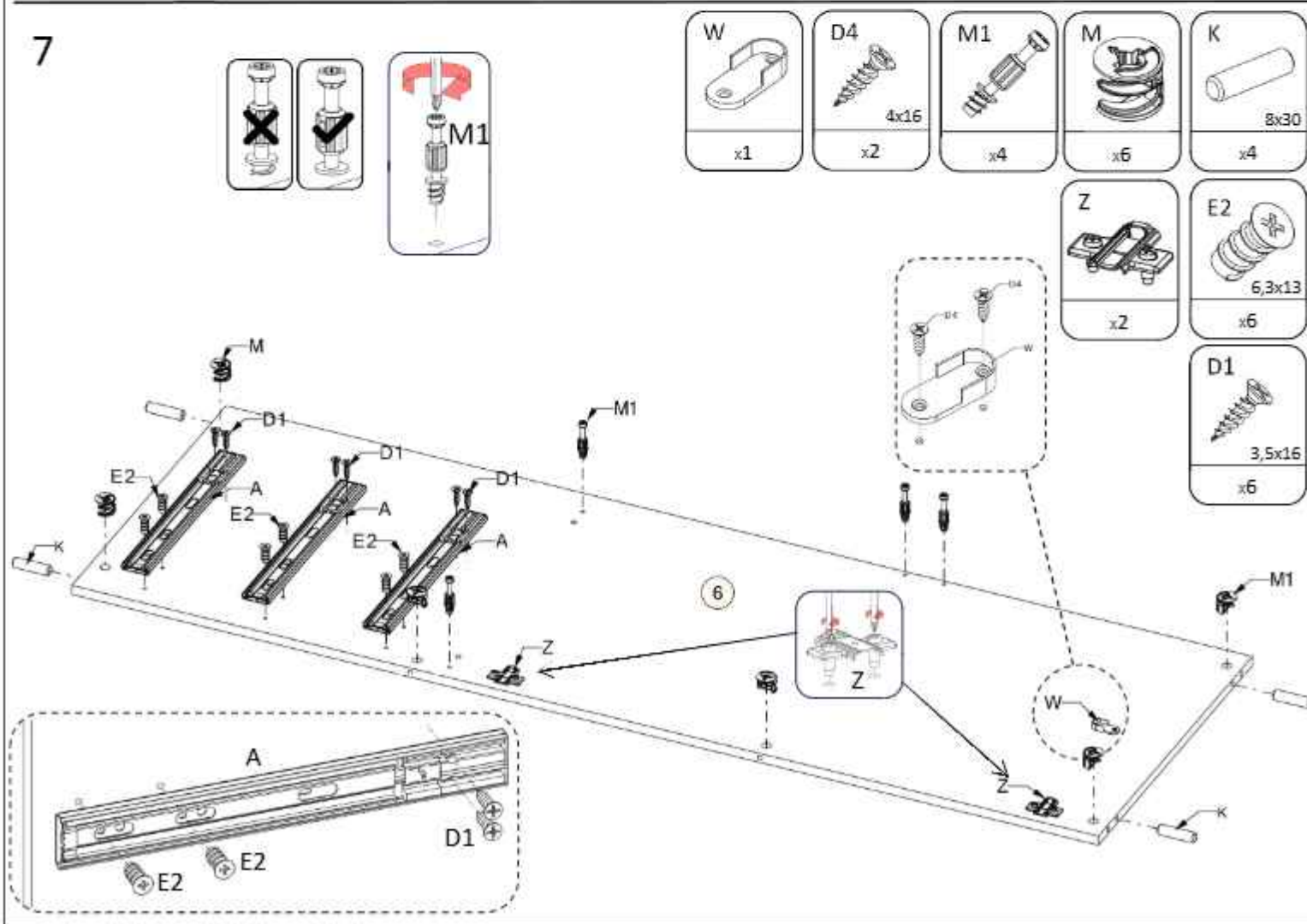

8

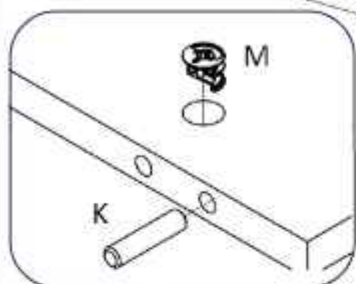
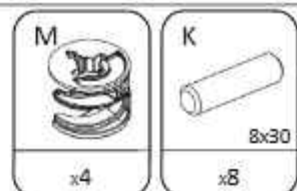
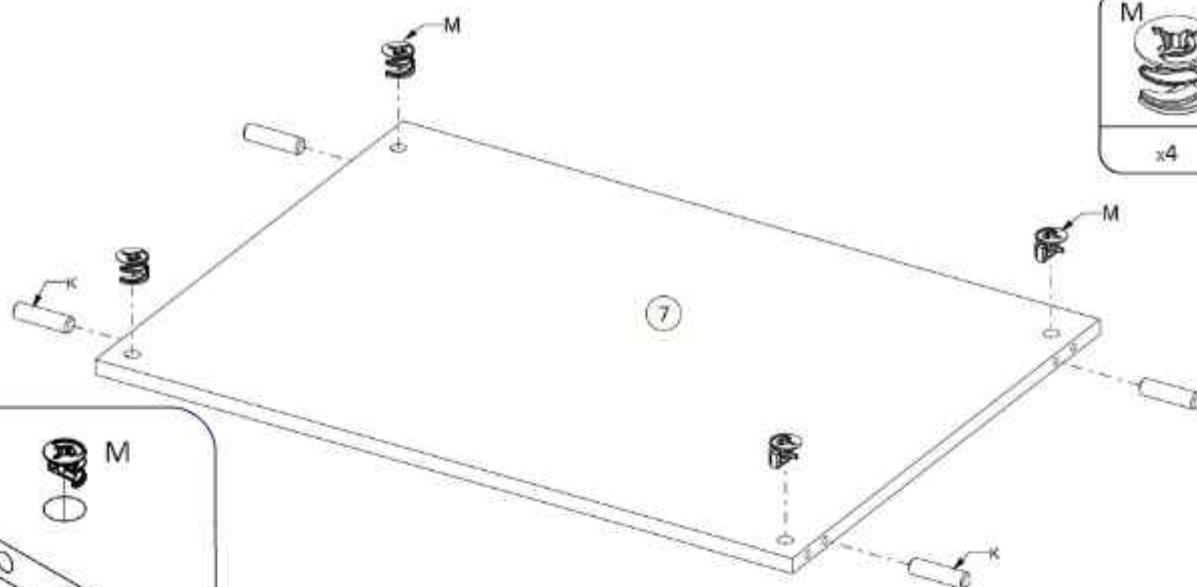

9

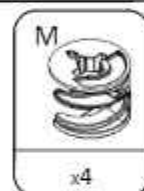
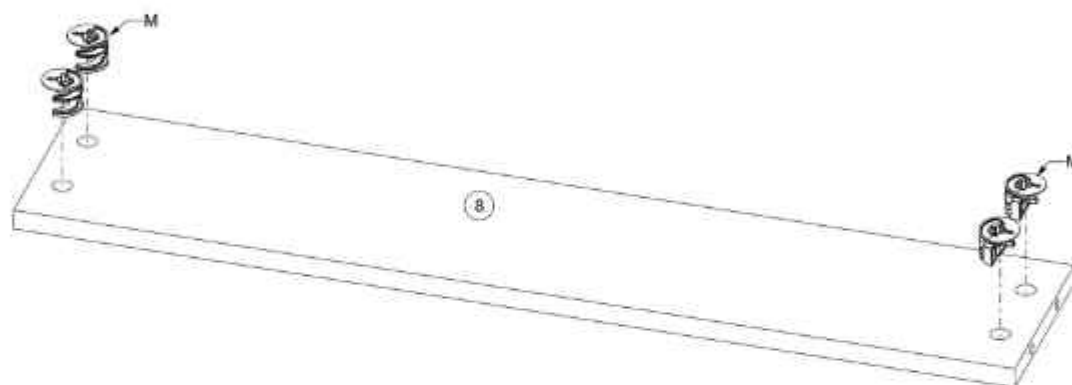

10

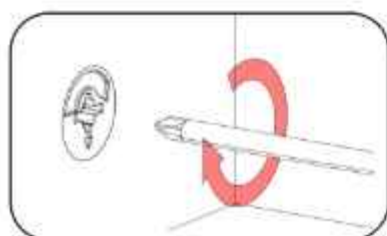
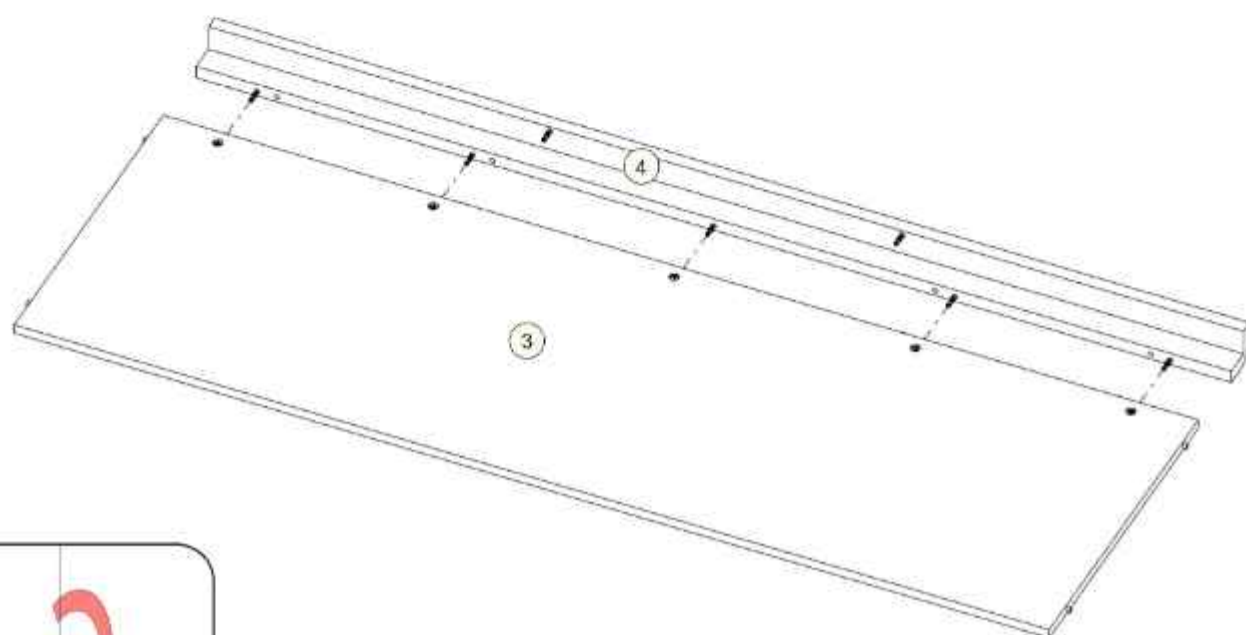

11

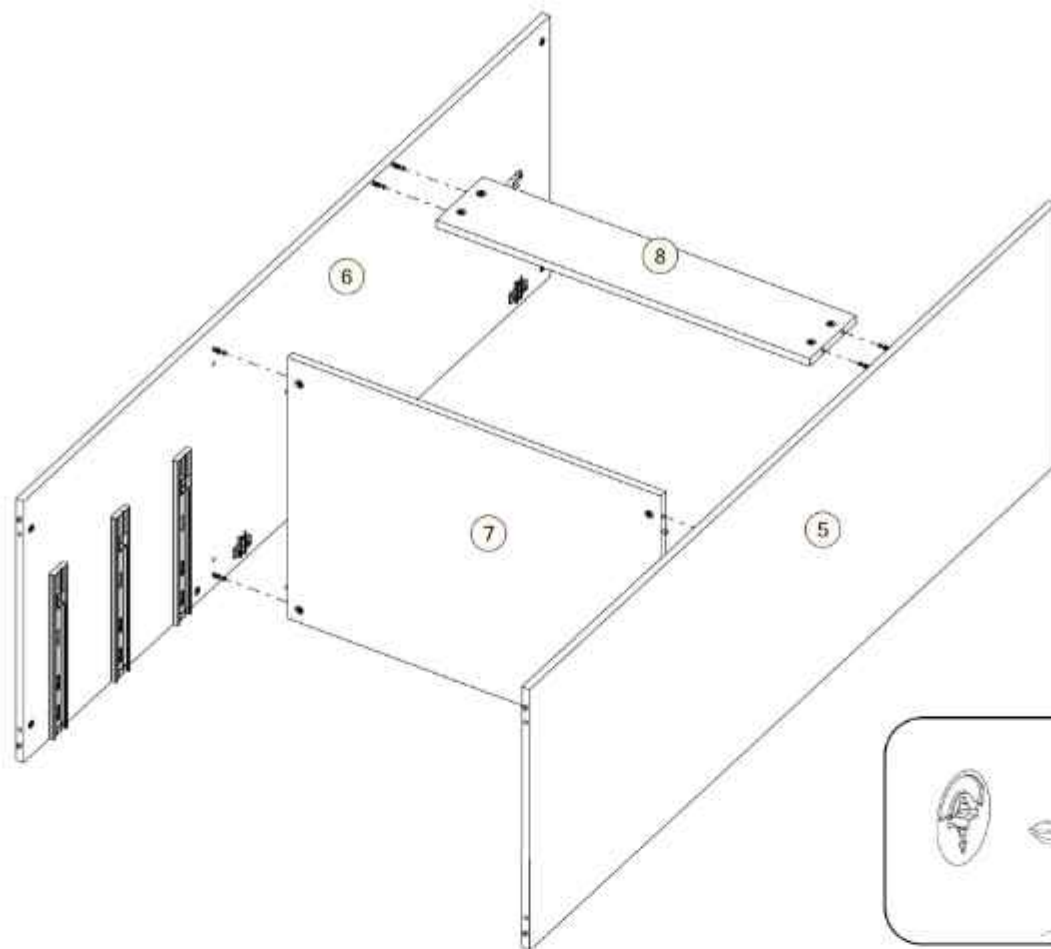

12

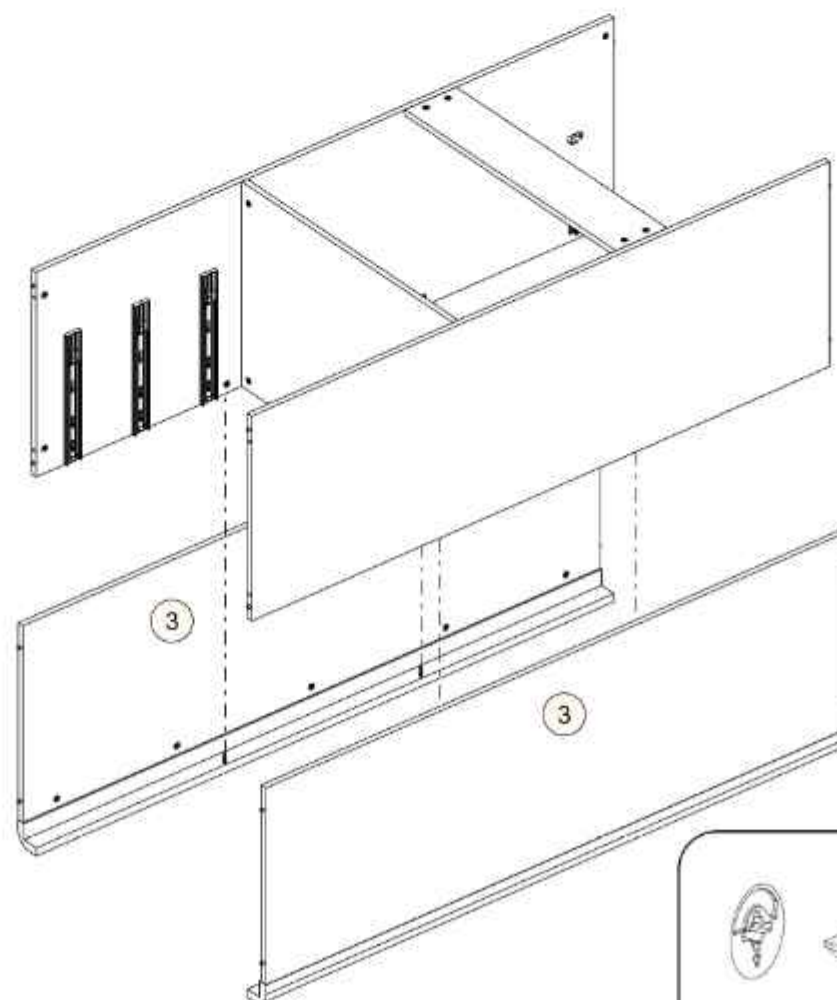

13

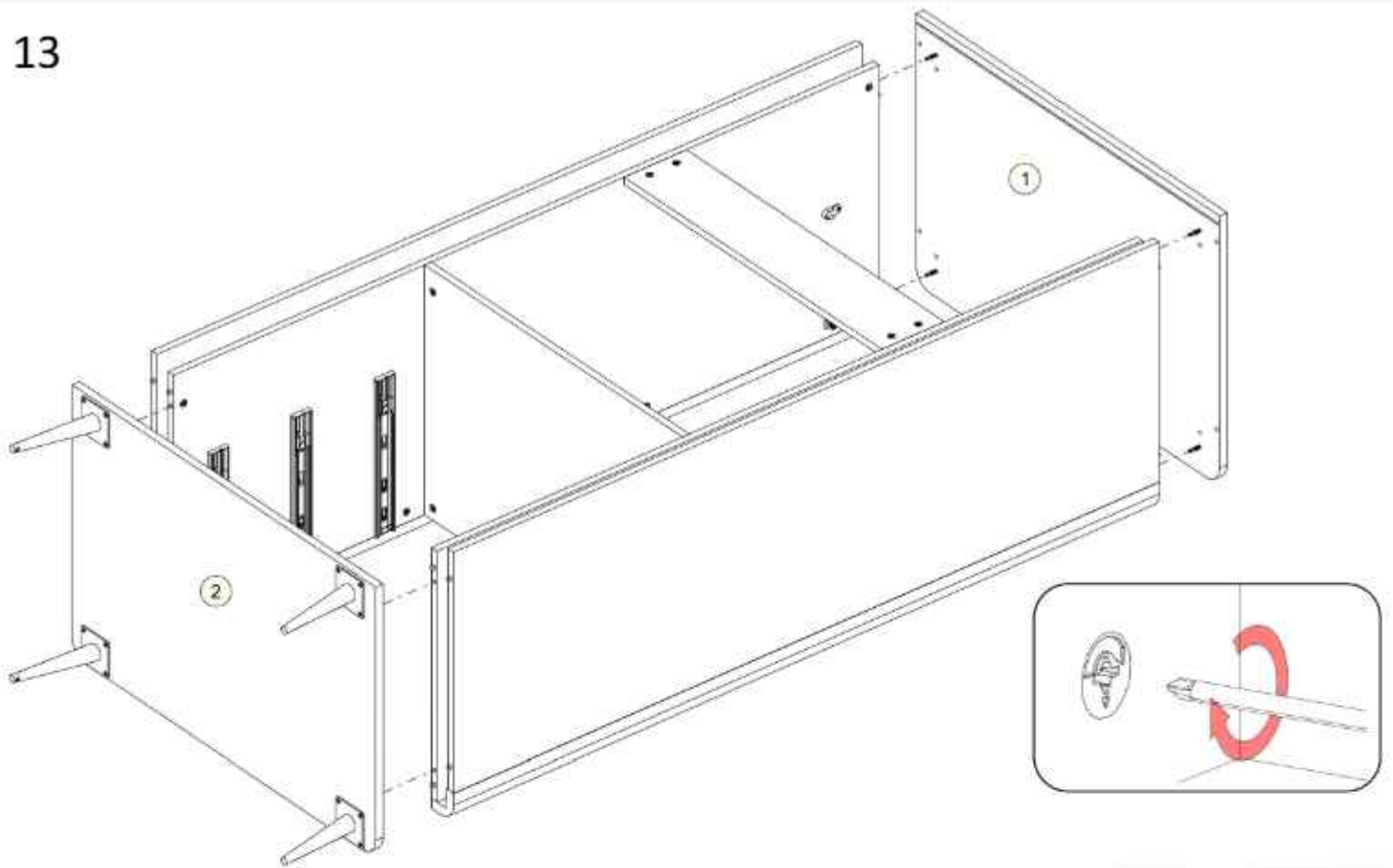

14

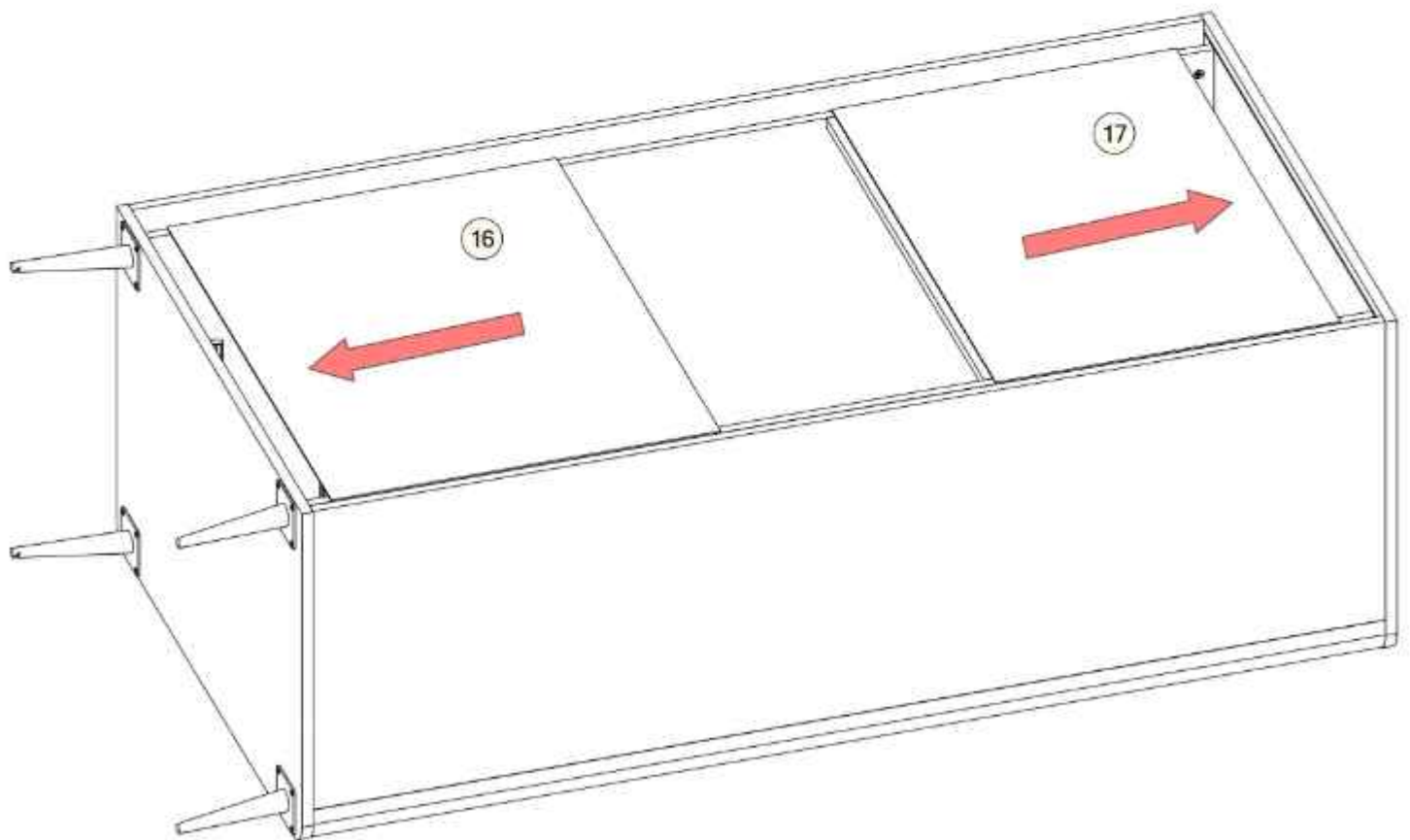

15

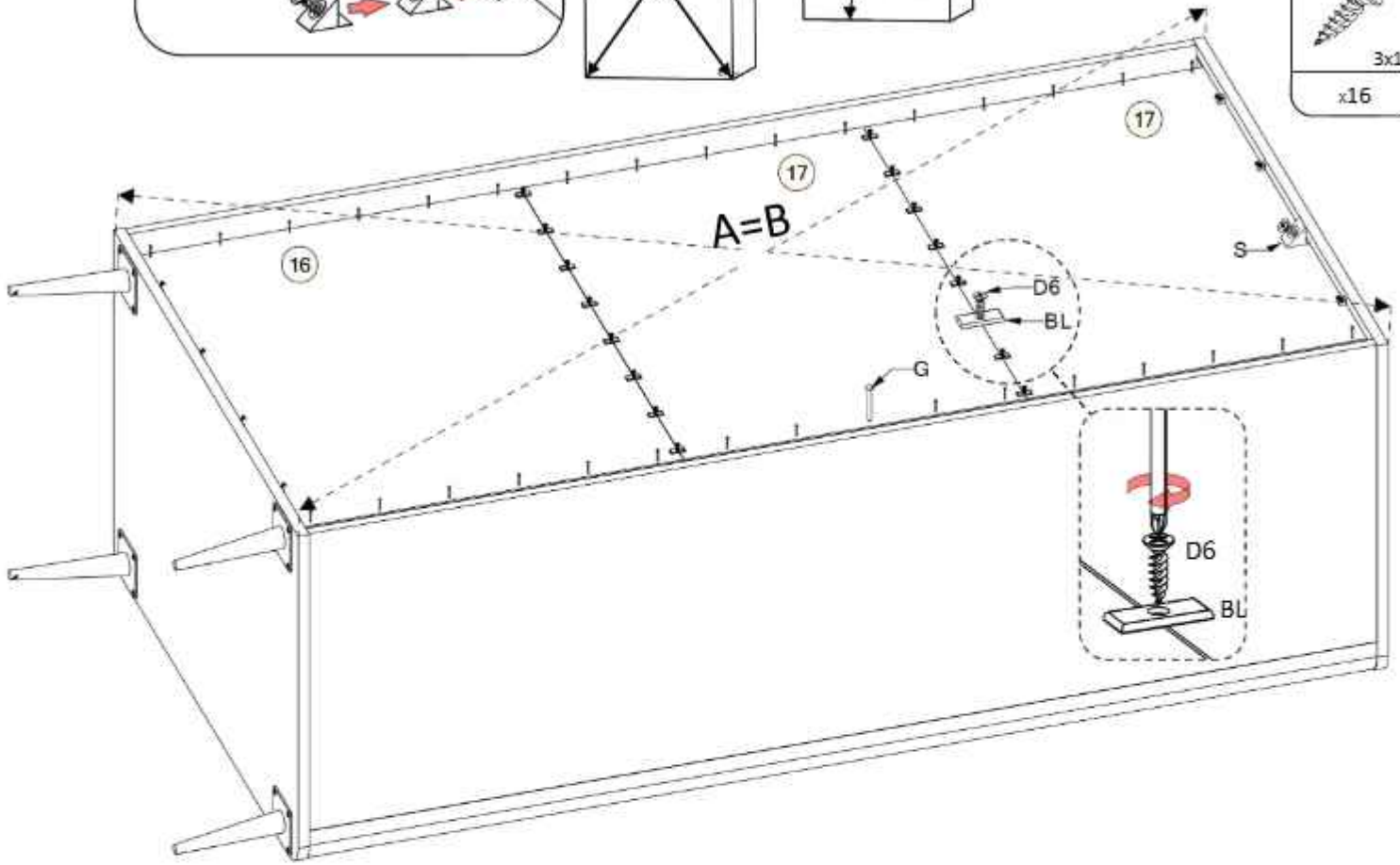
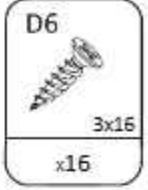
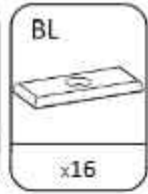
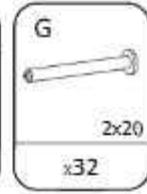
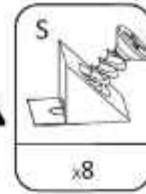
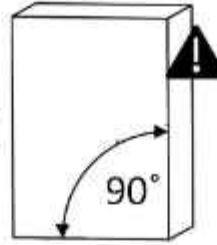
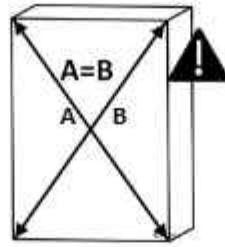
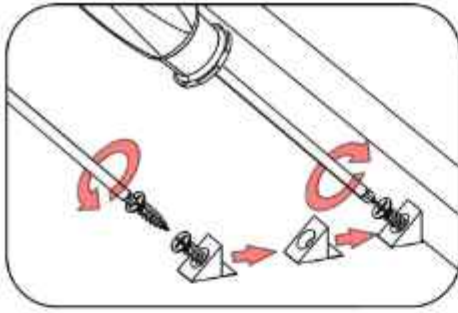

16

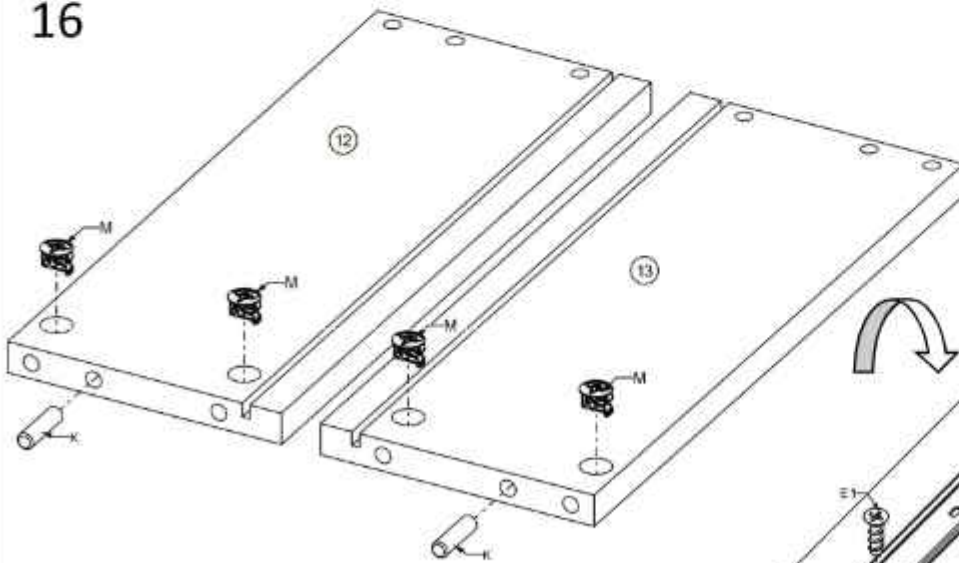

x3

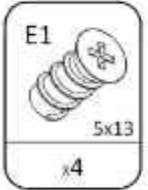
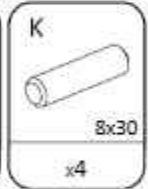
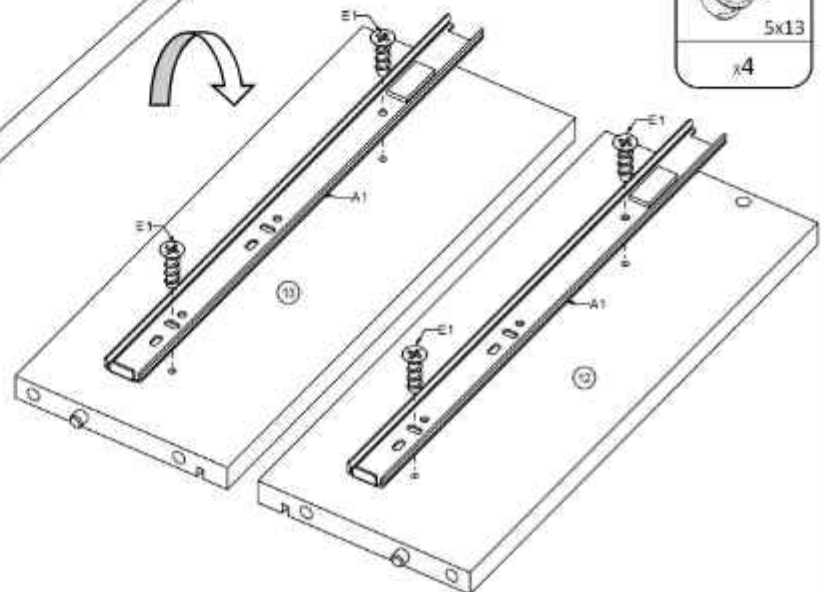

17

x3

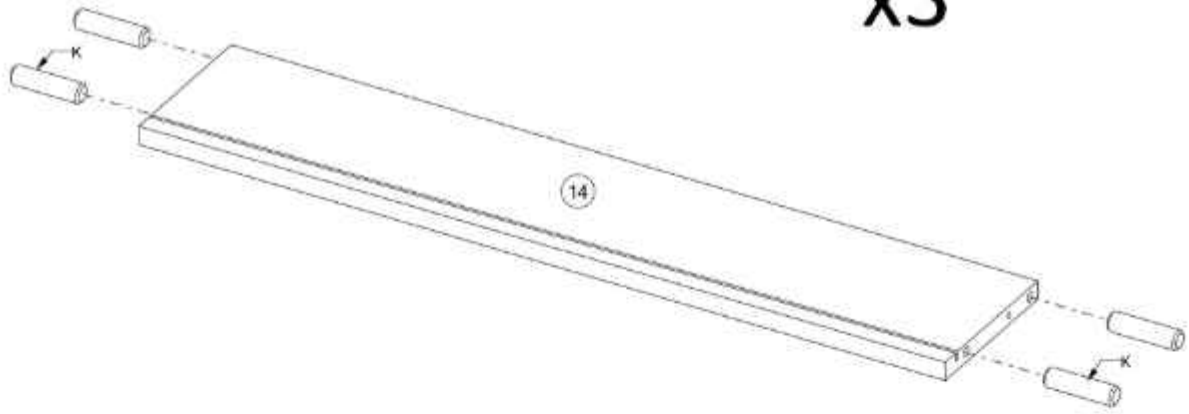
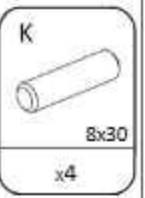

18

x2

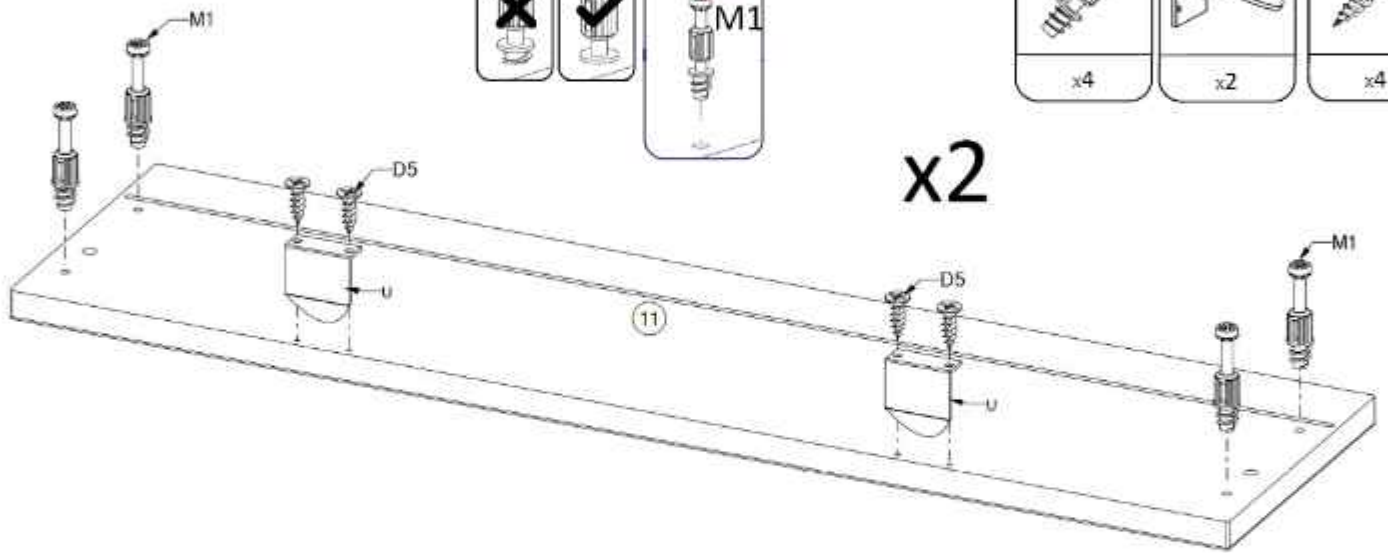
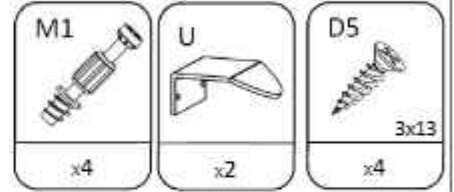
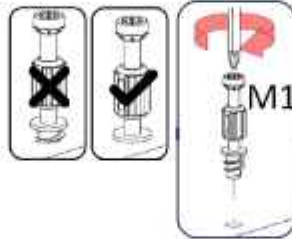

19

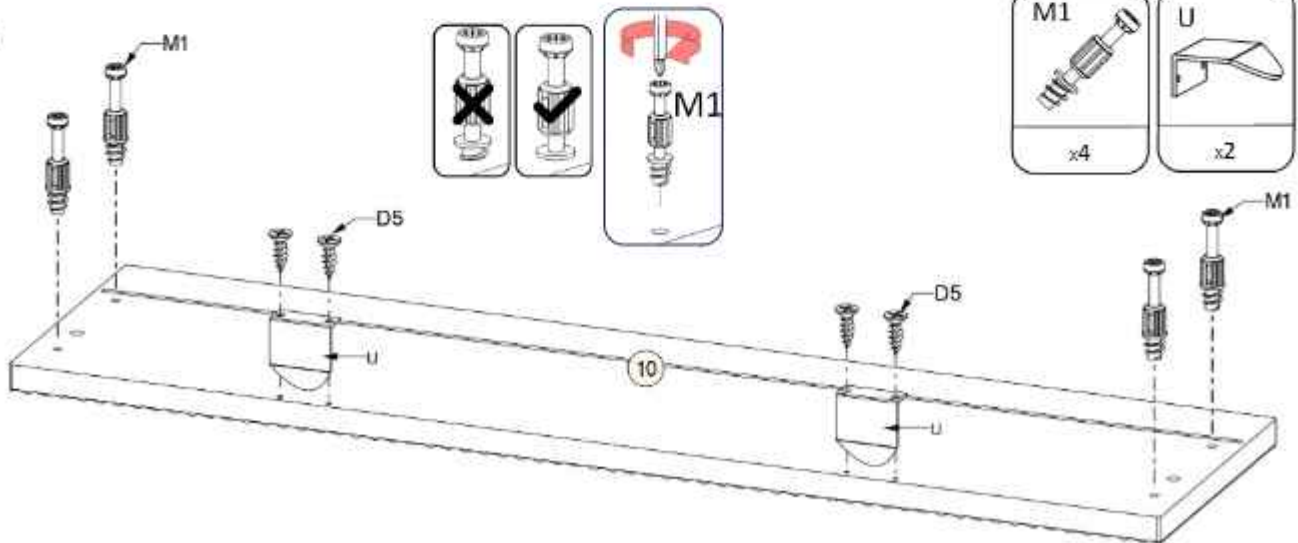
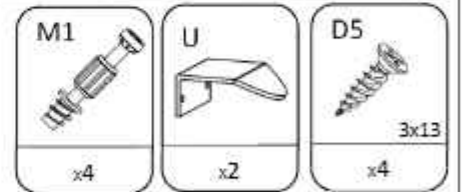

20

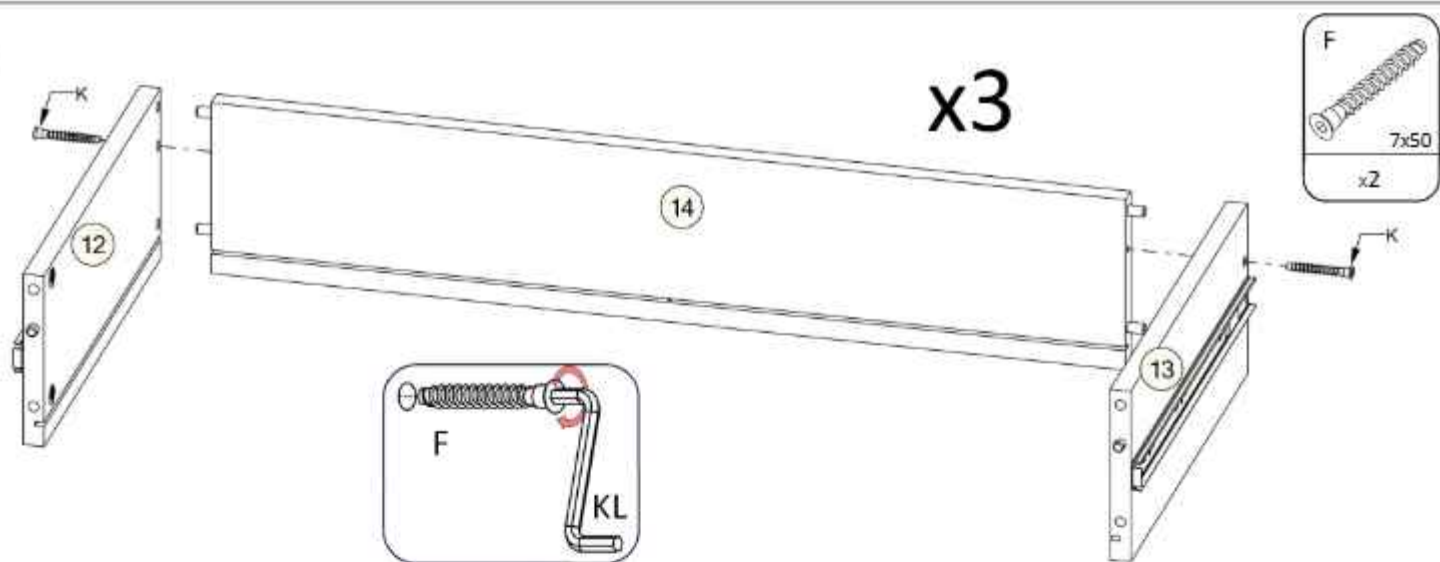

21

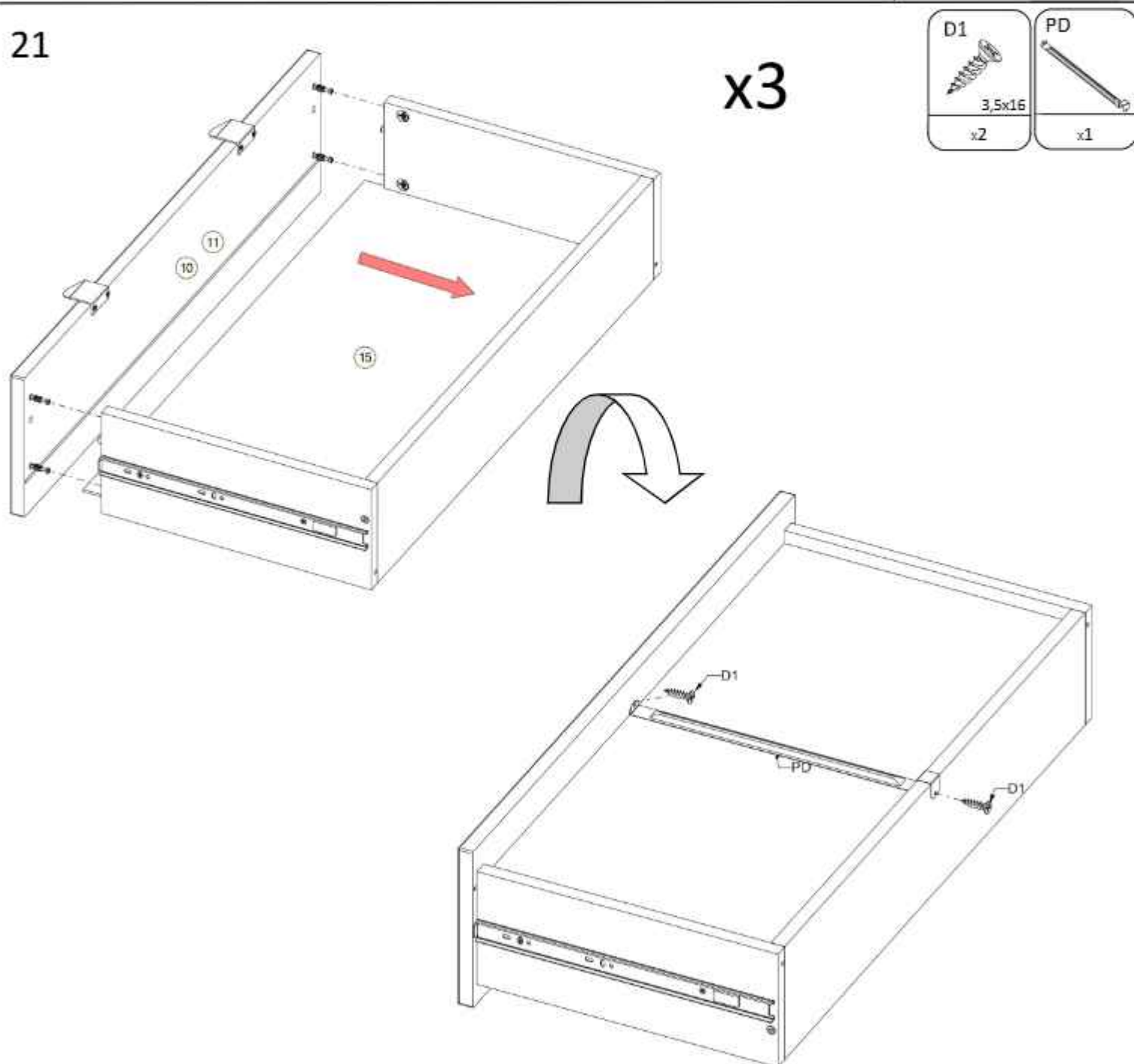

22

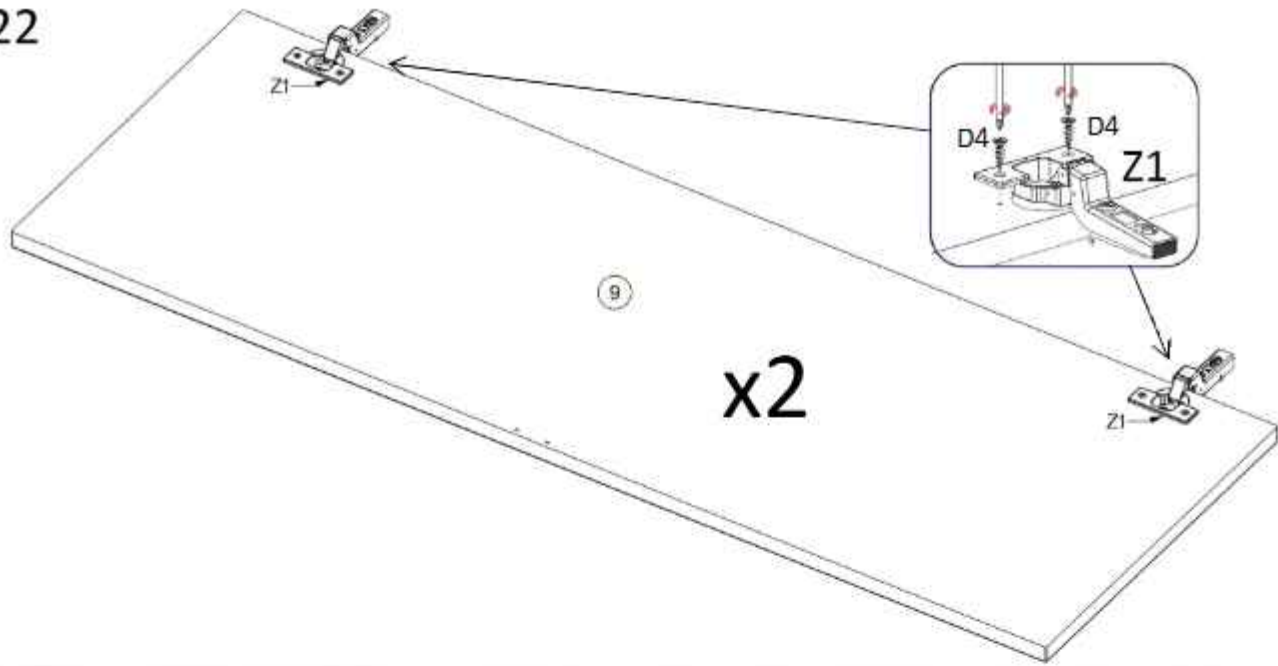

Z1



x2

D4



4x16

x4

23

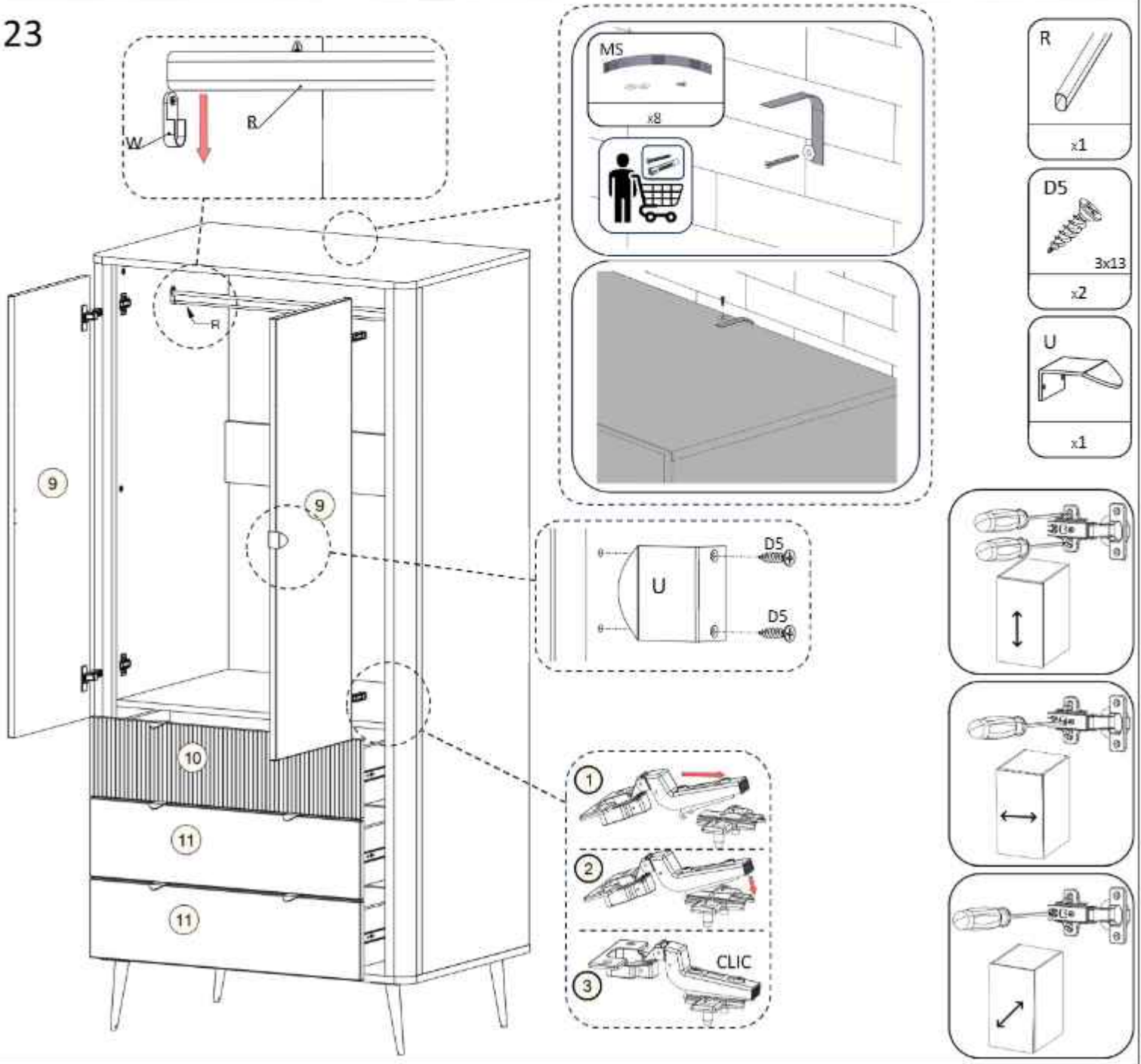

R



x1

D5



3x13

x2

U



x1

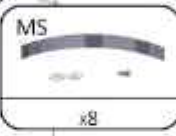

x8

