

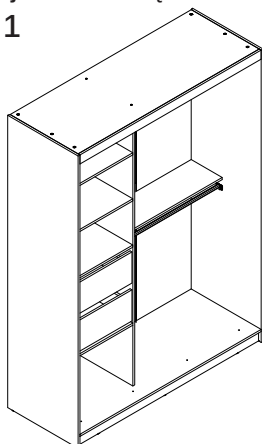

## Szafa przesuwna 160 dwudrzwiowa (157,6x216x60)

Wersja z szufladą  
ver 1



Wersja bez szuflady  
ver 2

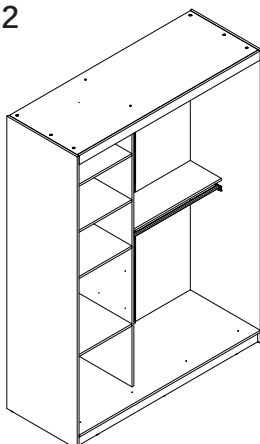

Wersja z koszami technorattanowymi  
ver 3

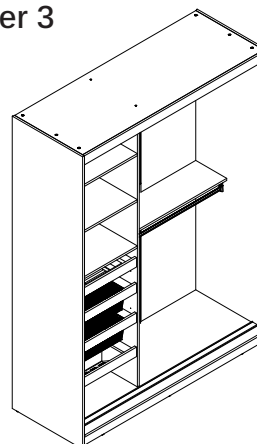

Ilość potrzebnych osób  
Number of people needed

Benötigte Personenzahl

Nombre de personnes nécessaires

Počet potrebných osob

Počet potrebných osôb

Szükséges személyek száma

Niezbędne narzędzia do montażu

Tools necessary for assembly

Notwendiges Werkzeug für die Montage

Outils nécessaires pour le montage

Potřebné nástroje pro montáž

Potřebné nástroje na montáž

Az összeszereléshez szükséges szerszámok

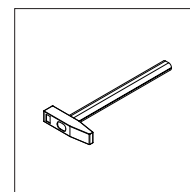
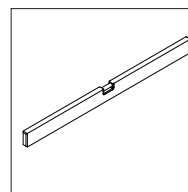
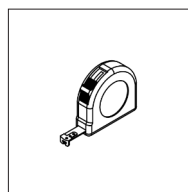
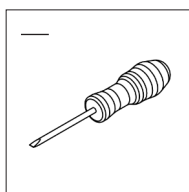
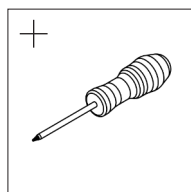

PL

- Przed przystąpieniem do montażu przeczytaj i zapoznaj się z całą instrukcją.
- Przestrzegaj bezwzględnie kolejnych kroków montażowych [1],[2],[3]...
- Nie wyrzucaj opakowania dopóki nie ukończysz skutecznie w całości montażu.
- Montaż wykonuj na płaskiej, miękkiej oraz czystej powierzchni takiej jak tektura.
- Bezwzględnie nie montuj elementów jeśli zauważysz ich wady lub uszkodzenia.
- Elementy montażowe takie jak okucia trzymaj w miejscu niedostępnym dla niemowląt i dzieci.
- Wadliwe lub uszkodzone elementy reklamuj podając ich numer z instrukcji montażu.
- Jeśli uszkodzony element będzie zamontowany reklamacja nie będzie uznana.

EN

- Read and get familiar with the whole instruction before the process of installation.
- Imperatively observe the consecutive assembly steps [1],[2],[3]...
- Do not throw away the packaging until the installation is successfully done.
- The installation should be done on the flat, soft and clear surface, such as cardboard.
- Under no circumstances should you install the elements in case of any faults or damage.
- The installation elements as fittings should be kept in a place unavailable for babies or children.
- Faulty or damaged components should be complaint by giving the number of the assembly instruction.
- If the damaged component is installed, the complaint will not be accepted.

DE

- Vor Beginn der Montage muss man die Instruktion genau durchlesen.
- Die aufeinanderfolgenden Montageschritte [1],[2],[3]... unbedingt beachten.
- Man muss die Packung behalten bis man die ganze Montage erfolgreich nicht beendet.
- Die Montage muss man auf einer glatten, weichen und sauberen Fläche ausüben
- Fehlerhafte oder beschädigte Elemente darf man auf keinen Fall montieren. Auf keinen Fall darf man fehlerhafte oder beschädigte Elemente montieren.
- Die Montageelemente wie Beschläge muss man unzugänglich von Babys und Kindern halten.
- Fehlerhafte oder beschädigte Elemente muss man nur mit Nummer der Instruktion reklamieren.
- Falls das beschädigte Element montiert wird, wird die Reklamation nicht berücksichtigt.

FR

- Avant de commencer le montage, lire et prendre connaissance de l'intégralité du manuel.
- Respectez scrupuleusement les étapes d'installation suivantes [1](#), [2](#), [3](#)...
- Ne pas jeter l'emballage avant d'avoir terminé l'assemblage.
- Le montage doit être effectué sur une surface plane, souple et propre, comme du carton.
- Ne pas assembler si vous remarquez des défauts ou des dommages.
- Garder les éléments de montage tels que les raccords hors de portée des bébés et des enfants.
- Réclamer les pièces défectueuses ou endommagées en citant le numéro figurant dans les instructions de montage.
- Si l'article endommagé est installé, la plainte ne sera pas acceptée.

CZ

- Před zahájením montáže si přečtete celý návod k montáži.
- Dodržujte všechny kroky montáže postupně [1](#), [2](#), [3](#)...
- Nevyhazujte obaly nábytku dokud nedokončíte úspěšně celou montáž.
- Montáž provádějte na plochem, měkkém a čistém povrchu jako je tektura.
- Nepokračujte v montáži pokud zjistíte chyby částí, nebo jejich poškození.
- Montážní části jako jsou kování skladujte mimo dosah dětí a kojenců.
- Chybné a poškozené části reklamujte prostřednictvím uvedení jejich čísla z návodu k montáži.
- Pokud bude poškozená část již po montáži, reklamáce nebude uznána.

SK

- Pred začatím montáže si prečítajte celý návod na montáž.
- Dodržiavajte všetky kroky montáže postupne [1](#), [2](#), [3](#)...
- Nevyhadzujte obaly nabytku pokiaľ nedokončíte úspešne celú montáž.
- Montáž vykonávajte na plochom, mäkkom a čistom povrchu ako je tektúra.
- Nepokračujte v montáži ak zistíte chyby častí, alebo ich poškodenia.
- Montážne časti ako sú kovania skladujte mimo dosah detí a dojčiat.
- Chybné a poškodené časti reklamujte prostredníctvom uvedenia ich čísla z návodu na montáž.
- Ak bude poškodená časť už po montáži, reklamácia nebude uznaná.







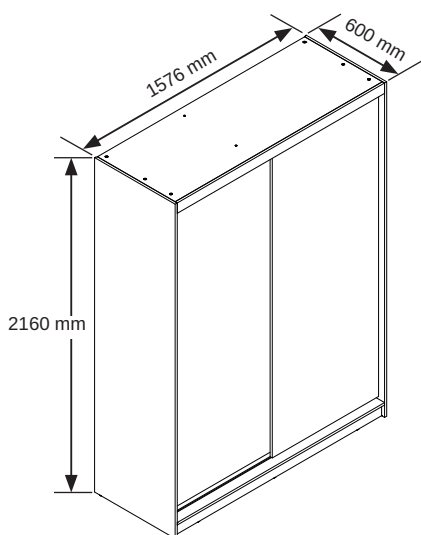





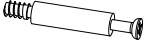



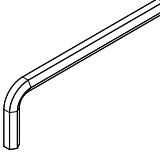

HU

- Az összeszerelés megkezdése előtt olvassa el a teljes összeszerelési útmutatót.
- Kövesse az összeszerelési lépést egymás után [1](#), [2](#), [3](#)...
- Ne dobja ki a termék csomagolását, amíg a teljes összeszerelést sikeresen be nem fejezte.
- Szerelje fel lapos, puha és tiszta felületre, például kartonra.
- Ne folytassa az összeszerelést, ha hibát vagy sérülést talál az alkatrészekben.
- A rögzítőelemeket, például a szerelvényeket gyermekektől és csecsemőktől elzárva tárolja.
- Hirdesse a hibás és sérült alkatrészeket a számuk megadásával az összeszerelési útmutatóban.
- Ha az alkatrész az összeszerelés után megsérül, a reklamációt nem fogadjuk el.

# SZAFKA PRZESUWNA 160

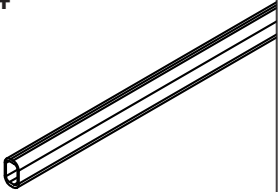
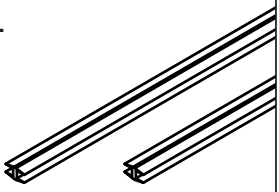

Okucia / Fittings / Beschläge / Embouts  
Kováni / Kovania / Szerelvények bútorokhoz

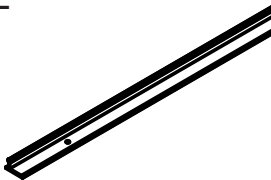
		N4	M5
		 PZ2 x4	 x4
		N2	M3
		 PZ2 x19	 x19
E1	Z2	F1	P9a
 x36	 x8	 7x50mm x5	 3x13mm PH1 ver1 x42 / ver2 x42 / ver3 x26
S1c	P9c	K2	S0b
 3,5x16mm PZ2 x8	 5x16mm PZ2 x16	 x1	 3x16mm PH1 x66
M2	L1	T1	W3
 x11	 x6	 x7	 ver1 x4 / ver2 x4 / ver3 x0
W4	H1	D5	R2
 ver1 x2 / ver2 x2 / ver3 x0	 x2	 x8	 x2

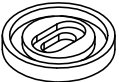
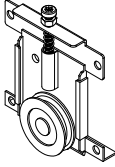
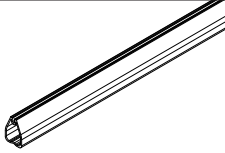
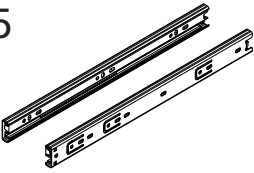
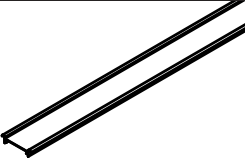
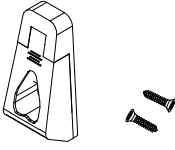
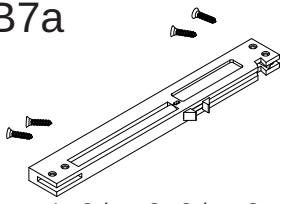
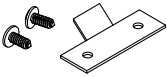
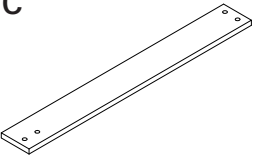
<b>F10</b>  x5	<b>R7</b>  x4	<b>R5g</b>  x8	<b>W9</b>  ver1 x0 / ver2 x0 / ver3 x2
<b>J5</b>  ver1 x2 / ver2 x0 / ver3 x0	<b>R8</b>  x1	<b>W8</b>  ver1 x0 / ver2 x0 / ver3 x4	<b>B7a</b>  ver1 x0 / ver2 x0 / ver3 x4
<b>B7b</b>  ver1 x0 / ver2 x0 / ver3 x4	<b>B7c</b>  ver1 x0 / ver2 x0 / ver3 x4		

Sposób montażu elementów N2 i M3  
Method of assembling elements N2 and M3  
Art der Montage von Elementen N2 und M3  
Méthode d'assemblage de composants N2 et M3

Způsob montáže částí N2 a M3  
Spůsob montáže částí N2 a M3  
Az N2 és M3 alkatrészek összeszerelésének módja

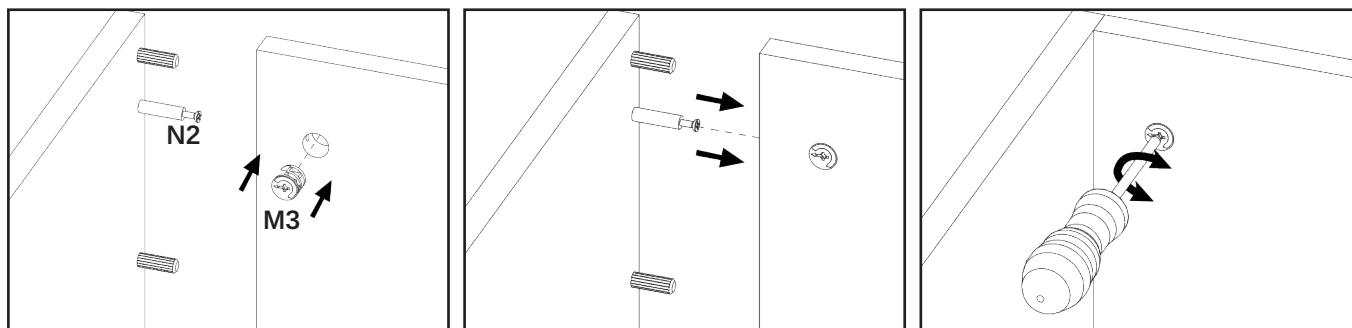

Sposób montażu elementów N4 i M5  
Method of assembling elements N4 and M5  
Art der Montage von Elementen N4 und M5  
Méthode d'assemblage de composants N4 et M5

Způsob montáže částí N4 a M5  
Spůsob montáže částí N4 a M5  
Az N4 és M5 alkatrészek összeszerelésének módja

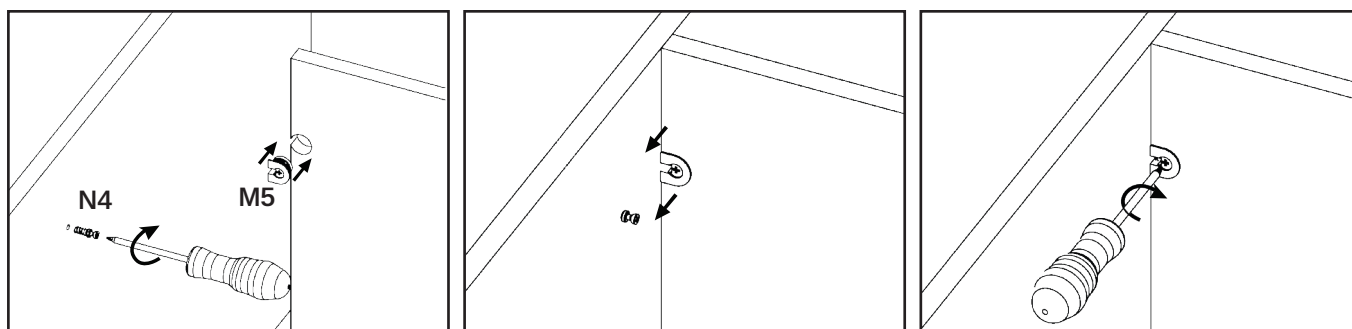

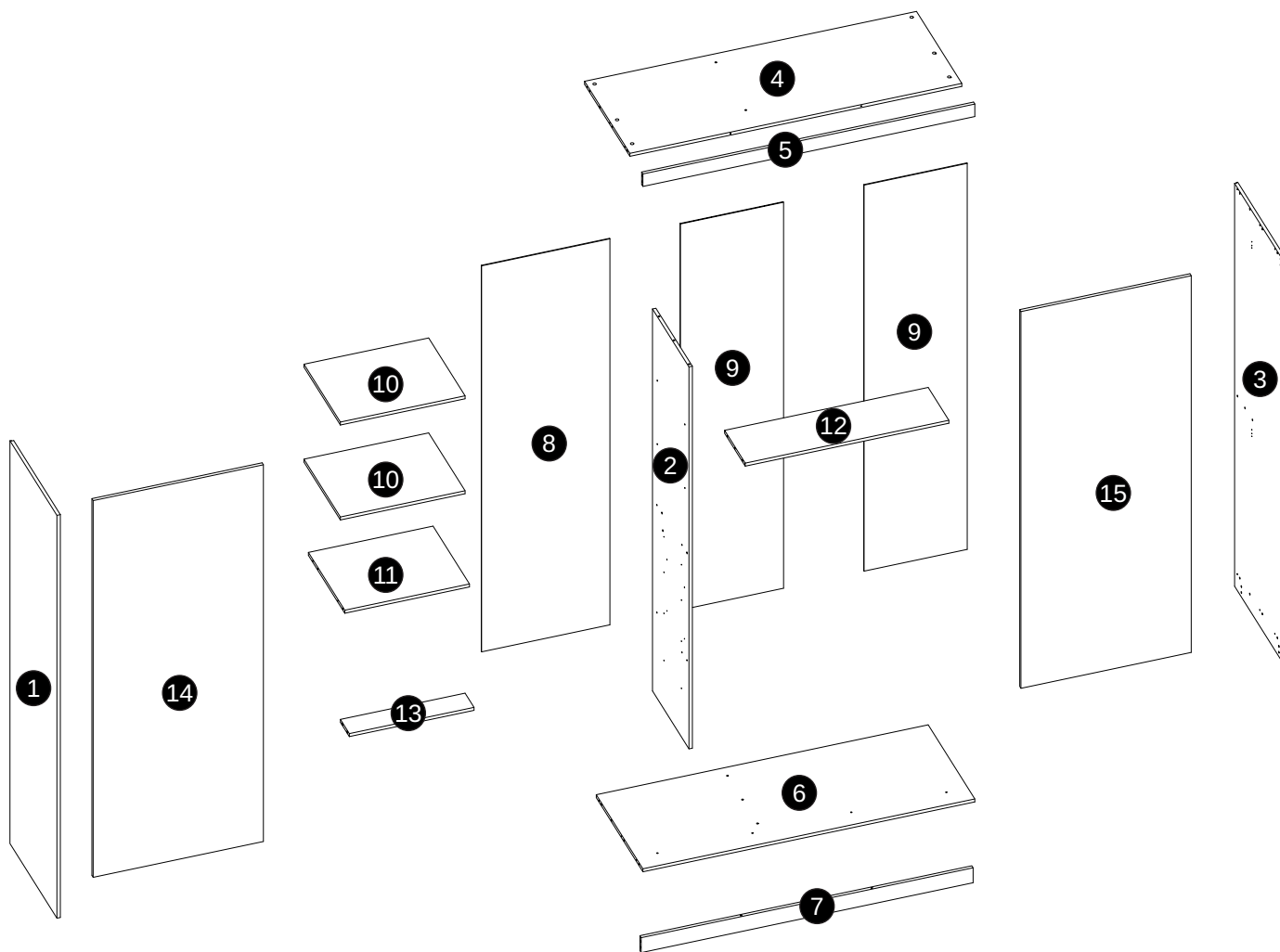

### SZAFKA PRZESUWNA 160

①	1x (2160x600mm)	⑦	1x (1543x80mm)	⑬	1x (ver 1 - 580x114 / ver 2 - 580x465mm / ver 3 - X)
②	1x (2048x466mm)	⑧	1x (597x2070mm)	⑭	1x (792x2020mm)
③	1x (2160x600mm)	⑨	2x (480x2070mm)	⑮	1x (792x2020mm)
④	1x (1544x579mm)	⑩	2x (580x465mm)		
⑤	1x (1544x67mm)	⑪	1x (580x465mm)		
⑥	1x (1544x596mm)	⑫	1x (948x264mm)		

Patrz strona 23  
See page 23  
Siehe Seite 23  
Voir page 23

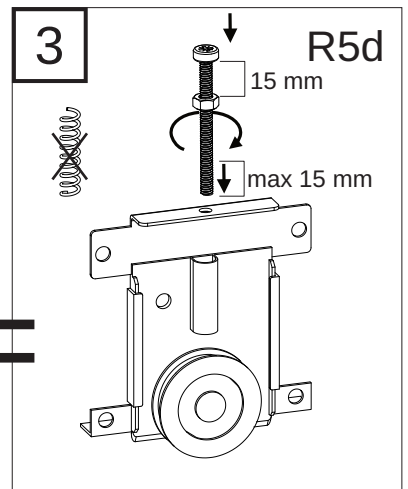
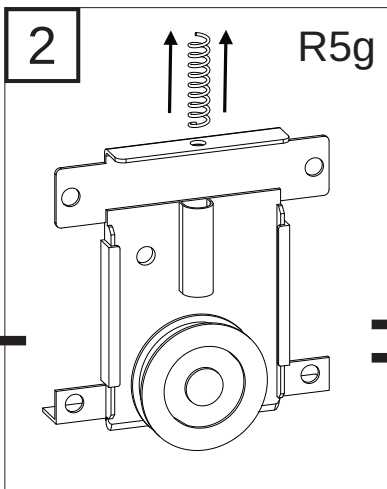
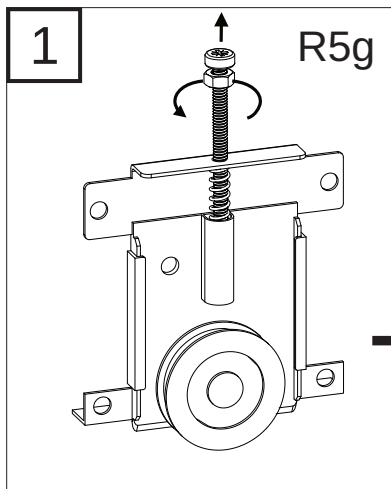
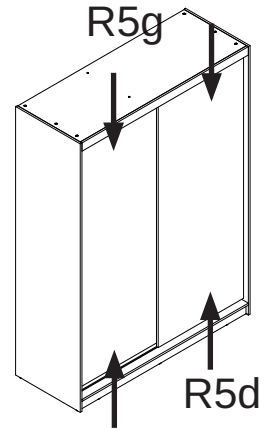
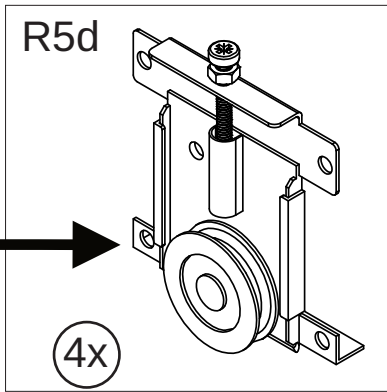
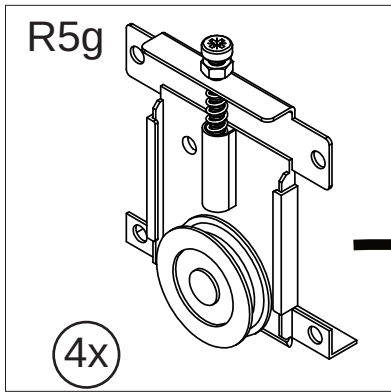

Viz strana 23  
Vid' strana 23  
Nézze meg a 23. oldalt



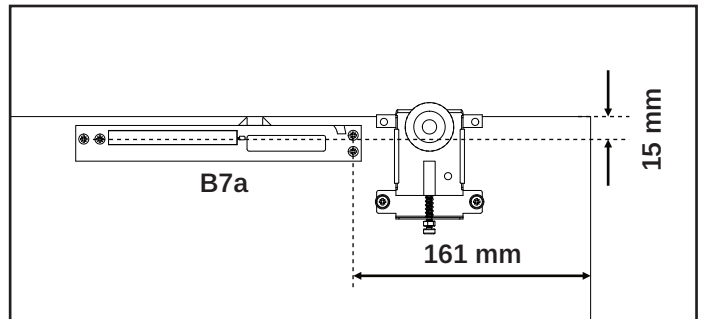
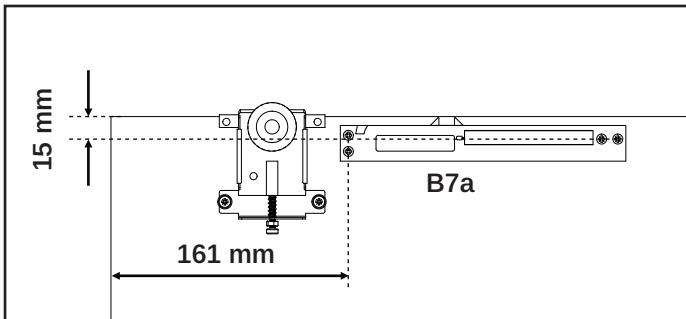

Patrz strona 24  
See page 24  
Siehe Seite 24  
Voir page 24

Viz strana 24  
Vid' strana 24  
Nézze meg a 24. oldalt



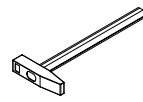

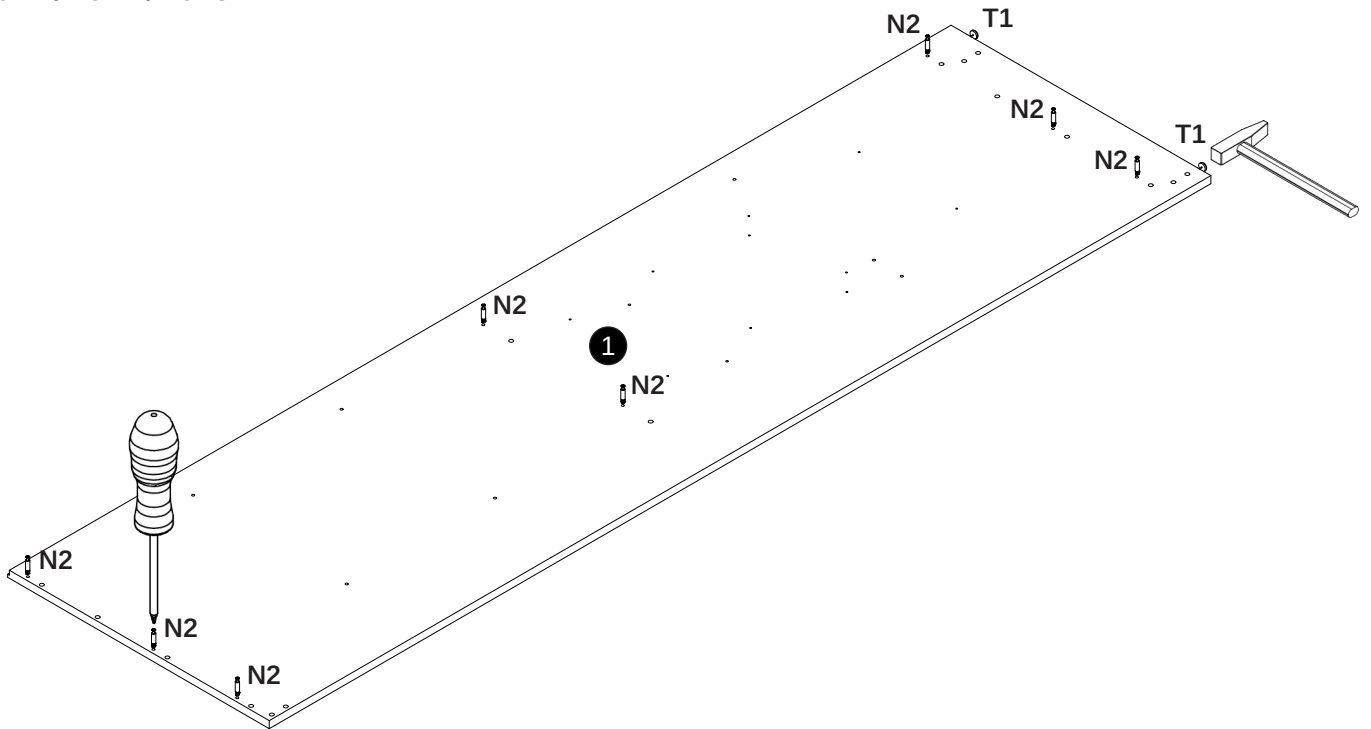

<b>1</b>	N2  8x	T1  2x
----------	-----------------------------------------------------------------------------------------------	-----------------------------------------------------------------------------------------------

	+	 PZ2
-------------------------------------------------------------------------------------	---	--------------------------------------------------------------------------------------------

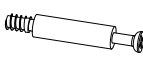
ver 1 / ver 2 / ver 3





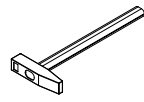

<b>2</b>	N2  7x	P9a  8x	W3  2x	+	 PH1	+	 PZ2
----------	-------------------------------------------------------------------------------------------------	--------------------------------------------------------------------------------------------------	--------------------------------------------------------------------------------------------------	---	----------------------------------------------------------------------------------------------	---	----------------------------------------------------------------------------------------------

ver 1 / ver 2

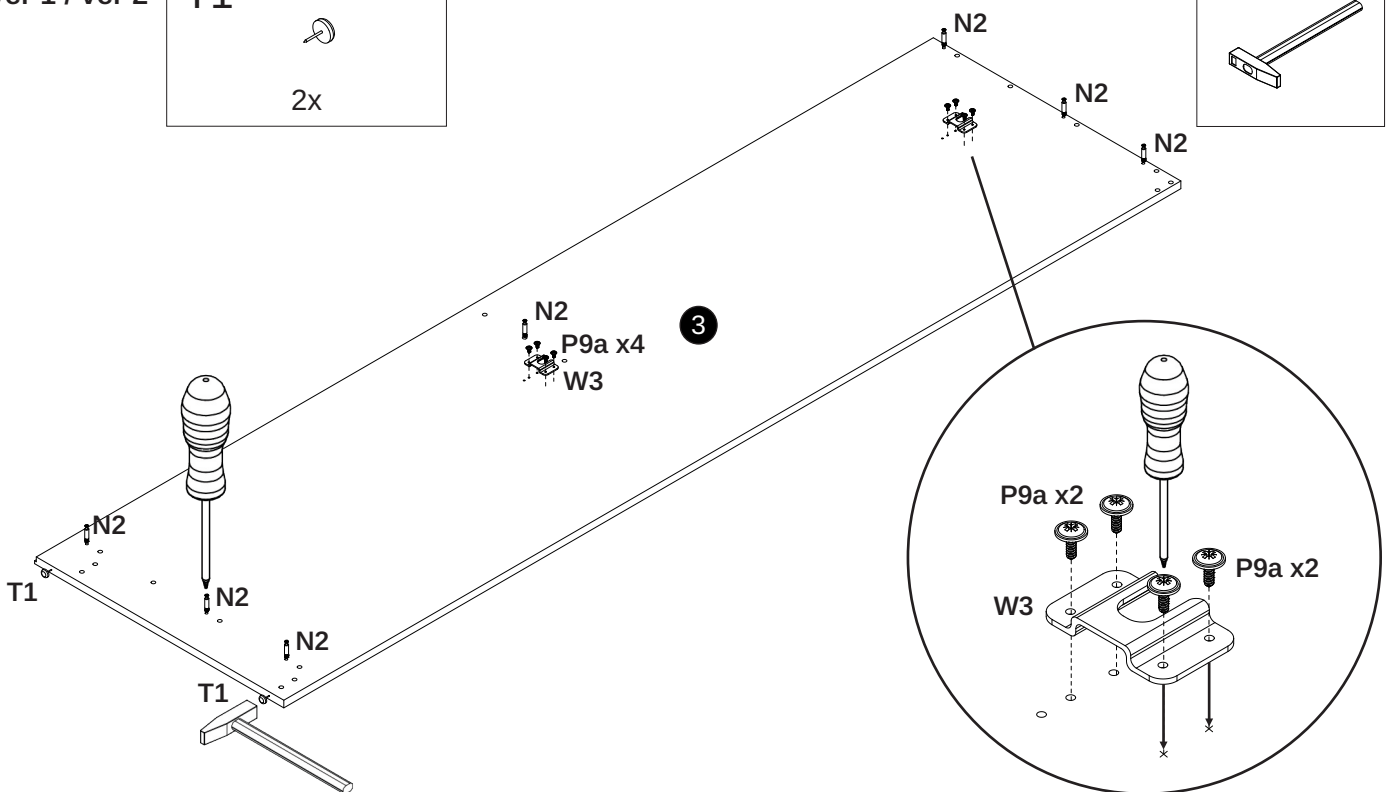
T1  2x
-------------------------------------------------------------------------------------------------

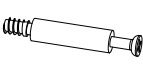

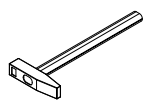

---------------------------------------------------------------------------------------

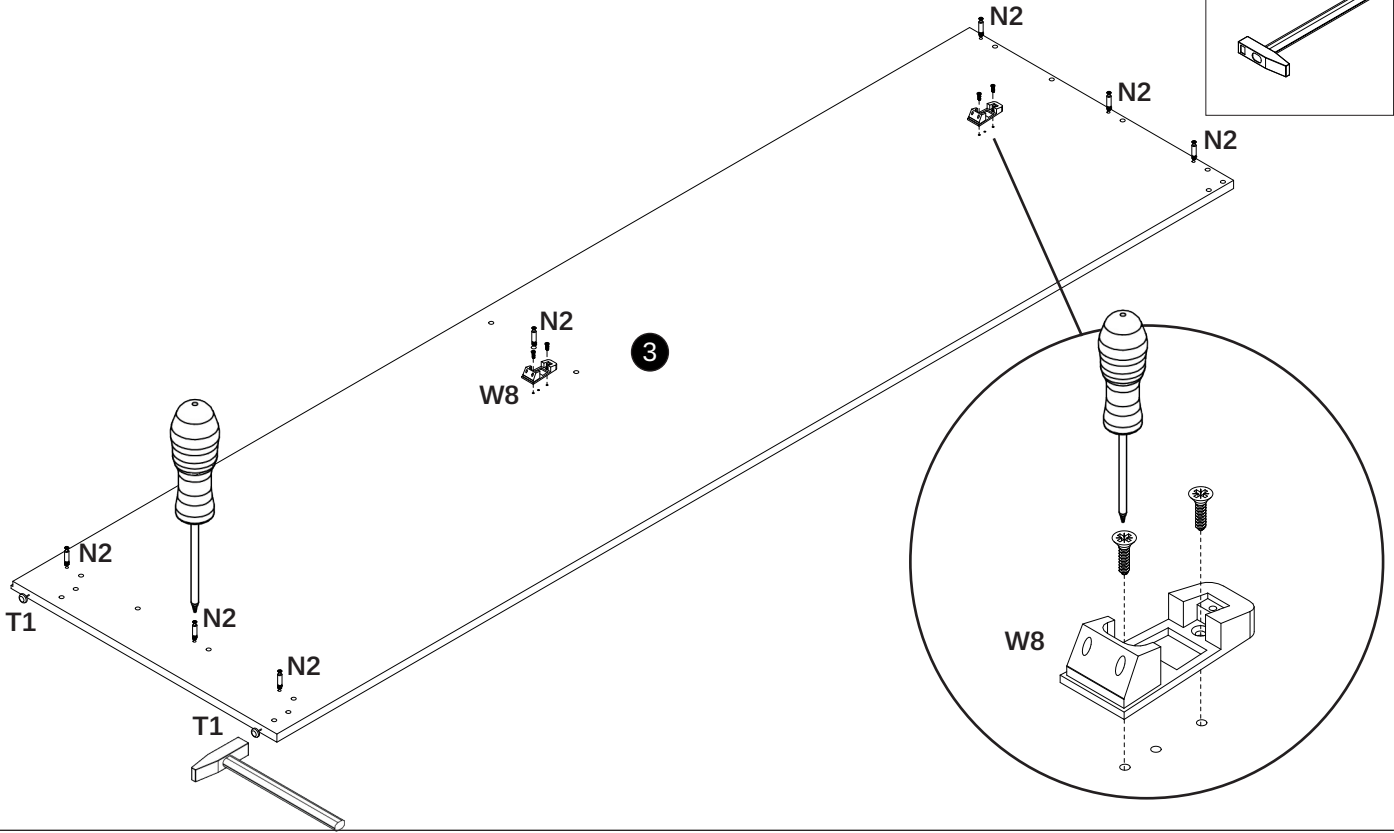

<b>2</b>	N2  7x	T1  2x	W8  2x	+  PH1	+  PZ2
					



ver 3

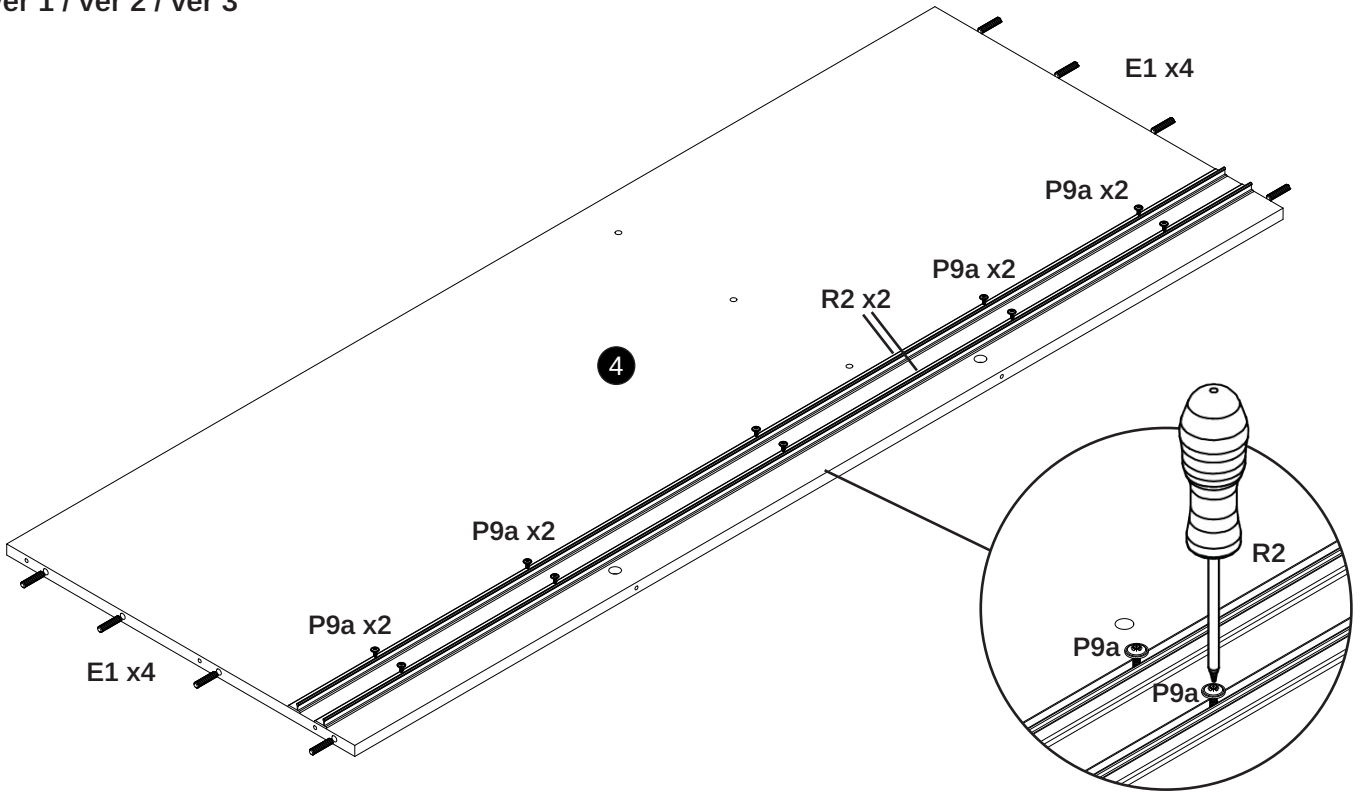

<b>3</b>	E1  8x	R2  2x	P9a  10x	+  PH1
----------	-------------------------------------------------------------------------------------------	-------------------------------------------------------------------------------------------	---------------------------------------------------------------------------------------------	---------------------------------------------------------------------------------------------

ver 1 / ver 2 / ver 3

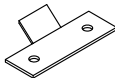

<b>3</b>	<b>E1</b>  8x	<b>R2</b>  2x	<b>P9a</b>  10x	<b>B7b</b>  4x
----------	------------------------------------------------------------------------------------------------------	------------------------------------------------------------------------------------------------------	---------------------------------------------------------------------------------------------------------	---------------------------------------------------------------------------------------------------------

ver 3

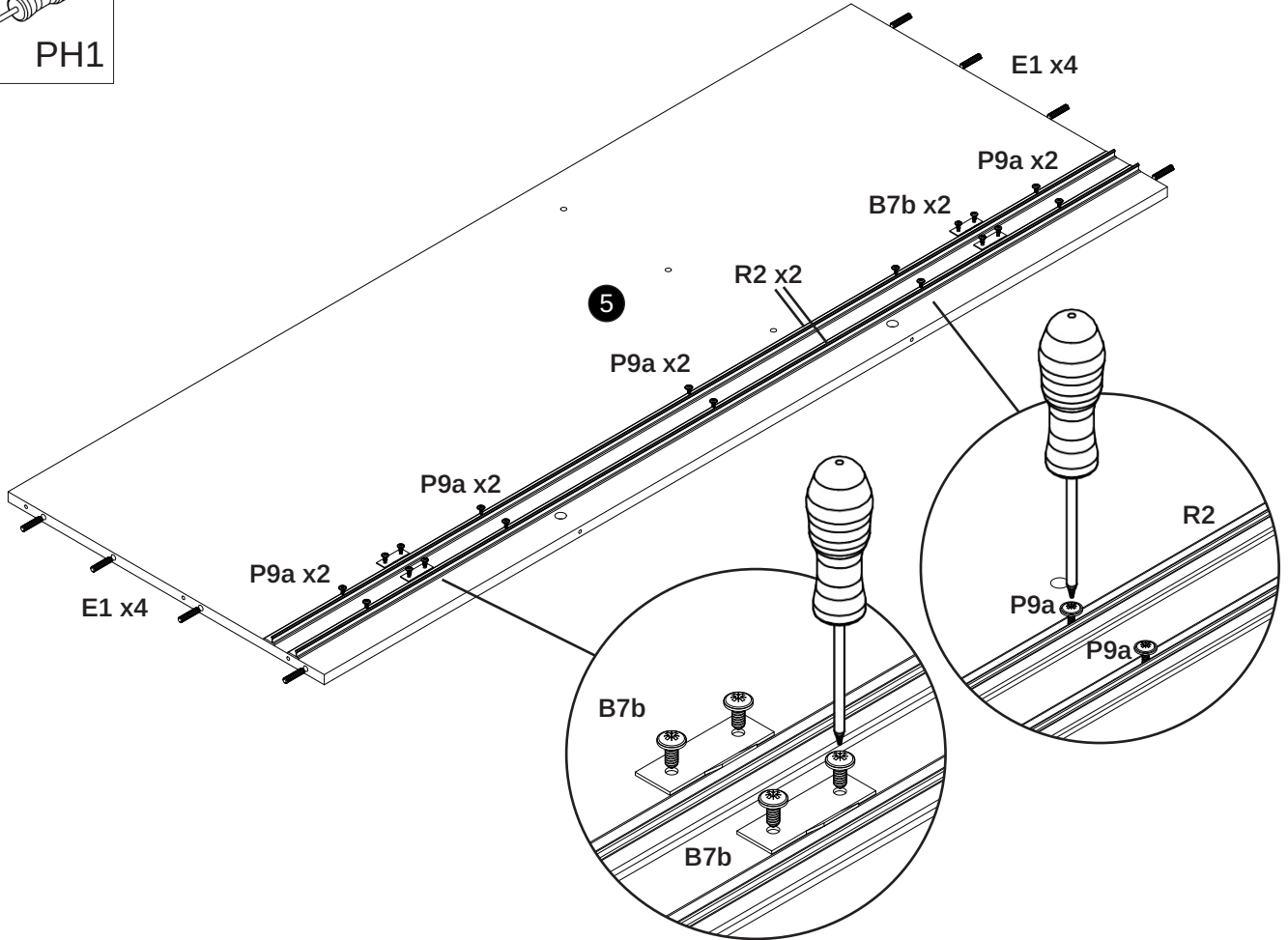
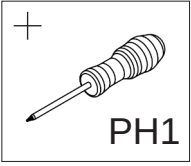

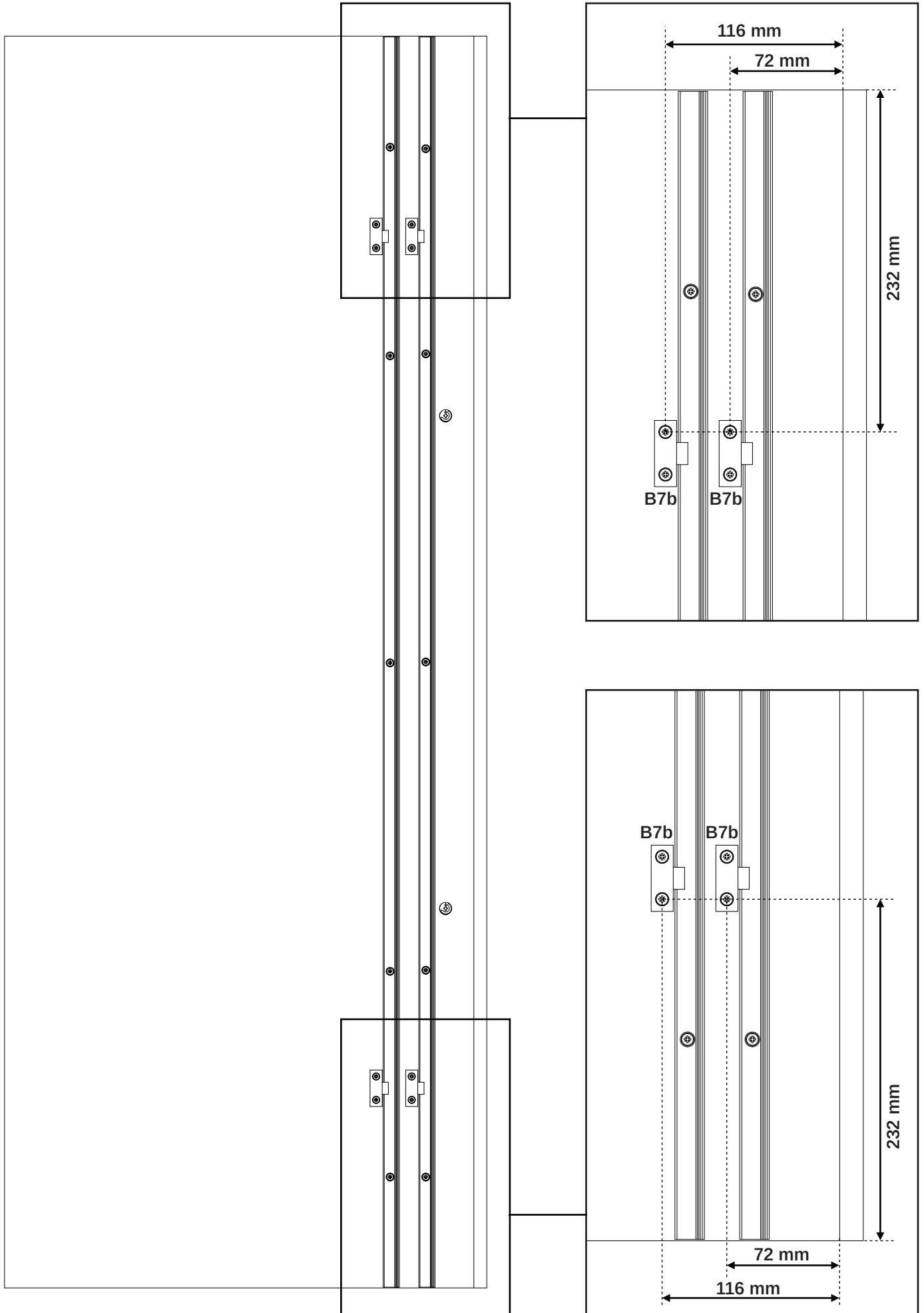

<b>4</b>	E1 	R7 	S1c 	+  PZ2
	8x	4x	4x	



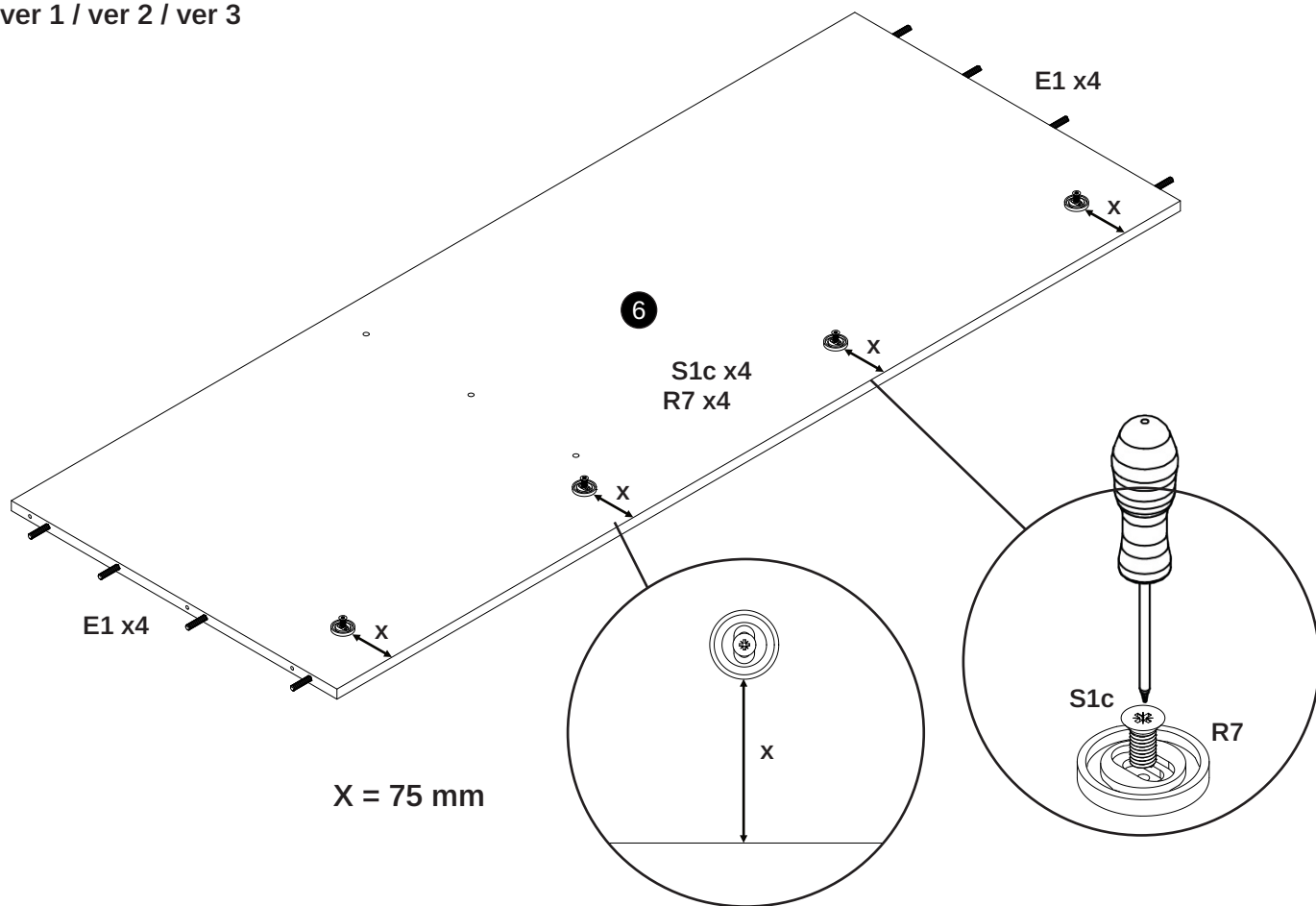



ver 1 / ver 2 / ver 3

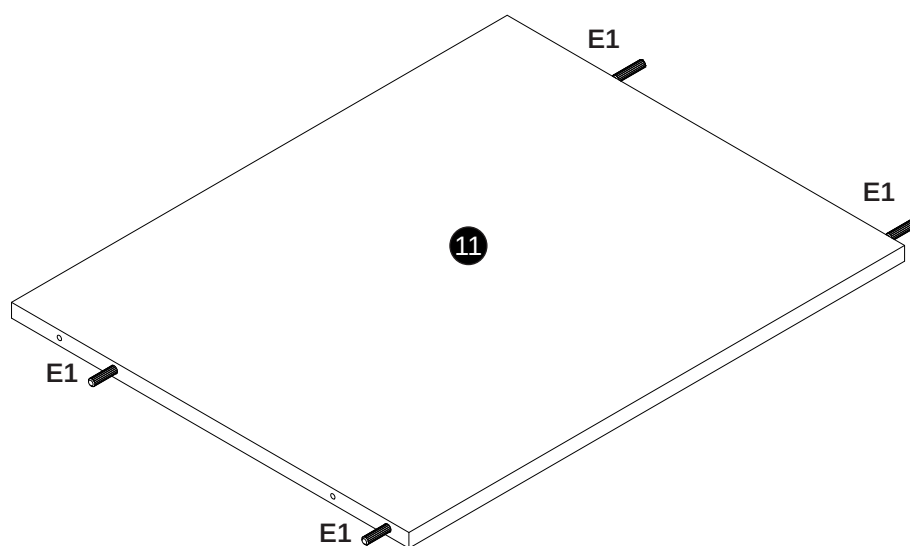





<b>5</b>	E1 
	4x

ver 1 / ver 2 / ver 3

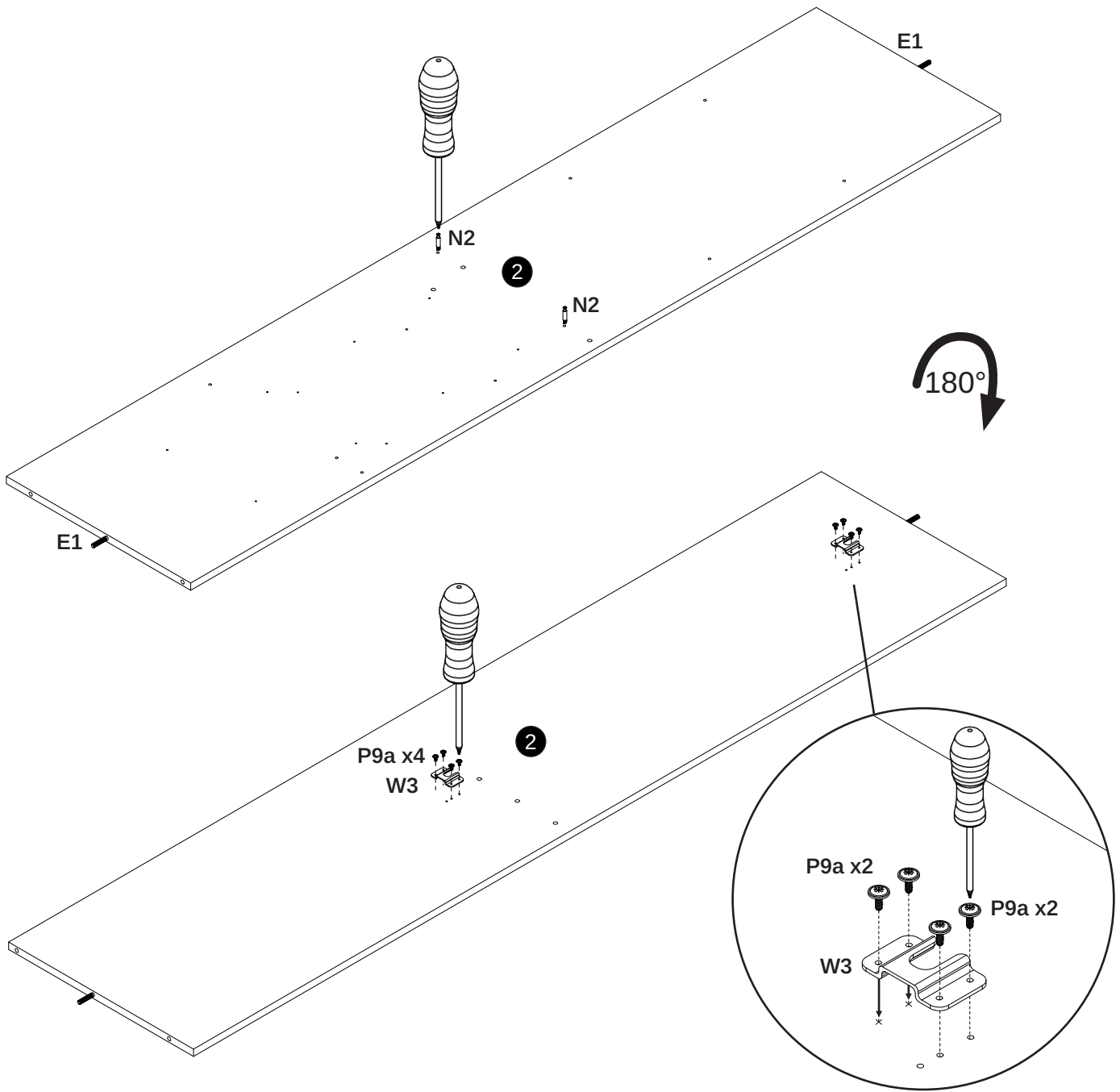

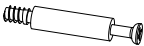
<b>6</b> ver 1 i ver 2	N2  2x	P9a  8x	W3  2x	+  PH1	+  PZ2
	E1  2x				



<h1>6</h1>	<p>N2 </p> <p>2x</p>	<p>E1 </p> <p>2x</p>	<p>W8 </p> <p>2x</p>	<p>+ </p> <p>PH1</p>	<p>+ </p> <p>PZ2</p>
------------	-------------------------------------------------------------------------------------------------------	-------------------------------------------------------------------------------------------------------	-------------------------------------------------------------------------------------------------------	---------------------------------------------------------------------------------------------------------	---------------------------------------------------------------------------------------------------------

ver 3

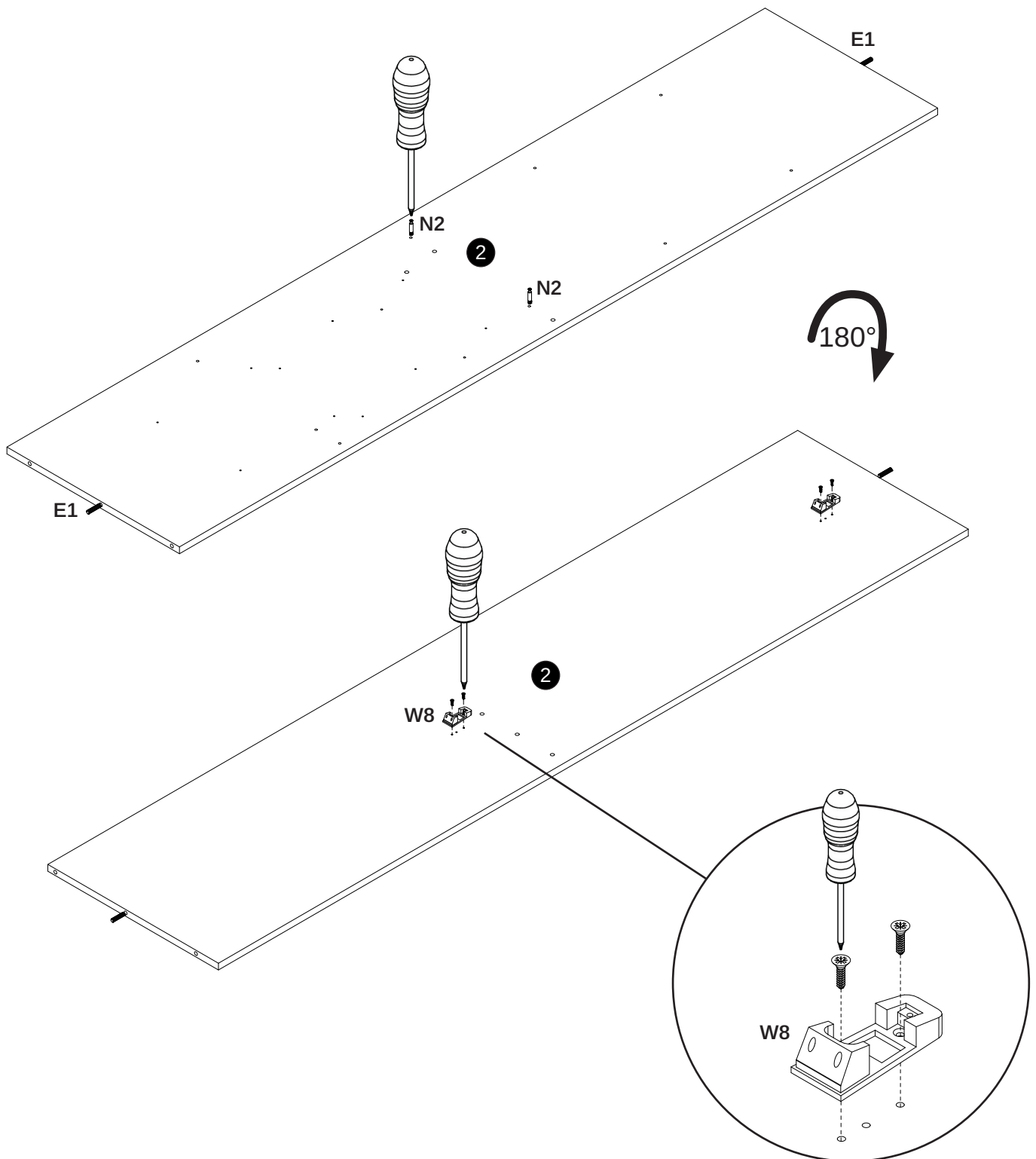

<b>7</b>	E1	N2
	4x	2x

+
PZ2

ver 1 / ver 2 / ver 3

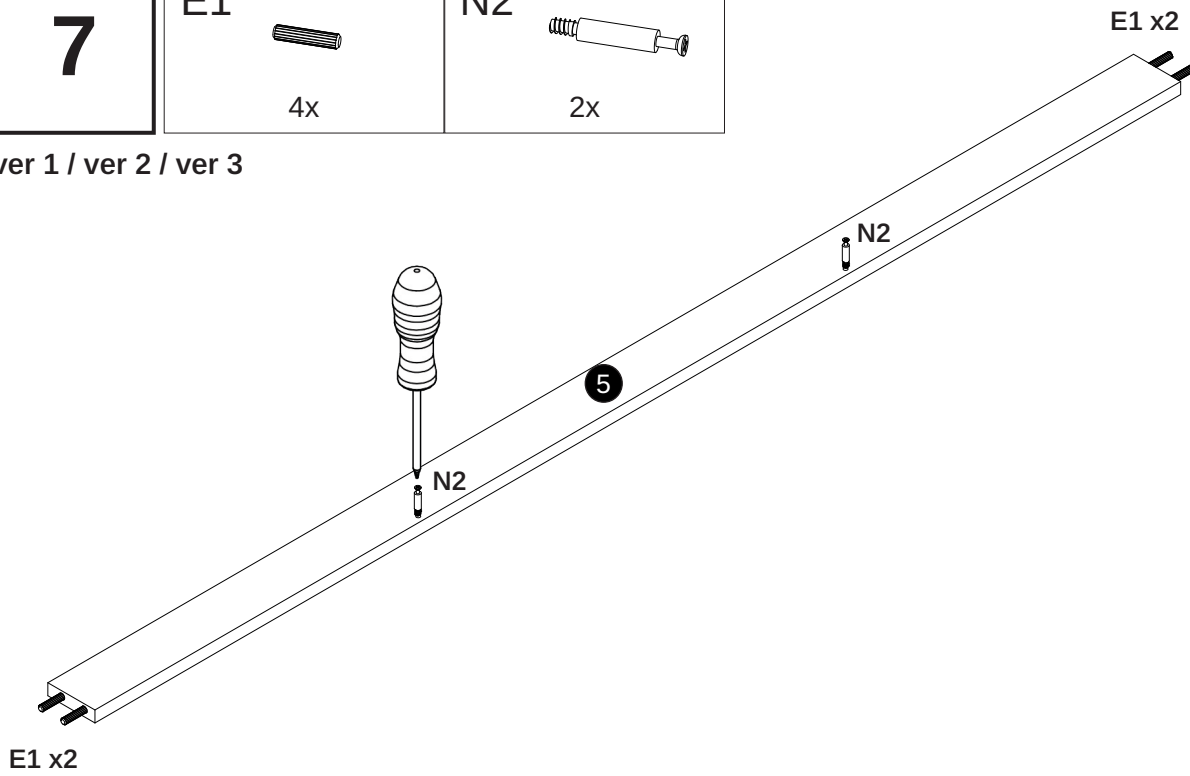

<b>8</b>	E1	T1
	6x	3x

ver 1 / ver 2 / ver 3

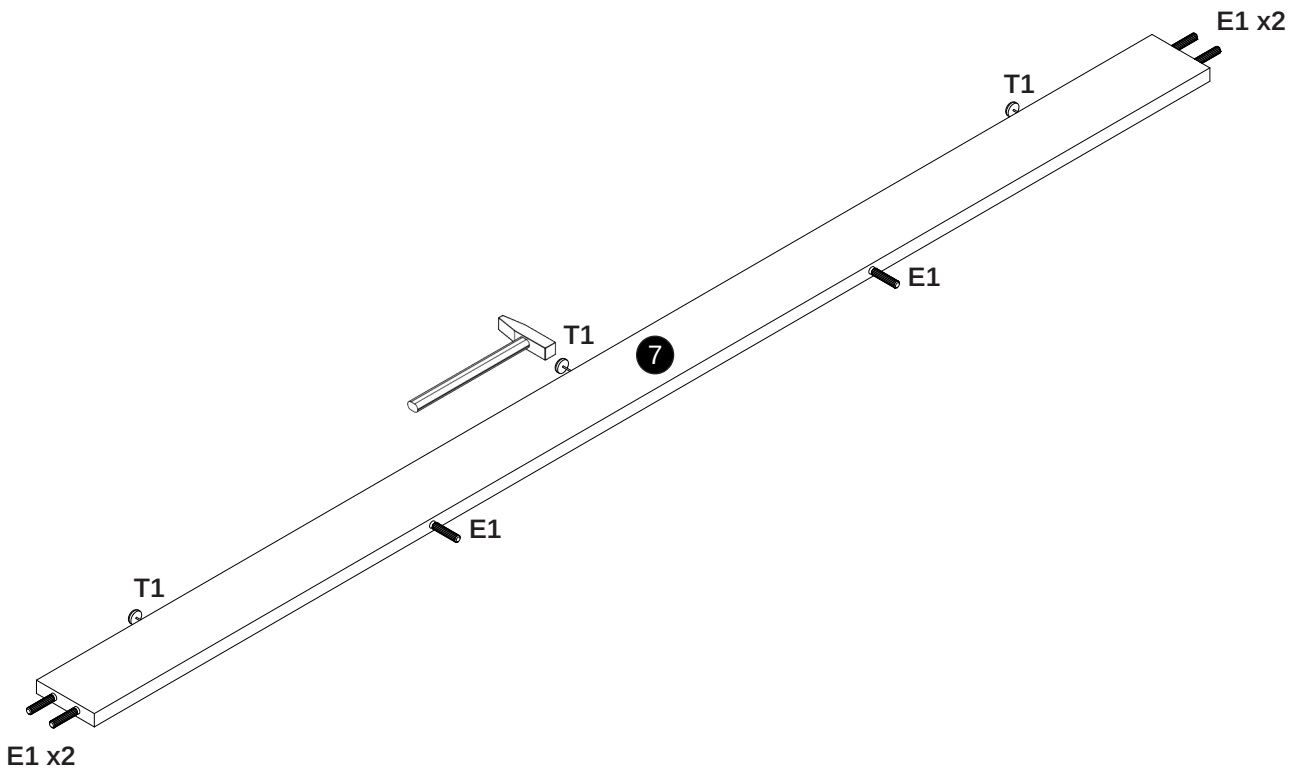

<b>9</b>	<b>E1</b>  4x
----------	------------------------------------------------------------------------------------------------------

ver 1 / ver 2 / ver 3

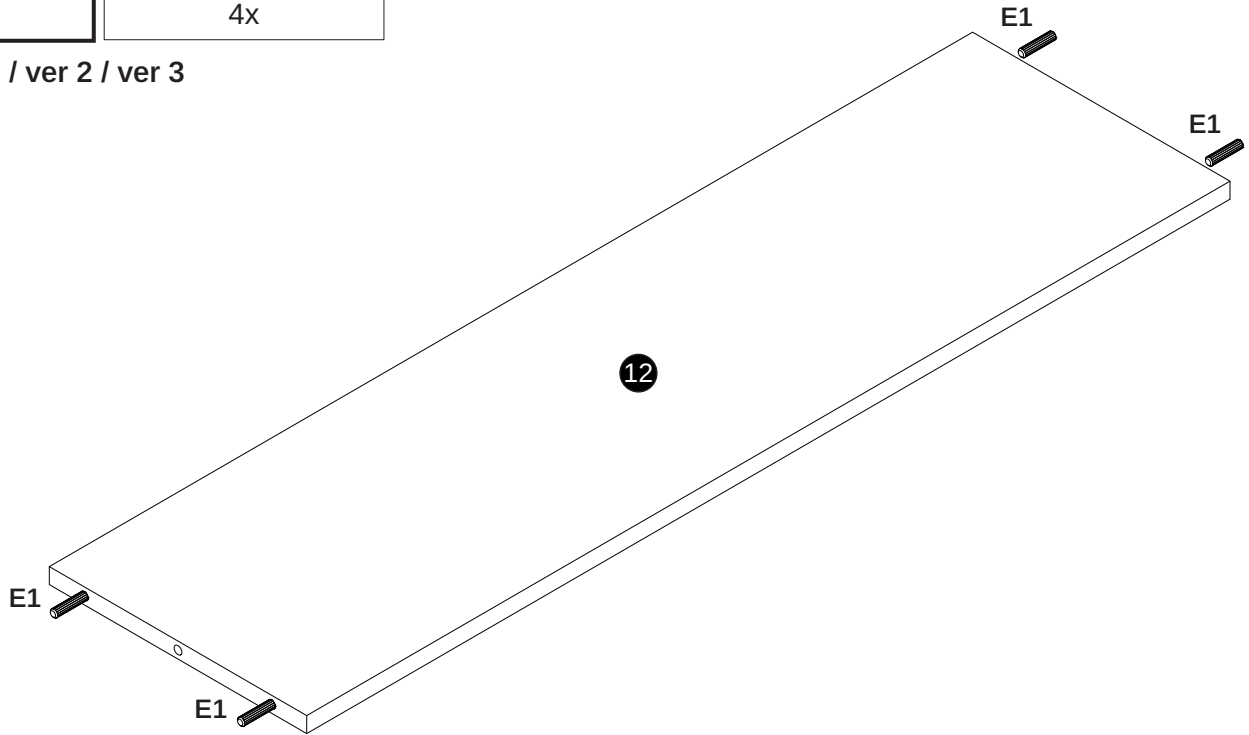

<b>10</b>	<b>M3</b>  2x
-----------	--------------------------------------------------------------------------------------------------------

ver 1 / ver 2 / ver 3

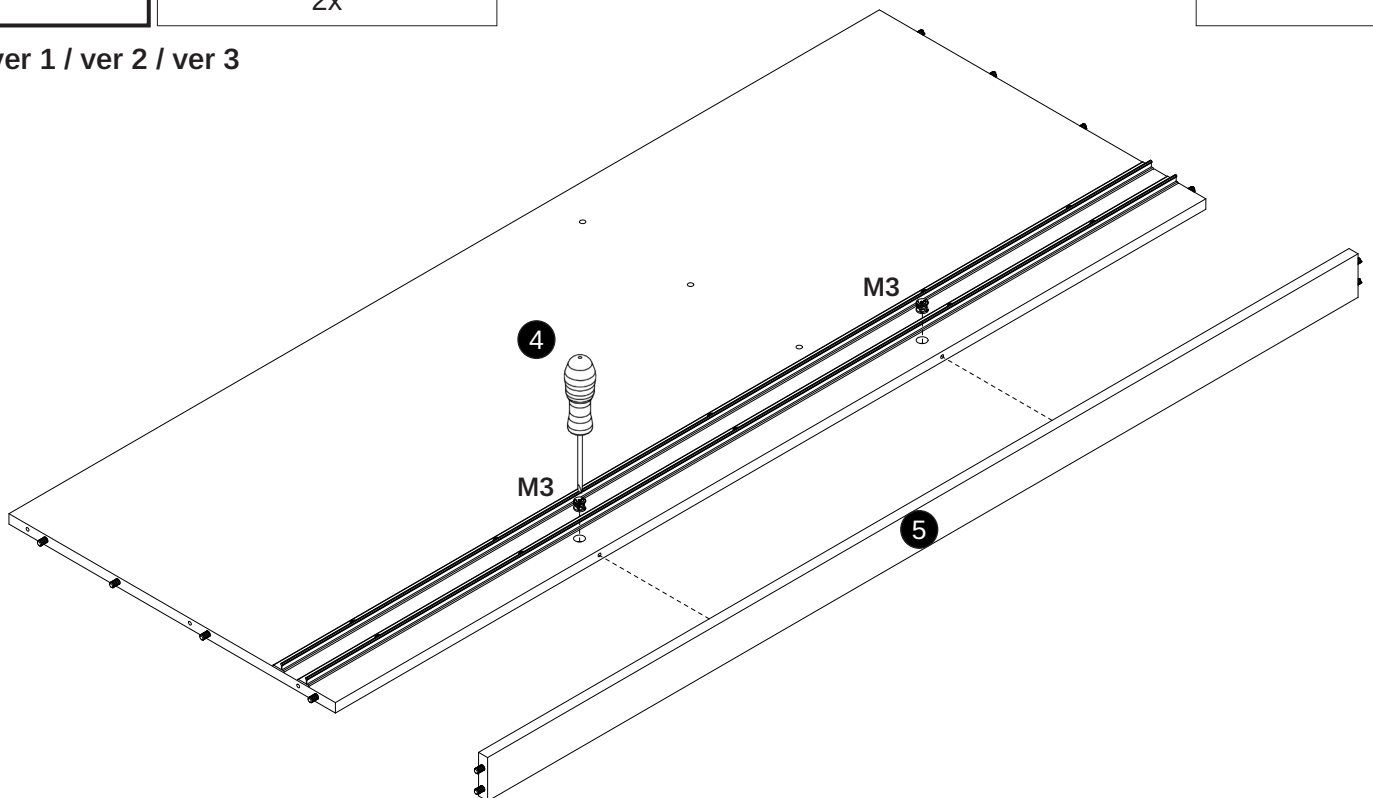
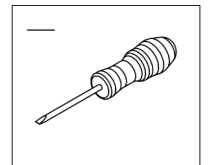

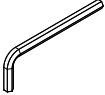
<b>11</b>	F1		K2	
		2x		1x

ver 1 / ver 2 / ver 3

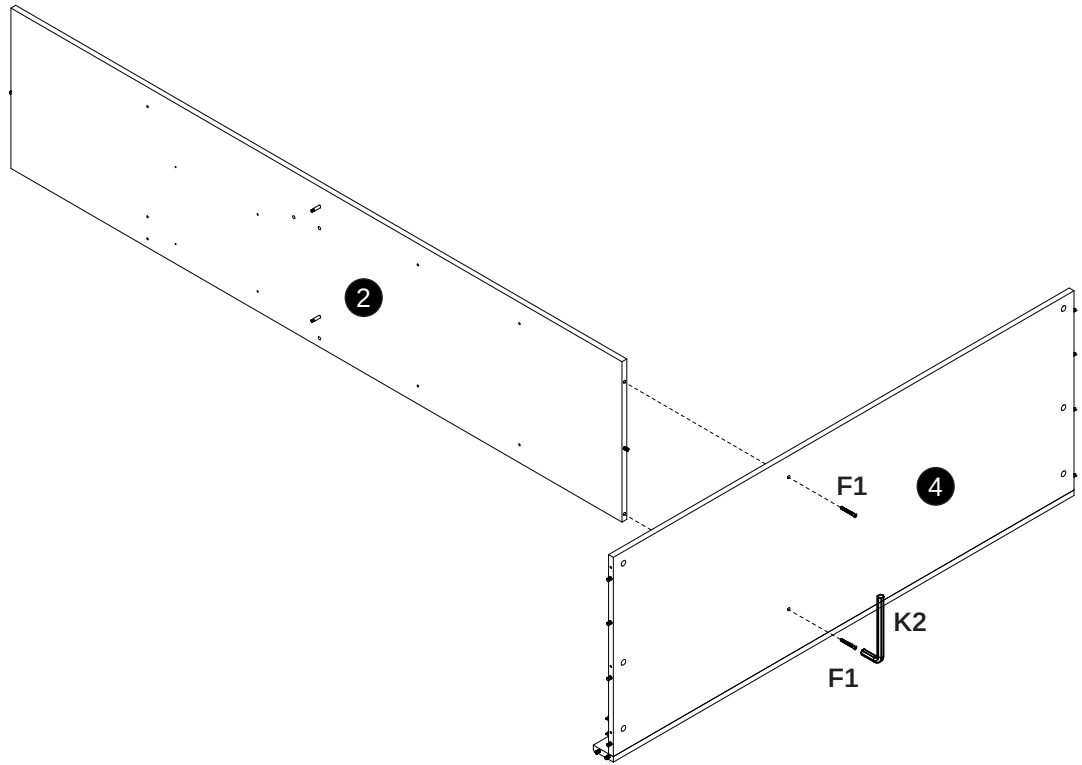

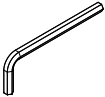
<b>12</b>	F1		K2	
		1x		1x

ver 1 / ver 2 / ver 3

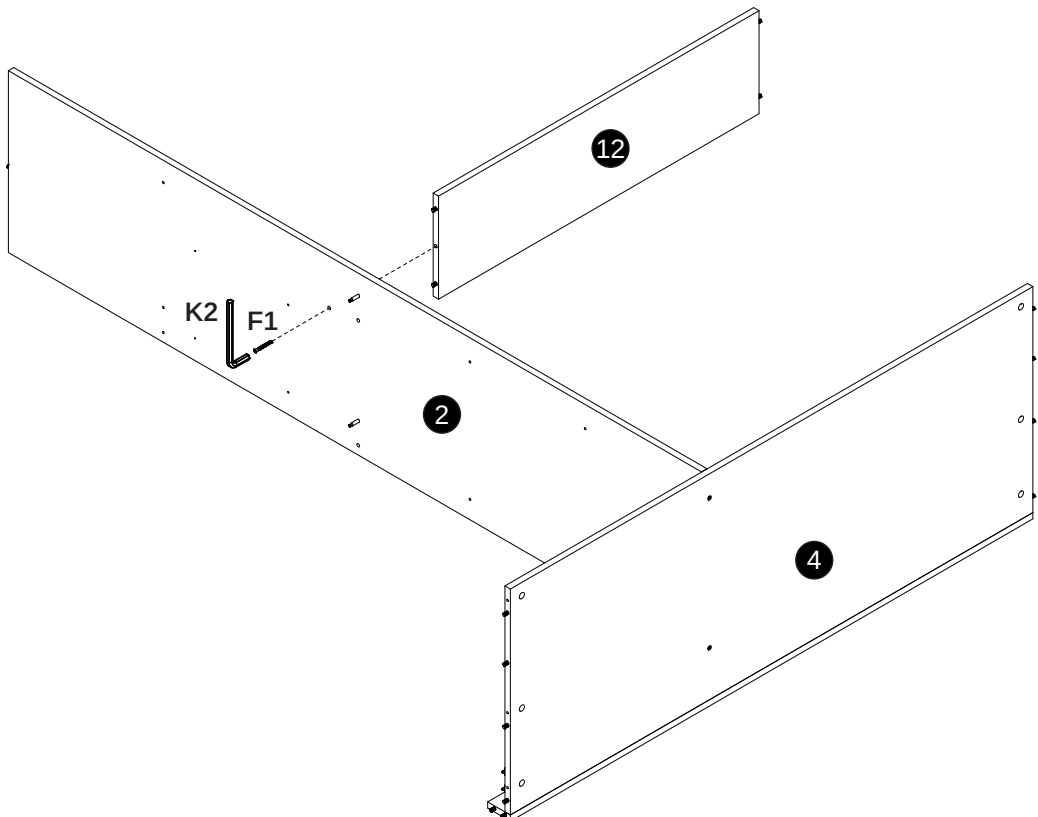

<b>13</b>	F1		K2	
		2x		1x

ver 1 / ver 2 / ver 3

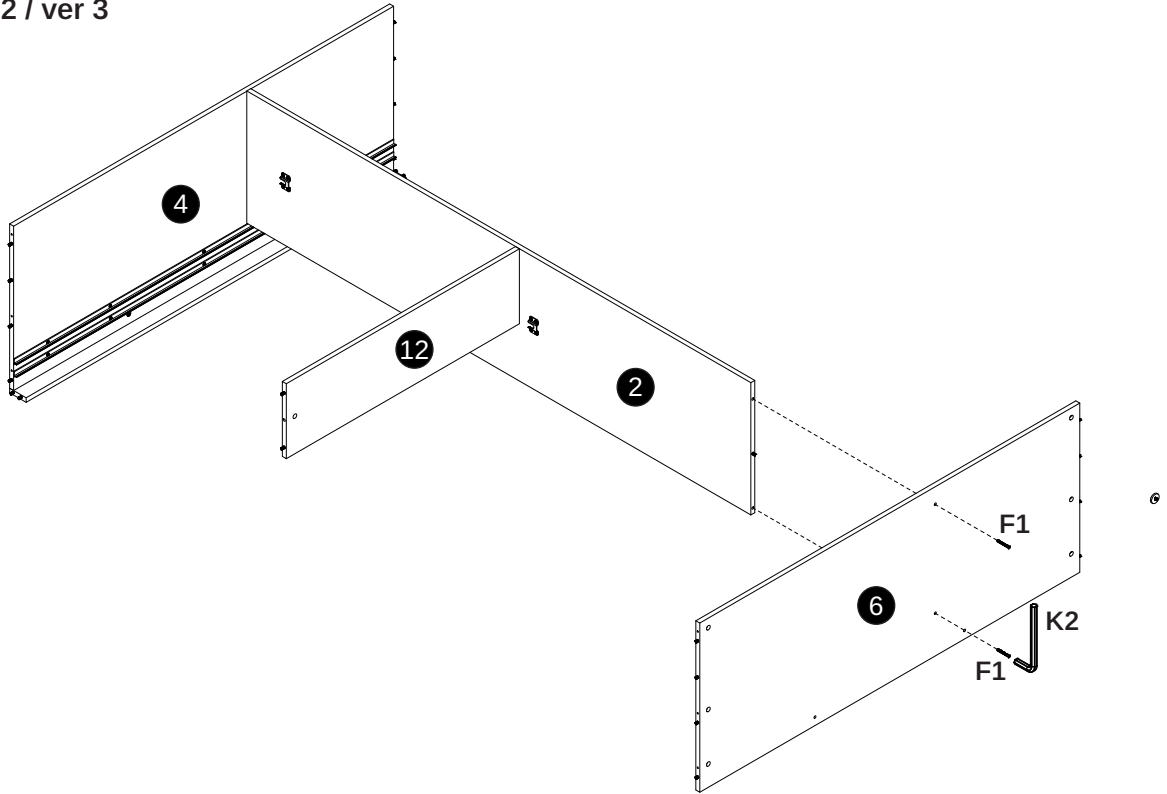

<b>14</b>	M3	
		2x

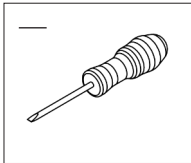

ver 1 / ver 2 / ver 3

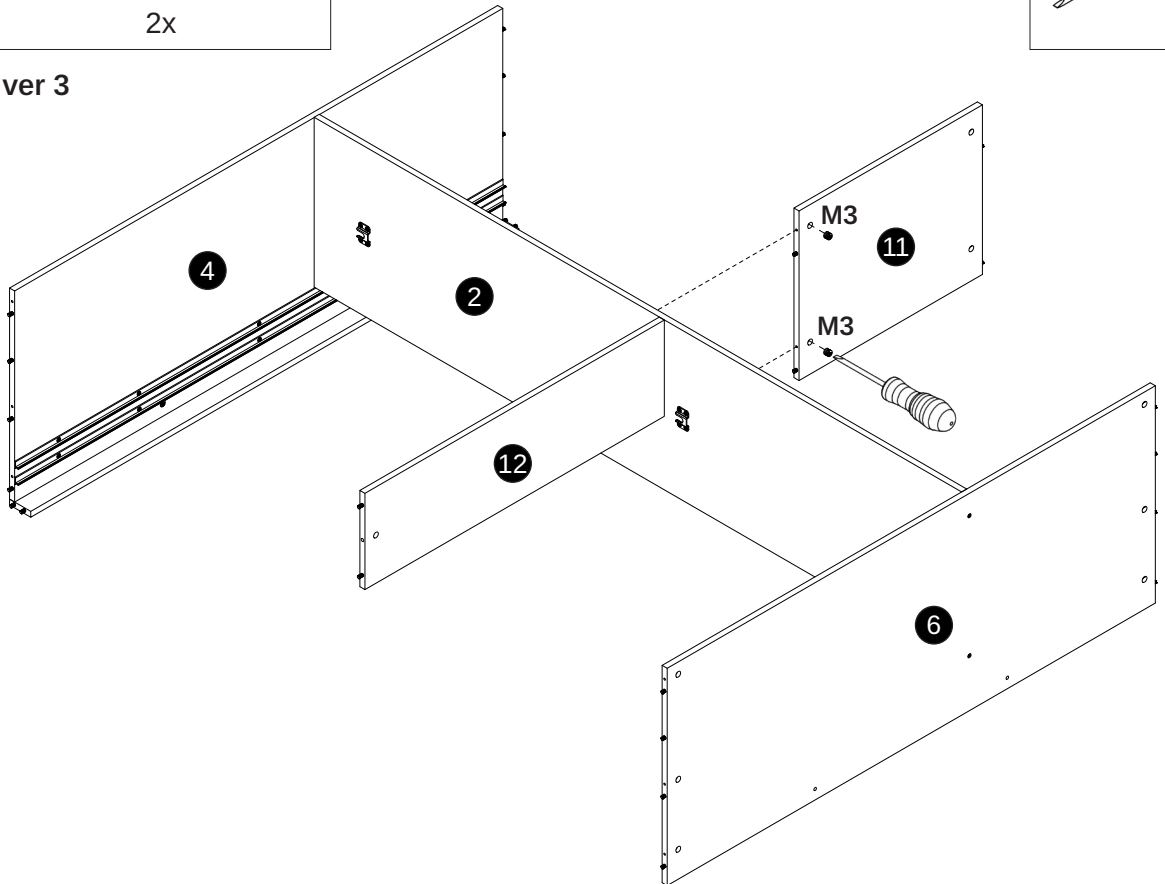

# 15

ver 1 / ver 2 / ver 3

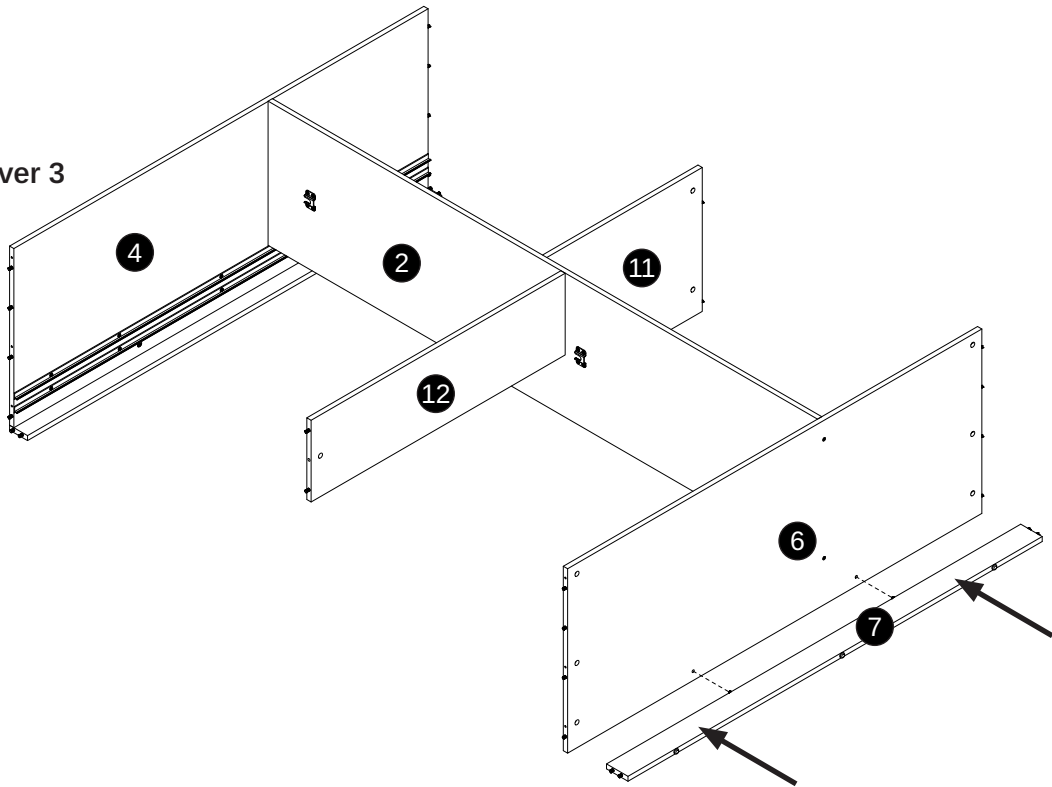

# 16

M3



7x

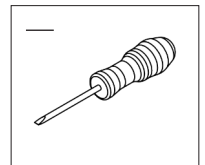

ver 1 / ver 2 / ver 3

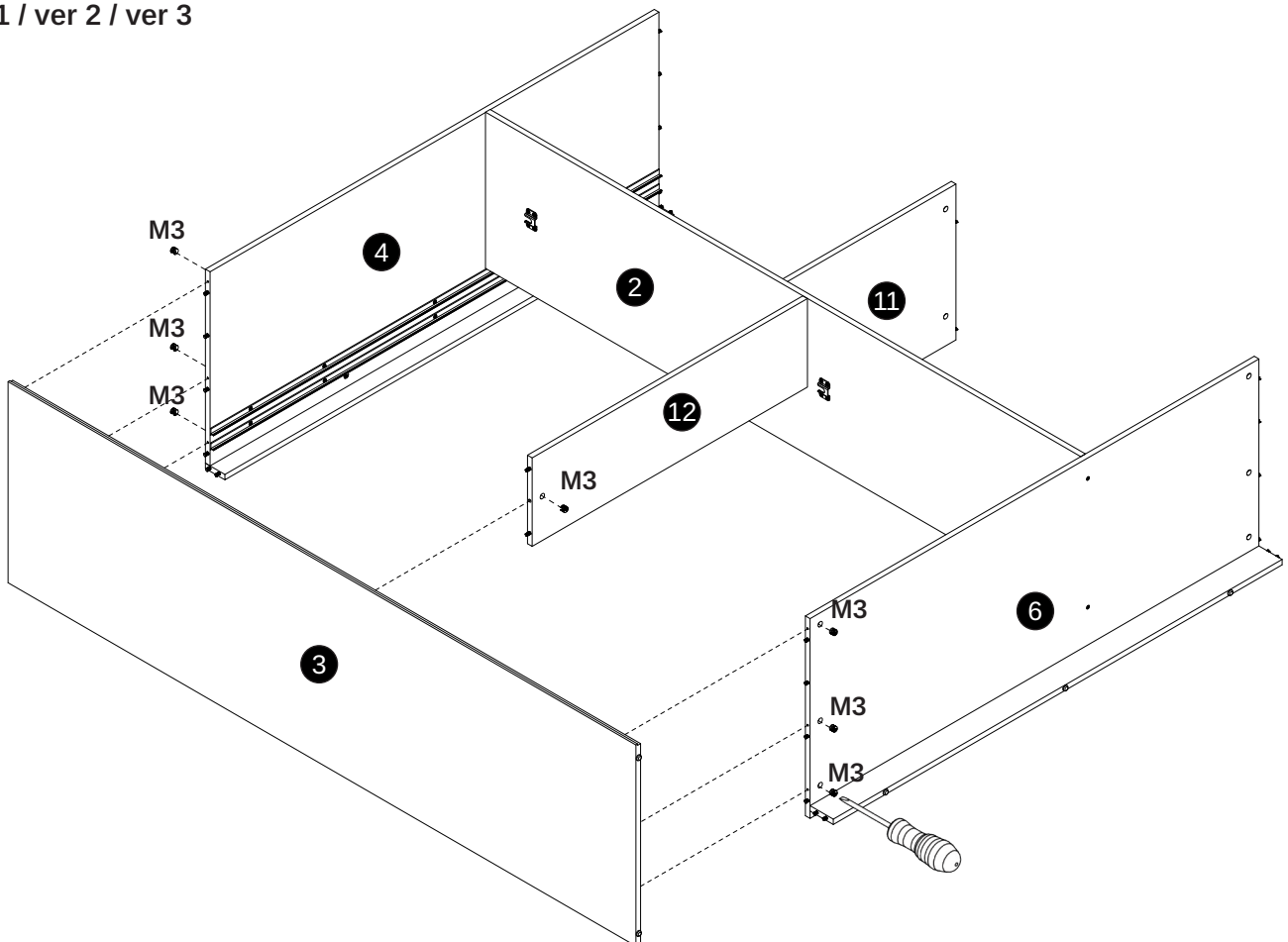

**17** M3 8x

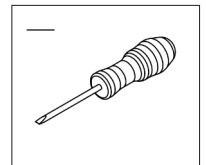
ver 1 / ver 2 / ver 3

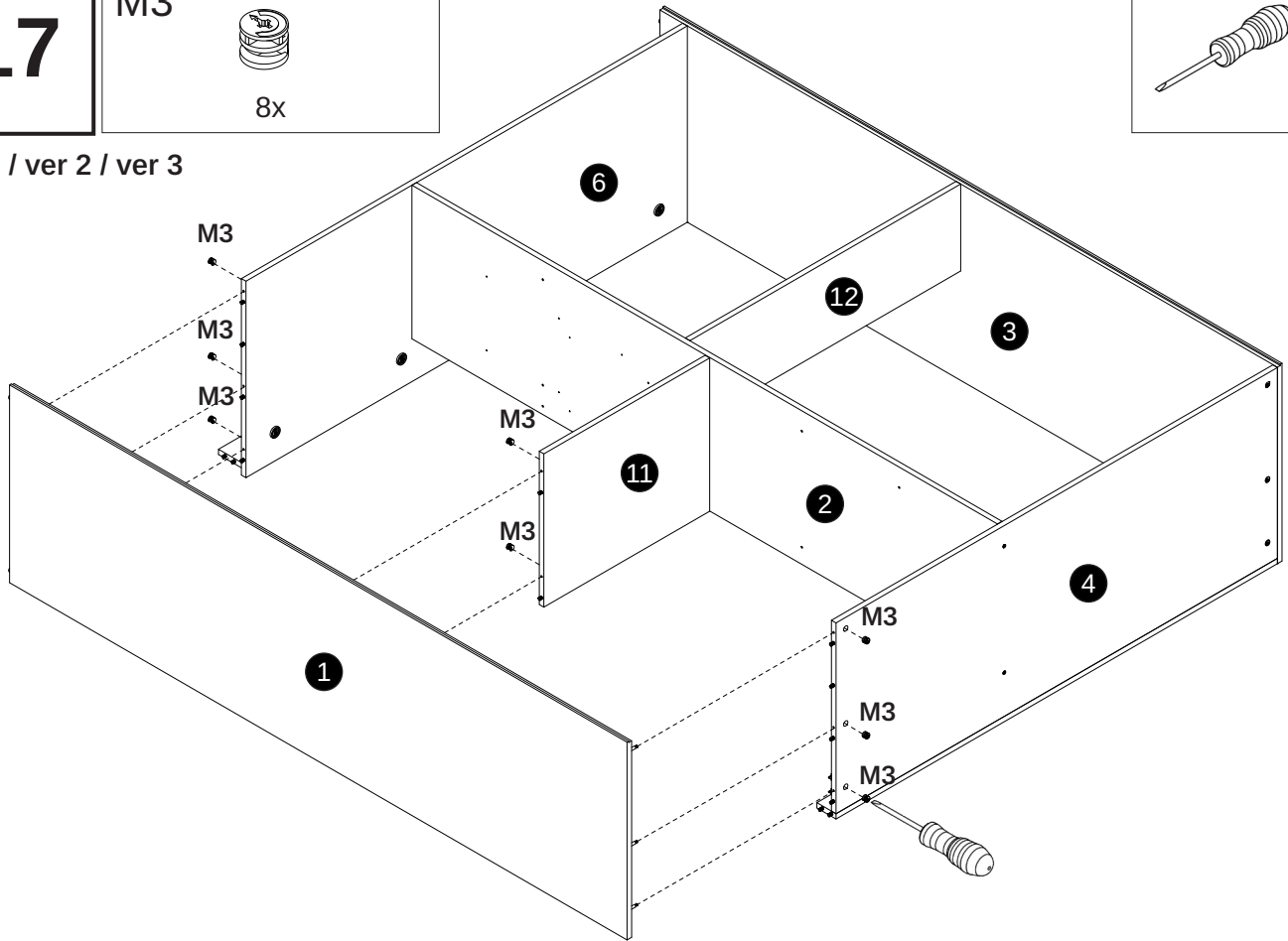

**18** H1 2x

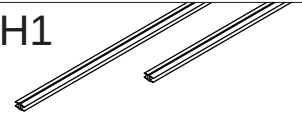

ver 1 / ver 2 / ver 3

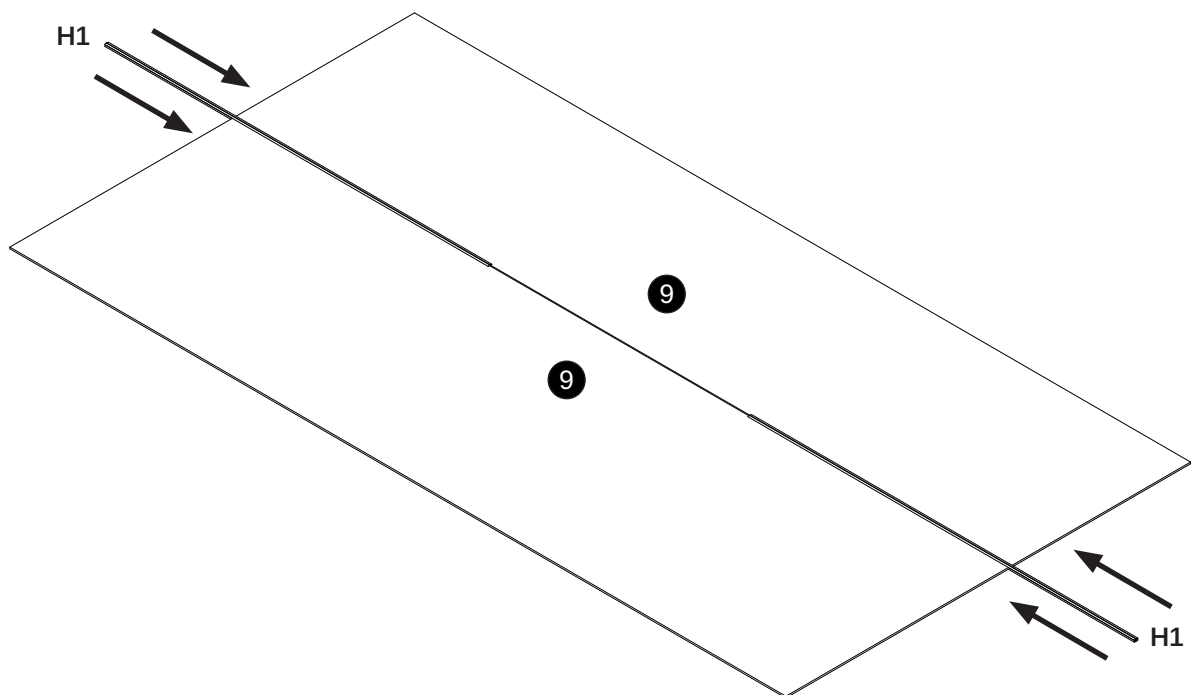

# 19

L1



6x

S0b



50x

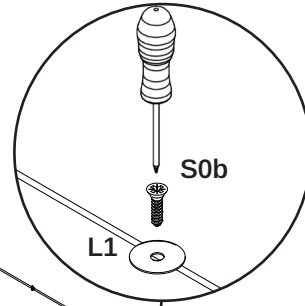

+



PH1



ver 1 / ver 2 / ver 3

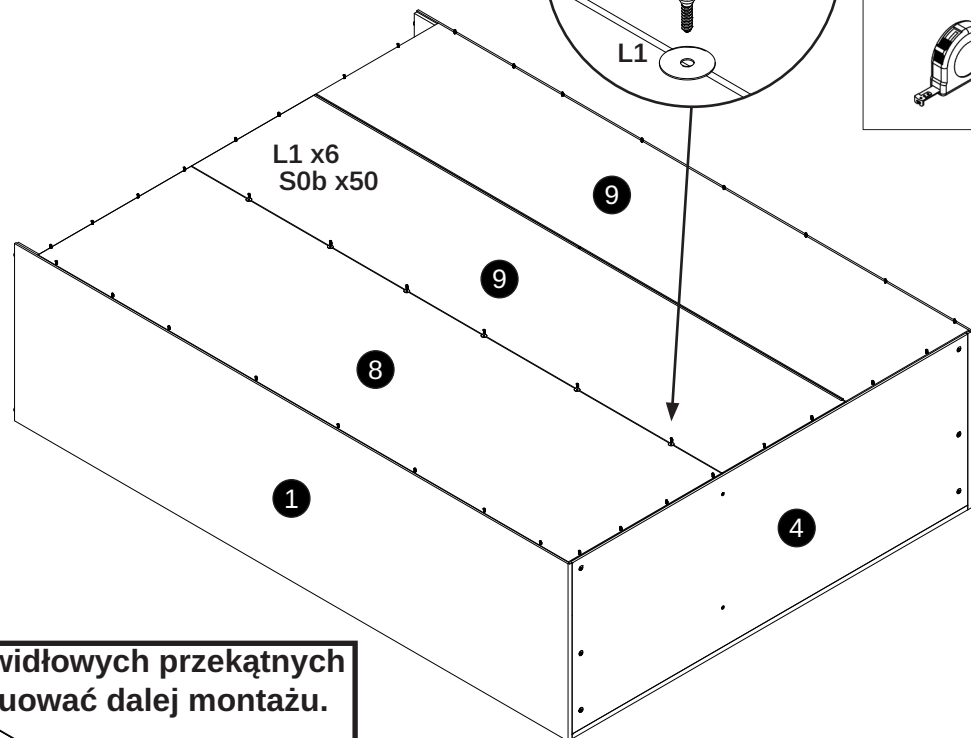

**Bez sprawdzenia prawidłowych przekątnych  
NIE MOŻESZ kontynuować dalej montażu.**

X=Y !

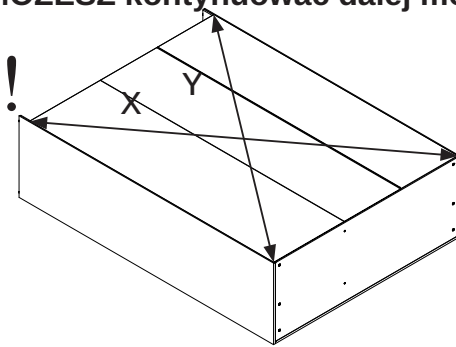

# 20



D5



8x

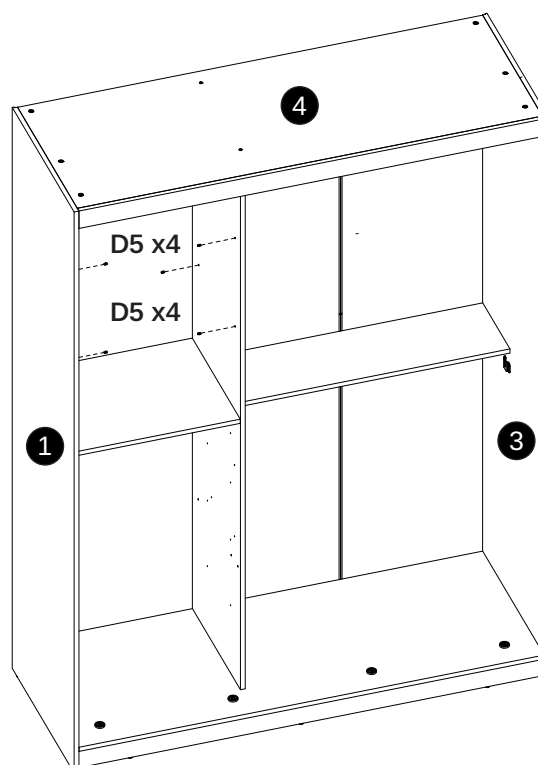

ver 1 / ver 2 / ver 3

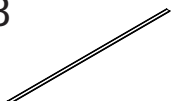

<b>21</b>	<b>W4</b>  2x	<b>F10</b>  x5	<b>M2</b>  x11	<b>R8</b>  1x
-----------	-----------------------------------------------------------------------------------------------------	-------------------------------------------------------------------------------------------------------	--------------------------------------------------------------------------------------------------------	--------------------------------------------------------------------------------------------------------

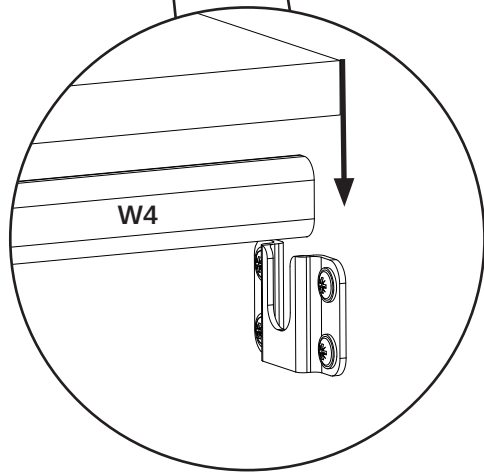
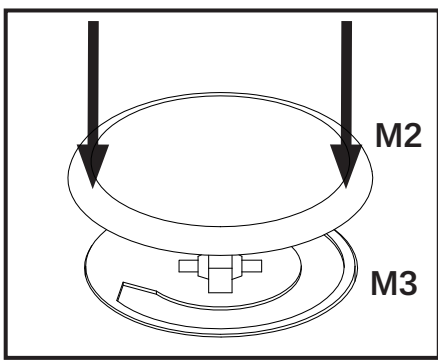
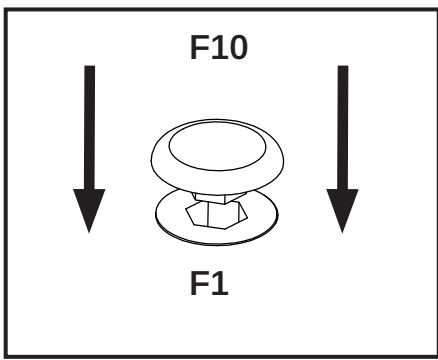
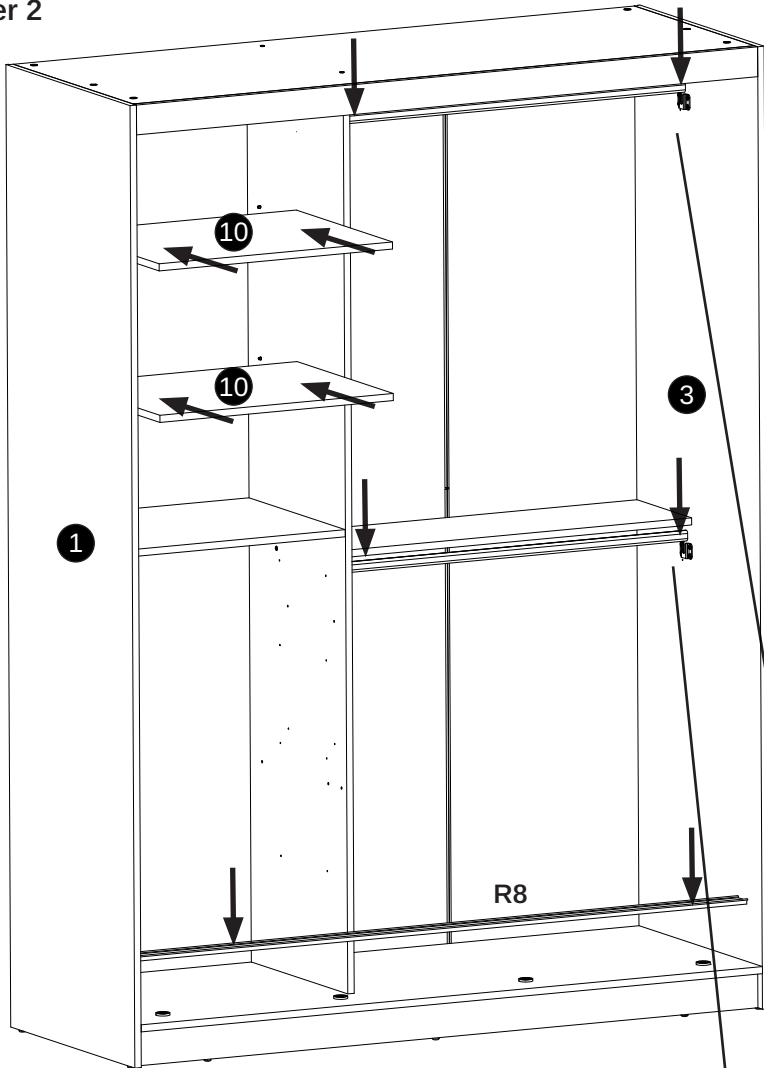



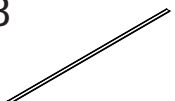

ver 1 / ver 2

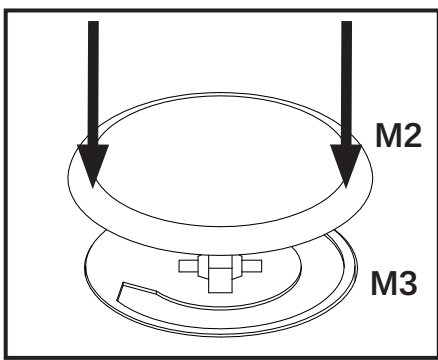
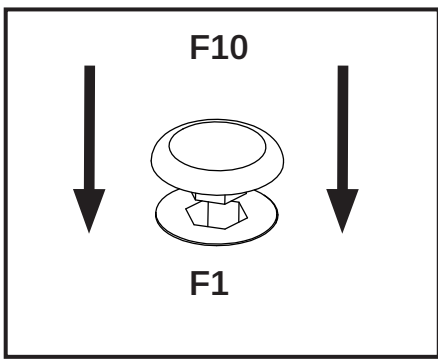
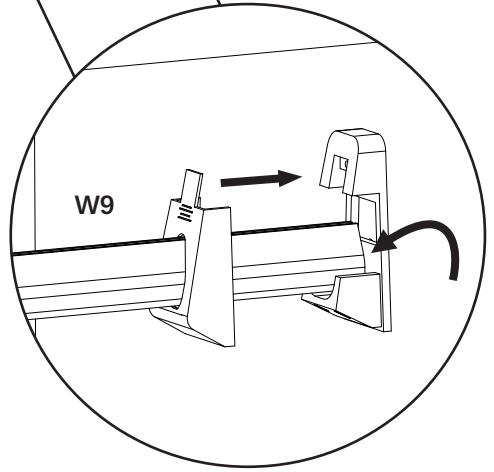

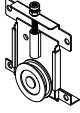
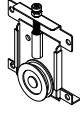
<b>21</b>	W9	F10	M2	R8
	 2x	 x5	 x11	 1x

ver 3



<b>22</b>	R5d  2x	R5g  2x	P9c  8x	+  PZ2	+  PH1
	ver 1 / ver 2 / ver 3		P9a  8x	S1c  2x	

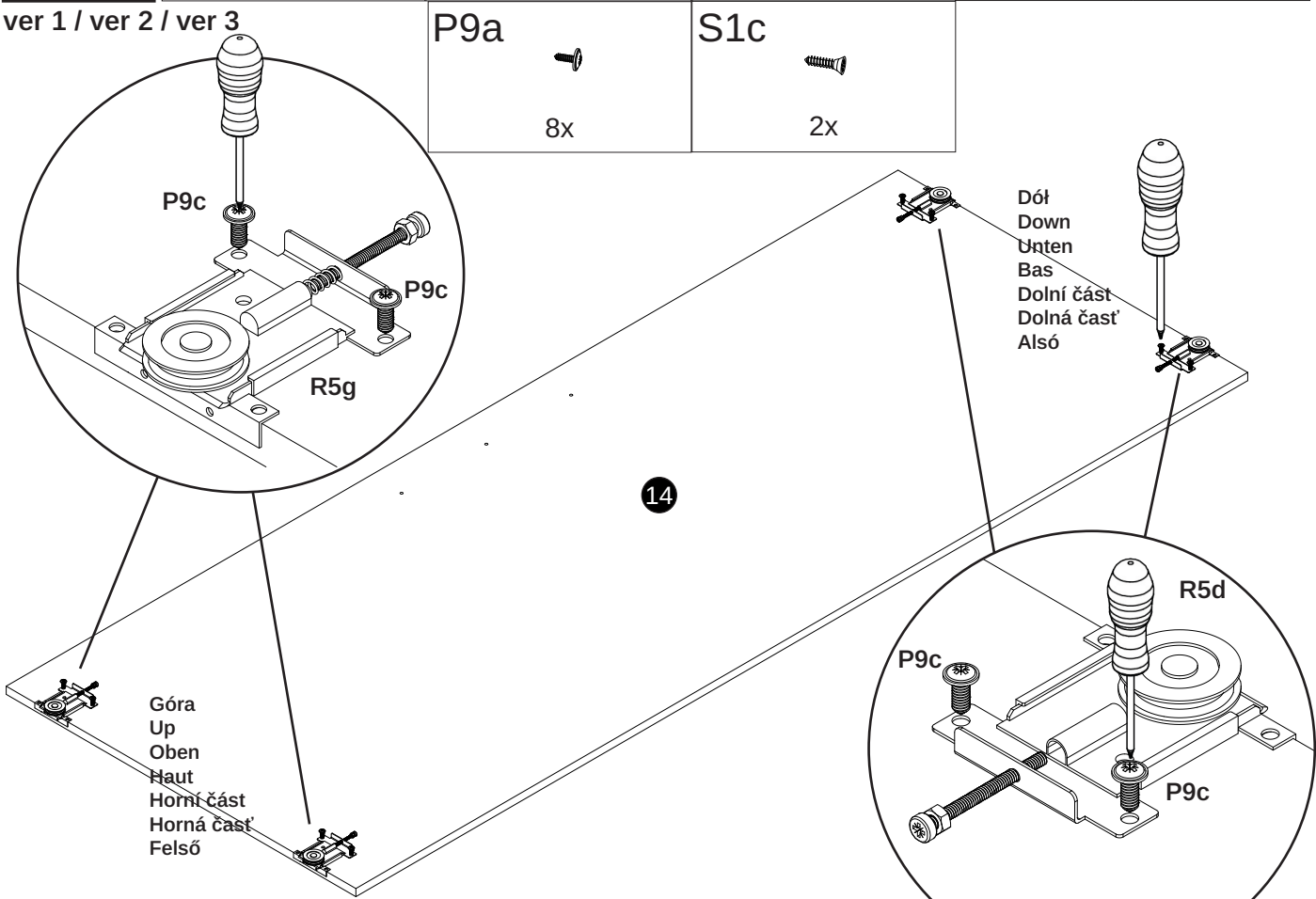

**PATRZ STRONA 6**  
**SEE PAGE 6**  
**SIEHE SEITE 6**  
**VOIR PAGE 6**  
**VIZ STRANA 6**  
**VIĎ STRANA 6**  
**NÉZZE MEG A 6. OLDALT**

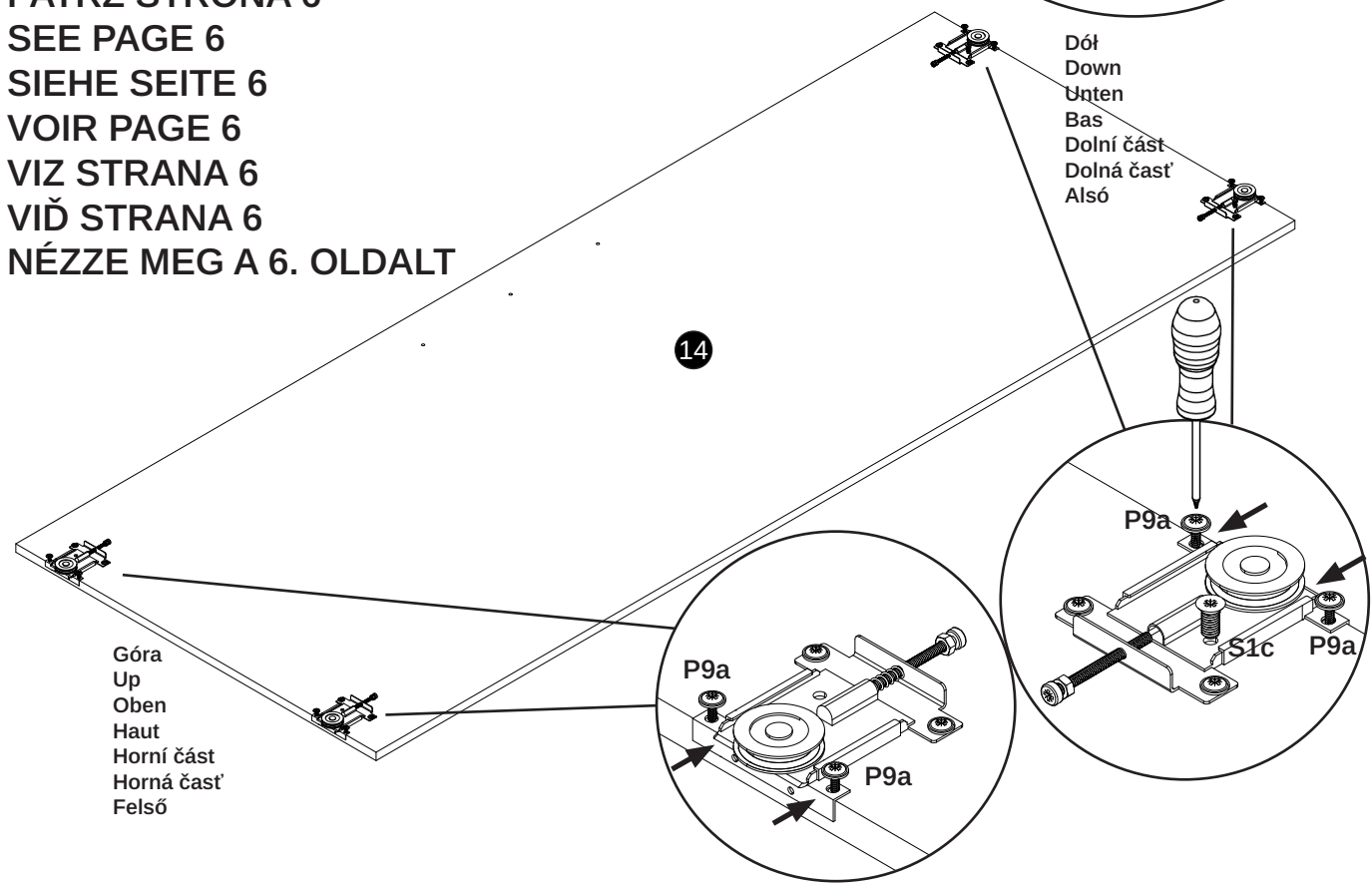





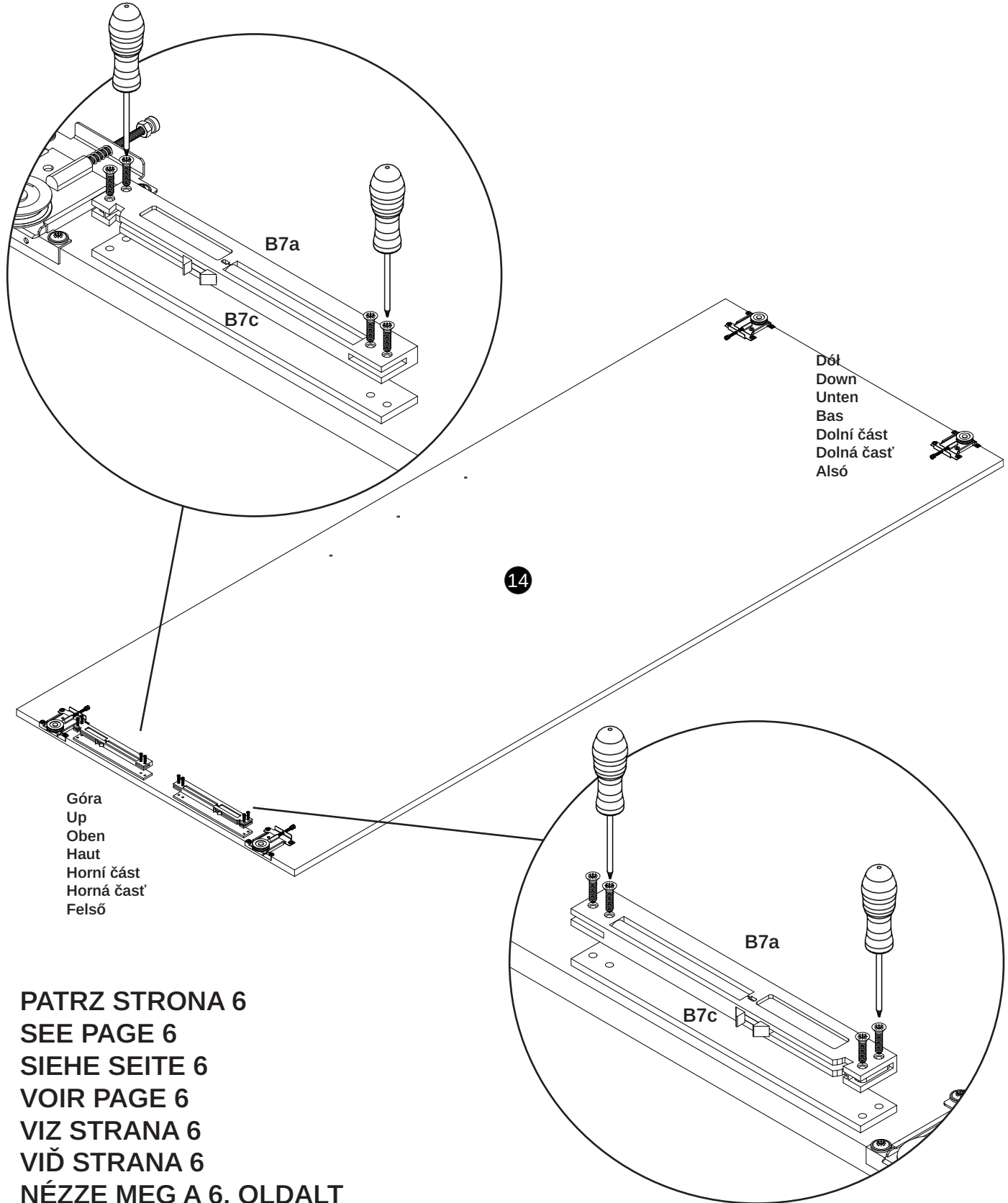
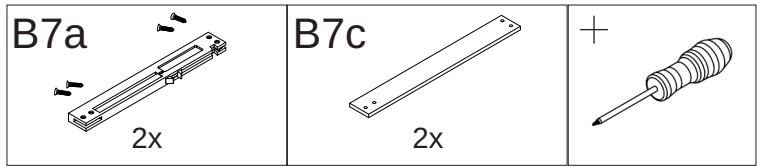

**22**

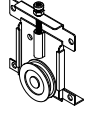
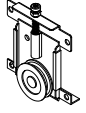
ver 3



PATRZ STRONA 6  
SEE PAGE 6  
SIEHE SEITE 6  
VOIR PAGE 6  
VIZ STRANA 6  
VIĎ STRANA 6  
NÉZZE MEG A 6. OLDALT

<b>23</b>	R5d  4x	R5g  4x	P9c  8x	+	 PZ2	+	 PH1
	ver 1 / ver 2 / ver 3		P9a  8x	S1c  4x			

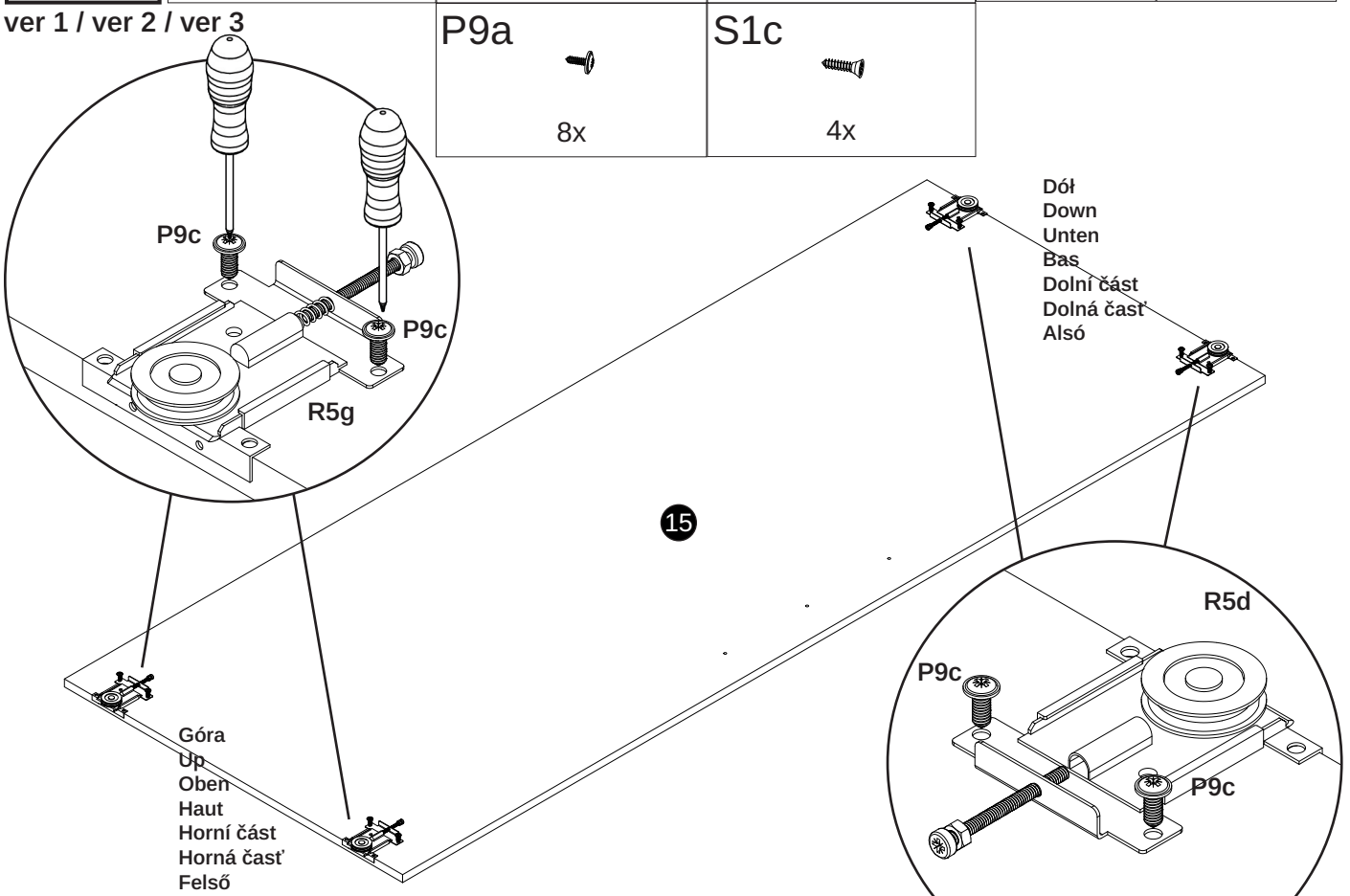

**PATRZ STRONA 6**  
**SEE PAGE 6**  
**SIEHE SEITE 6**  
**VOIR PAGE 6**  
**VIZ STRANA 6**  
**VIĎ STRANA 6**  
**NÉZZE MEG A 6. OLDALT**

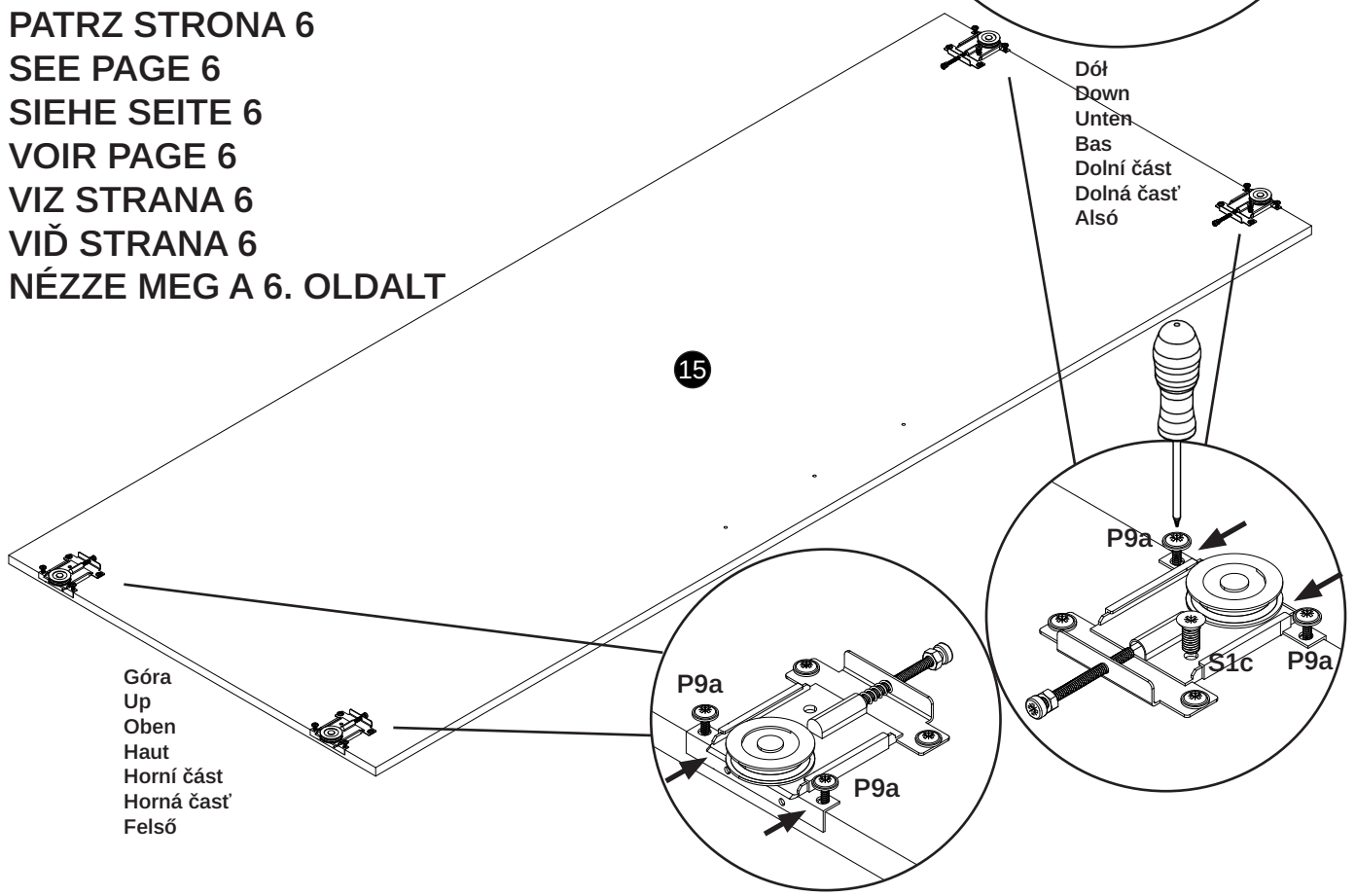

# 23

ver 3

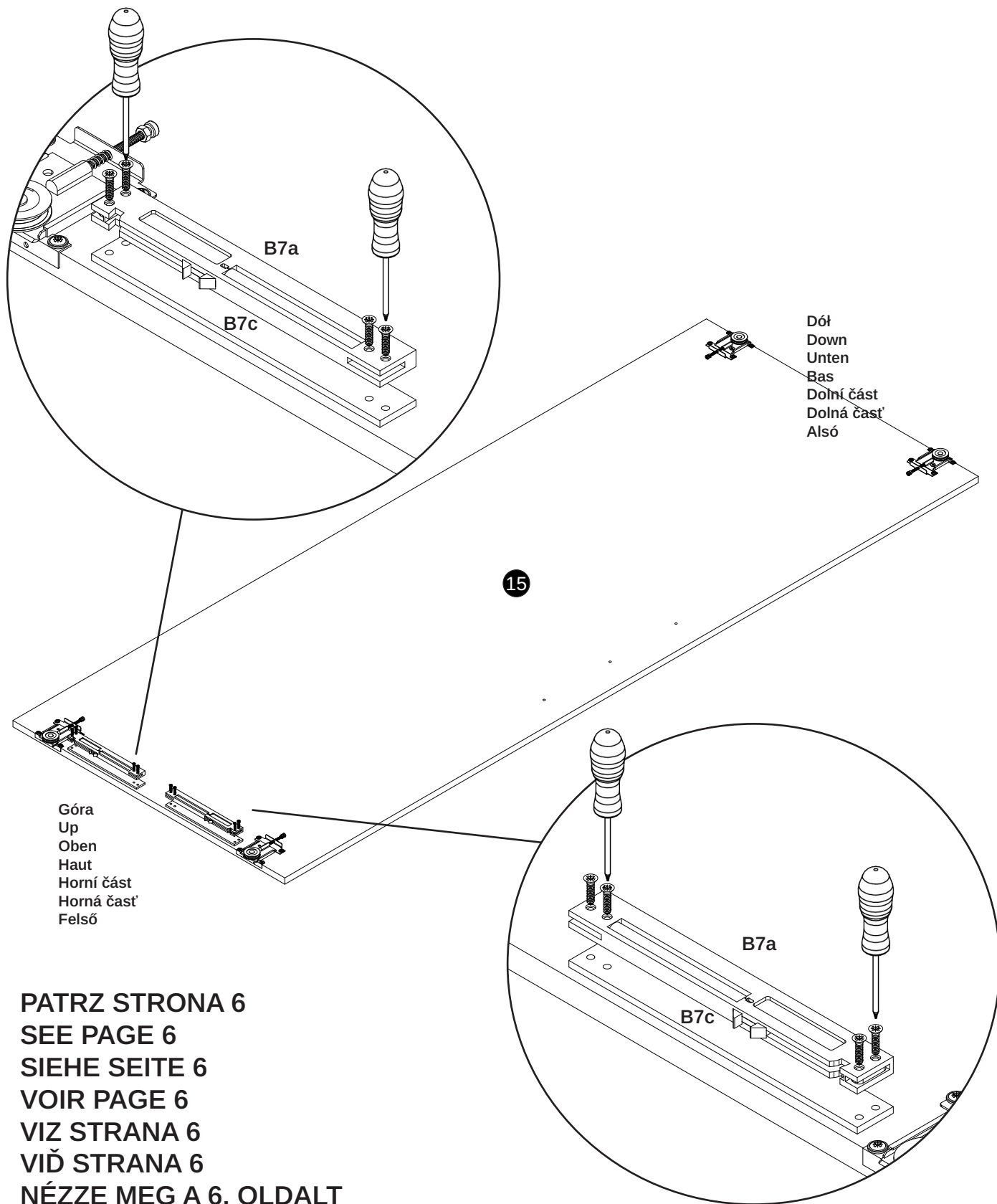
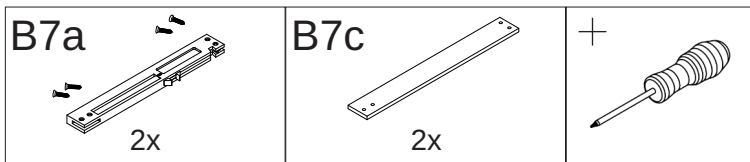

PATRZ STRONA 6  
SEE PAGE 6  
SIEHE SEITE 6  
VOIR PAGE 6  
VIZ STRANA 6  
VIĎ STRANA 6  
NÉZZE MEG A 6. OLDALT

# 24

ver 1 / ver 2 / ver 3

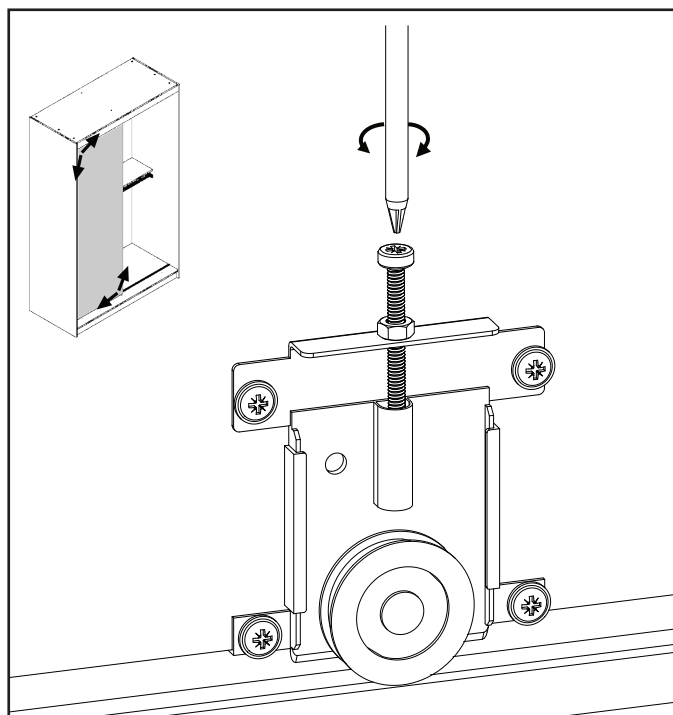
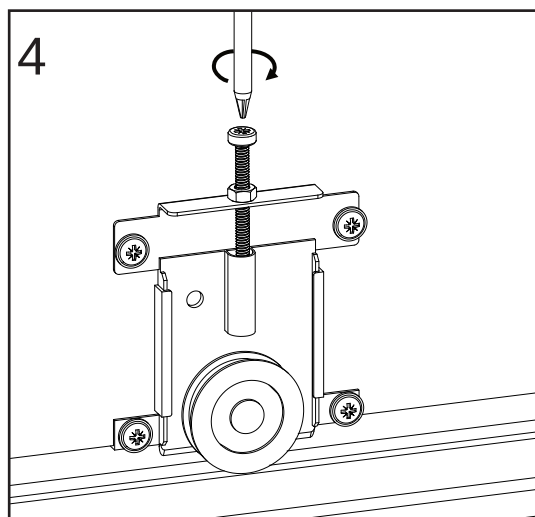
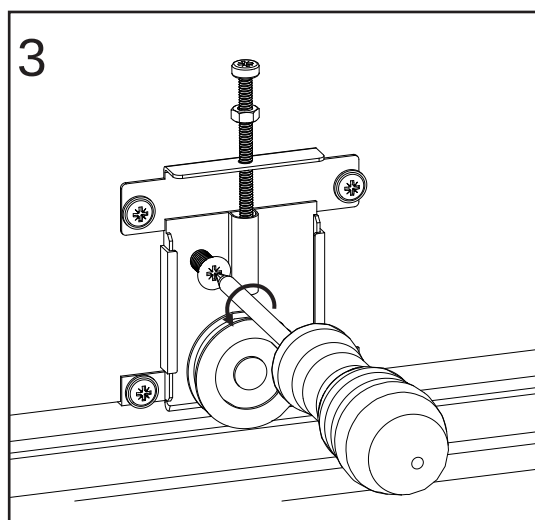
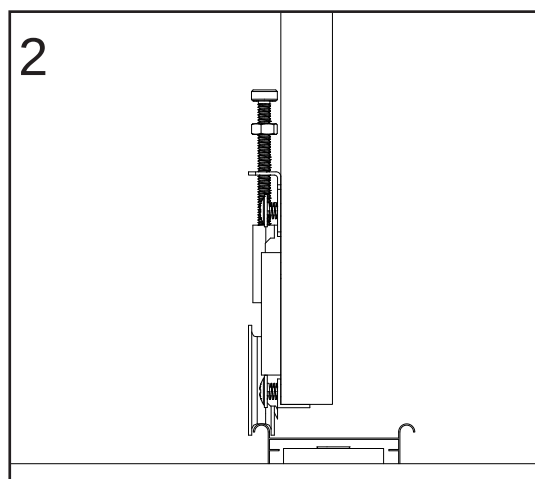
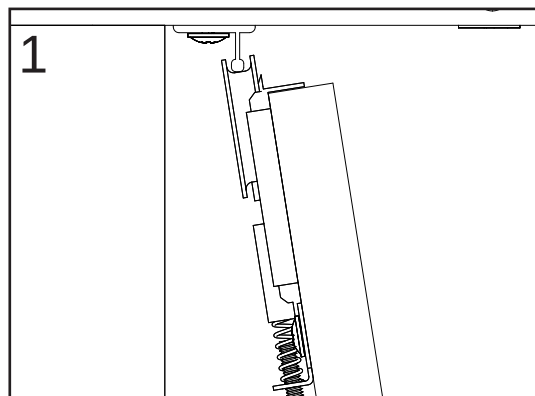
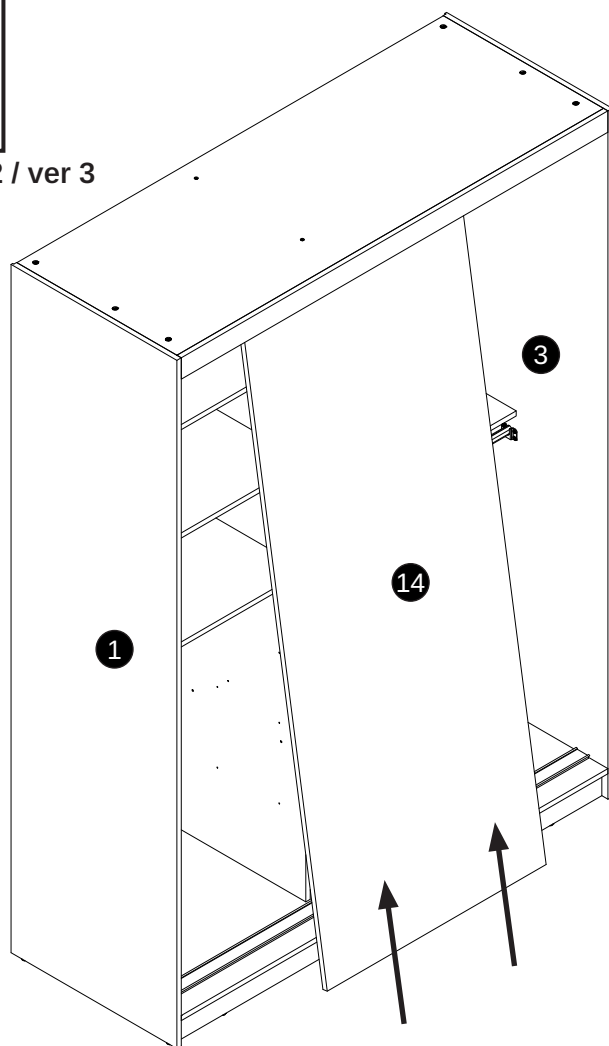

Bez prawidłowej regulacji NIE MOŻESZ użytkować szafy.  
The wardrobe cannot be used without being properly adjusted.  
Ohne richtige Einstellung KANNST DU den Schrank NICHT nutzen.  
Si le calibrage n'est pas correct, vous NE POUVEZ PAS utiliser l'armoire.  
Bez správné úpravy Skříň NEMŮŽETE používat.  
Bez správnjej úpravy Skriňu NEMÔŽETE používať.  
Megfelelő beállítás nélkül A szekrényt NEM HASZNÁLHATJA.

# 25

ver 1 / ver 2 / ver 3

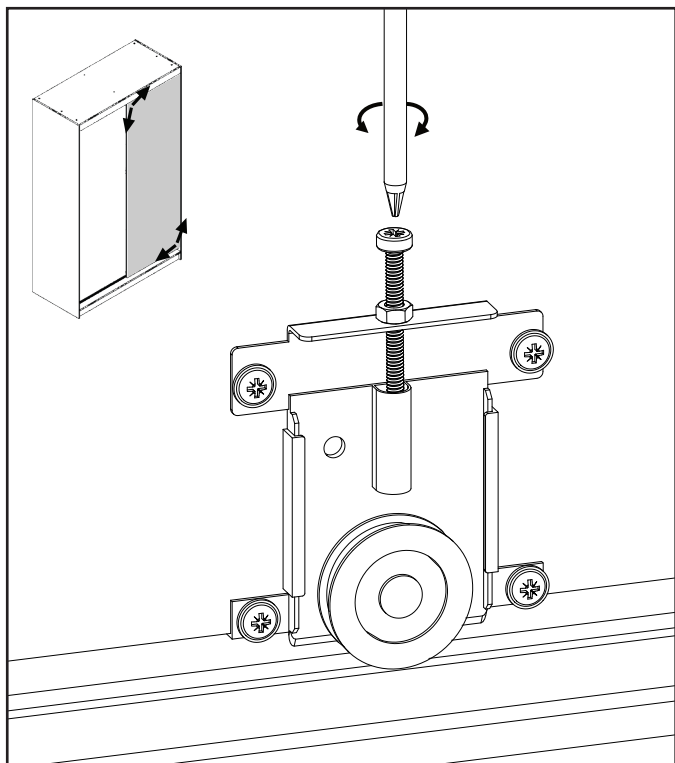
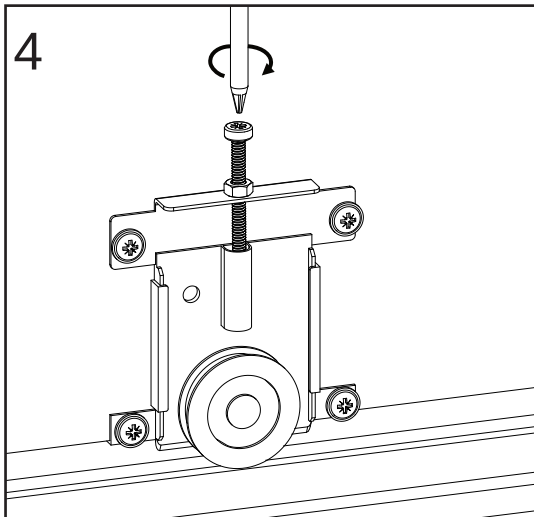
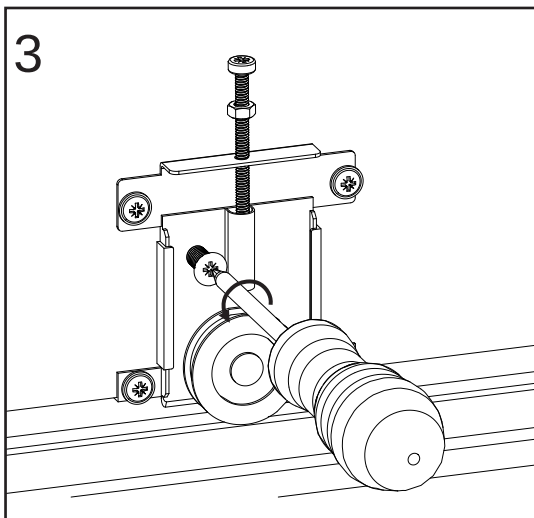
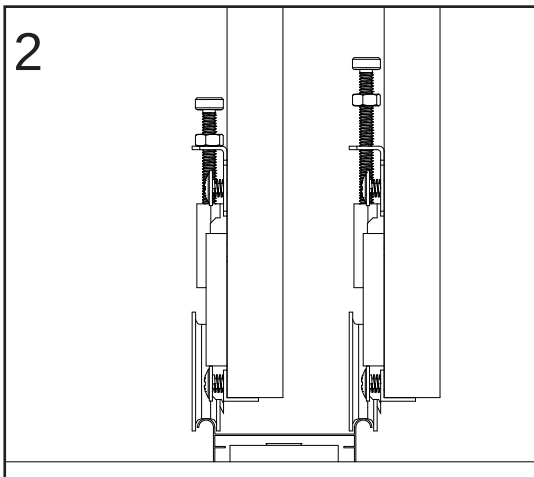
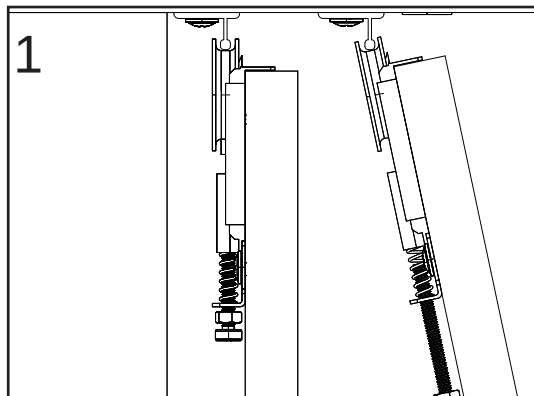
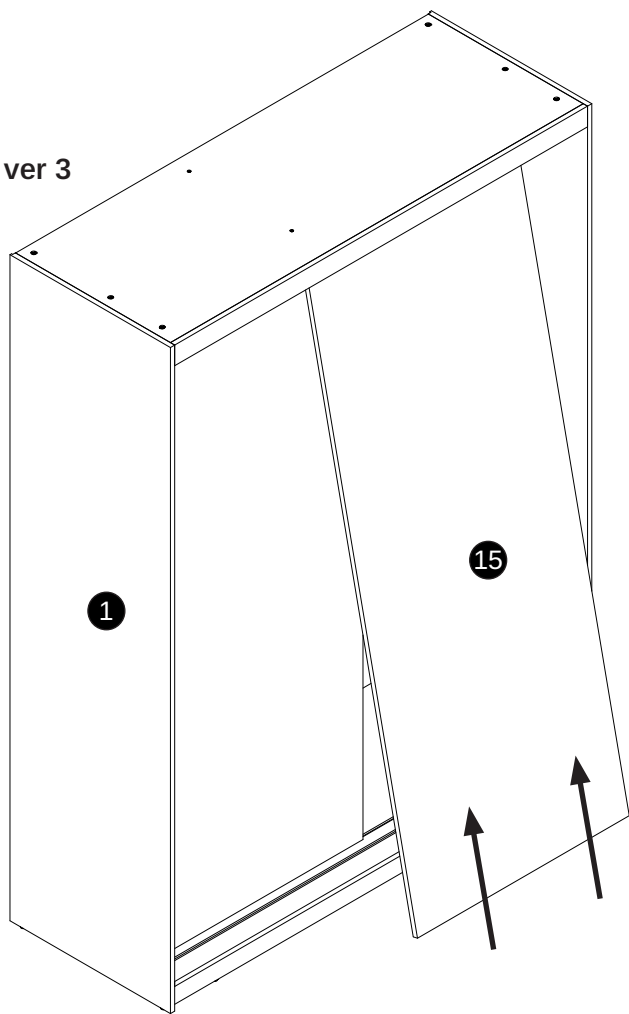

Bez prawidłowej regulacji NIE MOŻESZ użytkować szafy.  
The wardrobe cannot be used without being properly adjusted.  
Ohne richtige Einstellung KANNST DU den Schrank NICHT nutzen.  
Si le calibre n'est pas correct, vous NE POUVEZ PAS utiliser l'armoire.  
Bez správnej úpravy Skriň NEMŮŽETE používať.  
Bez správnej úpravy Skriňu NEMŮŽETE používať.  
Megfelelő beállítás nélkül A szekrényt NEM HASZNÁLHATJA.

**26**

M5



4x

ver 1

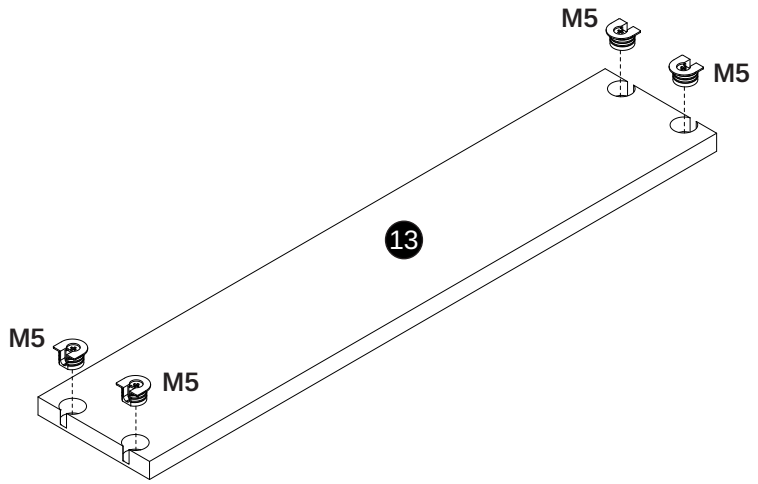

**27**

N4



4x

ver 1

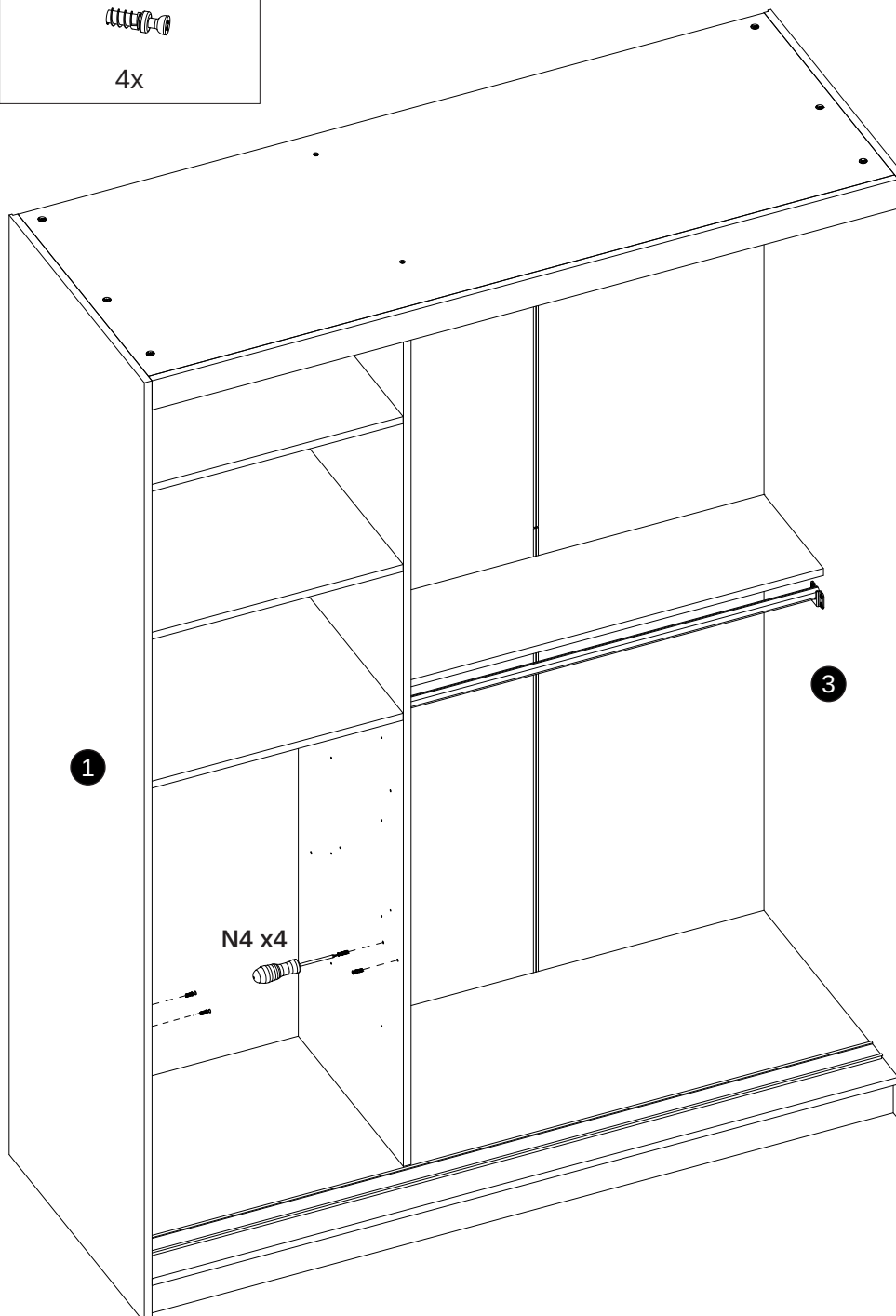
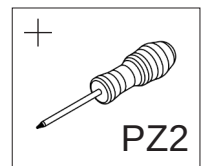

28

ver 1

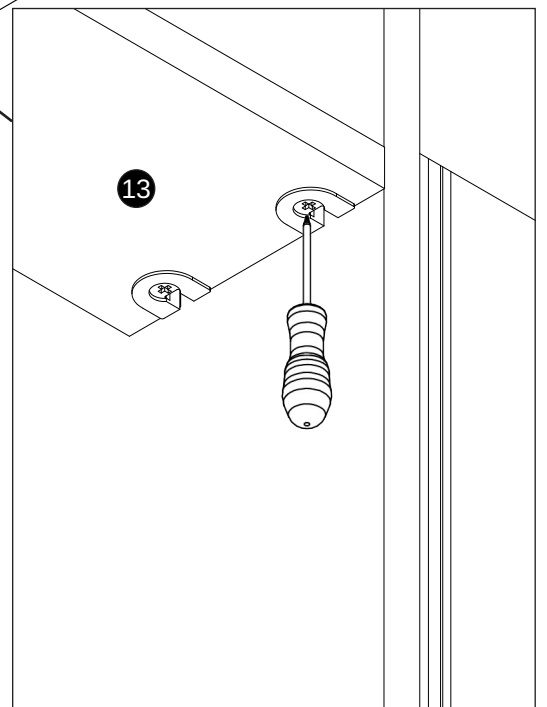
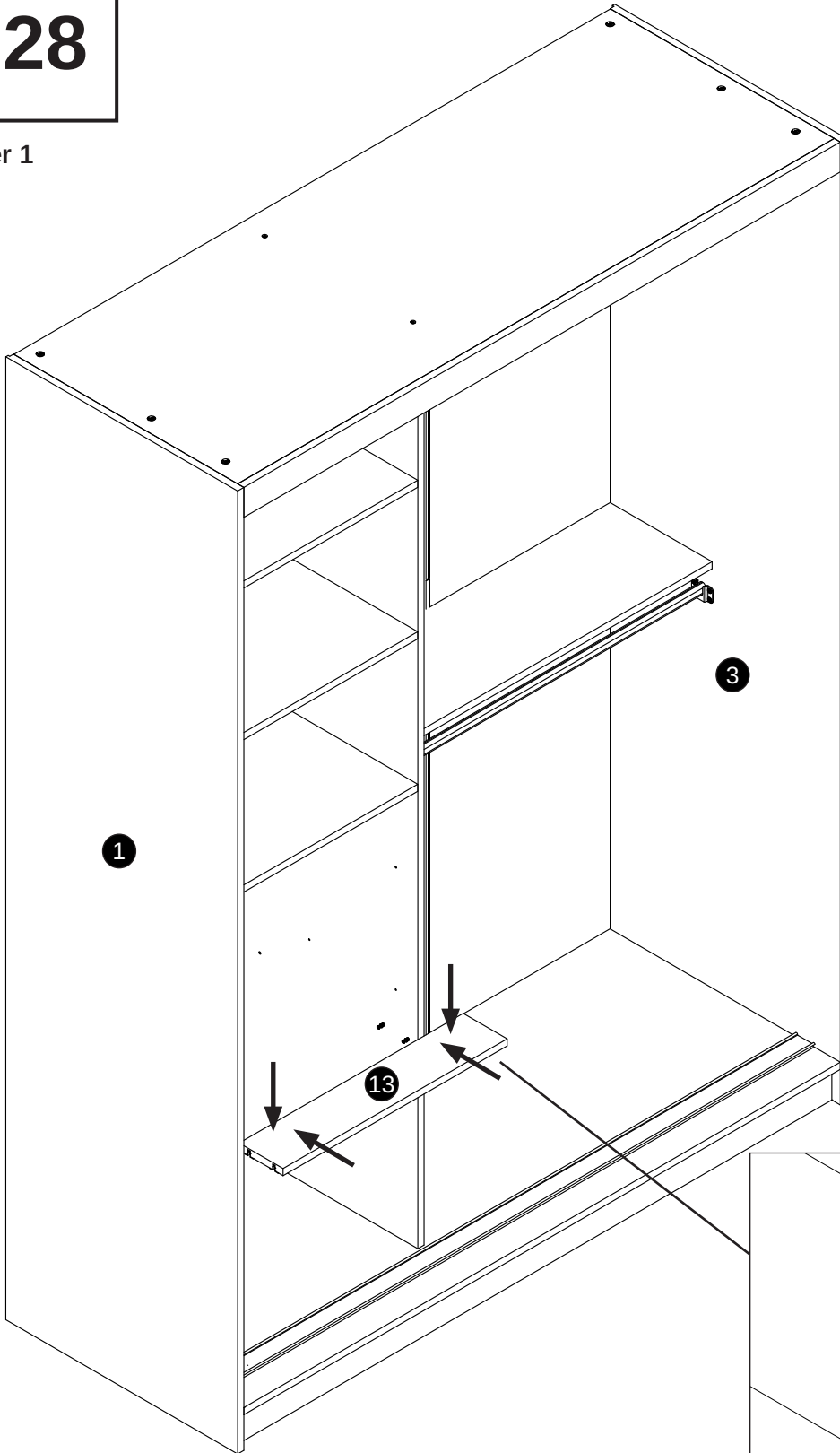
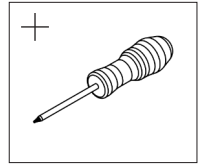

**29**

J5  
2x

S0b  
16x

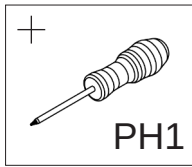

ver 1

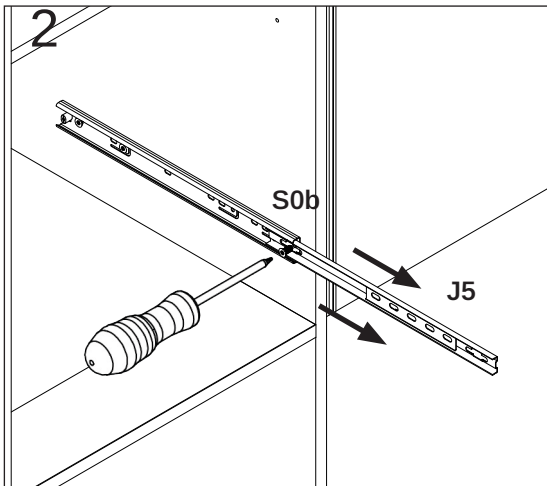
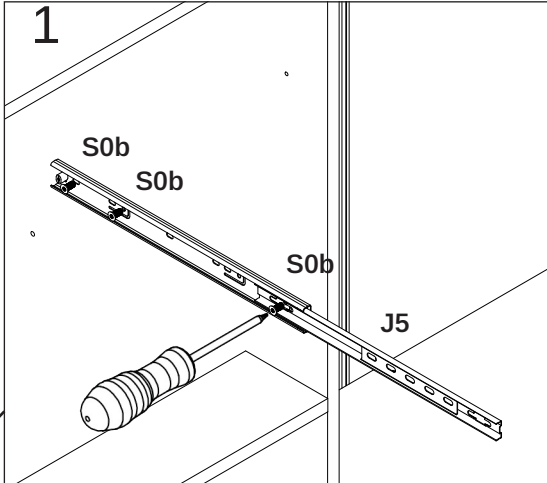
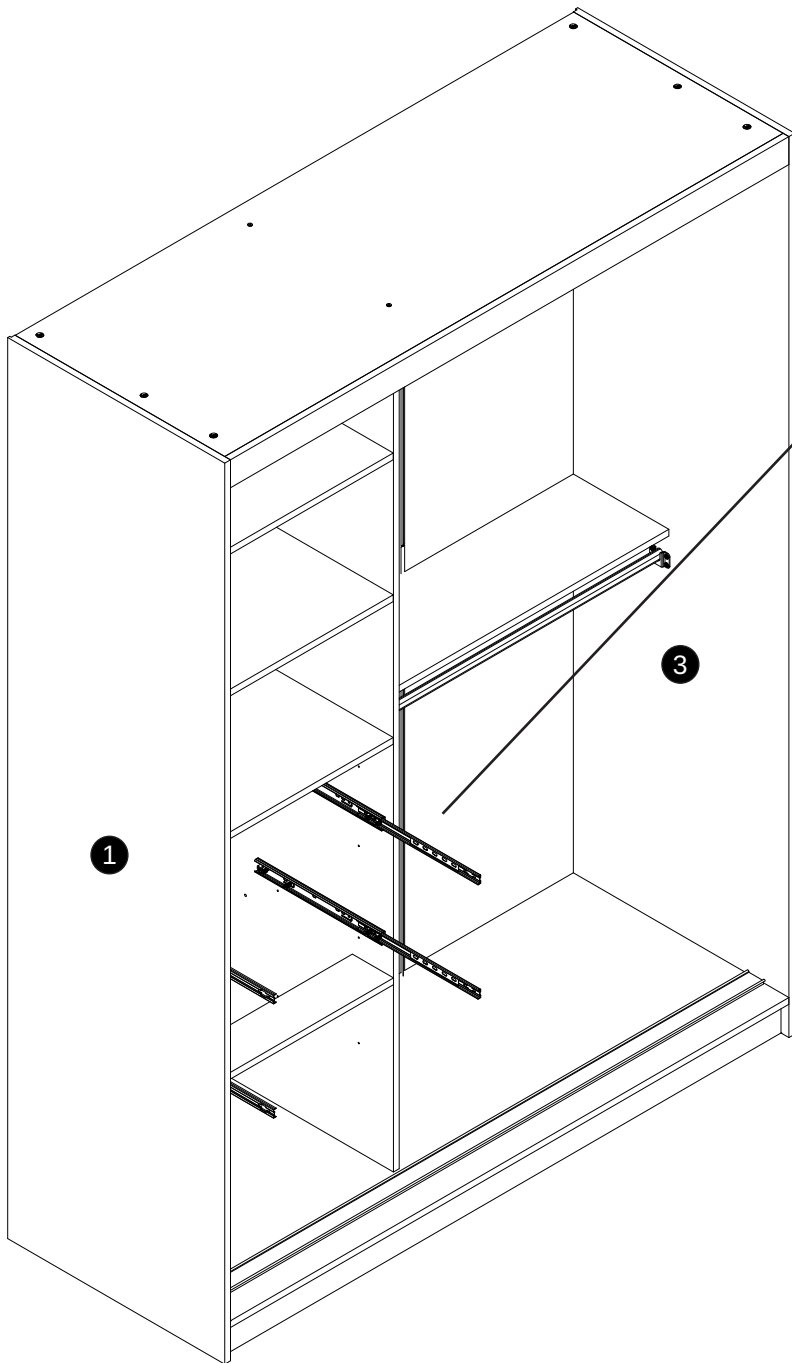

# 30

ver 1

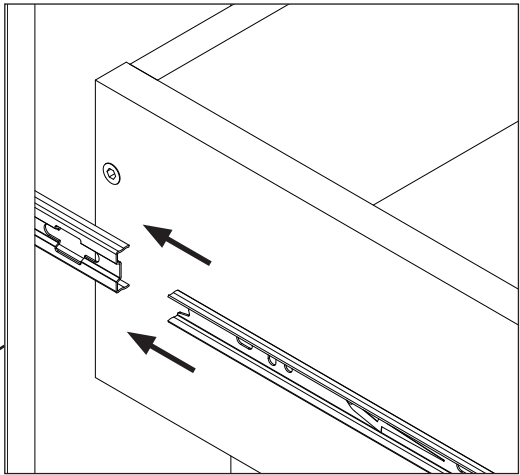
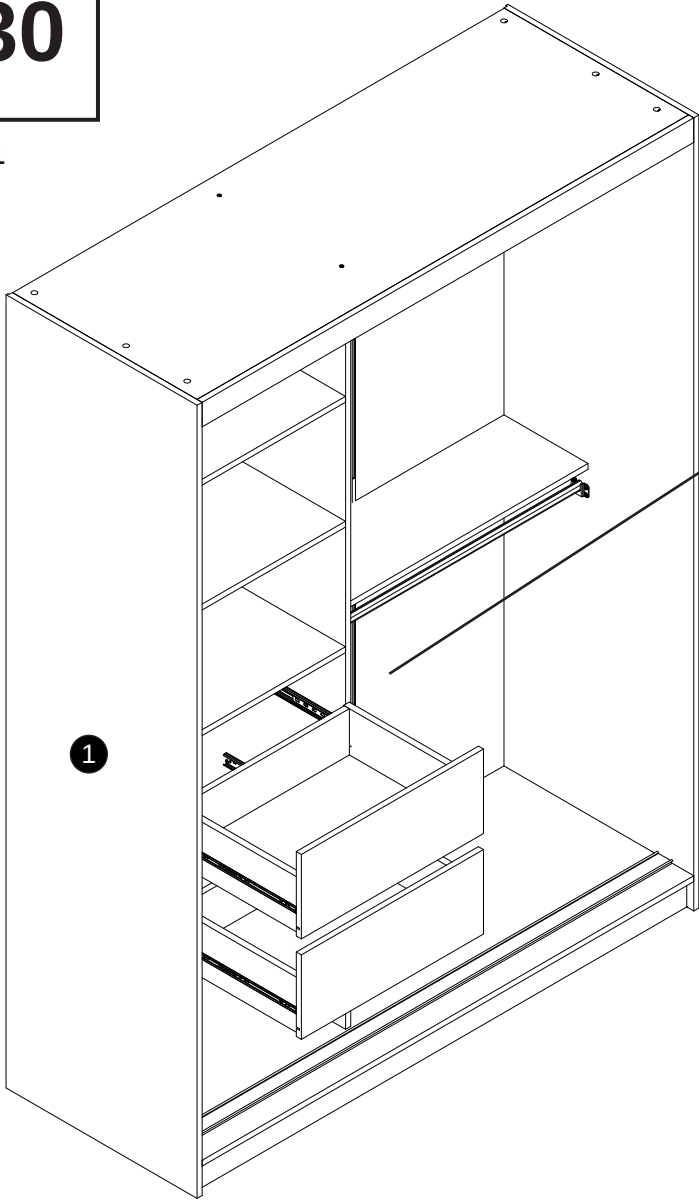

# 31

ver 2

M5  
  
4x

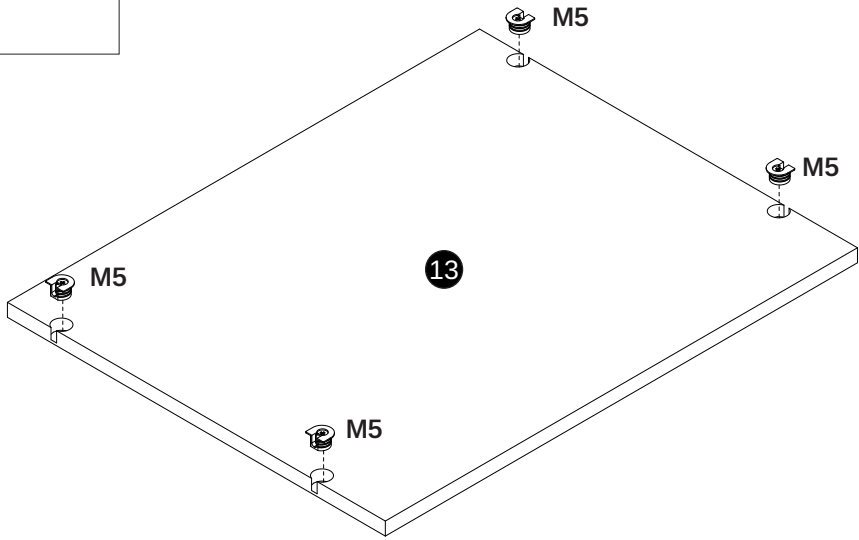

**32**

N4  
  
4x

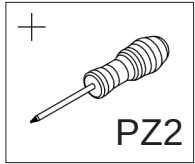

ver 2

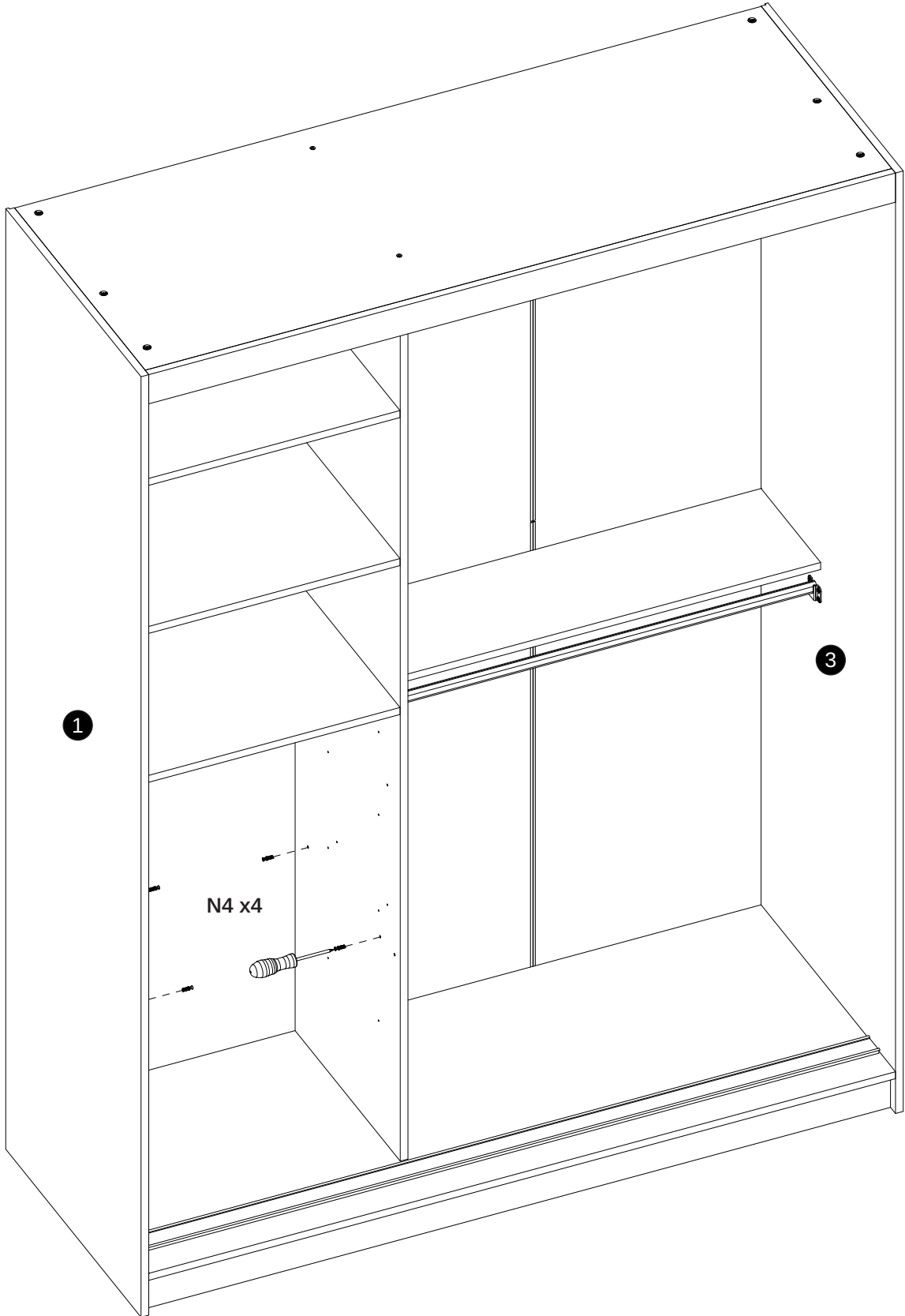

**33**

Z2  
  
x8

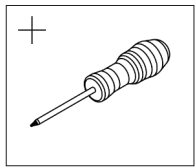

ver 2

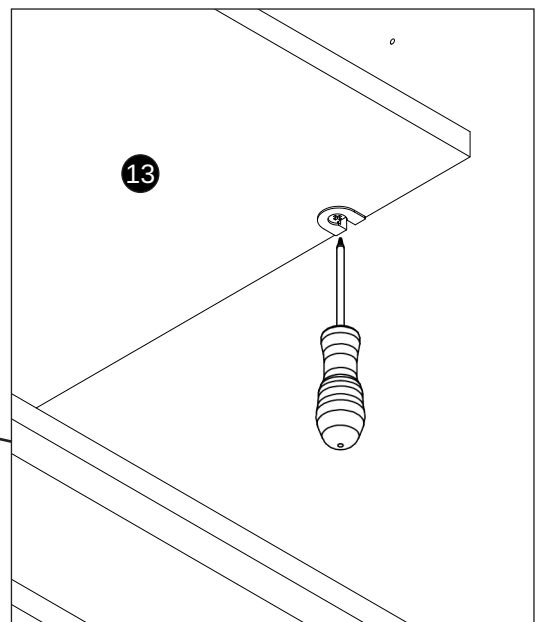
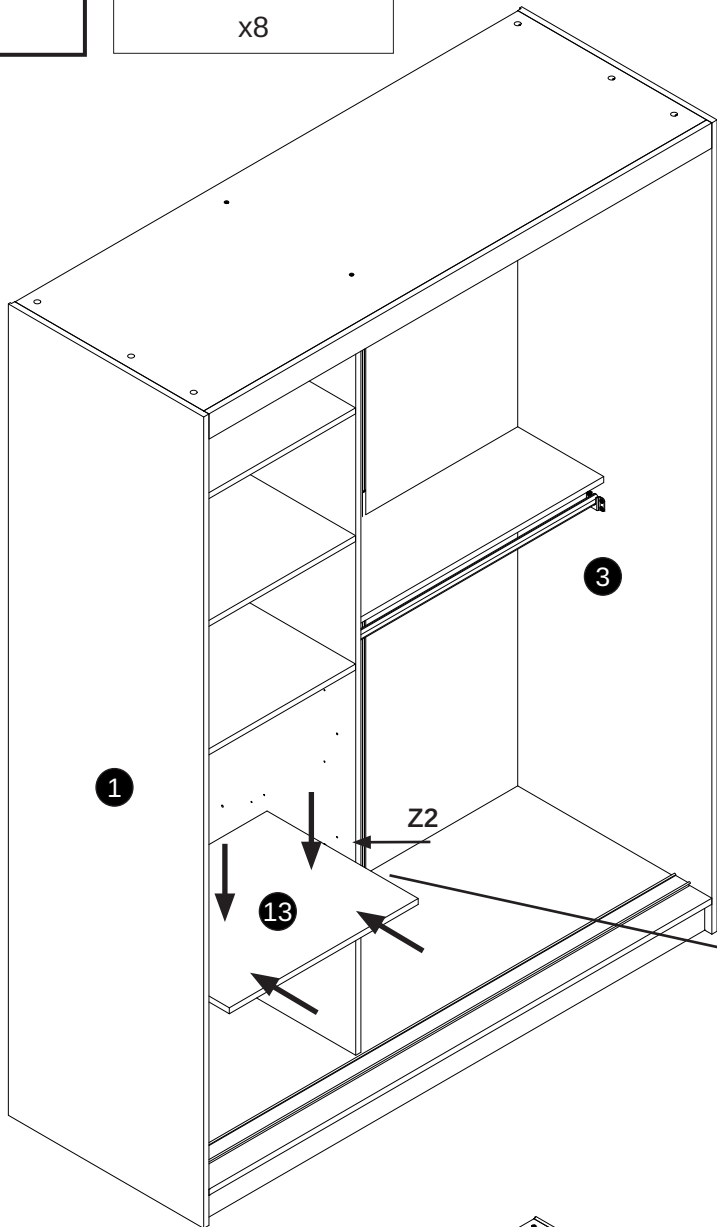

! ver 3

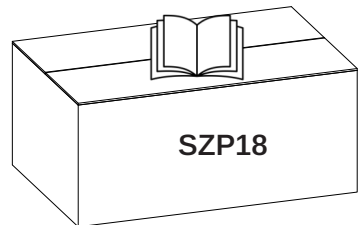
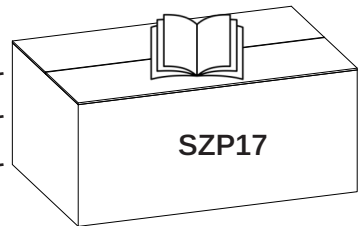
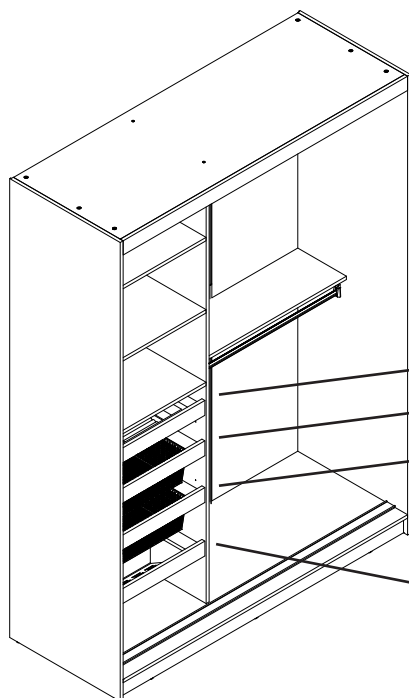

# 34

ver 1 / ver 2 / ver 3

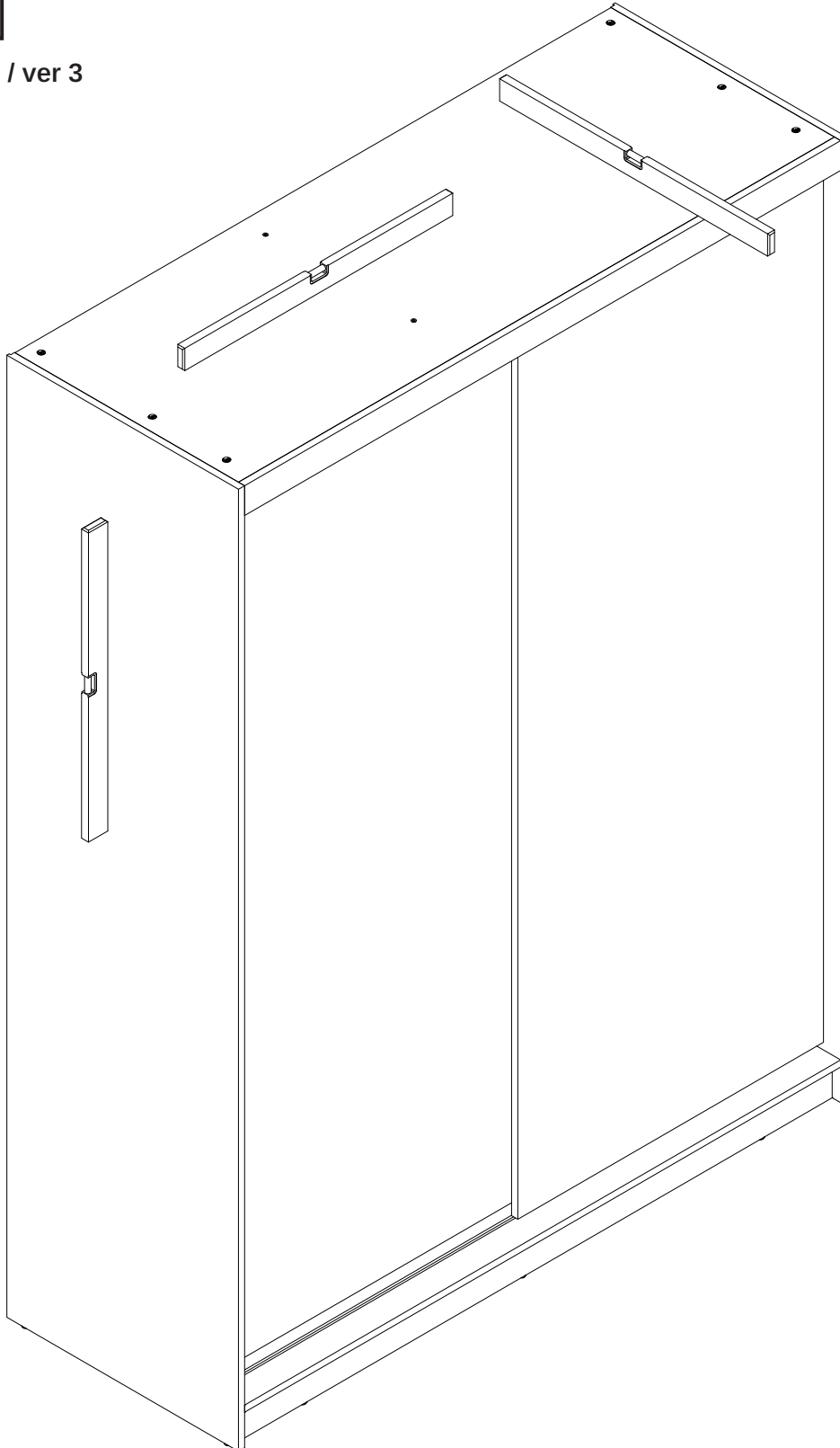
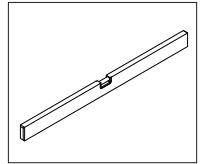

**Zasady użytkowania i konserwacji mebli**  
**Rules for the Use and Maintenance of Furniture**  
**Benutzungs- und Pflegehinweise für Möbel**  
**Règles d'utilisation et d'entretien des meubles**  
**Pravidla používání a údržby nábytku**  
**Pravidlá používania a údržby nábytku**  
**A bútorok használatának és karbantartásának szabályai**

<b>PL</b>	<ul style="list-style-type: none"> <li>• Meble należy użytkować w pomieszczeniach suchych, ogrzewanych zabezpieczonych przed szkodliwymi wpływami atmosferycznymi.</li> <li>• W trakcie użytkowania mebli należy okresowo sprawdzać stan połączeń technicznych takich jak: mimośrodry, zawiasy, prowadniki.</li> <li>• Podczas przenoszenia mebli należy chwytać wyłącznie za pionowe elementy konstrukcyjne takie jak boki, nogi. Bezwzględnie nie można chwytać za elementy poziome, takie jak blaty, półki, szuflady, gdyż grozi to poważnymi uszkodzeniami mebli.</li> <li>• Powierzchnię mebli należy czyścić wyłącznie środkami przeznaczonymi do pielęgnacji mebli.</li> </ul>
<b>EN</b>	<ul style="list-style-type: none"> <li>• Furniture should be kept in dry places which are heated and protected by harmful influence of atmospheric conditions.</li> <li>• While the furniture is in use there is a necessity to periodically check the state of the technical connections such as: eccentric rods, hinges, guides.</li> <li>• While furniture is carried it is necessary to keep only the vertical components, such as sides and legs of the furniture.</li> <li>• The surface of the furniture should be cleaned only with detergents for furniture care.</li> </ul>
<b>DE</b>	<ul style="list-style-type: none"> <li>• Die Möbel soll man in den trockenen, beheizten und vor den schädlichen Witterungseinflüssen gesicherten Räumen benutzen.</li> <li>• Im Laufe der Benutzung der Möbel soll man zeitlich den Zustand der technischen Verbindungen wie: Exzenter, Türbände und Leitstücke prüfen.</li> <li>• Während des Möbeltransports muss man ausschließlich nach vertikalen Konstruktionselementen wie: Ecken und Beine greifen. Auf keinen Fall darf man nach horizontalen Elementen, wie Blätter, Bretter und Schubladen greifen, was zur ernsthaften Möbelbeschädigung bringen kann.</li> <li>• Die Fläche der Möbel soll man nur mit dazu geeigneten Pflegemöbelmitteln putzen.</li> </ul>
<b>FR</b>	<ul style="list-style-type: none"> <li>• Les meubles doivent être utilisés dans des pièces sèches, chauffées et protégées contre les effets nocifs de la pollution. Les meubles doivent être utilisés dans des locaux secs, chauffés et protégés des influences atmosphériques nocives.</li> <li>• Lors de l'utilisation du mobilier, l'état des connexions techniques telles que: excentriques, charnières, guides.</li> <li>• Lorsque vous déplacez le meuble, ne manipulez que les éléments structurels verticaux, tels que les côtés, jambes. Vous ne devez absolument pas saisir les éléments horizontaux tels que les plateaux, les étagères, les tiroirs, car cela peut provoquer des dommages importants au mobilier.</li> <li>• La surface du meuble doit être nettoyée uniquement avec des produits destinés à l'entretien des meubles.</li> </ul>
<b>CZ</b>	<ul style="list-style-type: none"> <li>• Nábytek musí být umístěn v suchých, ohříváných místnostech a zajištěn před škodlivými povětrnostními vlivy.</li> <li>• Během používání nábytku je třeba pravidelně kontrolovat stav technických spojů jako jsou: panty nebo vodítka.</li> <li>• Při přesouvání nábytku chytajte pouze vertikální konstrukční části, jako jsou kraje a nohy. Absolutně nemůžete chytit horizontální části, jako jsou nábytkové desky, police, zásuvky, neboť to může způsobit vážné poškození nábytku.</li> <li>• Povrch nábytku je třeba čistit výhradně čistícími prostředky, které jsou k tomu určeny.</li> </ul>
<b>SK</b>	<ul style="list-style-type: none"> <li>• Nábytok musí byť umiestnený v suchých, ohrievaných miestnostiach a zabezpečený pred škodlivými poveternostnými vplyvmi.</li> <li>• V priebehu používania nábytku je potrebné pravidelne kontrolovať stav technických spojov ako sú: pánty, alebo vodidlá.</li> <li>• Pri presúvaní nábytku chytajte iba vertikálne konštrukčné časti, ako sú kraje a nohy. Absolútne nemôžete chytiť horizontálne časti, ako sú nábytkové dosky, police, zásuvky, pretože to môže spôsobiť vážne poškodenie nábytku.</li> <li>• Povrch nábytku je potrebné čistiť výhradne čistiacimi prostriedkami, ktoré sú na to určené.</li> </ul>
<b>HU</b>	<ul style="list-style-type: none"> <li>• A bútorokat száraz, fűtött helyiségben kell elhelyezni, és védeni kell a káros időjárás hatásától.</li> <li>• Az ingatlan használatá során rendszeresen ellenőrizni kell a műszaki csatlakozások állapotát, pl.: zsanérok vagy vezetők.</li> <li>• Bútor mozgatásakor csak a függőleges szerkezeti részeket, például éleket és lábakat fogja meg. Egyáltalán nem ragadhatja meg a vízszintes részeket, mint a bútorlapok, polcok, fiókok, mivel ez súlyos károkat okozhat a bútorban.</li> <li>• A bútor felületét kizárólag erre a célra szolgáló tisztítószerrel szabad tisztítani.</li> </ul>



## Szuflada (23x57,2x41,6 cm)

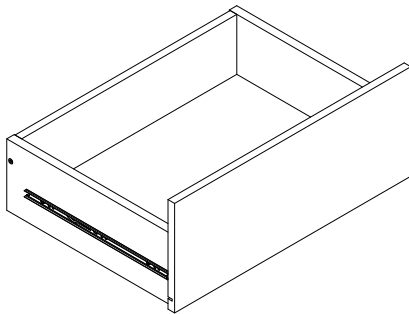

Ilość potrzebnych osób  
Number of people needed  
Benötigte Personenzahl  
Nombre de personnes nécessaires

Niezbędne narzędzia do montażu

Tools necessary for assembly

Notwendiges Werkzeug für die Montage

Outils nécessaires pour le montage

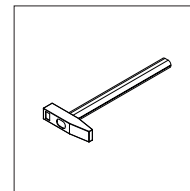
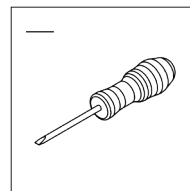
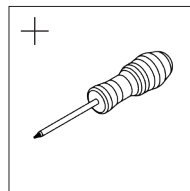

PL

- Przed przystąpieniem do montażu przeczytaj i zapoznaj się z całą instrukcją.
- Przestrzegaj bezwzględnie kolejnych kroków montażowych **1**, **2**, **3**...
- Nie wyrzucaj opakowania dopóki nie ukończysz skutecznie w całości montażu.
- Montaż wykonuj na płaskiej, miękkiej oraz czystej powierzchni takiej jak tektura.
- Bezwzględnie nie montuj elementów jeśli zauważysz ich wady lub uszkodzenia.
- Elementy montażowe takie jak okucia trzymaj w miejscu niedostępnym dla niemowląt i dzieci.
- Wadliwe lub uszkodzone elementy reklamuj podając ich numer z instrukcji montażu.
- Jeśli uszkodzony element będzie zamontowany reklamacja nie będzie uznana.

EN

- Read and get familiar with the whole instruction before the process of installation.
- Imperatively observe the consecutive assembly steps **1**, **2**, **3**...
- Do not throw away the packaging until the installation is successfully done.
- The installation should be done on the flat, soft and clear surface, such as cardboard.
- Under no circumstances should you install the elements in case of any faults or damage.
- The installation elements as fittings should be kept in a place unavailable for babies or children.
- Faulty or damaged components should be complaint by giving the number of the assembly instruction.
- If the damaged component is installed, the complaint will not be accepted.

DE

- Vor Beginn der Montage muss man die Instruktion genau durchlesen.
- Die aufeinanderfolgenden Montageschritte **1**, **2**, **3**... unbedingt beachten.
- Man muss die Packung behalten bis man die ganze Montage erfolgreich nicht beendet.
- Die Montage muss man auf einer glatten, weichen und sauberen Fläche ausüben
- Fehlerhafte oder beschädigte Elemente darf man auf keinen Fall montieren. Auf keinen Fall darf man fehlerhafte oder beschädigte Elemente montieren.
- Die Montageelemente wie Beschläge muss man unzugänglich von Babys und Kindern halten.
- Fehlerhafte oder beschädigte Elemente muss man nur mit Nummer der Instruktion reklamieren.
- Falls das beschädigte Element montiert wird, wird die Reklamation nicht berücksichtigt.







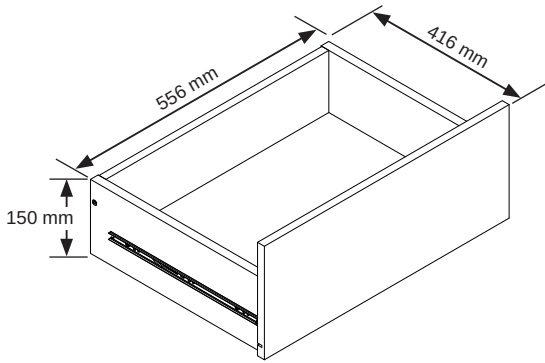

FR

- Avant de commencer le montage, lire et prendre connaissance de l'intégralité du manuel.
- Respectez scrupuleusement les étapes d'installation suivantes **1**, **2**, **3**...
- Ne pas jeter l'emballage avant d'avoir terminé l'assemblage.
- Le montage doit être effectué sur une surface plane, souple et propre, comme du carton.
- Ne pas assembler si vous remarquez des défauts ou des dommages.
- Garder les éléments de montage tels que les raccords hors de portée des bébés et des enfants.
- Réclamer les pièces défectueuses ou endommagées en citant le numéro figurant dans les instructions de montage.
- Si l'article endommagé est installé, la plainte ne sera pas acceptée.

# SZUFLADA

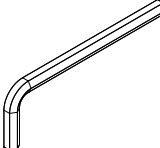

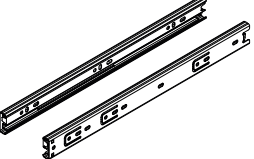
## Okucia / Fittings / Beschläge / Embouts

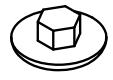
		Okucia / Fittings / Beschläge / Embouts	
		N2  x4	M3  x4
E1  x12	F1  7x50mm x4	K2  x1	D15  x10
J5  x2	S0b  3x16mm x18	M2  x4	F10  x4

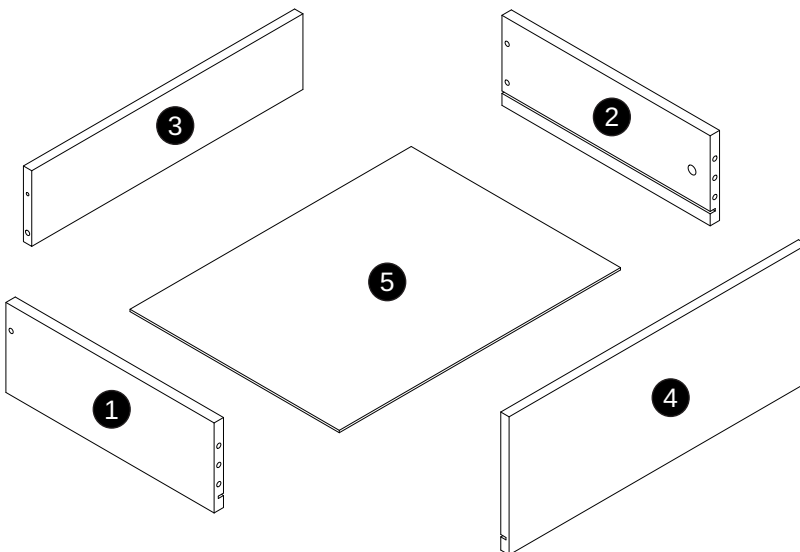

SZUFLADA	
1	2x (400x150mm)
2	2x (400x150mm)
3	2x (524x126mm)
4	2x (572x230mm)
5	2x (541x408mm)

Sposób montażu elementów N2 i M3  
 Method of assembling elements N2 and M3  
 Art der Montage von Elementen N2 und M3  
 Méthode d'assemblage de composants N2 et M3

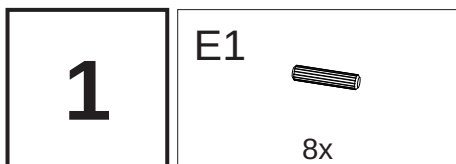
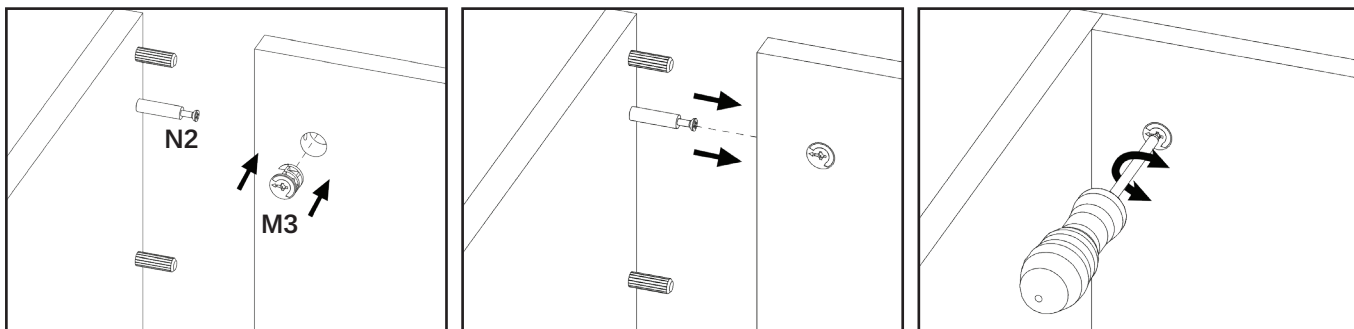

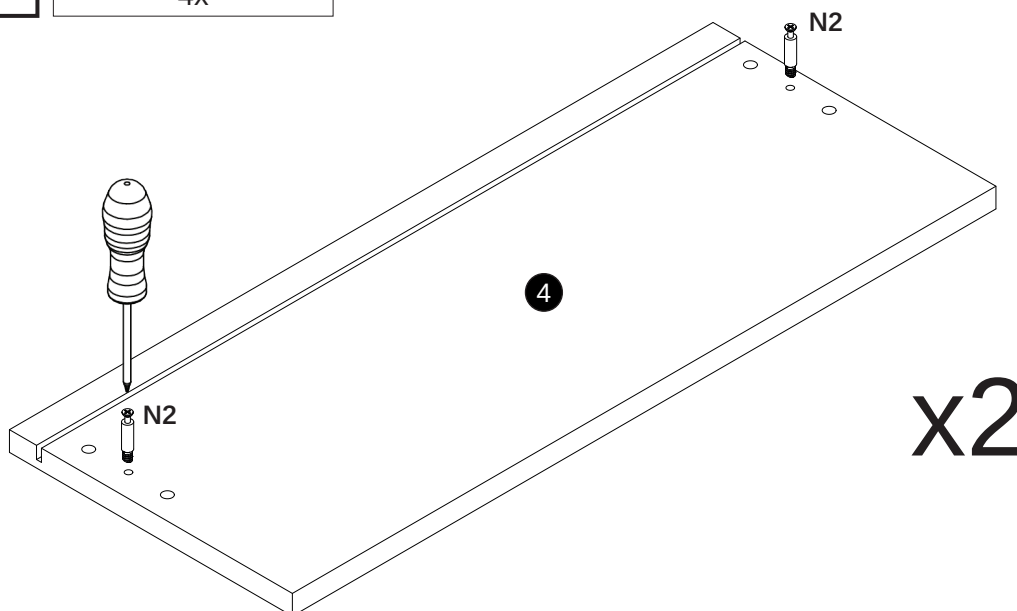
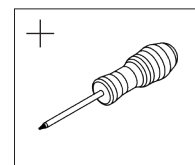
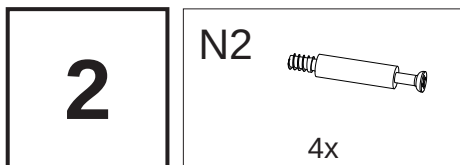
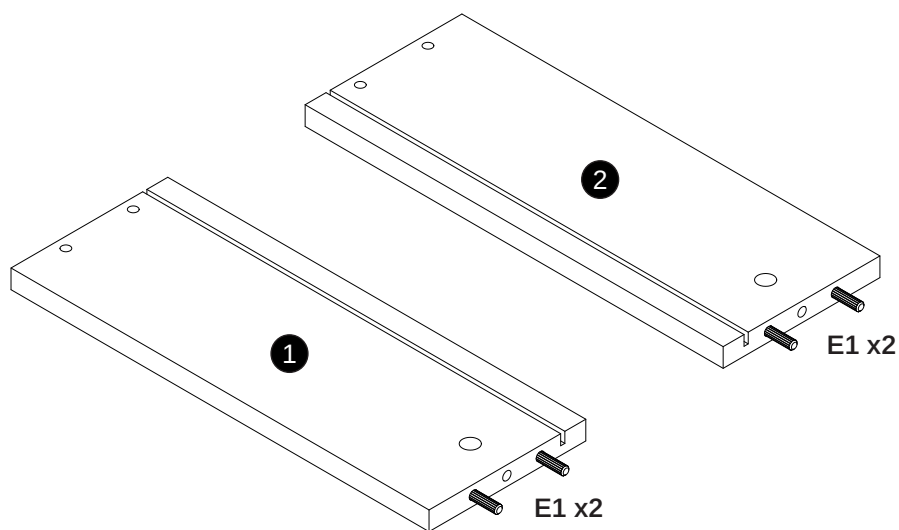

x2

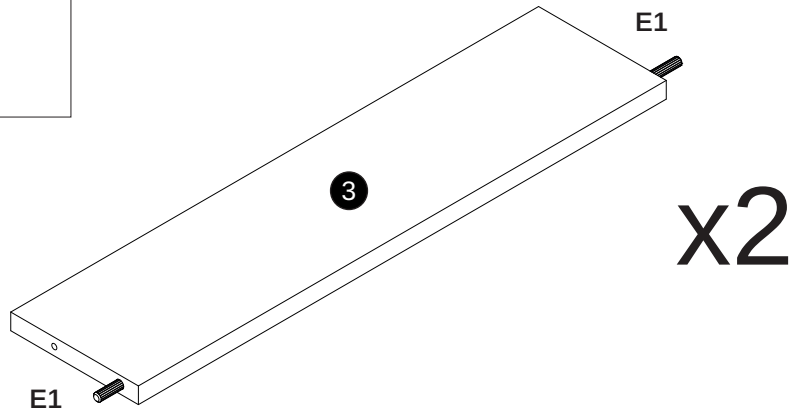

x2

<b>3</b>	E1 
	4x

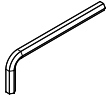

<b>4</b>	F1 	K2 
	4x	1x

x2

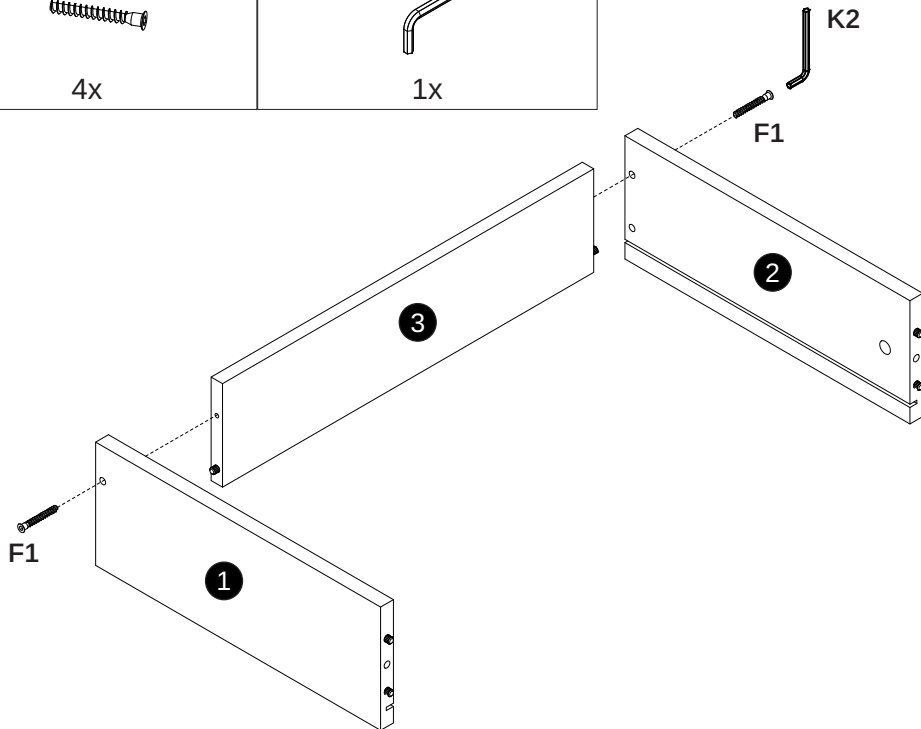



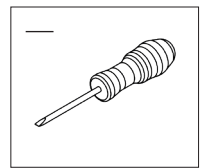

<b>5</b>	M3 
	4x

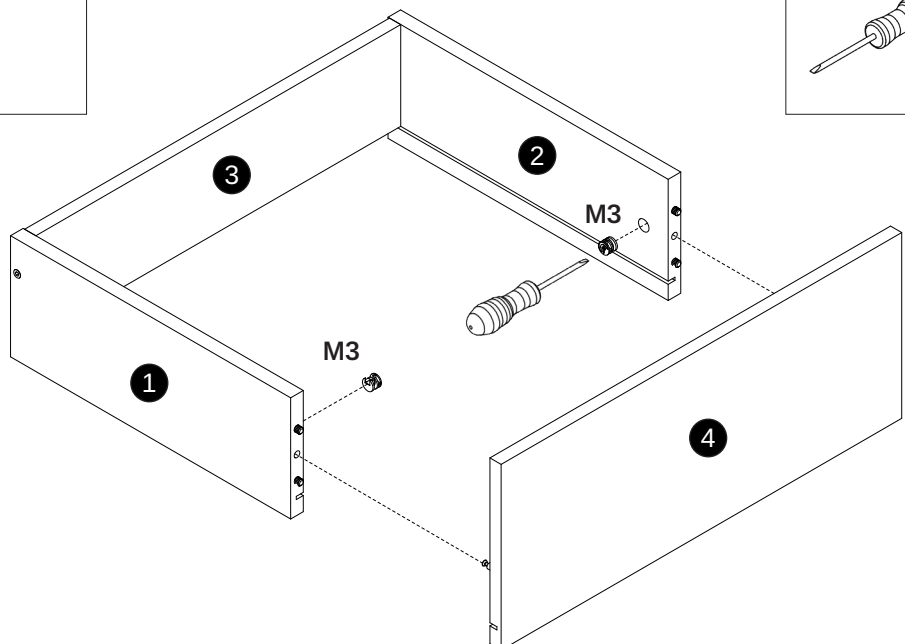

x2



<b>6</b>	<b>S0b</b>  10x	<b>D15</b>  10x	<b>M2</b>  4x	<b>F10</b>  4x
----------	--------------------------------------------------------------------------------------------------------	--------------------------------------------------------------------------------------------------------	-------------------------------------------------------------------------------------------------------	---------------------------------------------------------------------------------------------------------

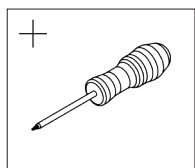

x2

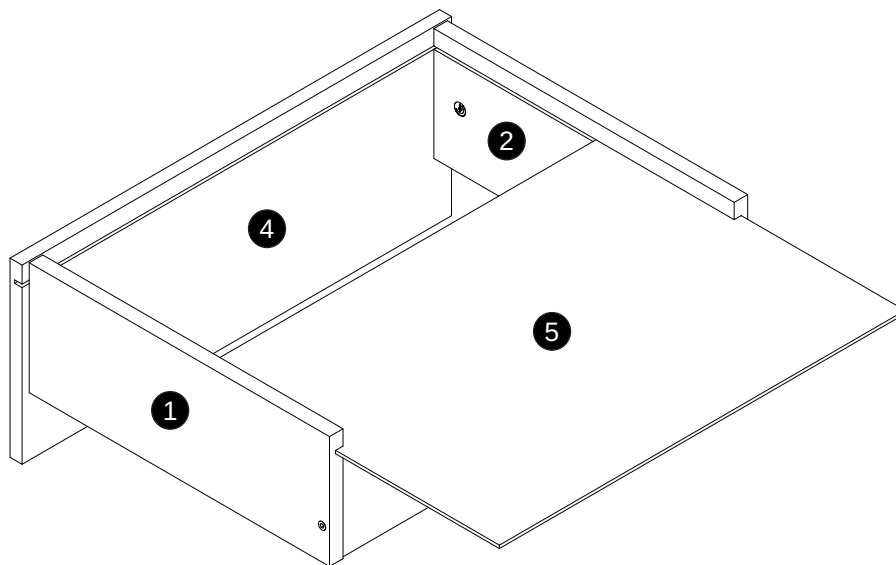

Bez sprawdzenia prawidłowych przekątnych  
**NIE MOŻESZ** kontynuować dalej montażu.

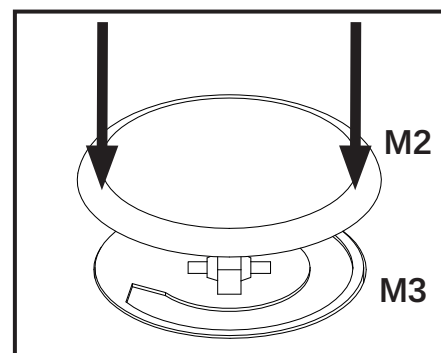
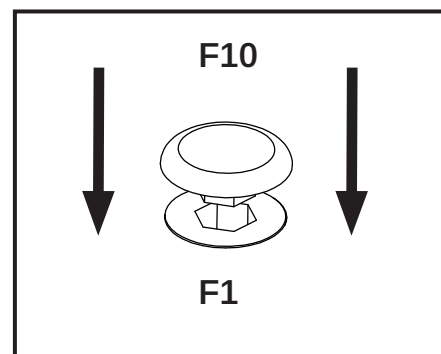
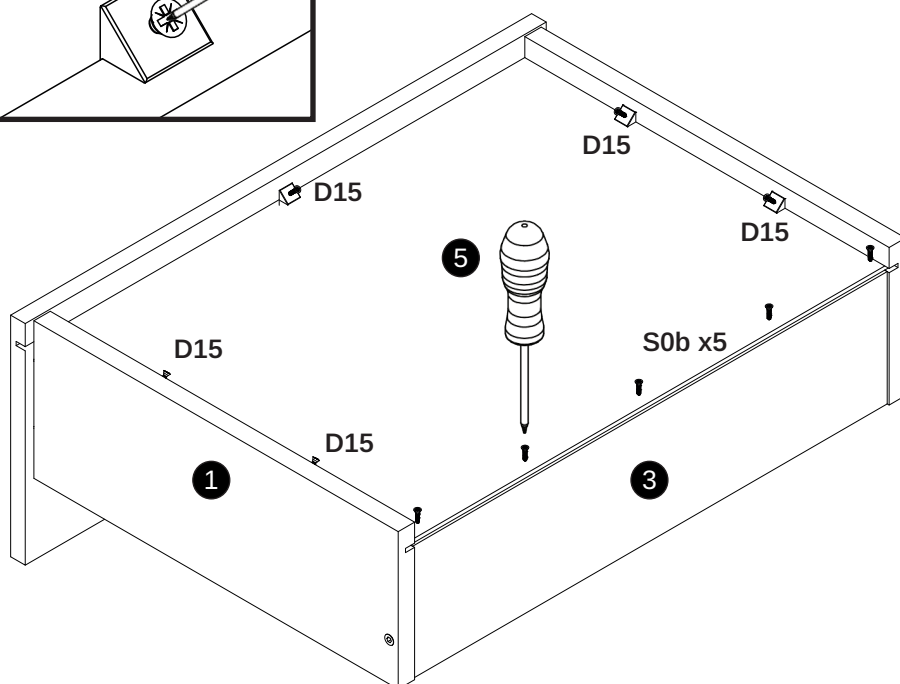
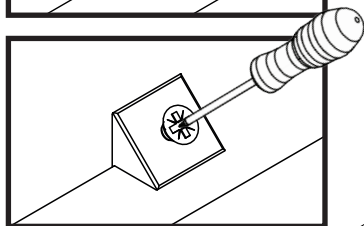
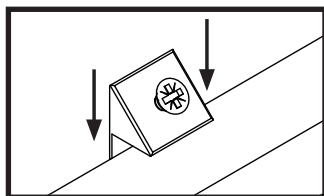
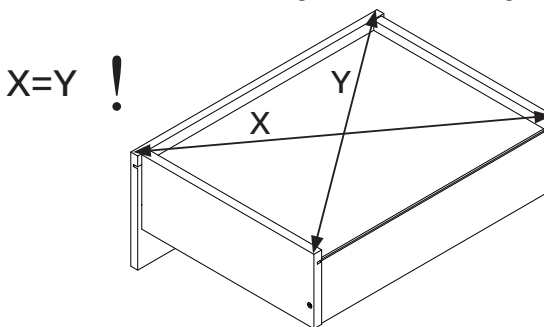

7

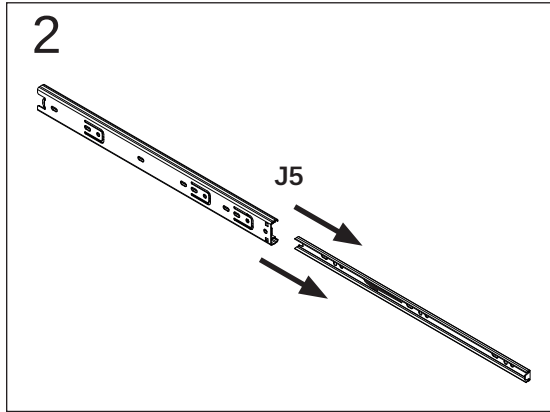
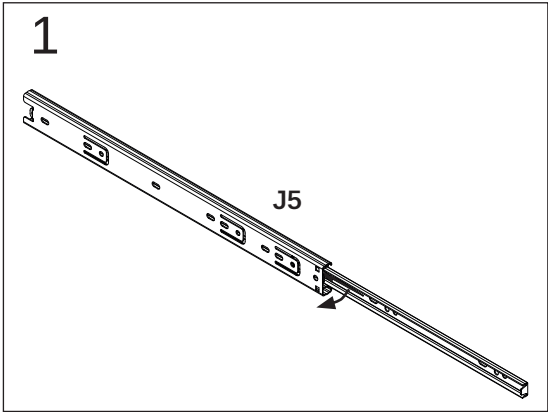
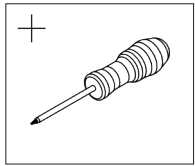
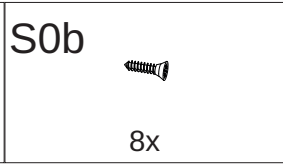
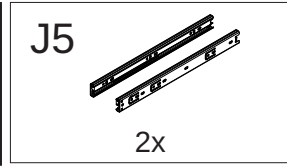

x2

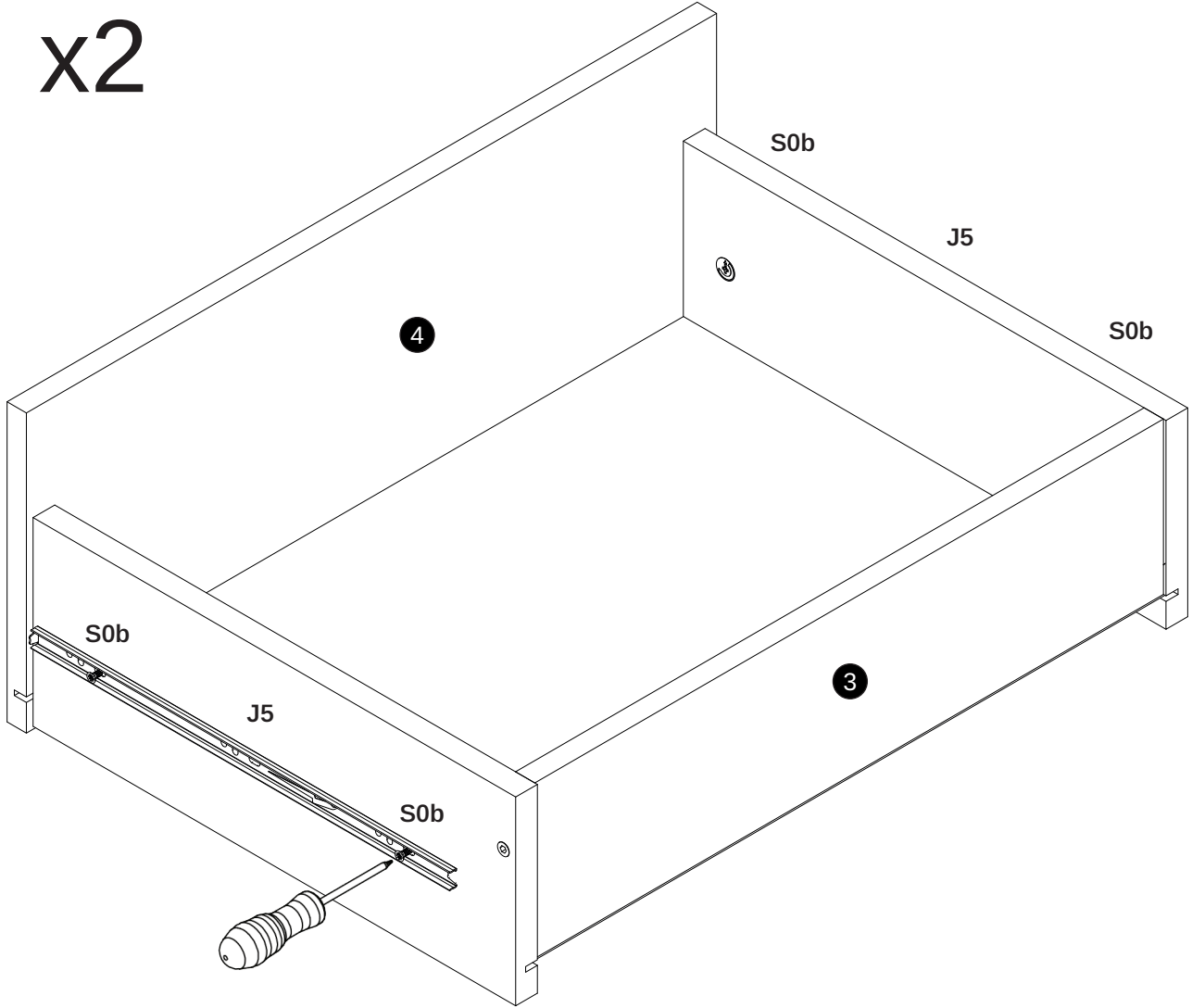

# Zasady użytkowania i konserwacji mebli

PL

- Meble należy użytkować w pomieszczeniach suchych, ogrzewanych zabezpieczonych przed szkodliwymi wpływami atmosferycznymi.
- W trakcie użytkowania mebli należy okresowo sprawdzać stan połączeń technicznych takich jak: mimośrod, zawiasy, prowadniki.
- Podczas przenoszenia mebli należy chwycić wyłącznie za pionowe elementy konstrukcyjne takie jak boki, nogi. Bezwzględnie nie można chwycić za elementy poziome, takie jak blaty, półki, szuflady, gdyż grozi to poważnymi uszkodzeniami mebli.
- Powierzchnię mebli należy czyścić wyłącznie środkami przeznaczonymi do pielęgnacji mebli.

EN

- Furniture should be kept in dry places which are heated and protected by harmful influence of atmospheric conditions.
- While the furniture is in use there is a necessity to periodically check the state of the technical connections such as: eccentric rods, hinges, guides.
- While furniture is carried it is necessary to keep only the vertical components, such as sides and legs of the furniture.
- The surface of the furniture should be cleaned only with detergents for furniture care.

DE

- Die Möbel soll man in den trockenen, beheizten und vor den schädlichen Witterungseinflüssen gesicherten Räumen benutzen.
- Im Laufe der Benutzung der Möbel soll man zeitlich den Zustand der technischen Verbindungen wie: Exzenter, Türbände und Leitstücke prüfen.
- Während des Möbeltransports muss man ausschließlich nach vertikalen Konstruktionselementen wie: Ecken und Beine greifen. Auf keinen Fall darf man nach horizontalen Elementen, wie Blätter, Bretter und Schubladen greifen, was zur ernsthaften Möbelbeschädigung bringen kann.
- Die Fläche der Möbel soll man nur mit dazu geeigneten Pflegemöbelmitteln putzen.

FR

- Les meubles doivent être utilisés dans des pièces sèches, chauffées et protégées contre les effets nocifs de la pollution. Les meubles doivent être utilisés dans des locaux secs, chauffés et protégés des influences atmosphériques nocives.
- Lors de l'utilisation du mobilier, l'état des connexions techniques telles que: excentriques, charnières, guides.
- Lorsque vous déplacez le meuble, ne manipulez que les éléments structurels verticaux, tels que les côtés, jambes. Vous ne devez absolument pas saisir les éléments horizontaux tels que les plateaux, les étagères, les tiroirs, car cela peut provoquer des dommages importants au mobilier.
- La surface du meuble doit être nettoyée uniquement avec des produits destinés à l'entretien des meubles.