

Montageanleitung | Instructions de montage Assembly Instructions | Instructions de montage

N616P390108W
N616P390109W
N616P390110W

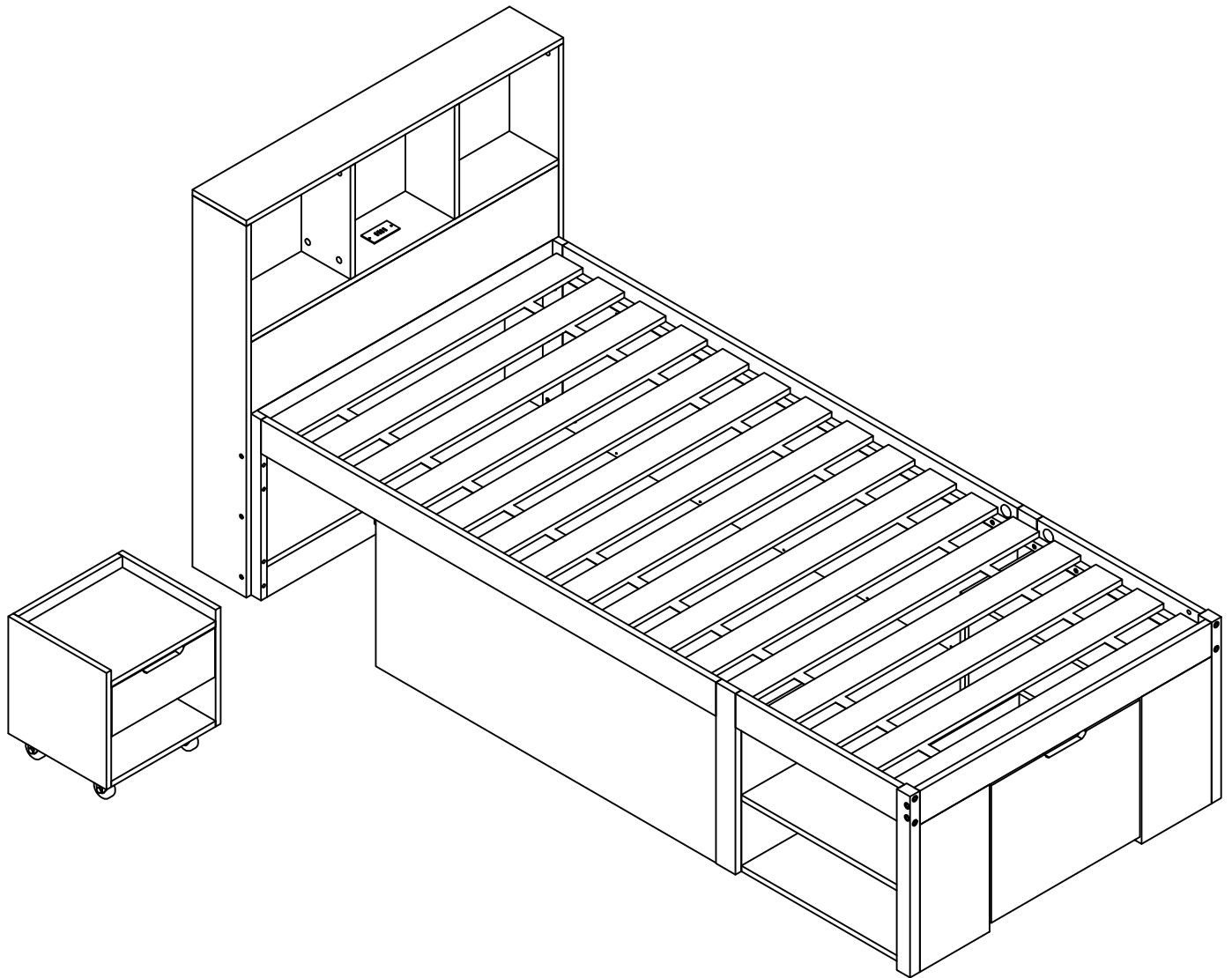

(GB) This set comes in 3 boxes. If you do not receive a full set of 3 boxes, please contact our customer service.

(DE) Dieses Set wird in 3 Schachteln geliefert. Wenn Sie nicht ein komplettes Set von 3 Boxen erhalten, kontaktieren Sie bitte unseren Kundenservice.

(FR) Ce set est livré en 3 boîtes. Si vous ne recevez pas un jeu complet de 3 boîtes, veuillez contacter notre service clientèle.

English

IMPORTANT ! KEEP FOR FUTURE REFERENCE : READ CAREFULLY

- To be assembled by an adult. Assembly must be checked by an adult before use
- WARNING ! Keep all screws, small parts and plastic bags out of the reach of children
- Properly identify all parts before assembling
- Never use your item if any of its parts are broken or missing
- Should any problems arise, please contact our After Sales Service
- Manufacturer's instructions shall be followed at all times
- Care: Clean with a soft, dry cloth. In case of larger stains, carefully rub with a slightly damp, non-abrasive sponge
- Avoid the risk of fire by not placing furniture near sources of ignition or hot items
- Do not jump on the bed

Deutsch

WICHTIG ! ZUM SPÄTEREN NACHSCHLAGEN AUFBEWAHREN: SORGFÄLTIG LESEN

- Muss von einem Erwachsenen zusammengebaut werden. Der Zusammenbau muss vor dem Gebrauch von einem Erwachsenen überprüft werden
- WARNUNG! Bewahren Sie alle Schrauben, Kleinteile und Plastikbeutel außerhalb der Reichweite von Kindern auf
- Kennzeichnen Sie vor dem Zusammenbau alle Teile richtig
- Benutzen Sie Ihren Artikel niemals, wenn Teile gebrochen sind oder fehlen
- Sollten Probleme auftreten, wenden Sie sich bitte an unseren Kundendienst
- Die Anweisungen des Herstellers sind stets zu befolgen
- Pflege: Mit einem weichen, trockenen Tuch reinigen. Bei größeren Flecken vorsichtig mit einem leicht feuchten, nicht scheuernden Schwamm abreiben. nicht scheuernden Schwamm
- Vermeiden Sie die Gefahr eines Brandes, indem Sie die Möbel nicht in der Nähe von Zündquellen oder heißen Gegenständen aufstellen
- Nicht auf das Bett springen

Français

IMPORTANT ! CONSERVER POUR RÉFÉRENCE ULTÉRIEURE : LIRE ATTENTIVEMENT

- Le montage doit être effectué par un adulte. Le montage doit être vérifié par un adulte avant Utilisation
- ATTENTION ! Tenir les vis, les petites pièces et les sachets en plastique hors de portée des enfants
- Identifiez correctement toutes les pièces avant de les assembler
- N'utilisez jamais votre article si l'une de ses pièces est cassée ou manquante
- En cas de problème, veuillez contacter notre service après-vente
- Les instructions du fabricant doivent être respectées à tout moment
- Entretien : nettoyer avec un chiffon doux et sec. En cas de taches plus importantes, frotter soigneusement avec une éponge non abrasive légèrement humide. légèrement humide et non Abrasive
- Évitez les risques d'incendie en ne plaçant pas les meubles à proximité de sources d'inflammation ou d'objets chauds
- Ne pas sauter sur le lit

Italiano

IMPORTANTE! CONSERVARE PER RIFERIMENTO FUTURO: LEGGERE ATTENTAMENTE

- Deve essere assemblato da un adulto. L'assemblaggio deve essere controllato da un adulto prima dell'uso
- **ATTENZIONE!** Tenere tutte le viti, le piccole parti e i sacchetti di plastica fuori dalla portata dei bambini
- Identificare correttamente tutte le parti prima dell'assemblaggio
- Non utilizzare mai l'articolo se alcune parti sono rotte o mancanti
- In caso di problemi, si prega di contattare il nostro Servizio Post Vendita
- Le istruzioni del produttore devono essere sempre seguite
- Cura: Pulire con un panno morbido e asciutto. In caso di macchie più estese, strofinare accuratamente con una spugna leggermente umida e nonspugna leggermente umida e non abrasiva
- Evitare il rischio di incendio, non collocando i mobili vicino a fonti di accensione o a oggetti caldi
- Non saltare sul letto

Español

¡ IMPORTANTE ! CONSERVELO PARA FUTURAS CONSULTAS: LEA ATENTAMENTE

- Debe ser montado por un adulto. El montaje debe ser comprobado por un adulto antes del uso
- ADVERTENCIA** Mantenga todos los tornillos, piezas pequeñas y bolsas de plástico fuera del alcance de los niños.
- Identifique correctamente todas las piezas antes de montarlas
 - Nunca utilice su artículo si alguna de sus piezas está rota o falta
 - Si surge algún problema, póngase en contacto con nuestro Servicio Postventa
 - Las instrucciones del fabricante deben seguirse en todo momento
 - Cuidado: Limpiar con un paño suave y seco. En caso de manchas más grandes, frote cuidadosamente con una esponja no abrasiva ligeramente humedecida.
 - Evite el riesgo de incendio no colocando los muebles cerca de fuentes de ignición u objetos calientes.
 - No saltar sobre la cama.

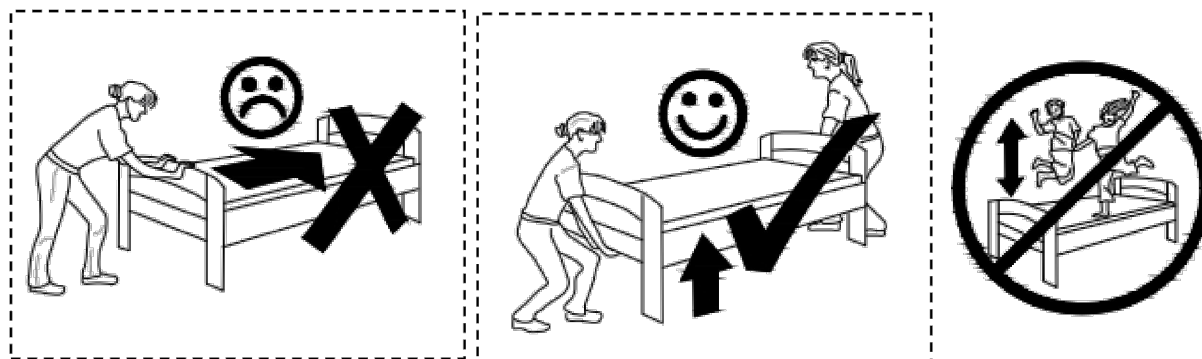

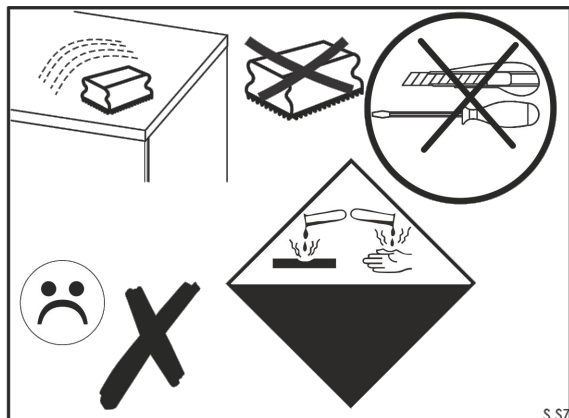
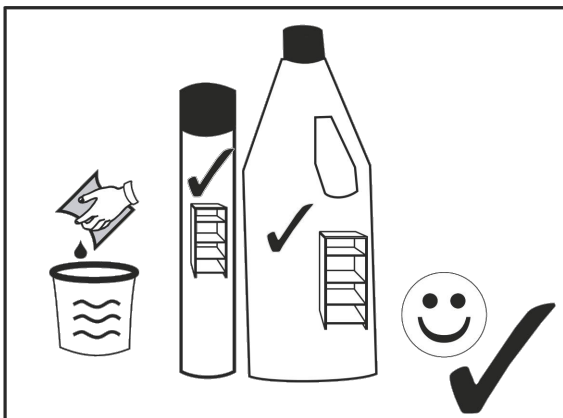
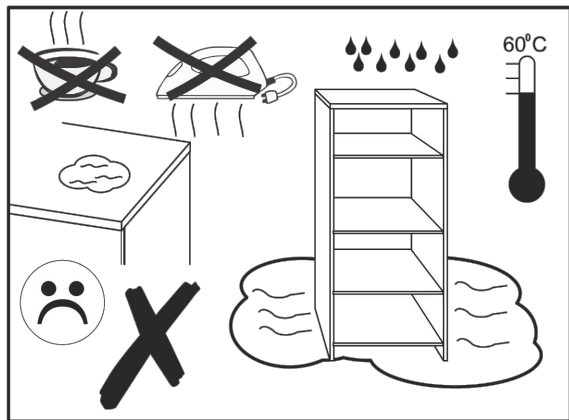
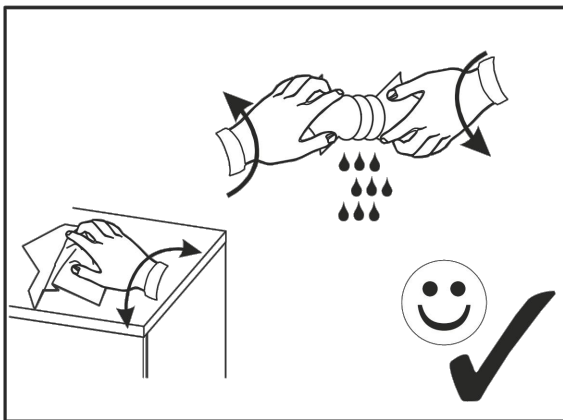
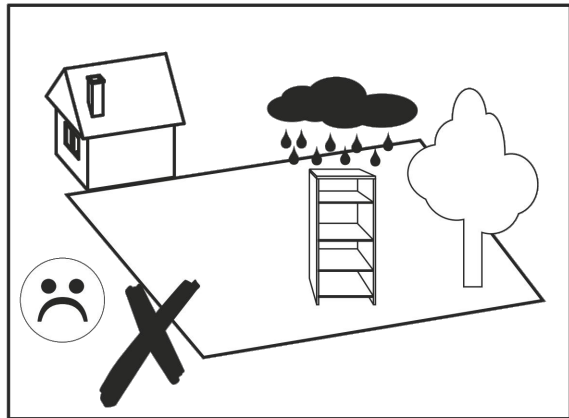
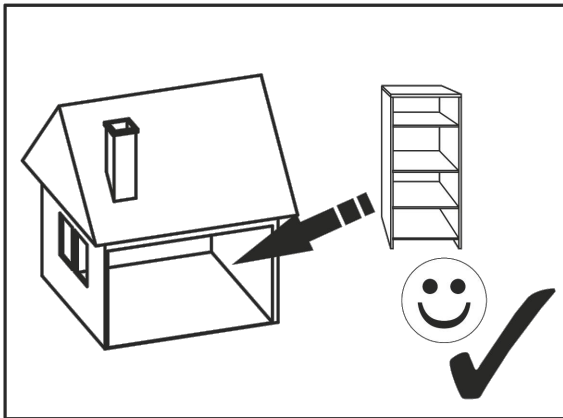

S.57

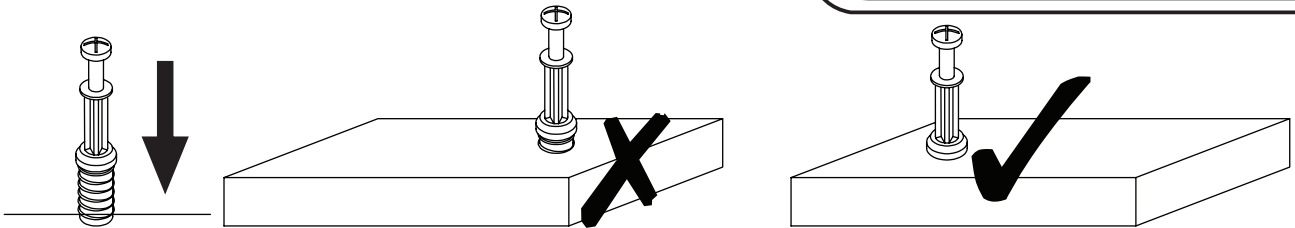

EN_QUICKFIT: Tighten quickfit until shoulder is flush with panel. Do not overtighten or undertighten.

FR_RACCORD RAPIDE: Faites serrer le raccord rapide jusqu'à ce que l'épaulement soit parfaitement encastré dans le panneau. Il ne faut ni trop serrer ni insuffisamment serrer.

ES_QUICKFIT: Apriete quickfit hasta que el hombro se descargue con el panel. NO lo sobreapriete ni lo apriete poco.

DE_QUICKFIT: Ziehen Sie den Quickfit fest, bis die Schulter mit der Platte bündig ist. Bitte nicht zu fest oder zu schwach anziehen.

IT_MONTAGGIO RAPIDO: Stringere il montaggio rapido fino a quando la spalla è a filo con il pannello, non stringere troppo o troppo poco.

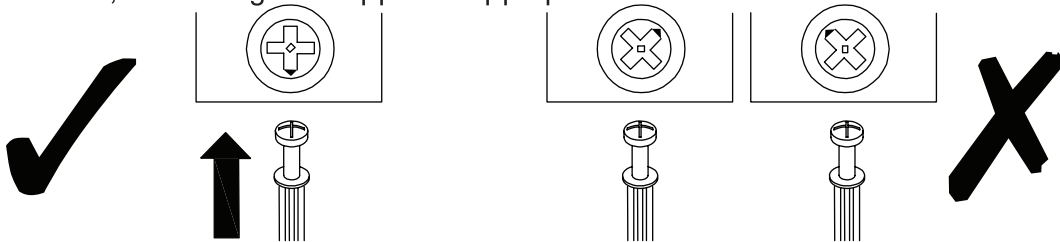

EN_CAM LOCK: When fitting cam lock, ensure starting position is correct before you insert connecting quickfit.

FR_SERRURE BATTEUSE: Avant d'insérer la serrure batteuse, veillez à la bonne orientation avant d'insérer le raccord rapide.

ES_CIERRE DE LA CÁMARA: Cuando instale el cierre de la cámara, asegúrese de que la posición de inicio es correcta antes de que inserte el quickfit conector.

DE_CAM-LOCK: Achten Sie bei der Montage des Cam-Locks auf die richtige Ausgangsposition, bevor Sie den Quickfit einsetzen.

IT_BLOCCAGGIO A CAMMA: Quando si monta il bloccaggio a camma, assicurarsi che la posizione iniziale sia corretta prima di inserire il montaggio rapido di collegamento.

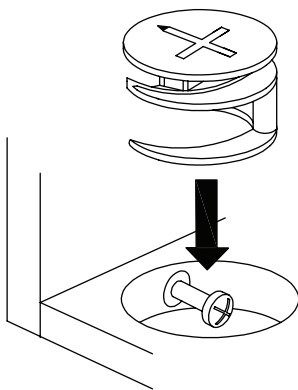

EN_Quickfit head should be in the centre of the cam lock when the two panels are joined.

Cam lock should be inserted before quickfit.

FR_Lorsque les deux panneaux sont assemblés, la tête du raccord rapide doit reposer au centre de la serrure batteuse. Il faut insérer la serrure batteuse avant le raccord rapide.

ES_El cabezal del quickfit debe estar en el centro del cierre de la cámara cuando se unan los dos paneles.

Se debe insertar el cierre de la cámara antes que el quickfit.

DE_Der Quickfit-Kopf sollte sich in der Mitte des Cam-Locks befinden, wenn die beiden Platten zusammengefügt sind. Der Cam-Lock sollte vor dem Quickfit eingesetzt werden.

IT_La testa del montaggio rapido deve trovarsi al centro del bloccaggio a camma quando i due pannelli sono uniti.

Il Bloccaggio a Camma deve essere inserito prima del montaggio rapido.

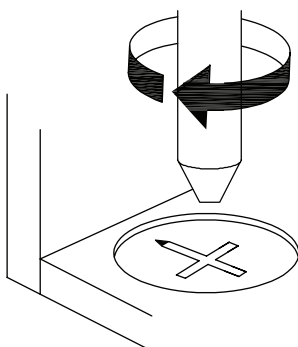

EN_Turn cam lock clockwise to tighten.

FR_Faites tourner la serrure batteuse dans le sens des aiguilles d'une montre pour la resserrer.

ES_Gire el cierre de la cámara en sentido horario para apretarlo.

DE_Drehen Sie den Cam-Lock im Uhrzeigersinn, um ihn festzuziehen.

IT_Ruotare il bloccaggio a camma in senso orario per stringere.

GETTING TO KNOW YOUR PRODUCT

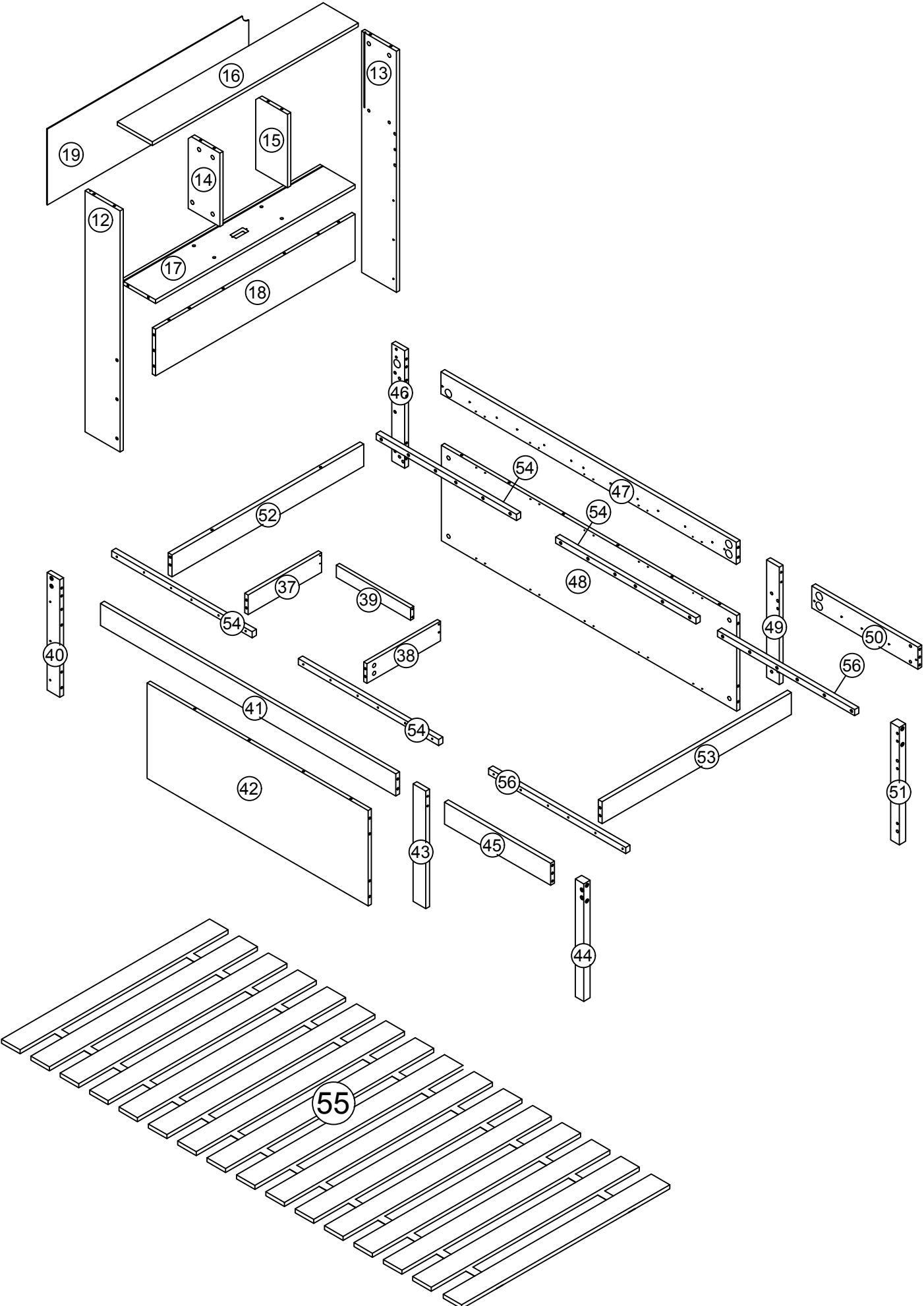

GETTING TO KNOW YOUR PRODUCT

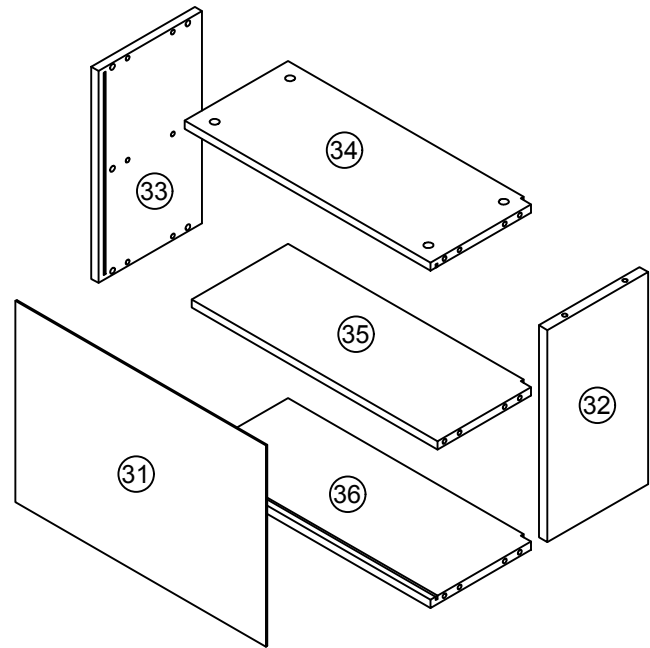
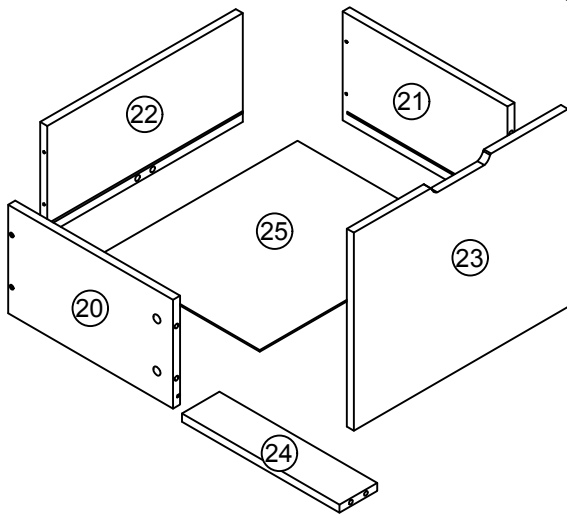
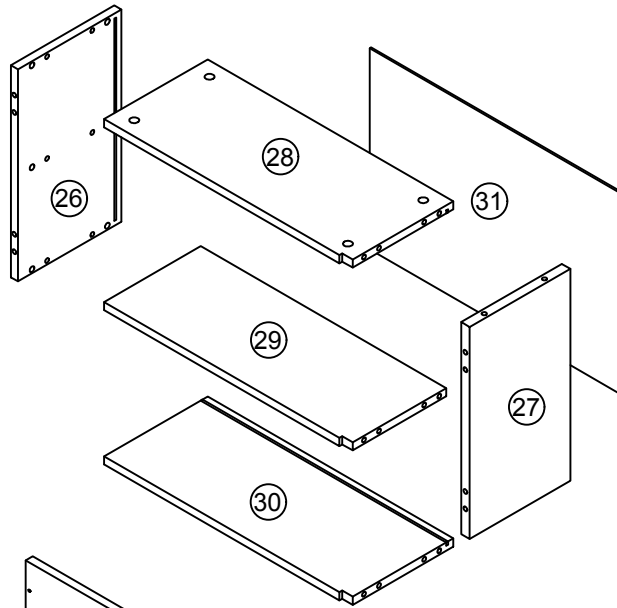
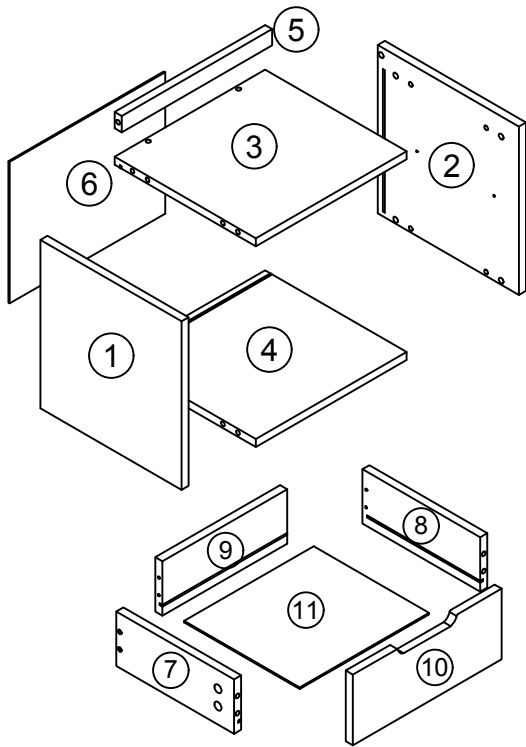

Part List/Teileliste/Liste des pieces

N616P390108W

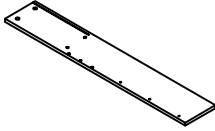
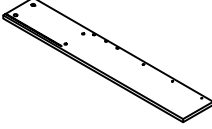
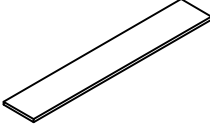
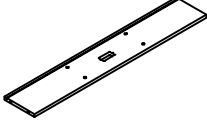
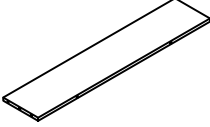
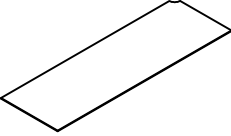
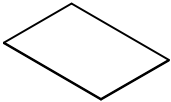
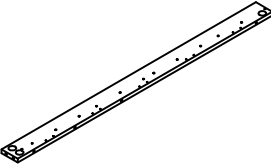
12		1
13		1
16		1
17		1
18		1
19		1
31		2
41		1

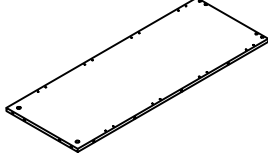
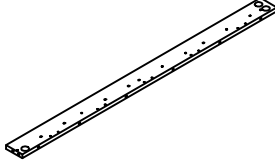
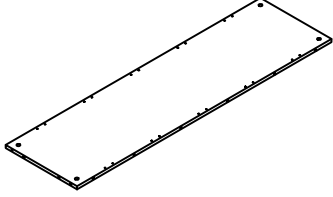
42		1
47		1
48		1

Part List/Teileliste/Liste des pieces

N616P390109W

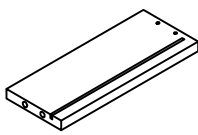
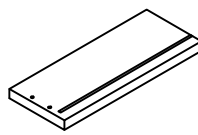
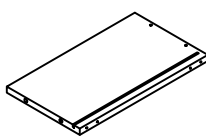
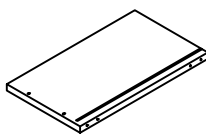
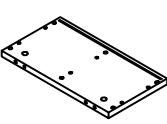
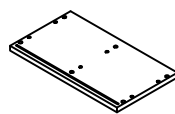
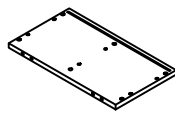
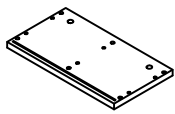
7		1
8		1
20		1
21		1
26		1
27		1
32		1
33		1

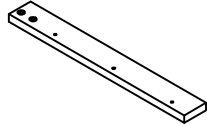
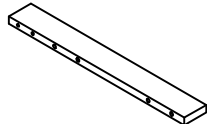
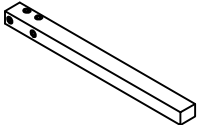
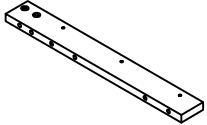
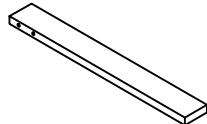
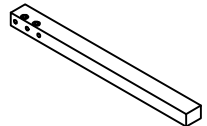
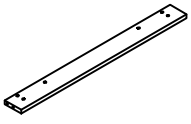
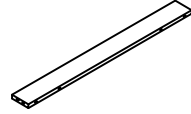
40		1
43		1
44		1
46		1
49		1
51		1
52		1
53		1

Part List/Teileliste/Liste des pieces N616P390109W

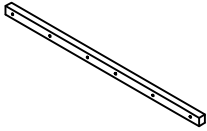
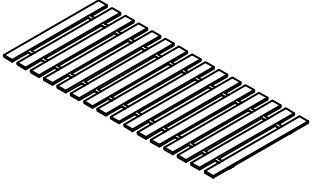
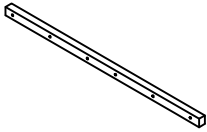
54		4
55		1
56		2

Part List/Teileliste/Liste des pieces

N616P390110W

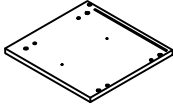
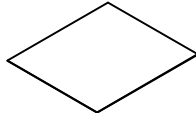
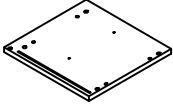
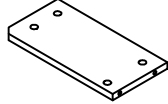
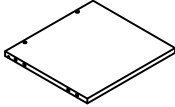
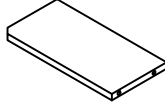
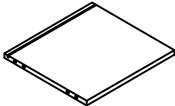
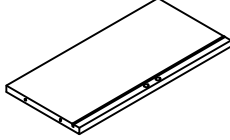
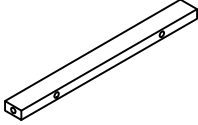
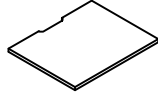
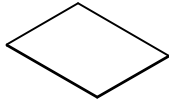
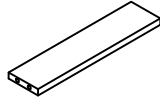
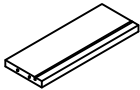
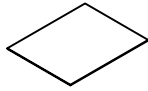
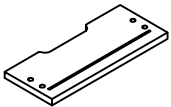
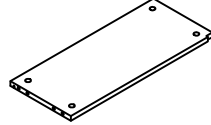
①		1	⑪		1
②		1	⑭		1
③		1	⑮		1
④		1	⑳		1
⑤		1	㉓		1
⑥		1	㉔		1
⑨		1	㉕		1
⑩		1	㉘		1

Part List/Teileliste/Liste des pieces



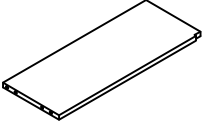
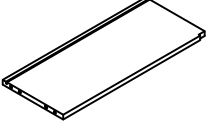
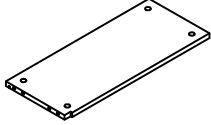
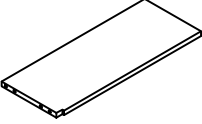
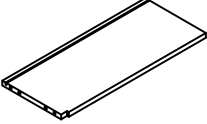
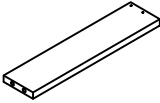
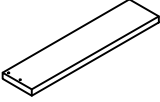
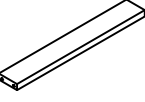

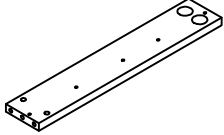
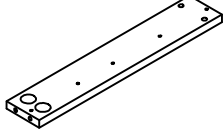
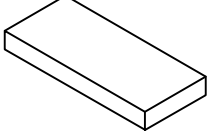





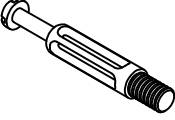
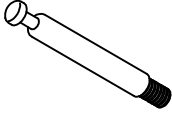



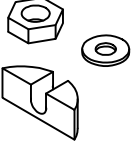
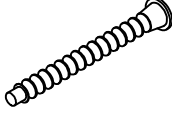
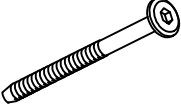
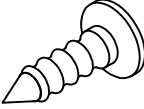
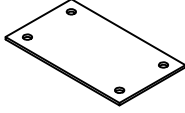

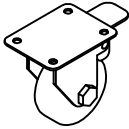
N616P390110W

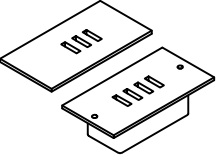
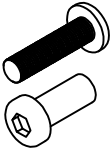
(29)		1
(30)		1
(34)		1
(35)		1
(36)		1
(37)		1
(38)		1
(39)		1

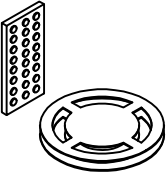
(45)		1
(50)		1
 Hardware kit		

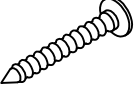
Hardware List/ Hardware-Liste/Liste du matériel

N616P390110W

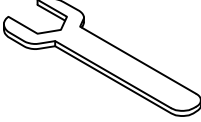
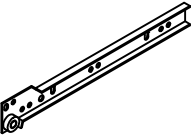
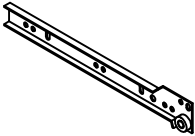
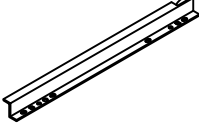
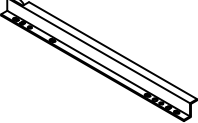
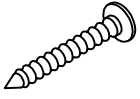
	 Ø6*60mm		 Ø8*30	 Ø8*40
A*82	B*8	C*90	D*2	E*68
	 Ø5*40	 M6*90mm	 Ø3.5*14	
F*12	G*4	H*12	J*86	K*11
				
L*20	M*2	N*2	P*4	Q*1
 M6*14-M6*20	 Ø6*140	 Ø6*80		
R*6	S*4	T*2	U*1	V*12
 Ø4*30				
W*44	X*12	Y*102	Z*2	AA*2
				 Ø3*30
CL*1	CR*1	DL*1	DR*1	BB*32

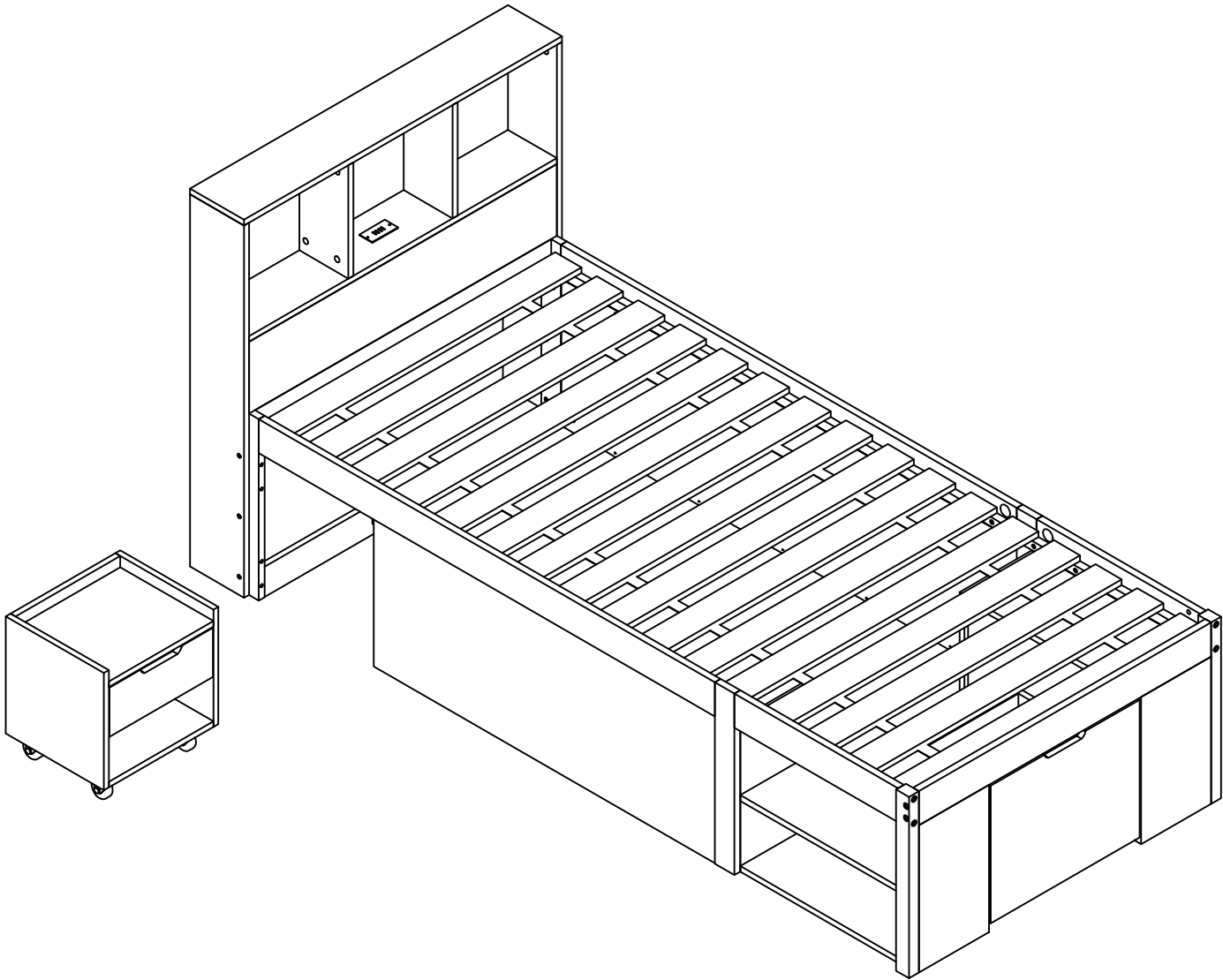

L : 14-43 PAGES

1



A x 14

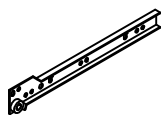

CL x 1

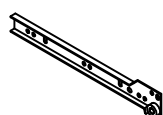

CR x 1

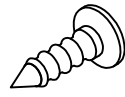

J x 4

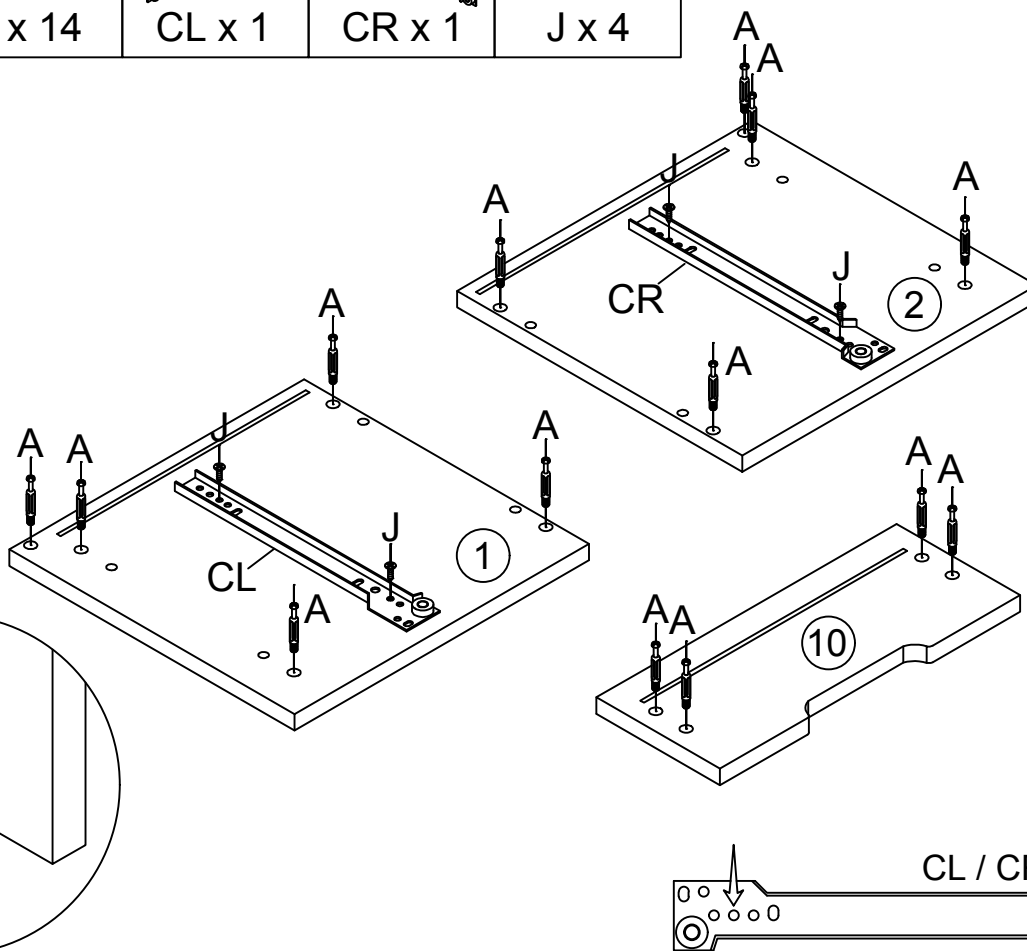

2

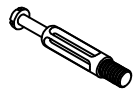

A x 16

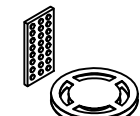

U x 1

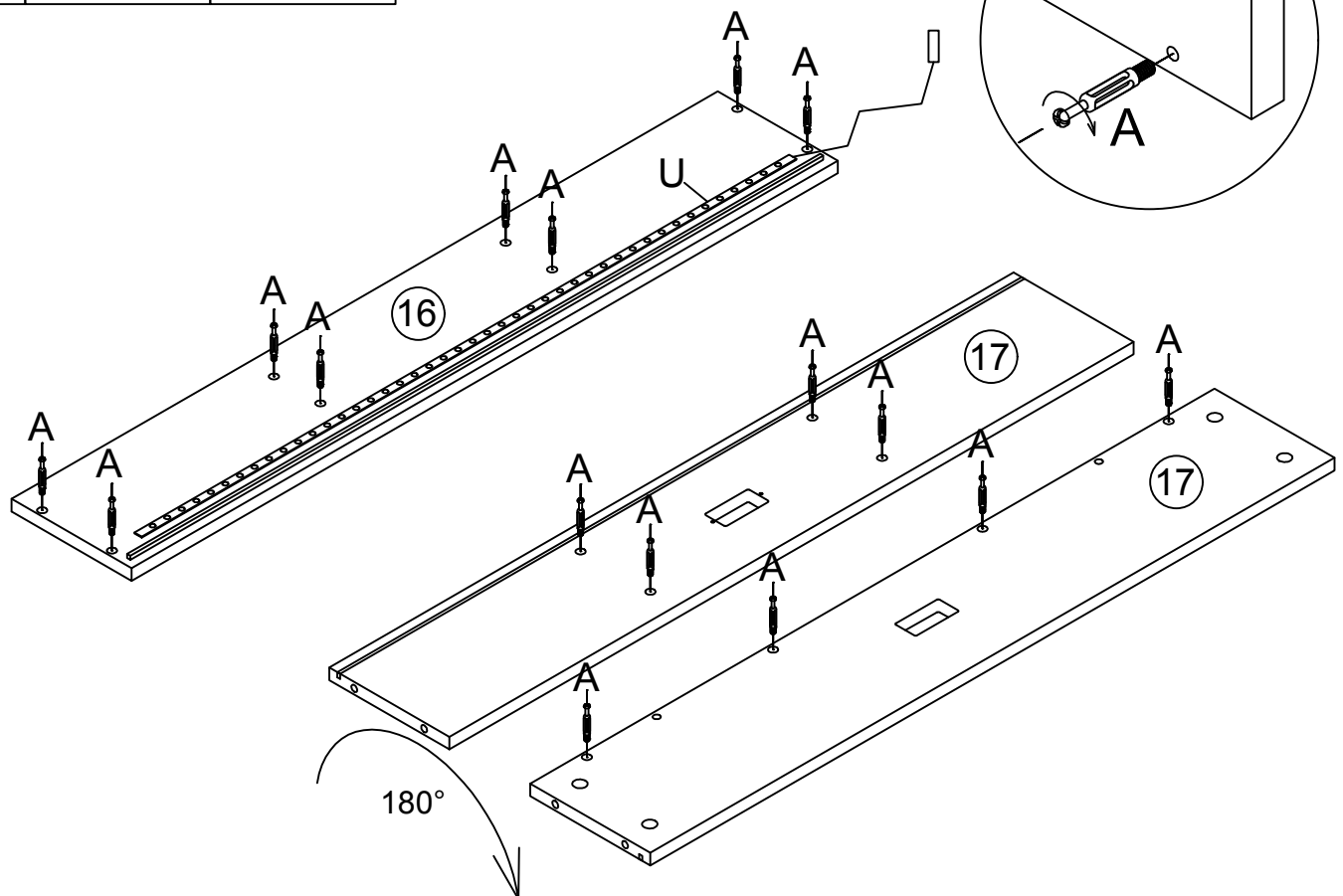

3



A x 8

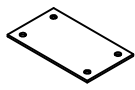

K x 2

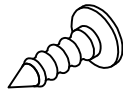

J x 4

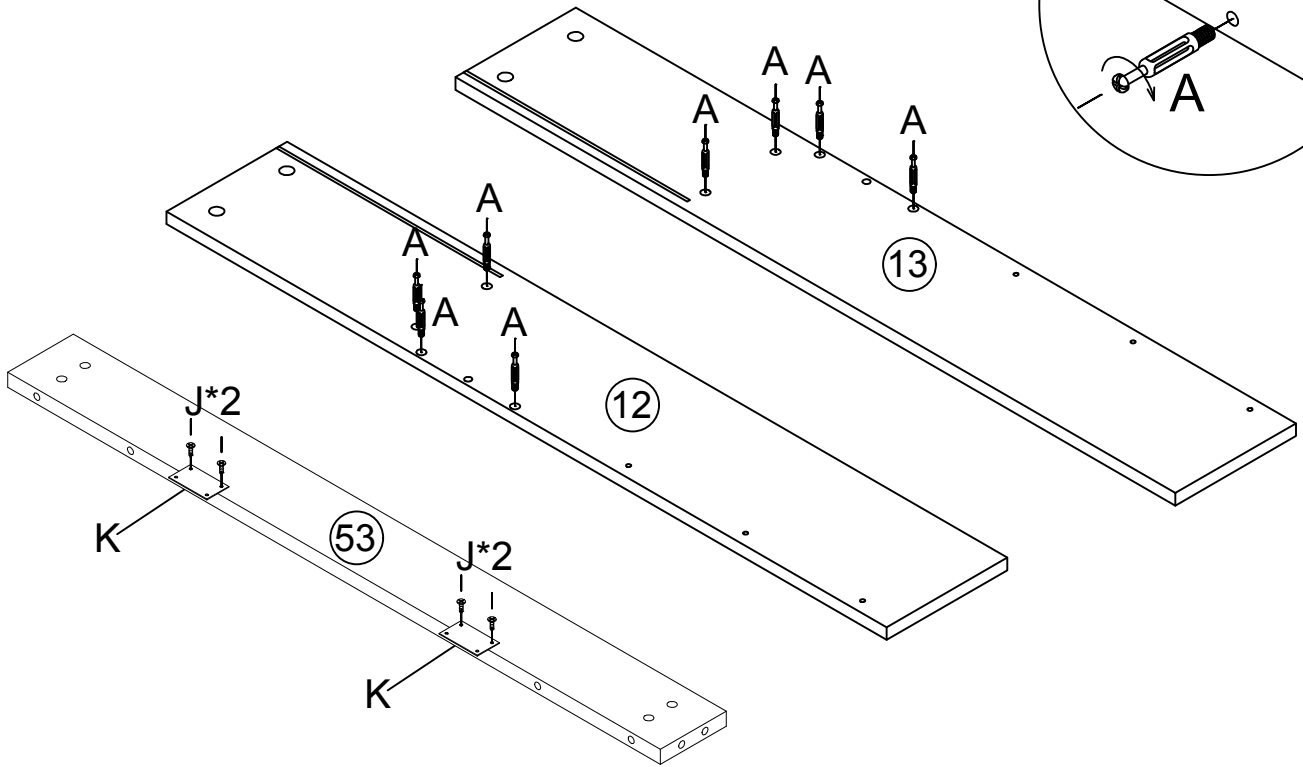
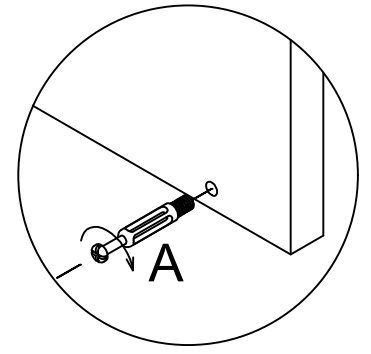

4

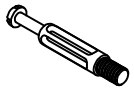

A x 24

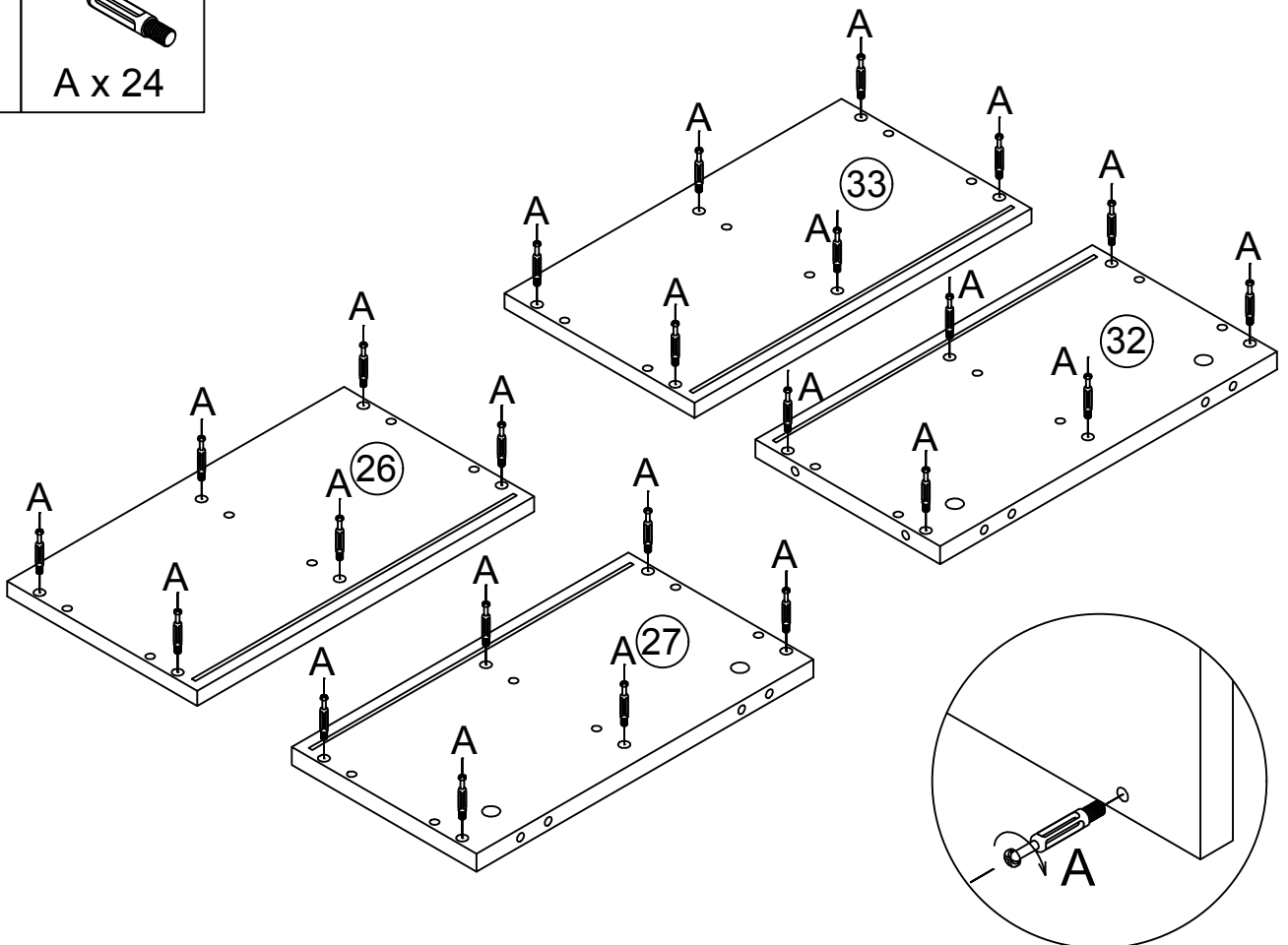

5

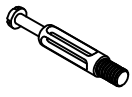

A x 12

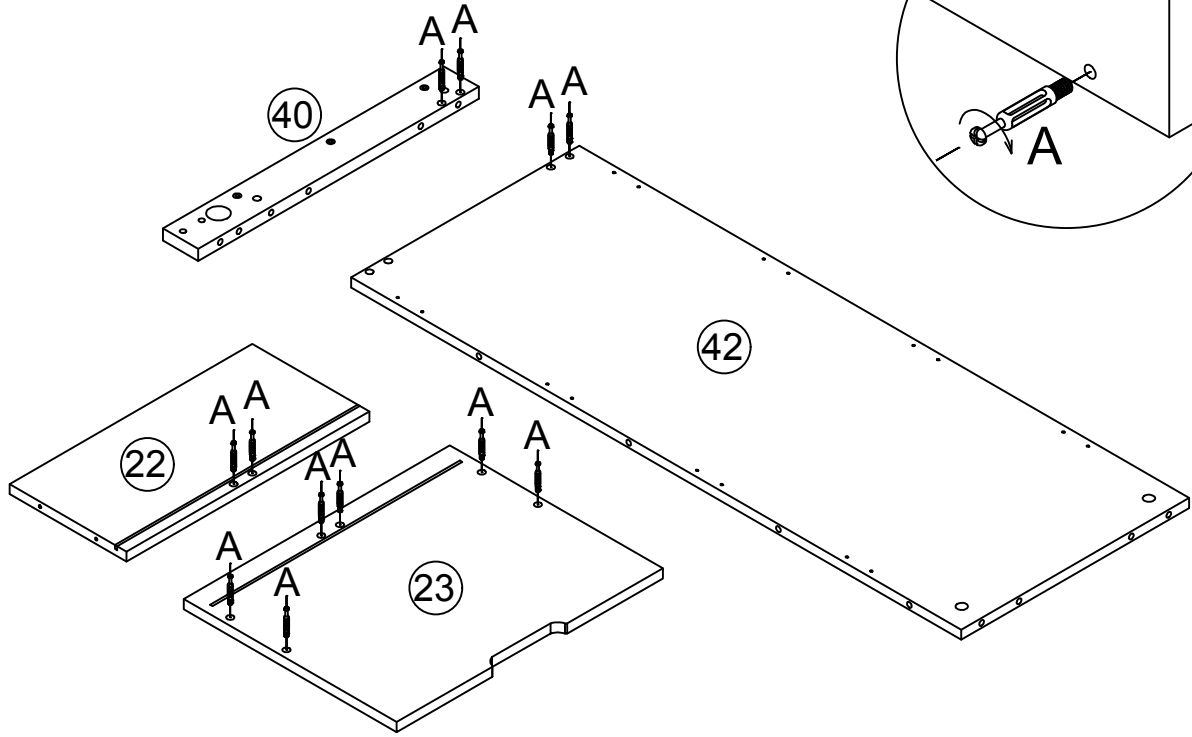

6

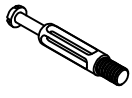

A x 8

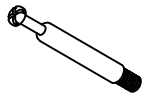

B x 8



L x 8

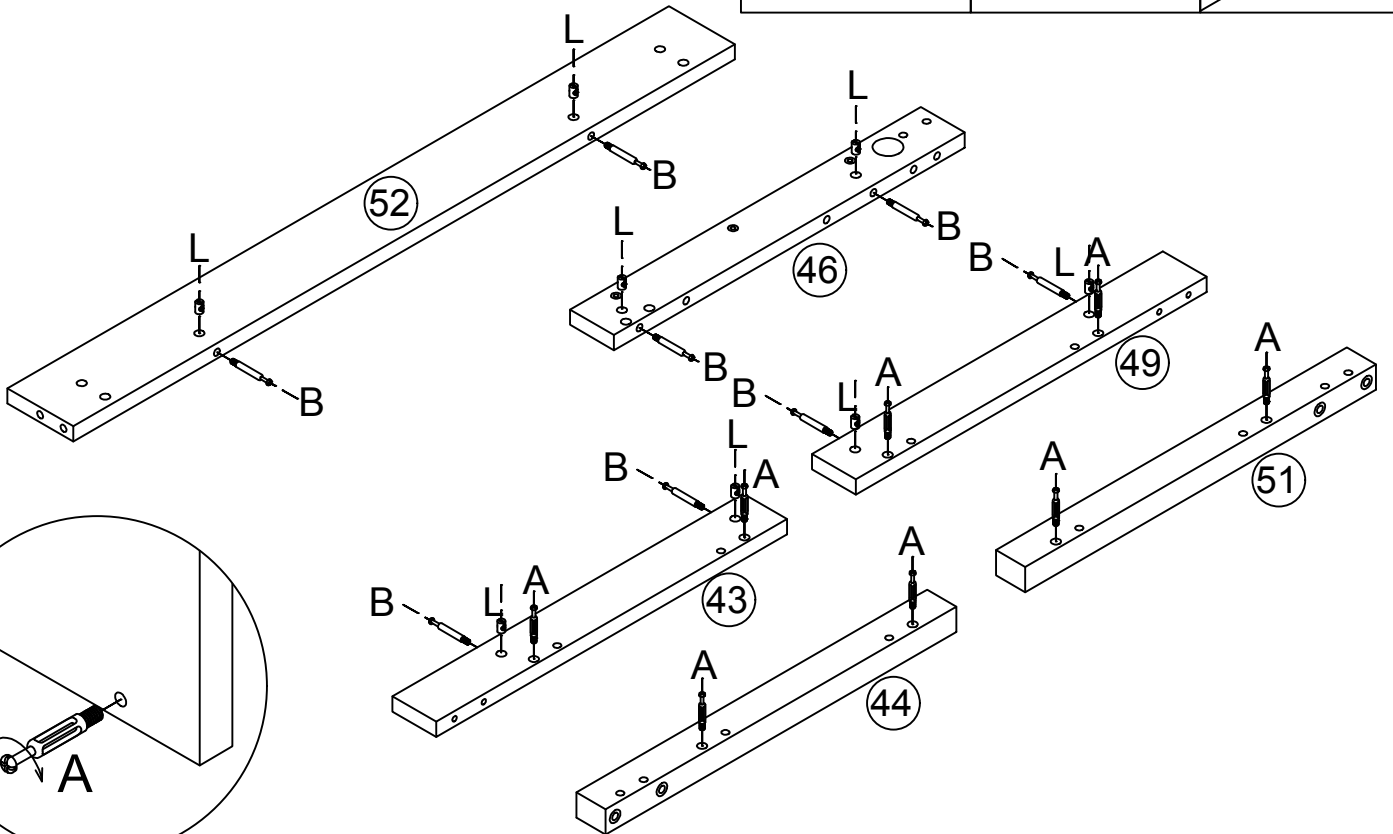
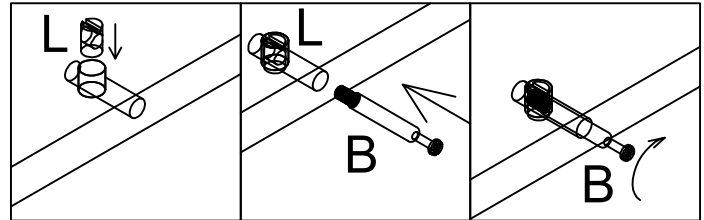

7

D x 2

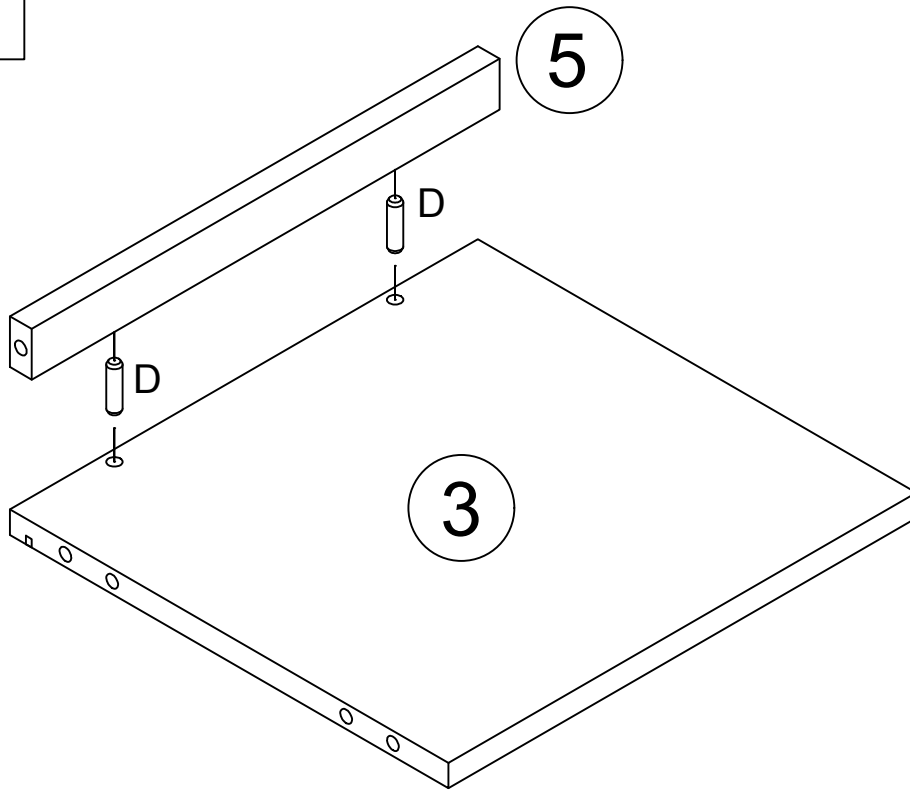

8



E x 4

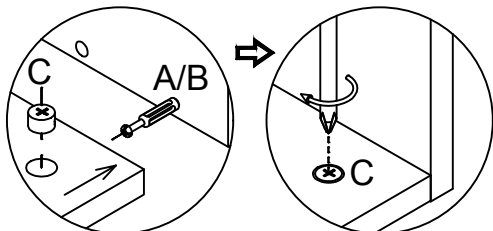
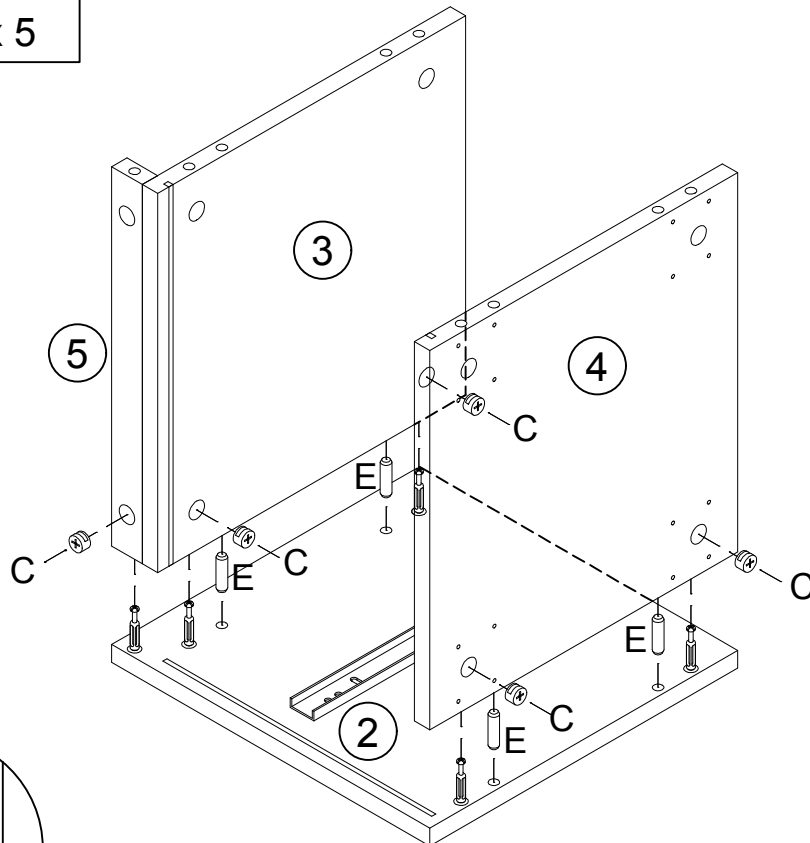

C x 5

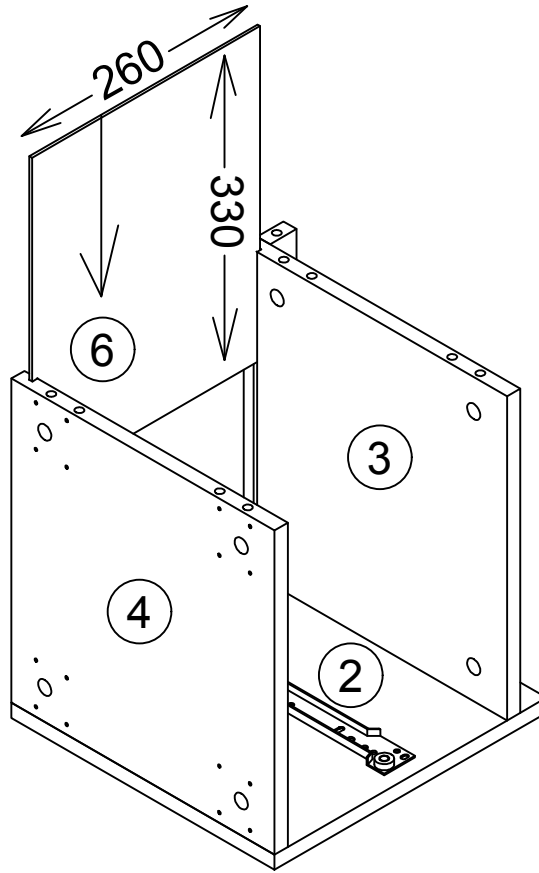

9



10

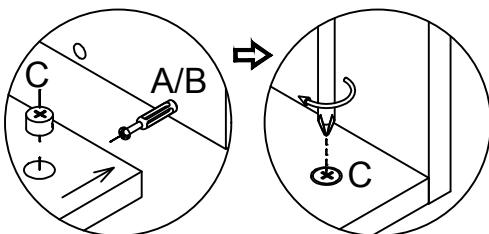
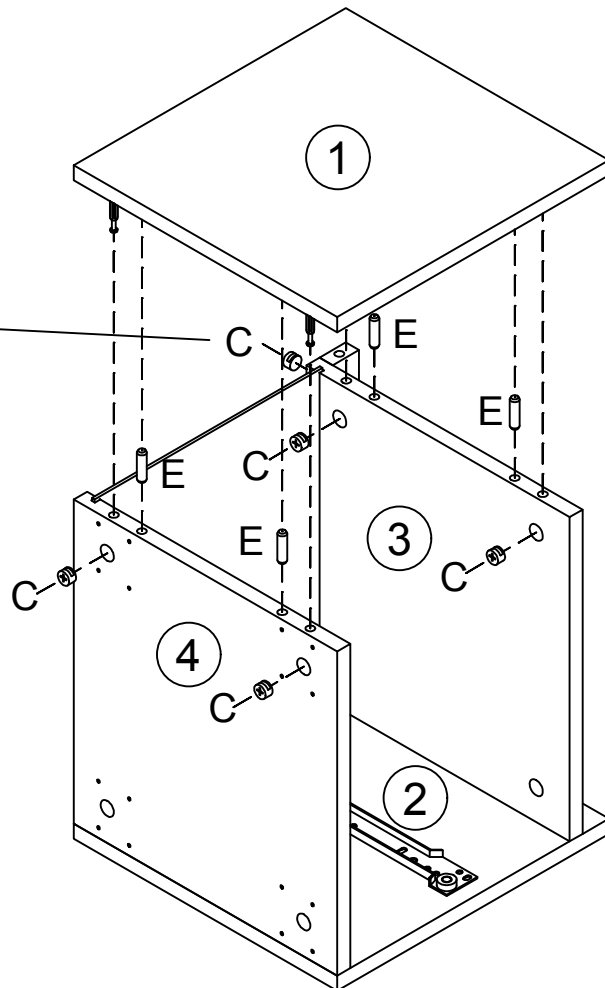
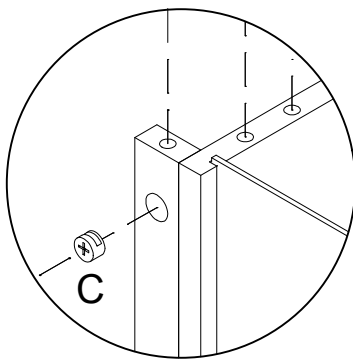
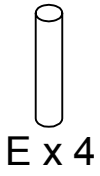

11



M x 2



N x 2

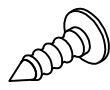

J x 16

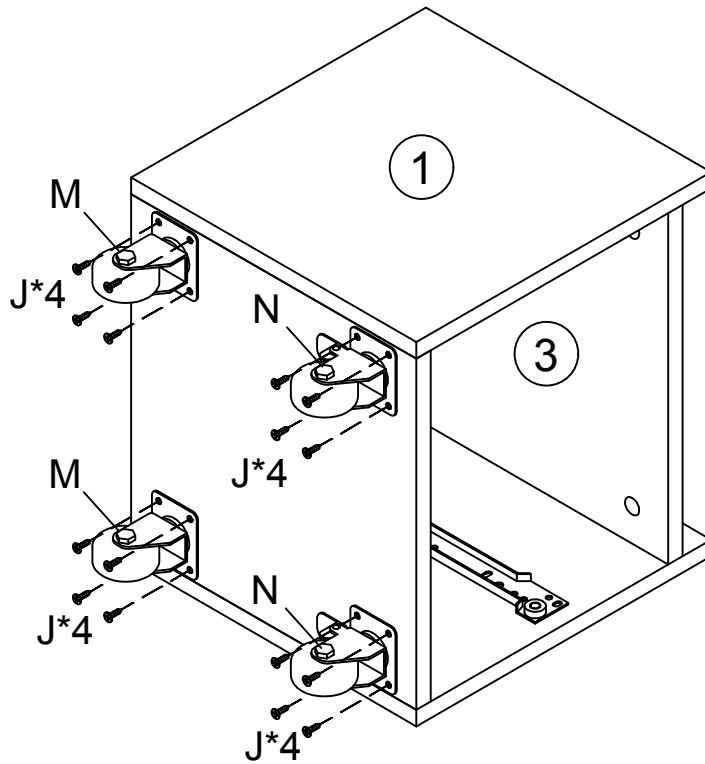

12



W x 4

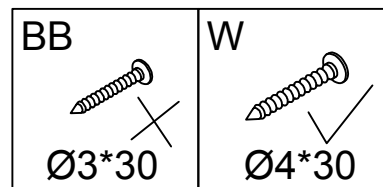
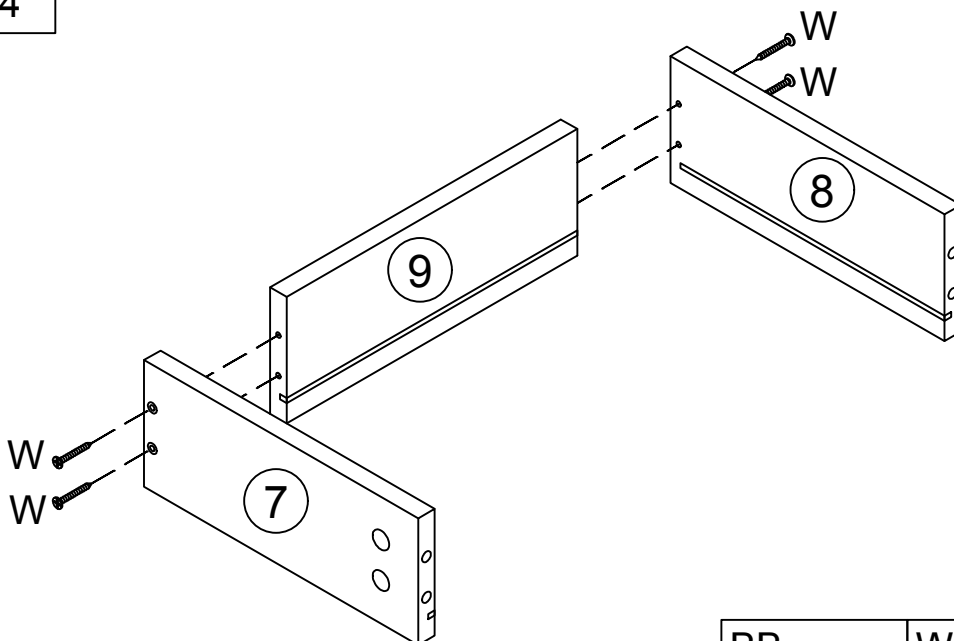

13



C x 4

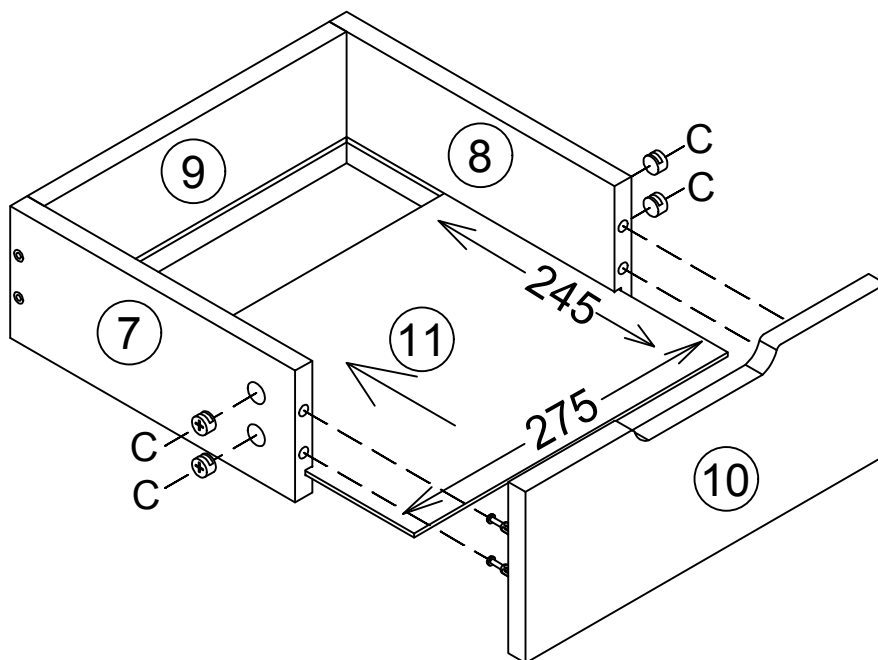
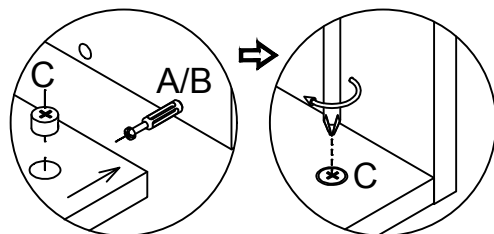

14

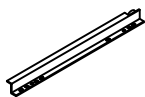

DL x 1

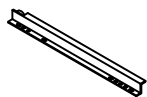

DR x 1

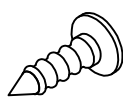

J x 4

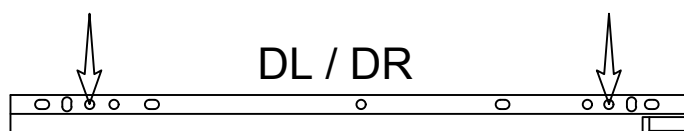
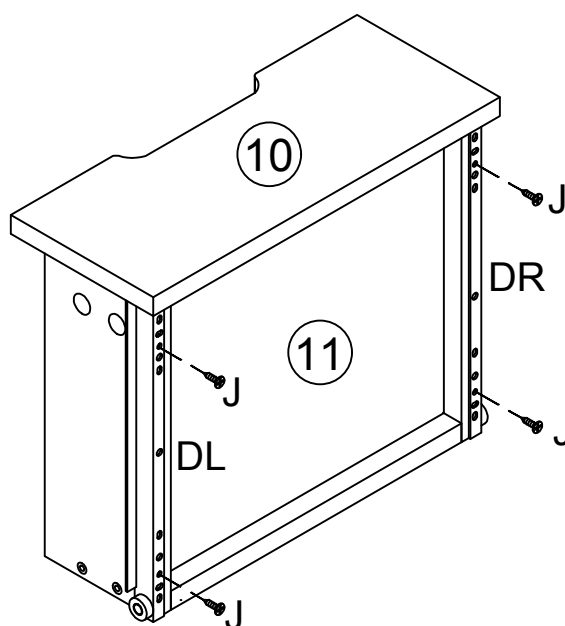

15

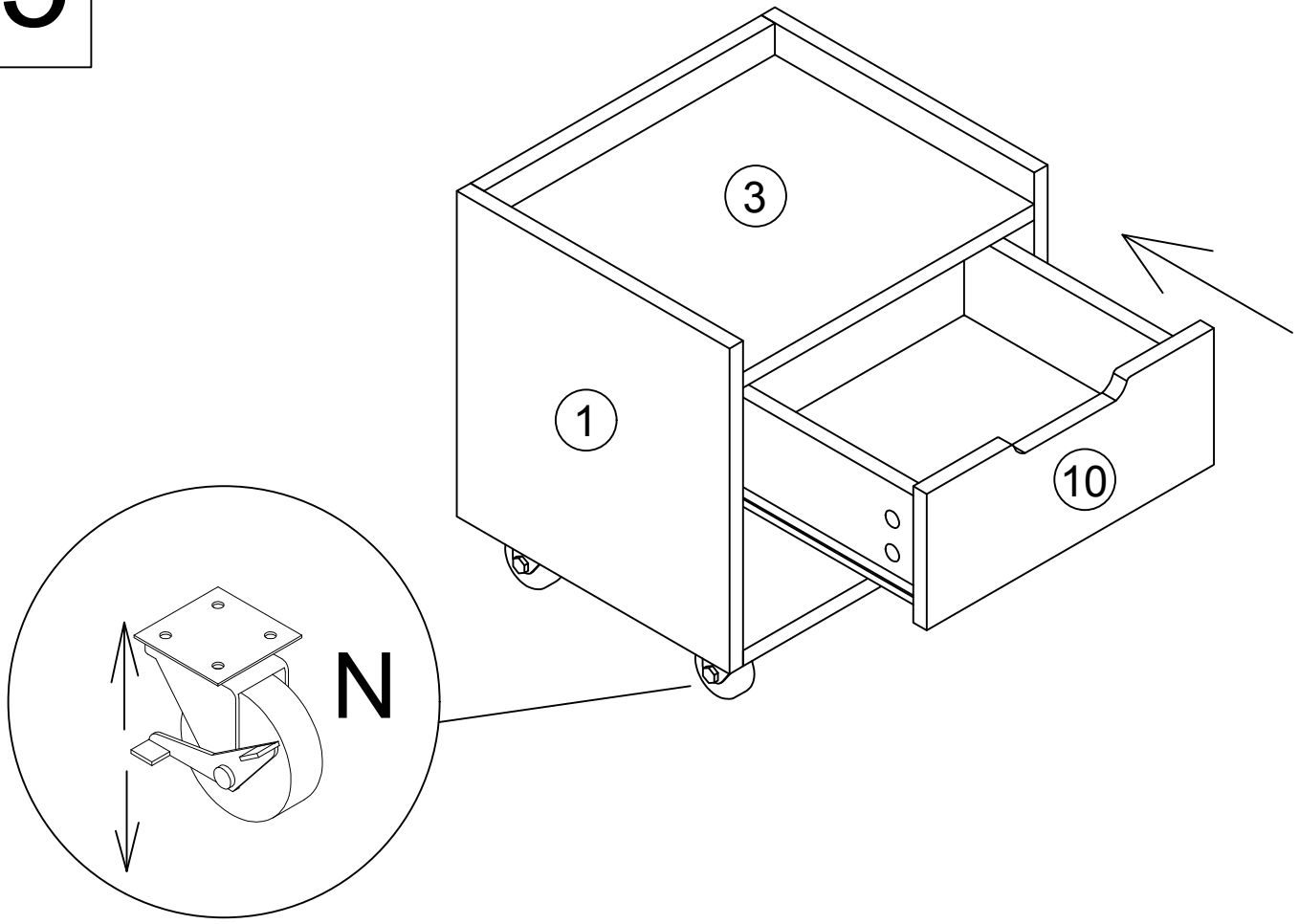

16



V x 4

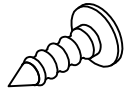

J x 4

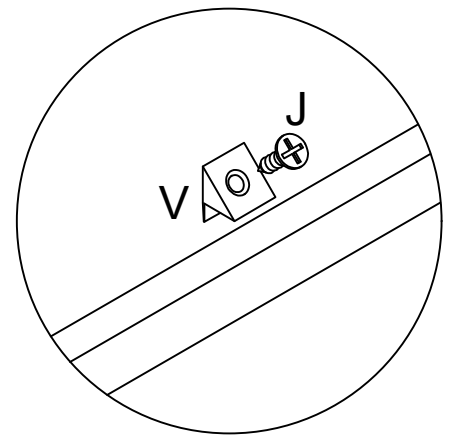
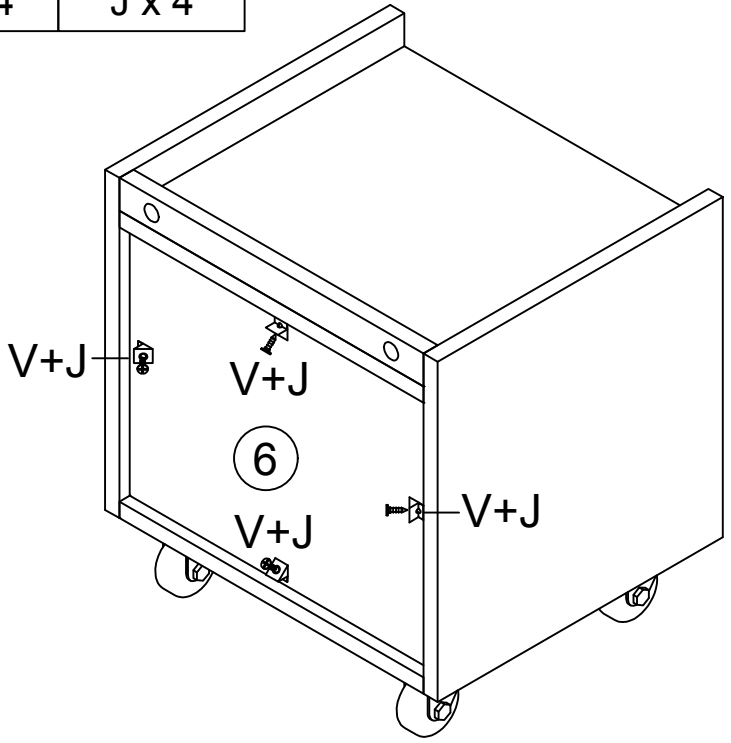

17



C x 4

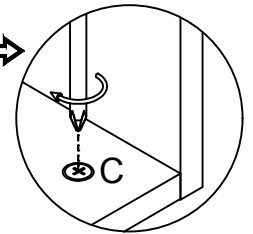
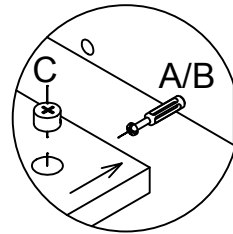
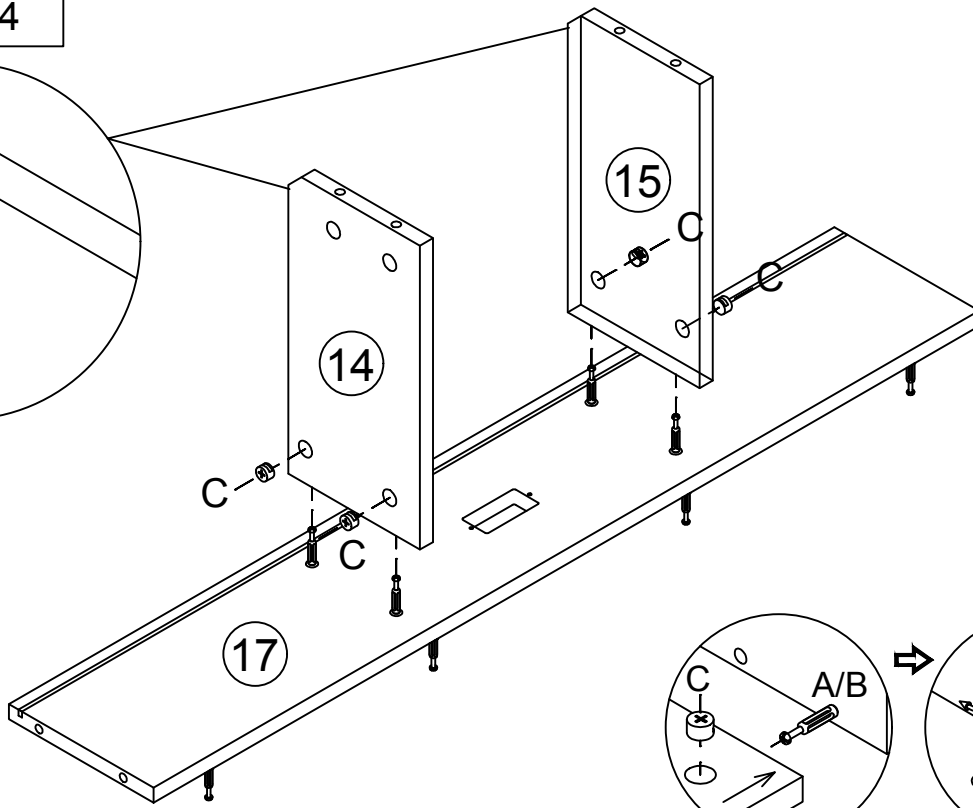
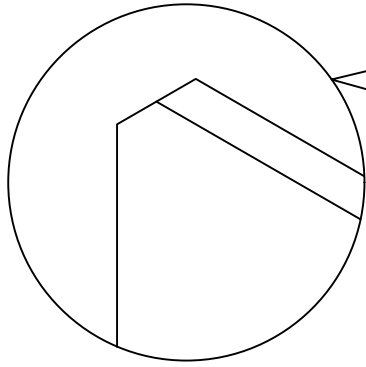

18



E x 2



C x 4

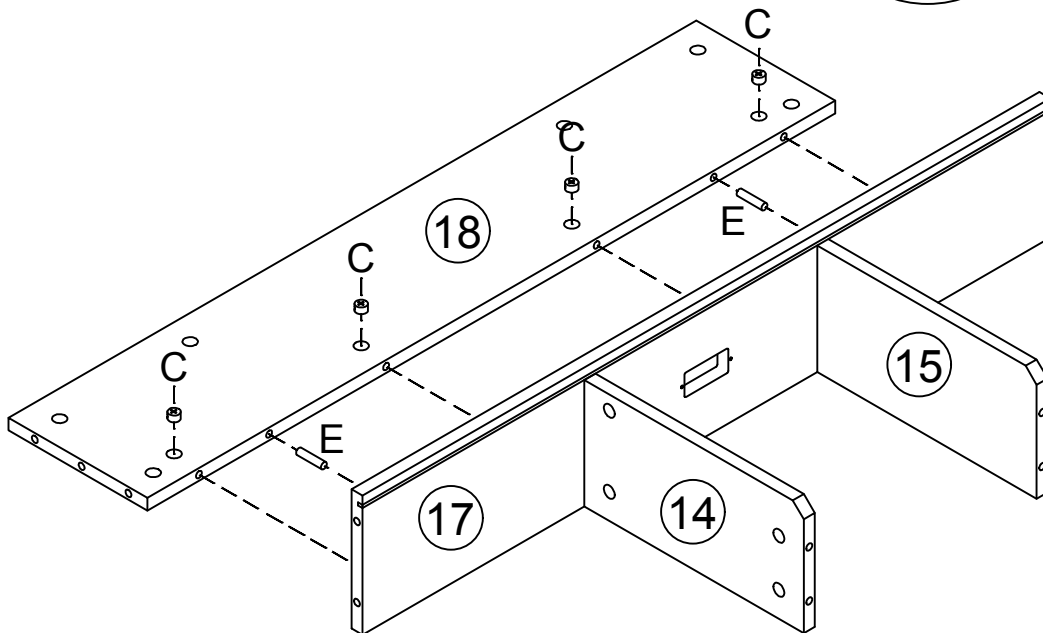
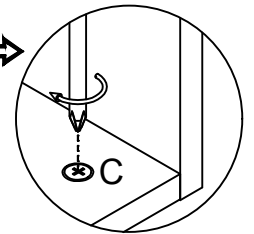
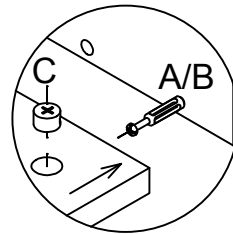

19

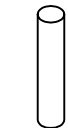

E x 2



C x 8

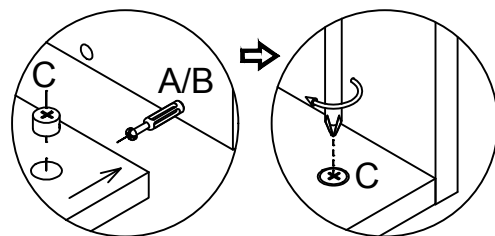
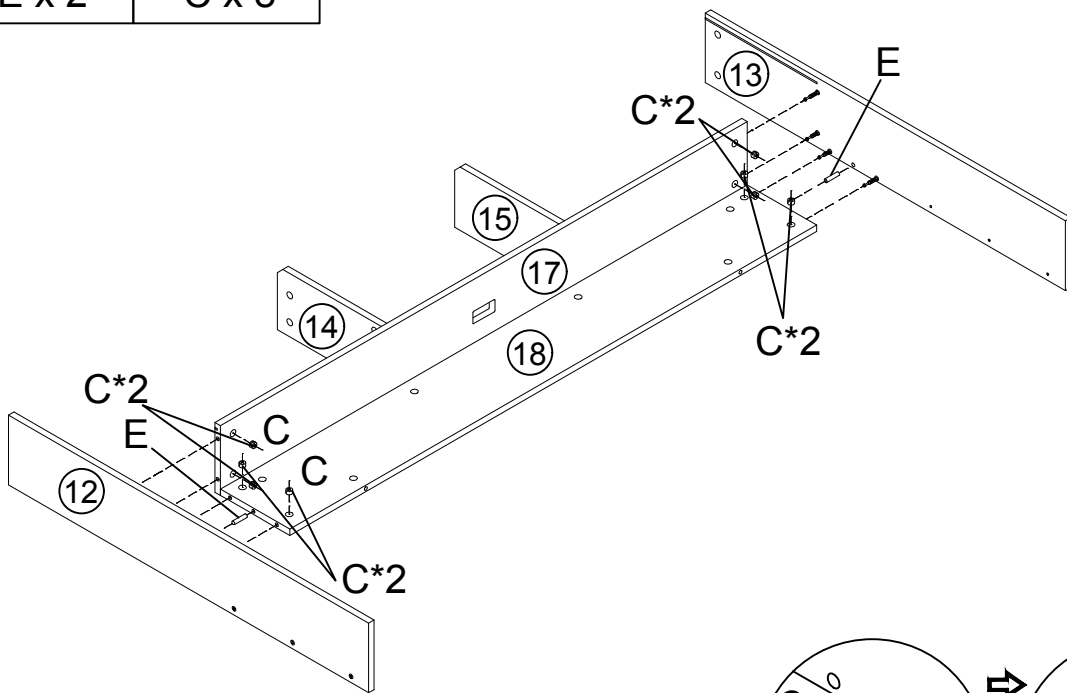

20

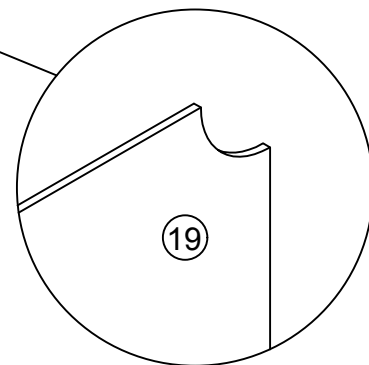
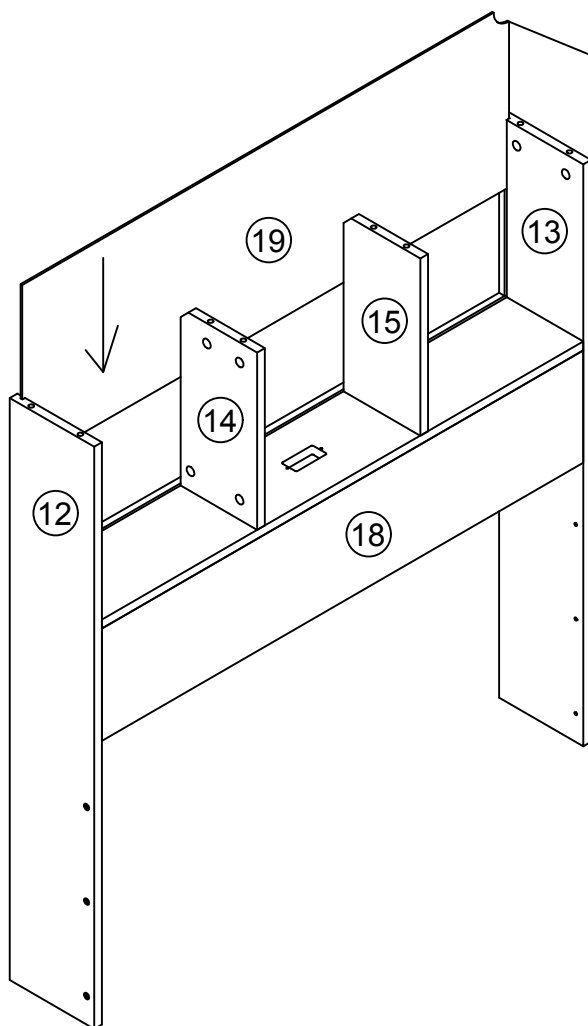

21



C x 8

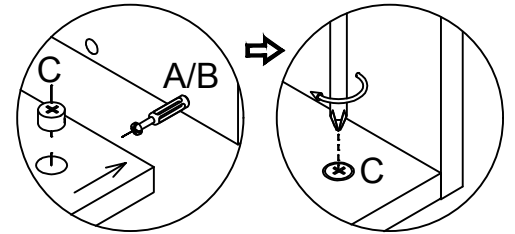
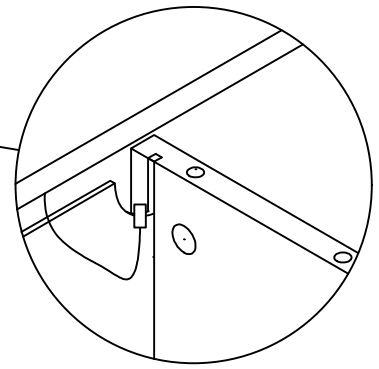
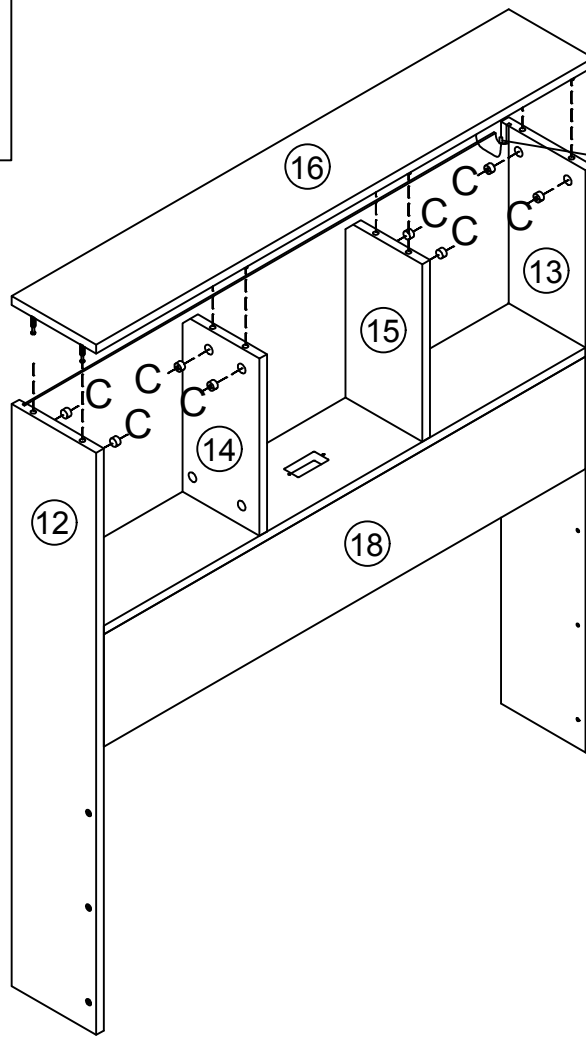

22



C x 2

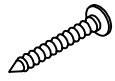

W x 4

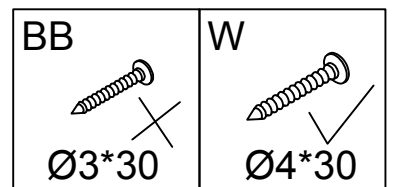
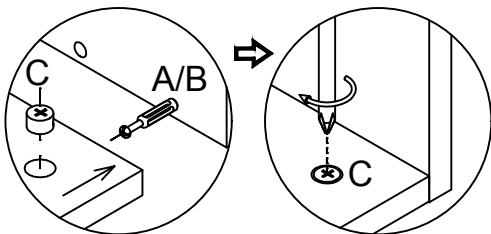
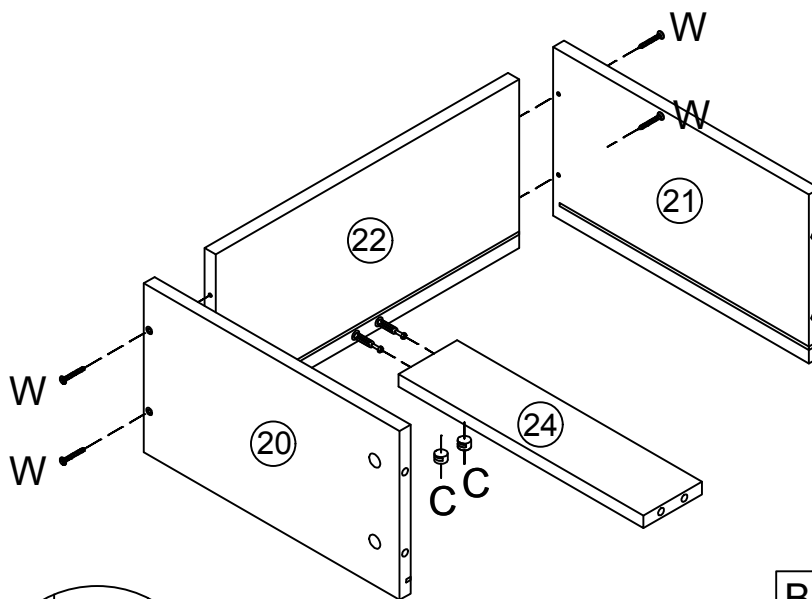

23

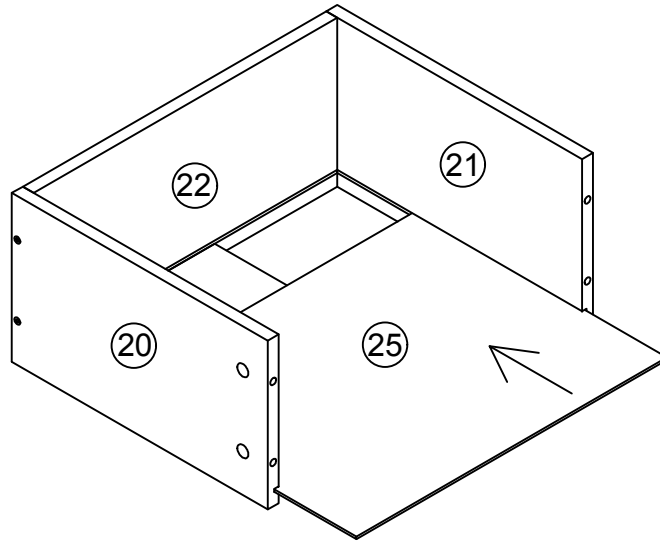

24



C x 6

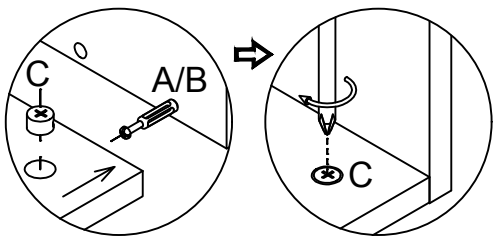
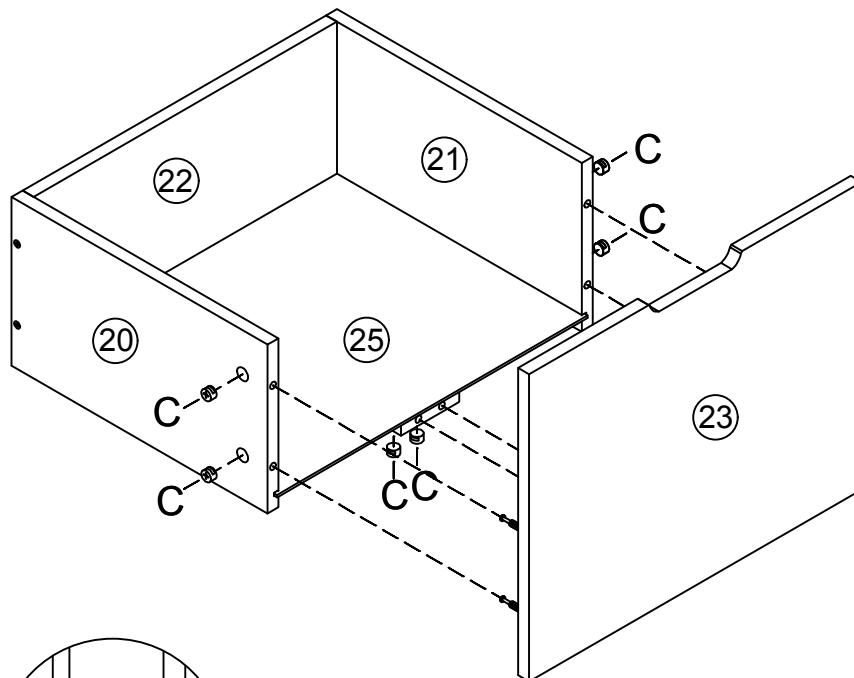

25

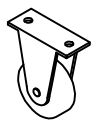

P x 4

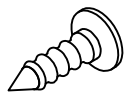

J x 8

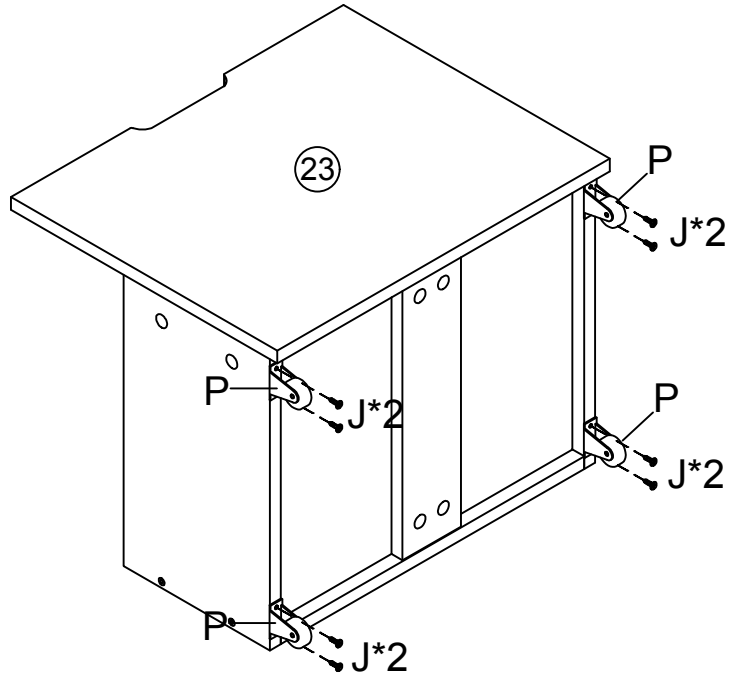

26



E x 6



C x 6

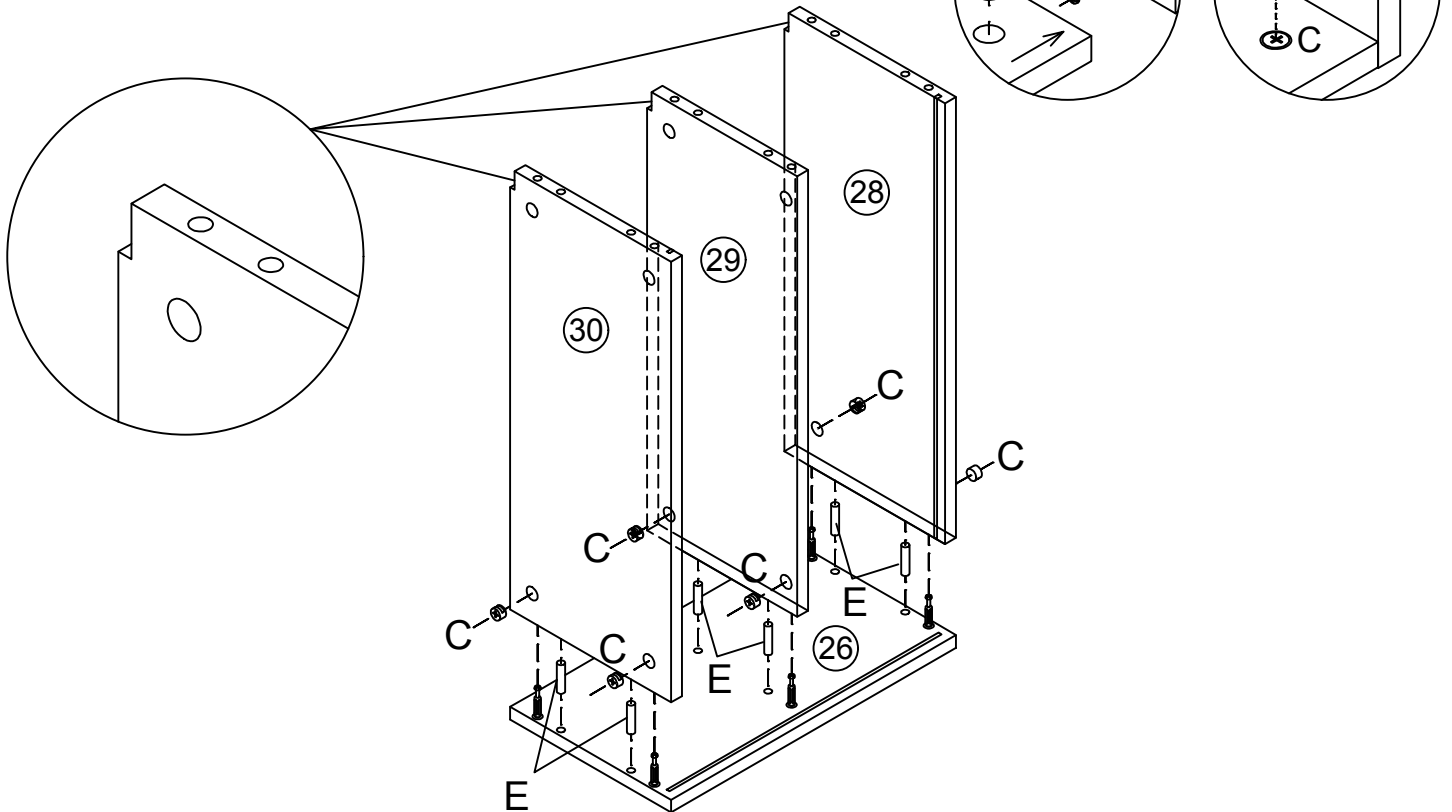

27

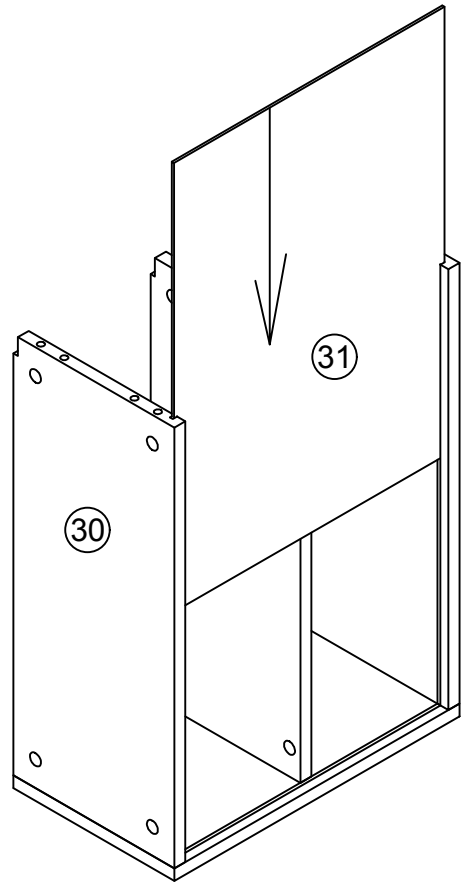

28

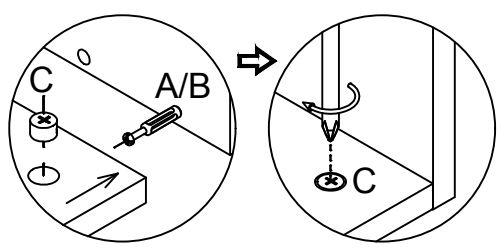
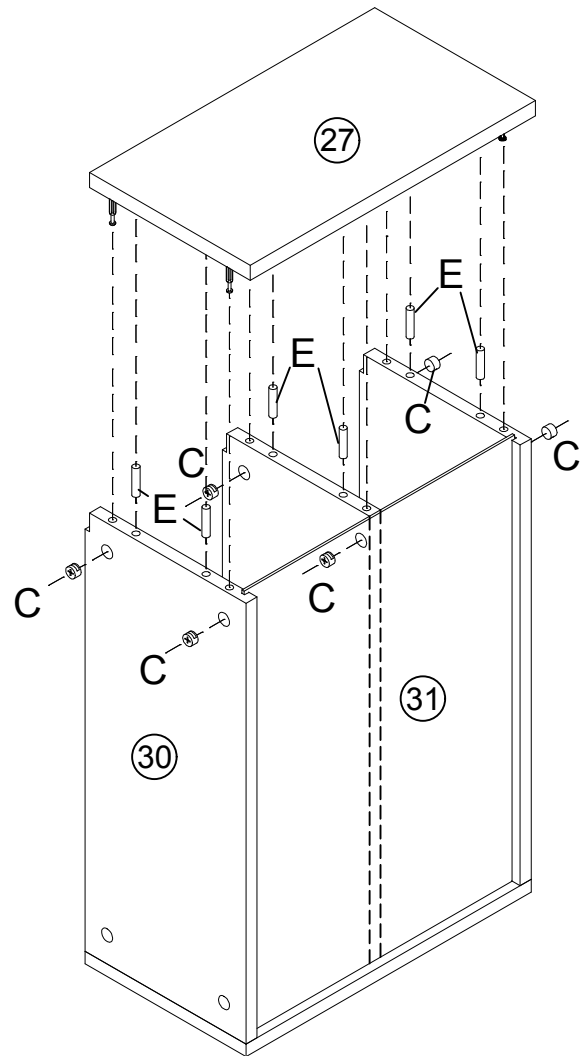

29



V x 4

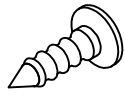

J x 4

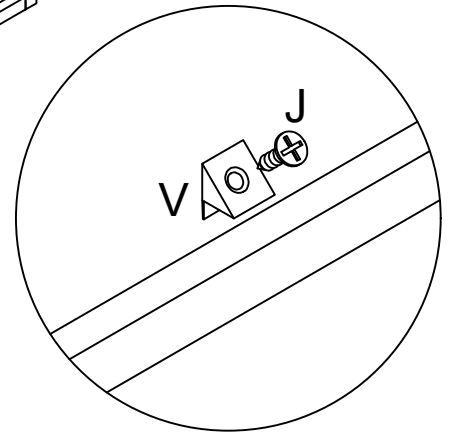
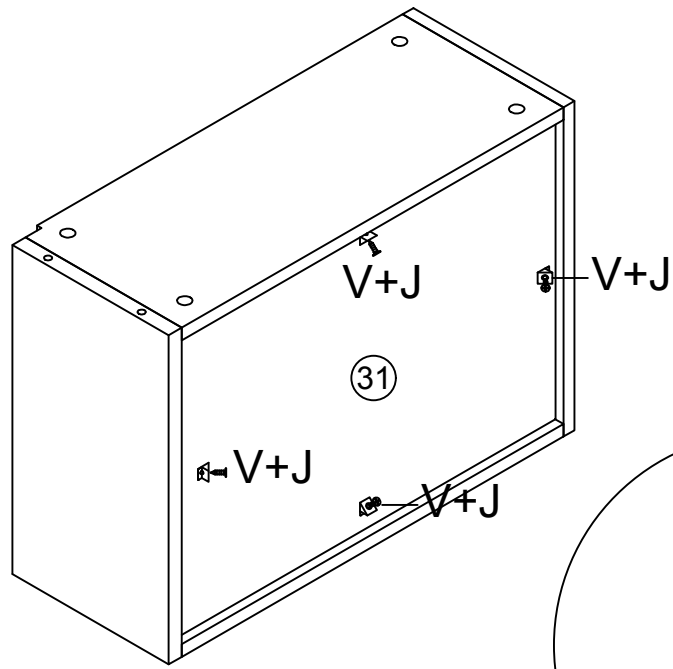

30



E x 6



C x 6

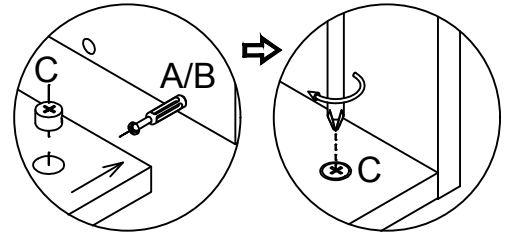
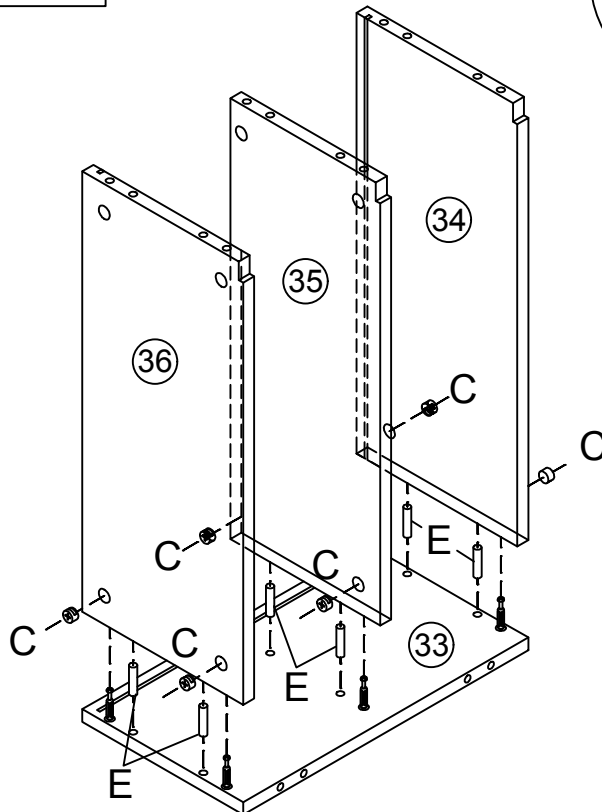

31

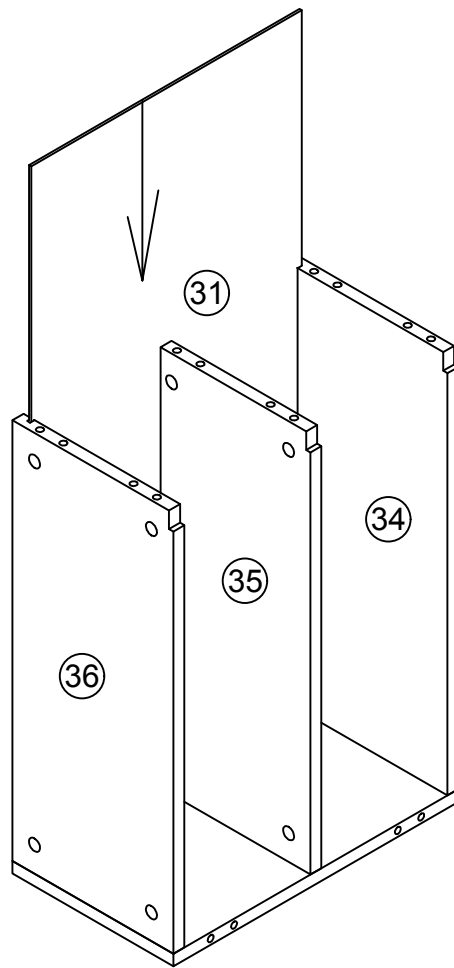

32



E x 6



C x 6

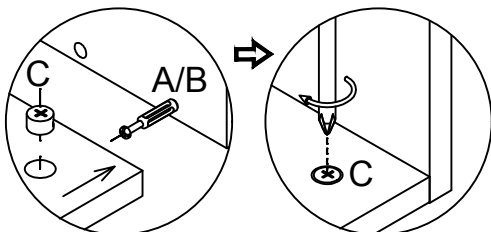
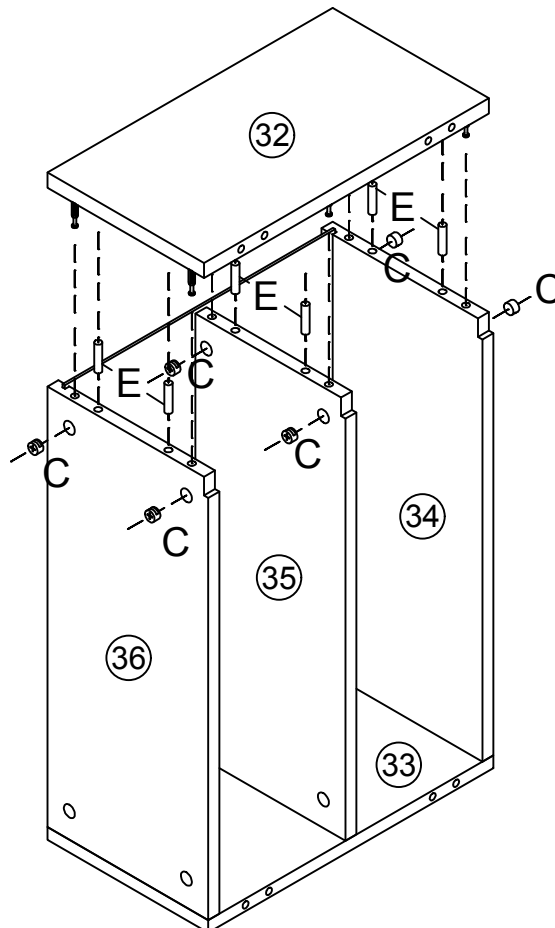

33



V x 4

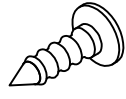

J x 4

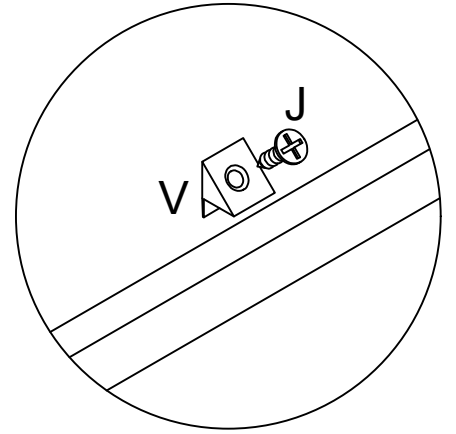
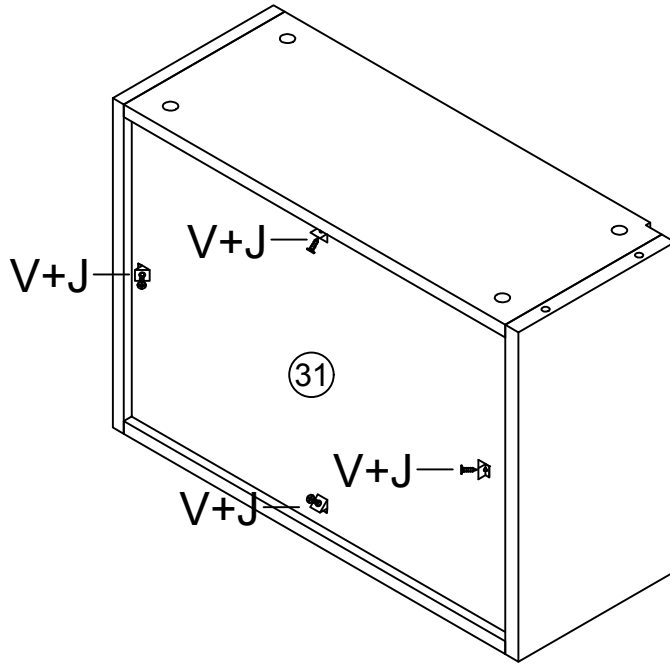

34



G x 4

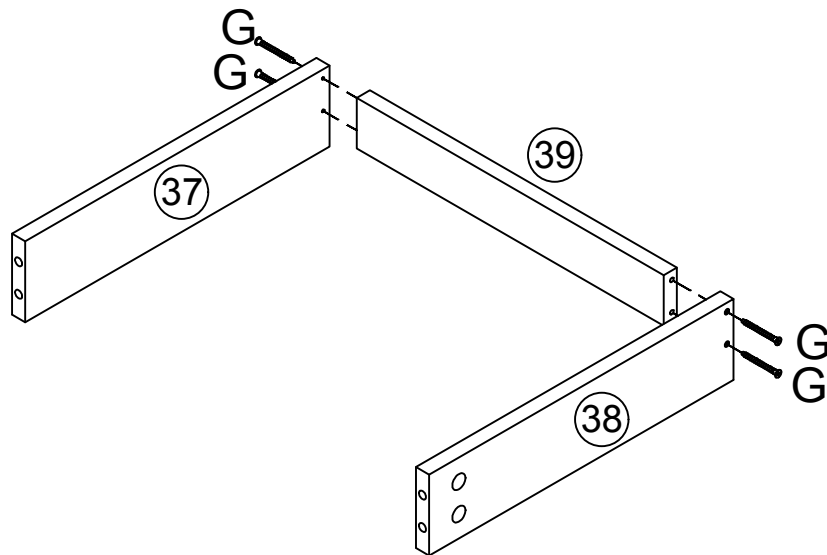

35

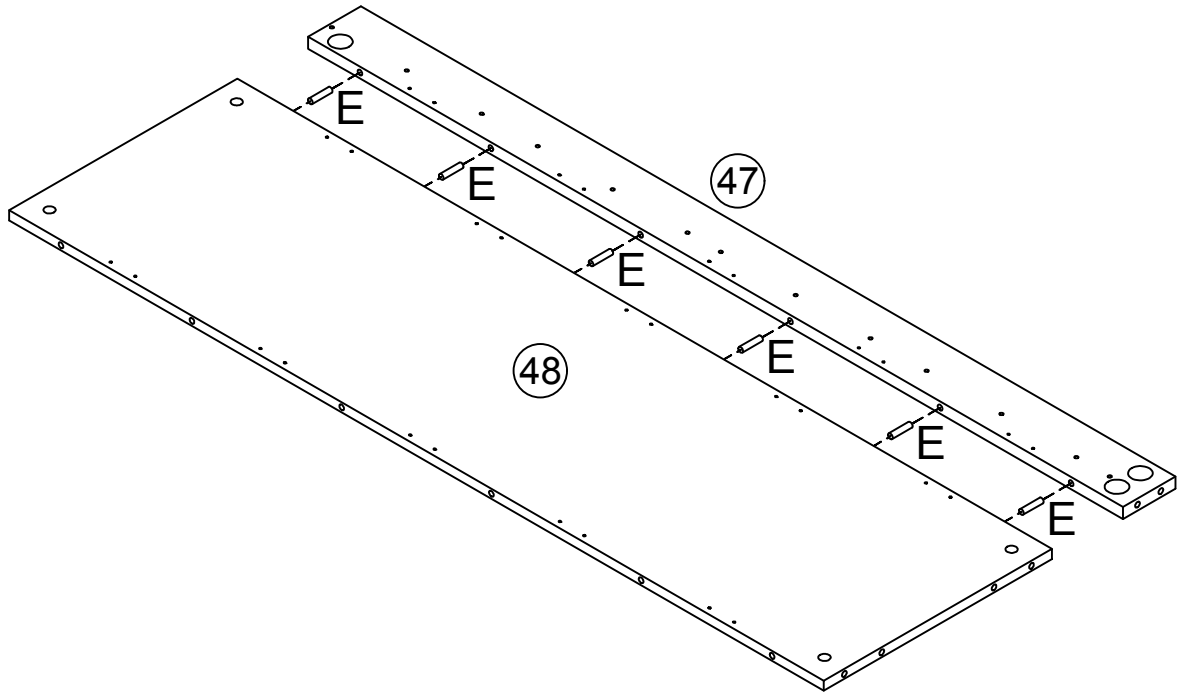
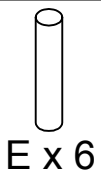

36

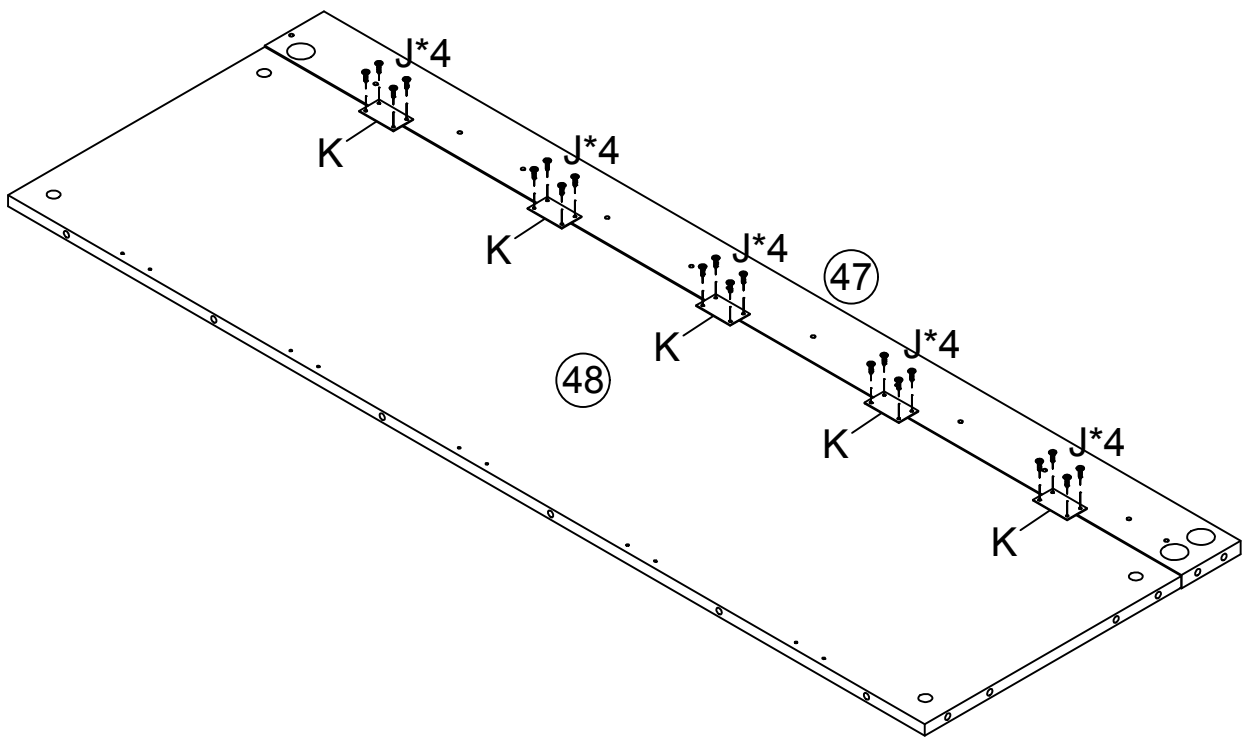
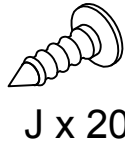
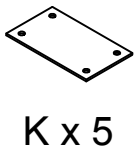

37



E x 4

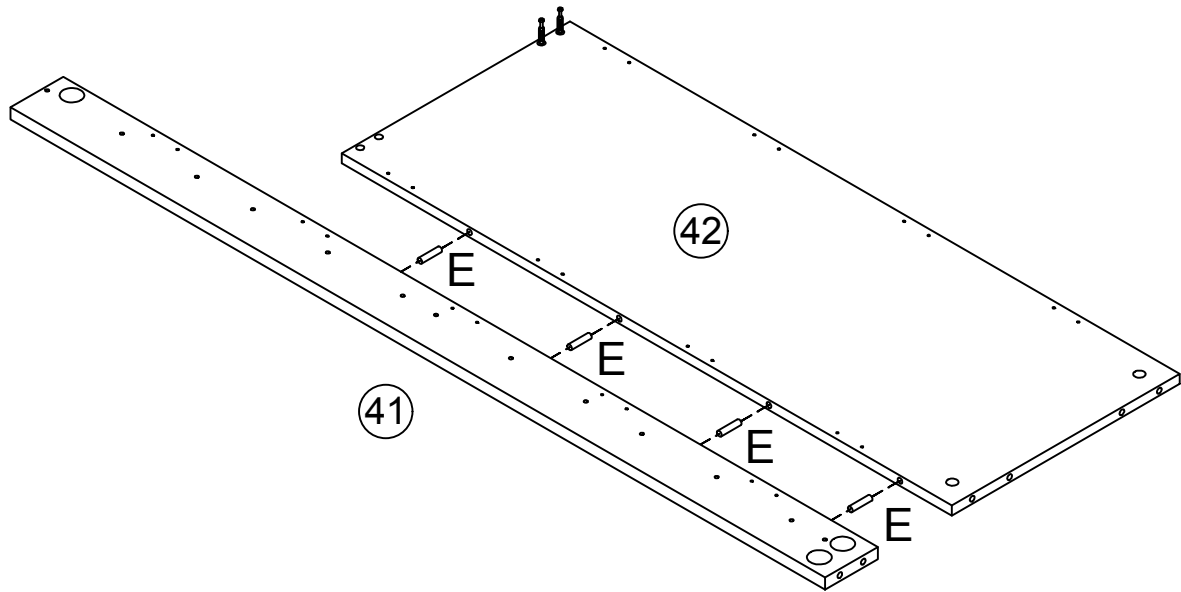

38

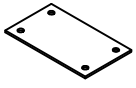

K x 4

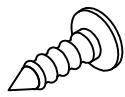

J x 16

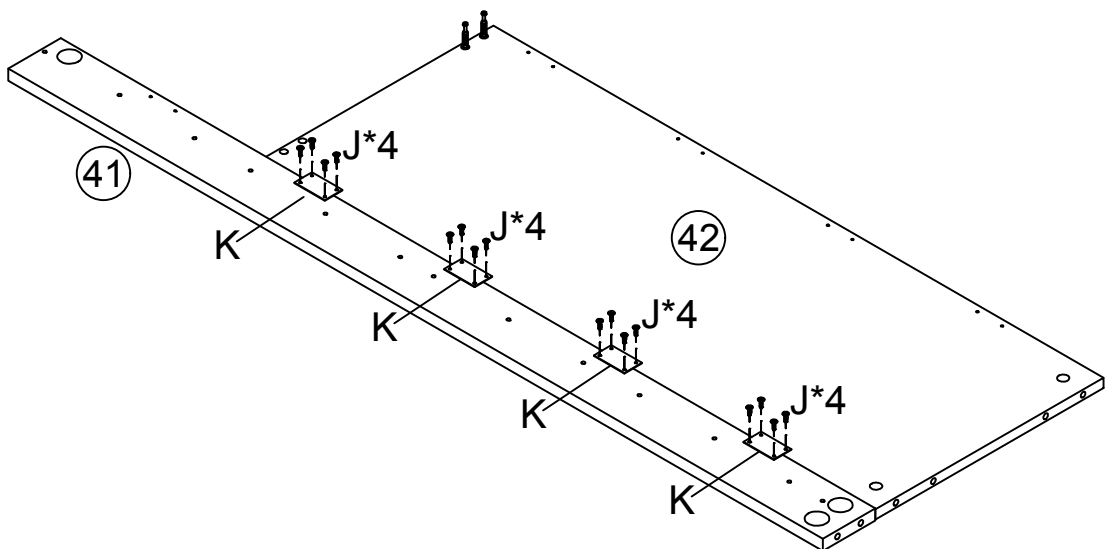

39



E x 1

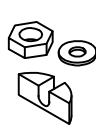

F x 2



T x 1

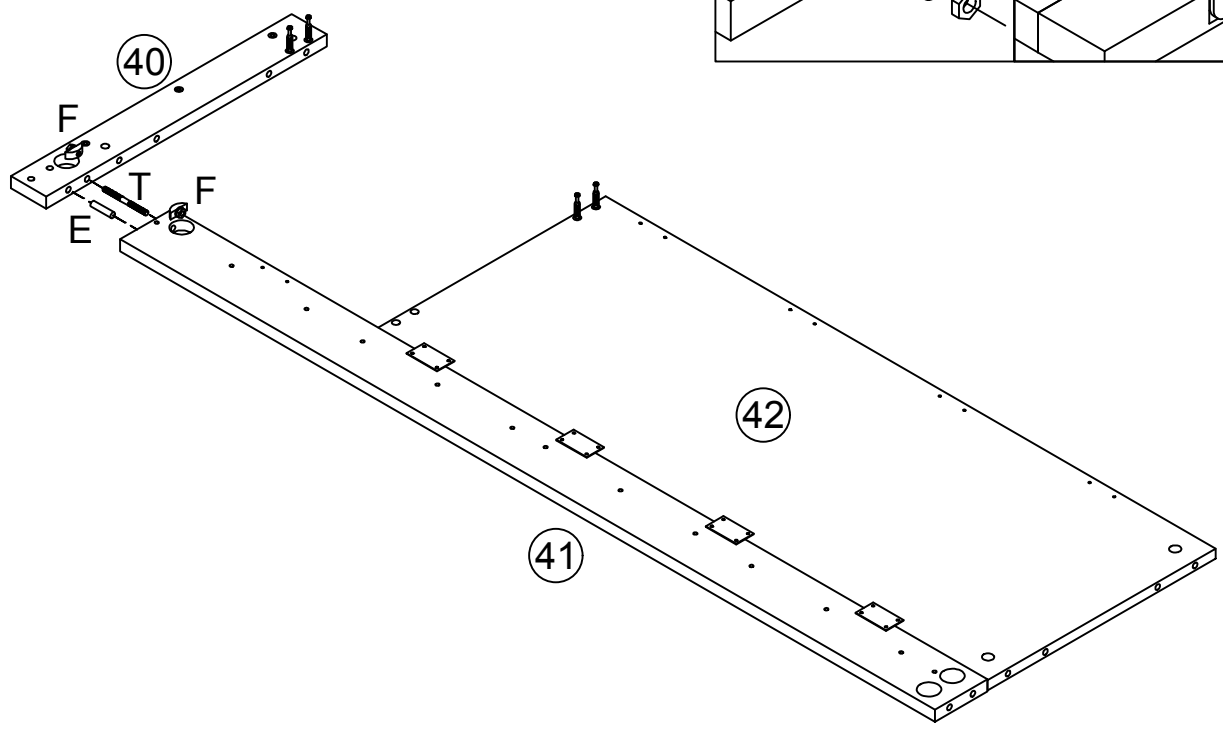
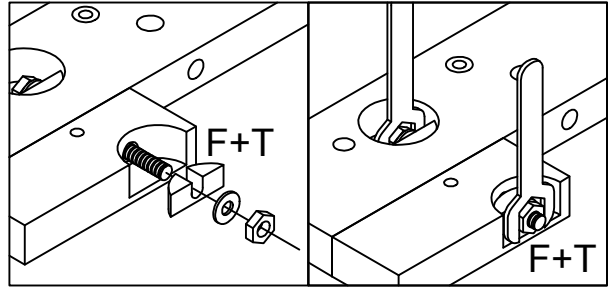

40



E x 2

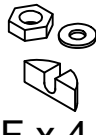

F x 4



S x 2

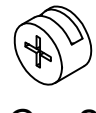

C x 2

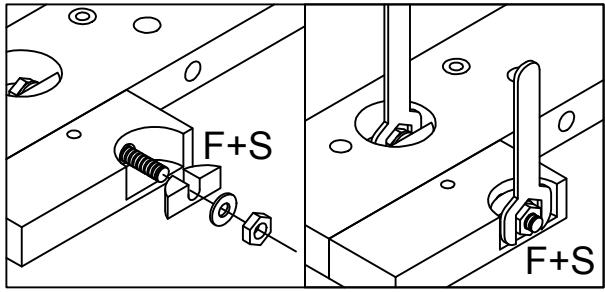
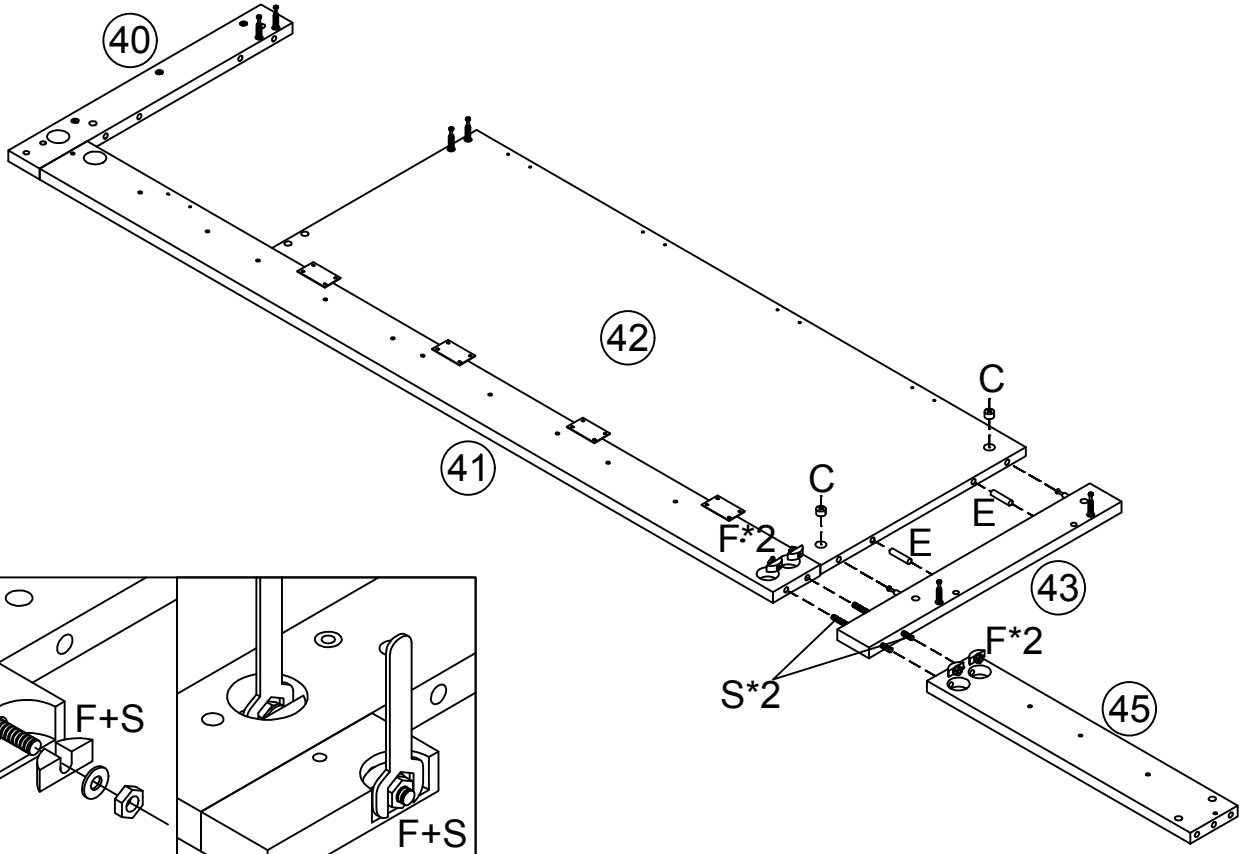

41



E x 1



H x 2



L x 2

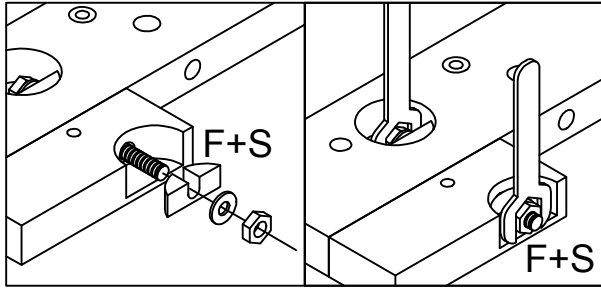
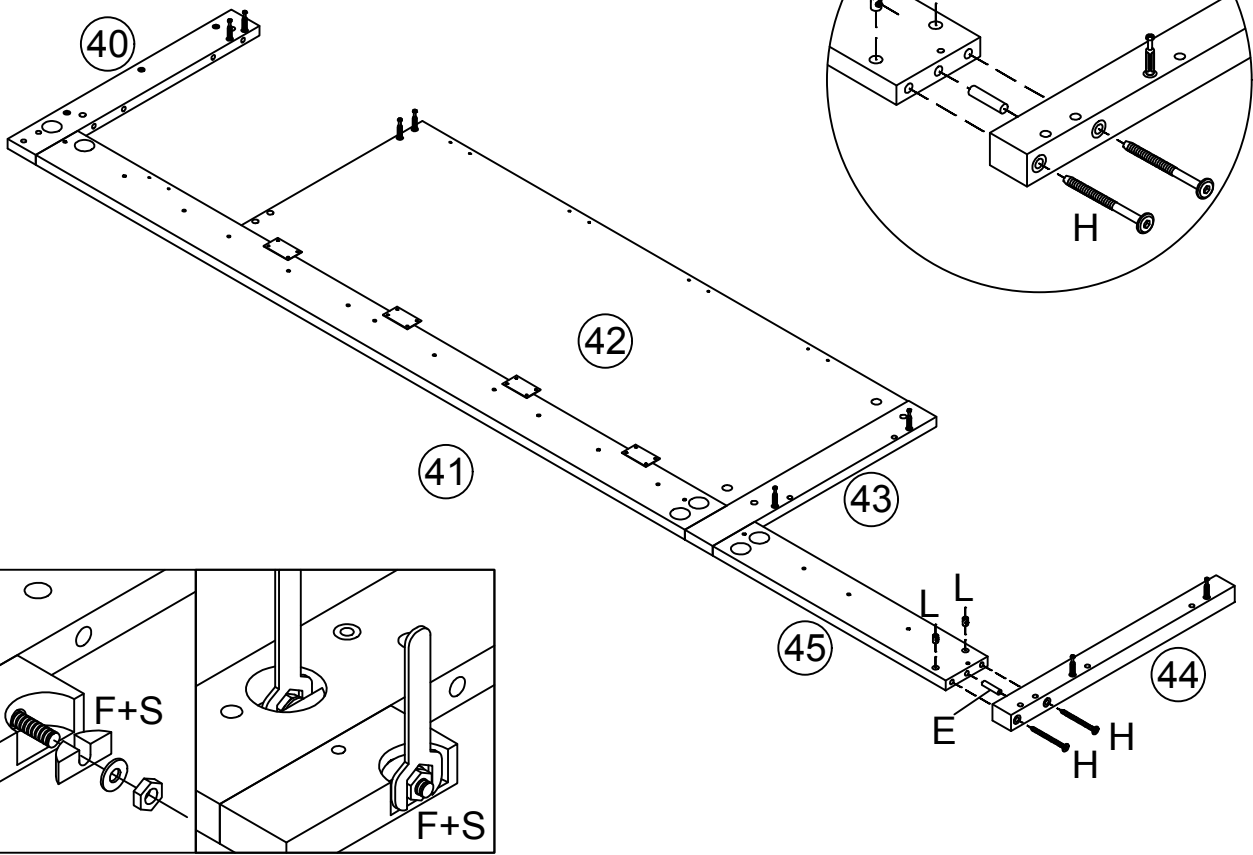

42



E x 3

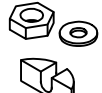

F x 2



T x 1



C x 2

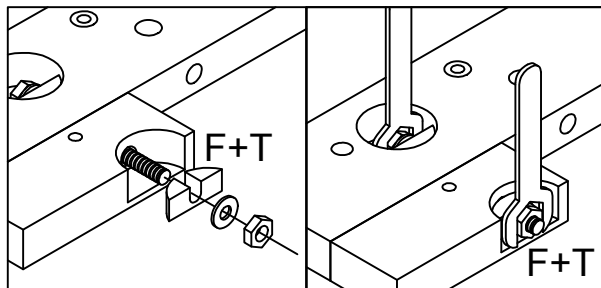
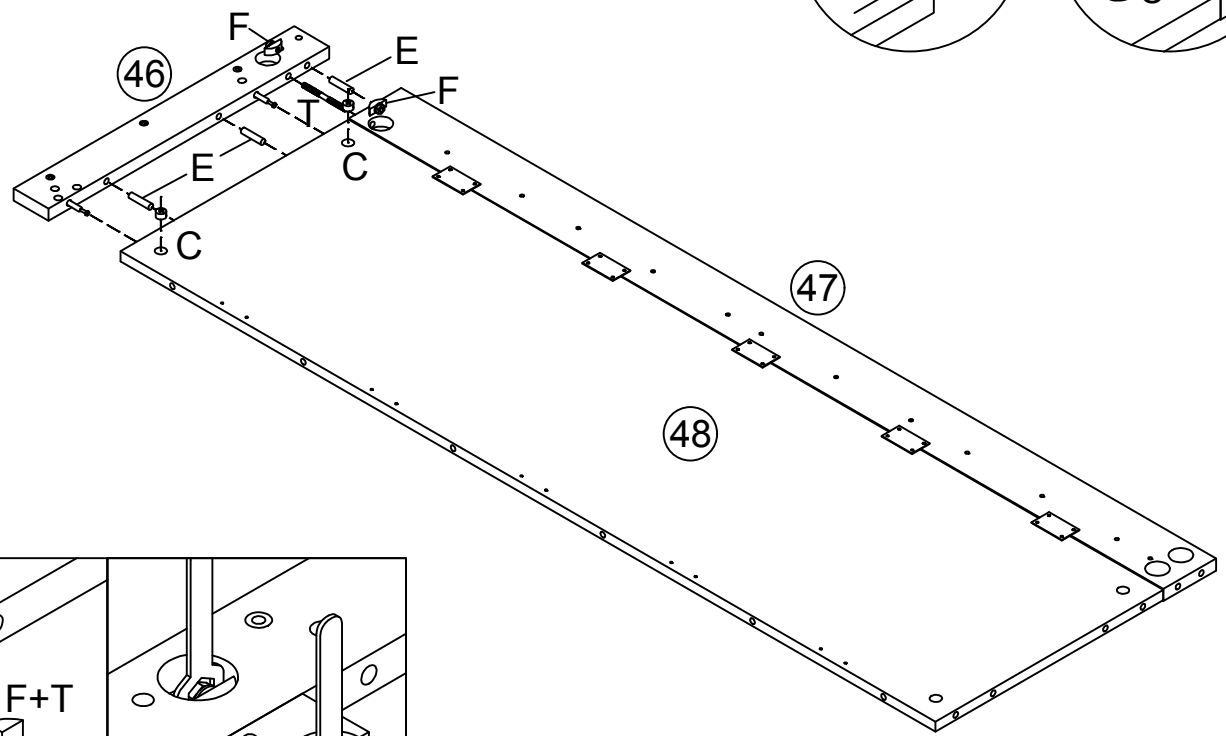

43



E x 2

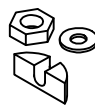

F x 4



S x 2



C x 2

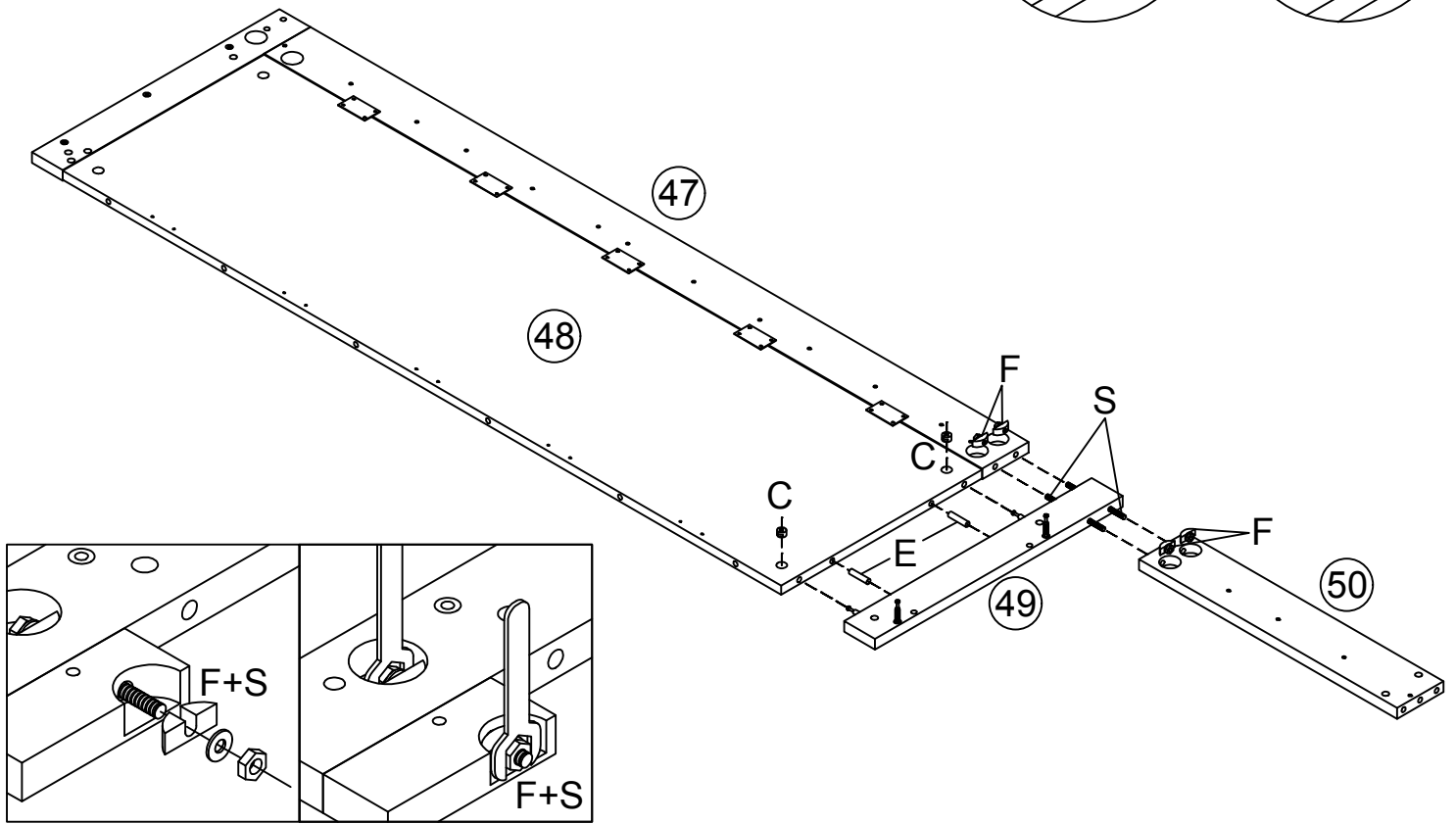
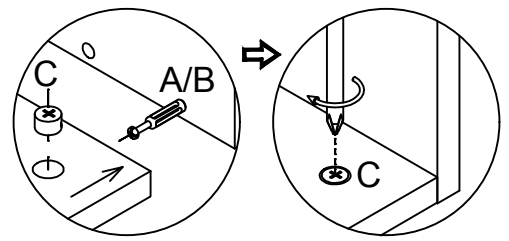

44



E x 1



H x 2



L x 2

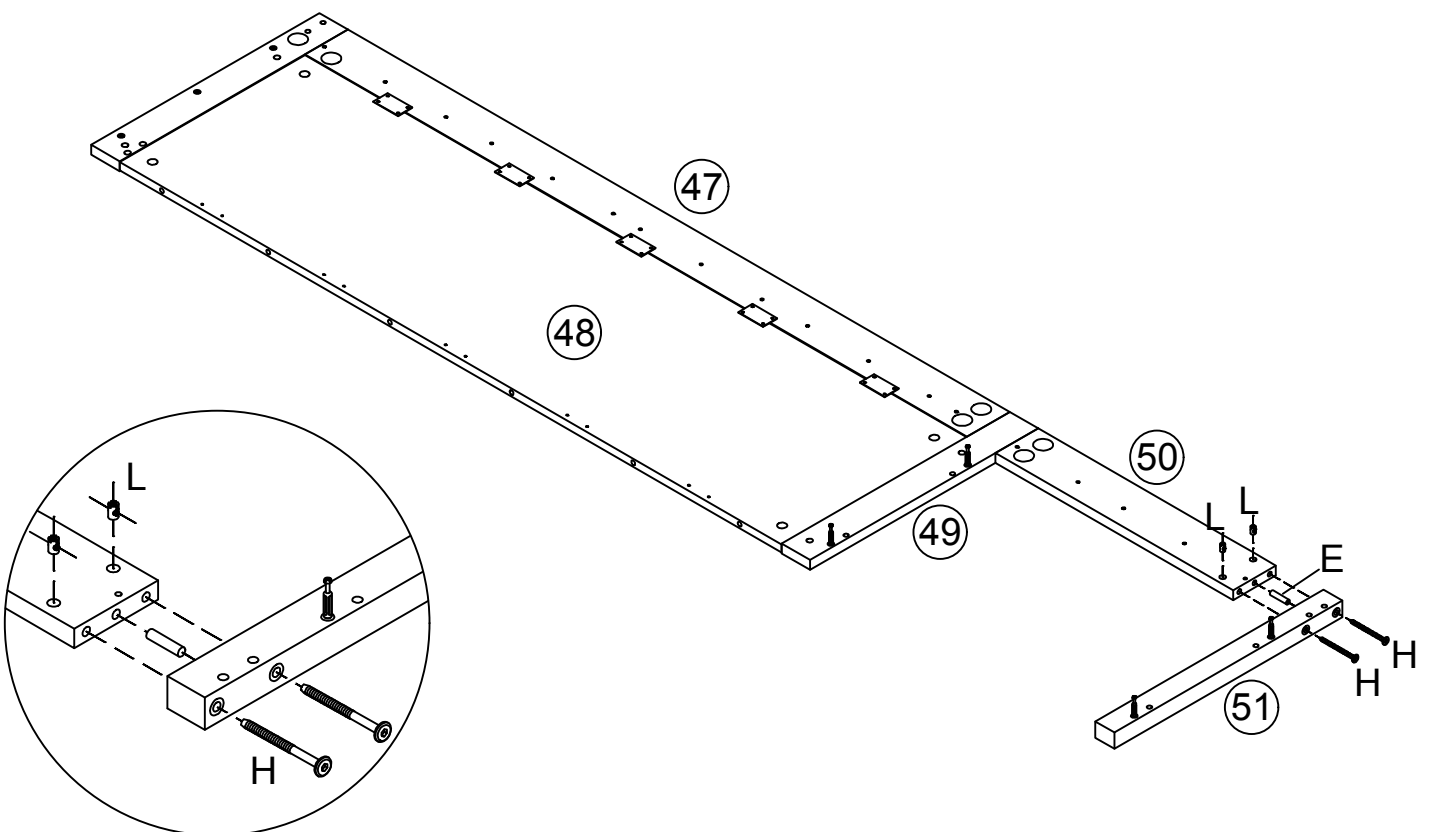

45

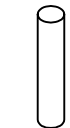

E x 4



C x 8

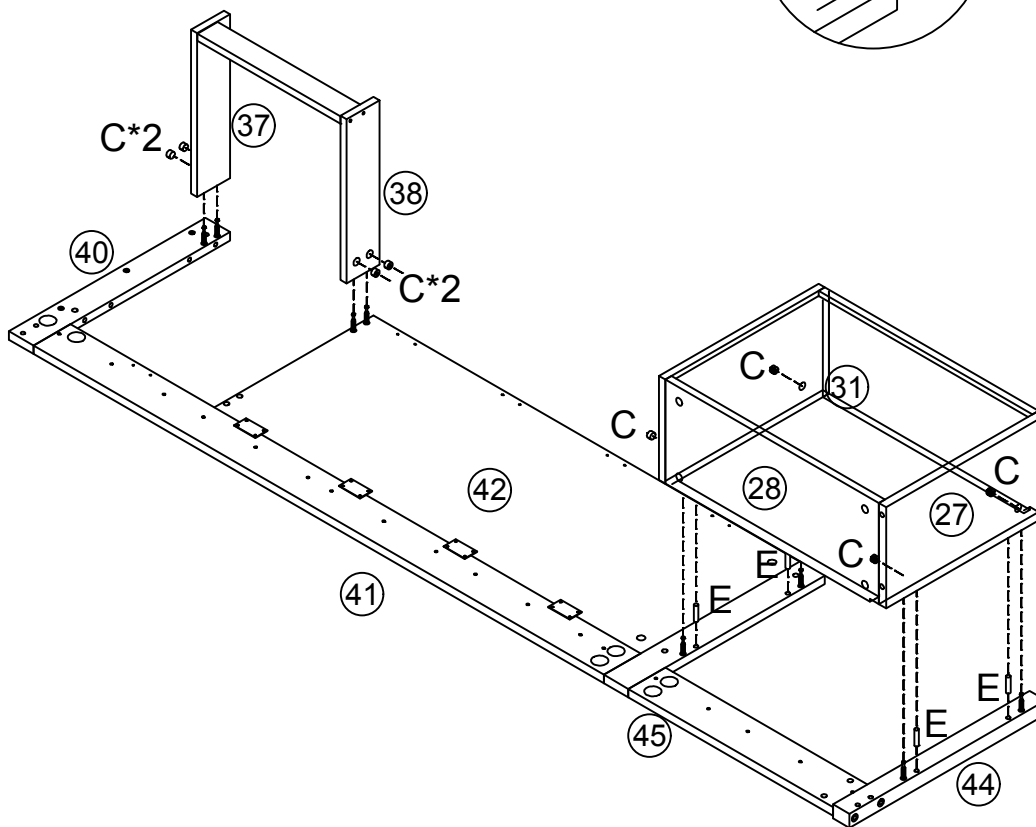
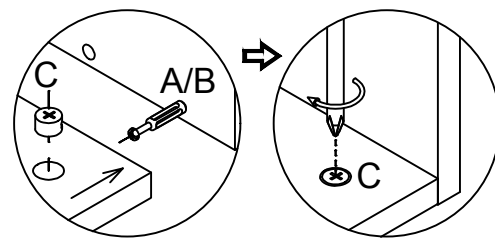

46

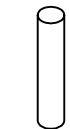

E x 4



C x 4

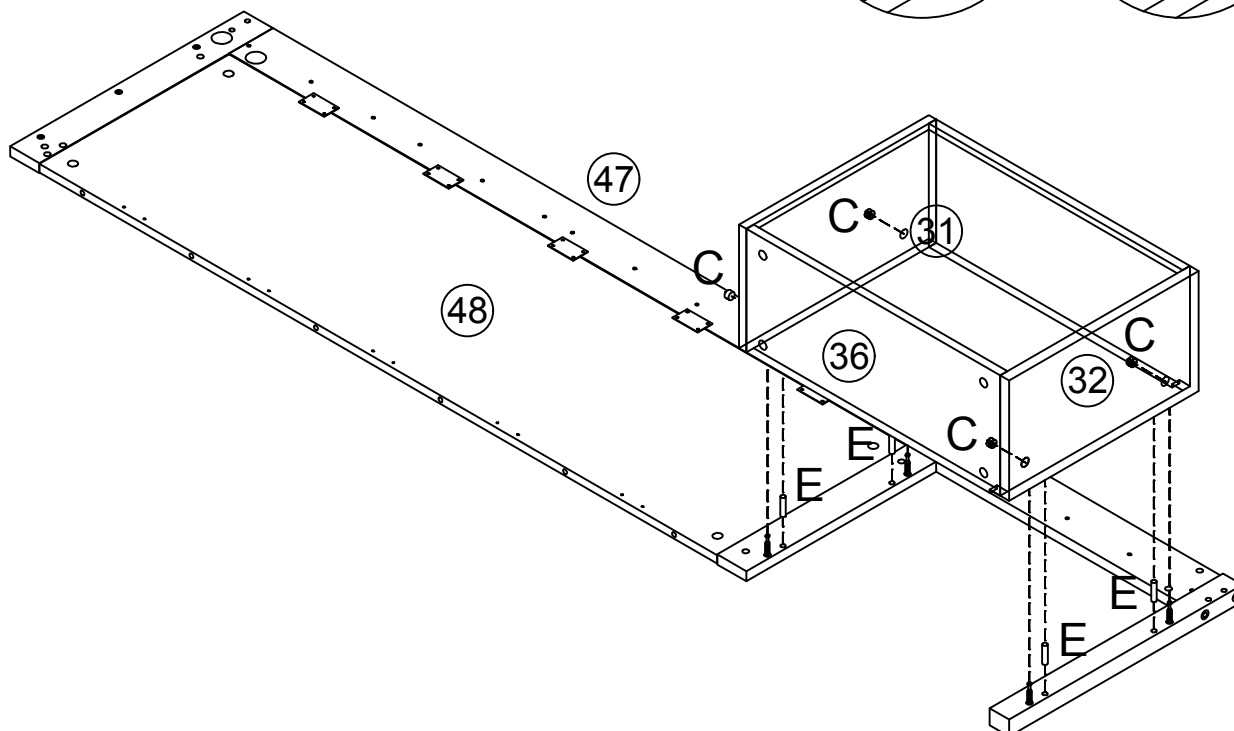
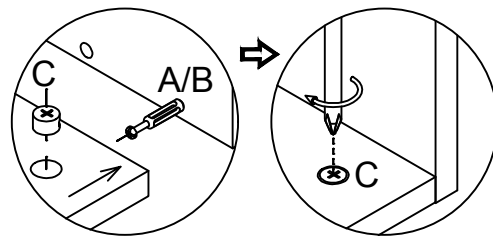

47



X x 12

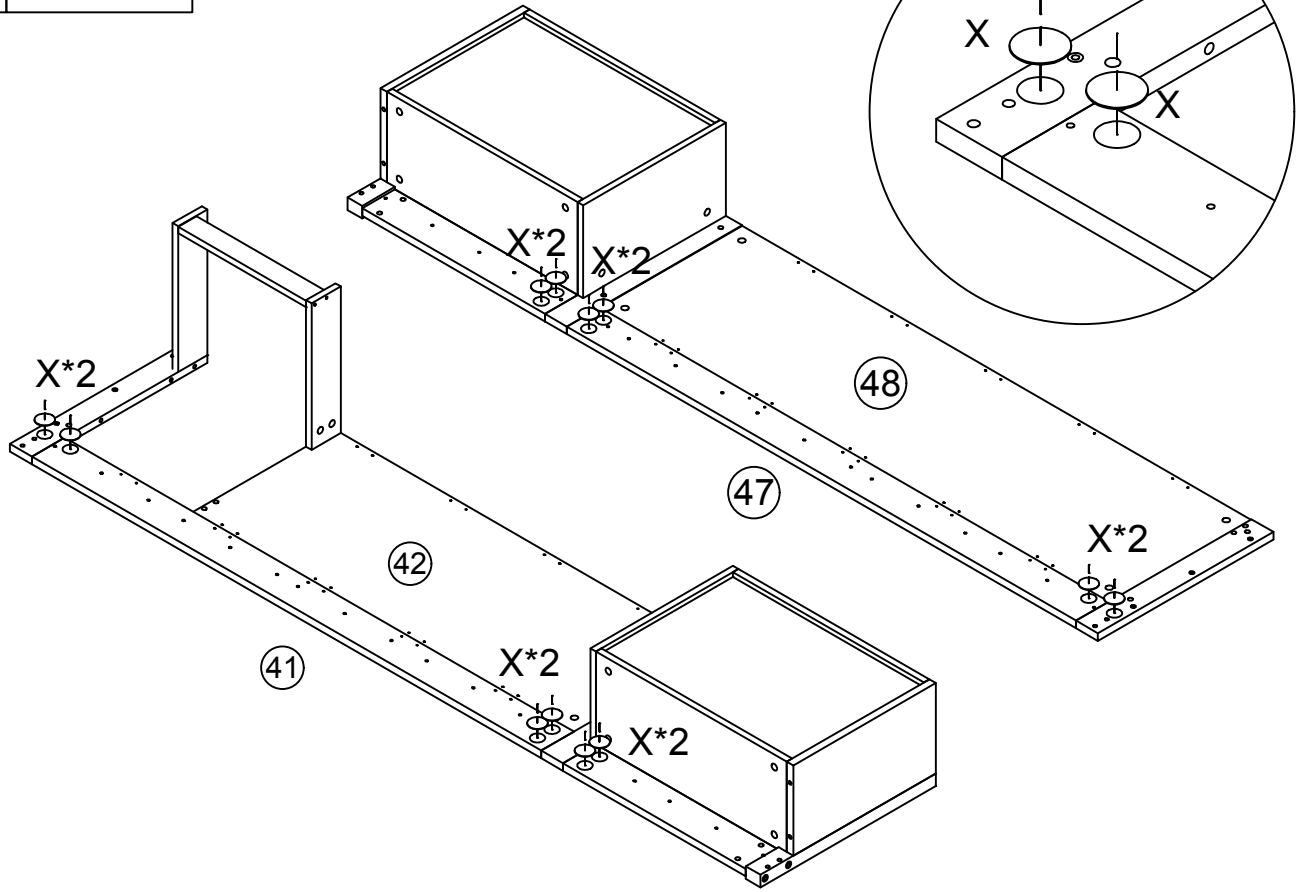

48



W x 36

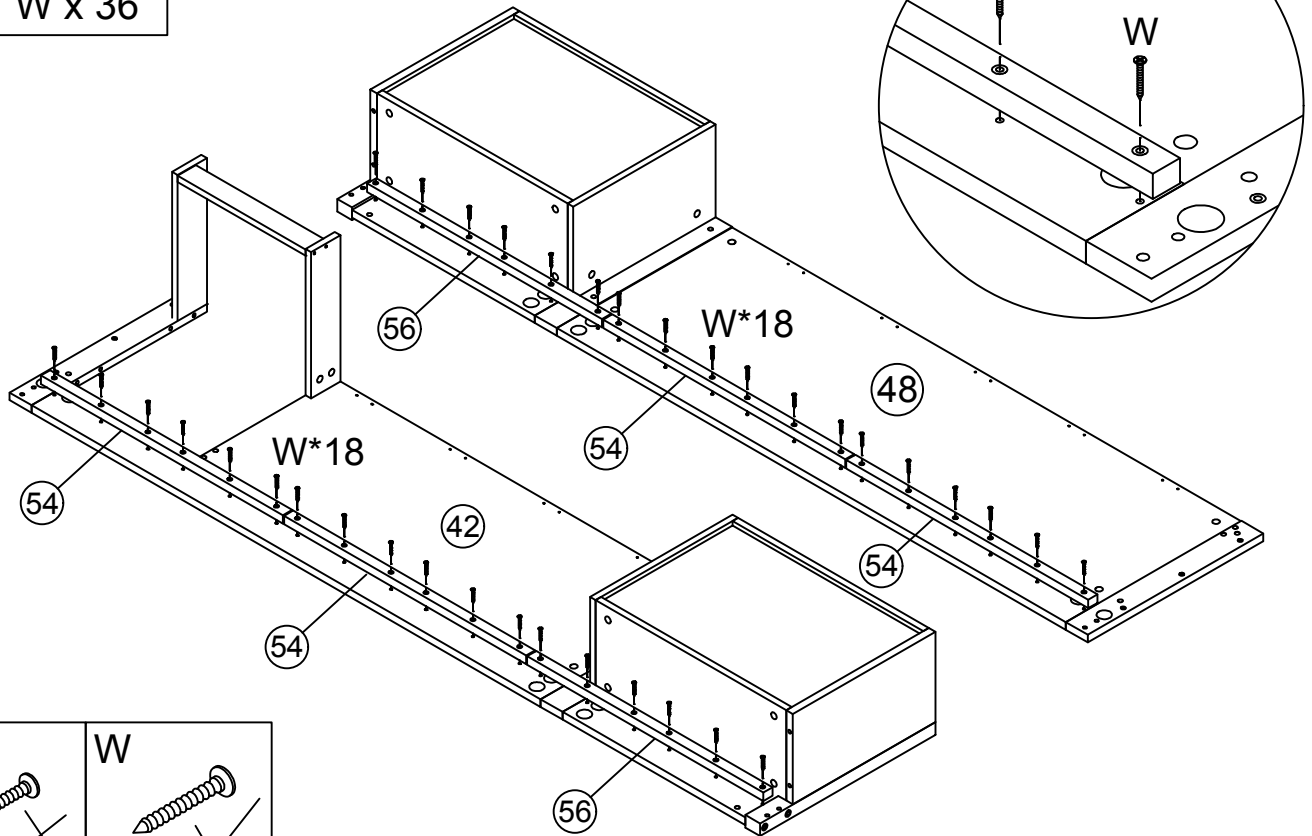

BB



Ø3*30

W



Ø4*30

49



H x 4



L x 4

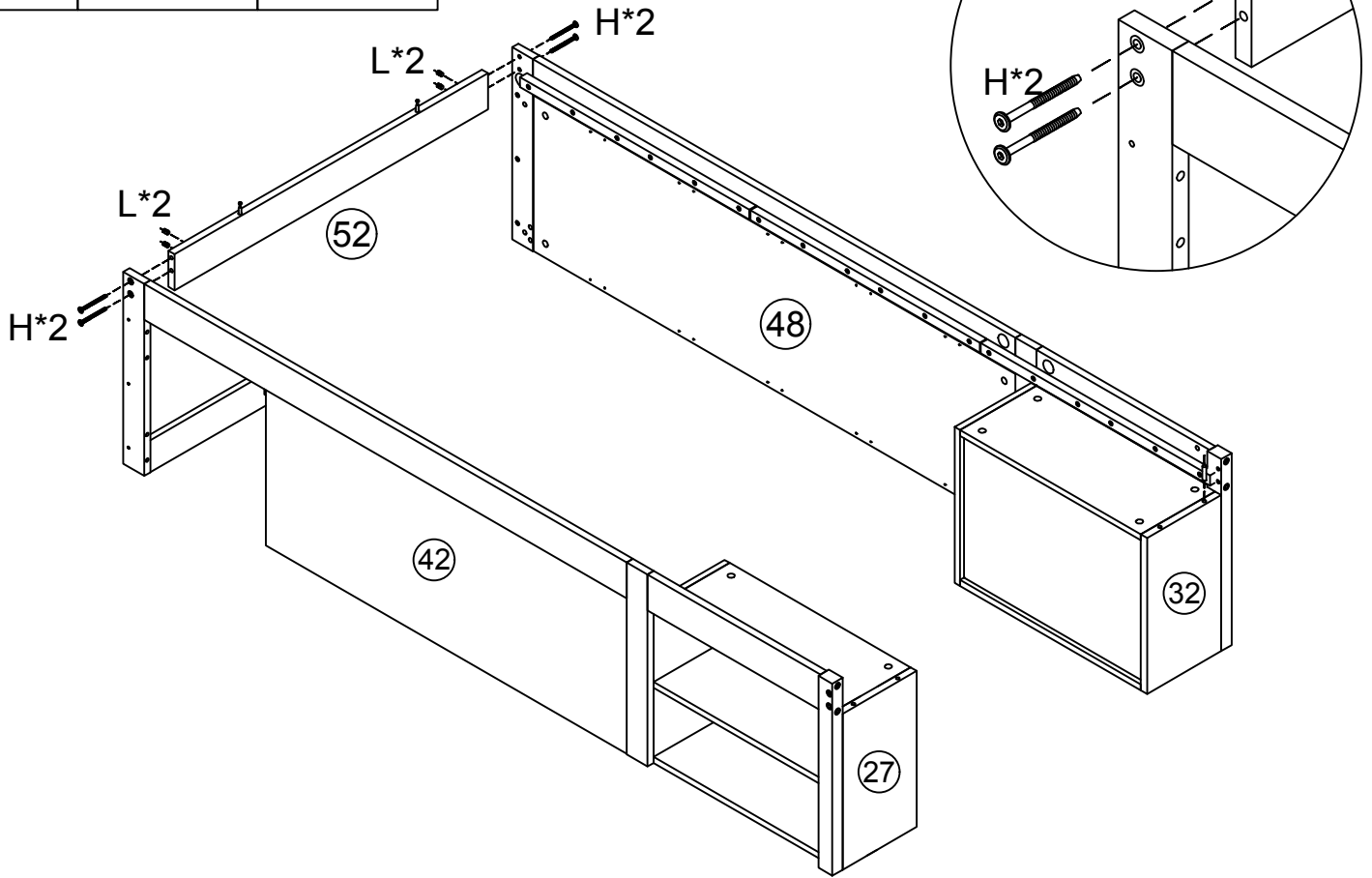

50



E x 4

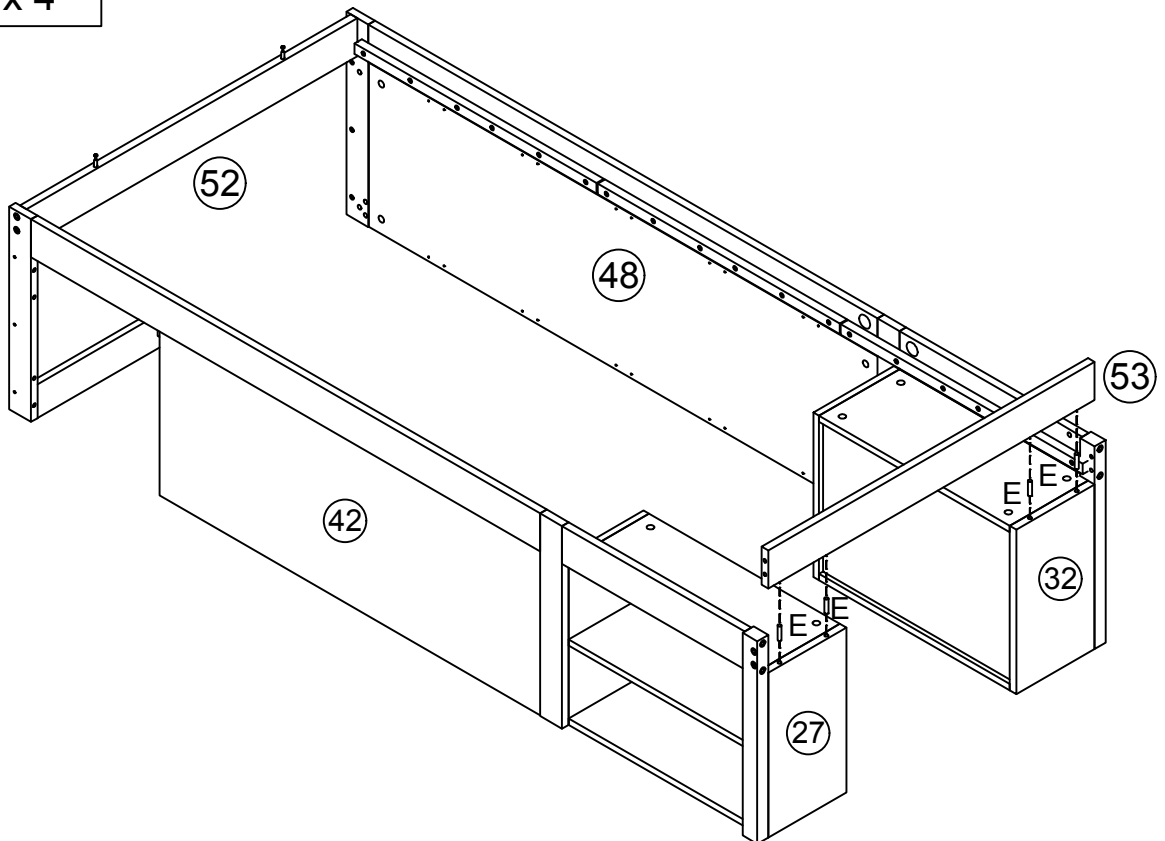

51



H x 4



L x 4

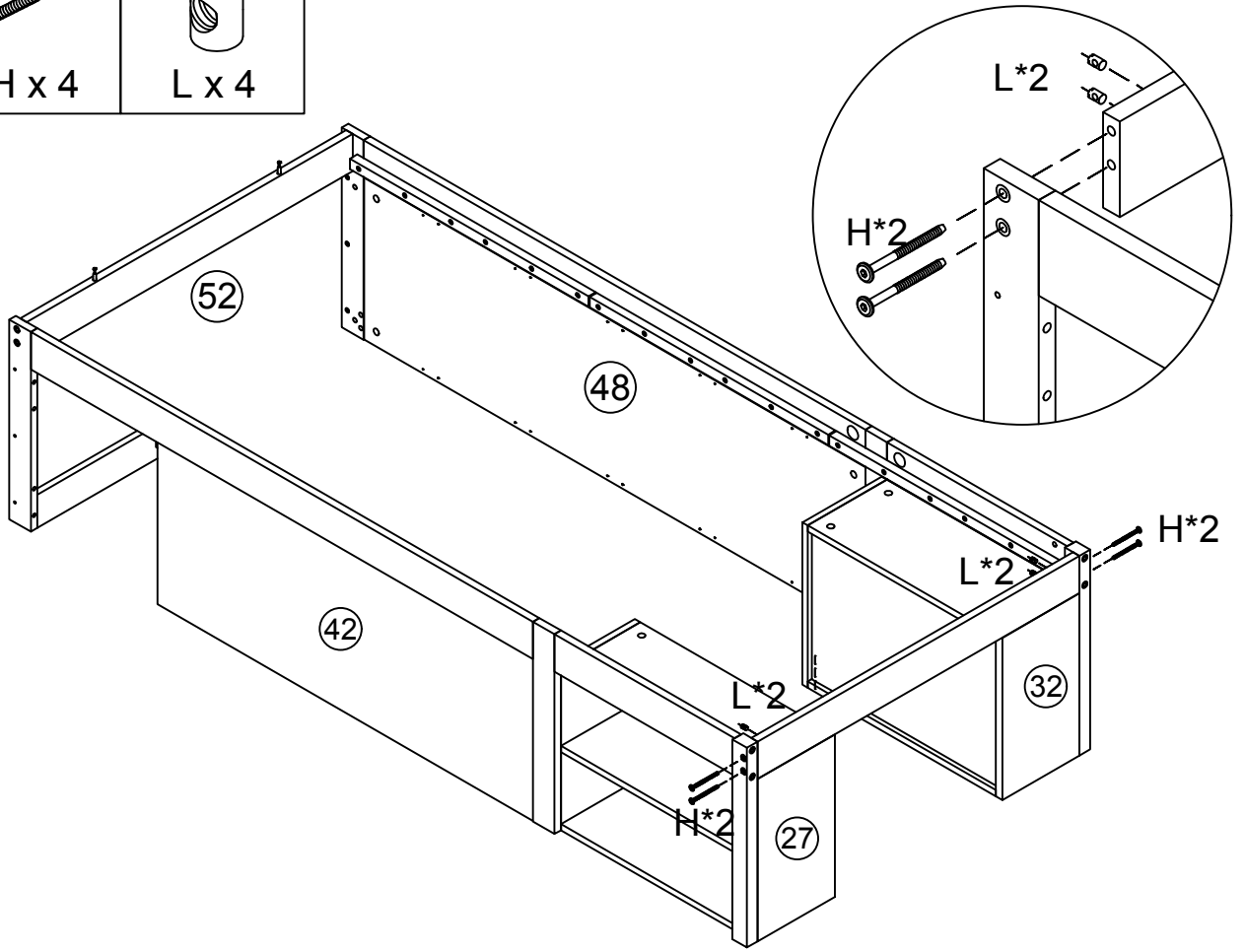

52



C x 2

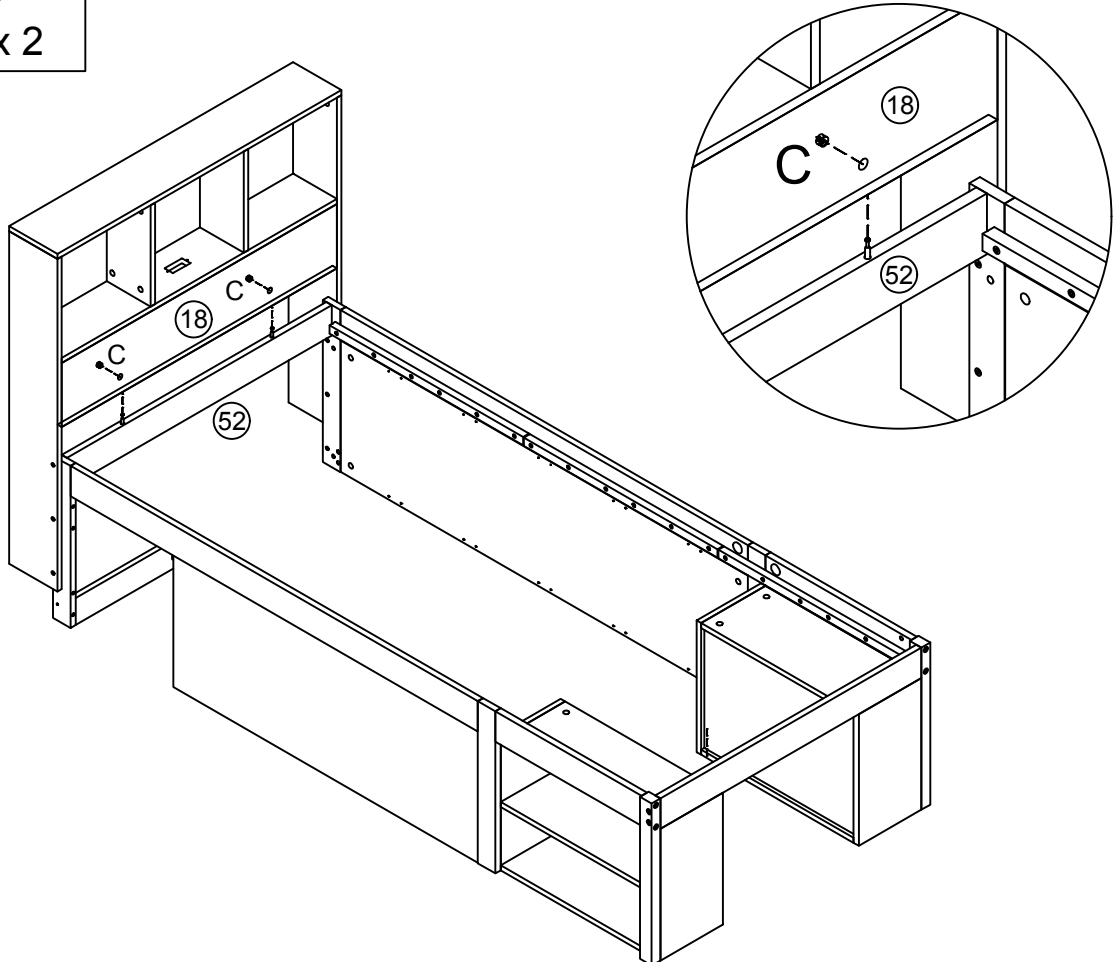

53

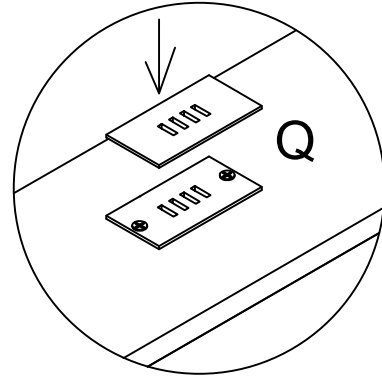
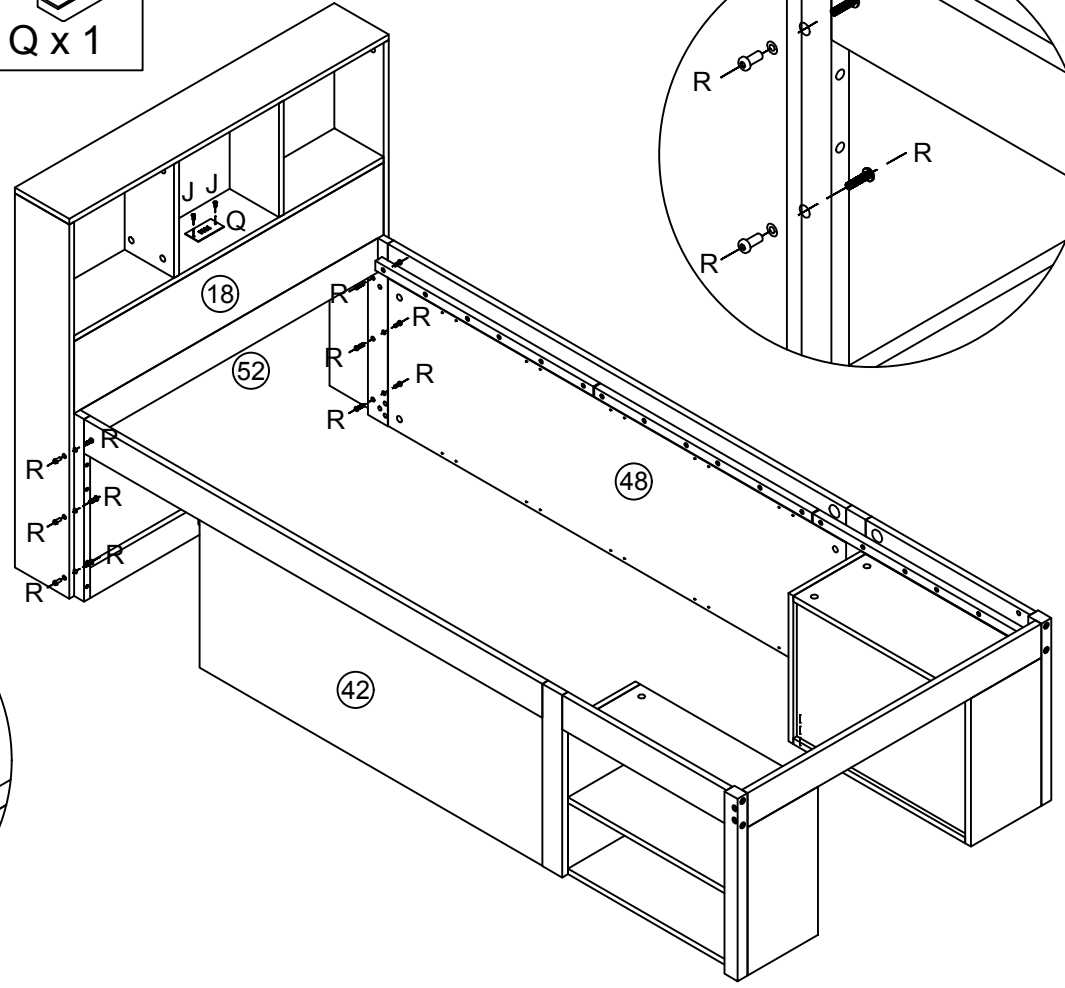
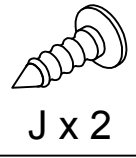
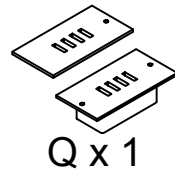

54

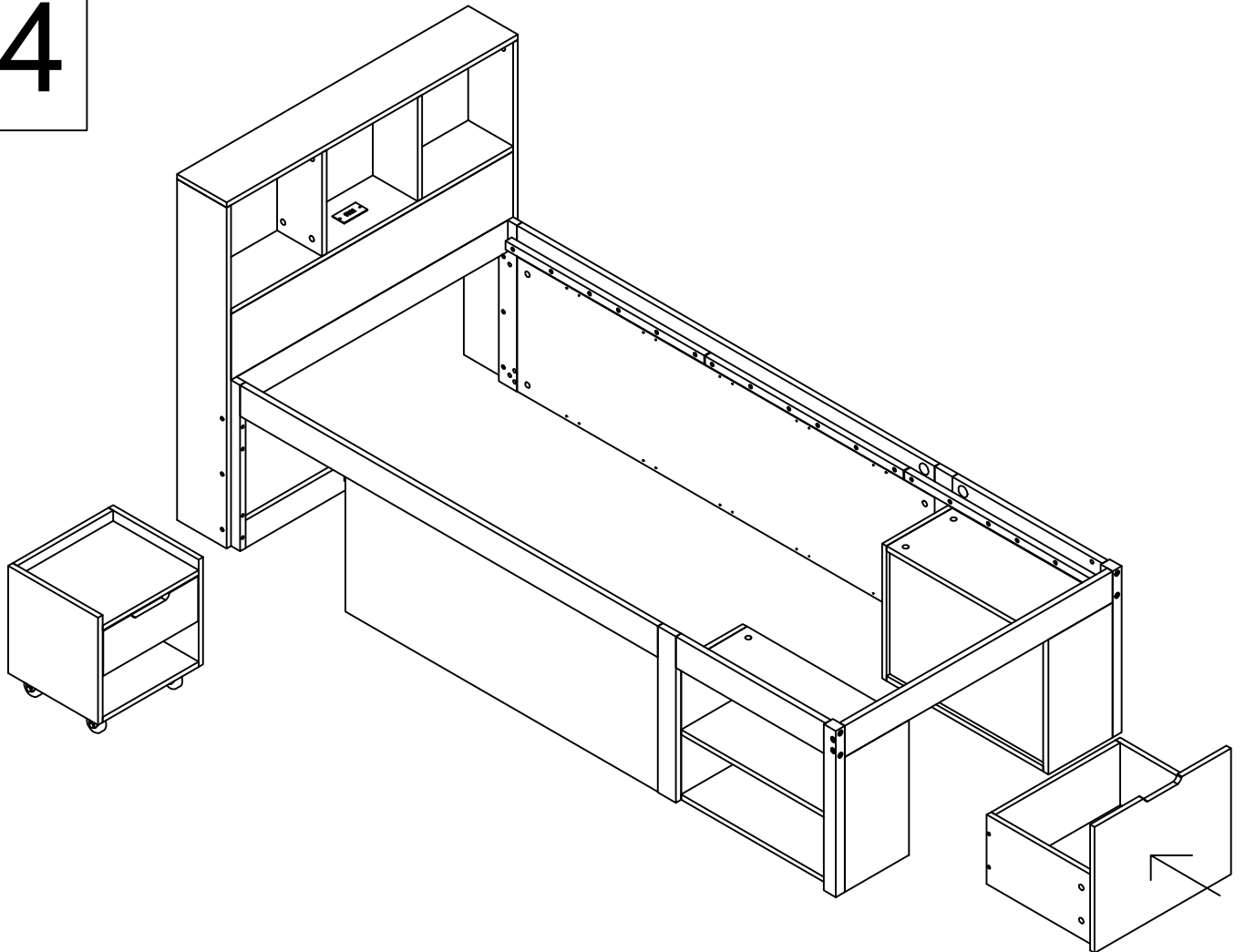

55

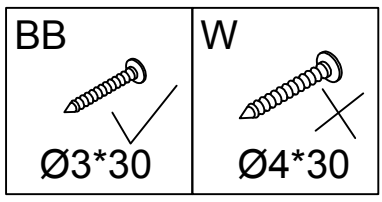
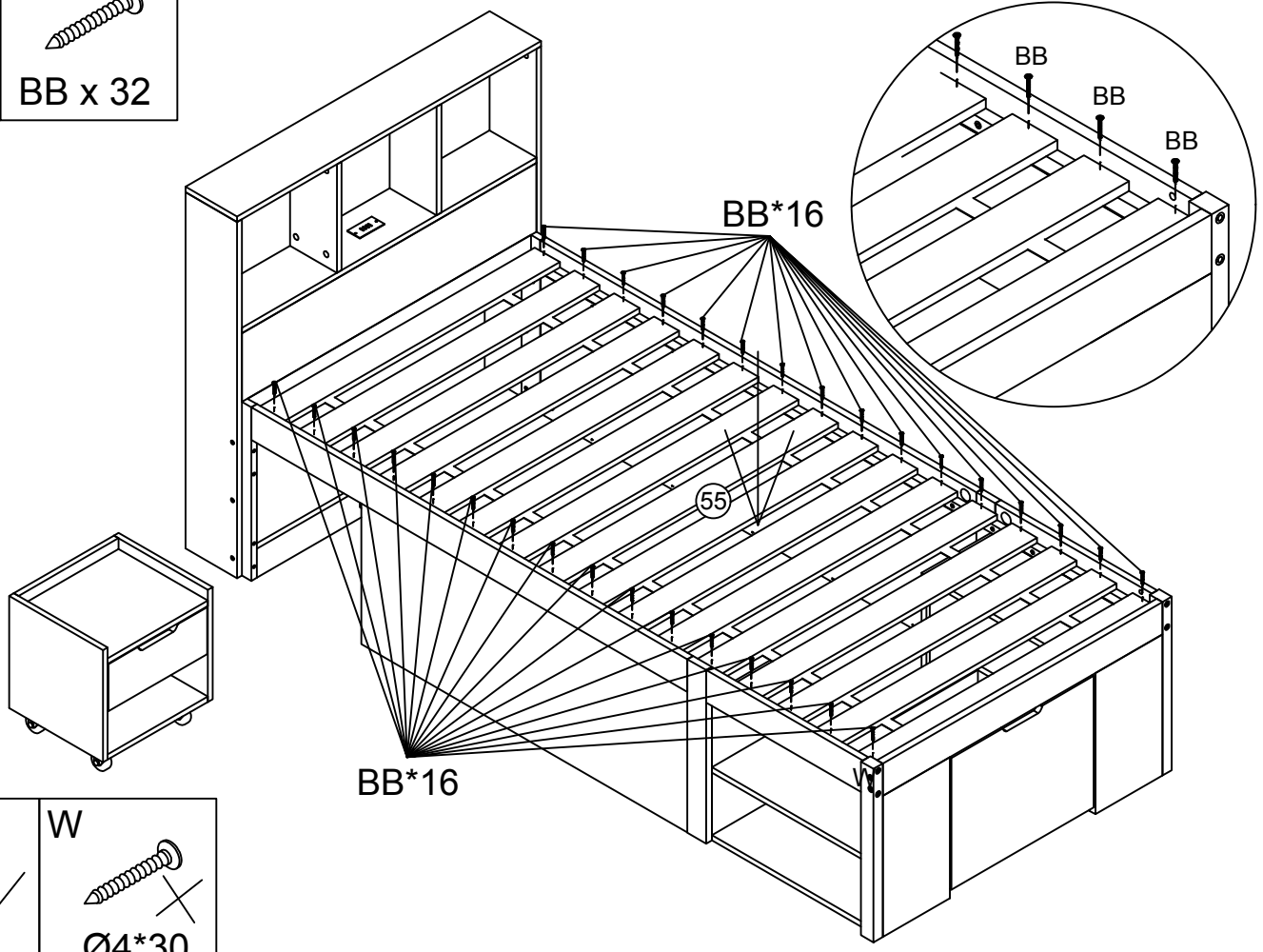

56

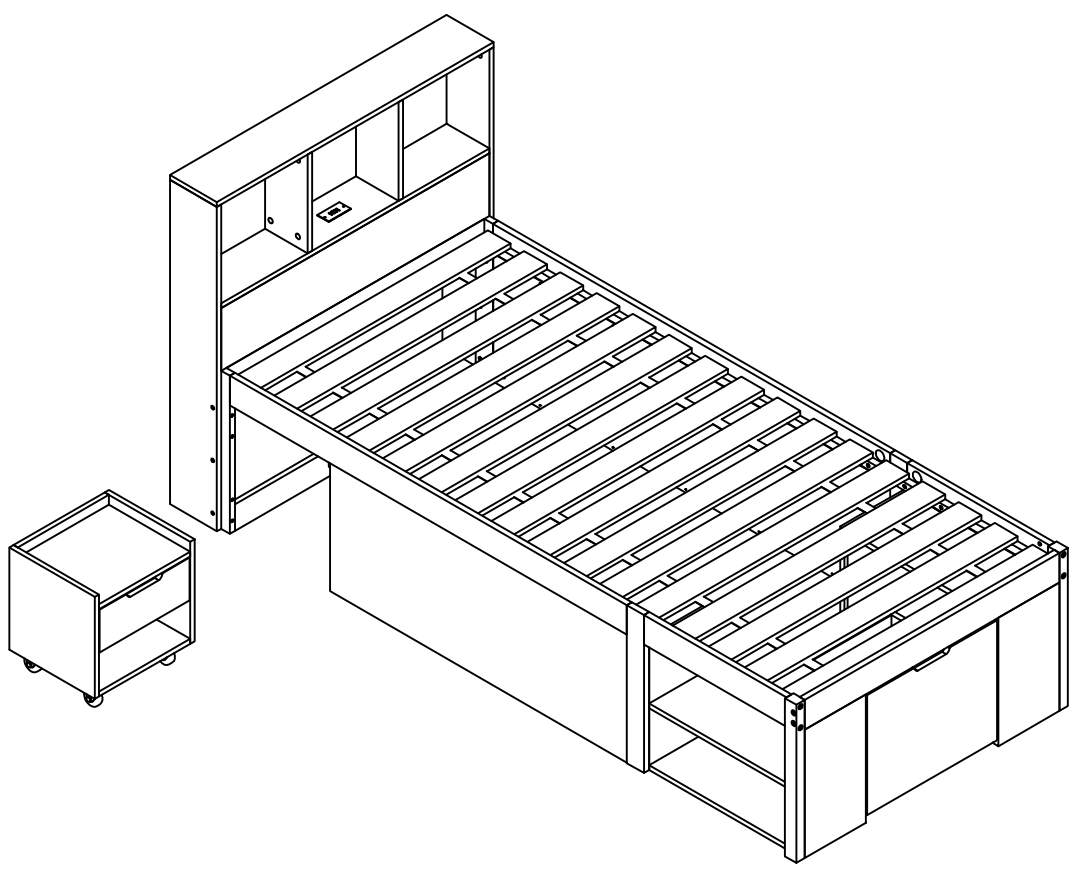

57



Y x 102

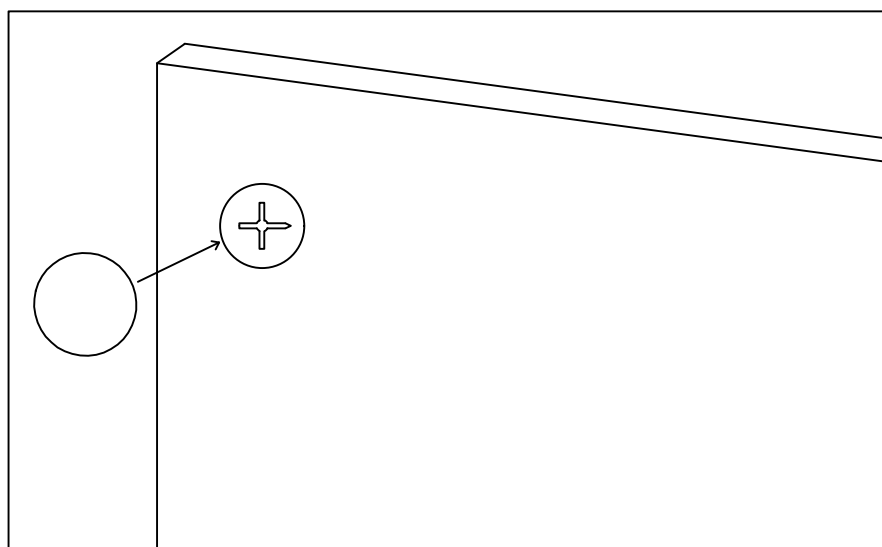

UK: After installing the product, stick the number Y on the perforated position

FR: Une fois le produit installé, collez le numéro Y à l'endroit où il y a des trous

DE: Nach der Installation des Produkts kleben Sie die Nummer Y auf die perforierte Position

IT: Dopo l'installazione del prodotto, fissare il numero Y sulla posizione perforata

ES: Después de instalar el producto, pegue el número Y en la posición perforada

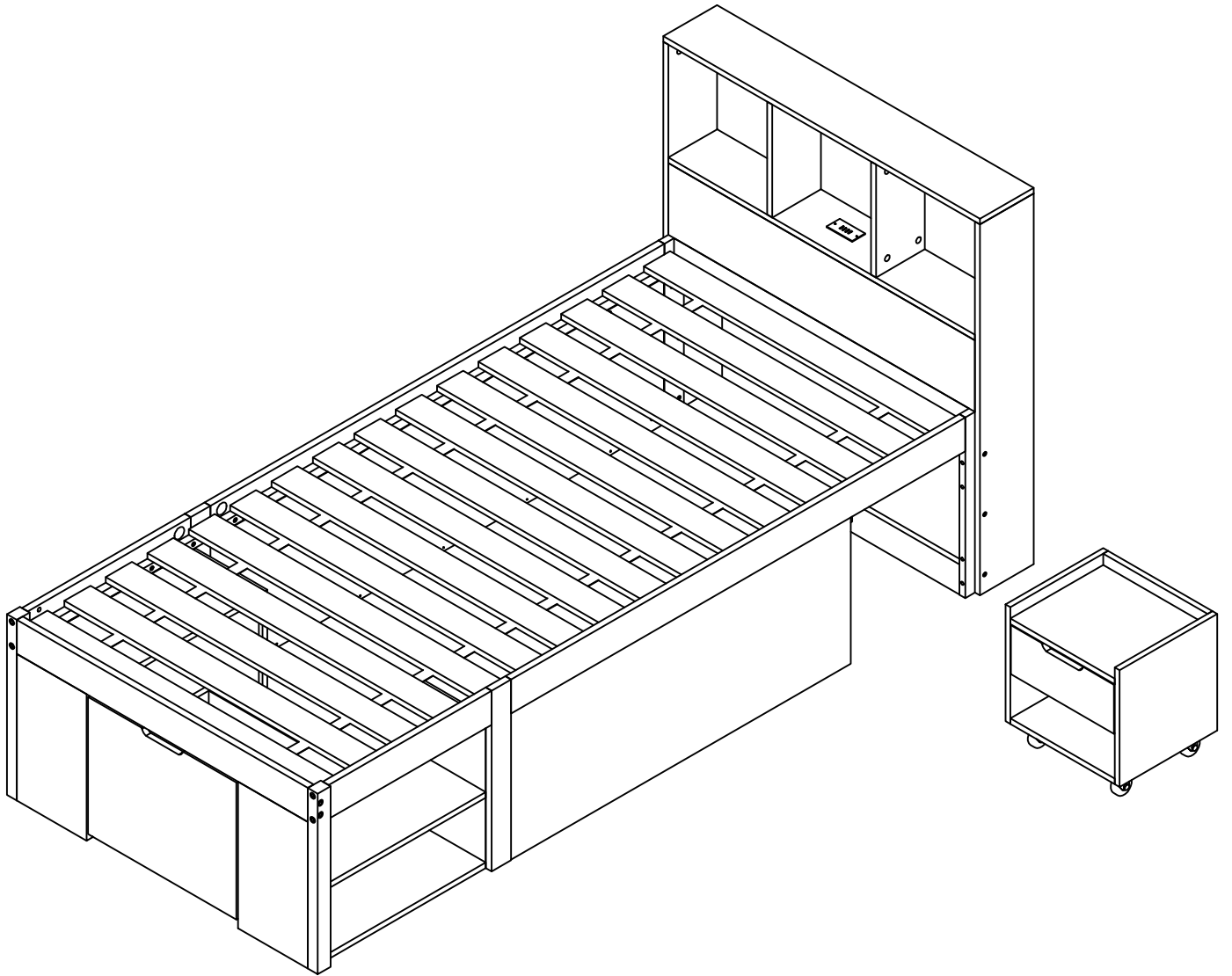

R : 44-73 PAGES

1



A x 14

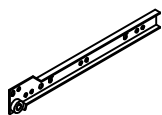

CL x 1

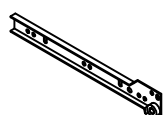

CR x 1

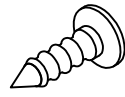

J x 4

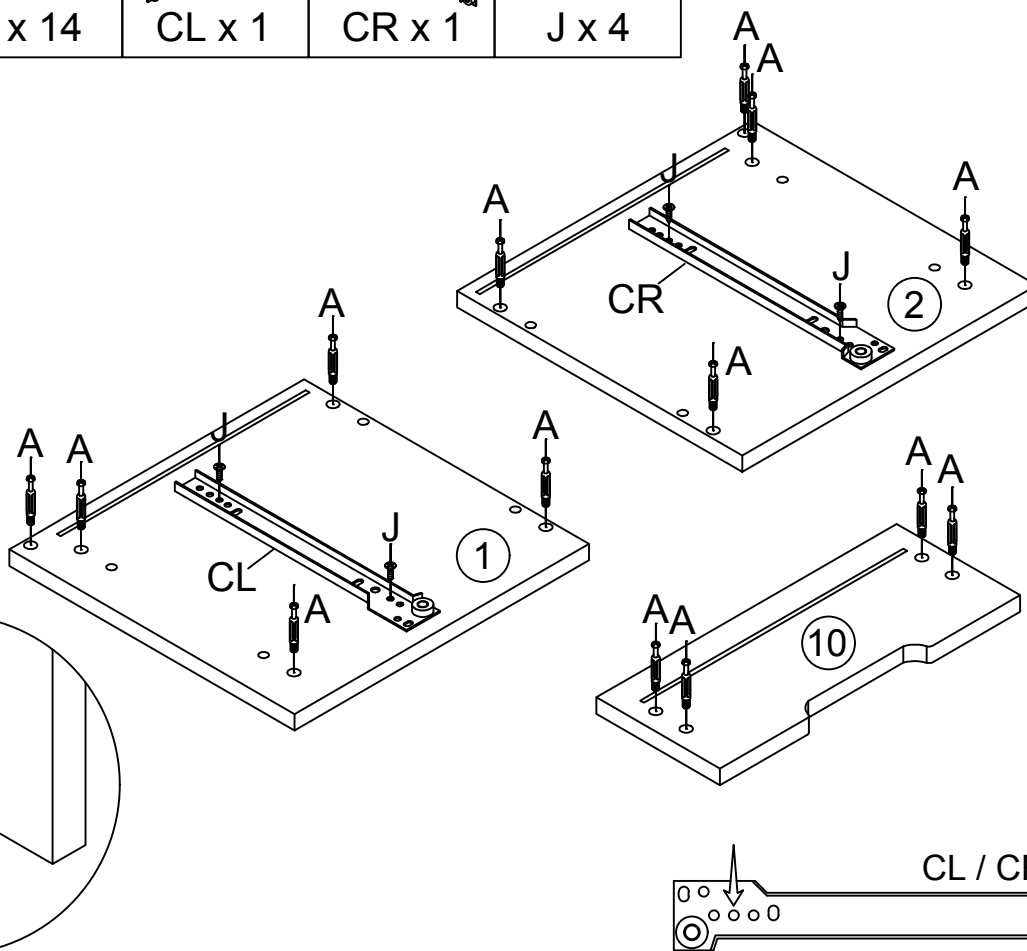

2

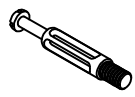

A x 16

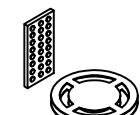

U x 1

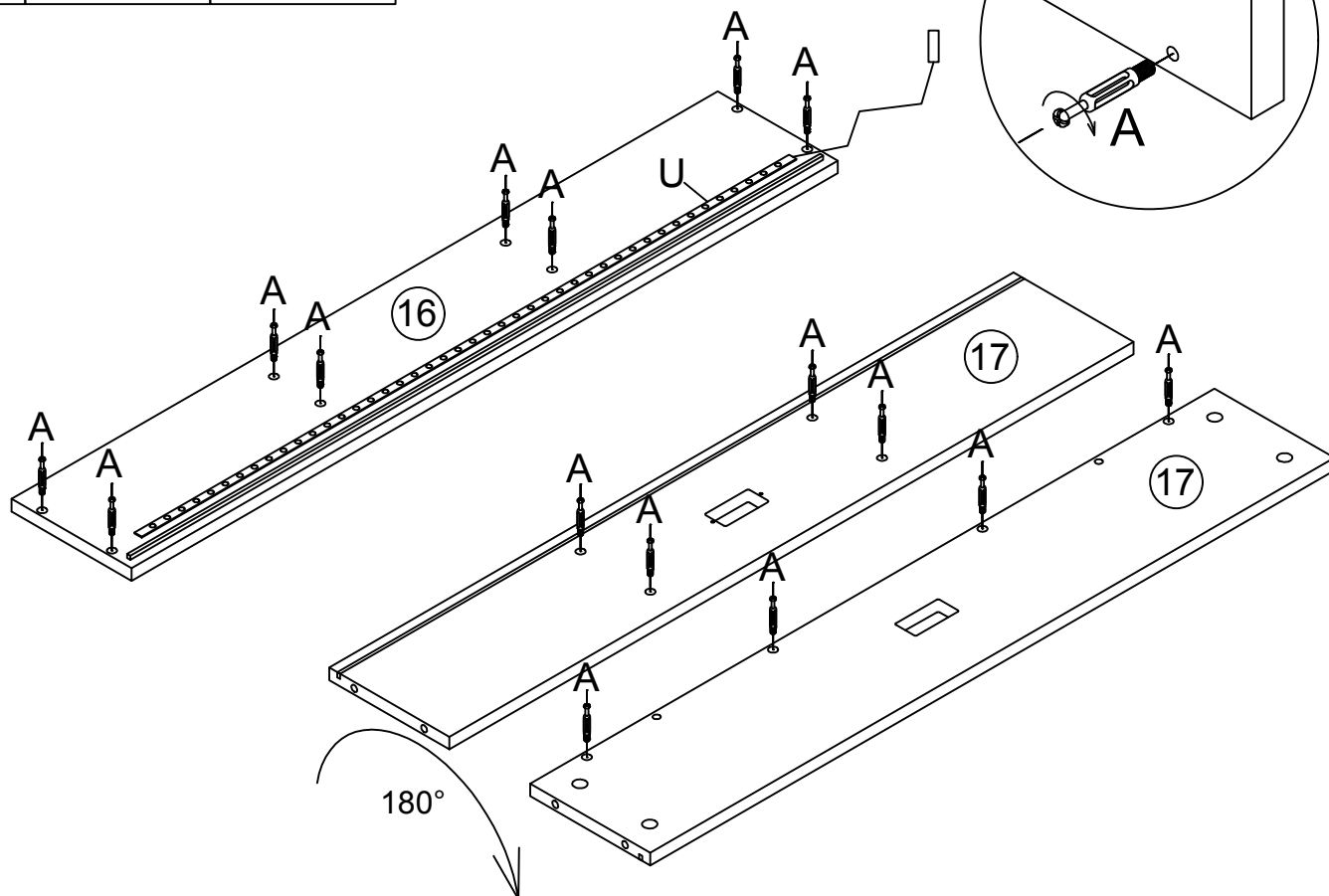

3



A x 8

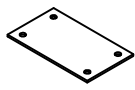

K x 2

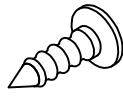

J x 4

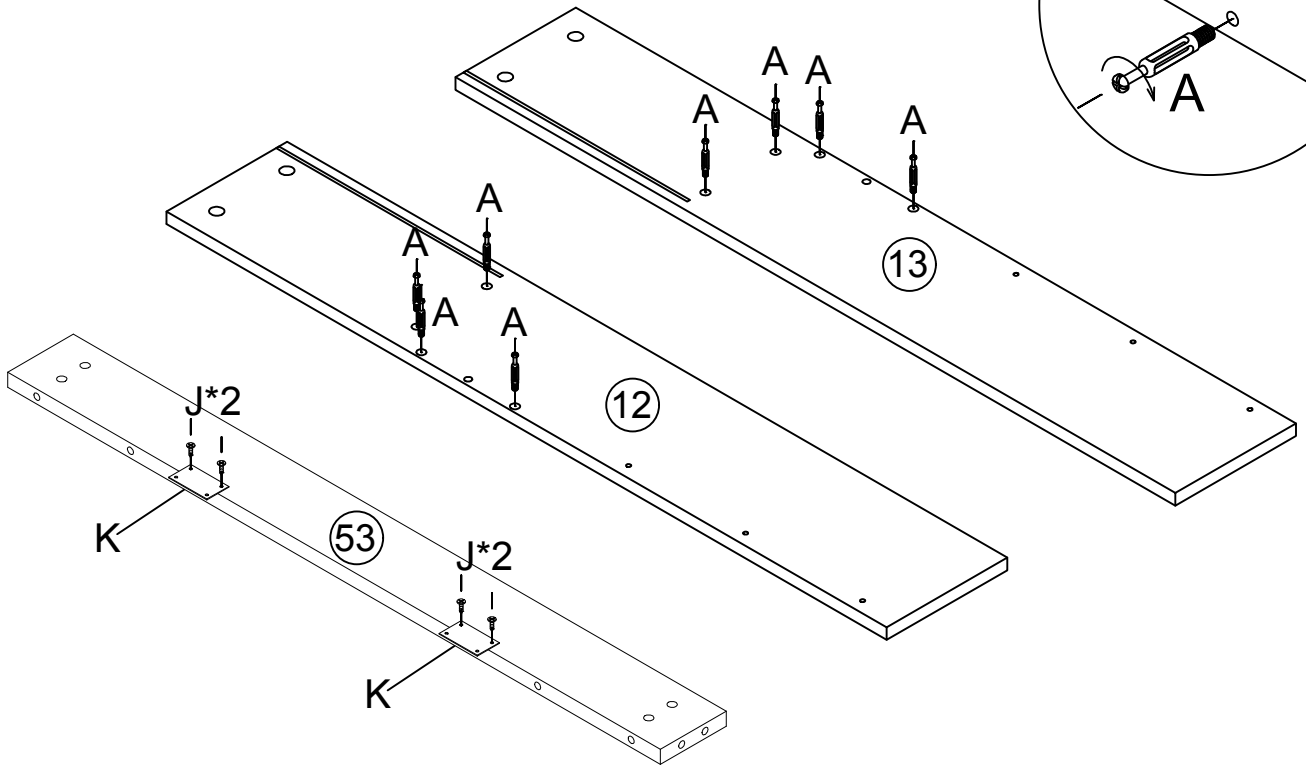

4

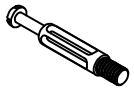

A x 24

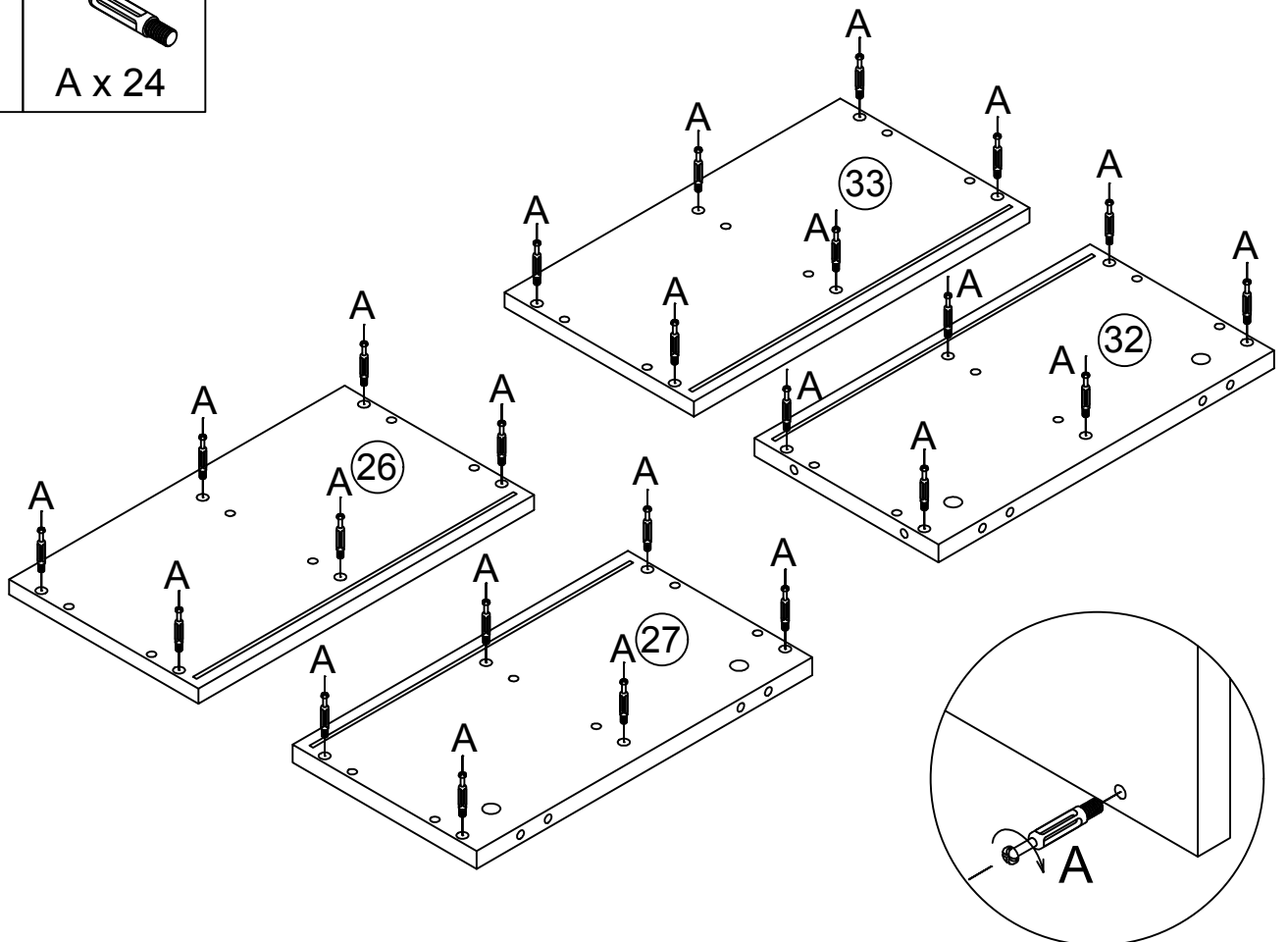

5

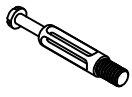

A x 12

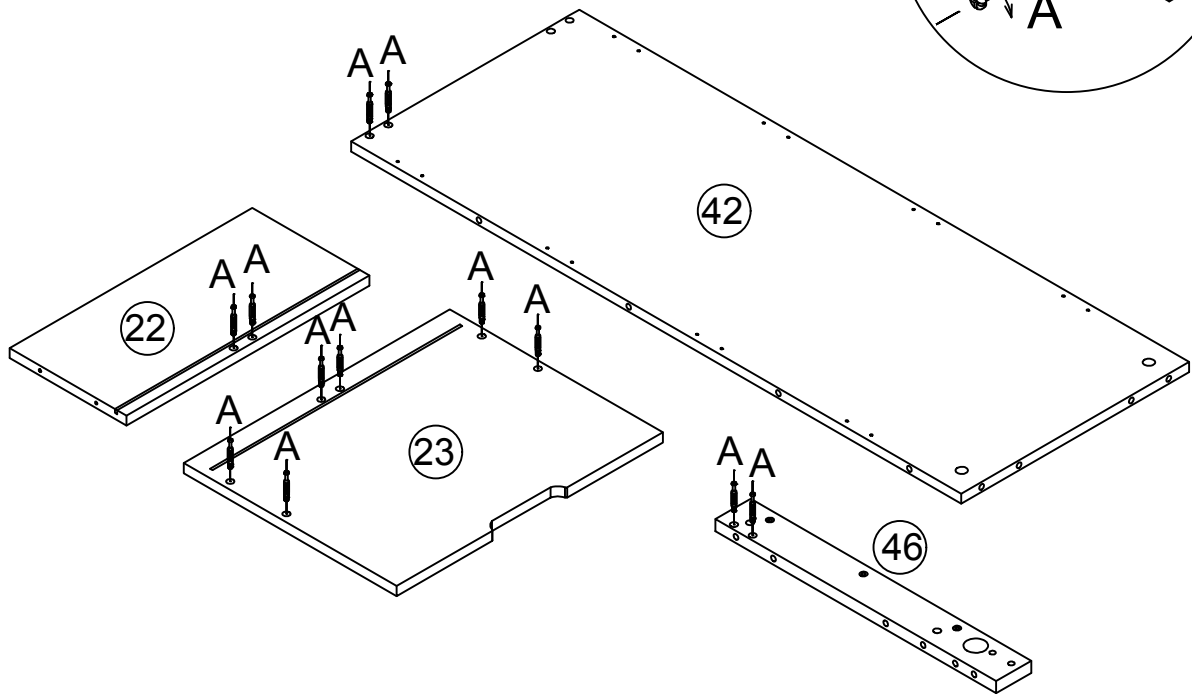

6

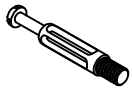

A x 8

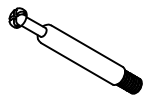

B x 8



L x 8

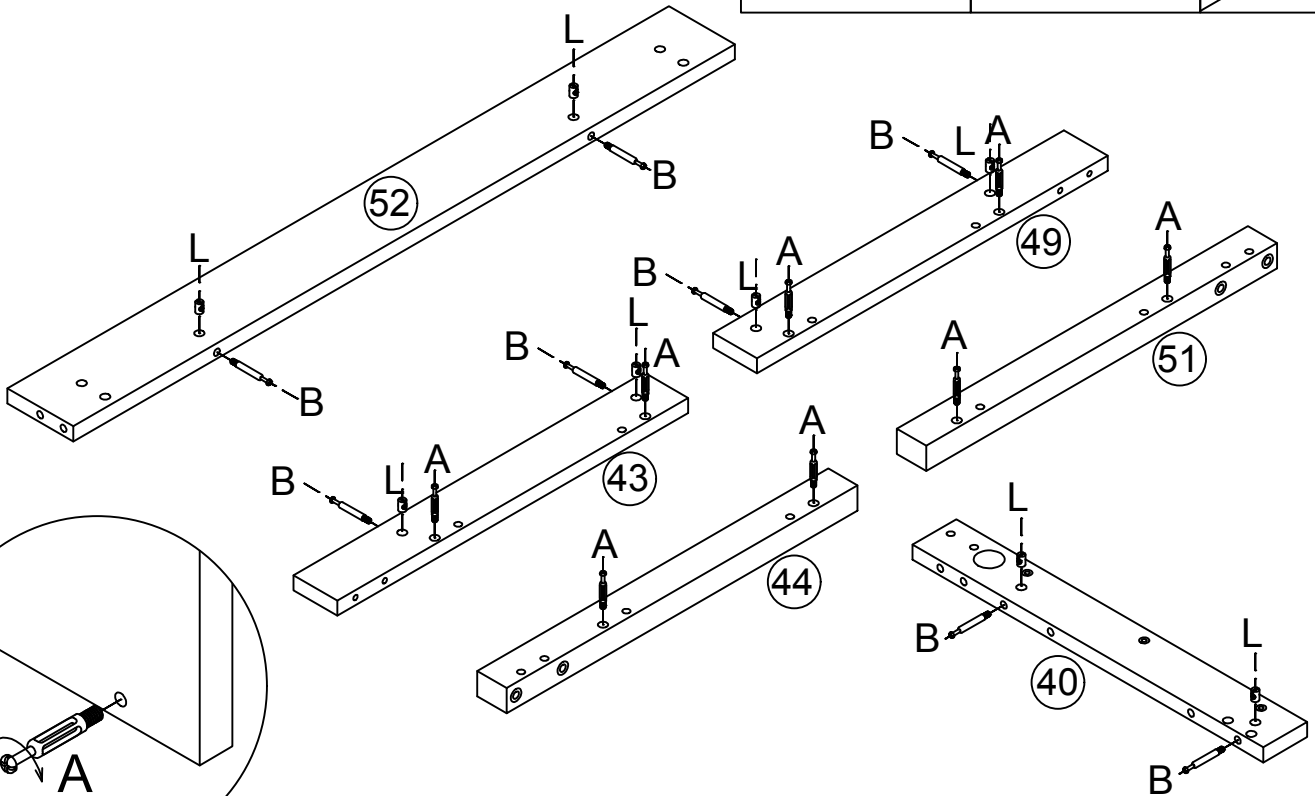
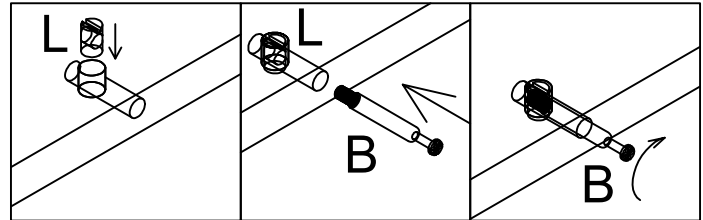

7

D x 2

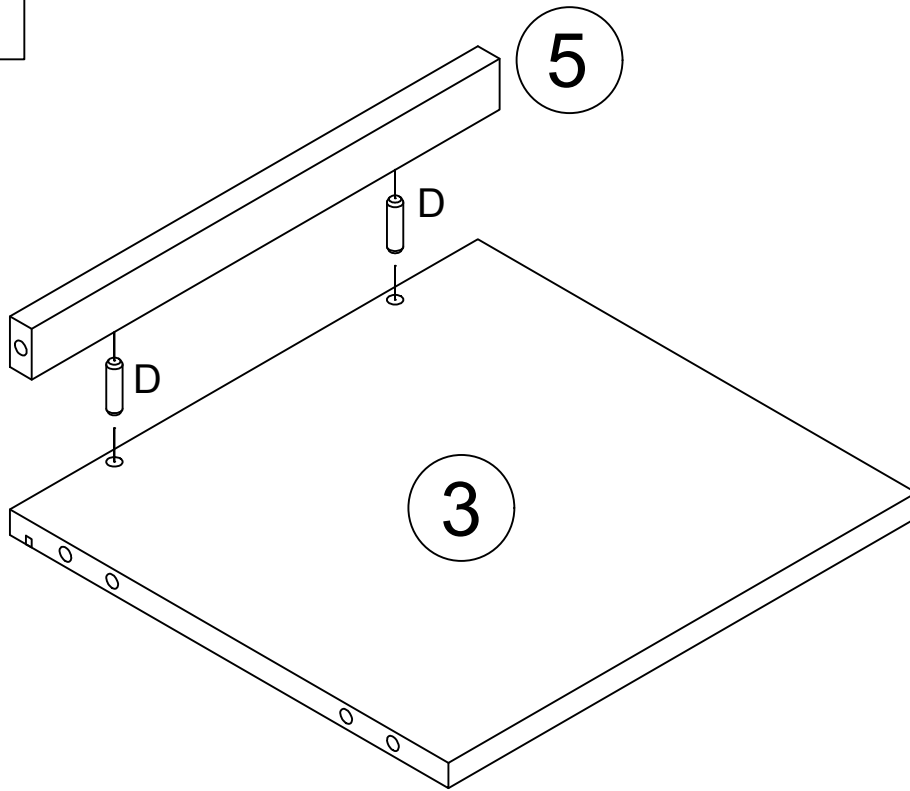

8

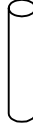

E x 4

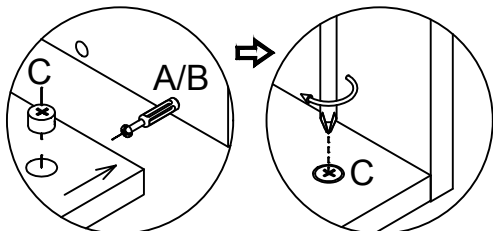
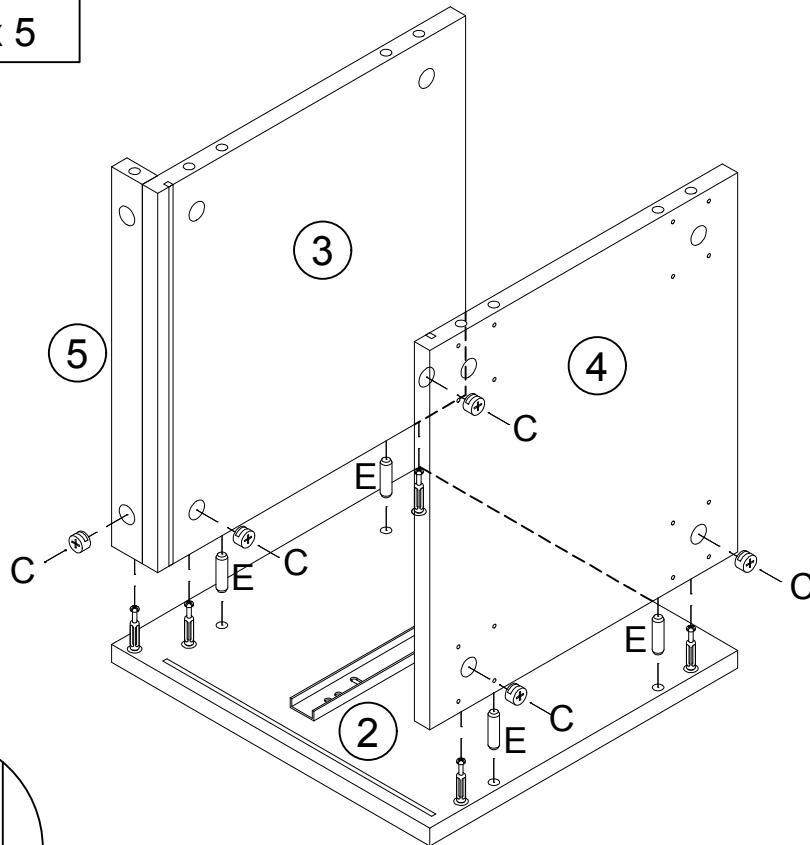

C x 5

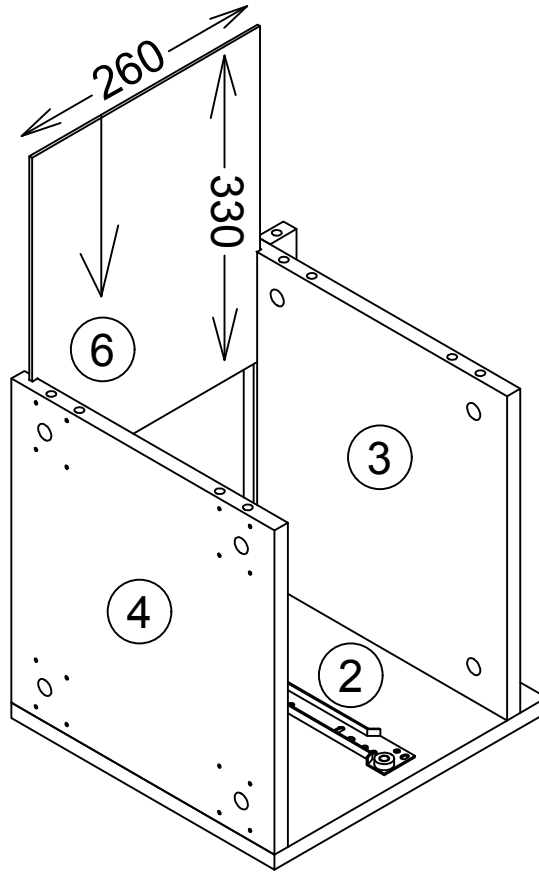

9



10

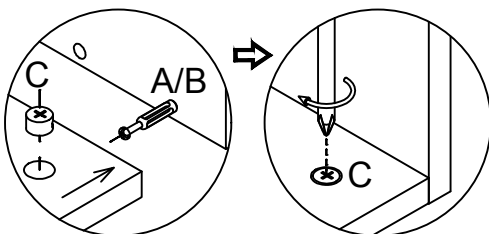
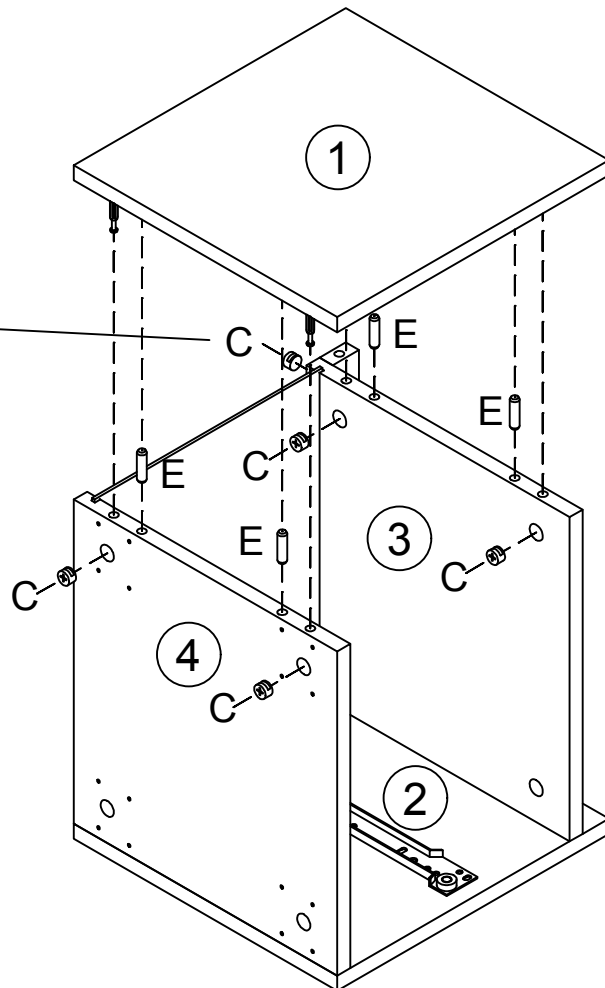
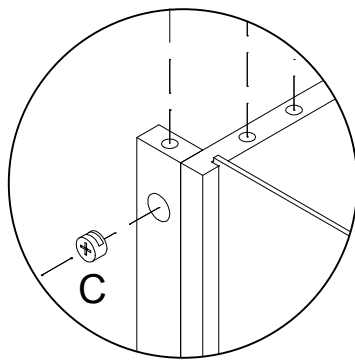
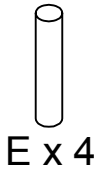

11



M x 2



N x 2

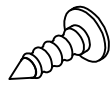

J x 16

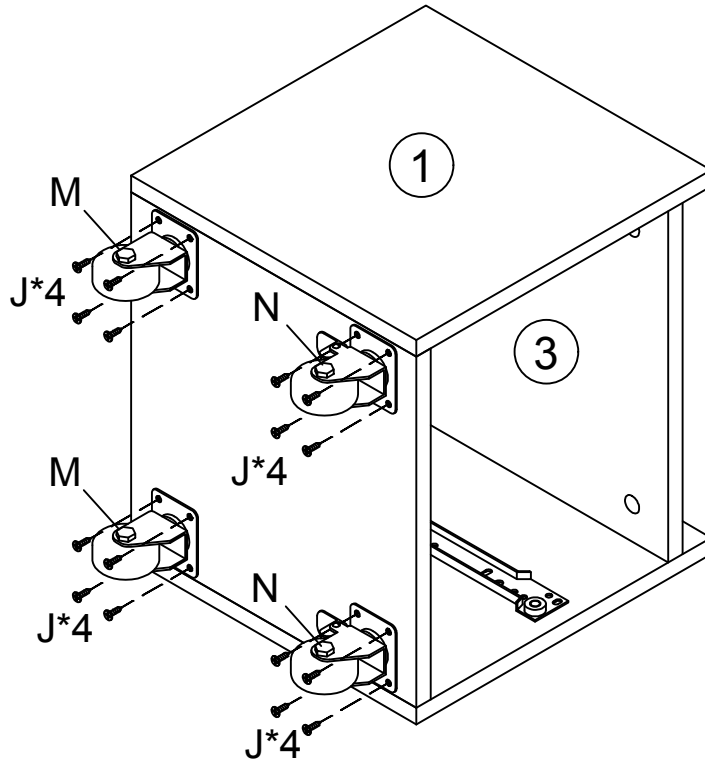

12

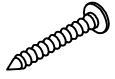

W x 4

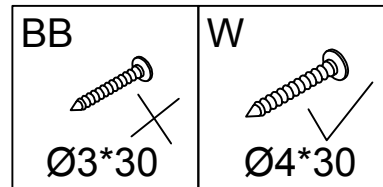
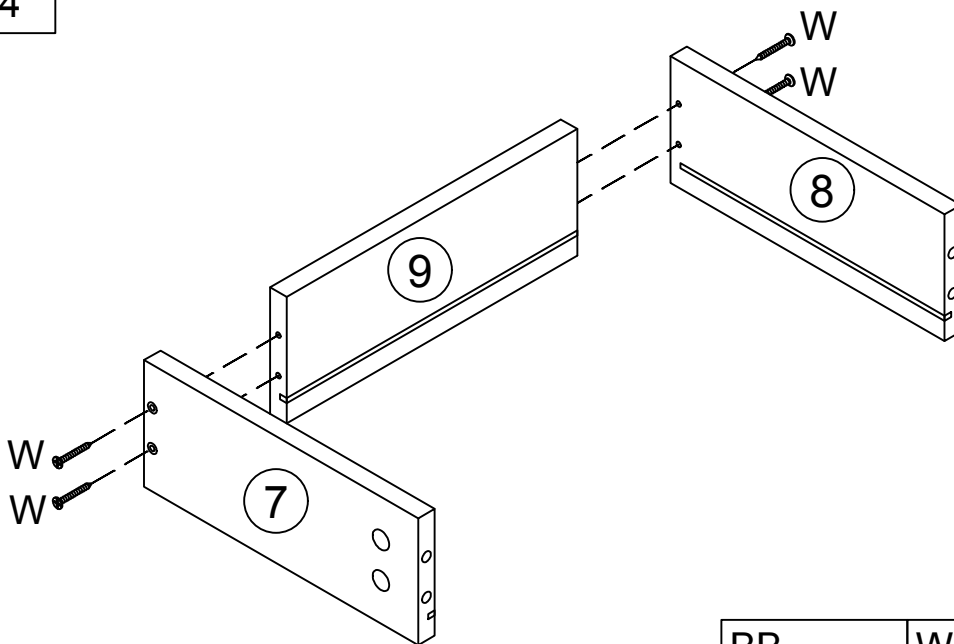

13



C x 4

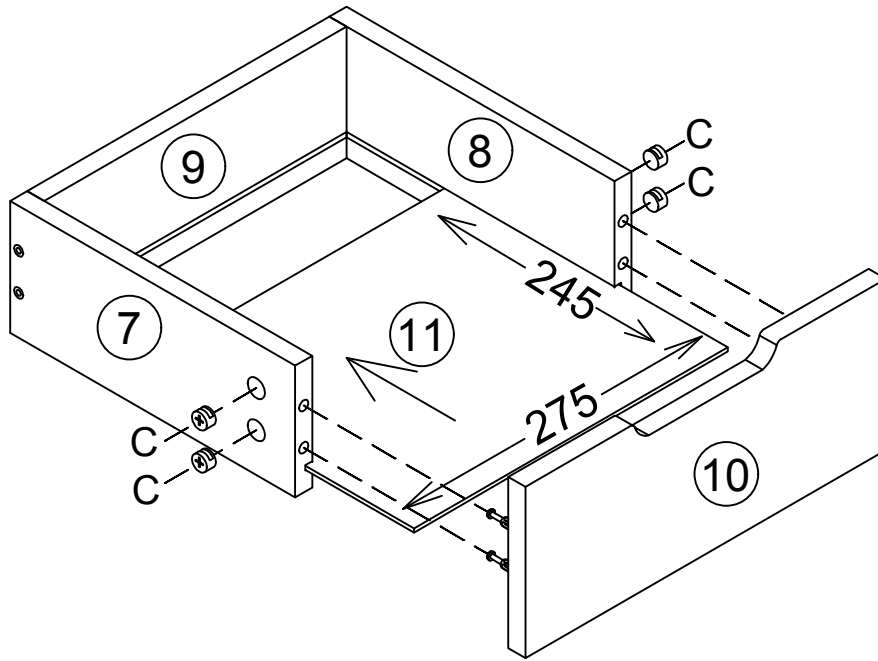
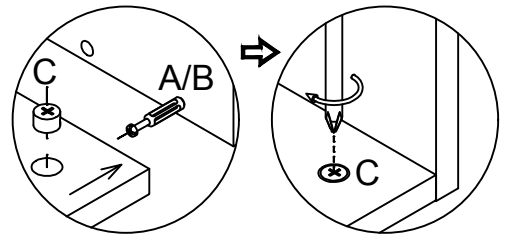

14

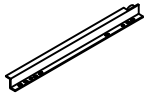

DL x 1

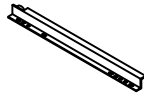

DR x 1

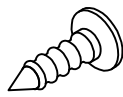

J x 4

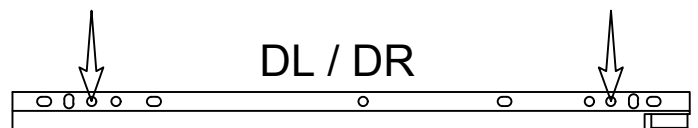
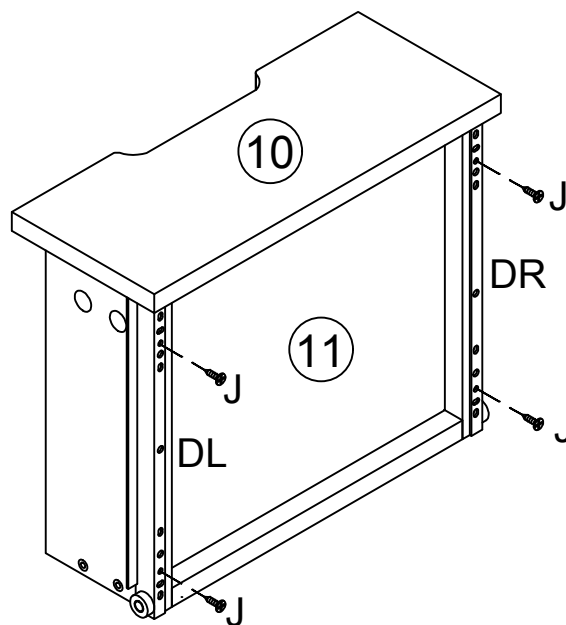

15

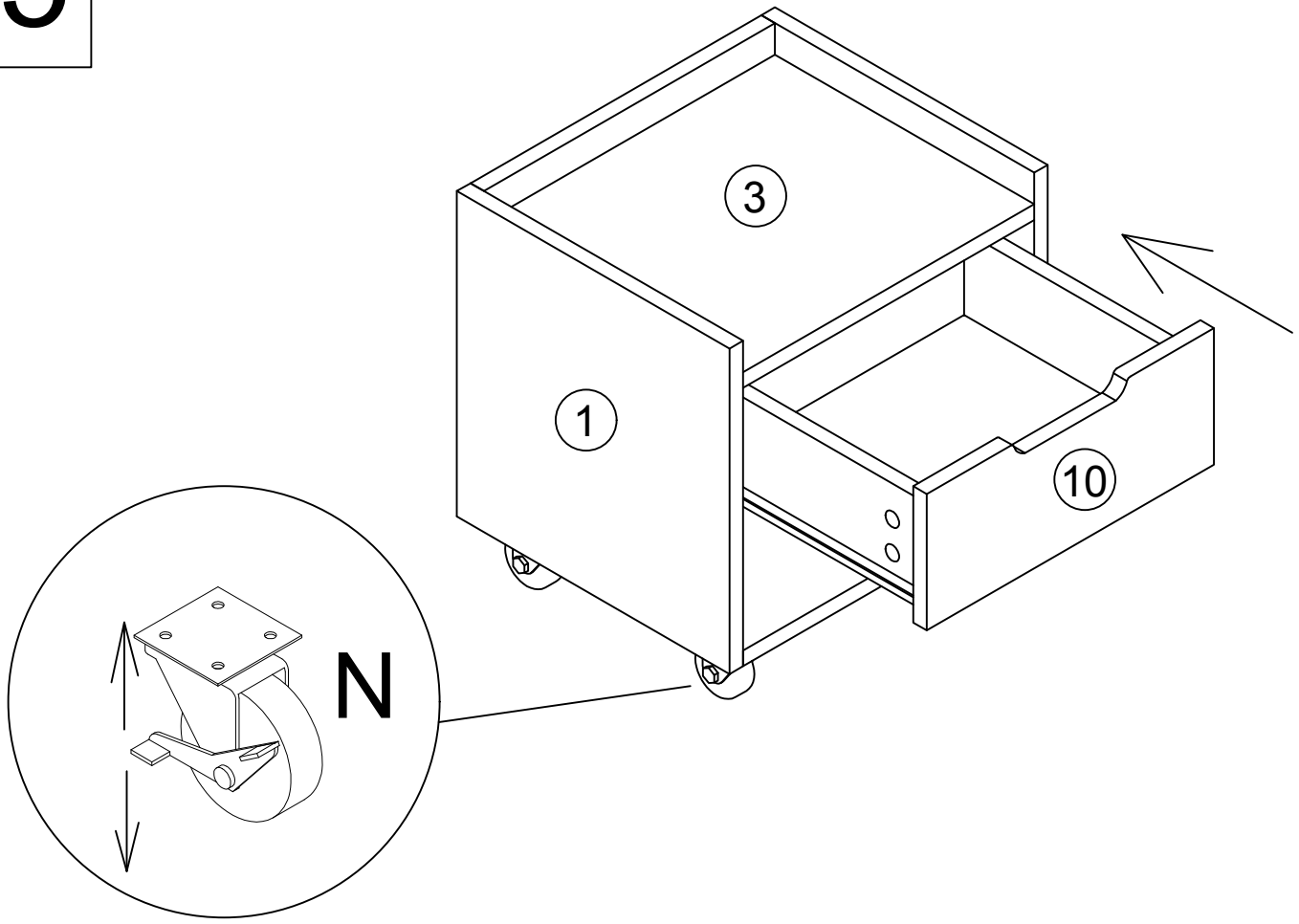

16

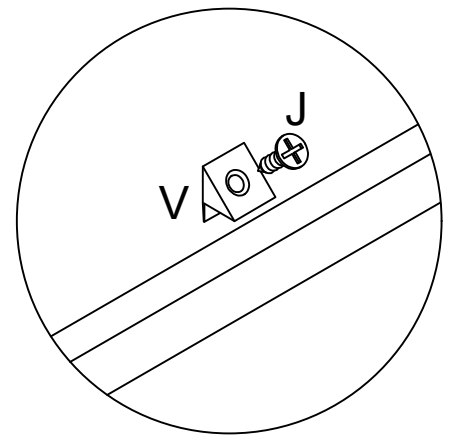
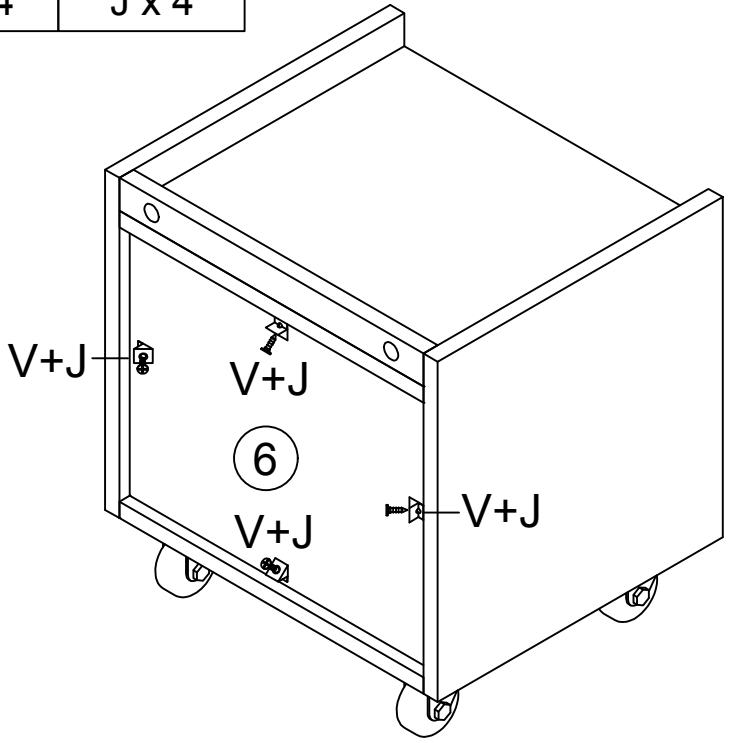
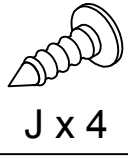

17



C x 4

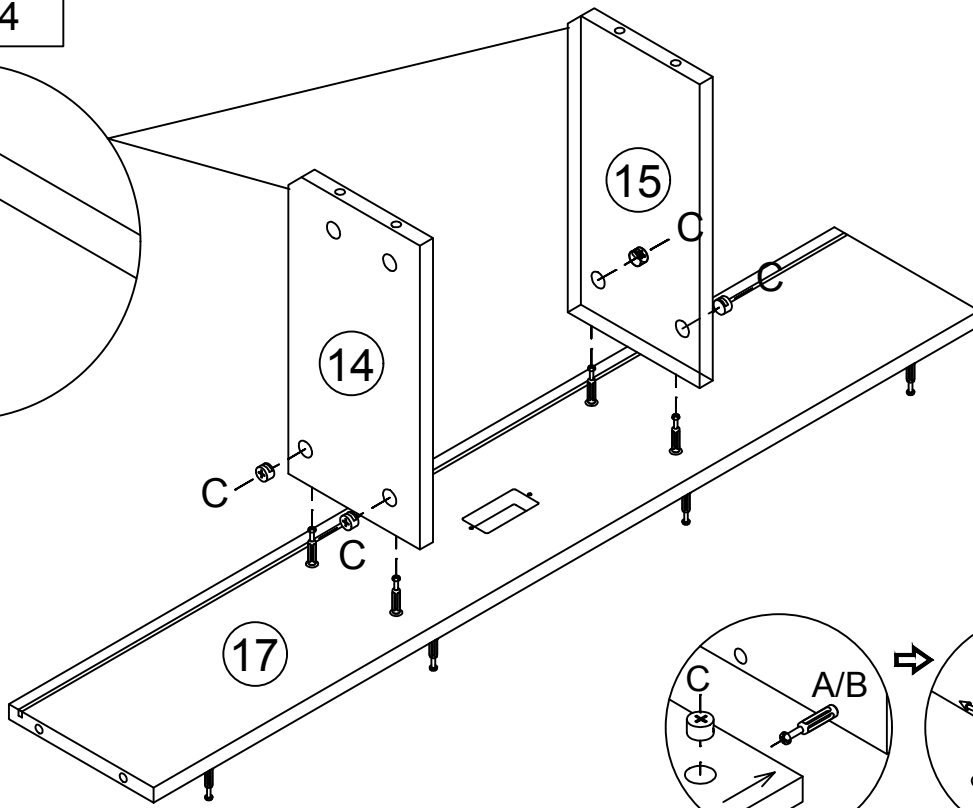
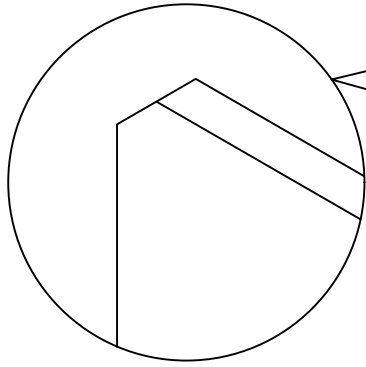

18



E x 2



C x 4

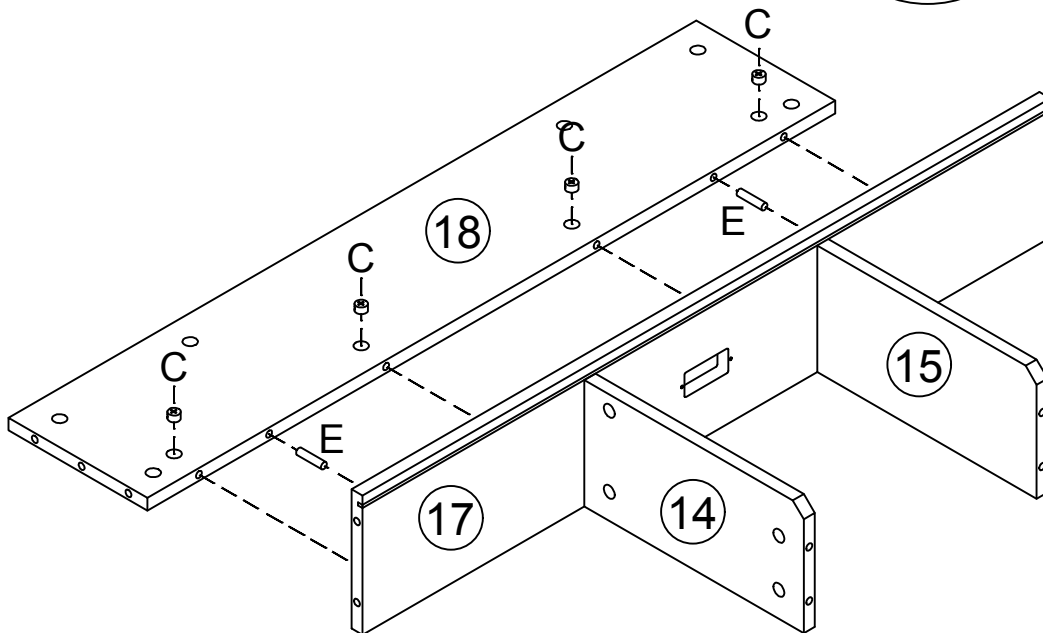
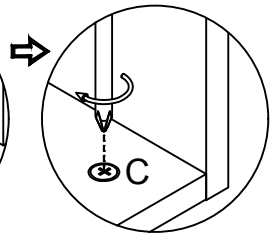
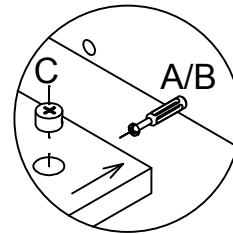

19

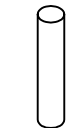

E x 2



C x 8

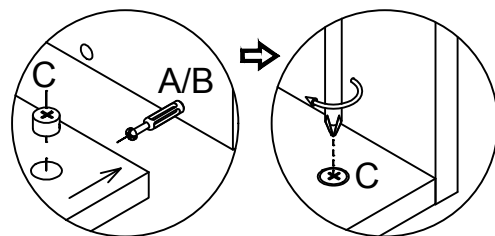
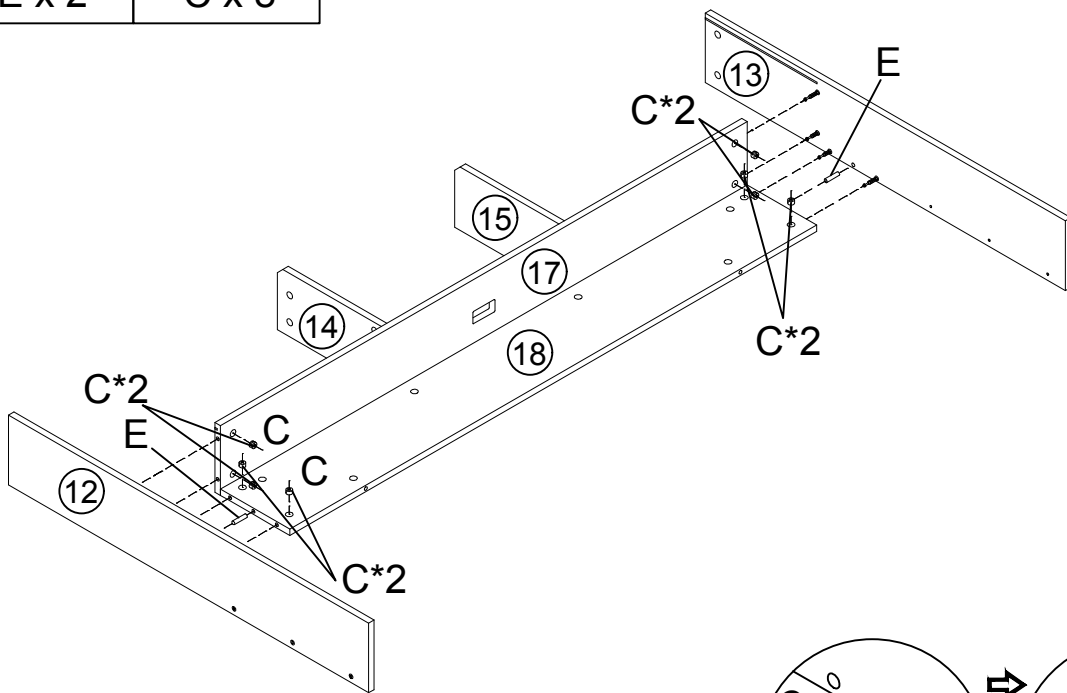

20

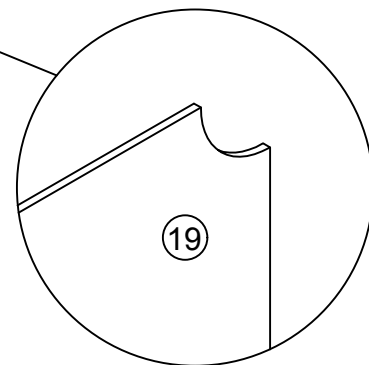
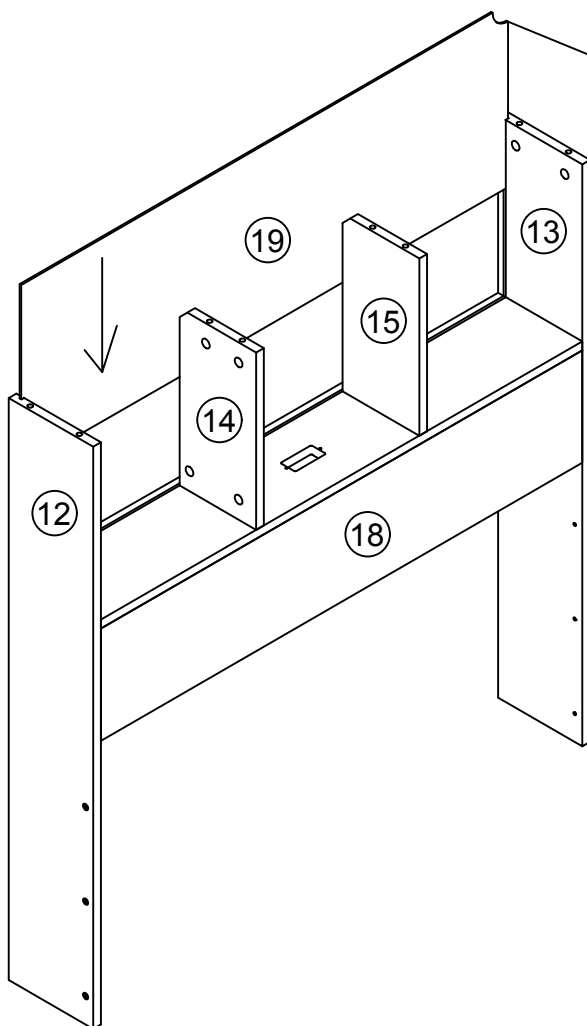

21



C x 8

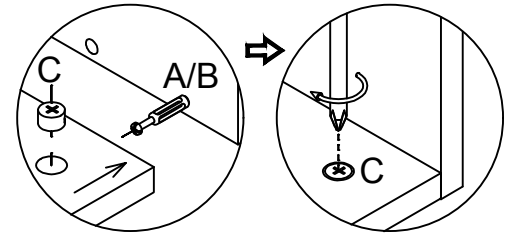
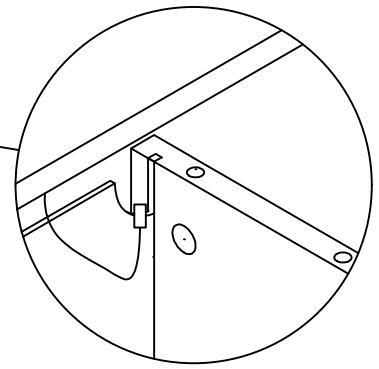
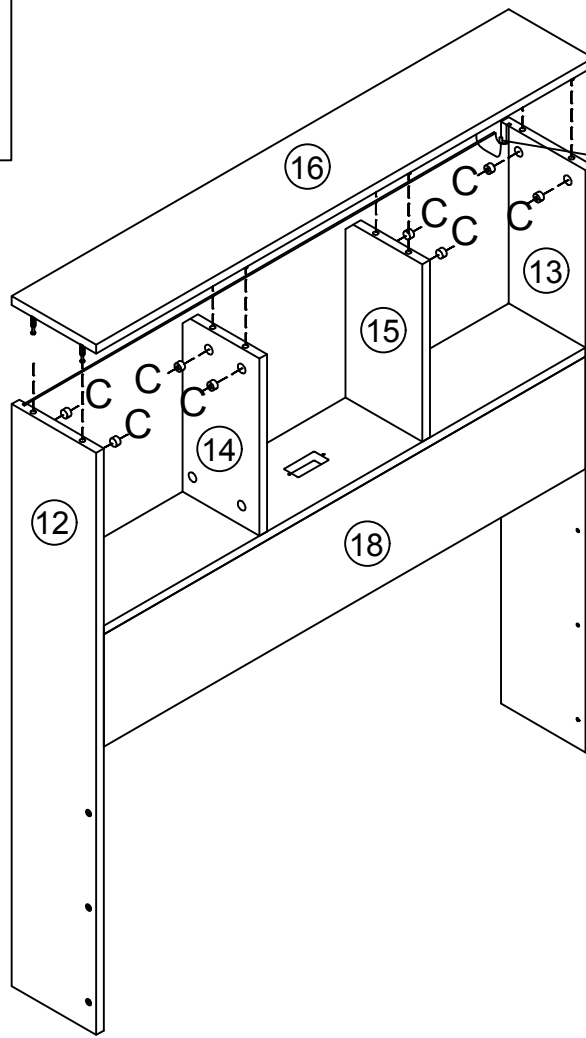

22



C x 2

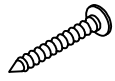

W x 4

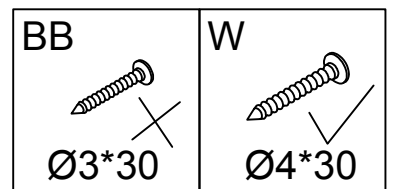
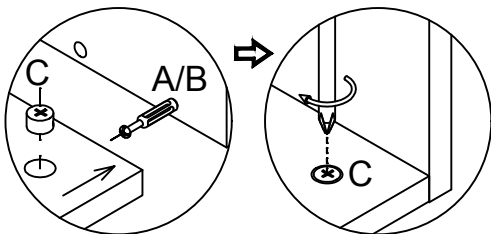
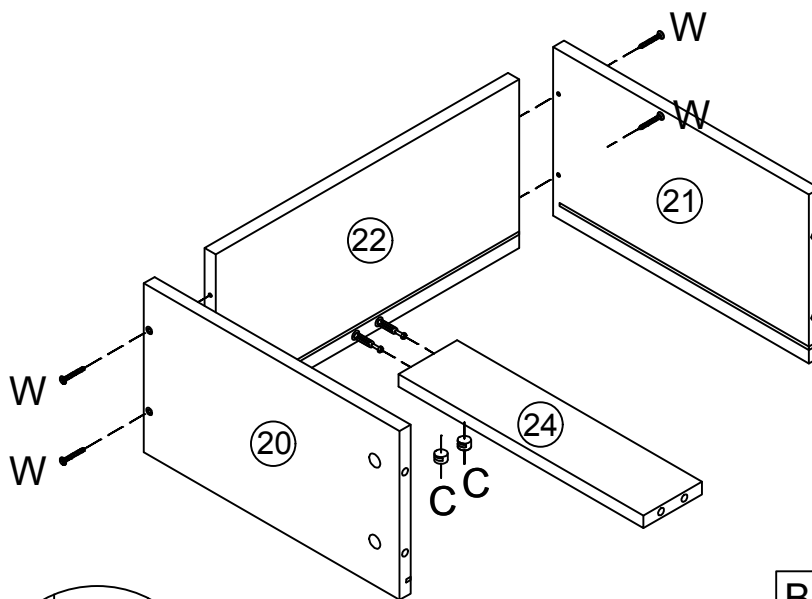

23

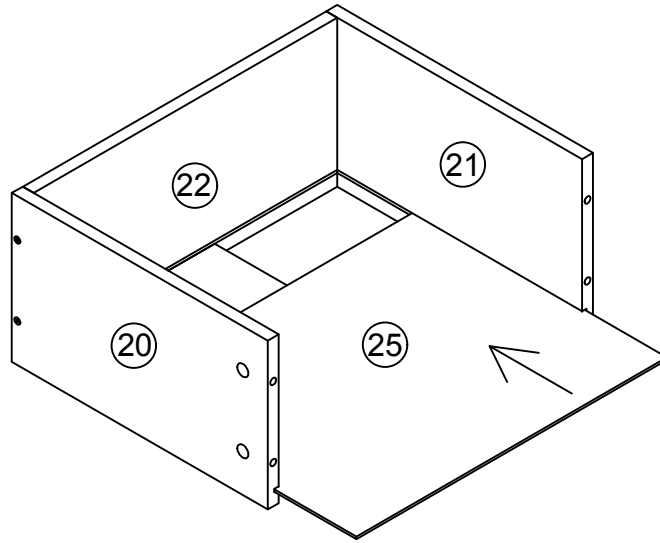

24



C x 6

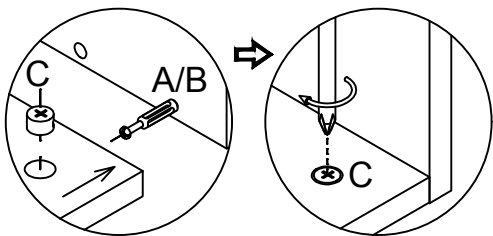
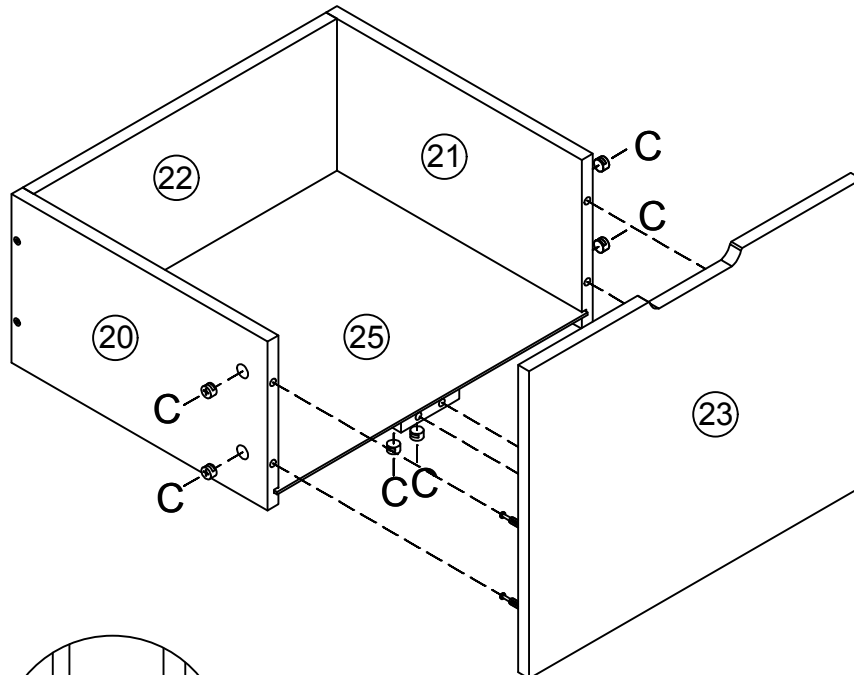

25



P x 4

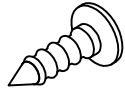

J x 8

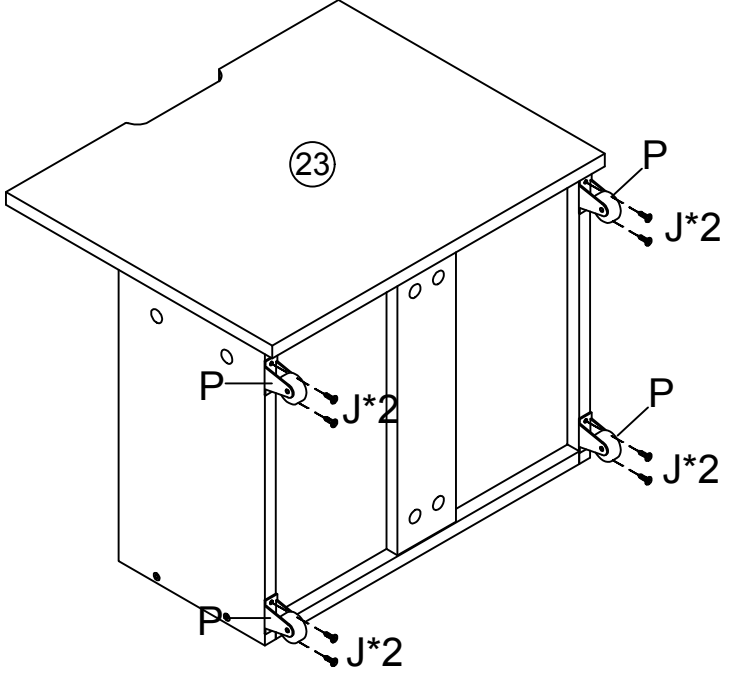

26



E x 6



C x 6

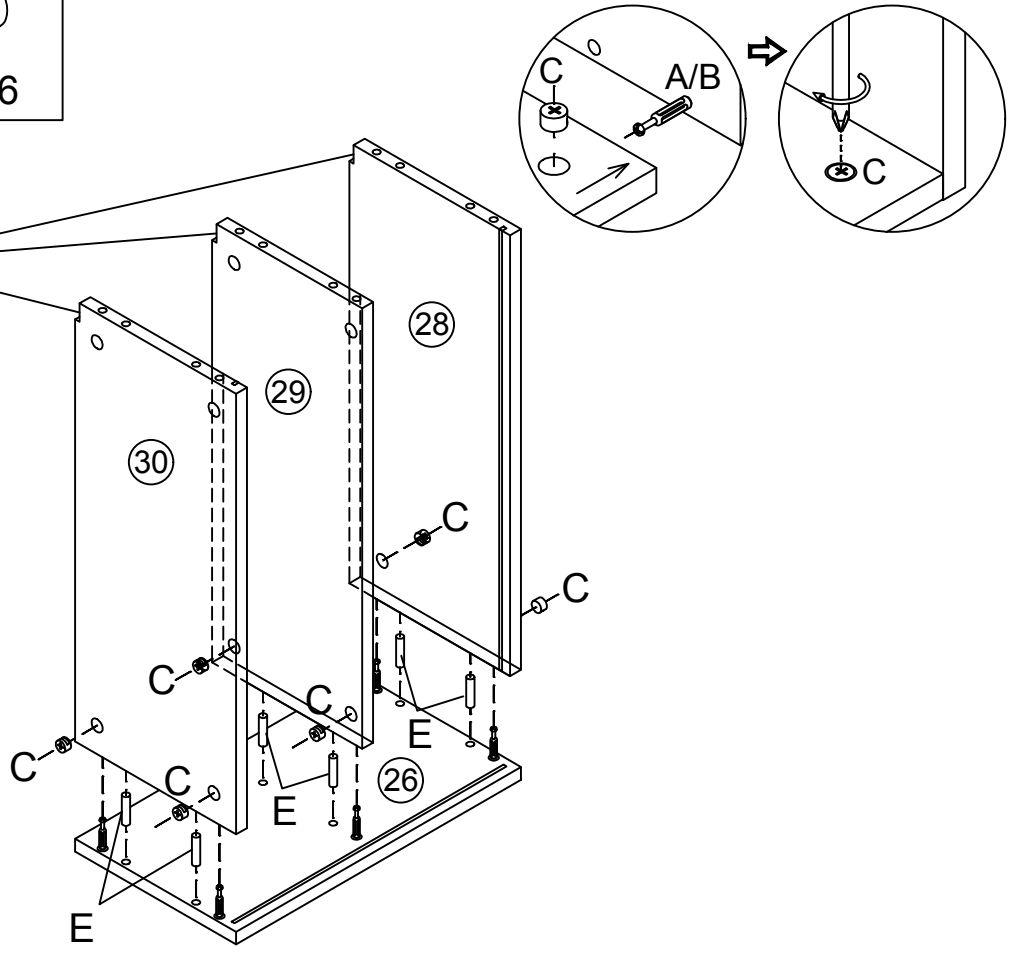
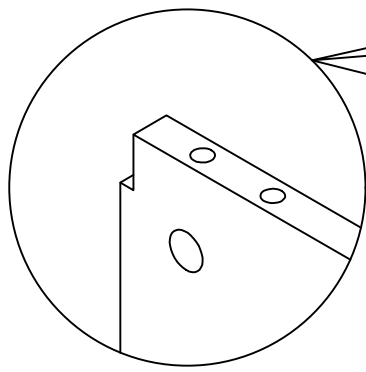

27

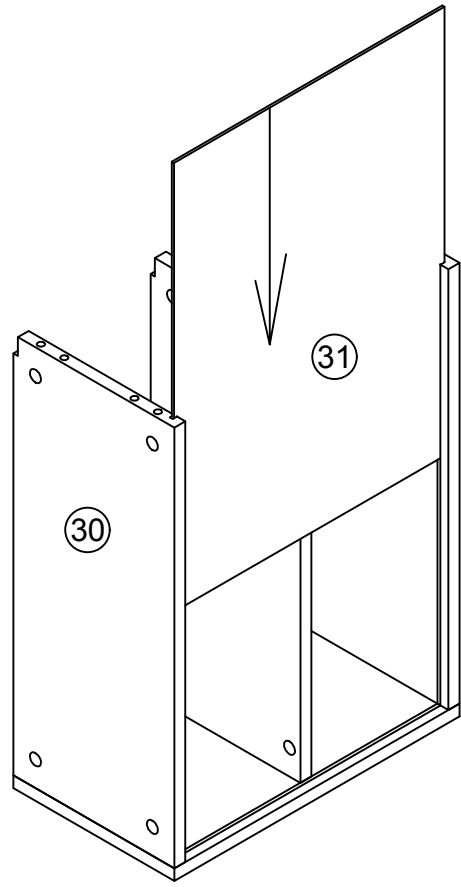

28

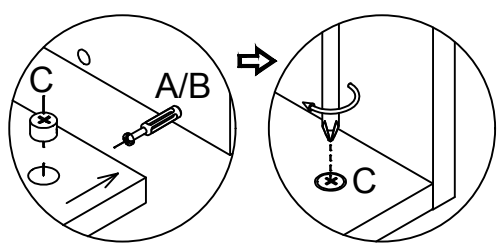
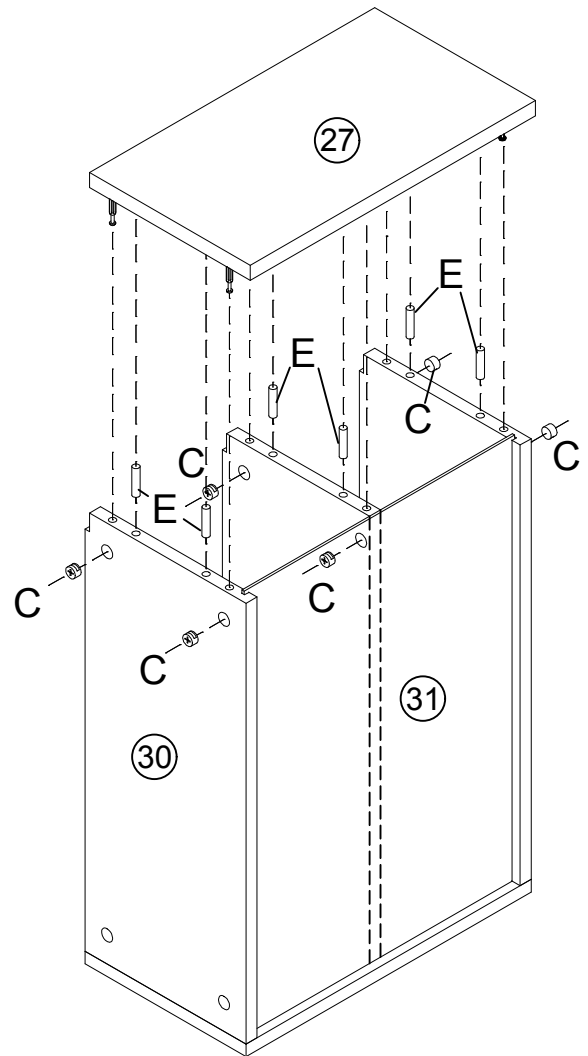

29



V x 4

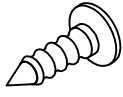

J x 4

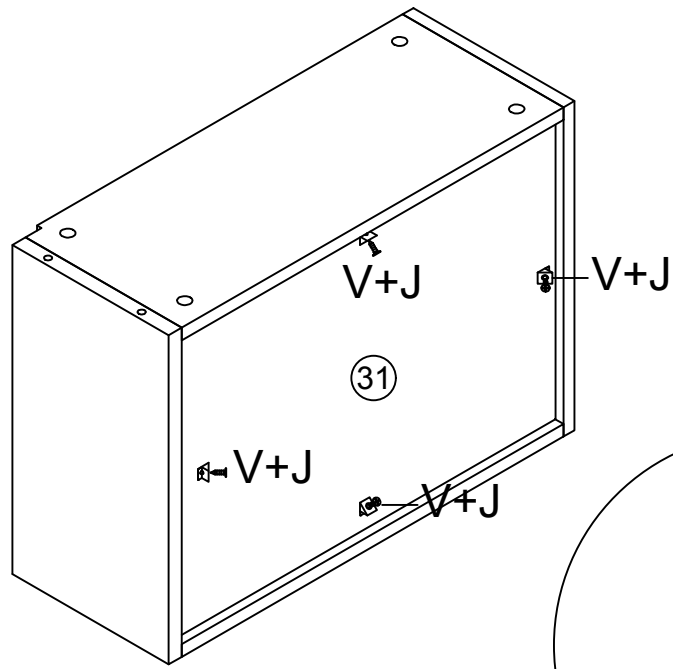

30



E x 6



C x 6

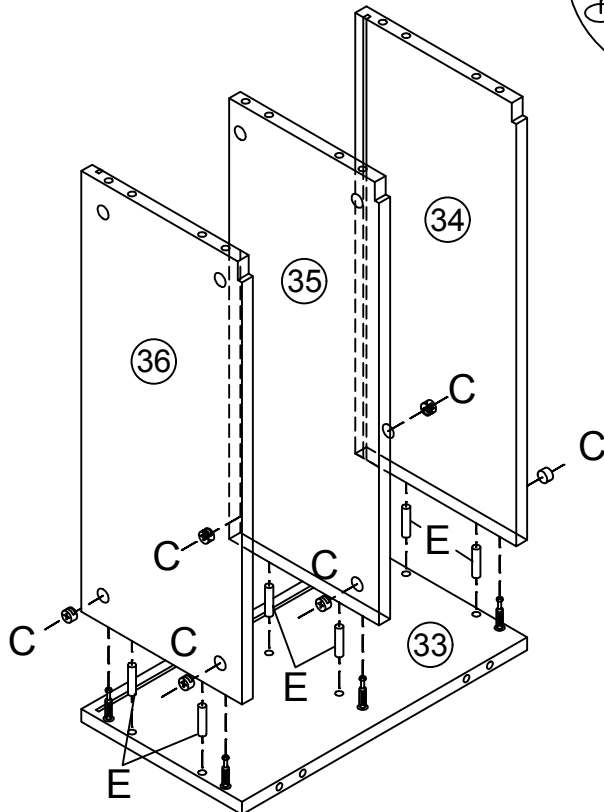

31

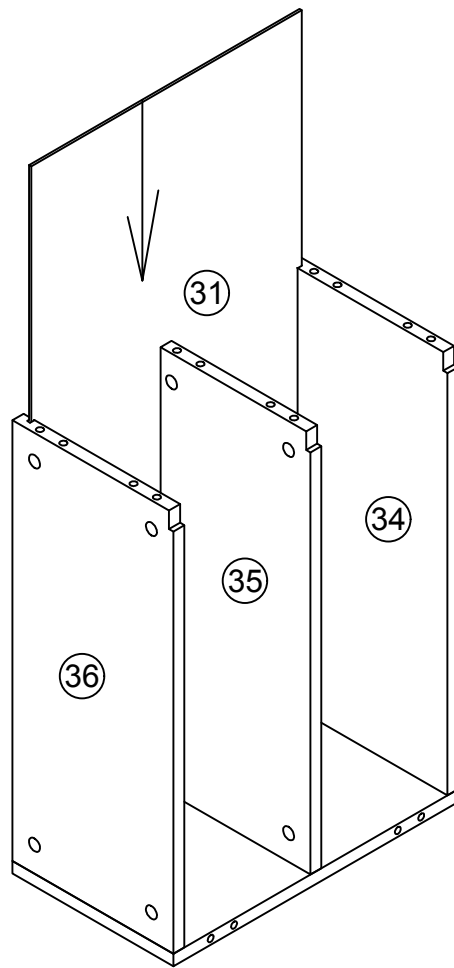

32

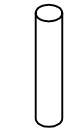

E x 6



C x 6

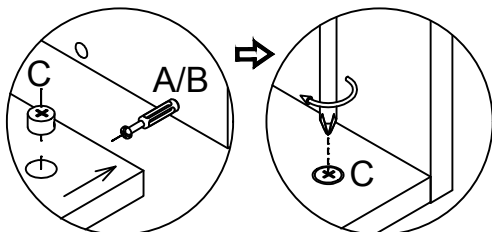
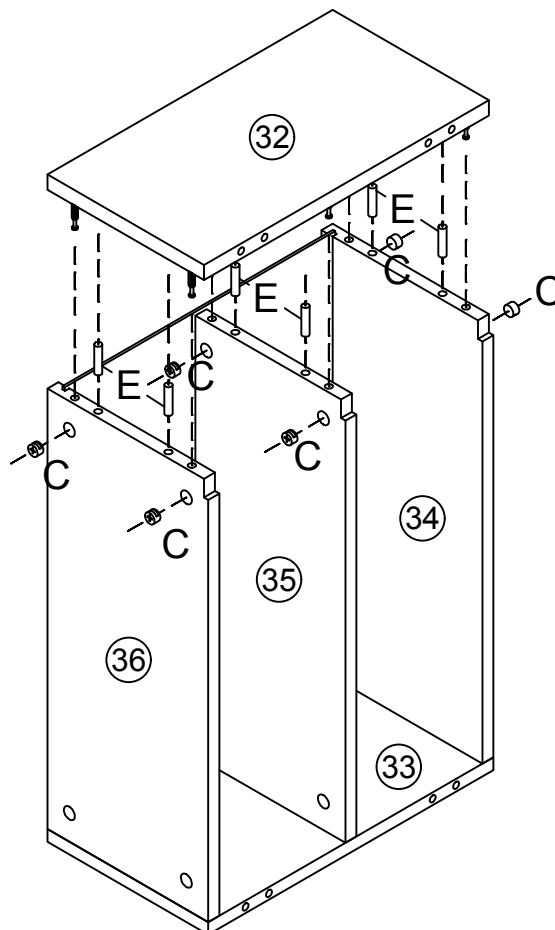

33

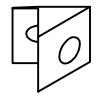

V x 4

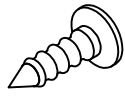

J x 4

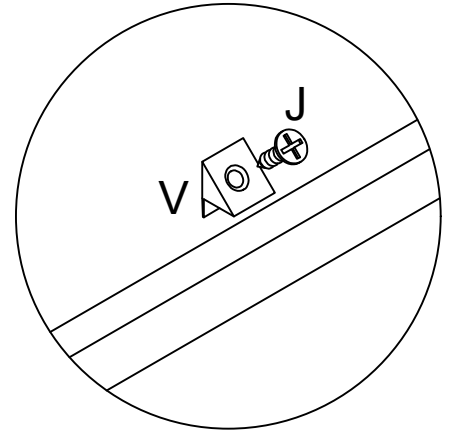
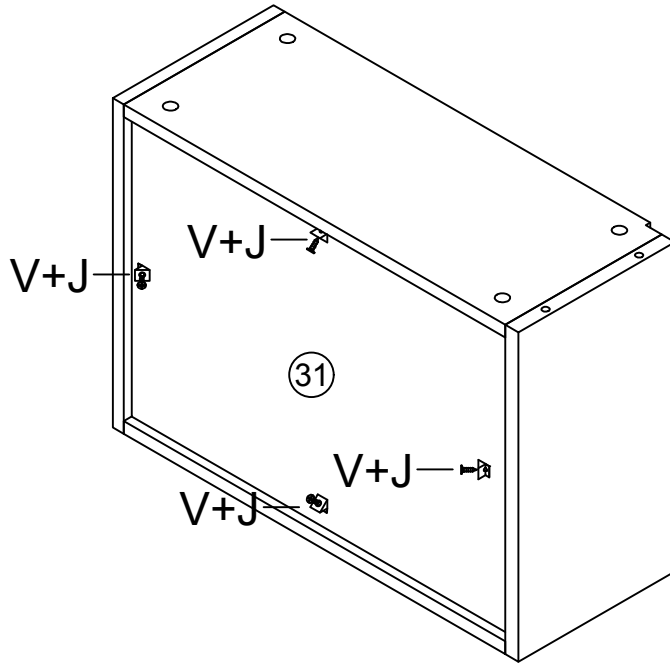

34



G x 4

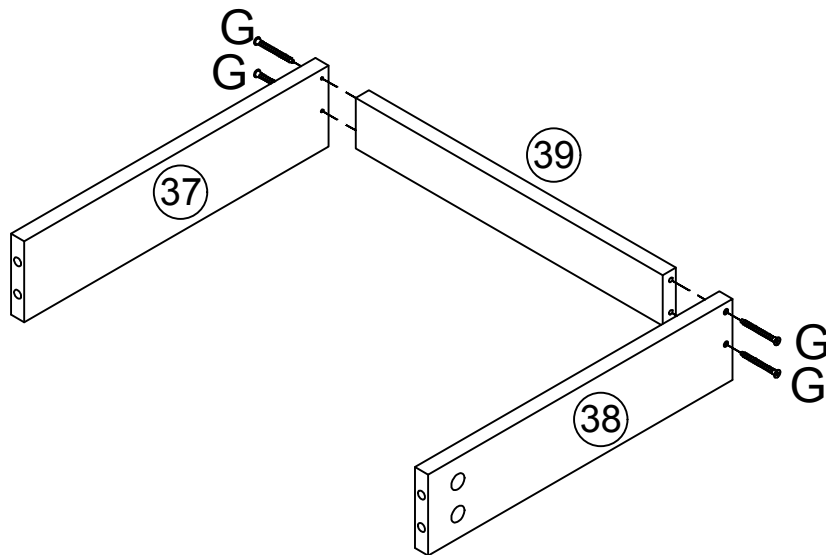

35



E x 6

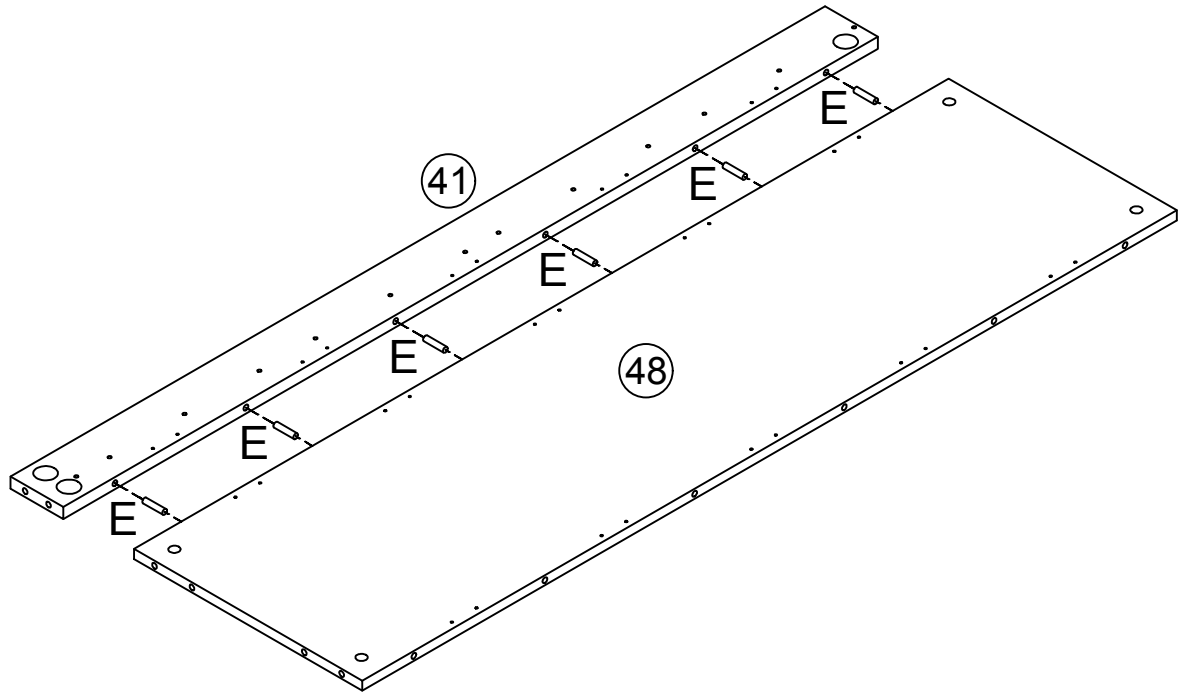

36

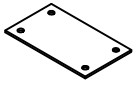

K x 5

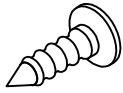

J x 20

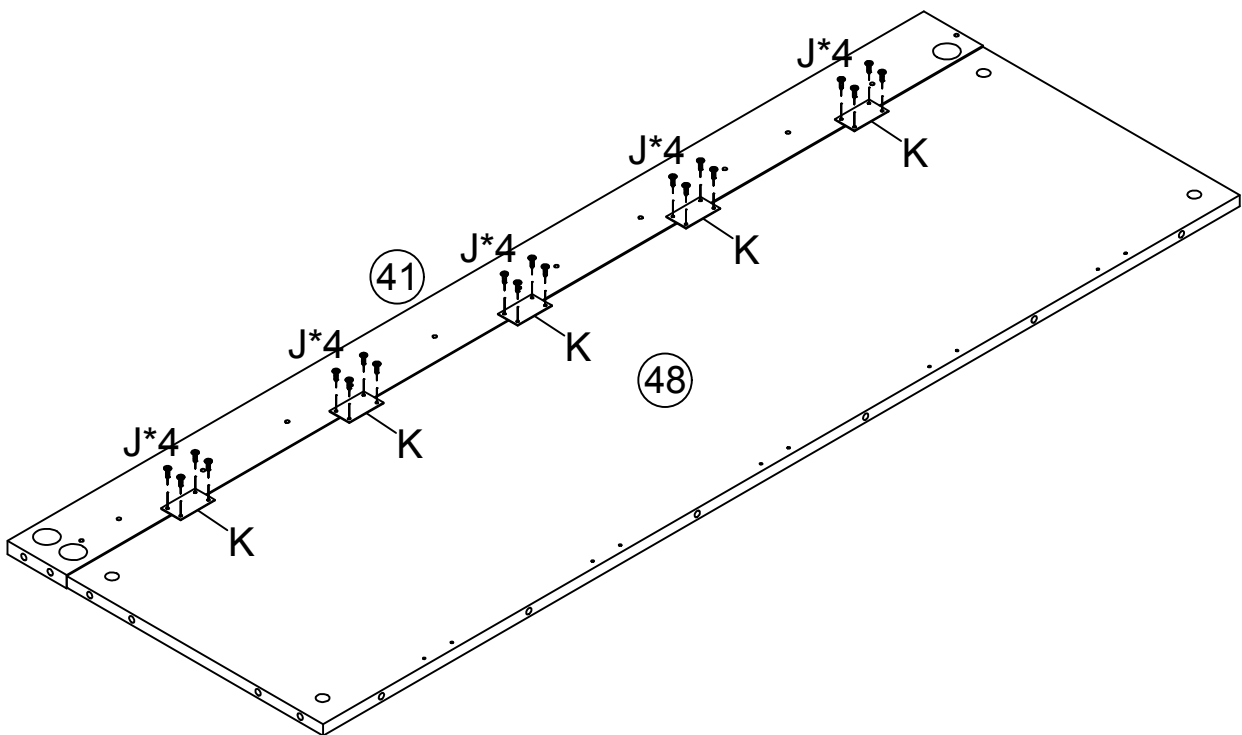

37



E x 4

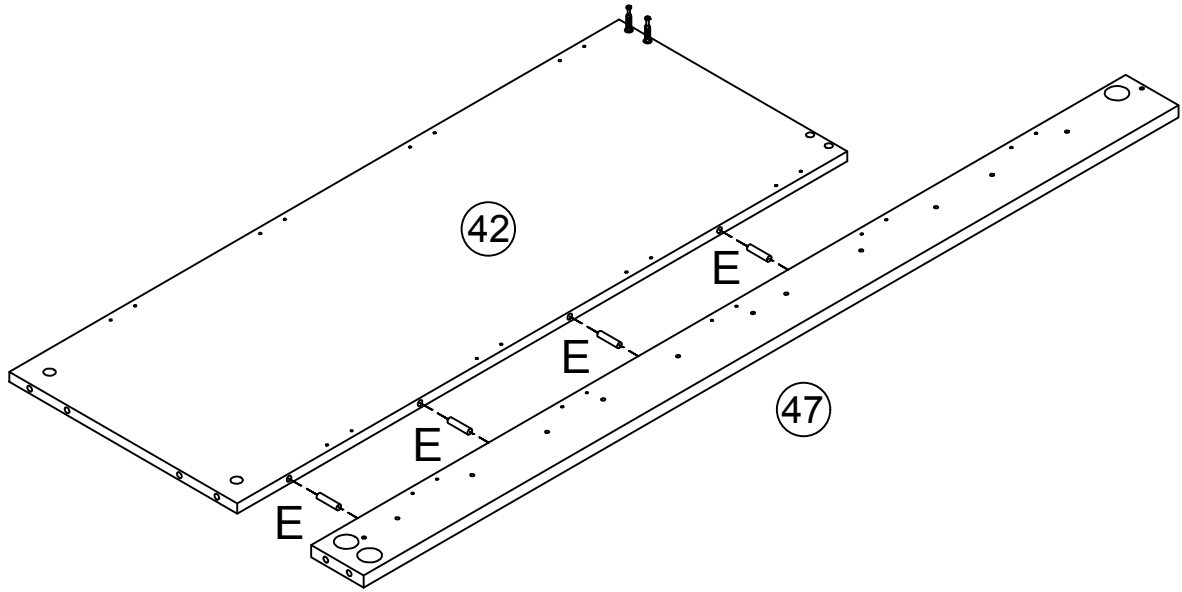

38

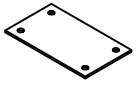

K x 4

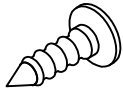

J x 16

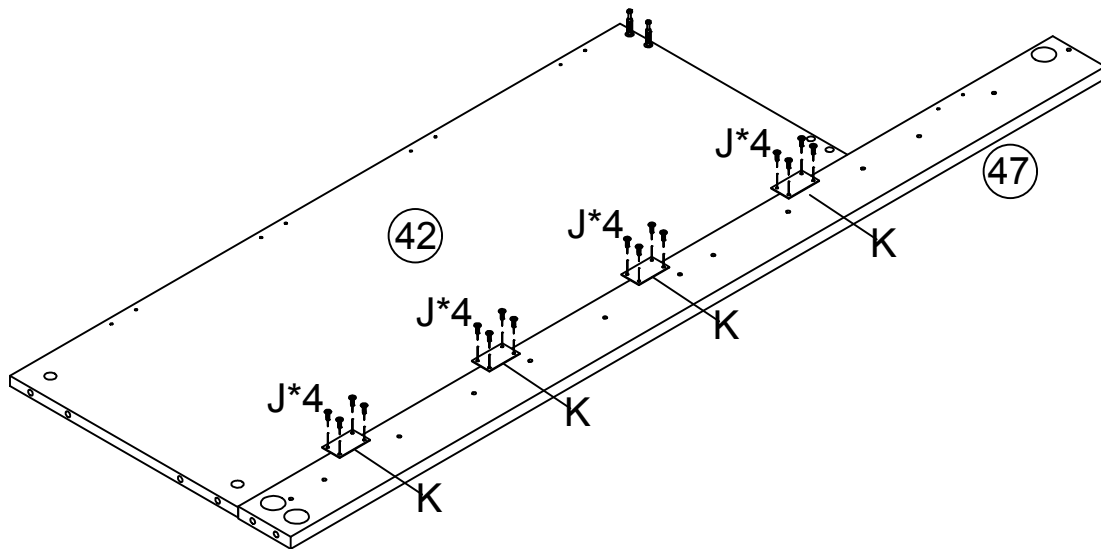

39



E x 1

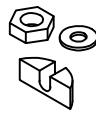

F x 2



T x 1

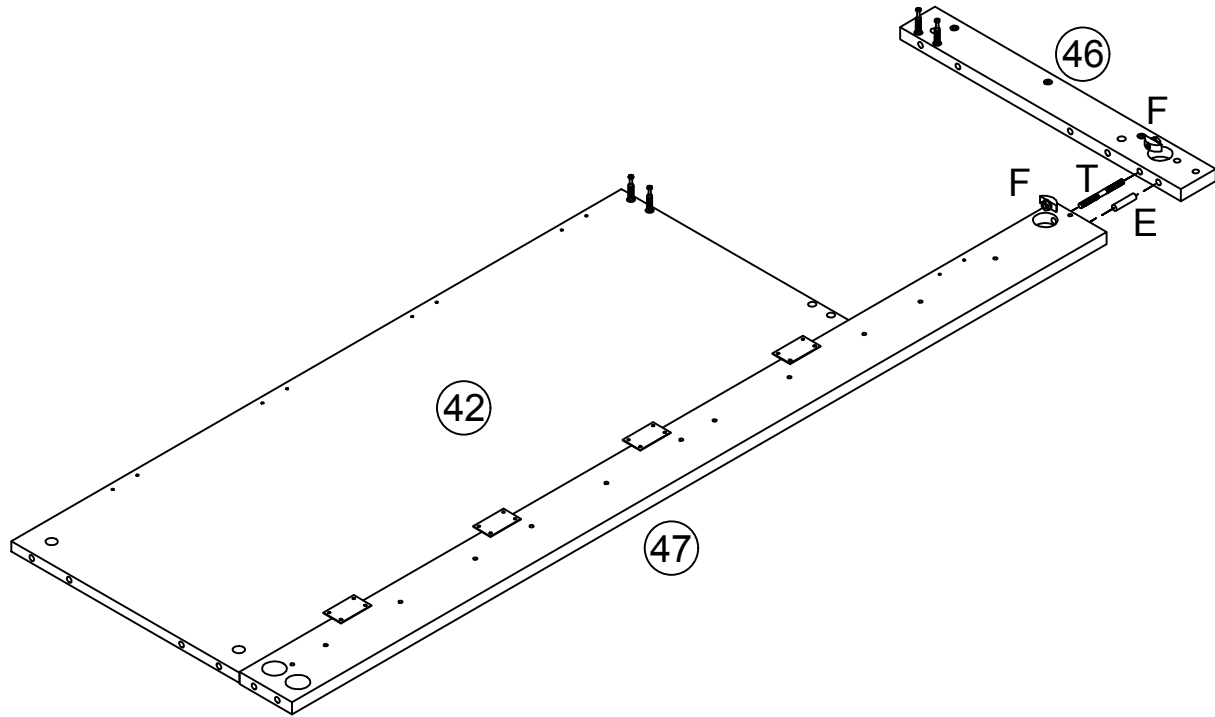
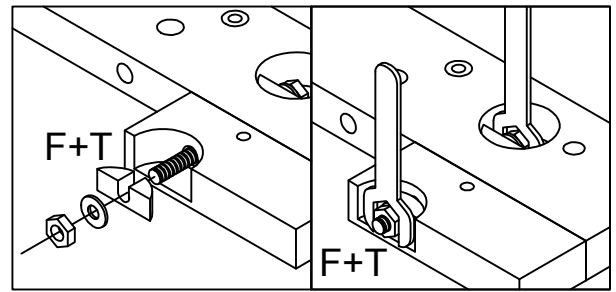

40



E x 2

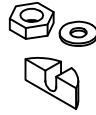

F x 4



S x 2



C x 2

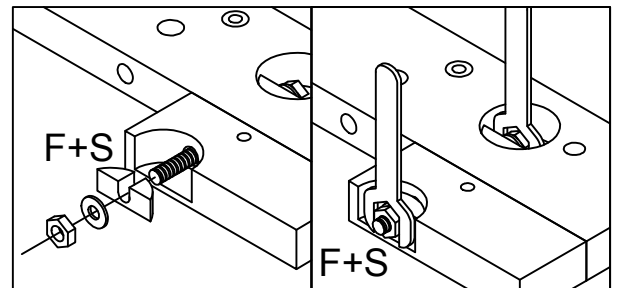
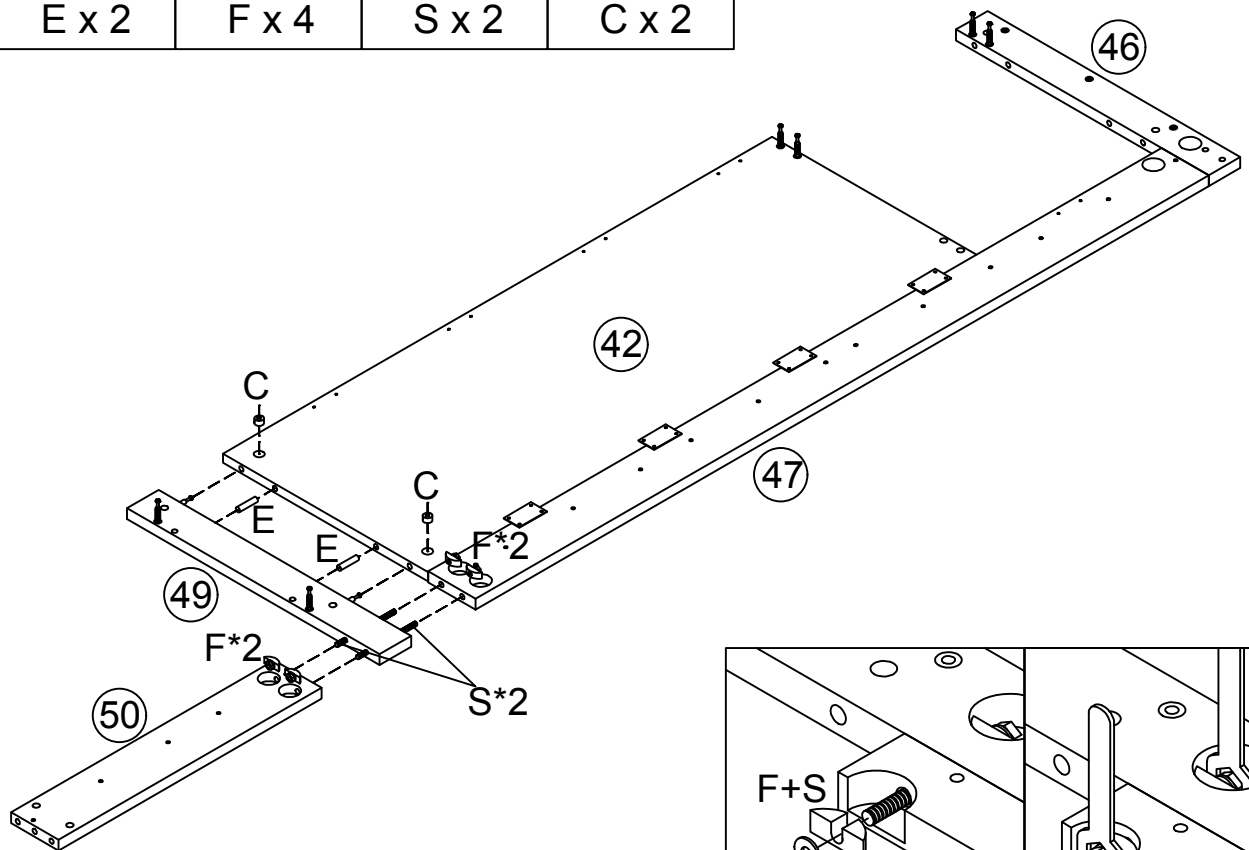

41

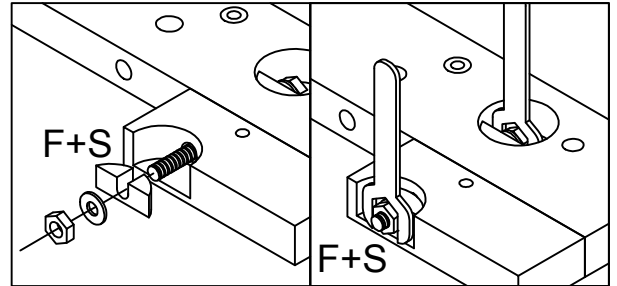
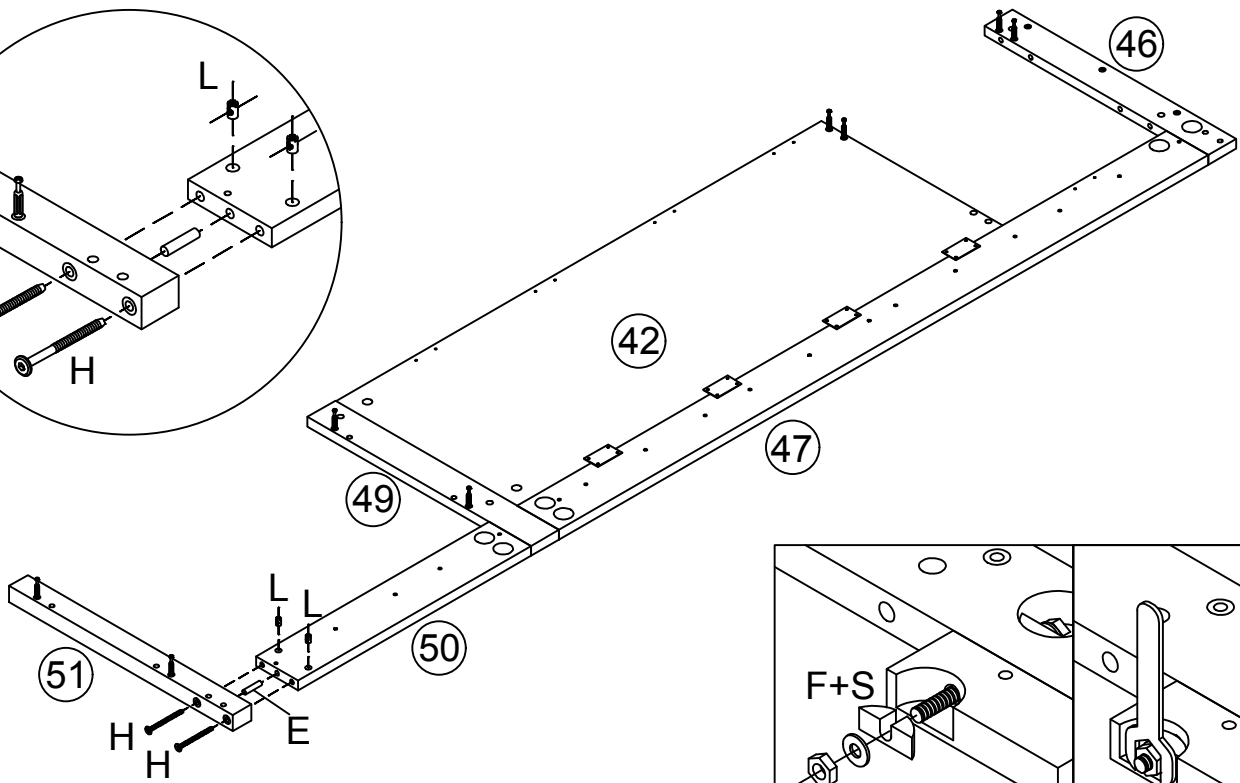
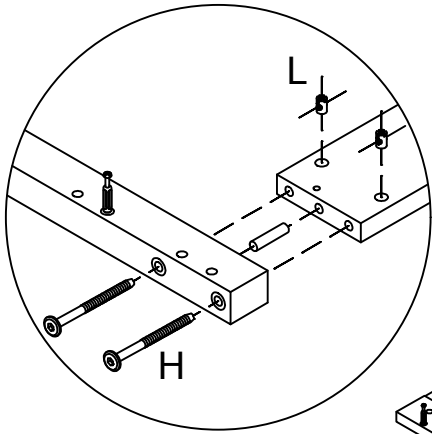
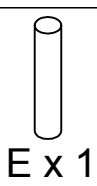

42

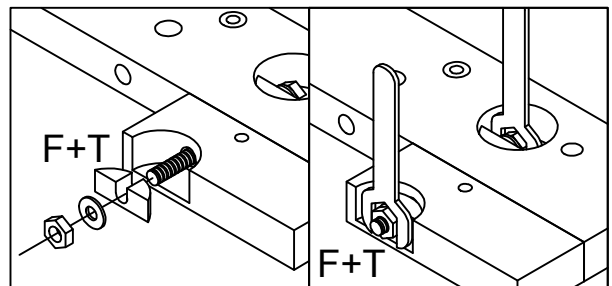
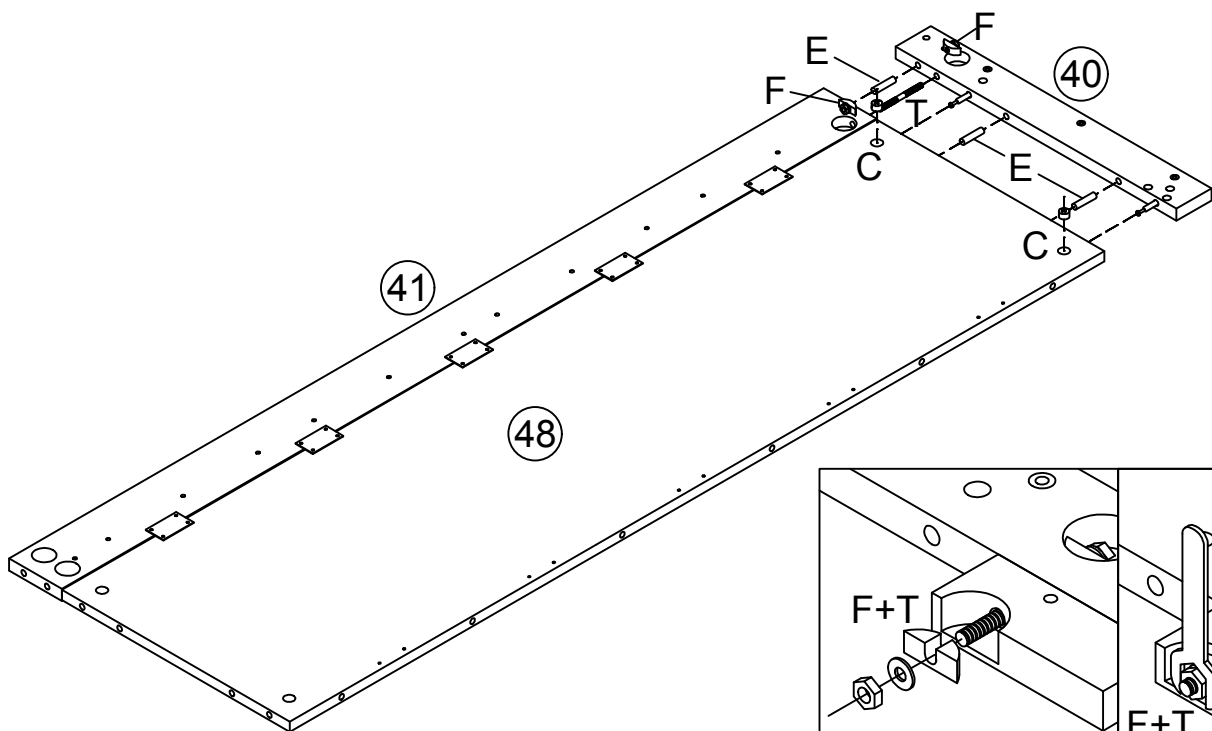
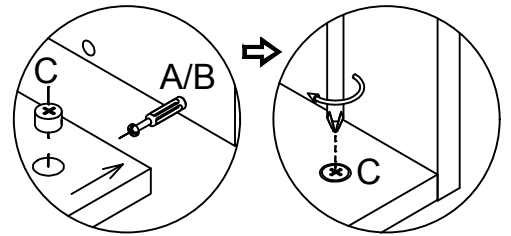
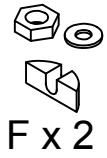
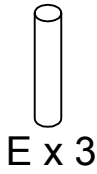

43



E x 2

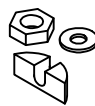

F x 4



S x 2



C x 2

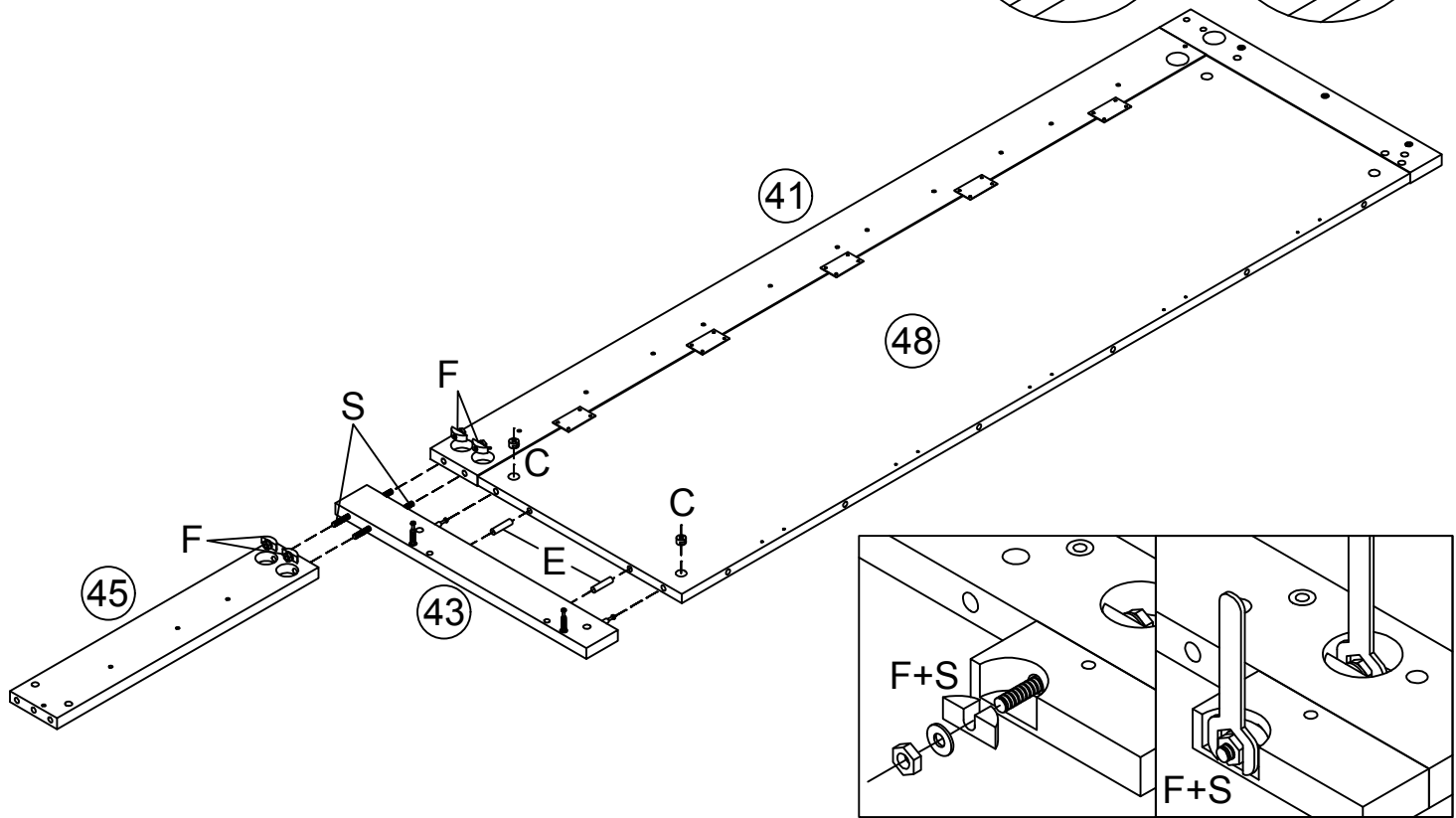
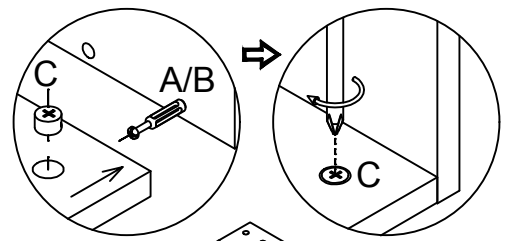

44

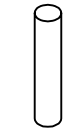

E x 1



H x 2



L x 2

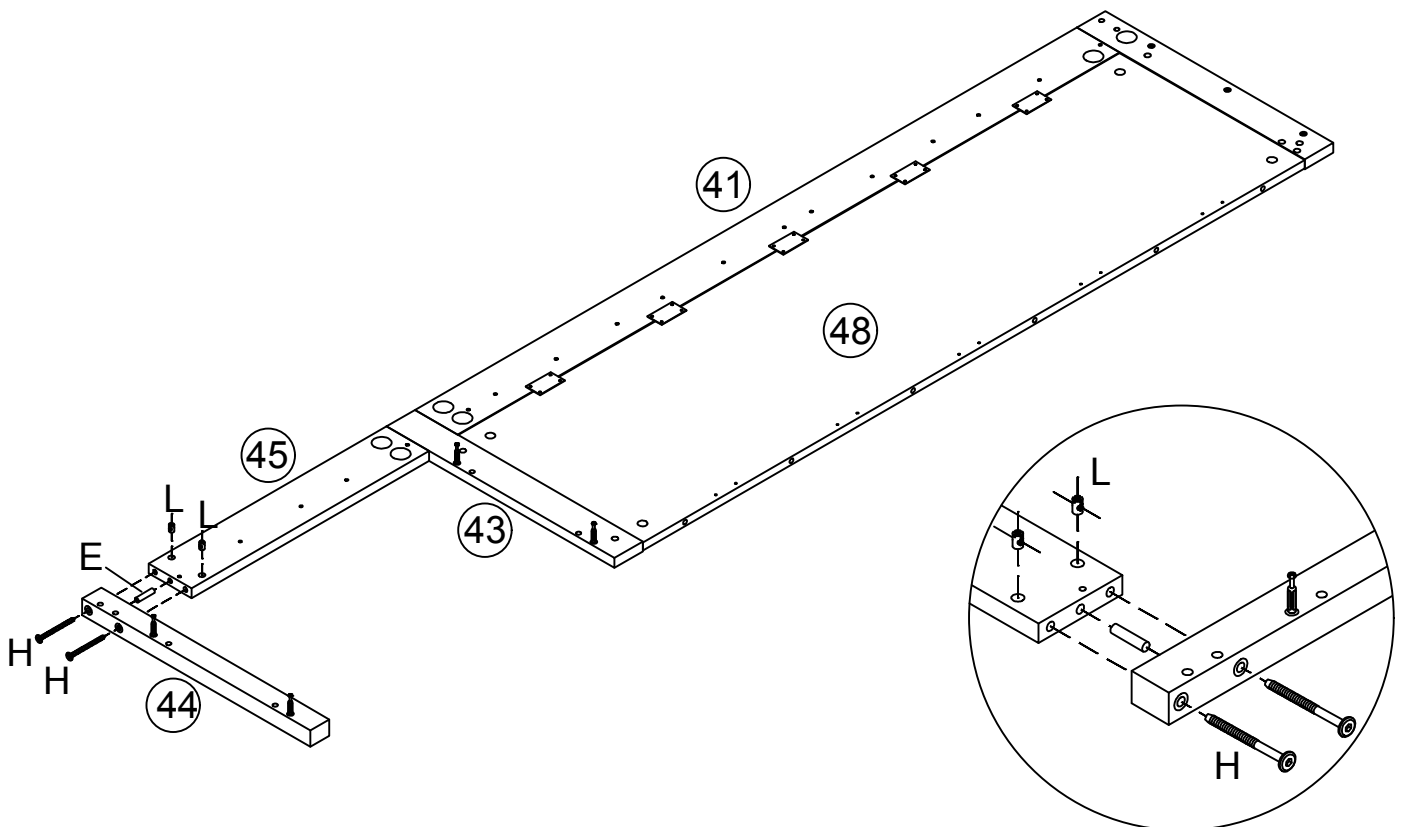

45



E x 4



C x 8

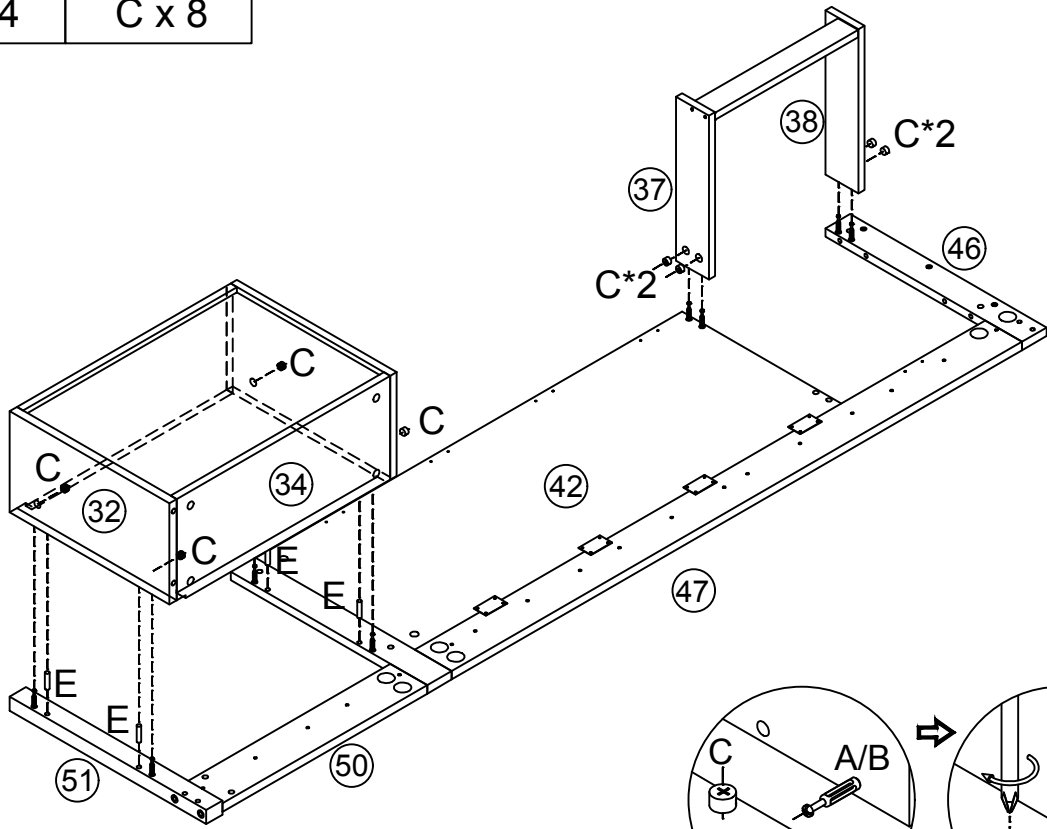

46



E x 4



C x 4

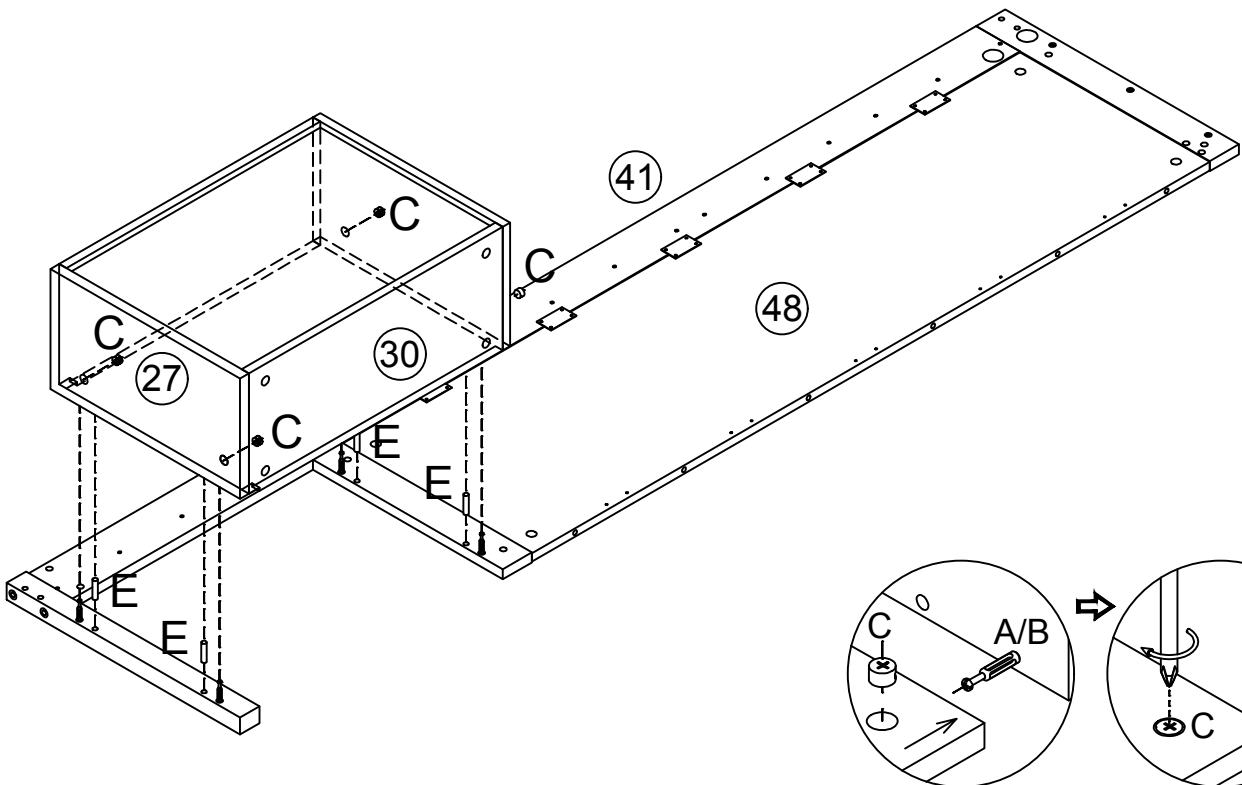

47

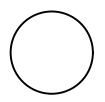

X x 12

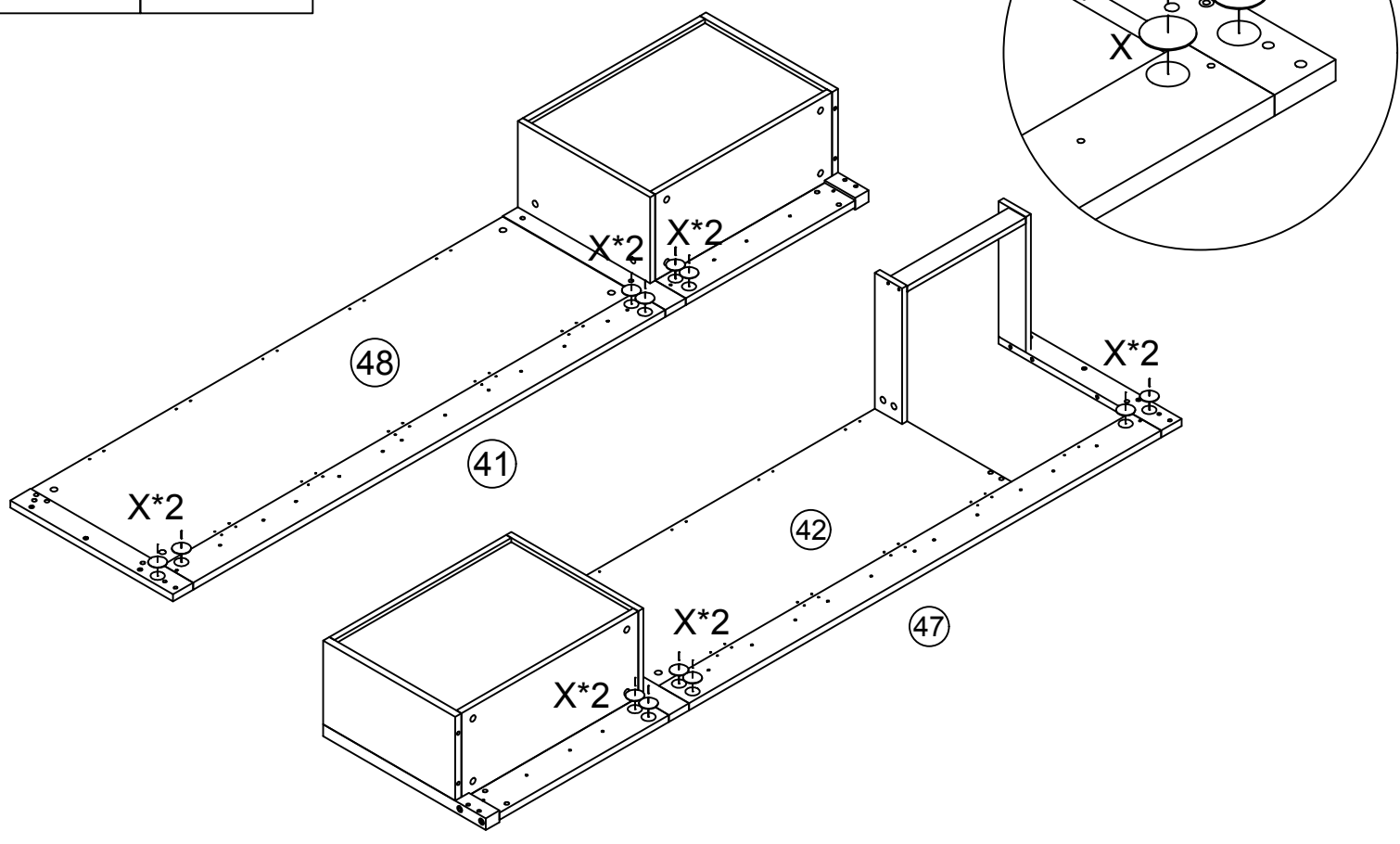

48



W x 36

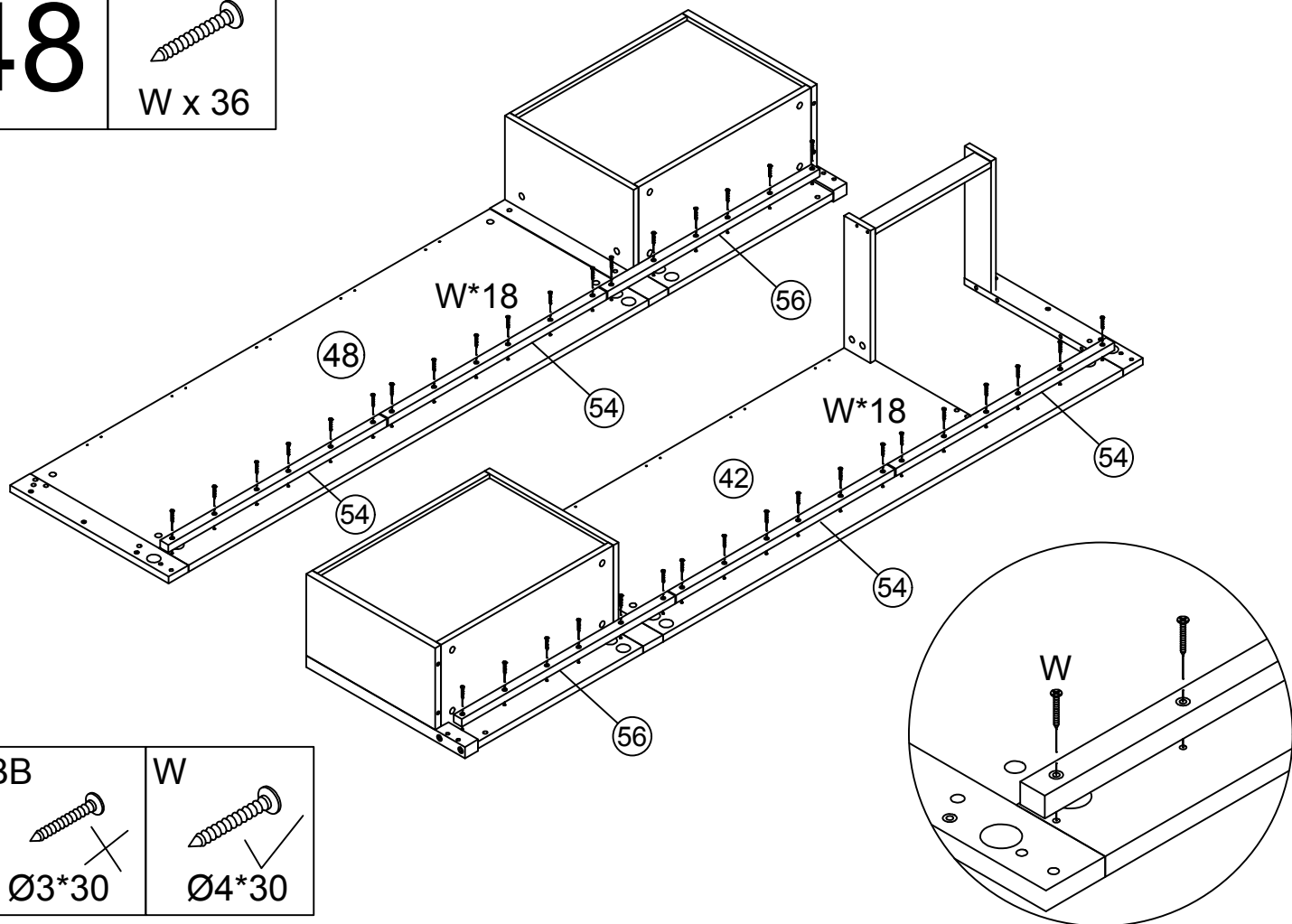

BB



Ø3*30

W



Ø4*30

49



H x 4



L x 4

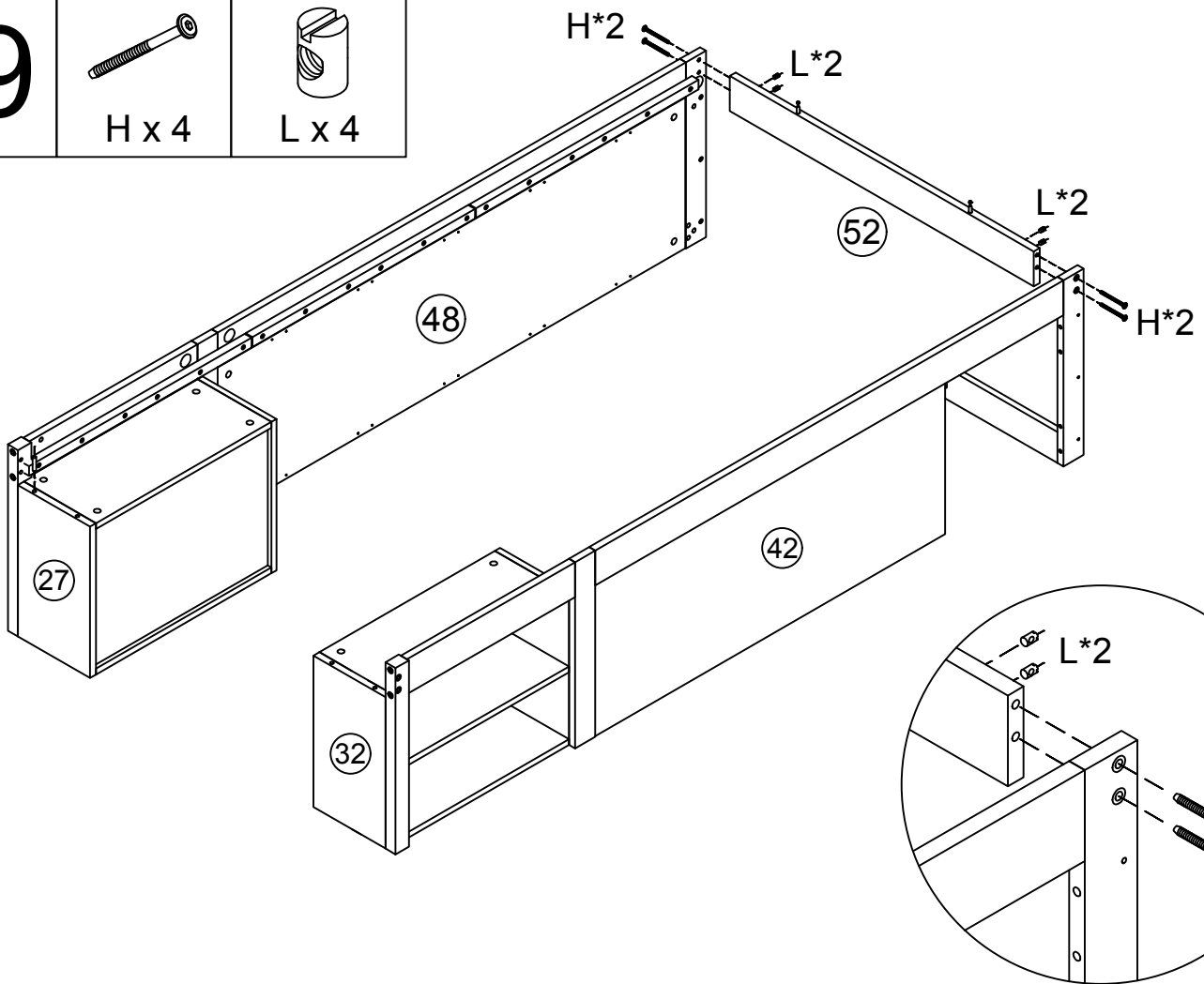

50

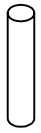

E x 4

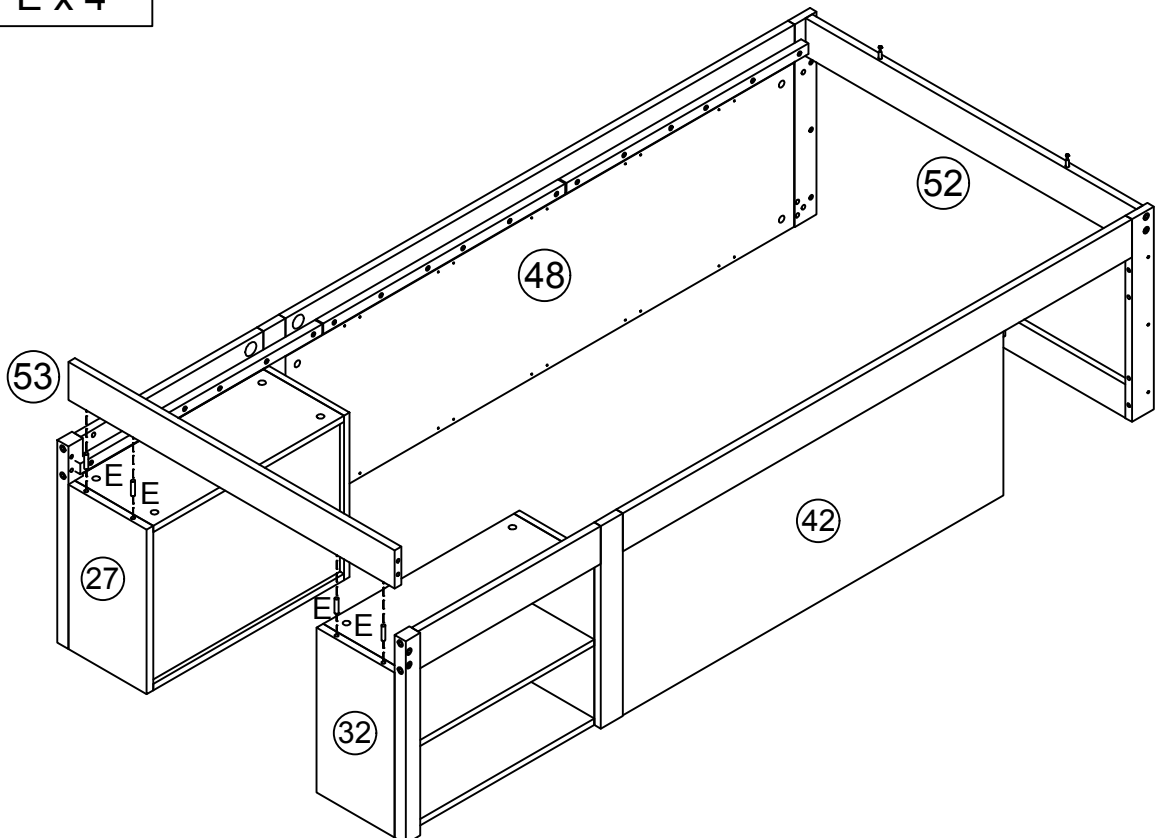

51



H x 4



L x 4

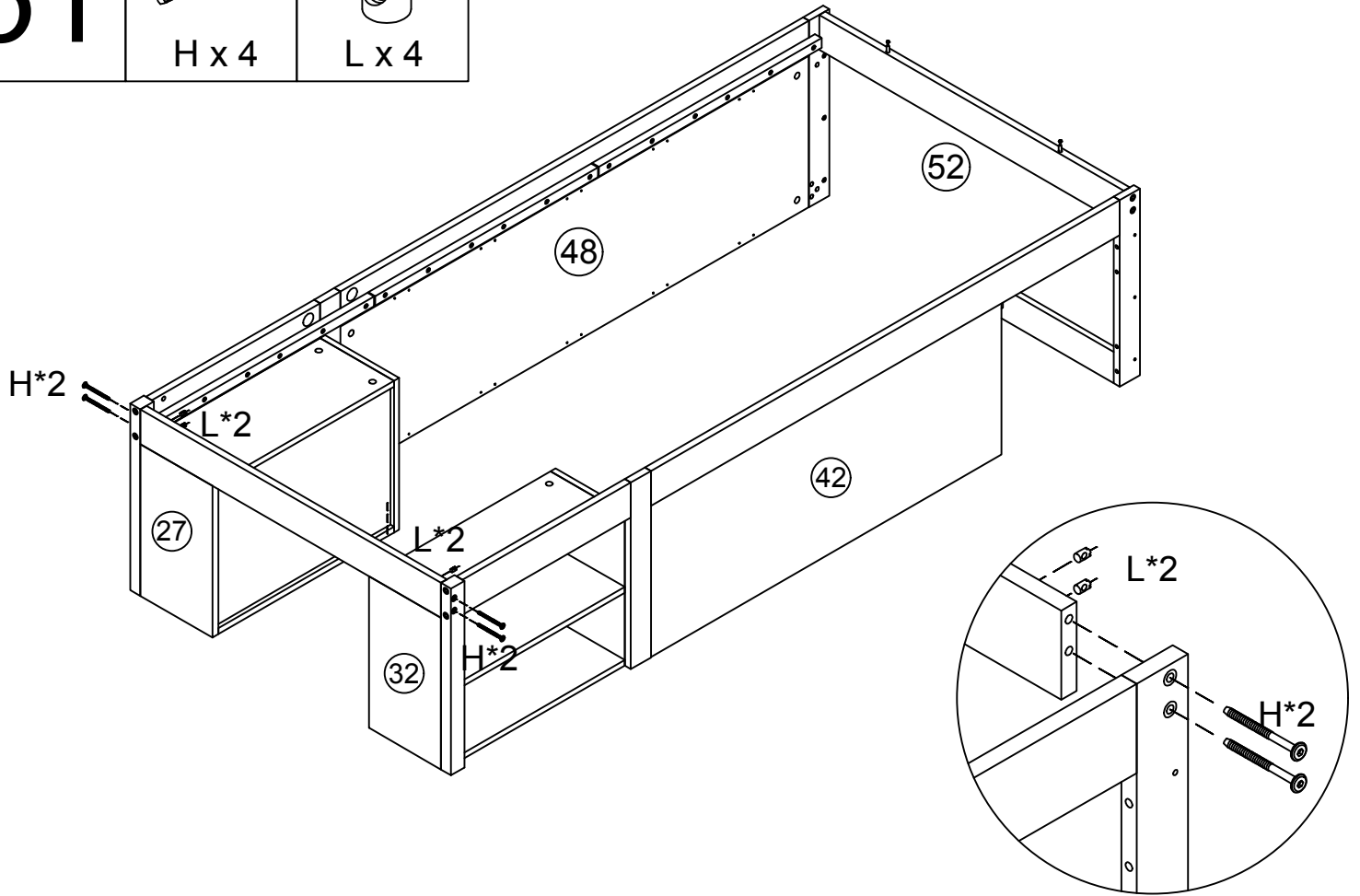

52



C x 2

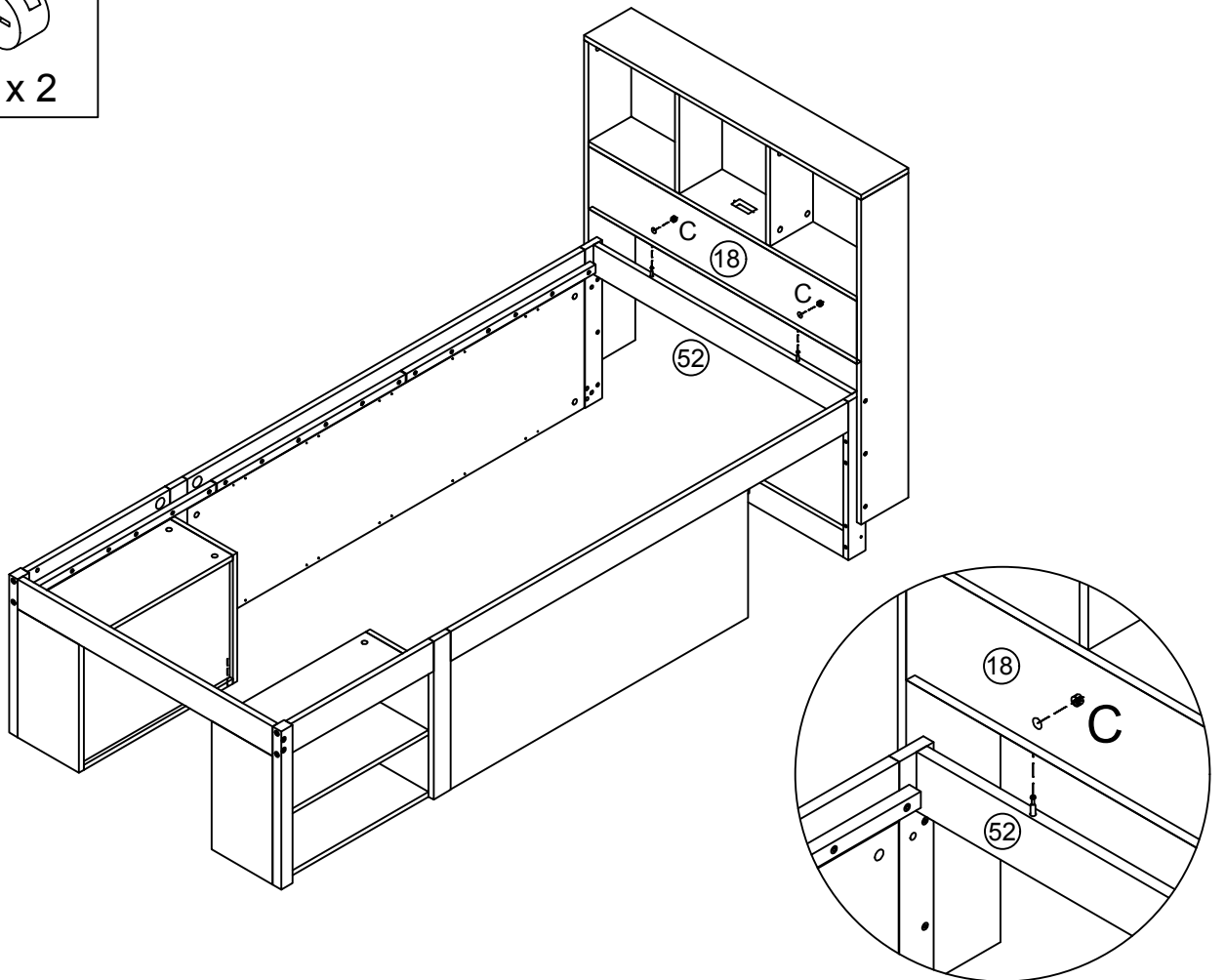

53

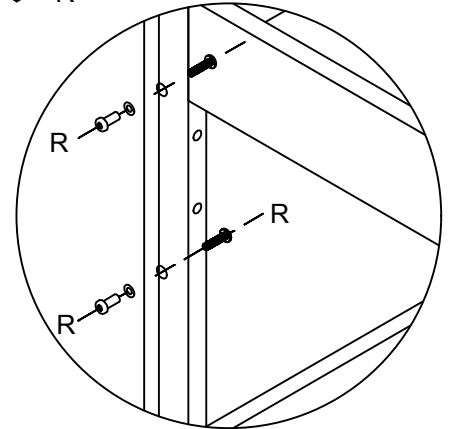
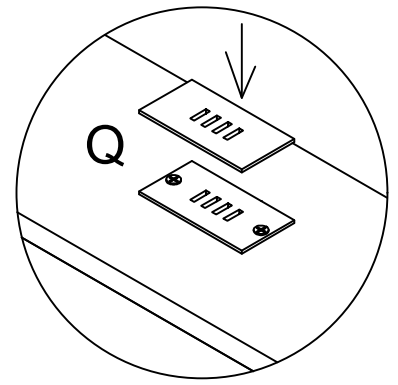
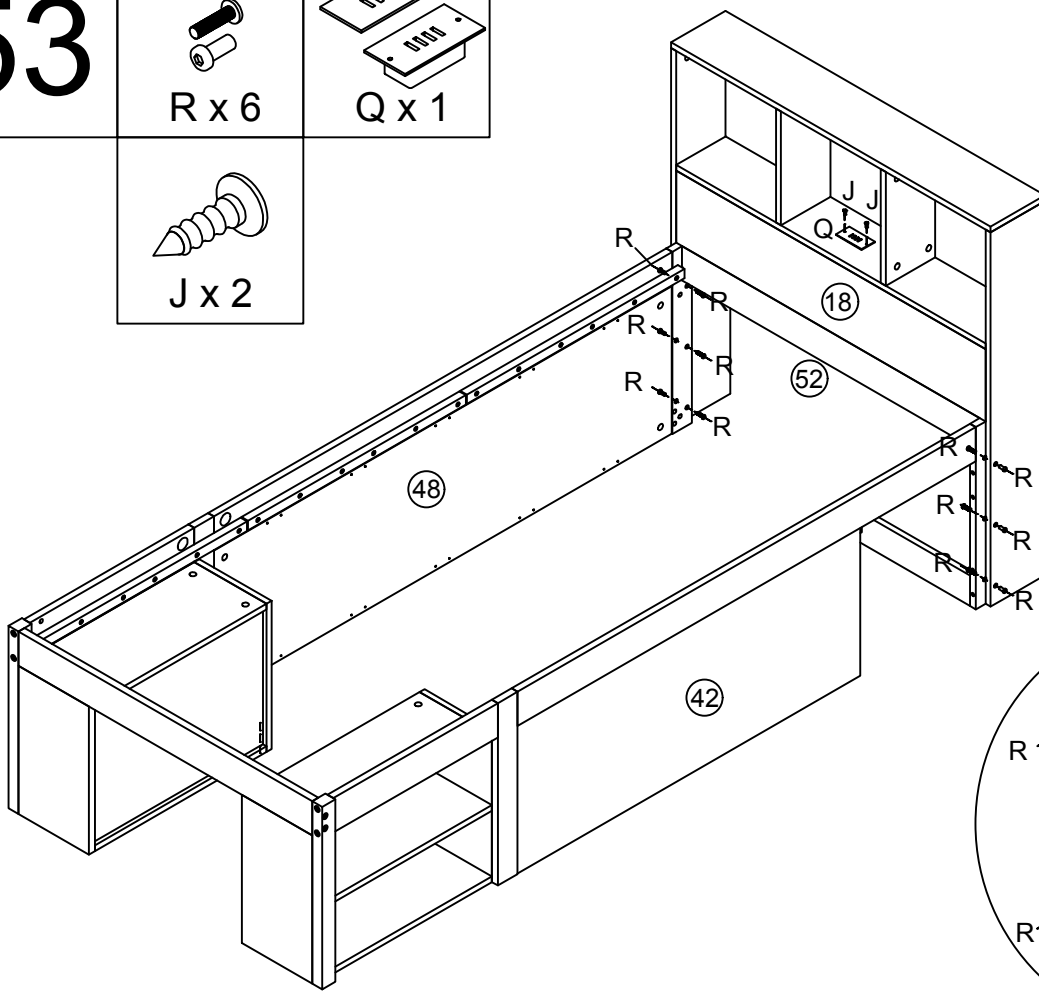
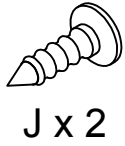
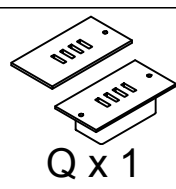

54

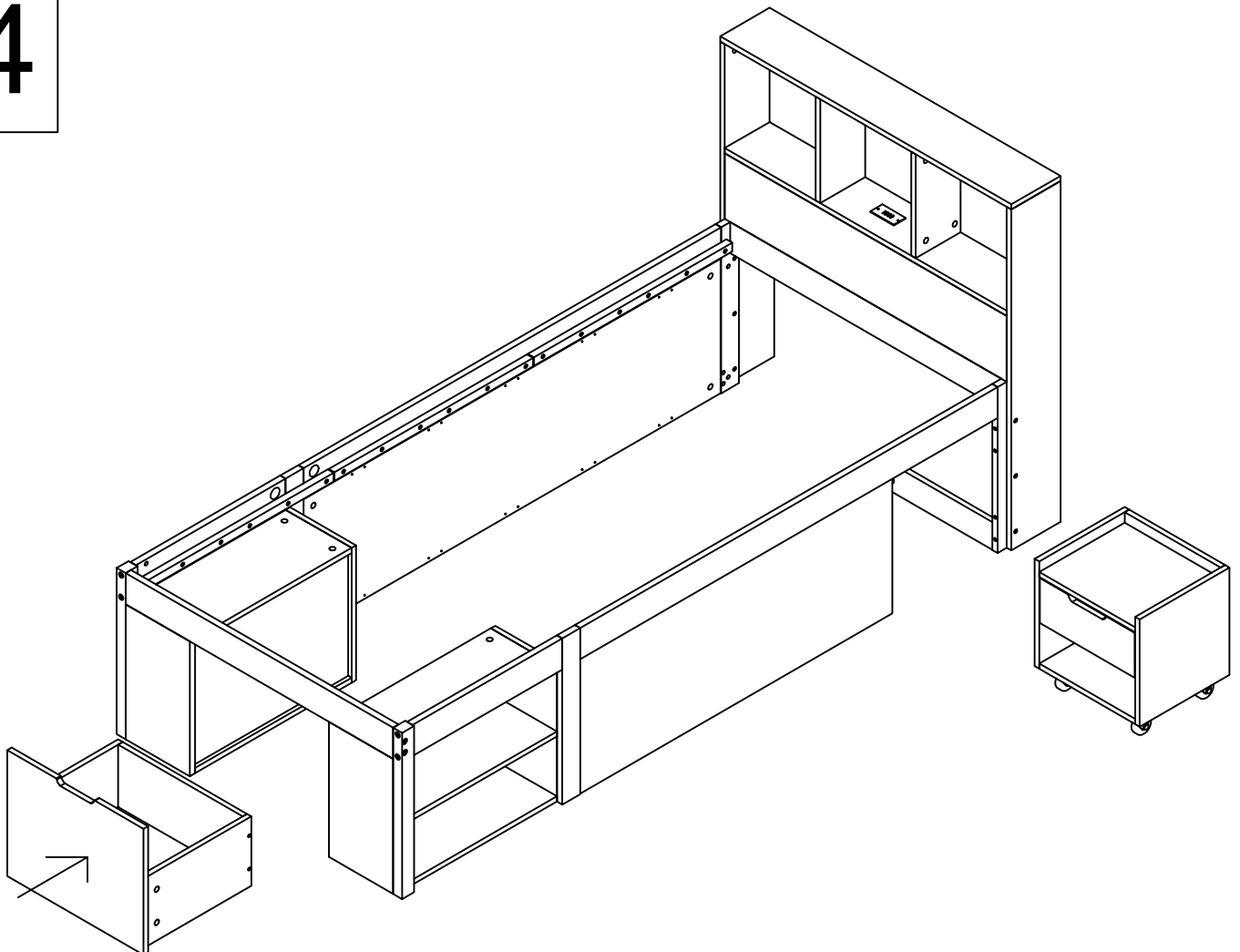

55

BB x 32

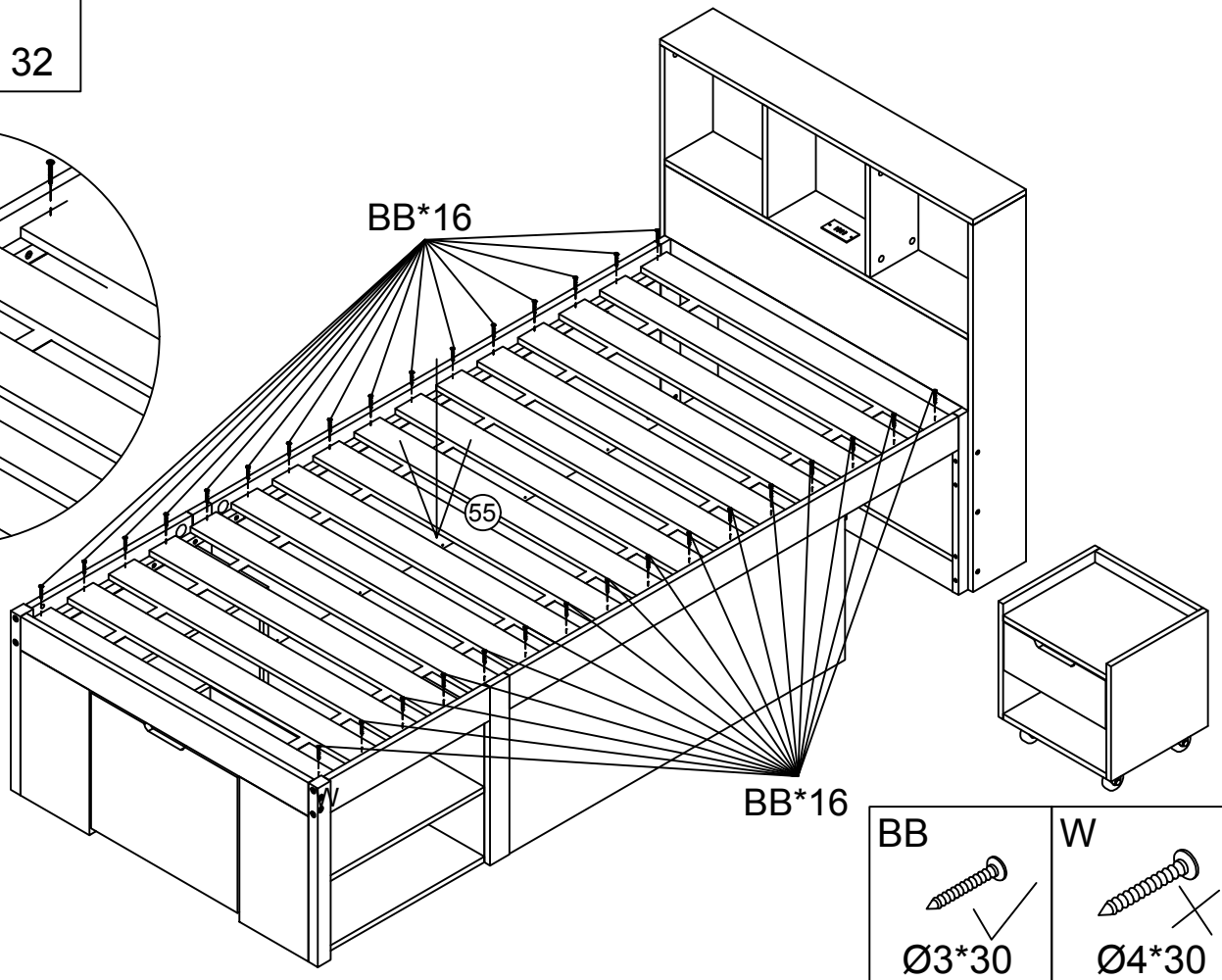
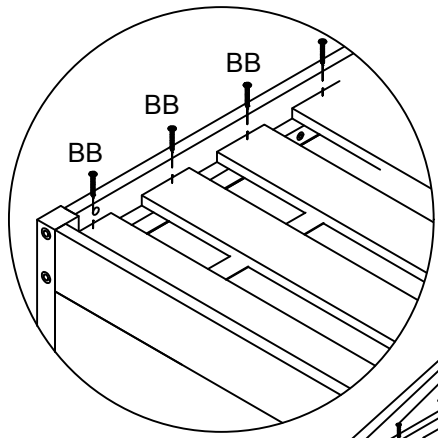

BB	W
Ø3*30	Ø4*30

56

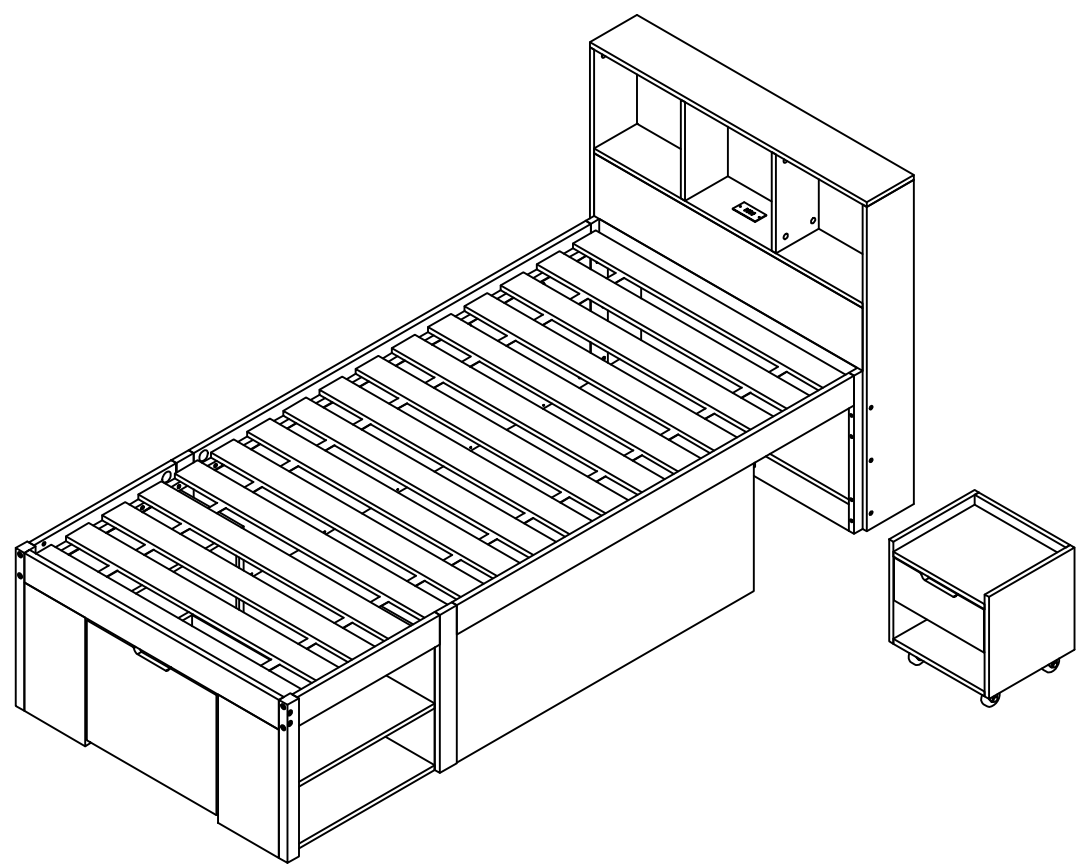

57



Y x 102

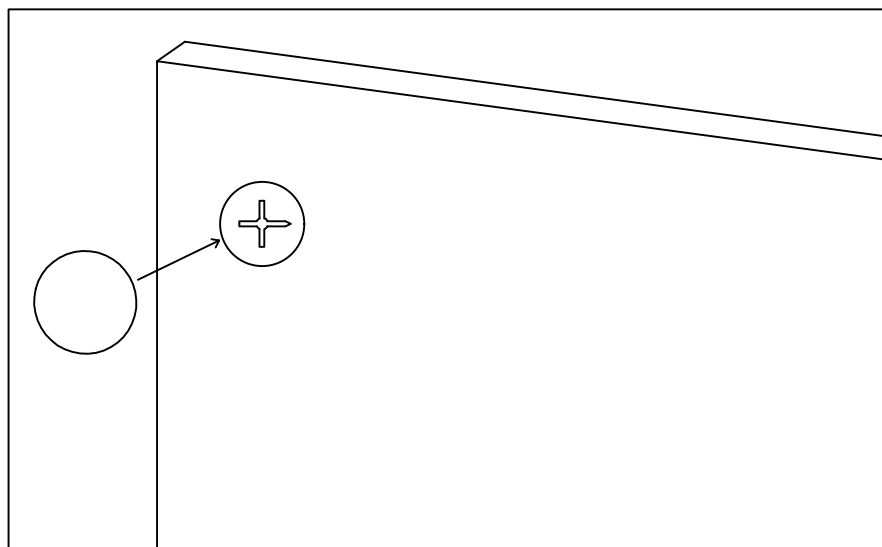

UK: After installing the product, stick the number Y on the perforated position

FR: Une fois le produit installé, collez le numéro Y à l'endroit où il y a des trous

DE: Nach der Installation des Produkts kleben Sie die Nummer Y auf die perforierte Position

IT: Dopo l'installazione del prodotto, fissare il numero Y sulla posizione perforata

ES: Después de instalar el producto, pegue el número Y en la posición perforada

①



②



③



④



⑤



⑥



⑦



⑧





Certificate of Compliance

Certificate Number: ZHT-241016118C

Certificate's Holder : Shenzhen Lanling Optoelectronics Technology Co., Ltd
Zertifikatsinhaber : 511-G5, Building C, No. 101 Fukang Road, Henggang Community, Henggang Street, Longgang District, Shenzhen City, Guangdong Province

Manufacturer : Shenzhen Lanling Optoelectronics Technology Co., Ltd
Hersteller : 511-G5, Building C, No. 101 Fukang Road, Henggang Community, Henggang Street, Longgang District, Shenzhen City, Guangdong Province

Trade Mark : /
Warenzeichen : /

Product : LED Strip
Produkt : LED Strip

Model(s) : LED2835X34
Bezeichnung : LED5050X18, LED5050X30, LED5050X48, LED5050X60, LED5050X72, LED5050X90, LED5050X120, LED2835X30, LED2835X60, LED2835X120, LED2835X180, LED2835X240, LED2835X42, LED2835X84, LED3528X120, LED3528X240, LED5730X60, LED5730X72, LED5730X84, LED3535X60, LED3535X120

Test Standard : IEC 62321-3-1:2013, IEC 62321-5:2013, IEC 62321-4:2013+A1:2017,
Geprüft nach : IEC 62321-7-1:2015, IEC 62321-7-2: 2017, IEC 62321-6:2015, IEC 62321-8:2017

Test Report No. : ZHT-241016118R
Bericht Nr : ZHT-241016118R

The EUT described above has been consolidated by us and found in compliance with the council RoHS Directive 2011/65/EU Annex II amending Annex (EU)2015/863 and amending Annex (EU)2017/2102. It is possible to use CE marking to demonstrate the compliance with this RoHS Directive. It is only valid in connection with the test report.

RoHS



The information of the certificate can be checked through www.zht-lab.cn.

The ROHS mark which is shown on the certificate can only be used under the conditions that the products complete with all of the relevant Directives of ROHS Declaration of Conformity. The Manufacturer should be responsible for the internal production control so that the products complied with the essential requirements of the above mentioned Directive(s). Certificate holder must notify all changes to the original certification laboratory of Guangdong Zhonghan Testing Technology Co., Ltd.



Guangdong Zhonghan Testing Technology Co., Ltd.

Address: Room 104, Building 1, Yibaolai Industrial Park, Qiaotou Community, Fuhai Street, Bao'an District, Shenzhen, Guangdong, China

Tel.: +86-755-27782934 [Http://www.zht-lab.cn](http://www.zht-lab.cn) E-mail: admin@zht-lab.cn

Shenzhen ZKT Technology Co., Ltd.
 1/F, No. 101, Building B, No. 6, Tangwei Community Industrial Avenue,
 Fuhai Street, Bao'an District, Shenzhen, China



Certificate of Compliance

Certificate Number: ZKT-250902L21450C

Certificate's Holder : Shenzhen Lanling Optoelectronics Technology Co., Ltd
 511-G5, Building C, No. 101 Fukang Road, Henggang Community,
 Henggang Street, Longgang District, Shenzhen City, Guangdong
 Province

Manufacturer : Shenzhen Lanling Optoelectronics Technology Co., Ltd
 511-G5, Building C, No. 101 Fukang Road, Henggang Community,
 Henggang Street, Longgang District, Shenzhen City, Guangdong
 Province

Trade Mark : /

Product : LED Strip

Model(s) : CWG-5050RGB-60D-5v
 LED5050X18, LED5050X30, LED5050X48, LED5050X60, LED5050X72,
 LED5050X90, LED5050X120, LED2835X30, LED2835X60,
 LED2835X120, LED2835X180, LED2835X240, LED3528X30,
 LED3528X60, LED3528X120, LED3528X240, LED5730X60,
 LED5730X72, LED5730X84, LED3535X60, LED3535X120

Test Standard : EN IEC 62031:2020+A11:2021

This Attestation of Compliance is issued on a voluntary basis for electrical equipment below the voltage limits of Low Voltage Directive 2014/35/EU. The essential requirements are fulfilled accordingly based on the technical specifications applicable at the time of issuance. See also notes overleaf. It is only valid in connection with the test report number: ZKT-250902L21450S.



This Certificate of Conformity is based on single evaluation of the submitted sample(s) of the above mentioned product. It does not imply an assessment of the whole product and relevant Directives to be observed.

Shenzhen ZKT Technology Co., Ltd.
 1/F, No. 101, Building B, No. 6, Tangwei Community Industrial Avenue,
 Fuhai Street, Bao'an District, Shenzhen, China



Certificate of Compliance

Certificate Number: ZKT-250902L21449C

Certificate's Holder : Shenzhen Lanling Optoelectronics Technology Co., Ltd
 511-G5, Building C, No. 101 Fukang Road, Henggang Community,
 Henggang Street, Longgang District, Shenzhen City, Guangdong
 Province

Manufacturer : Shenzhen Lanling Optoelectronics Technology Co., Ltd
 511-G5, Building C, No. 101 Fukang Road, Henggang Community,
 Henggang Street, Longgang District, Shenzhen City, Guangdong
 Province

Trade Mark : /

Product : LED Strip

Model(s) : CWG-5050RGB-60D-5V
 LED5050X18, LED5050X30, LED5050X48, LED5050X72, LED5050X90,
 LED5050X120, LED2835X30, LED2835X60, LED2835X120,
 LED2835X180, LED2835X240, LED3528X30, LED3528X60,
 LED3528X120, LED3528X240, LED5730X60, LED5730X72, LED5730X84,
 LED3535X60, LED3535X120

Test Standard : EN IEC 55015:2019+A11:2020
 EN IEC 61000-3-2:2019 + A1:2021 + A2:2024
 EN 61000-3-3:2013 + A1:2019 + A2:2021
 EN IEC 61547:2023

This Attestation of Compliance is issued on a voluntary basis for electrical equipment below the voltage limits of EMC Directive 2014/30/EU. The essential requirements are fulfilled accordingly based on the technical specifications applicable at the time of issuance. See also notes overleaf. It is only valid in connection with the test report number: ZKT-250902L21449E.



This Certificate of Conformity is based on single evaluation of the submitted sample(s) of the above mentioned product. It does not imply an assessment of the whole product and relevant Directives to be observed.

Shenzhen ZKT Technology Co., Ltd.
 1/F, No. 101, Building B, No. 6, Tangwei Community Industrial Avenue,
 Fuhai Street, Bao'an District, Shenzhen, China



Certificate of Compliance

Certificate Number: ZKT-25C

Certificate's Holder : Shenzhen Lanling Optoelectronics Technology Co., Ltd
 511-G5, Building C, No. 101 Fukang Road, Henggang
 Community, Henggang Street, Longgang District,
 Shenzhen City, Guangdong Province
Manufacturer : Shenzhen Lanling Optoelectronics Technology Co., Ltd
 511-G5, Building C, No. 101 Fukang Road, Henggang
 Community, Henggang Street, Longgang District,
 Shenzhen City, Guangdong Province
Trade Mark : /
Product : Controller strip lights
Model(s) : YH-358

REQUIREMENT	STANDARD	Report No.
Art.3.1(a) Safety	EN 60598-2-21:2015 EN IEC 60598-1:2024+A11:2024 EN IEC 62031:2020+A11:2021	ZKT-25S
Art.3.1(a) Health	EN 62479:2010 EN 50663:2017	ZKT-25E-3
Art.3.1(b) EMC	ETSI EN 301 489-1 V2.2.3 (2019-11) ETSI EN 301 489-17 V3.3.1 (2024-09) EN IEC 61000-3-2:2019 + A1:2021 + A2:2024 EN 61000-3-3:2013 + A1:2019 + A2:2021	ZKT-25E-1
Art.3.2 Radio	ETSI EN 300 328 V2.2.2 (2019-07)	ZKT-25E-2

This Attestation of Compliance is issued on for electrical equipment below the voltage limits of
 Radio Equipment Directive (RED) 2014/53/EU. The essential requirement are fulfilled accordingly
 based on the technical specifications applicable at the time of issuance.



Manager
 Nov. 17, 2025

This Certificate of Conformity is based on single evaluation of the submitted sample(s) of the above mentioned
 product. It does not imply an assessment of the whole product and relevant Directives to be observed.



KeySense Testing & Certification International Co., Ltd.
 1-3F, Lab Building, No.29 District, Zhongkai Hi-Tech
 Industrial Development Park, Huizhou, Guangdong,
 China

Tel:0752-3219929
 Fax:0752-3219929
<http://www.kst-cert.com>

Technical Compliance Statement

Certificate No.: KST240304E008Q01

Report No.: KST240304E008Q01

The following product has been tested by us with the listed standards and found in Compliance with the council EMC directive 2014/30/EU. It is demonstrative for the Compliance with this EMC Directive.

Holder: DONGGUAN BAIYOU ELECTRONIC CO LTD
Address: 2F A Building, Wufeng Industrial, Jintan Road, Danwu Shijie Town, Dongguan, Guangdong
Product: USB CHARGER
Model Name: BY213-TD04-C
Trade Name: N/A

Test Standard	
EN 55032:2015+A1:2020	Electromagnetic compatibility of multimedia equipment – Emission requirements
EN IEC 61000-3-2:2019+A1:2021	Electromagnetic Compatibility (EMC) Part 3-2:Limits-Limits for harmonic current emissions(equipment input current ≤ 16A per phase)
EN 61000-3-3:2013+A2:2021	Electromagnetic Compatibility(EMC) Part 3-3:Limits-limitation of voltage changes, voltage fluctuations and flicker in public low-voltage supply systems, for equipment with rated current ≤ 16A per phase and not subject to conditional connection
EN 55035:2017+A11:2020	Electromagnetic compatibility of multimedia equipment – Immunity requirements

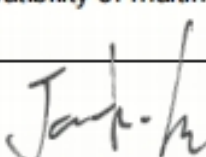

Signature: 
 Name: Jack.Li
 Position: Supervisor
 Date: April 26, 2024

The statement is based on single evaluation of one sample of above mentioned product. It does not imply an assessment of the whole production and does not permit the use of the test lab. Logo.



Certificate of Conformity

No.:CCI240300872EN-1CER

Reference Report No. : CCI240300872EN-1

Applicant : DONGGUAN BAIYOU ELECTRONIC CO LTD
Address : 2F A Building, Wufeng Industrial, Jintan Road,
Danwu Shijie Town, Dongguan, Guangdong

Sample Name : USB CHARGER
Model/Item No. : BY213-TD04-C

Test Standards : IEC 62321-2:2013 IEC 62321-6:2015
IEC 62321-3-1:2013 IEC 62321-7-1:2015
IEC 62321-4: 2013+A1:2017 IEC 62321-7-2:2017
IEC 62321-5: 2013 IEC 62321-8:2017

The submitted sample(s) stated as above has(have) been tested by us with the listed standards and found in conformity with the requirements stated in Directive 2011/65/EU of the European Parliament and of the Council with regard to the restriction of the use of certain hazardous substances in electrical and electronic equipment and its subsequent amendments as well as Commission Delegated Directive (EU) 2015/863. It is possible to use CE marking on the product to demonstrate the conformity with this Directive.

This certification is part of the full test report(s) and should be read in conjunction with it. The certificate is based on a single evaluation of one sample of above-mentioned products. It does not imply an assessment of the whole production. Other CE marking directives may be applied, they have not been considered during this RoHS conformity assessment.





KeySense Testing & Certification International Co., Ltd.
 1-3F, Lab Building, No.29 District, Zhongkai Hi-Tech
 Industrial Development Park, Huizhou, Guangdong,
 China

Tel:0752-3219929
 Fax:0752-3219929
<http://www.kst-cert.com>

Technical Compliance Statement

Certificate No.: KST240304L008Q01

Report No.: KST240304L008Q01

The following product has been tested by us with the listed standards and found in Compliance with the council LVD directive 2014/35/EU. It is demonstrative for the Compliance with this LVD Directive.

Holder: DONGGUAN BAIYOU ELECTRONIC CO LTD
Address: 2F A Building, Wufeng Industrial, Jintan Road, Danwu Shijie Town, Dongguan, Guangdong
Product: USB CHARGER
Model Name: BY213-TD04-C
Trade Name: N/A

Test Standard	
EN 62368-1:2014+A11:2017	Audio/video, information and communication technology equipment Part 1: safety requirements



Signature: 

Name:

Tony Xu

Position:

General Manager

Date:

Apr. 26, 2024



The statement is based on single evaluation of one sample of above mentioned product. It does not imply an assessment of the whole production and does not permit the use of the test lab. Logo.