

Installation sanleitung

Installation Instruction

Instruction d'installation

SKU:N636P195135 / N636P195136

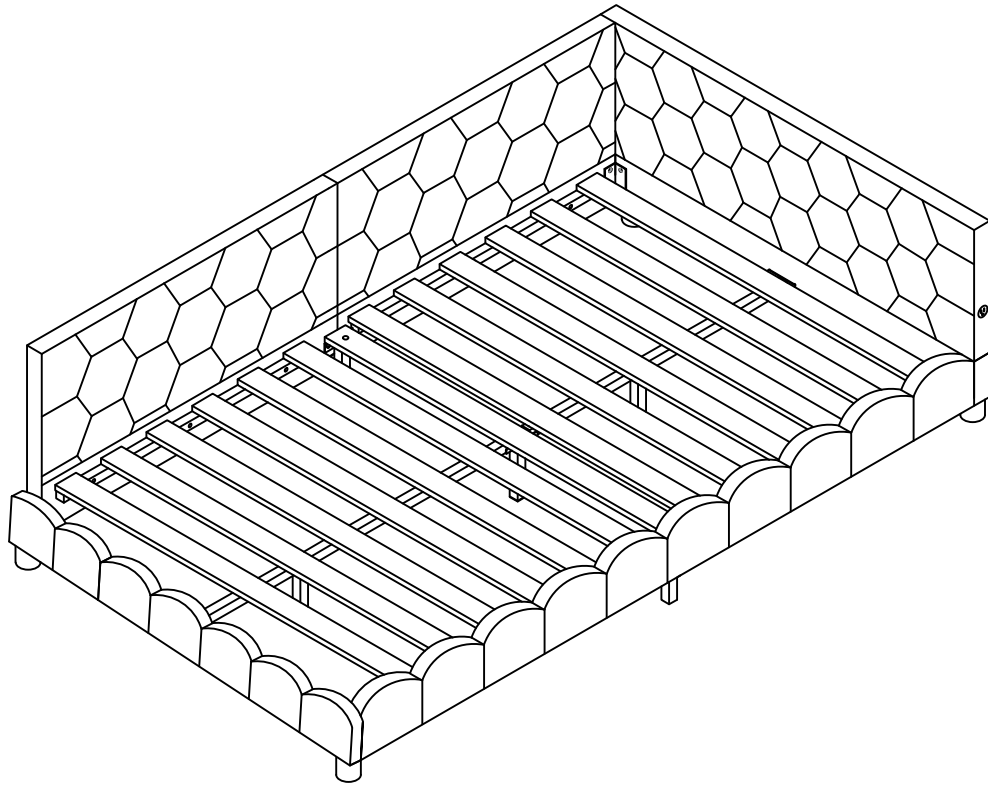

Unser Produkt wird Ihnen in 2 Paketen geliefert. Die Lieferzeiten dieser 2 Pakete können abweichen, bitte haben Sie etwas Geduld und vielen Dank für Ihr Verständnis.

Our product will be delivered to you in 2 packages. The delivery times of these 2 packages may differ, please be patient and thank you for your understanding.

Notre produit vous sera livré en 2 colis. Les délais de livraison de ces 2 colis peuvent différer, soyez patient et merci pour votre compréhension.



English

IMPORTANT FOR GAS LIFT BEDS&MAINTAINCE

- Please place the mattress on top of the bed frame.
- Please do not pull on the strap handles.
- Please press heavily to release the compressed gas.
- Periodically check all screw & fixings to ensure they are secure.
- When moving your product, carefully lift into place.
- Wipe clean with a slightly damp cloth- please do not use abrasive chemicals or bleach.
- Do NOT allow children to operate the lift mechanism.
- Do NOT allow children near the lift base when operating the mechanism.
- Do NOT stand inside the bed or the internal storage base.
- Do NOT overload the internal storage base.
- DO NOT jump on the product or any of its parts.

Deutsch

WICHTIG FÜR GASLIFT-BETTEN&WARTUNG

- Bitte legen Sie die Matratze oben auf den Bettrahmen.
- Bitte ziehen Sie nicht an den Gurtgriffen.
- Bitte drücken Sie kräftig, um das komprimierte Gas freizusetzen.
- Überprüfen Sie regelmäßig alle Schrauben und Befestigungen, um sicherzustellen, dass sie sicher sind.
- Wenn Sie Ihr Produkt bewegen, heben Sie es vorsichtig an seinen Platz.
- Mit einem leicht feuchten Tuch abwischen - bitte keine scheuernden Chemikalien oder Bleichmittel verwenden.
- Erlauben Sie Kindern NICHT, den Hebemechanismus zu bedienen.
- Lassen Sie Kinder NICHT in die Nähe des Liftsockels, wenn Sie den Mechanismus bedienen.
- Stellen Sie sich NICHT in das Bett oder in die Innenablage.
- Überlasten Sie den internen Liftsockel NICHT.
- Springen Sie NICHT auf das Produkt oder eines seiner Teile.

Français

IMPORTANT POUR LES LITS À RELEVAGE DE GAZ&MAINTENANCE

- Veuillez placer le matelas sur le dessus du cadre de lit.
- Ne tirez pas sur les poignées de la sangle.
- Appuyez fortement pour libérer le gaz comprimé.
- Vérifiez régulièrement que toutes les vis et fixations sont bien en place.
- Lorsque vous déplacez votre produit, soulevez-le avec précaution pour le mettre en place.
- Nettoyez avec un chiffon légèrement humide - n'utilisez pas de produits chimiques abrasifs ou d'eau de Javel.
- Ne laissez pas les enfants utiliser le mécanisme de levage.
- Ne laissez pas les enfants s'approcher de la base de levage lorsqu'ils actionnent le mécanisme.
- Ne vous tenez PAS à l'intérieur du lit ou de la base de stockage interne.
- Ne surchargez pas la base de stockage interne.
- Ne pas sauter sur le produit ou l'une de ses parties.

Italiano

IMPORTANTE! CONSERVARE PER RIFERIMENTO FUTURO: LEGGERE ATTENTAMENTE

- Deve essere assemblato da un adulto. L'assemblaggio deve essere controllato da un adulto prima dell'uso
- **ATTENZIONE!** Tenere tutte le viti, le piccole parti e i sacchetti di plastica fuori dalla portata dei bambini
- Identificare correttamente tutte le parti prima dell'assemblaggio
- Non utilizzare mai l'articolo se alcune parti sono rotte o mancanti
- In caso di problemi, si prega di contattare il nostro Servizio Post Vendita
- Le istruzioni del produttore devono essere sempre seguite
- Cura: Pulire con un panno morbido e asciutto. In caso di macchie più estese, strofinare accuratamente con una spugna leggermente umida e nonspugna leggermente umida e non abrasiva
- Evitare il rischio di incendio, non collocando i mobili vicino a fonti di accensione o a oggetti caldi
- Non saltare sul letto

Español

¡ IMPORTANTE ! CONSERVELO PARA FUTURAS CONSULTAS: LEA ATENTAMENTE

- Debe ser montado por un adulto. El montaje debe ser comprobado por un adulto antes del uso
- ADVERTENCIA Mantenga todos los tornillos, piezas pequeñas y bolsas de plástico fuera del alcance de los niños.
- Identifique correctamente todas las piezas antes de montarlas
 - Nunca utilice su artículo si alguna de sus piezas está rota o falta
 - Si surge algún problema, póngase en contacto con nuestro Servicio Postventa
 - Las instrucciones del fabricante deben seguirse en todo momento
 - Cuidado: Limpiar con un paño suave y seco. En caso de manchas más grandes, frote cuidadosamente con una esponja no abrasiva ligeramente humedecida.
 - Evite el riesgo de incendio no colocando los muebles cerca de fuentes de ignición u objetos calientes.
 - No saltar sobre la cama.





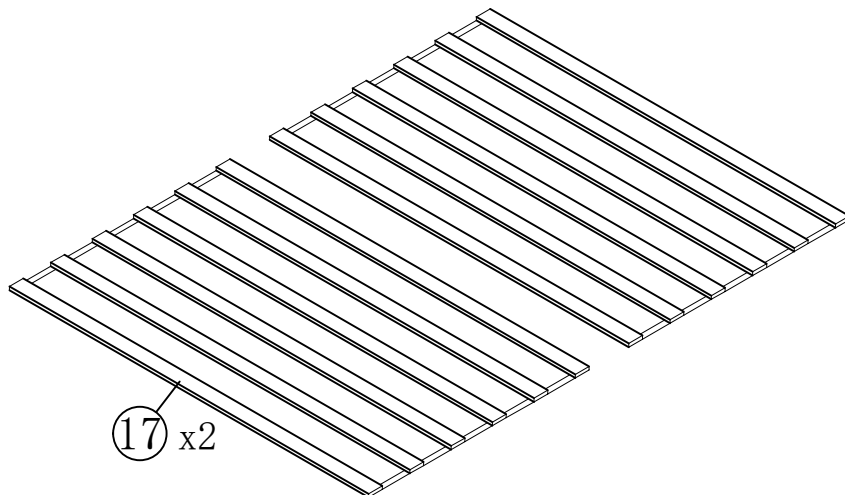
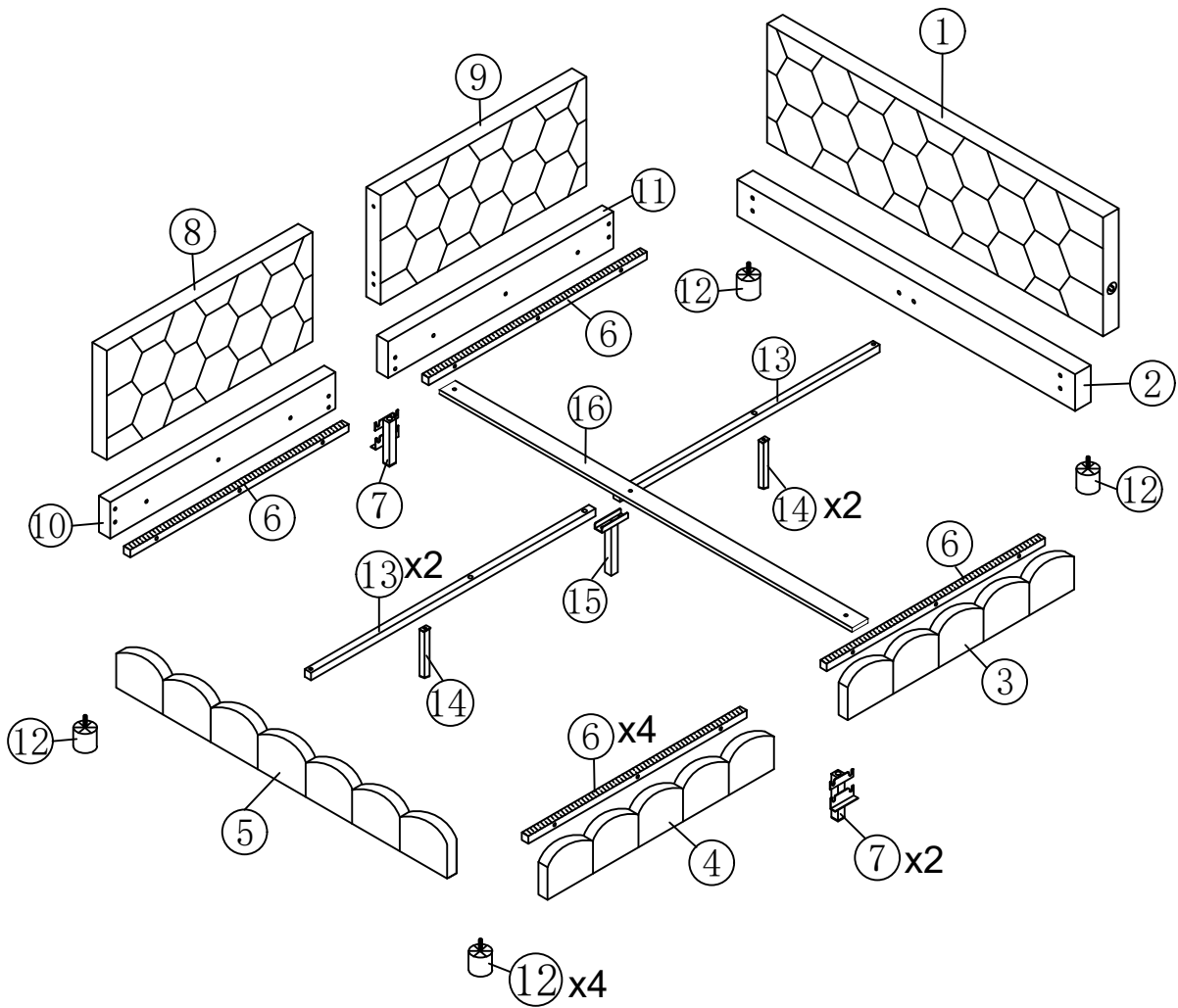



Detail View

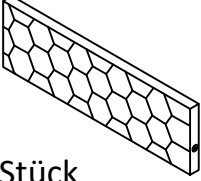
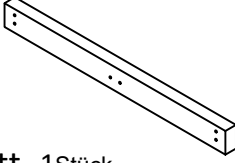
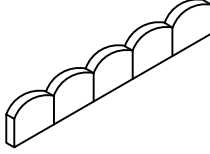

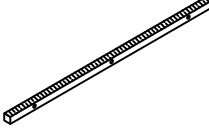
Liste der Einzelteile

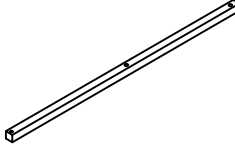
Hardwareliste+N636P195135

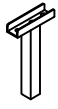
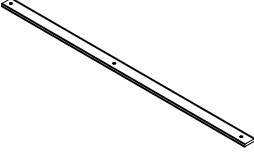
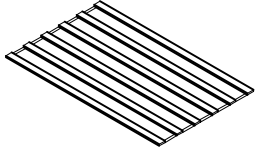



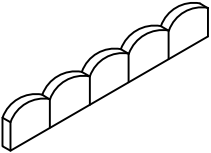
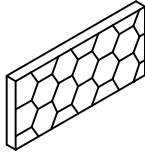
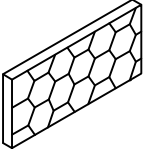
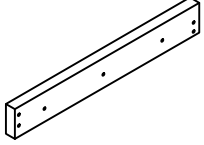
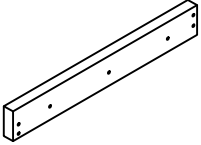





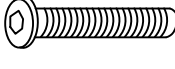

<p>1</p>  <p>Kopfteil-1Stück</p>	<p>2</p>  <p>Querbrett -1Stück</p>	<p>4</p>  <p>Seitenschienen-1Stück</p>
<p>5</p>  <p>Fußbrett-1Stück</p>	<p>6</p>  <p>Seitengitter Stützstange -4Stück</p>	<p>7</p>  <p>Seitenschienen Stützbeine-2Stück</p>
<p>12</p>  <p>Stützbeine des Bettes-4Stück</p>	<p>13</p>  <p>Mittelstützstange-2Stück</p>	<p>14</p>  <p>Mittleres Stützbein-2Stück</p>
<p>15</p>  <p>Verbundenes Stützbein-1Stück</p>	<p>16</p>  <p>Latte-1Stück</p>	<p>17</p>  <p>Latte-2Stück</p>

N636P195136

<p>3</p>  <p>Seitenschienen-1Stück</p>	<p>8</p>  <p>Obere Rückenlehne-1Stück</p>	<p>9</p>  <p>Obere Rückenlehne-1Stück</p>
<p>10</p>  <p>Untere Rückenlehne-1Stück</p>	<p>11</p>  <p>Untere Rückenlehne-1Stück</p>	

Hardwareliste

N636P195135

A  20*70mm	B  Ø8*50mm	C  Ø8*20mm
Inbusschlüssel(1Stück)	Schrauben(1Stück)	Schrauben(36Stück)
D  Ø8*40mm	E 	F  Ø3*16mm
Schrauben(33Stück)	"7"-Anschluss(4Stück)	Drei-Loch-Eisen(20Stück)
G 	H 	I 
Abstandshalter (13Stück)	Center support bar fittings (2Stück)	Buckle (10Stück)
J 	K 	ML 
LED (1Stück)	Netzteil (1Stück)	Scharnier (1Stück)
MR  Scharnier (1Stück)		

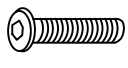
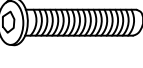
B  Ø8*50mm	C  Ø8*20mm	D  Ø8*40mm
Schrauben(1Stück)	Schrauben(36Stück)	Schrauben(33Stück)

DE:Bitte beachten Sie, dass die Formen der Schrauben B und C und D ähnlich sind. Bitte installieren Sie entsprechend der Anleitung und unterscheiden Sie sie!

UK>Please note that the shapes of screws B and C and D are similar. Please install according to the instructions and distinguish them!

FR:Notez que les vis B et C et D ont des formes similaires. Veuillez les installer en suivant les instructions pour les séparer!

DE: Vor dem Einbau die Schrauben in die Löcher stecken und festziehen, aber nicht bis 100%, 70% bis 80% anziehen reicht aus. Schließlich, nachdem alle Schrauben installiert sind, ziehen Sie alle Schrauben auf 100%.

Wenn Sie auf diese Probleme stoßen, wie z. B. Fehlausrichtung der Löcher oder Unfähigkeit, bestimmte Teile zu installieren, überprüfen Sie bitte, ob die Schrauben korrekt verwendet werden und passen Sie die Dichtigkeit der Schrauben an.

UK: Before installation, insert the screws into the holes and tighten them, but do not tighten them to 100%, 70% to 80% is sufficient. Finally, after all screws are installed, tighten all screws to 100%.

If you encounter these issues, such as if the holes cannot be aligned or some parts cannot be installed, please check if the screws are used correctly and adjust the tightness of the screws.

FR: Insérer la vis dans le trou avant la fin de l'assemblage, serrer la vis, mais ne pas serrer à 100%, 70% ~ 80% est correct. Enfin, une fois que toutes les vis sont bien serrées, toutes les vis sont serrées à 100%.

Si vous rencontrez ces problèmes, par exemple si les trous ne sont pas alignés ou si certaines pièces ne peuvent pas être montées, vérifiez que les vis sont utilisées correctement et Ajustez leur serrage.

Hinweis: Wir empfehlen Ihnen, Ihr Bett im ebenen Boden aufzubauen.



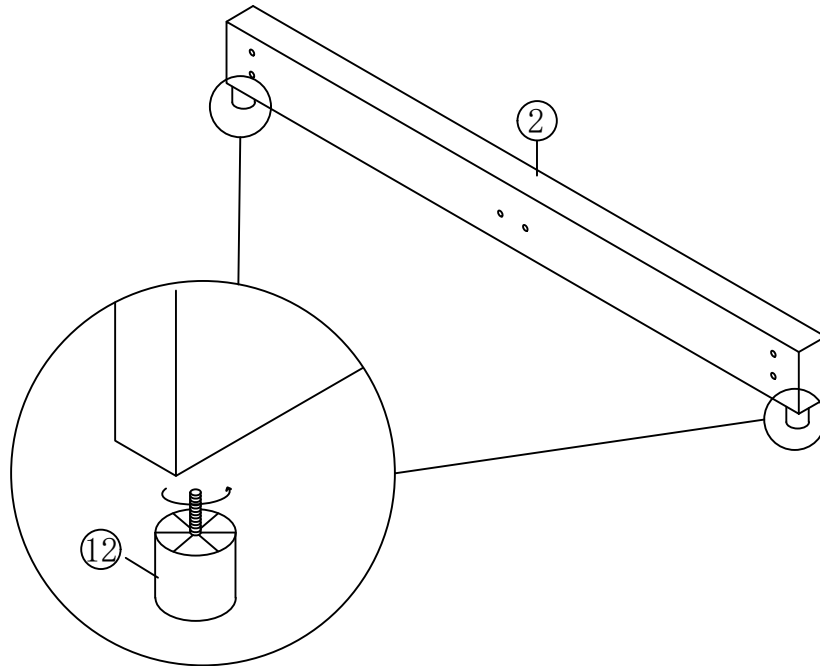

Schritt 1

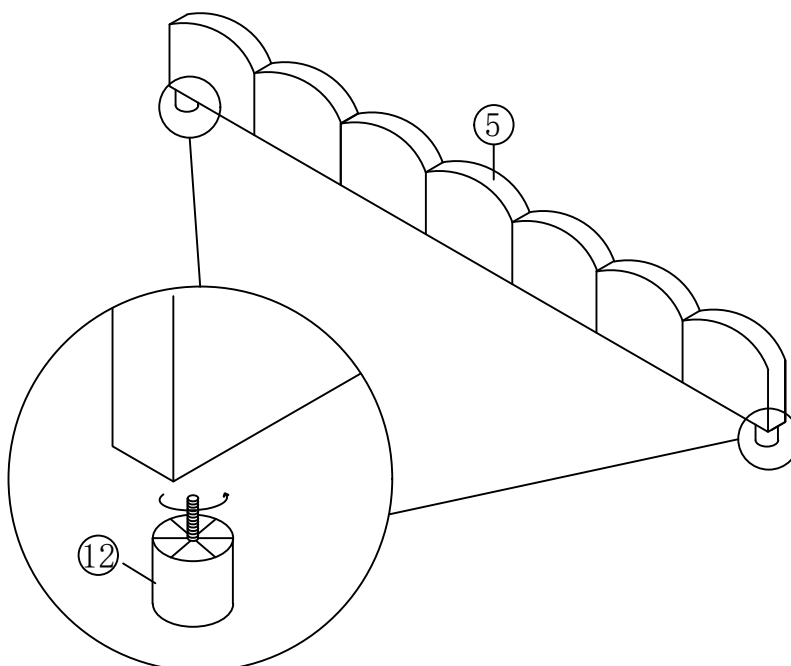

Schritt 2





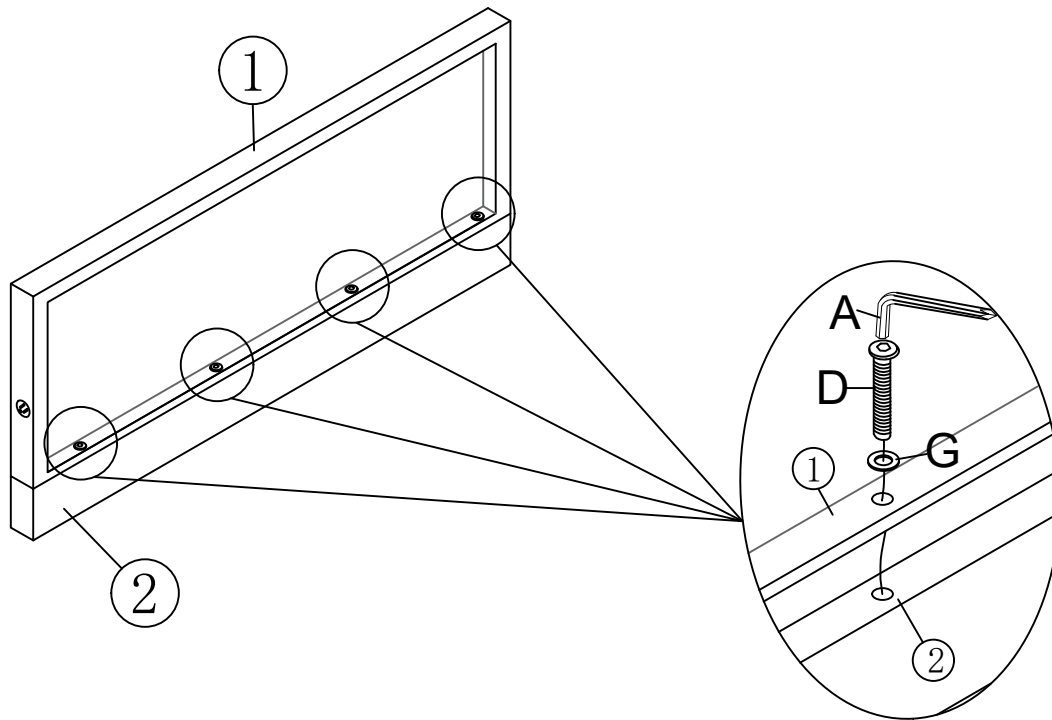

Schritt 3

<p>A</p> 	<p>D</p>  <p>M8x40mm</p>	<p>B</p>  <p>Ø8*50mm</p>	<p>C</p>  <p>Ø8*20mm</p>	<p>G</p> 
<p>4Stück</p>				<p>4Stück</p>





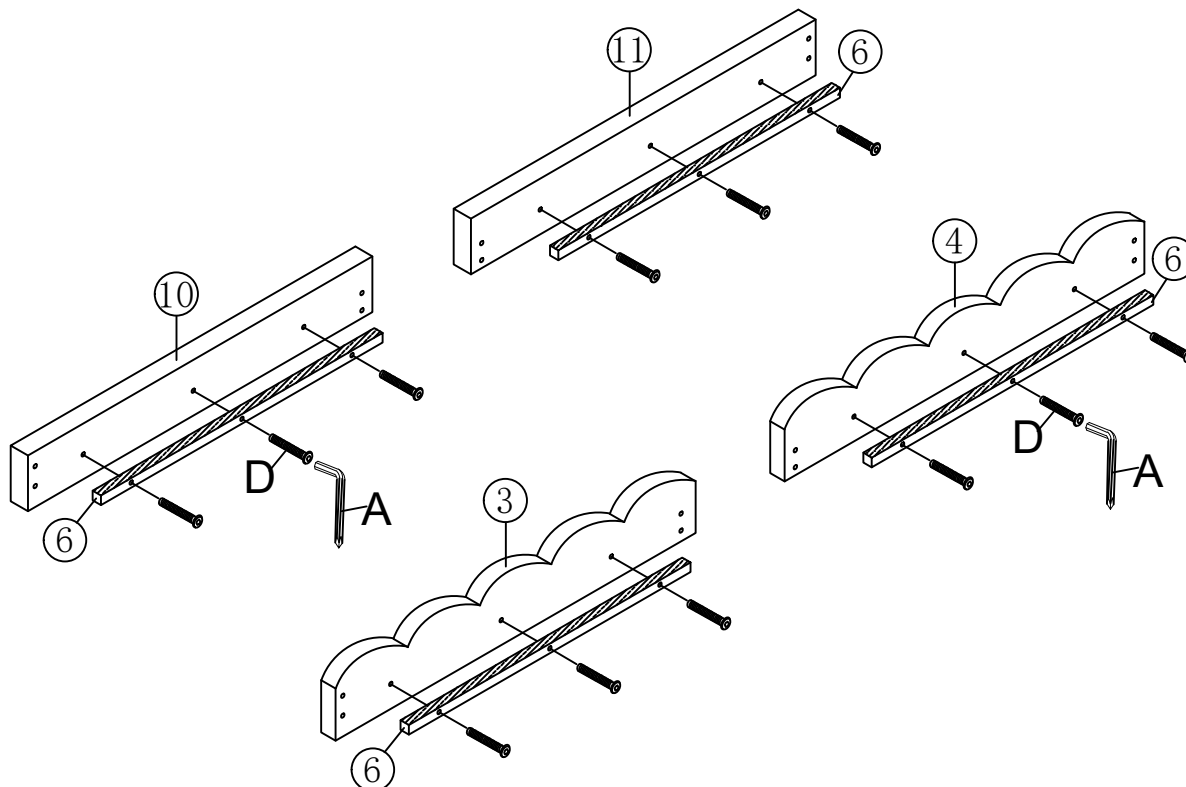

Schritt 4

<p>A</p> 	<p>D</p>  <p>M8x40mm</p>	<p>B</p>  <p>Ø8*50mm</p>	<p>C</p>  <p>Ø8*20mm</p>
<p>12Stück</p>			





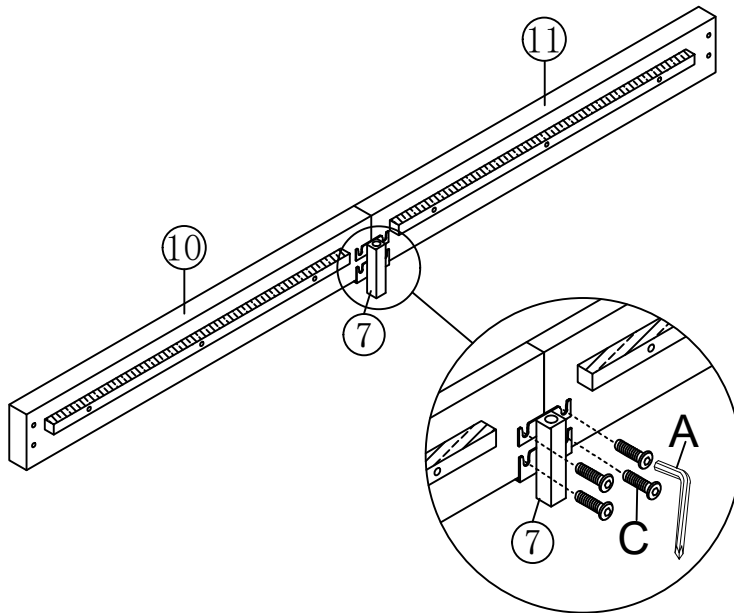

Schritt 5

A	C	B	D
	 Ø8*20mm	 Ø8*50mm	 M8*40mm
4Stück			





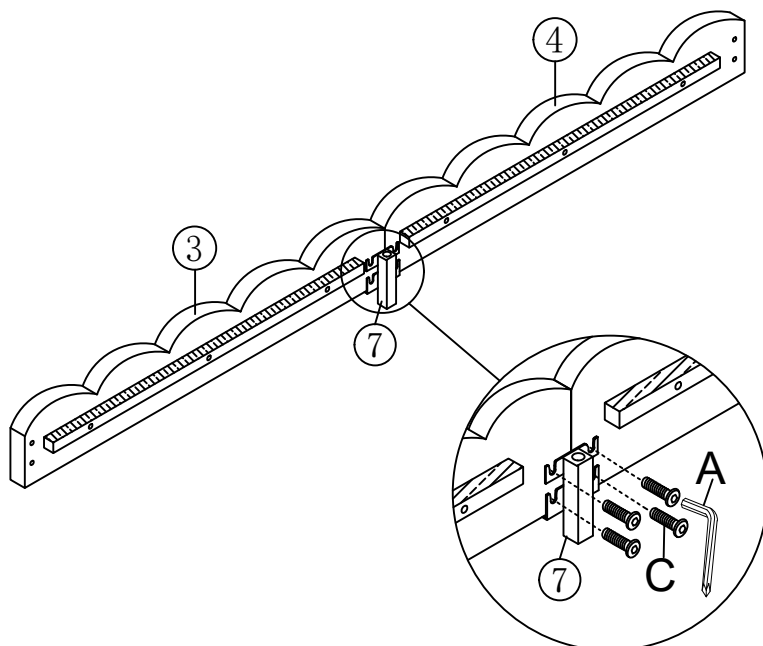

Schritt 6

A	C	B	D
	 Ø8*20mm	 Ø8*50mm	 M8*40mm
4Stück			





Schritt 7

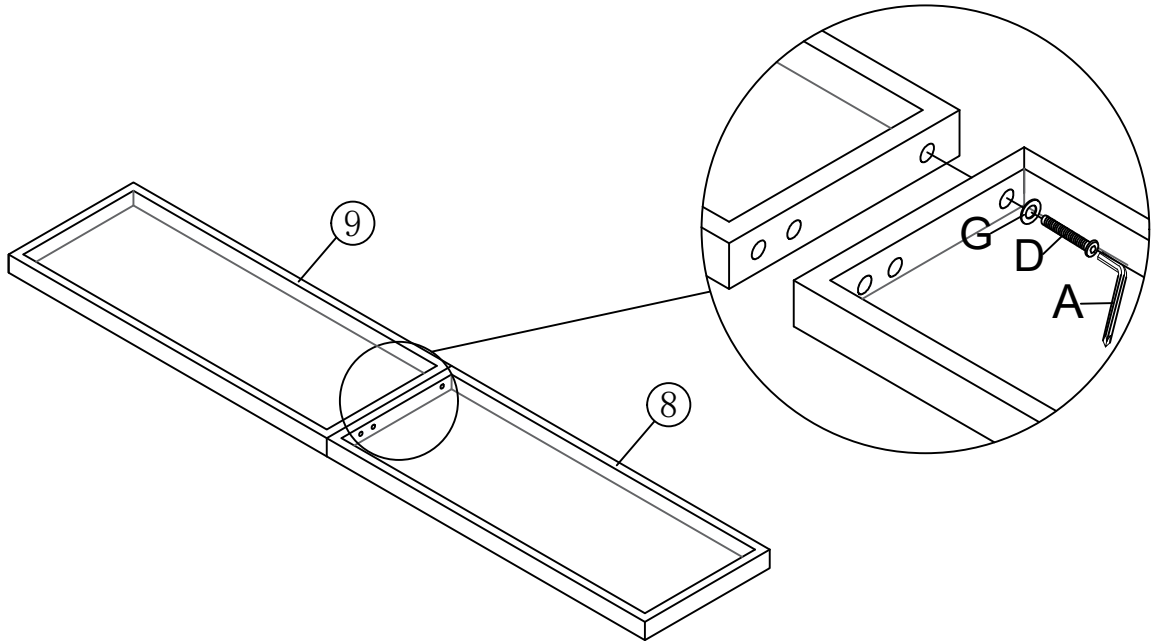

A	D	B	C	G
	 M8X40mm 1Stück	 Ø8*50mm	 Ø8*20mm	 1Stück

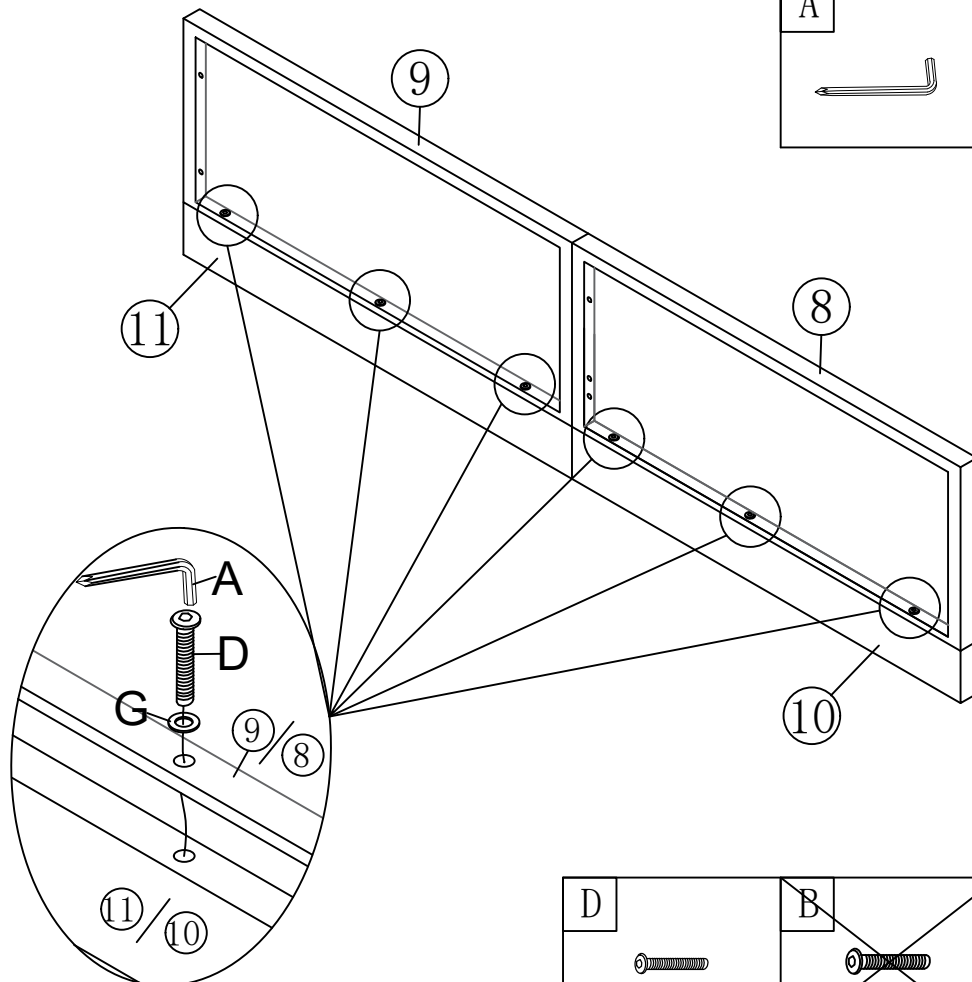

Schritt 8

A	G
	 6Stück



D	B	C
 M8X40mm 6Stück	 Ø8*50mm	 Ø8*20mm

Schritt 9

A	C	D	B	ML
	 M8X20mm	 M8X40mm		
	6Stück	2Stück		1Stück

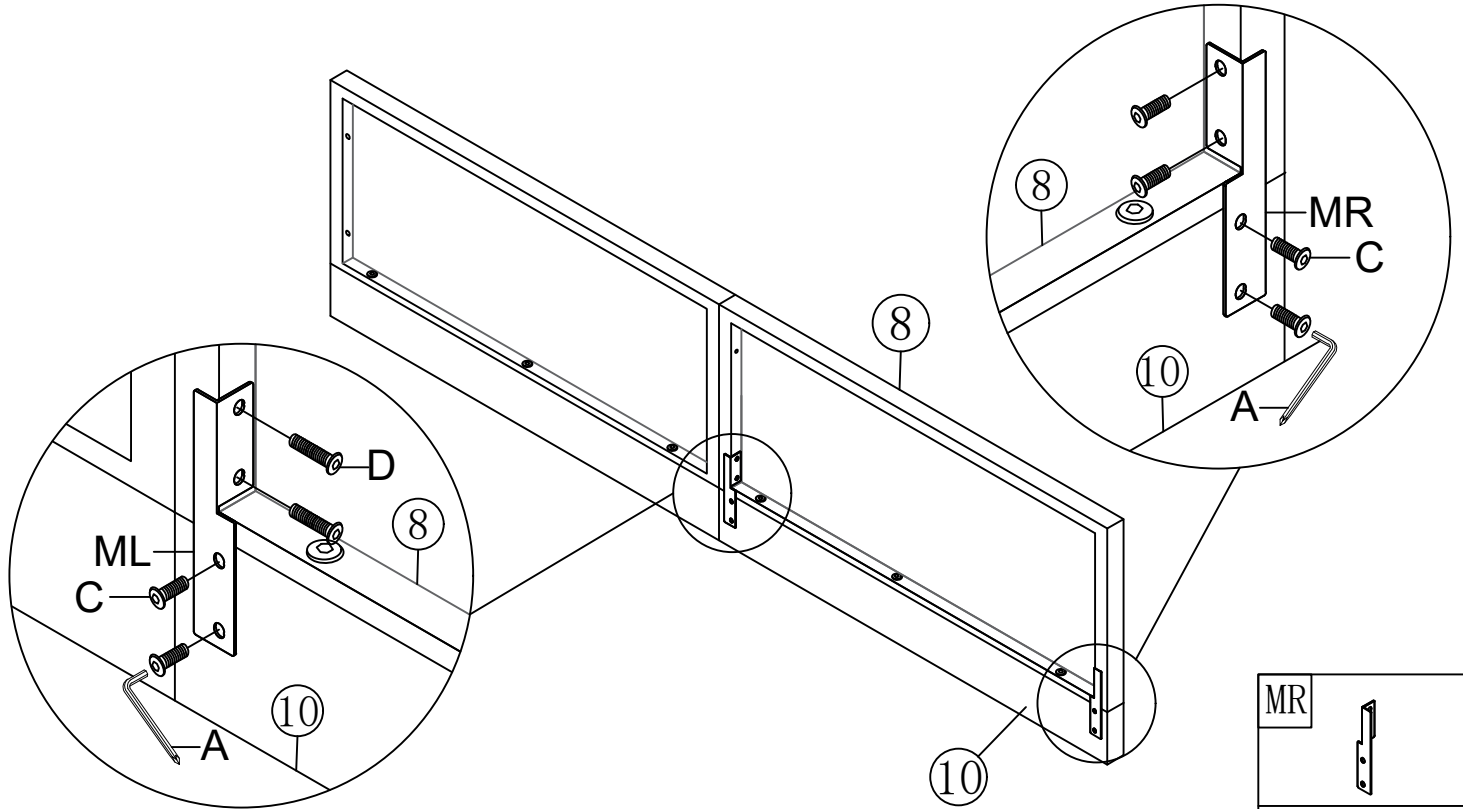



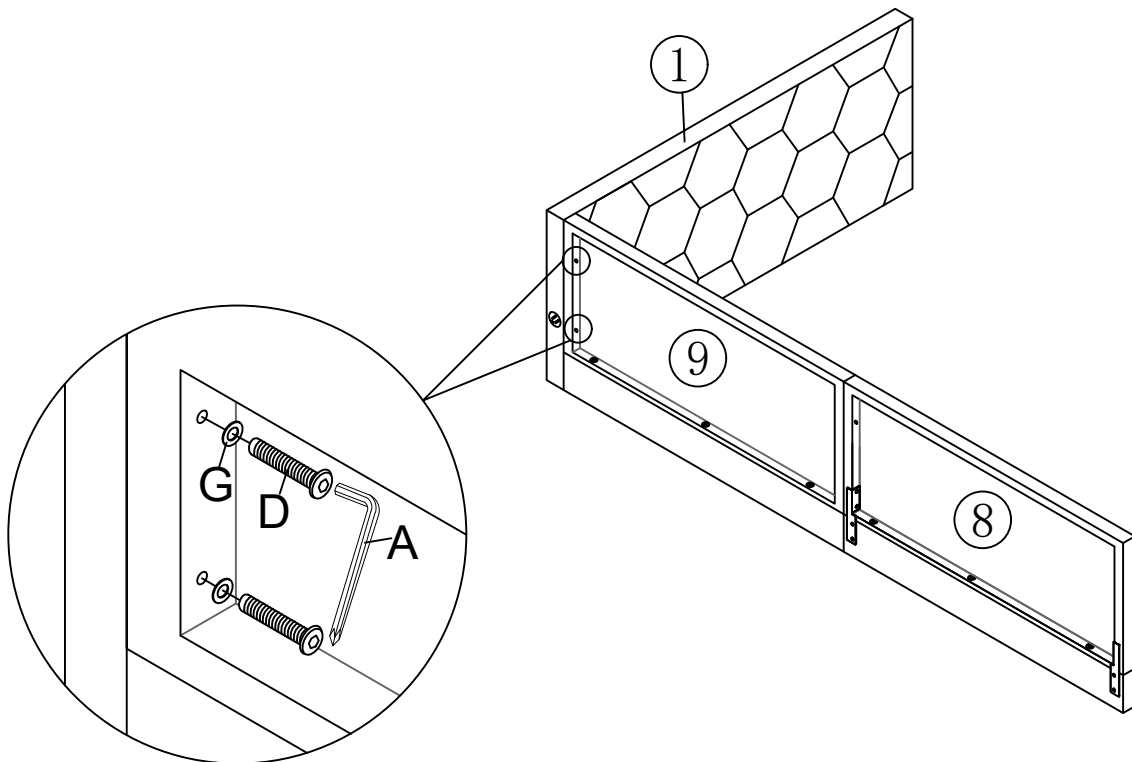

MR
1Stück

Schritt 10

A	D	B	C	G
	 M8X40mm			
	2Stück			2Stück





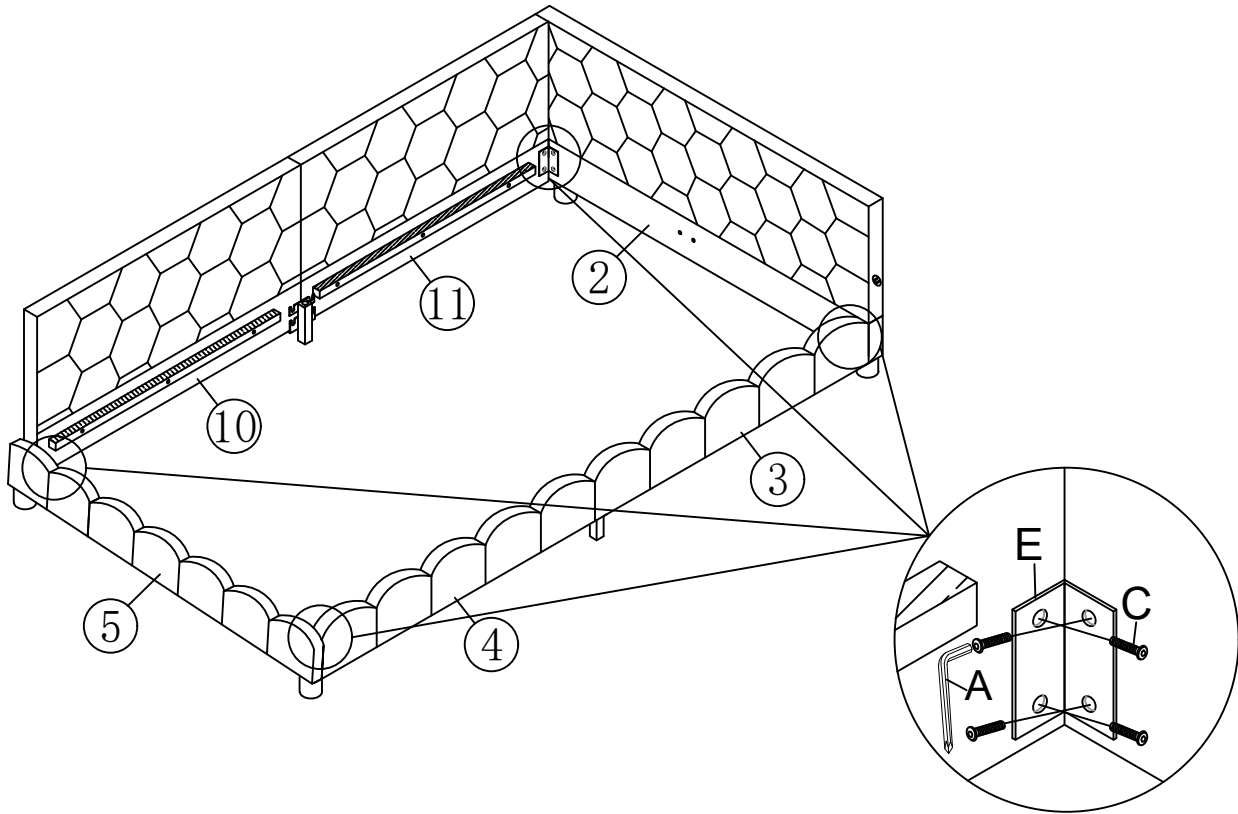

Schritt 11

A	C	B	D	E
	 M8X20mm 16Stück	 $\varnothing 8 \times 50\text{mm}$	 M8X40mm	 4Stück





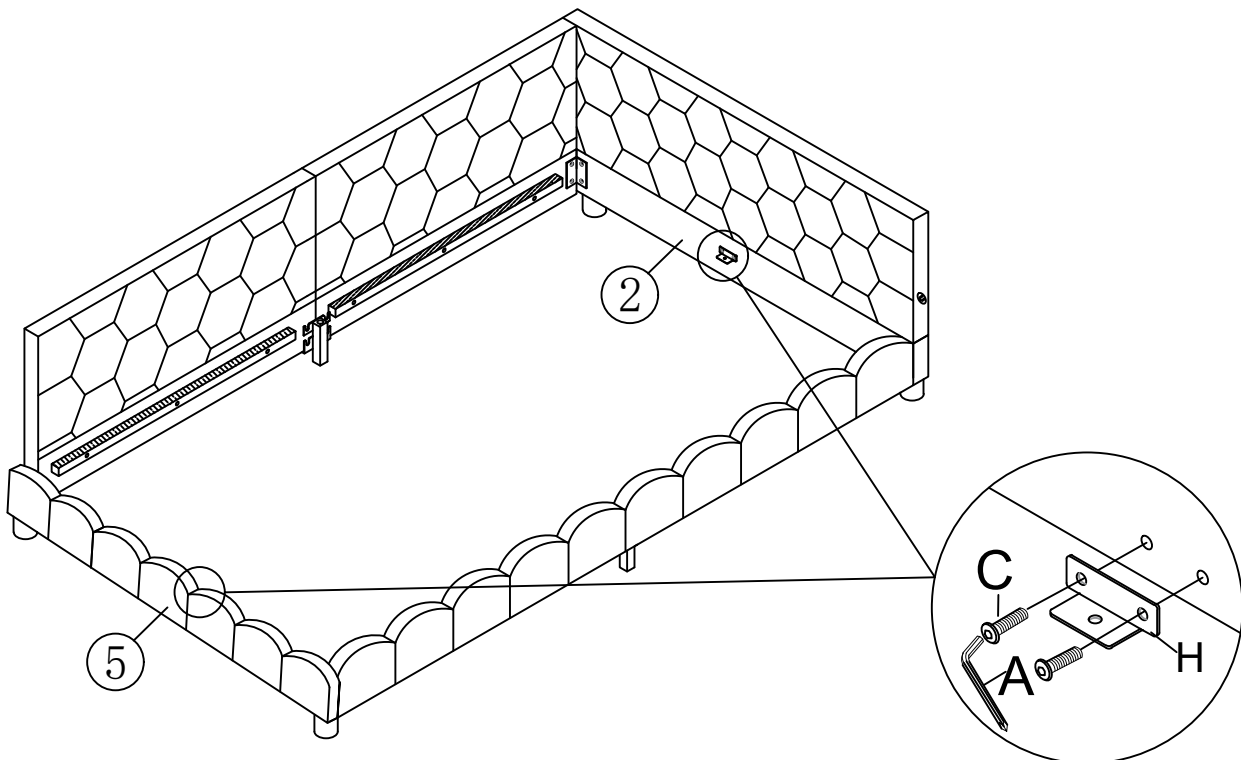

Schritt 12

A	C	B	D	H
	 M8X20mm 4Stück	 $\varnothing 8 \times 50\text{mm}$	 M8X40mm	 2Stück





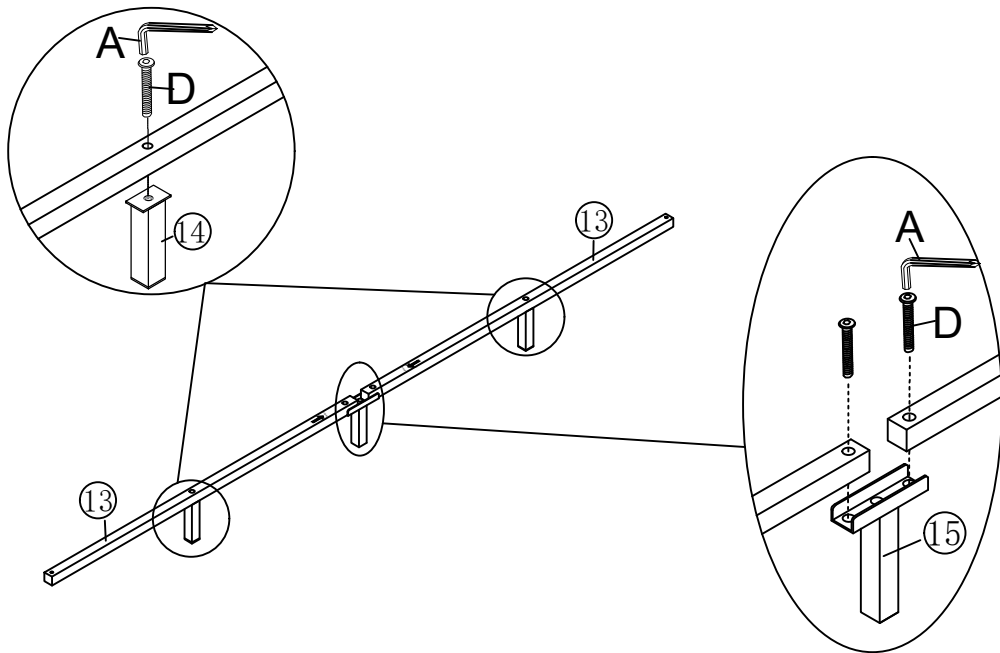

Schritt 13

A	D	B	C
	 M8X40mm	 Ø8*50mm	 Ø8*20mm
4Stück			



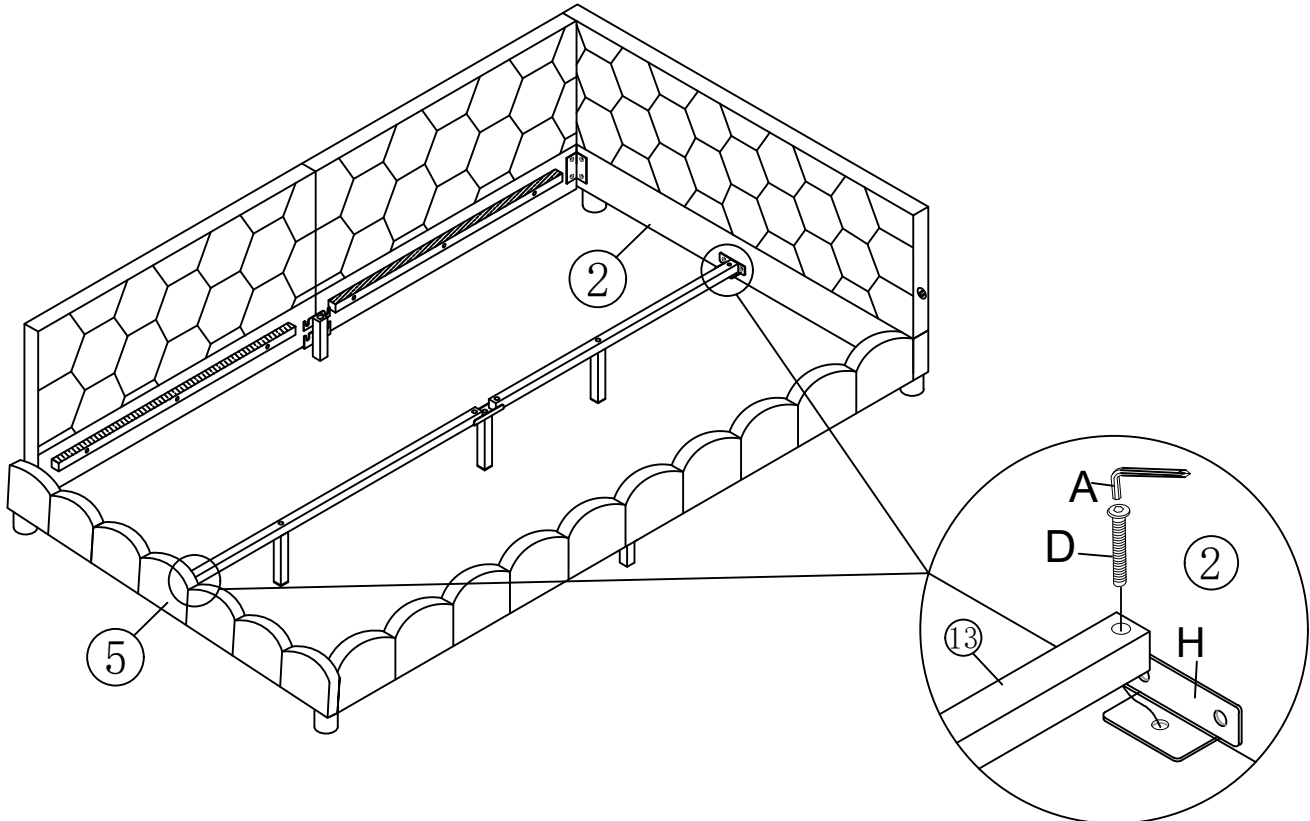

Schritt 14

A	D	B	C
	 M8X40mm	 Ø8*50mm	 Ø8*20mm
2Stück			





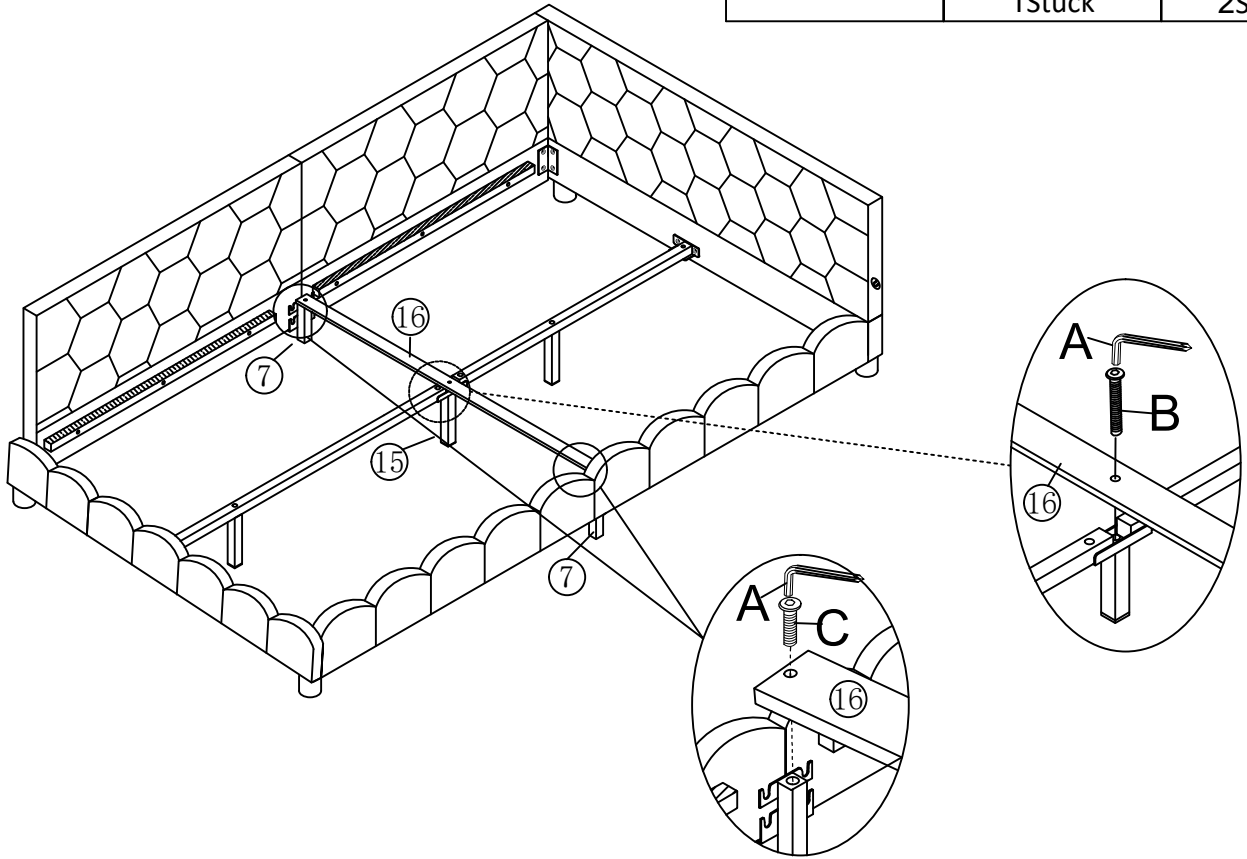

Schritt 15

<p>A</p> 	<p>B</p>  <p>M8X50mm</p> <p>1Stück</p>	<p>C</p>  <p>M8X20mm</p> <p>2Stück</p>
---	---	---



Schritt 16

<p>A</p> 	<p>F</p>  <p>M3X16mm</p> <p>20Stück</p>	<p>I</p>  <p>10Stück</p>	<p>J</p>  <p>1Stück</p>
--	---	---	--

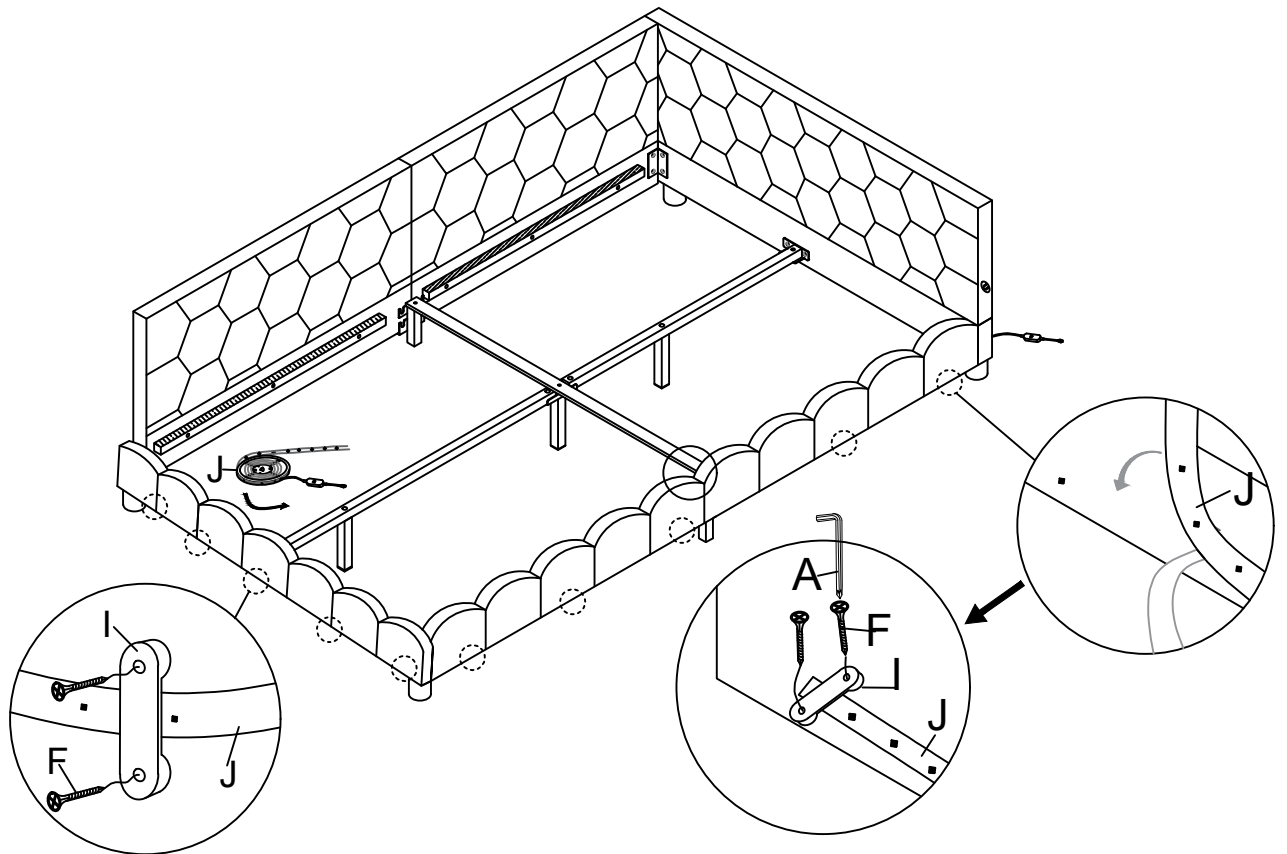

Schritt 17

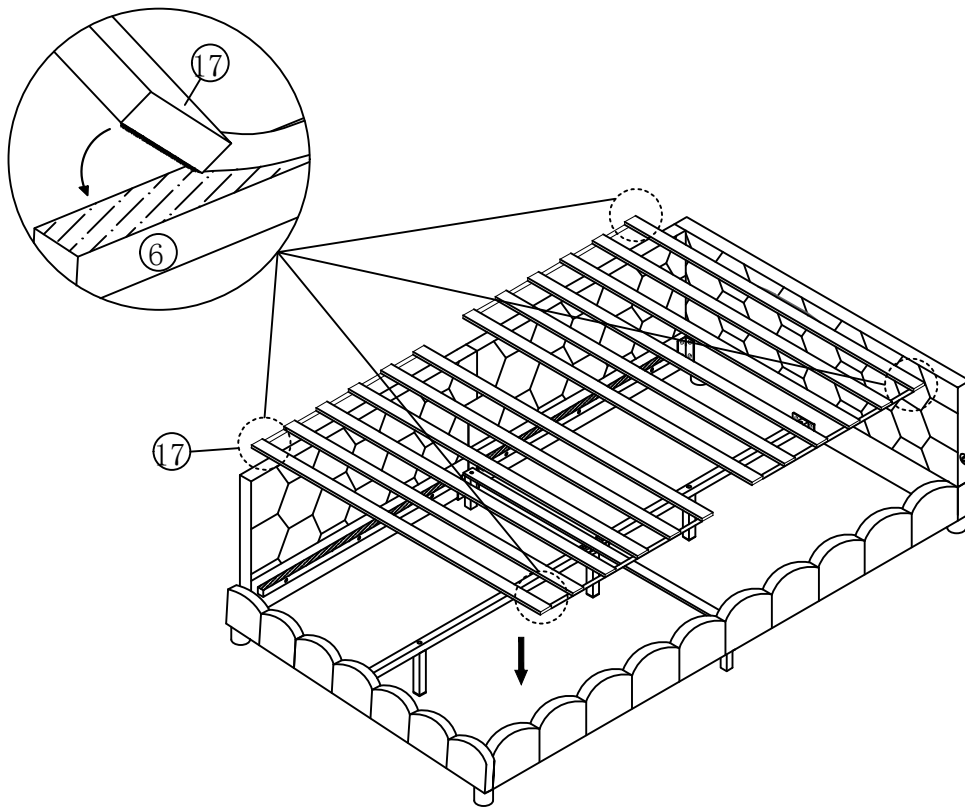

Schritt 18

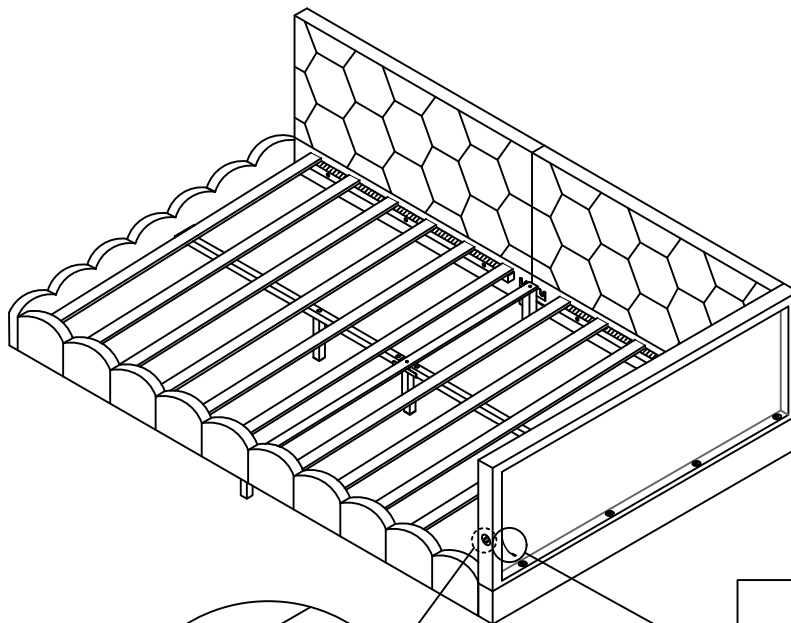

K



1Stück

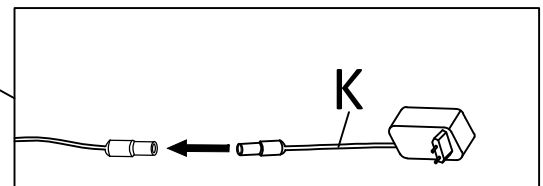
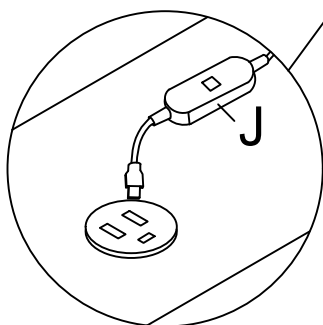

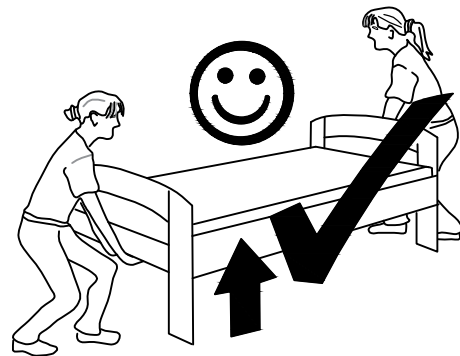
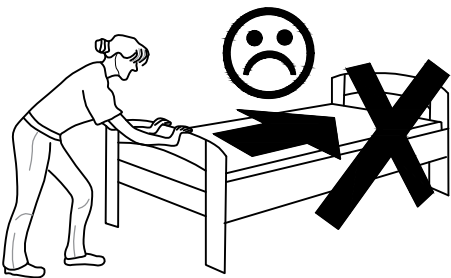
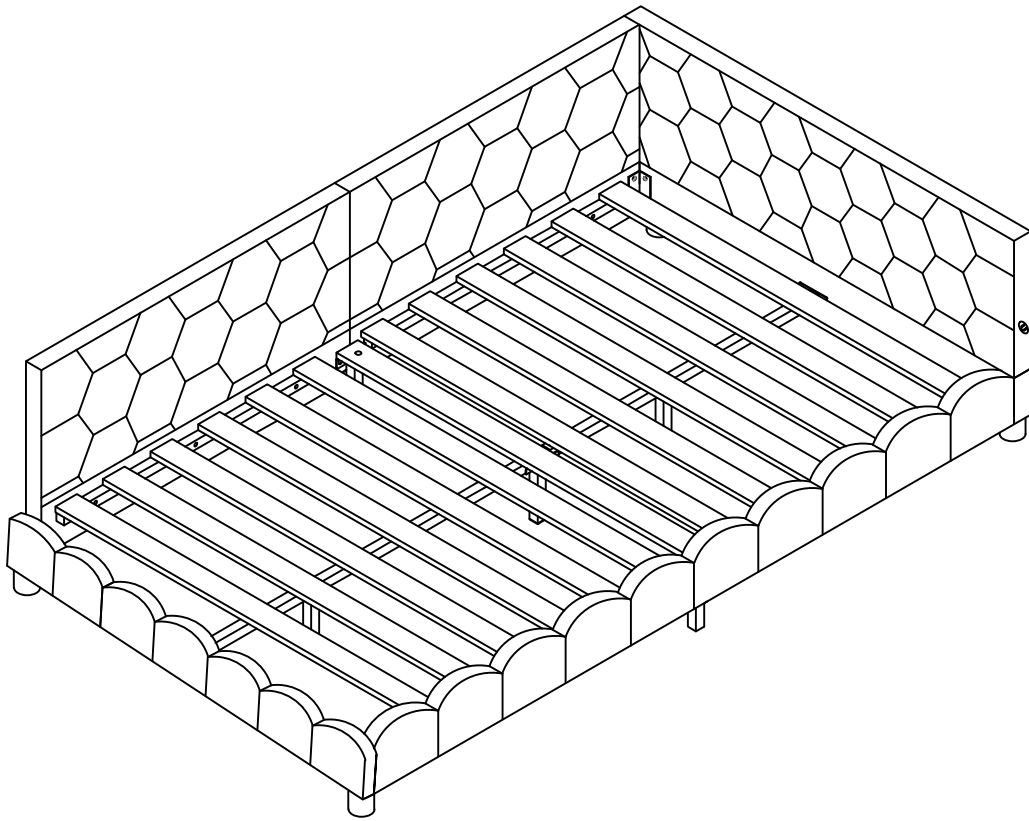

LED Bluetooth controller Features

Caractéristiques du contrôleur Bluetooth LED

LED Bluetooth Controller Eigenschaften

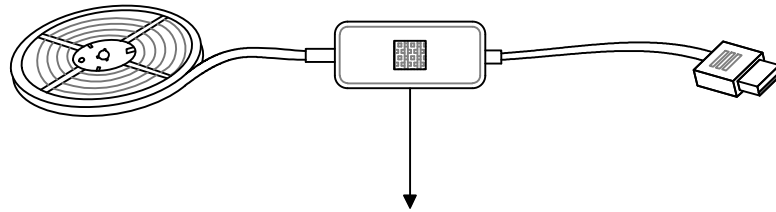

NOTICE:

Please scan the QR code to download the APP to control the color of the light strip.
Please refer to the following instructions for details.

Bitte scannen Sie den QR-Code, um die APP herunterzuladen, um die Farbe des Einzelheiten entnehmen Sie bitte der folgenden Anleitung.

Veillez scanner le code QR pour télécharger l'application pour contrôler la couleur de la bande lumineuse.

Veillez consulter les instructions ci-dessous pour plus de détails.

Click to show the lamp list

Cliquez pour afficher la liste des lumières
Klicken Sie, um die Liste der Lichter anzuzeigen

Switch the color wheel
Basculer la roue des couleurs
Farbrad wechseln

Display the RGB value Click to manual
Afficher les valeurs RVB Cliquez pour manuellement
RGB-Werte anzeigen Klicken Sie manuell

Adjustment view
Ajuster la vue
Ansicht anpassen

Click to shift the interface

Cliquez sur l'interface mobile
Klicken Sie, um die Schnittstelle zu wechseln

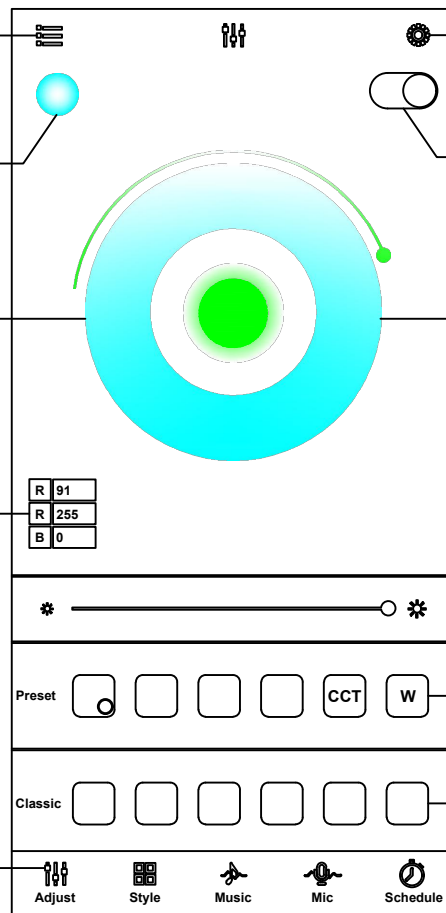

Click to display setting view

Cliquez pour afficher la vue des paramètres
Klicken Sie, um die Einstellungsansicht anzuzeigen

Lamp switch button
Bouton interrupteur lumière
Taste für Lichtschalter

Adjust the color
Ajuster la couleur
Farbe anpassen

Click square icon to
Cliquez sur l'icône du carré pour
Klicken Sie auf das quadratische Symbol, um

LED Bluetooth controller Features

Caractéristiques du contrôleur Bluetooth LED

LED Bluetooth Controller Eigenschaften

Product Features :

LED Bluetooth controller is directly via mobile phone control remote distance can reach 20m without the need to set up, easy to connect open the software within 5 seconds you can automatically connect the controller · Flow the rhythm of the music changes · Group control · Brightness, speed addition and subtraction · Maximum can be 10 meters RGB(W) strip · The software shows that the text is based on the language of the mobile phone set up automatic transformation of Chinese and English Animation Effect: · Colorful gradient ● All kinds of monochrome, double color gradient ● All kinds of monochrome, double color, colorful flashing Follow the rhythm of the music changes
Product Parameters: · Bluetooth: BLE V4.2 · Input Voltage: 4.5~26V · Working Temp: -25~75
· Size: 43*22*11mm · Weight: 30g · Max Power: 144W(24V)

Caractéristiques du produit:

Le contrôleur Bluetooth LED est contrôlé directement via le téléphone portable La distance à distance peut atteindre 20m Aucun réglage requis, connexion facile Ouvrez le logiciel pour se connecter automatiquement au contrôleur dans les 5 secondes · Changement de rythme de la musique fluide · Contrôle de groupe · Luminosité, augmentation et diminution de vitesse · Jusqu'à 10 mètres barres RVB (W) · Le logiciel affiche le texte Convertir automatiquement les effets d'animation chinois et anglais selon les paramètres de langue du téléphone portable: · Dégradé coloré ● Divers dégradés monochrome et bicolore ● Divers clignotements monochrome, bicolore et colorés suivent le rythme de la musique changes Paramètres du produit: · Bluetooth: BLE V4.2 · Tension d'entrée: 4,5 ~ 26 V · Température de fonctionnement: -25 ~ 75 · Taille: 43 * 22 * 11 mm · Poids: 30 g · Puissance maximale: 144 W (24 V)

Produktmerkmale:

Der LED-Bluetooth-Controller wird direkt über das Mobiltelefon gesteuert. Die Fernentfernung kann bis zu 20 m erreichen. Keine Einstellung erforderlich, einfach zu verbinden. Öffnen Sie die Software, um den Controller automatisch innerhalb von 5 Sekunden zu verbinden · Rhythmusänderungen der fließenden Musik · Gruppensteuerung · Helligkeit, Geschwindigkeitserhöhung und -verringerung · Maximal 10 Meter RGB(W)-Streifen · Software zeigt Text, um den Animationseffekt zwischen Chinesisch und Englisch entsprechend den Spracheinstellungen des Mobiltelefons automatisch umzuwandeln: · Bunter Farbverlauf ● Verschiedene einfarbige und zweifarbige Farbverläufe ● Verschiedene einfarbige, zweifarbige und farbenfrohe Blinkungen folgen dem Rhythmus der Musik changes Produktparameter: · Bluetooth: BLE V4.2 · Eingangsspannung: 4,5 ~ 26 V · Betriebstemperatur: -25 ~ 75 · Größe: 43 * 22 * 11 mm · Gewicht: 30 g · Maximale Leistung: 144 W (24 V)

Verification of Compliance

Verification No.:	MK24030235P01-S01
Name and address of Applicant:	Shenzhen Hongzhengyu Technology Co., LTD Shenzhen baoan district rock street industrial science and technology industrial park of 2 Haitian lanyu 3 5 floor of A
Name and address of Manufacturer:	Shenzhen Hongzhengyu Technology Co., LTD Shenzhen baoan district rock street industrial science and technology industrial park of 2 Haitian lanyu 3 5 floor of A
Product name:	LED Lamp Strip
Rated:	DC5V, 2A, Max.10W HZY-2835-120D-12V, HZY-2835-30D-5V, HZY-2835-60D-5V, HZY-2835-120D-5V, HZY-2835-60D-12V, HZY-2835-60D-24V, HZY-2835-120D-24V, HZY-2835RGB-60D-5V, HZY-2835RGB-60D-12V, HZY-5050-30D-5V, HZY-5050-60D-5V, HZY-5050-30D-12V, HZY-5050-60D-12V, HZY-5050-60D-24V, HZY-5050RGB-30D-5V, HZY-5050RGB-60D-5V, HZY-5050RGB-30D-12V, HZY-5050RGB-60D-12V, HZY-5050RGB-60D-24V
Product model(s):	
Product trademark:	N/A

This verification confirms that the product meets the requirements of the following standard.
The conformity was demonstrated based on following standard(s) listed by European Commission as harmonized with LVD Directive 2014/35/EU.

EN IEC 60598-2-1:2021;
EN IEC 60598-1:2021+ A11:2022

The verification has been carried out in accordance with individual rules and conditions agreed with the applicant. Evaluation has been carried out in accordance with:

Test report(s) No.:	MK24030235P01-S01
Test conducted by:	TMC Testing Services (Shenzhen) Co., Ltd.
Verification issue date:	April 9, 2024

Notes:

This verification refers to the above mentioned product and its conformity in regards of above mentioned standard(s) was proven on test sample.

This verification does not imply meeting all essential requirements, assessment of the series-production or any other restricted Notified Bodies conformity assessment procedure appropriate for the product.

This verification holder shall use this verification in connection to Verification of Compliance and technical data relevant for the product the verification was issued.

TMC Testing Services (Shenzhen) Co., Ltd.

t:86-755-86642861 cert@tmc-lab.com www.tmc-lab.com

1/F., Block A, Xinshidai Gongrong Industrial Park, No. 2, Shihuan Road, Shilong Community, Shiyan Street, Baoan District, Shenzhen, China



Dawen Xu

Lab Director
Dawen Xu



Verification of Compliance

Verification No.:	MK24030235P01-S01
Name and address of Applicant:	Shenzhen Hongzhengyu Technology Co., LTD Shenzhen baoan district rock street industrial science and technology industrial park of 2 Haitian lanyu 3 5 floor of A
Name and address of Manufacturer:	Shenzhen Hongzhengyu Technology Co., LTD Shenzhen baoan district rock street industrial science and technology industrial park of 2 Haitian lanyu 3 5 floor of A
Product name:	LED Lamp Strip
Rated:	DC5V, 2A, Max.10W HZY-2835-120D-12V, HZY-2835-30D-5V, HZY-2835-60D-5V, HZY-2835-120D-5V, HZY-2835-60D-12V, HZY-2835-60D-24V, HZY-2835-120D-24V, HZY-2835RGB-60D-5V, HZY-2835RGB-60D-12V, HZY-5050-30D-5V, HZY-5050-60D-5V, HZY-5050-30D-12V, HZY-5050-60D-12V, HZY-5050-60D-24V, HZY-5050RGB-30D-5V, HZY-5050RGB-60D-5V, HZY-5050RGB-30D-12V, HZY-5050RGB-60D-12V, HZY-5050RGB-60D-24V
Product model(s):	
Product trademark:	N/A

This verification confirms that the product meets the requirements of the following standard.
The conformity was demonstrated based on following standard(s) listed by European Commission as harmonized with LVD Directive 2014/35/EU.

EN IEC 60598-2-1:2021;
EN IEC 60598-1:2021+ A11:2022

The verification has been carried out in accordance with individual rules and conditions agreed with the applicant. Evaluation has been carried out in accordance with:

Test report(s) No.:	MK24030235P01-S01
Test conducted by:	TMC Testing Services (Shenzhen) Co., Ltd.
Verification issue date:	April 9, 2024

Notes:

This verification refers to the above mentioned product and its conformity in regards of above mentioned standard(s) was proven on test sample.

This verification does not imply meeting all essential requirements, assessment of the series-production or any other restricted Notified Bodies conformity assessment procedure appropriate for the product.

This verification holder shall use this verification in connection to Verification of Compliance and technical data relevant for the product the verification was issued.

TMC Testing Services (Shenzhen) Co., Ltd.

t:86-755-86642861 cert@tmc-lab.com www.tmc-lab.com

1/F., Block A, Xinshidai Gongrong Industrial Park, No. 2, Shihuan Road, Shilong Community, Shiyan Street, Baoan District, Shenzhen, China



Dawen Xu

Lab Director
Dawen Xu





CERTIFICATE OF CONFORMITY

Electromagnetic Compatibility (EMC) Directive 2014/30/EU

This Certificate of Conformity is hereby issued to the product designated below:

Certificate No. : 24EP01101E01
Report No. : EP2401101E01
Date Issue. : 2024-04-28
Applicant's name : Guangdong Sangu Technology Co., Ltd
Address : 402, Chuangye building, 8-28, Shaqi community Central Road, Xinqiao street, Bao'an District, Shenzhen.
Manufacturer's name : Guangdong Sangu Technology Co., Ltd
Address : 402, Chuangye building, 8-28, Shaqi community Central Road, Xinqiao street, Bao'an District, Shenzhen.
Product Description : POWER ADAPTER
Model(s)/Type References : SG-050yyyyz, GA-050yyyyz, GAT-050yyyyz, HZ-050yyyyz, SG-050yyyyAz, GA-050yyyyAz, GAT-050yyyyAz, HZ-050yyyyAz, SG-050yyyyAzC, GA-050yyyyAzC, GAT-050yyyyAzC, HZ-050yyyyAzC, SG-xxxyyyy12Az (xxx, yyyy, z are variables, appendix for details)
Parameters : See appendix for details
Standard(s) : EN 55032:2015+A11:2020+A1:2020
EN 55035:2017+A11:2020
EN IEC 61000-3-2:2019+A1:2021
EN 61000-3-3:2013+A1:2019+A2:2021

On the basis of the referenced test report(s), sample(s) tested of the above product have been found to comply with the standards harmonized with the directives listed on this verification at the time the tests were carried out. Other standards and Directives may be relevant to the product. This verification is part of the full test report(s) and should be read in conjunction with it(them).

Once compliance with all product relevant CE mark directives are verified, including any relevant e.g. risk assessment and production control, the manufacturer may indicate compliance by signing a Declaration of Conformity themselves and applying the mark to products identical to the tested sample(s).

Approved By

.....
Eric Liu
Director of engineering department



Dongguan Pubiao Testing Technology Co., Ltd

No. 3, 1/F., Building A, No.30, Minghua Road, Juzhou, Shijie, Dongguan, Guangdong, China

Tel: +86 769 81813516 E-mail: service@pubiaotest.com Web: www.pubiaotest.com

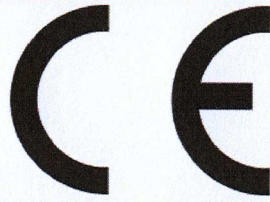

CERTIFICATE OF CONFORMITY

Electromagnetic Compatibility (EMC) Directive 2014/30/EU

Appendix of Certificate No.: 24EP01101E01

Table A: Definition of variables

Variable	Range of variable	Content
xxx	050-240	3 digits, indicates 10 times of output voltage in V and in step of 0.1V. eg. 050=5.0V, 240=24.0V.
yyyy	0100-2100	4 digits, indicates 1000 times of output current in A and in step of 0.01A. eg. 0100=0.1A, 2100=2.1A.
z	E, B	One capital letter representing the plug type for different countries. E represents European plug and Russian plug; B represents British plug.

Table B: Model list and input / output ratings











Model	Rated input	Rated output			Transformer
		Voltage range (VDC)	Current range (A)	Max. Power (W)	
SG-050yyyyz, GA-050yyyyz, GAT-050yyyyz, HZ-050yyyyz, SG-050yyyyAz, GA-050yyyyAz, GAT-050yyyyAz, HZ-050yyyyAz, SG-050yyyyAzC, GA-050yyyyAzC, GAT-050yyyyAzC, HZ-050yyyyAzC,	100-240V~, 50/60Hz, 0.3A Max.	5.0	0.1-2.0	10.0	EF1510
SG-xxxxyyy12Az	100-240V~, 50/60Hz, 0.6A Max.	5.0-5.5	0.10-2.1	11.55	EF1510-1
		5.6-12.0	0.10-2.0	12.00	
		12.1-24.0	0.10-1.0	12.00	



Dongguan Pubiao Testing Technology Co., Ltd

No. 3, 1/F., Building A, No.30, Minghua Road, Juzhou, Shijie, Dongguan, Guangdong, China

Tel: +86 769 81813516 E-mail: service@pubiaotest.com Web: www.pubiaotest.com

Importeur	Decobus Handel GmbH
Adresse	Innungsstraße 9, 2124Buchholz,Deutschland
Email/URL	https://www.decobusgroup.de
Hersteller	Shenzhen Aoli Optoelectronics Co.,LTD
Adresse	5th Floor, Building 3, Haitian Lanyu Science and Technology Park, Shilong Community, Shiyan Street, Bao'an District, Shenzhen
Email/URL	https://aoligd.1688.com/
Partienummer	Embedded USB port
Hergestellt in	China
	Decobus Handel GmbH Innungsstraße 9,21244Buchholz,Deutschland www.decobusgroup.de
 	Product Name:Embedded USB port Model: 12V A+C Rated voltage:DC12V Rated frequency:50-60HZ Power:10W
Importeur	Decobus Handel GmbH
Adresse	Innungsstraße 9, 21244 Buchholz,Deutschland
Email/URL	https://www.decobusgroup.de
Hersteller	Shenzhen Hongzhengyu Technology Co., LTD
Adresse	Shenzhen baoan district rock street industrial science and technology industrial park of 2 Haitian lanyu 3 5 floor of A
Email/URL	https://aoligd.1688.com/
Partienummer	LED light strip
Hergestellt in	China
	Decobus Handel GmbH Innungsstraße 9, 21244 Buchholz,Deutschland www.decobusgroup.de
Importeur	Decobus Handel GmbH
Adresse	Innungsstraße 9, 21244 Buchholz,Deutschland
Email/URL	https://www.decobusgroup.de
Hersteller	Shenzhen Hongzhengyu Technology Co., LTD
Adresse	Shenzhen baoan district rock street industrial science and technology industrial park of 2 Haitian lanyu 3 5 floor of A
Email/URL	https://aoligd.1688.com/
Partienummer	LED light strip
Hergestellt in	China
	Decobus Handel GmbH Innungsstraße 9, 21244 Buchholz,Deutschland www.decobusgroup.de
 	Product Name:LED light strip Model:HZY-5050RGB-30D-12V Rated voltage:DC12V Rated frequency:50-60HZ Power:5W/M
Importeur	Decobus Handel GmbH
Adresse	Innungsstraße 9, 21244 Buchholz,Deutschland
Email/URL	https://www.decobusgroup.de
Hersteller	Guangdong sangu Technology Co., LTD
Adresse	402 Chuangye building,8-28,Shaqi community Central Road,Xingqiao street Bao'an District,Shenzhen
Email/URL	https://aoligd.1688.com/
Partienummer	Power Adapter
Hergestellt in	China
	Decobus Handel GmbH Innungsstraße 9, 21244 Buchholz,Deutschland www.decobusgroup.de
 	Product Name:Power Adapter Model:SG 120200024AE Rated voltage:DC12V Rated frequency:50-60HZ Power:24W



FR
Cet appareil, ses accessoires, cordons et batteries se recyclent

À DÉPOSER EN MAGASIN  OU  À DÉPOSER EN DÉCHÈTERIE

Points de collecte sur www.quefairedemesdechets.fr
Privilégiez la réparation ou le don de votre appareil !