

DE:Installationsanleitung
UK:Installation Instruction
FR:Instructiond'installation
IT:Istruzioni di installazione
ES: Instrucciones deinstalación
NL: Installatie-instructies
SE: Installationsanvisningar
PL:Instrukcjeinstalacji

N877P425229K/N877P425230K/N877P425231K

DE:UnserProdukt wird Ihnen in 2 Paketen geliefert. Die Lieferzeiten dieser 2 Pakete können abweichen, bitte haben Sie etwasGeduld und vielen Dank für IhrVerständnis.

UK:Our product will be delivered to you in 2 packages. The delivery times of these 2 packages may differ, please be patient and thankyou foryour understanding.

FR:Notre produit voussera livré en 2 colis. Les délais de livraison de ces 2 colis peuvent différer, soyez patient et merci pourvotre compréhension.

IT: Il nostro prodotto verrà consegnato in 2 pacchi. I tempi diconsegna di questi 2 pacchi possono variare; vi preghiamo di avere un po' di pazienza e viringraziamo perla vostra comprensione.

ES: Nuestro producto se entregará en 2 paquetes. Los tiempos de entrega de estos 2 paquetes pueden variar; por favor, tenga un poco de paciencia y gracias porsu comprensión.

NL: Ons product wordt in 2 pakketten bij u geleverd. De levertijden van deze 2 pakketten kunnen verschillen, we vragen om uw geduld en bedanken u voor uw begrip.

SE: Vår produkt kommer att levereras till dig i 2 paket. Leveranstiderna för dessa 2 paket kan variera, vi ber om ditt tålamod och tackar för din förståelse.

PL: Nasz produkt zostanie dostarczony w 2 paczkach. Czas dostawy tych 2 paczek może się różnić, prosimy o cierpliwośći dziękujemyza zrozumienie.

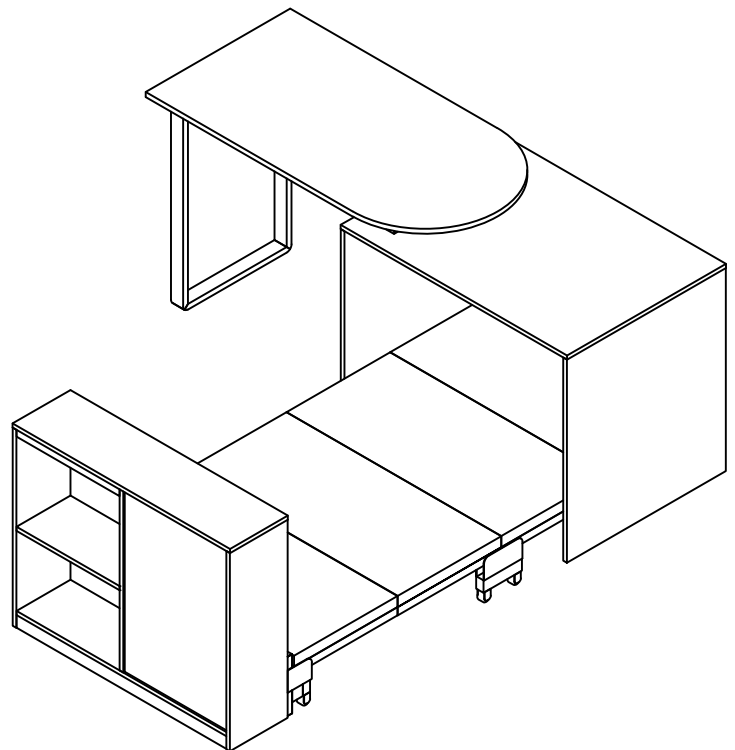

Importeur	DecobusHandelGmbH		
Adresse	InnungsstraBe9,21244Buchholz,Deutschland		
URL	https://www.decobusgroup.de		
Hersteller	HUIDE FURNITURE CO.,LTD		
Adresse	XIWEI INDUSTRY ZONE FOSHAN GUANG DONG CHNIA		
Email/URL	kkuang@huidefurniture.cn		
Partienummer	N877P425229K/N877P425230K/N877P425231K		
Hergestellt in	CHINA		
<table border="1"><tr><td>EC</td><td>REP</td></tr></table>	EC	REP	DecobusHandelGmbH Innungsstraße9,21244Buchholz,Deutschland https://www.decobusgroup.de
EC	REP		

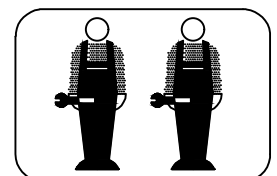

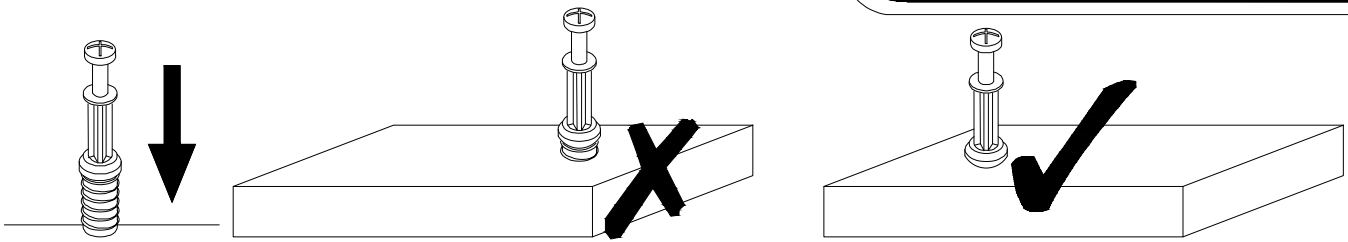

DE_QUICKFIT: Ziehen Sie den Quickfitan, bis die Schultermit der Platte bündig ist. unterspannen.

UK_QUICKFIT: Tighten quickfit until shoulder is flush with panel. Do not overtighten or undertighten.

FR_QUICKFIT: Serrer le quickfit jusqu'à ce que l'épaule soit au même niveau que le panneau. ne pas trop serrer ni trop peu.

IT_SERRATURA: serrare l'attacco rapido fino a quando la spalla non è a filo del pannello. non serrare eccessivamente o insufficientemente.

ES_AJUSTE RÁPIDO: Apriete el ajuste rápido hasta que el hombro quede a ras con el panel. No apriete demasiado ni demasiado poco.

NL_QUICKFIT: Draai de quickfit aan tot de schouder gelijk ligt met het paneel. niet te strak draaien.

SE_QUICKFIT: Dra åtsnabbfästet tills axeln äri jämnhöjd med panelen. Dra inte åt för hårt eller underspänna.

PL_QUICKFIT: Dokręćciś szybko złączkę do momentu że równaniaramienia z panelem. nie dokręcać zbyt mocno.

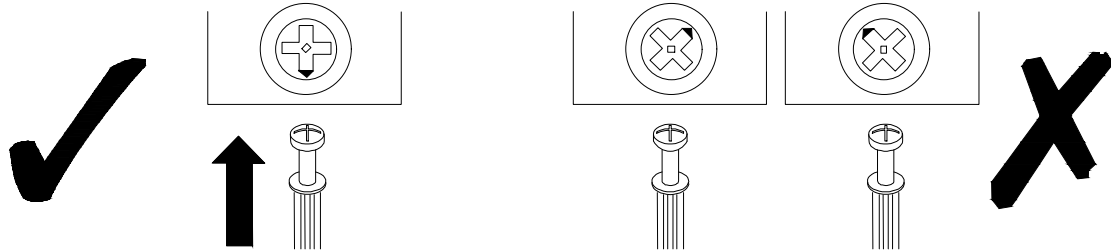

DE_CAM LÄCK: Achten Sie bei der Montage des Nockenschlosses darauf, dass die Ausgangsposition korrekt ist, bevor Sie den Verbindungsschnellverschluss einstecken.

UK_CAM LÄCK: When fitting camlock, ensure starting position is correct before you insert connecting quickfit.

FR_CAM LÄCK: Lors de la mise en place du verrou à came, s'assurer que la position de départ est correcte avant d'insérer le boulon rapide de connexion.

IT_Quando si monta il blocco a camme, assicurarsi che la posizione di partenza sia corretta prima di inserire l'attacco rapido.

ES_CAM LÄCK: Al instalar el cierre de leva, asegurarse de que la posición inicial es correcta antes de insertar el eje rápido de conexión.

NL_CAM LÄCK: Zorg er bij het monteren van de nokvergrendeling voor dat de uitgangspositie correct is voordat je de verbindingssnelkoppeling plaatst.

SE_CAM LÄCK: Vid montering av cam lock, se till att utgångsläget är korrekt innan du sätter i snabbfästet.

PL_Blokada krzywkowa: Podczas montażu blokady krzywkowej należy upewnić się, że pozycja wyjściowa jest **prawidłowa przed włożeniem szybkozłączki.**

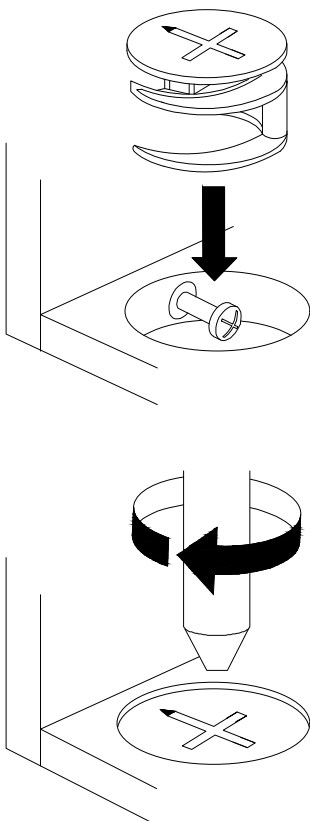

DE_Der Quickfit-Kopf sollte auf dem Nockenschloss zentriert sein, wenn die beiden Platten zusammengefügt sind.

UK_When two panels are connected together, the quick mount head must be centered on the cam lock.

FR_Lors de la connexion de deux panneaux, la tête de montage rapide doit se trouver au centre du bloc de came.

IT_Quando si uniscono due pannelli, la testa di montaggio rapido deve essere centrata sul blocco a camme.

ES_Cuando se conectan dos paneles, el cabezal de montaje rápido debe estar en el centro del bloque de levas.

NL_Bij het verbinden van twee panelen moet de snelmontagekop in het midden van het nokkenblok zitten.

SE_Vid sammankoppling av två paneler måste snabbmonteringshuvudet vara i mitten av kamblocket.

PL_Gdy dwa panele są ze sobą połączone, głowica szybkiego montażu musi być wyśrodkowana na blokadzie krzywkowej.

DE_Drehen Sie das Nockenschloss im Uhrzeigersinn, um es zu spannen.

UK_Turn camlock clockwise to tighten.

FR_Tourner le camlock dans le sens des aiguilles d'une montre pour le serrer.

IT_Ruotare il blocco a camme in senso orario per serrare.

ES_Girela la leva en el sentido de las agujas del reloj para apretarla.

NL_Draai de nokkenslot rechtsom om vast te draaien.

SE_Vrid kamlåset medurs för att tätta.

PL_Obróć blokadę zgodnie z ruchem wskazówek zegara, aby ją dokręcić.

DE:VordemEinbaudieSchraubenindie Löcher steckenundfestziehen, aber nicht bis 100%, 70%bis 80%anziehenreicht aus. Schließlich, nachdem alle Schrauben installiert sind, ziehenSiealleSchrauben auf 100%.WennSieaufdieseProblemestoßen,wiez.B. Fehlausrichtungder LöcheroderUnfähigkeit,bestimmteTeilezuinstallieren, überprüfen Siebitte,obdieSchraubenkorrektverwendetwerdenundpassenSiedieDichtigkeitder Schrauben an.

UK:Beforeinstallation, insert the screws into theholes and tighten them, but do not tighten them to100%, 70% to80%is sufficient. Finally, afterall screws are installed, tighten all screws to 100%.If youencounter theseissues, suchas if theholes cannot be aligned or some parts cannot beinstalled, please check if the screws areused correctly and adjust the tightness of the screws.

FR:Insérerla vis dans le trouavant la findel'assemblage, serrerla vis, mais ne pas serrer à100%, 70%~80%est correct. Enfin, une fois que toutesles vis sont bien serrées, toutes les vis sont serrées à100%.Si vous rencontrez ces problèmes, par exemple siles trous ne sont pas alignés ou si certaines pièces nepeuvent pas êtremontées, vérifiez que les vis sont utilisées correctement et Ajustez leur serrage.

IT:Primadell'installazione,inserirelevitineiforiestringerle,manonal100%, èsufficiente stringerleal70%-80%. Infine, dopoaverinstallato tuttele viti, stringere tutte le viti al 100%. Seriscontri problemicomedisallineamentideiforioidifficoltànell'installarealcuni componenti, verifica chele viti sianoutilizzate correttamente e regola la tensione delle viti.

ES:Antesdelainstalación,coloque lostornillosen los agujerosy apriételos, peronoal 100%;apretaral70%-80%essuficiente.Finalmente, despuésdehaberinstaladotodos lostornillos, aprietetodoslostornillosal100%.Sise encuentracon problemascomo desalineacióndelos agujerosodificultadparainstalarciertaspiezas,verifiqueque los tornillos seesténutilizando correctamente y ajuste la tensión de los tornillos.

NL:Voordat ubegint met deinstallatie, plaatst ude schroeven in de gaten en draait u ze aan, maardraai zeniet volledigaan; 70% tot 80%is voldoende. Draai uiteindelijk, nadat alle schroeven zijngeplaatst, alle schroeven volledig aan. Als u problemen ondervindt, zoals niet uitgelijndegatenof onderdelendieniet kunnen worden geïnstalleerd, controleer danof de schroeven correct zijngebruikt enpas de spanning van de schroeven aan.

SE:Innaninstallation, sätt i skruvarna i hålenoch dra åt dem, men dra inte åt dem helt; 70% till80% är tillräckligt. Slutligen, näralla skruvar är installerade, dra åt alla skruvar helt. Om du stöter påproblem, somatt håleninte kanjusteras eller vissa delarinte kan installeras, kontrolleraom skruvarnaanvänds korrekt ochjustera skruvarnas åtdragning.

PL:Przedinstalacją wstaw śruby w otwory idokręćje, ale nie dokręcajich na 100%; 70% do80% wystarczy. Na koniec, po zainstalowaniu wszystkich śrub, dokręćwszystkie śruby do100%. Jeślinapotkasz problemy, takiejak niedopasowane otwory lub części, które nie mogąbyć zainstalowane, sprawdź, czy śruby są używaneprawidłowo i dostosujich dokręcenie.

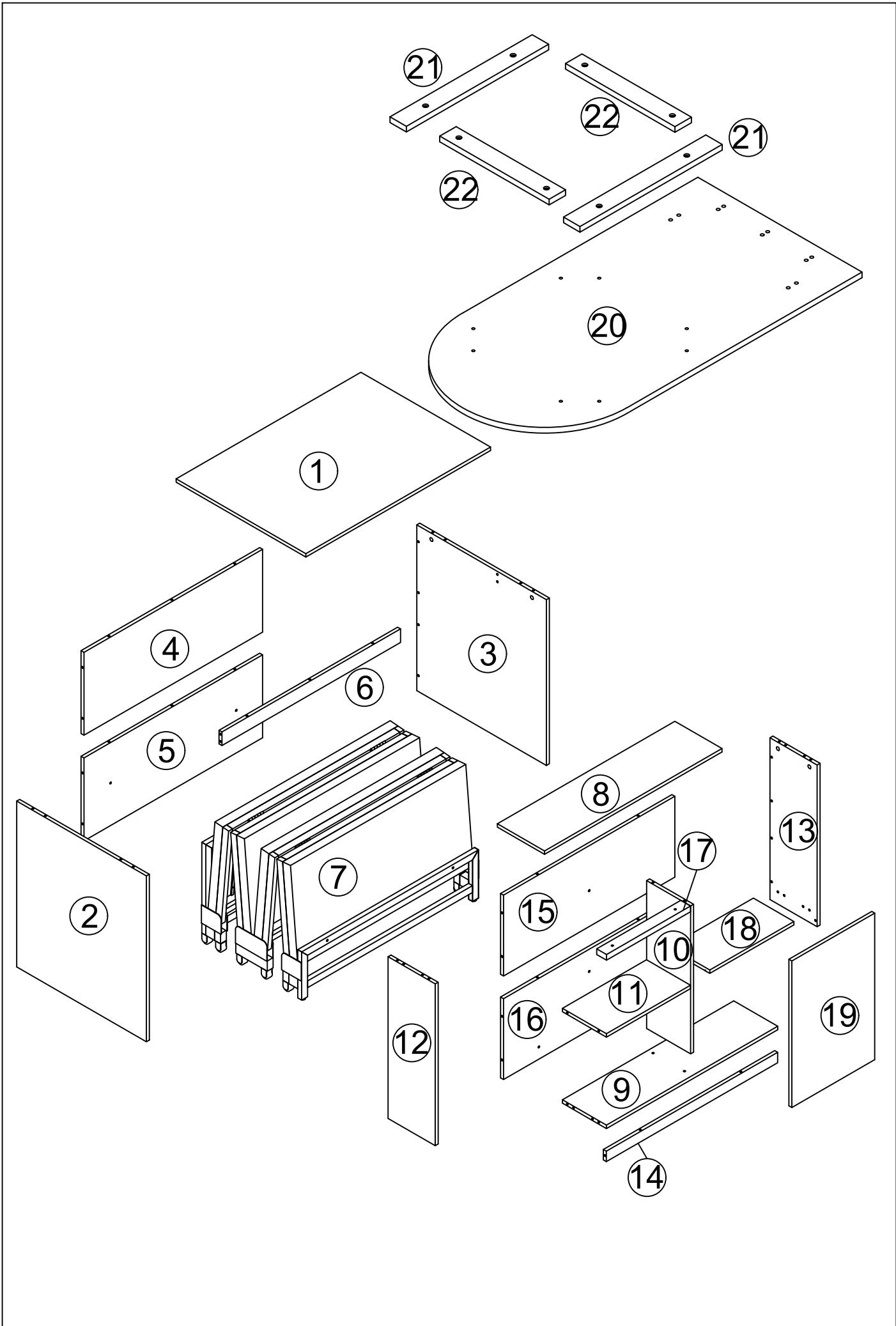

N877P425229K

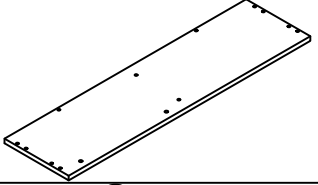
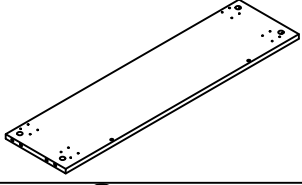
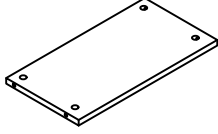
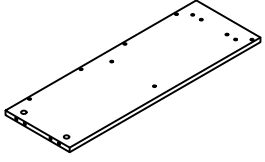
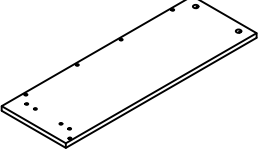
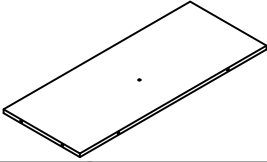
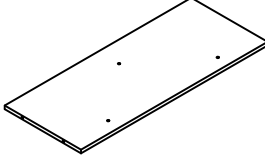
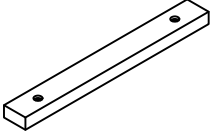
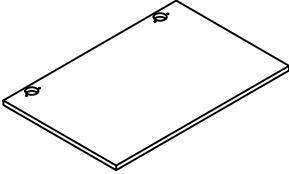
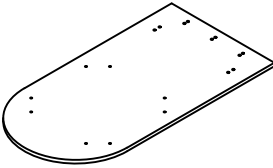
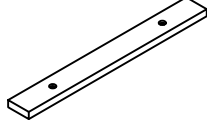
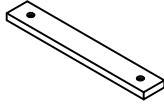
			
⑧×1pcs	⑨×1pcs	⑪×1pcs	⑫×1pcs
			
⑬×1pcs	⑮×1pcs	⑯×1pcs	⑰×1pcs
			
⑲×1pcs	⑳×1pcs	㉑×2pcs	㉒×2pcs

N877P425230K

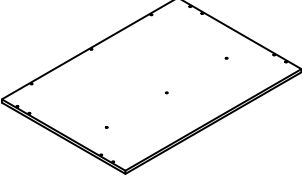
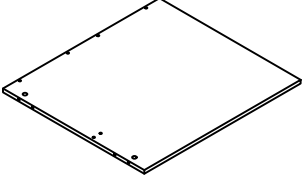
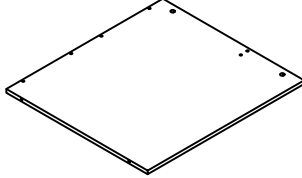
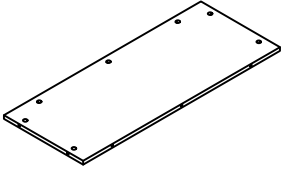
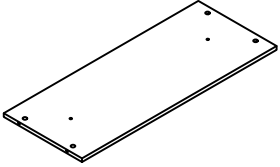
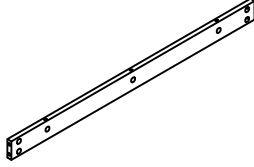
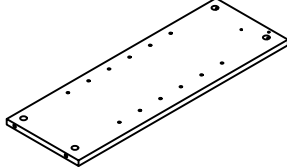
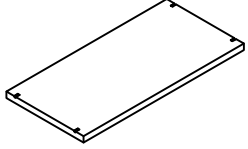
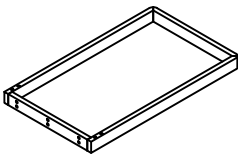



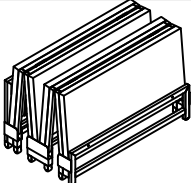
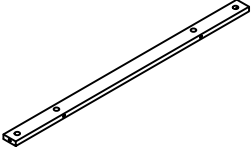





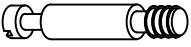

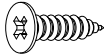
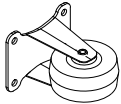
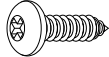
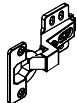

			
①×1pcs	②×1pcs	③×1pcs	④×1pc
			
⑤×1pcs	⑥×1pcs	⑩×1pcs	⑱×1pcs
			
㊸×1pcs			

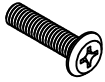
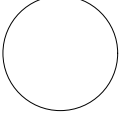
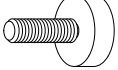
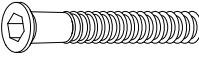
N877P425231K

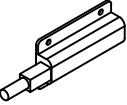
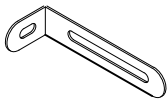
			
⑦×1pcs	⑭×1pcs		

HardwareList
Hardwareliste

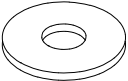
N877P425230K

 $\phi 6.5 \times 28 \text{mm}$ (A) × 52 pcs	 $\phi 15 \times 10 \text{mm}$ (B) × 52 pcs	 $\phi 8 \times 30 \text{mm}$ (C) × 32 pcs	 $\phi 3.5 \times 14 \text{mm}$ (D) × 16 pcs	 (E) × 4 pcs
 $\phi 5 \times 14 \text{mm}$ (F) × 22 pcs	 (H) × 2 pcs	 (I) × 2 pcs	 $\phi 6 \times 30 \text{mm}$ (J) × 14 pcs	 $\phi 6 \times 25 \text{mm}$ (K) × 8 pcs
 $\phi 8 \times 30 \text{mm}$ (L) × 3 pcs	 (M) × 9 pcs	 (N) × 4 pcs	 $\phi 6 \times 38 \text{mm}$ (O) × 4 pcs	 6mm (P) × 4 pcs
 (Q) × 1 pcs	 (R) × 2 pcs	 (S) × 2 pcs	 $\phi 5 \times 40 \text{mm}$ (U) × 2 pcs	 (V) × 2 pcs
 $\phi 6 \times 20 \text{mm}$ (W) × 4 pcs	 (X) × 2 pcs	 (Y) × 1 pcs		

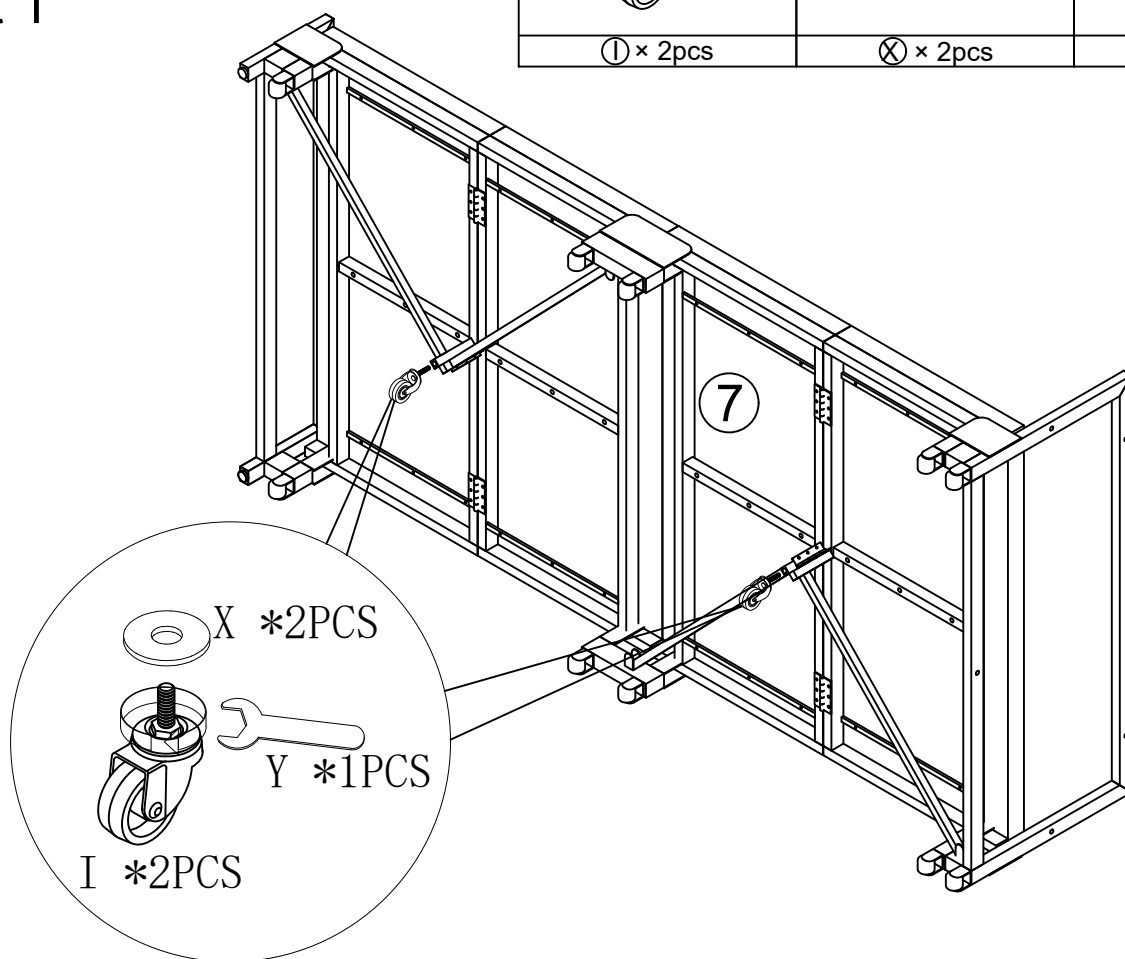
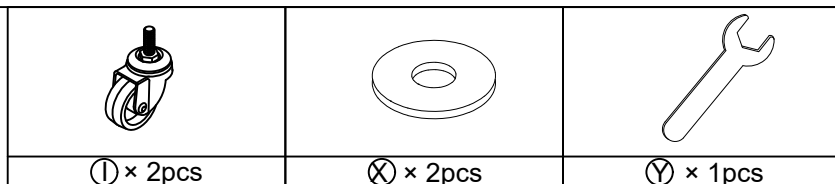

Step 1
Schritt 1

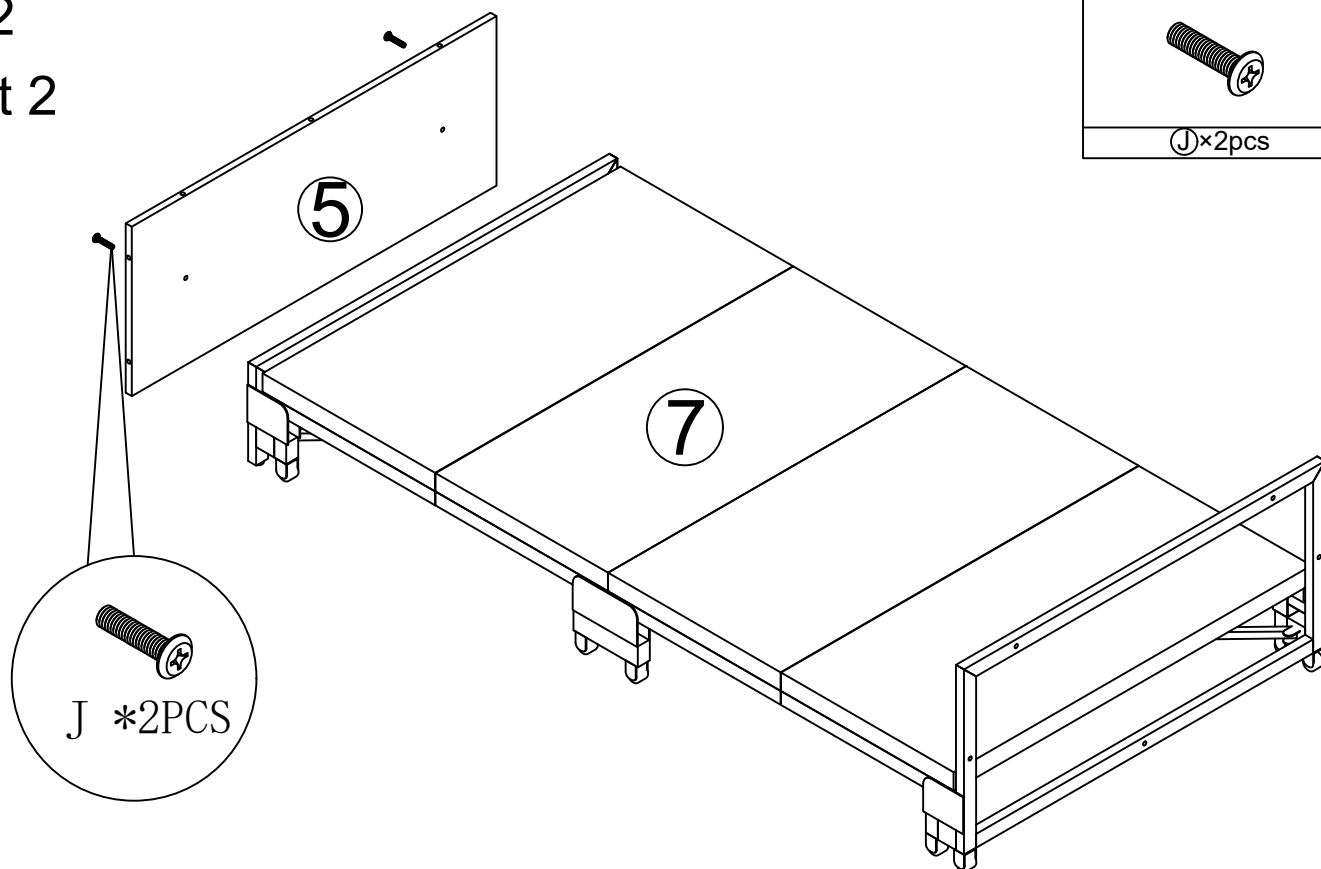
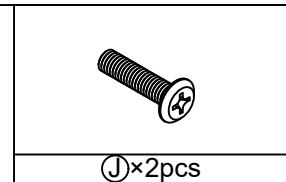

Step 2
Schritt 2

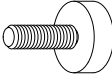
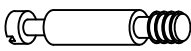

Step 3
Schritt 3

		
$\text{N} \times 4\text{pcs}$	$\text{A} \times 12\text{pcs}$ $\phi 6.5 \times 28\text{mm}$	$\text{C} \times 4\text{pcs}$ $\phi 8 \times 30\text{mm}$

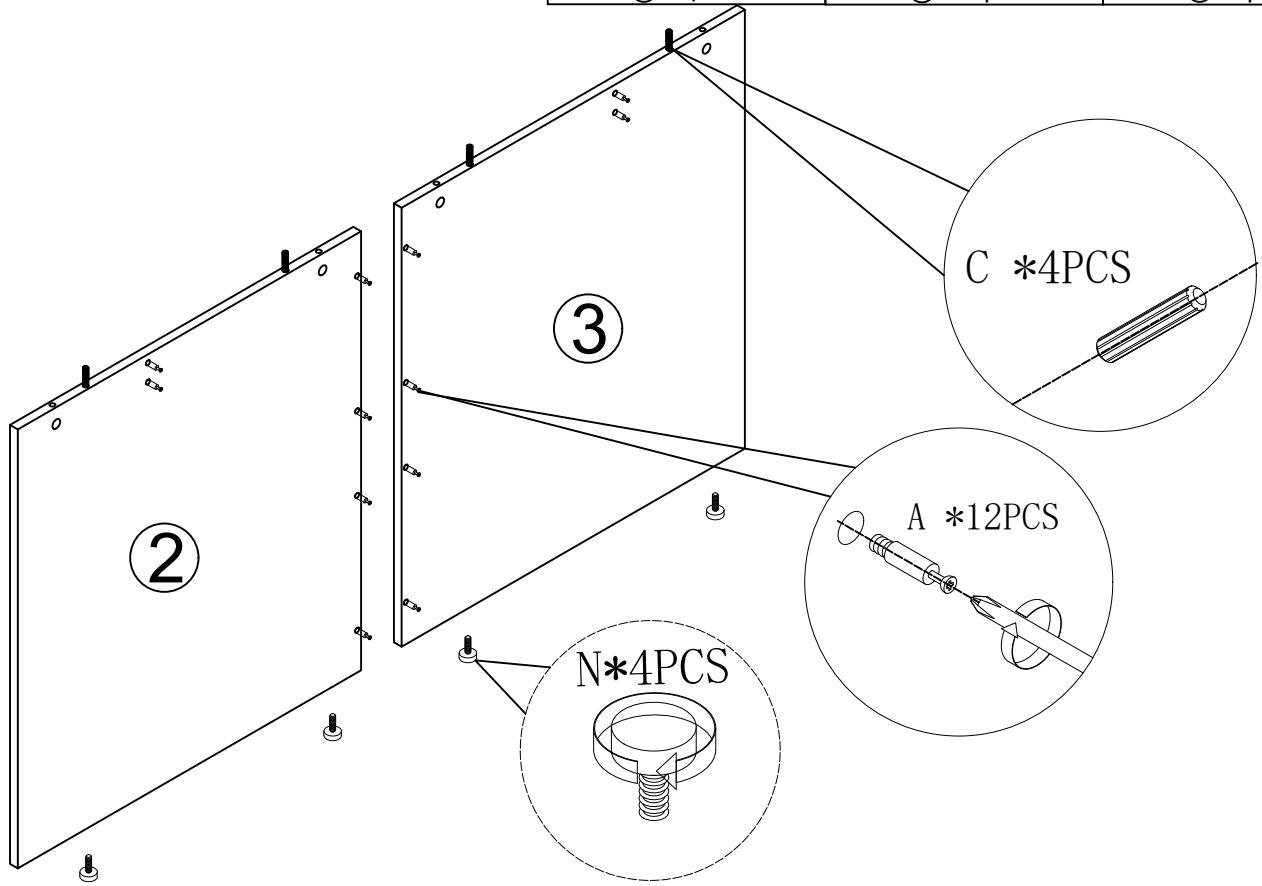

Step 4
Schritt 4

$\phi 8 \times 30\text{mm}$
$\text{C} \times 3\text{pcs}$

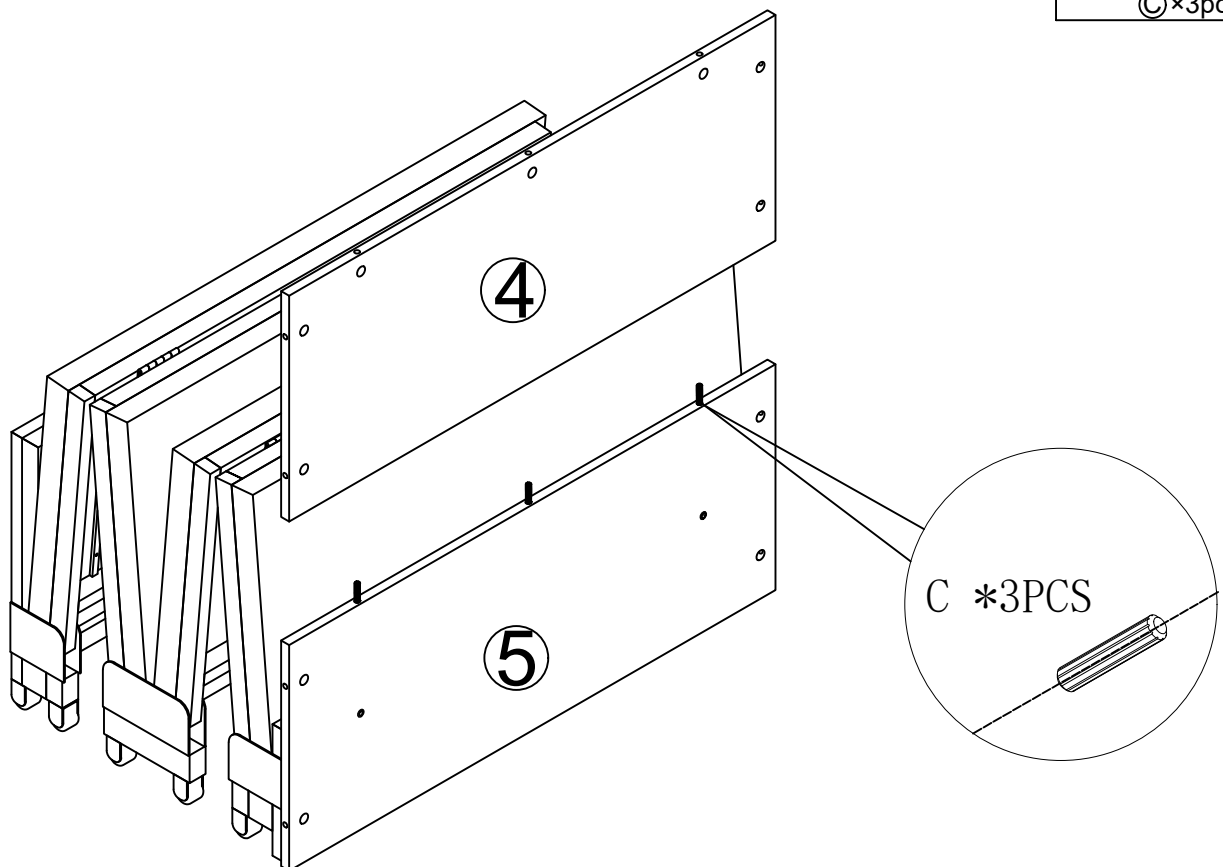

Step 5
Schritt 5



φ15*10mm

Ⓑ × 12pcs

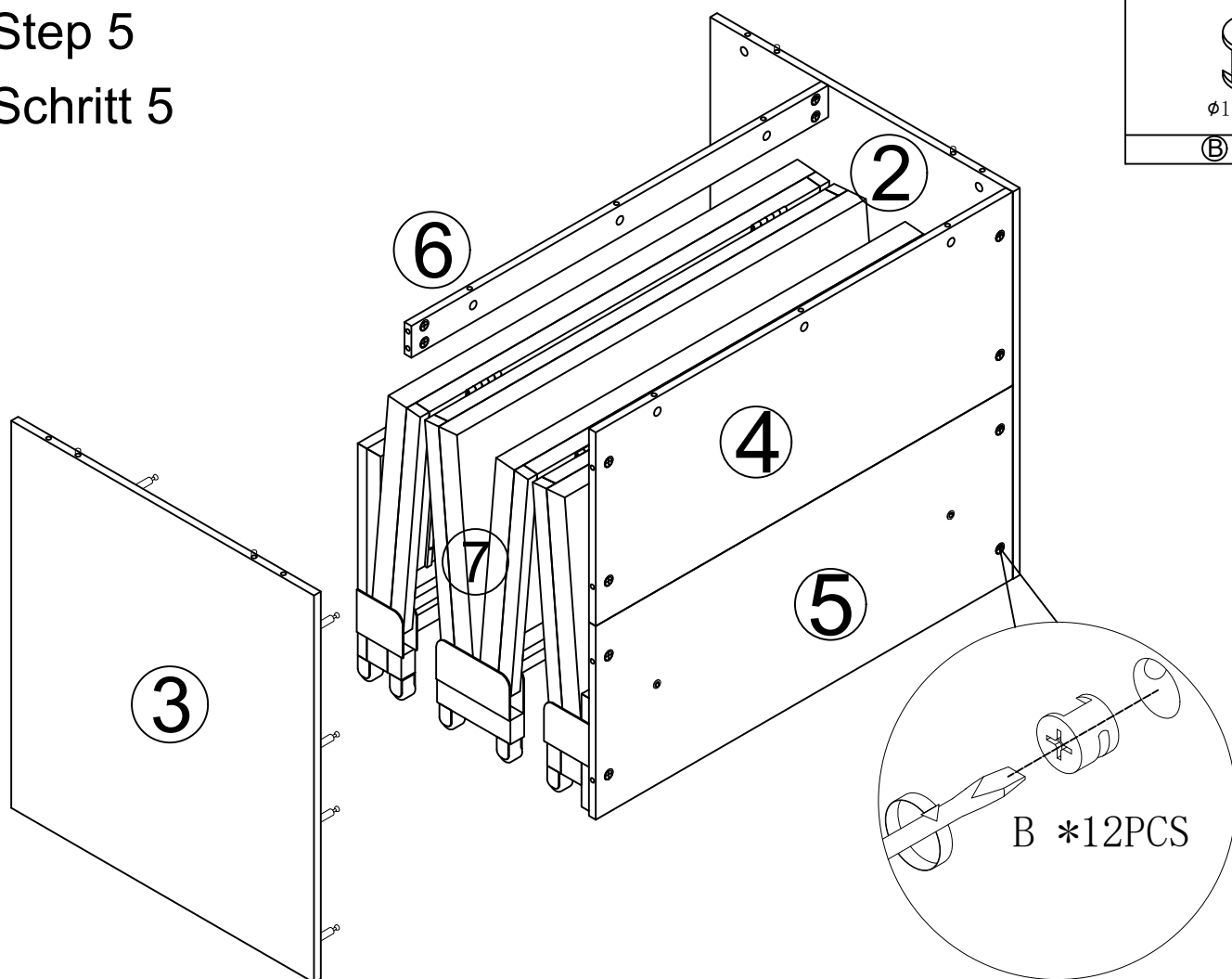

Step 6
Schritt 6

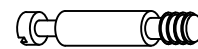

φ6.5*28mm

Ⓐ × 10pcs

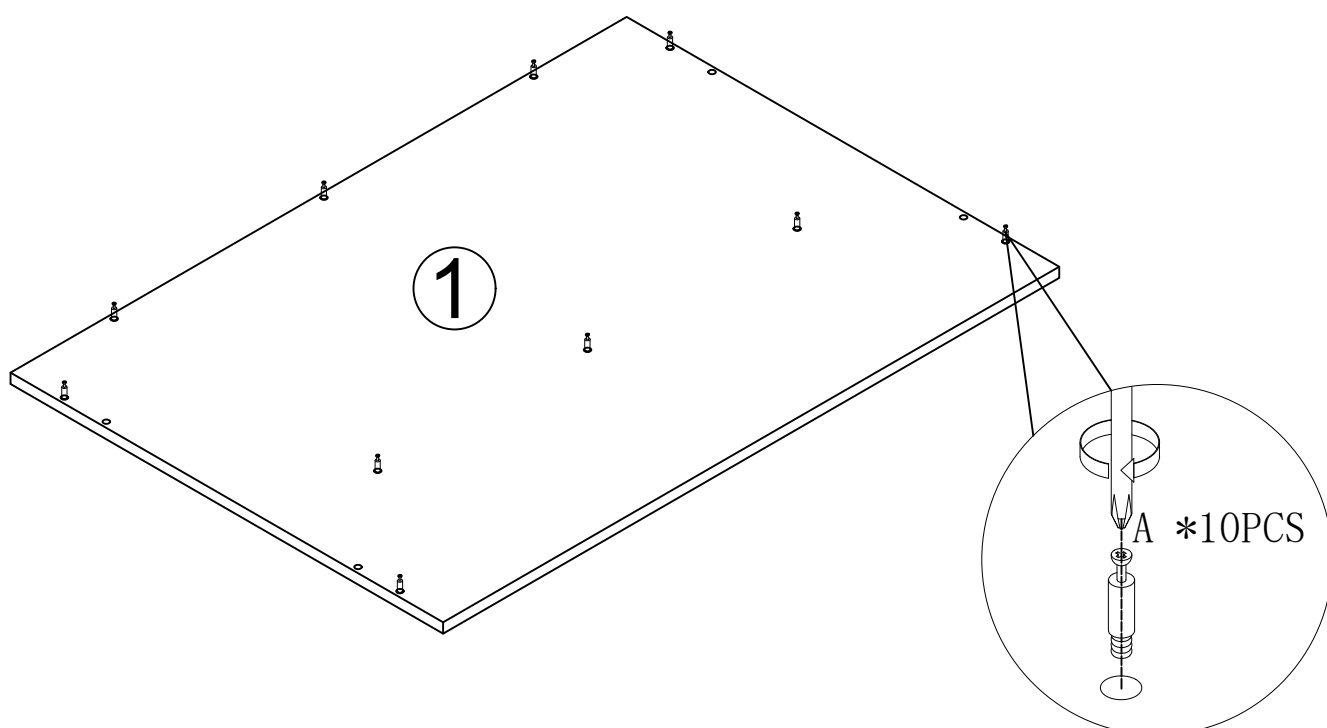

Step 7
Schritt 7

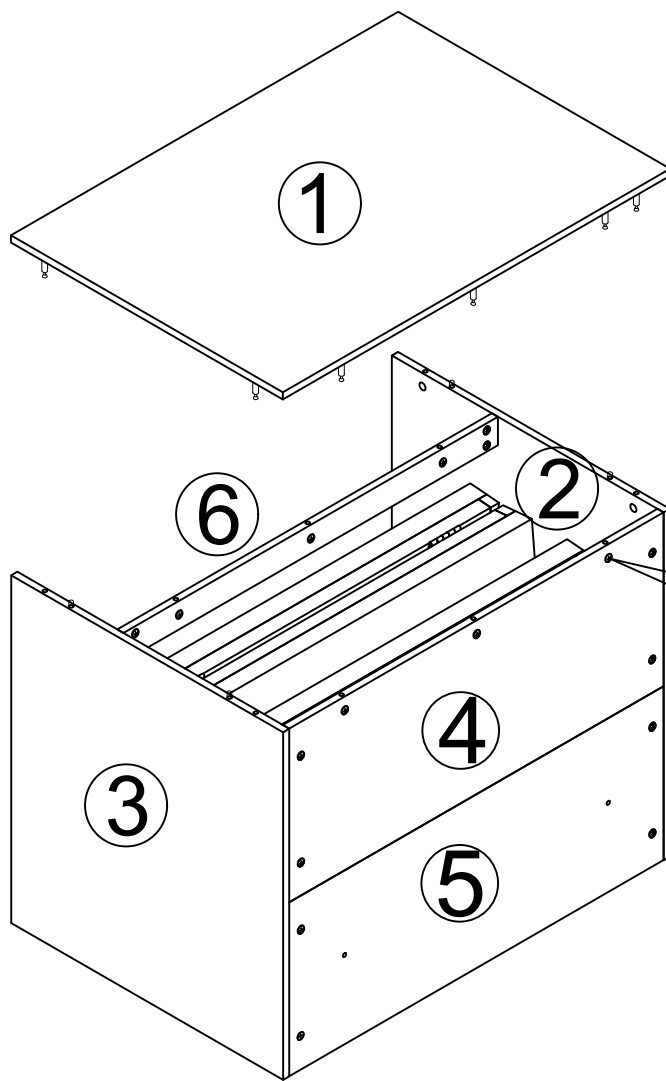

φ15*10mm

Ⓑ × 10 pcs

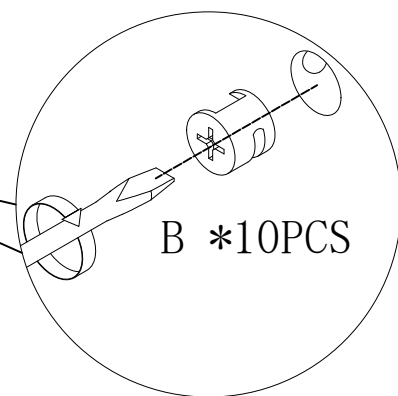

B *10PCS

Step 8
Schritt 8

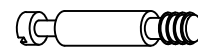
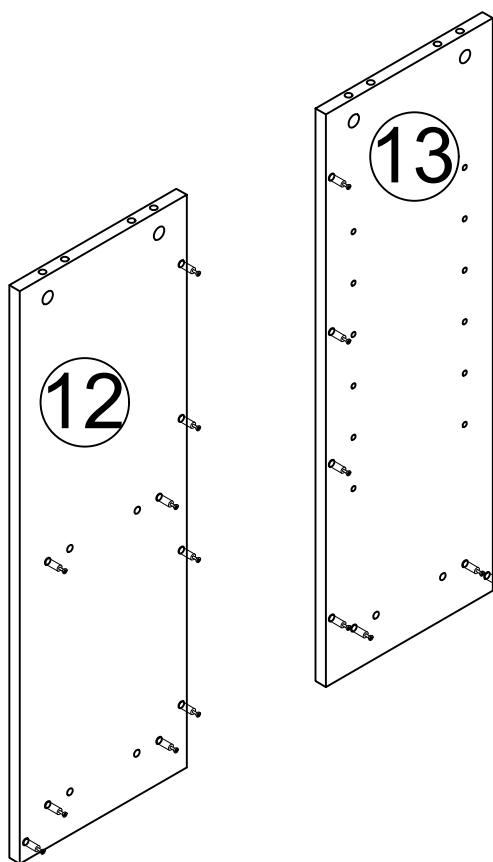

φ6.5*28mm

Ⓐ × 16 pcs

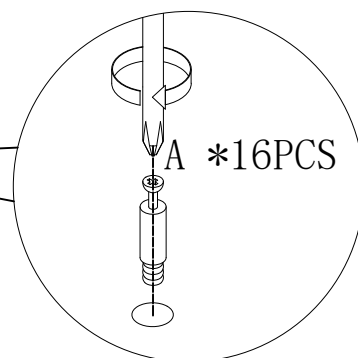

A *16PCS

Step 9
Schritt 9

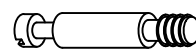

Ø6.5*28mm

Ⓐ *2pcs



Ø15*10mm

Ⓑ *2pcs

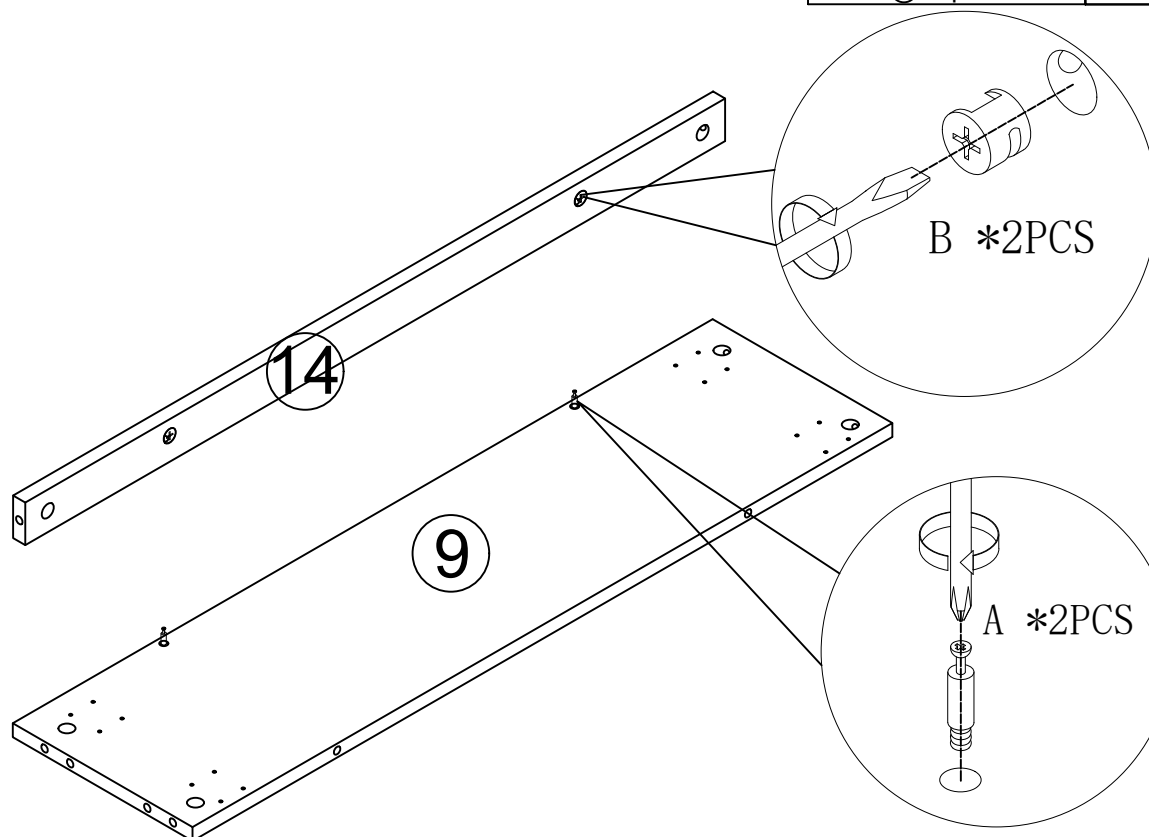

Step 10
Schritt 10

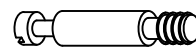

Ø6.5*28mm

Ⓐ *2pcs



Ø15*10mm

Ⓑ *2pcs

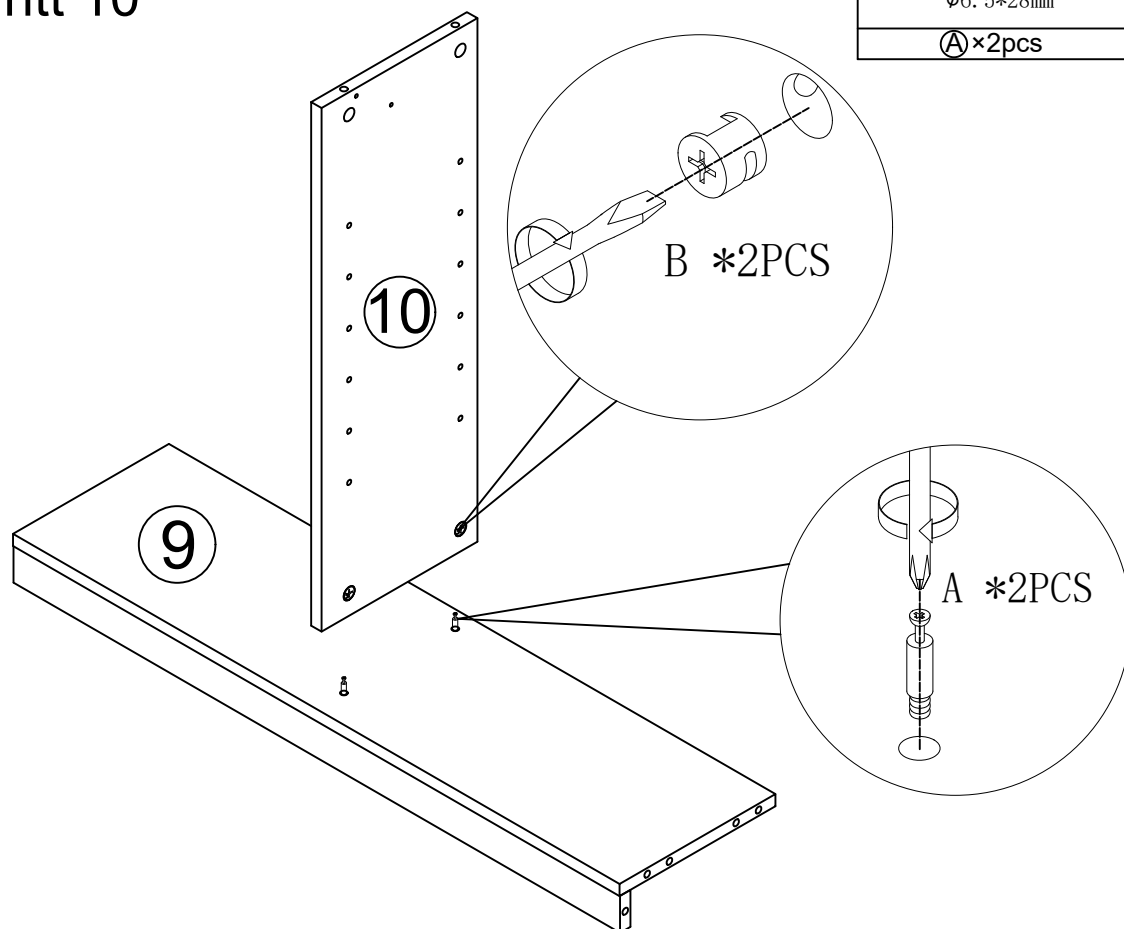

Step 11
Schritt 11



Ø8*30mm

© *2pcs

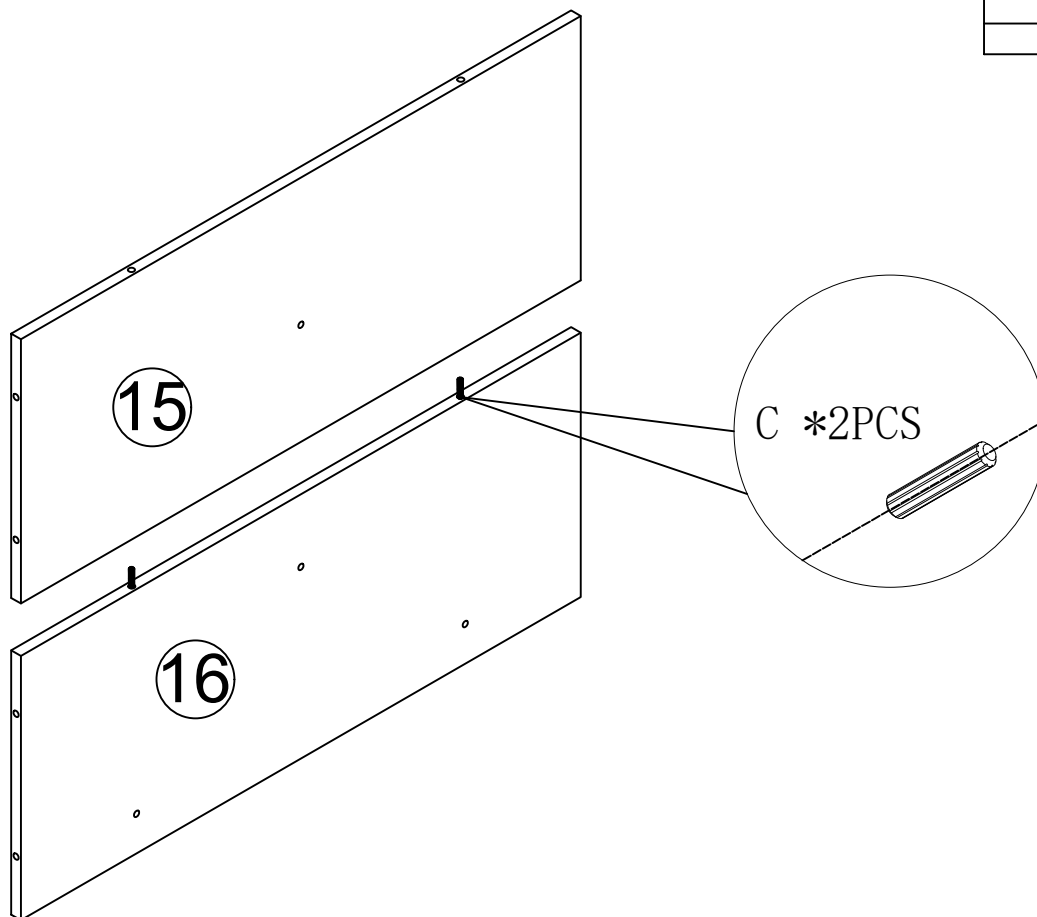

Step 12
Schritt 12



Ø15*10mm

Ⓑ *7pcs



Ø8*30mm

© *2pcs

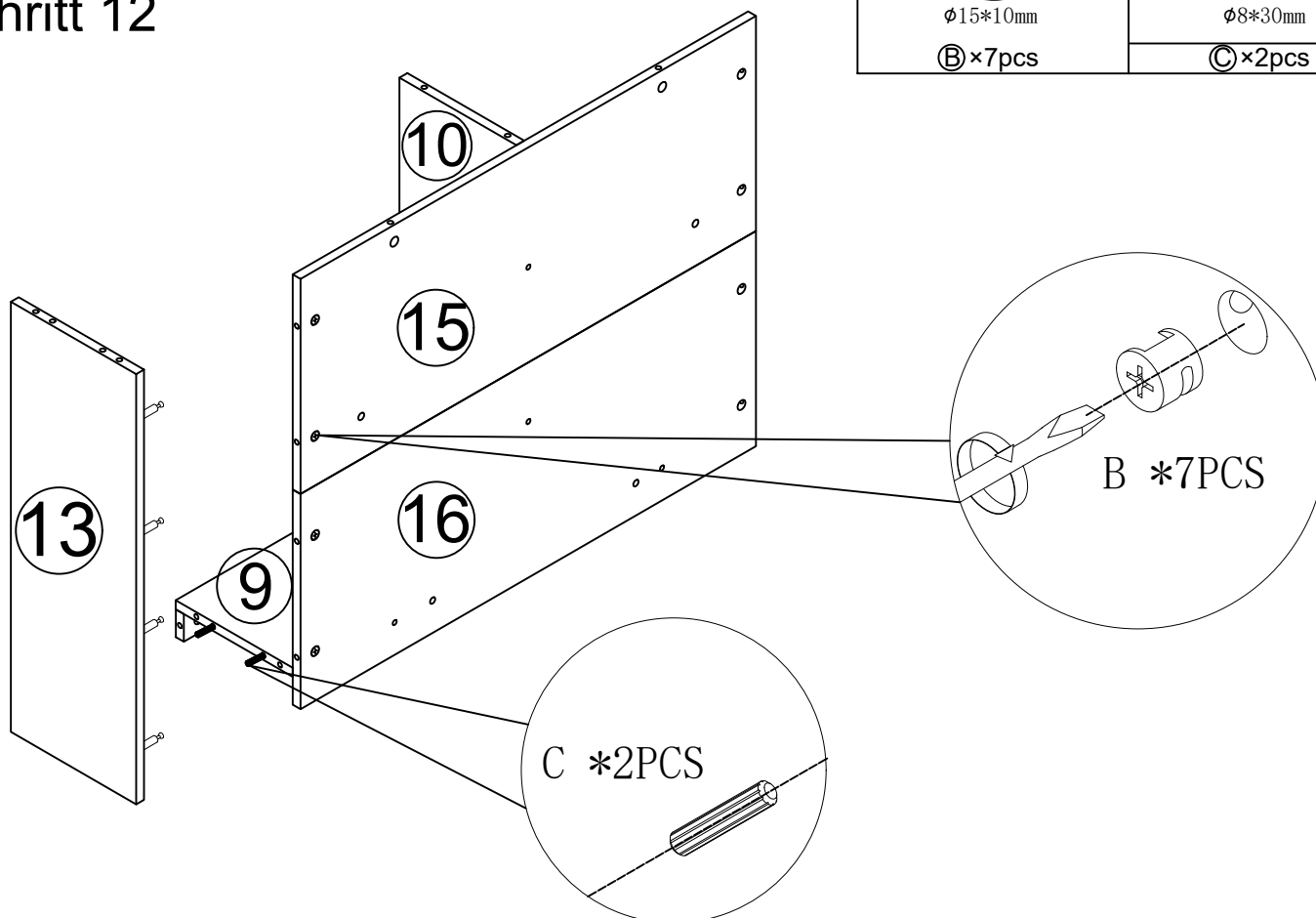

Step 13

Schritt 13

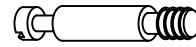

Ø6.5*28mm

(A) × 2 pcs



Ø15*10mm

(B) × 2 pcs

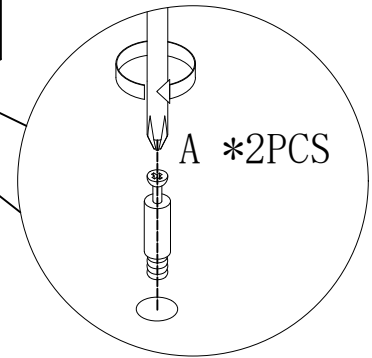
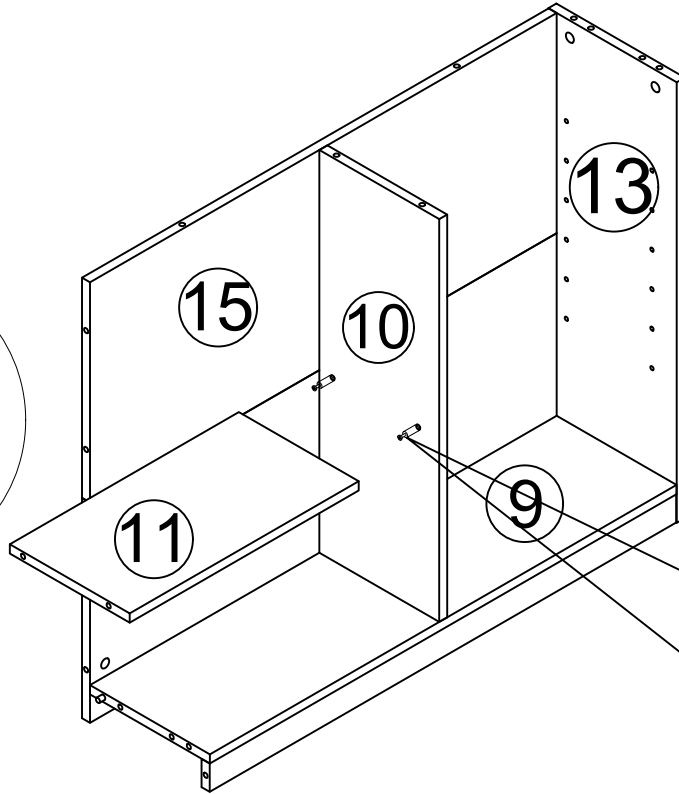
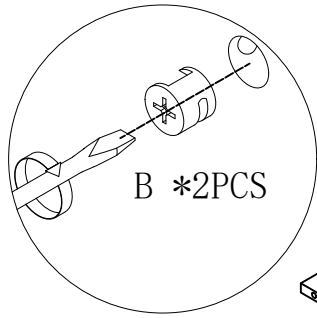

Step 14

Schritt 14



Ø15*10mm

(B) × 9 pcs



Ø8*30mm

(C) × 4 pcs



6mm

(P) × 4 pcs

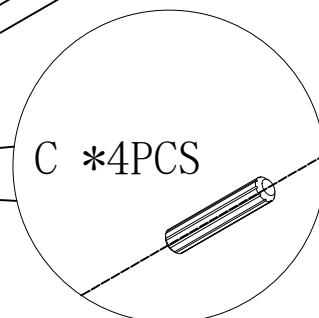
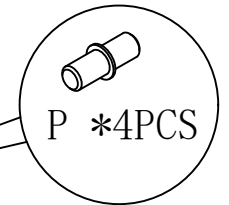
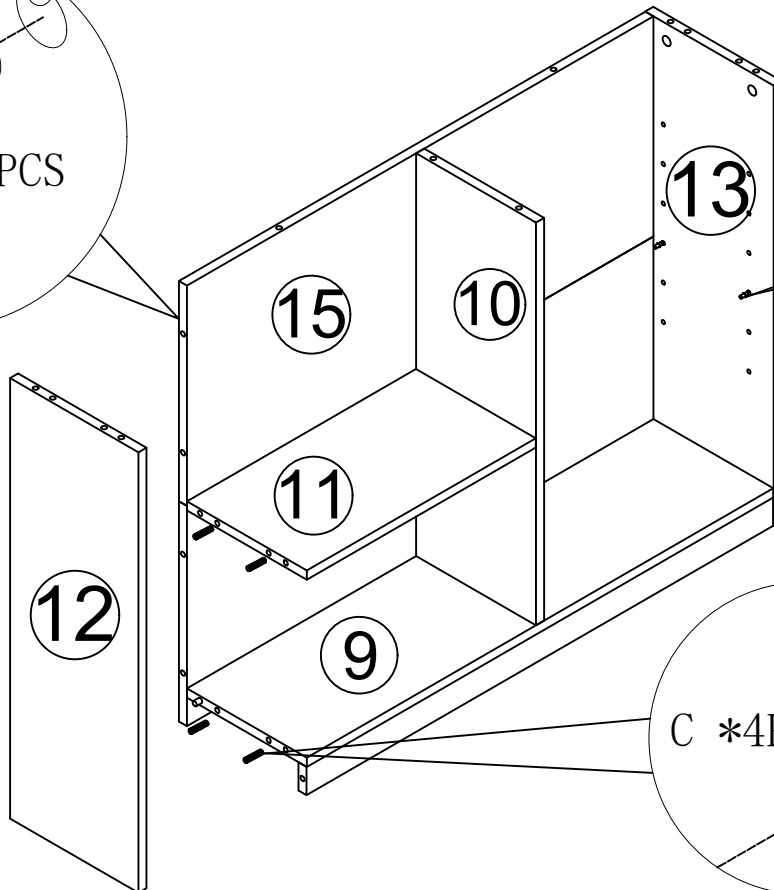
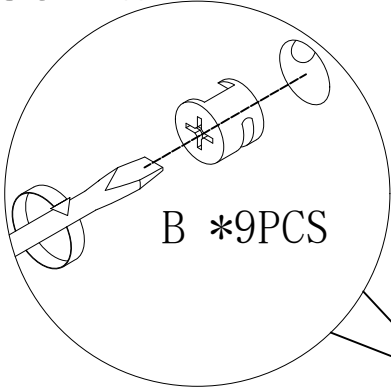

Step 15

Schritt 15

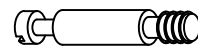

∅6.5*28mm

Ⓐ *8pcs

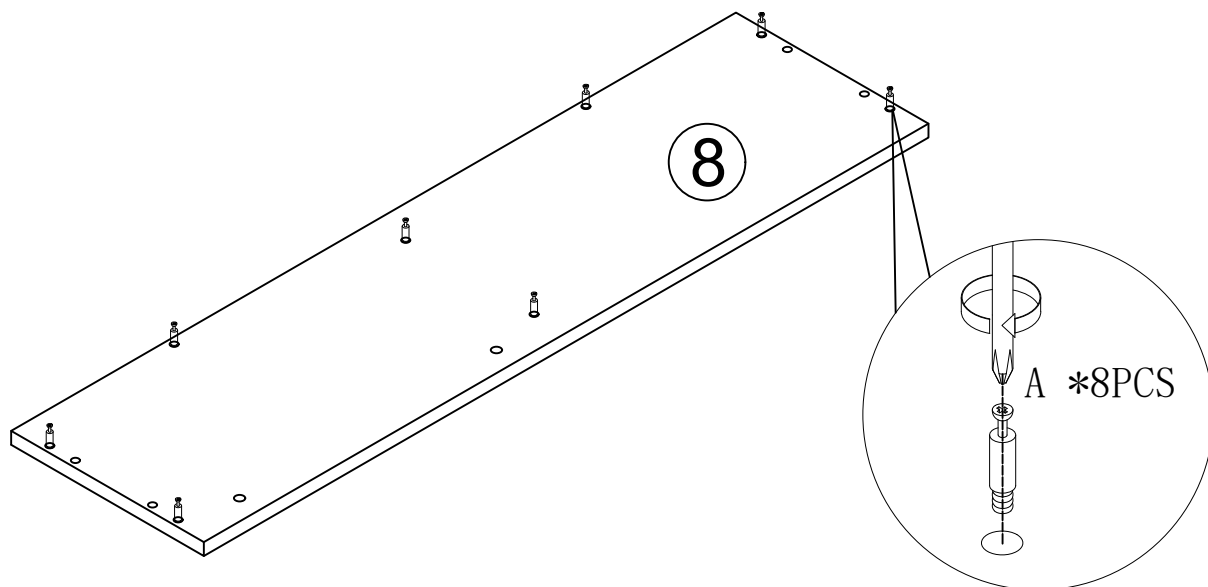

Step 16

Schritt 16



∅15*10mm

Ⓑ *8pcs



∅8*30mm

Ⓒ *4pcs

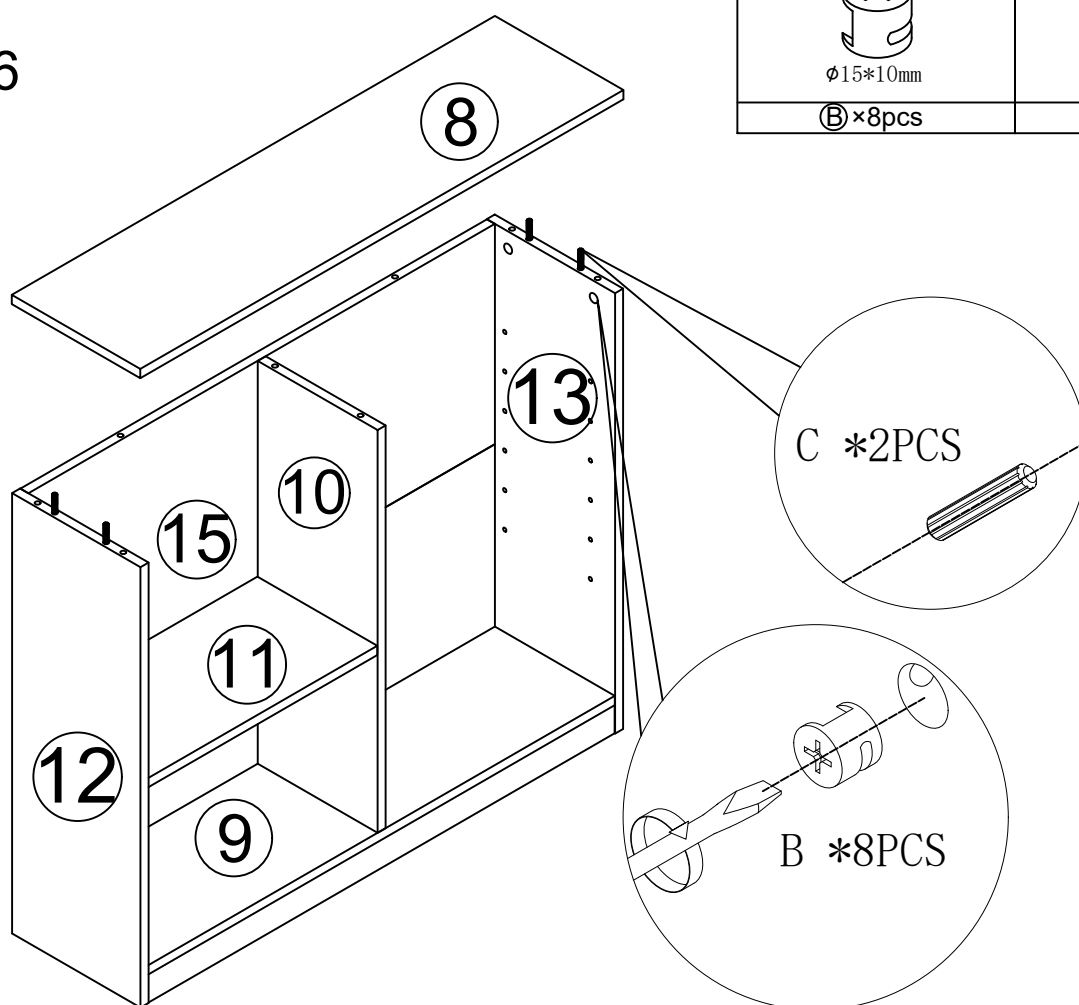

Step 17
Schritt 17

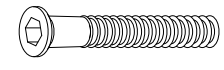

Ø6*38mm

⊙×4pcs

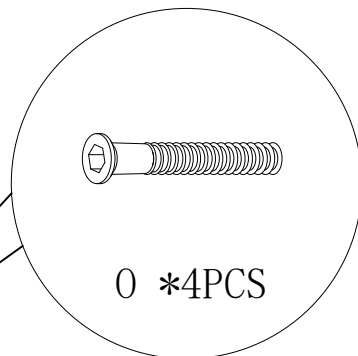
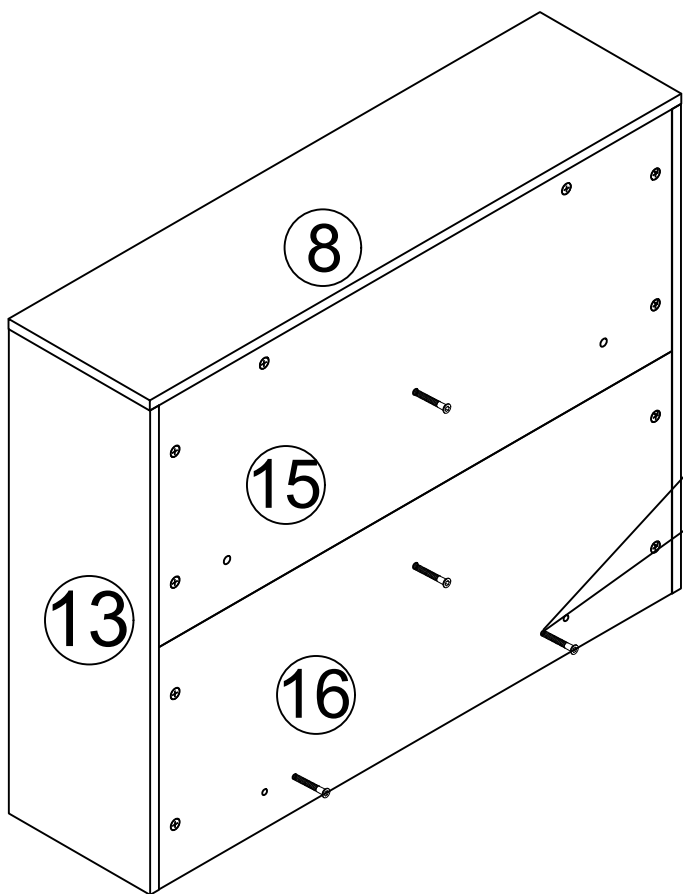

Step 18
Schritt 18

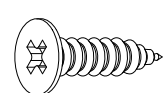

⊙×4pcs

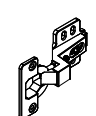

⊕×2pcs

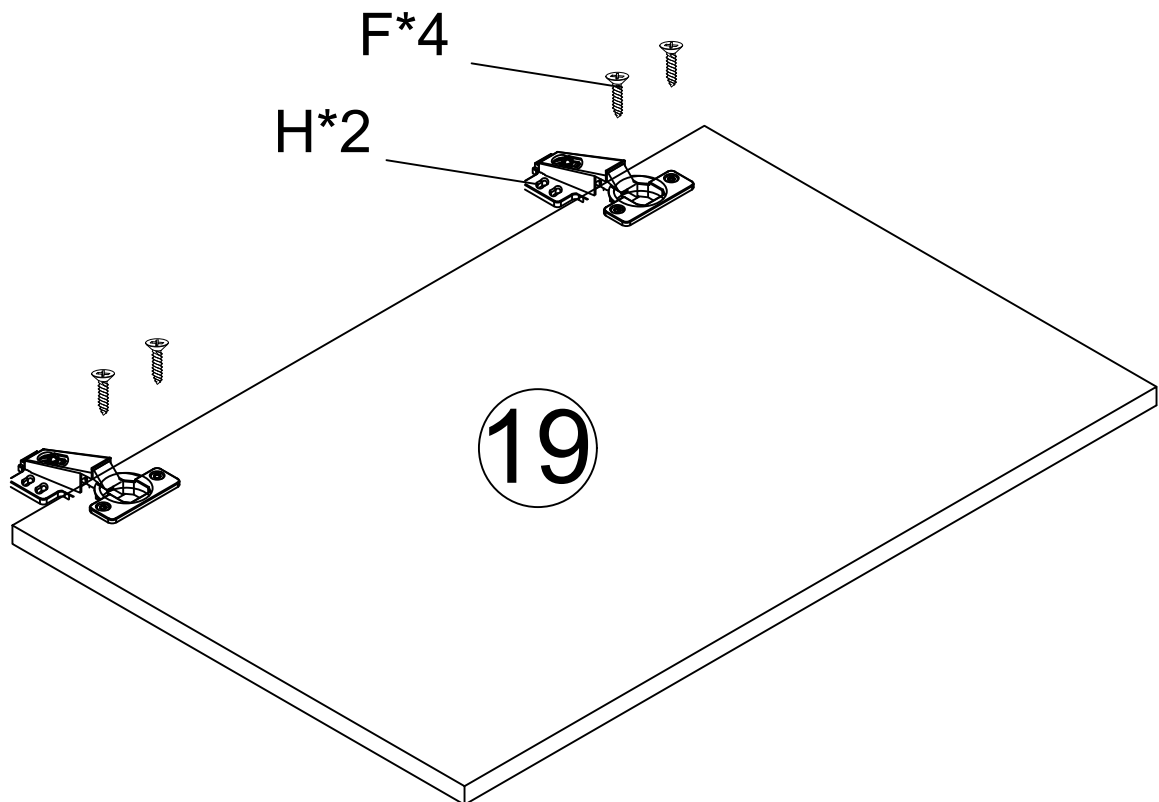

Step 19
Schritt 19



Ø6*30mm

J *2pcs

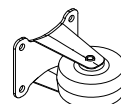

E *4pcs

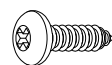

Ø5*14mm

F *16pcs

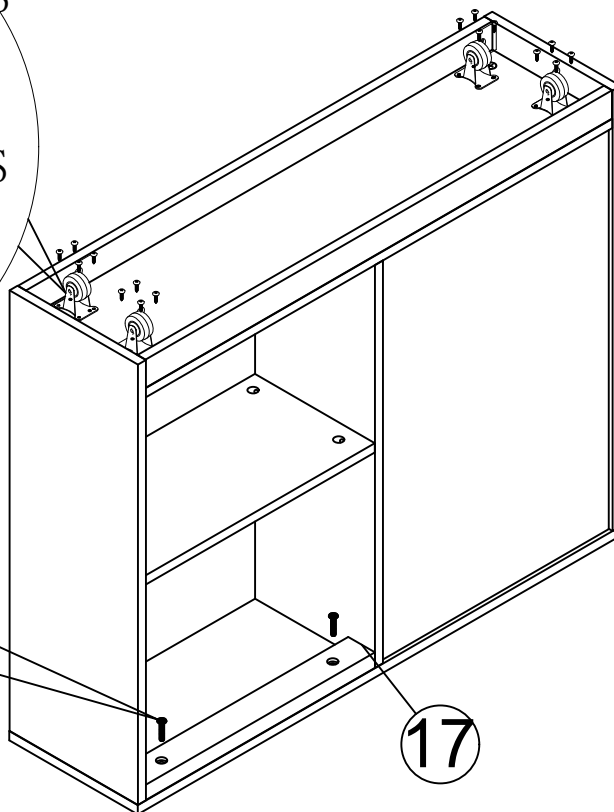
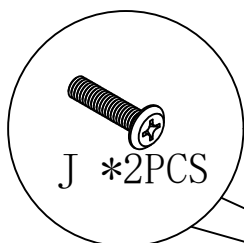
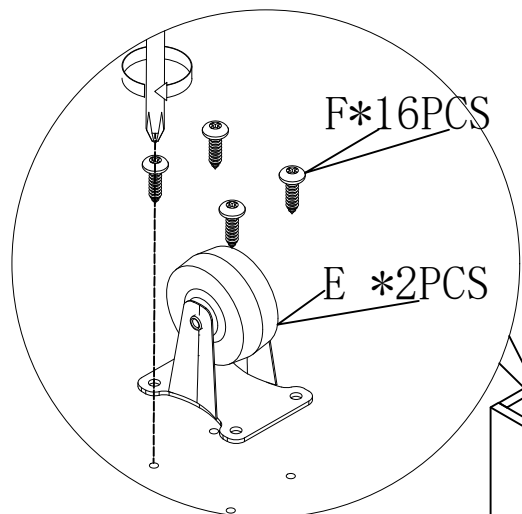

Step 20
Schritt 20

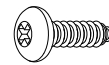

Ø5*14mm

F *4pcs

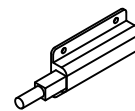

Q *1pcs

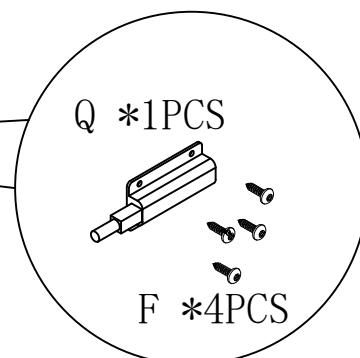
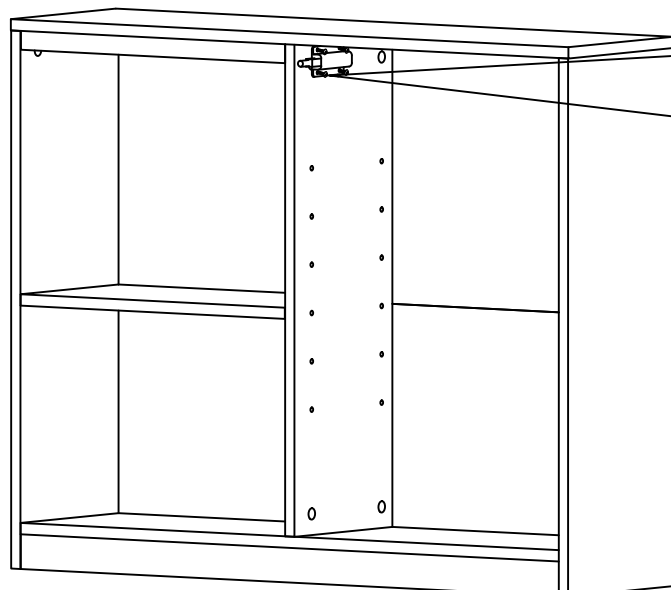

Step 21
Schritt 21

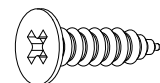

⌀×8pcs

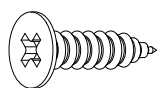

F *8PCS

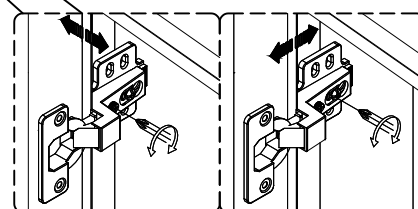
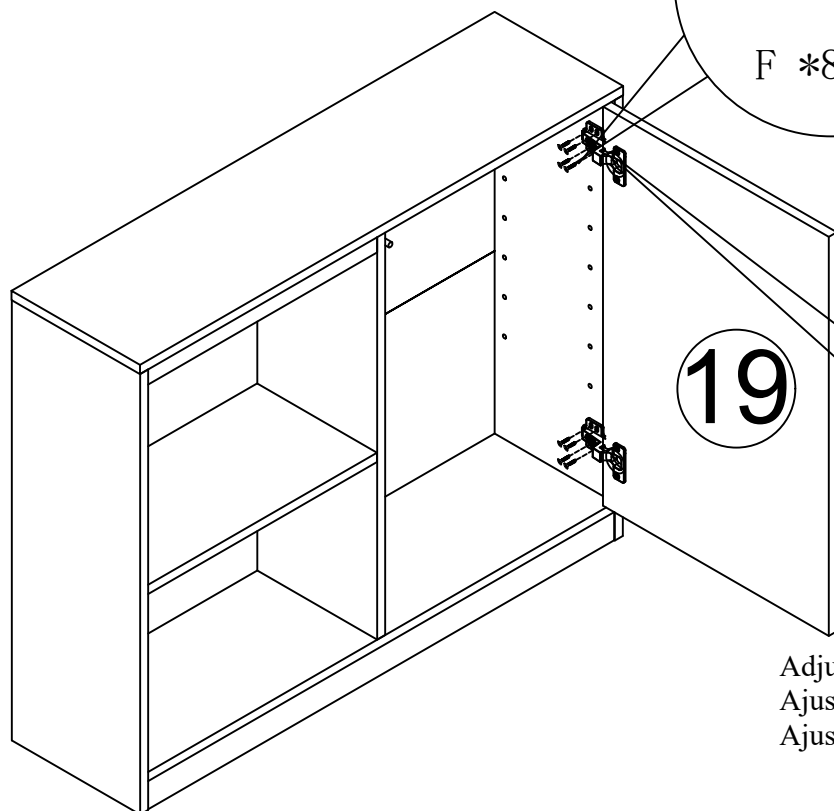

Adjust this screw to balance the crack of the door.
Ajuste este tornillo para equilibrar la grieta de la puerta.
Ajustez cette vis pour équilibrer la fissure de la porte.

Step 22
Schritt 22

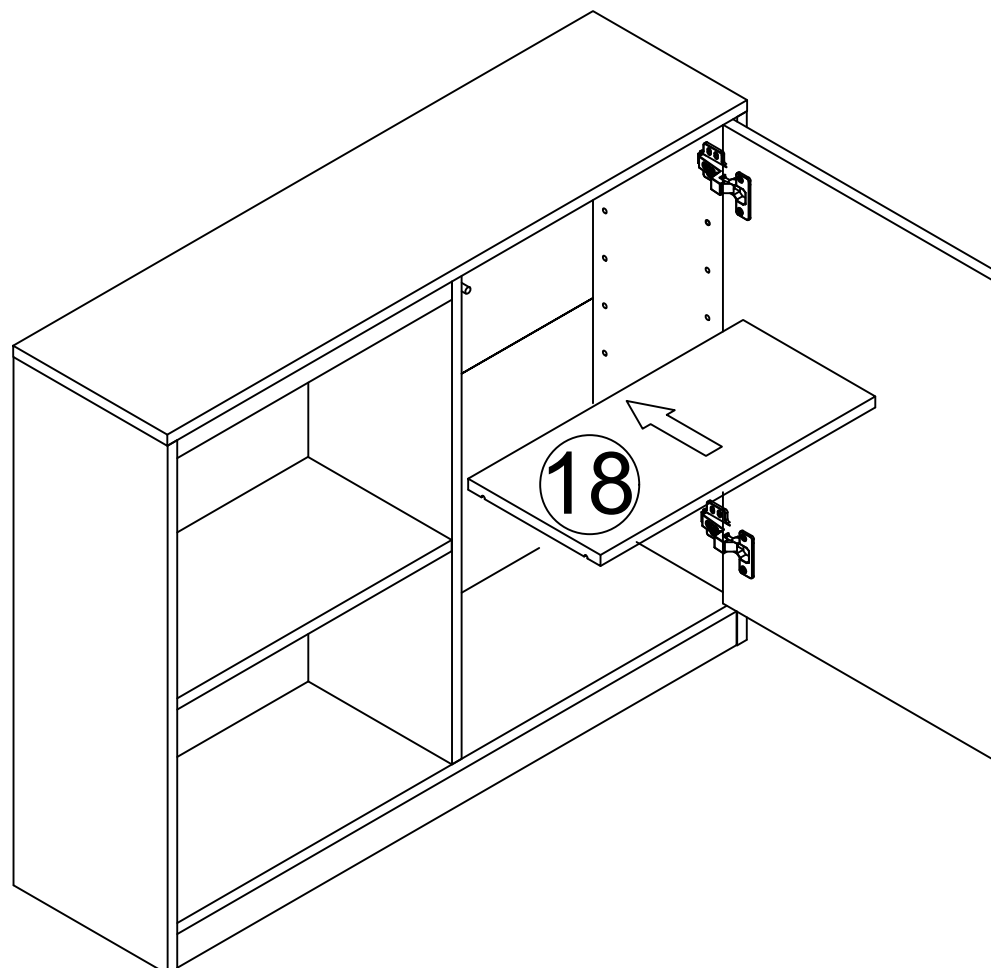

Step 23

Schritt 23



L × 3pcs

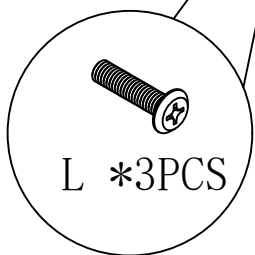
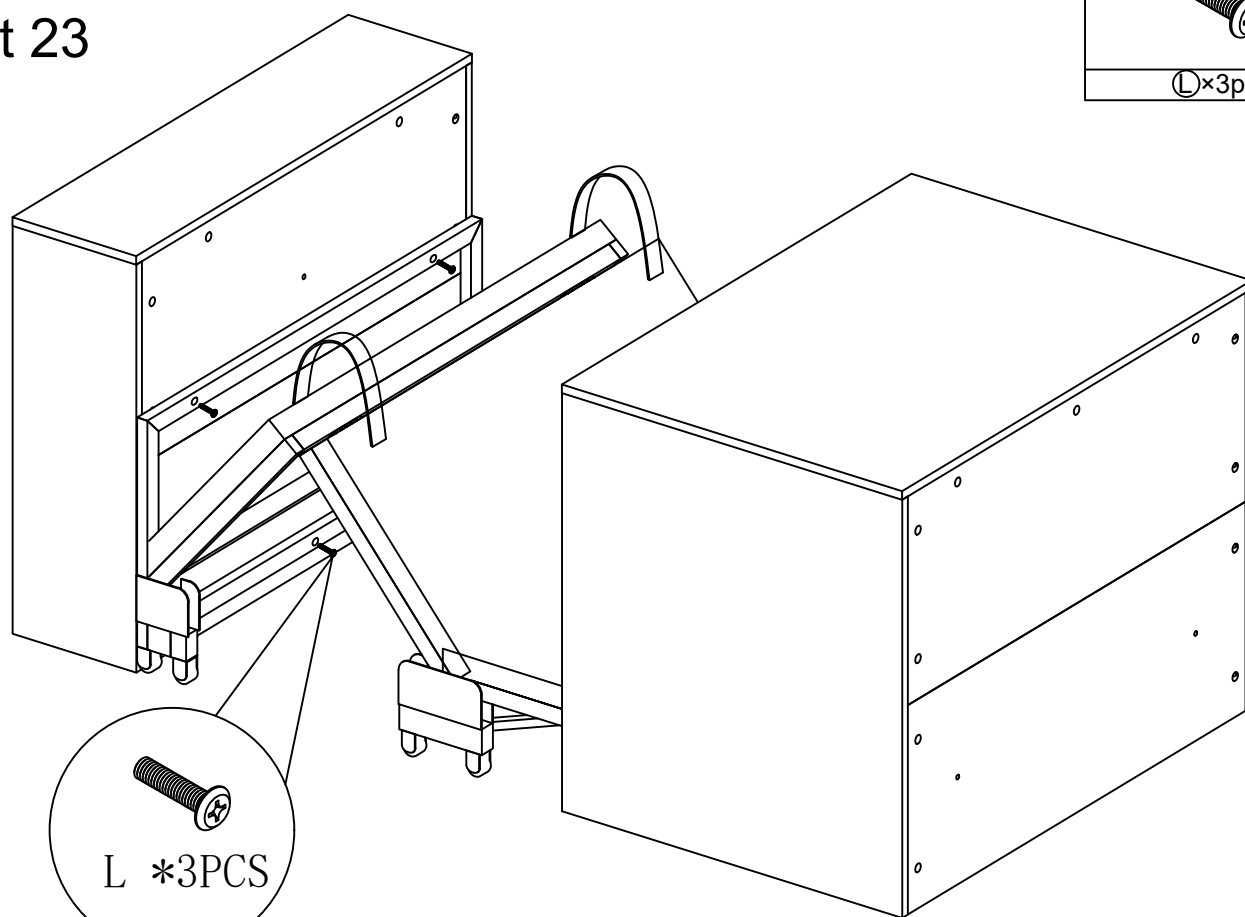

Step 24

Schritt 24

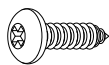

∅5*14mm

F × 2pcs

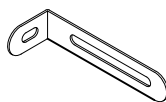

R × 2pcs



S × 2pcs

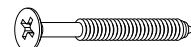

∅5*40mm

U × 2pcs

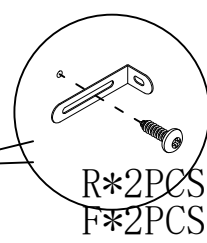
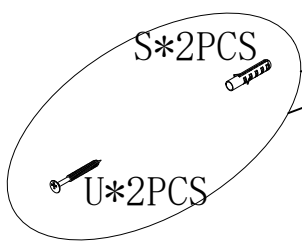
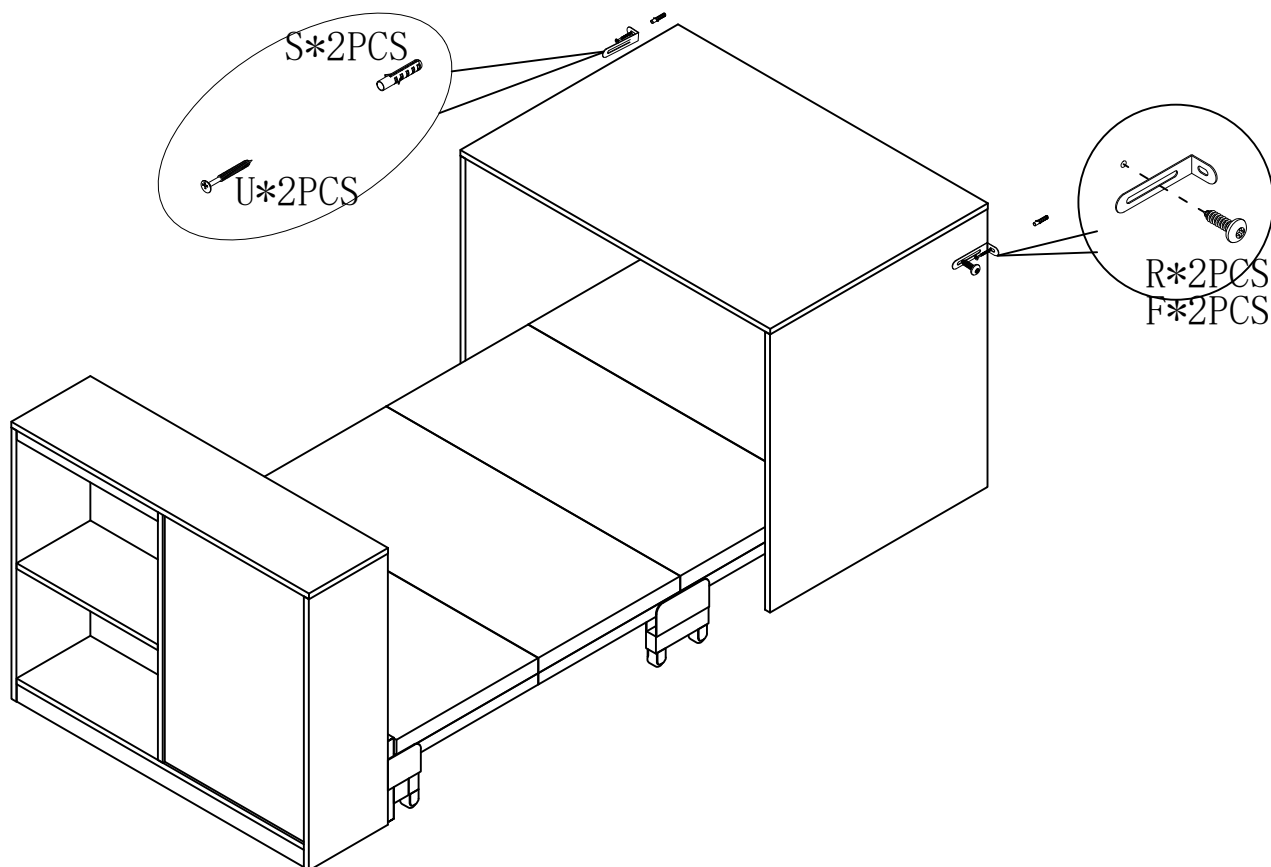

Step 25
Schritt 25



Ⓚ × 8 pcs

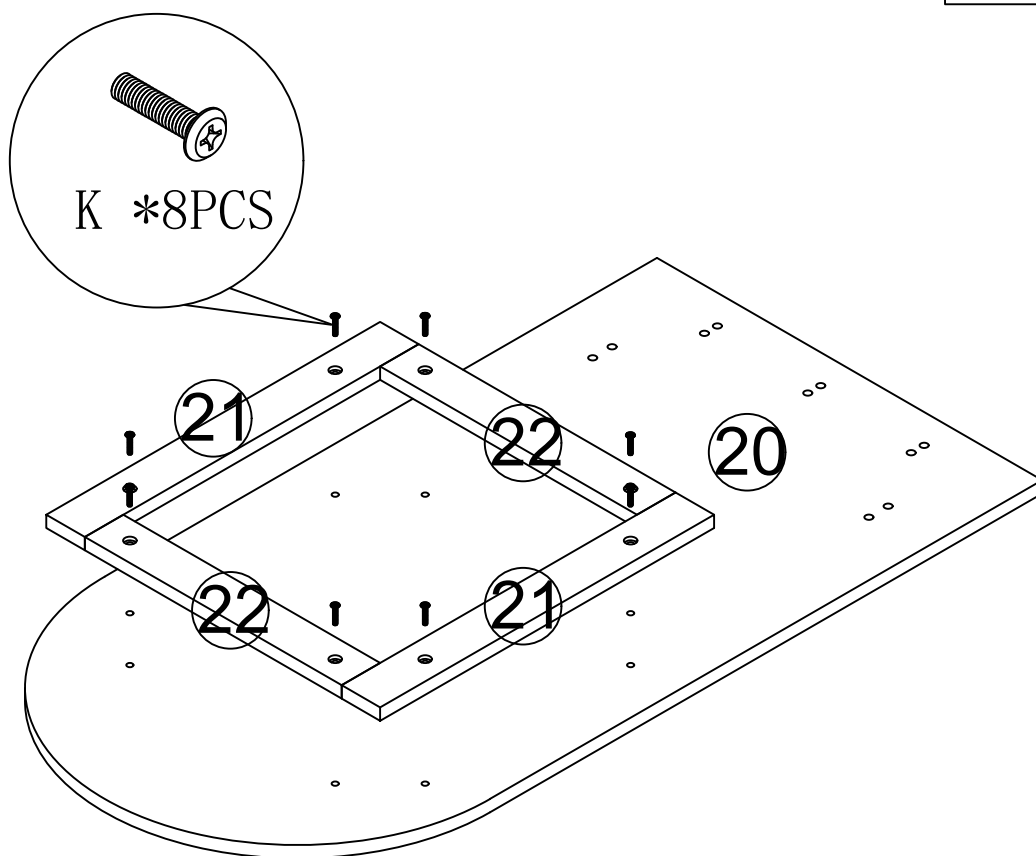

Step 26
Schritt 26

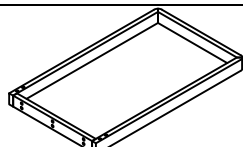

Ⓣ × 1 pcs

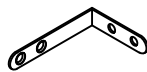

Ⓥ × 2 pcs



∅6*20mm

Ⓦ × 4 pcs



∅6*30mm

Ⓤ × 4 pcs

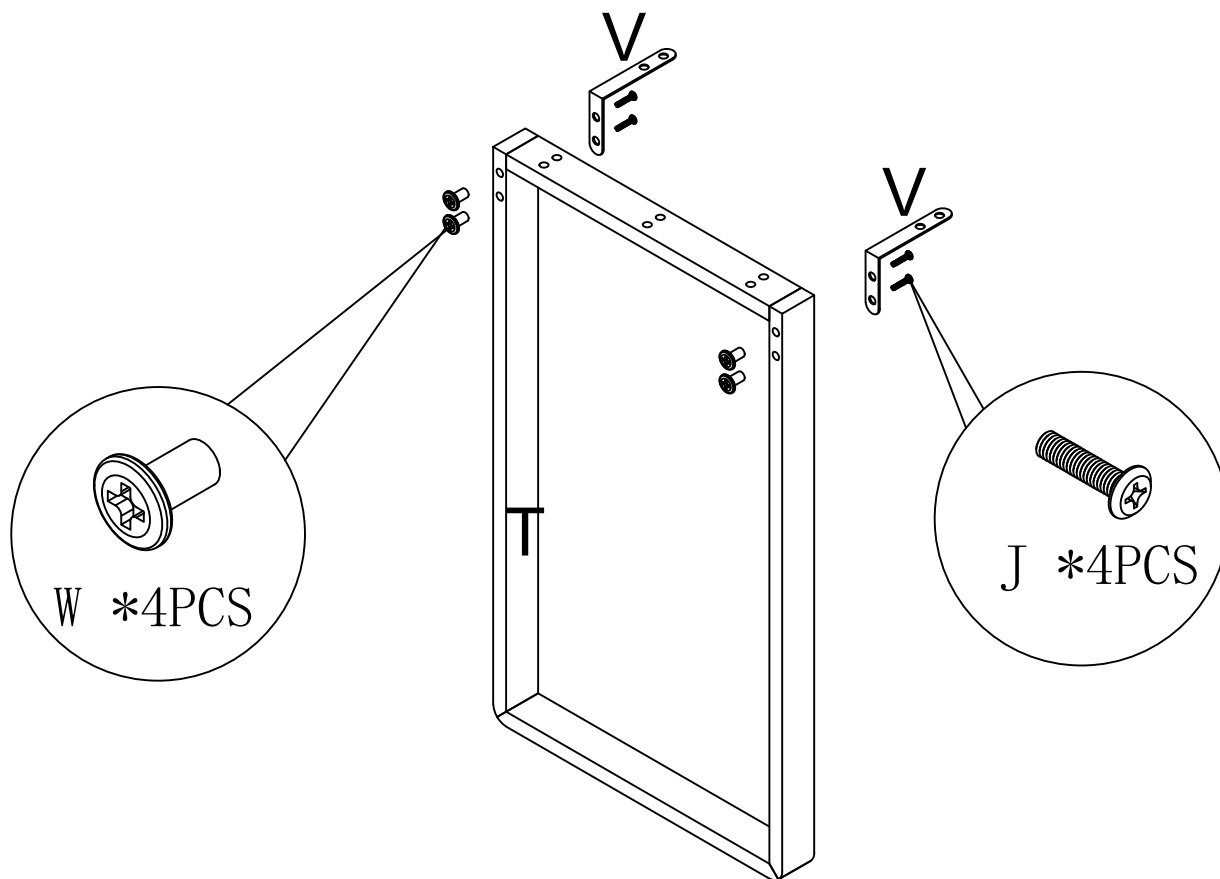

Step 27
Schritt 27

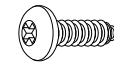

Φ5*14mm

F *4pcs



J *6pcs

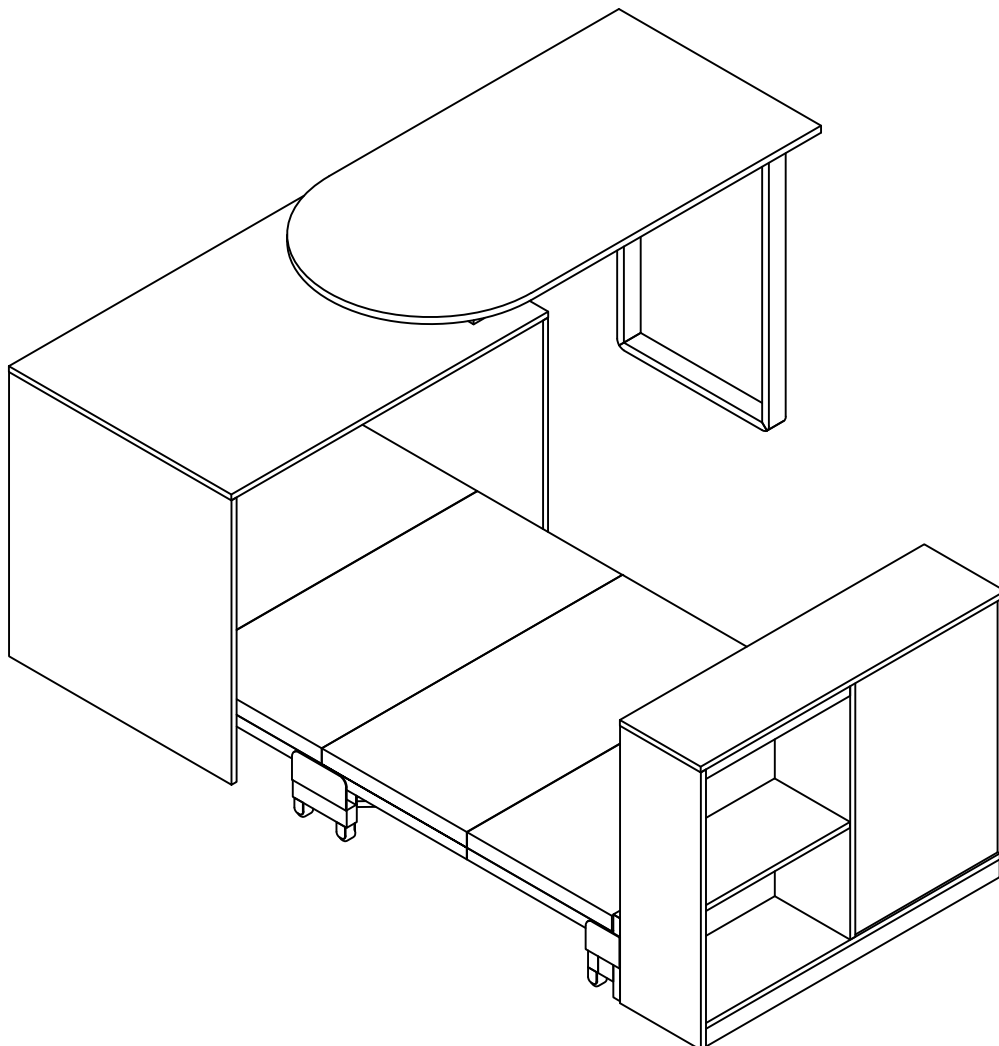
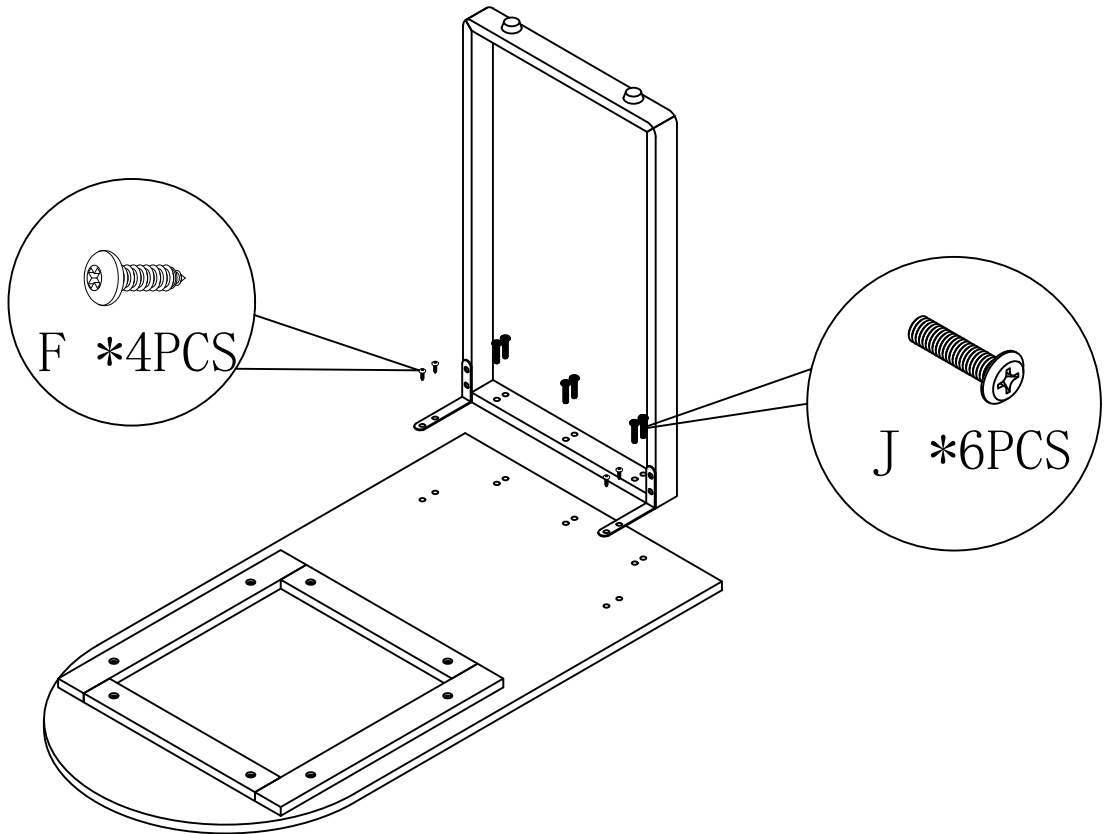

DE:ACHTUNG: Zur Sicherheit und Stabilität empfehlen wir Ihnen, die Kippsicherungszubehörer an der Wand zu befestigen, um ein Umkippen, Verletzungen und Sachschäden zu verhindern.

UK:ATTENTION: For safety and stability, we suggest you have to secure the anti-tip accessories to the wall to prevent tipping, injury, and property damage.

FR:ATTENTION : Pour la sécurité et la stabilité, nous vous recommandons de fixer les accessoires anti-basculement au mur afin d'éviter tout renversement, blessure et dommage matériel.

IT:ATTENZIONE: Per garantire sicurezza e stabilità, ti consigliamo di fissare gli accessori di sicurezza contro il ribaltamento alla parete, per prevenire ribaltamenti, lesioni e danni materiali.

ES:ATENCIÓN: Para garantizar seguridad y estabilidad, le recomendamos que fije los accesorios de seguridad contra el vuelco a la pared para prevenir vuelcos, lesiones y daños materiales.

NL:LETOP: Voor veiligheid en stabiliteit raden wij aan om de anti-kantelaccessoires aan de muur te bevestigen om kantelen, letsel en schade aan eigendommen te voorkomen.

SE:OBS: För säkerhet och stabilitet rekommenderar vi att du fäster anti-tipp-tillbehören på väggen för att förhindra att det tippar, skador och egendomsskador.

Dla bezpieczeństwa i stabilności zalecamy przymocowanie akcesoriów do ściany, aby zapobiec przewróceniu, urazom i uszkodzeniom.



[DE]

Warnung: Lesen Sie die Anleitung vor dem Zusammenbau bitte vollständig durch. Überprüfen Sie, ob Sie alle auf den Seiten aufgeführten Komponenten und Werkzeuge haben.

Warnung: Legen Sie alle Teile auf eine ebene Fläche. Legen Sie eine weiche Decke oder Ähnliches darunter, um sie vor Kratzern oder Flecken zu schützen. Vermeiden Sie es, Komponenten über den Boden zu ziehen oder zu schieben.

Warnung: Überprüfen Sie regelmäßig alle Beschläge und Befestigungen, um sicherzustellen, dass sie sicher sind und um Unfälle zu vermeiden. Wenn Teile fehlen, kaputt, beschädigt oder abgenutzt sind, verwenden Sie das Produkt nicht weiter, bis es mit vom Hersteller autorisierten Teilen repariert wurde.

Warnung: Lassen Sie Kinder nicht auf die Möbel klettern, da dies zum Umkippen und zu schweren Verletzungen führen kann. Bauen Sie die Möbel außerhalb der Reichweite von Kindern zusammen.

Warnung: Stellen Sie die Möbel nicht in die Nähe von Feuerquellen oder heißen Gegenständen, um Brandgefahr zu vermeiden.

Warnung: Reinigen Sie die Möbel mit einem feuchten Tuch oder Alkohol. Verwenden Sie keine Reinigungsmittel mit ätzenden Chemikalien.

Warnung: Dieses Produkt ist mit einer Kippschutzvorrichtung ausgestattet. Bitte installieren Sie diese Vorrichtung unbedingt, um unnötige Verletzungen durch Umkippen zu vermeiden.

[EN]

Warning: Please read instructions fully before starting assembly. Check you have all the components and tools listed on pages.

Warning: Please place all parts on a flat surface. Place a soft blanket or similar underneath to protect against scratches or stains. Avoid dragging or sliding components across the floor.

Warning: Regularly check all fittings and fastenings to ensure they are secure and to prevent accidents. If any parts are missing, broken, damaged, or worn, discontinue use of the product until repairs have been made using factory authorized parts.

Warning: Do not allow children to climb on the furniture as this may result in tipping and serious personal injury. Assemble the furniture away from the reach of children.

Warning: Do not place furniture close to fire sources or high-temperature objects to avoid the risk of fire.

Warning: Clean furniture with a damp cloth or alcohol, avoid using cleaning agents containing corrosive chemicals.

Warning: This product is equipped with an anti-tilt device. Please be sure to install this device to prevent unnecessary injuries caused by tipping.

[FR]

Avertissement : Veuillez lire entièrement les instructions avant de commencer l'assemblage. Vérifiez que vous disposez de tous les composants et outils répertoriés sur les pages.

Avertissement : Veuillez placer toutes les pièces sur une surface plane. Placez une couverture douce ou similaire en dessous pour les protéger des rayures ou des taches. Évitez de faire glisser les composants sur le sol.

Avertissement : Vérifiez régulièrement tous les raccords et fixations pour vous assurer qu'ils sont bien fixés et pour éviter les accidents. Si des pièces manquent, sont cassées, endommagées ou usées, cessez d'utiliser le produit jusqu'à ce que des réparations aient été effectuées à l'aide de pièces autorisées par l'usine.

Avertissement : Ne laissez pas les enfants grimper sur les meubles car cela pourrait entraîner un basculement et des blessures graves. Assemblez les meubles hors de portée des enfants.

Avertissement : Ne placez pas les meubles à proximité de sources de feu ou d'objets à haute température pour éviter tout risque d'incendie.



Avertissement : Nettoyez les meubles avec un chiffon humide ou de l'alcool, évitez d'utiliser des produits de nettoyage contenant des produits chimiques corrosifs.

Avertissement : Ce produit est équipé d'un dispositif anti-basculement. Assurez-vous d'installer ce dispositif pour éviter les blessures inutiles causées par un basculement.

[IT]

Attenzione: leggere attentamente le istruzioni prima di iniziare il montaggio. Verificare di avere tutti i componenti e gli strumenti elencati nelle pagine.

Attenzione: posizionare tutte le parti su una superficie piana. Posizionare una coperta morbida o simile sotto per proteggere da graffi o macchie. Evitare di trascinare o far scivolare i componenti sul pavimento.

Attenzione: controllare regolarmente tutti i raccordi e i dispositivi di fissaggio per assicurarsi che siano sicuri e per prevenire incidenti. Se alcune parti sono mancanti, rotte, danneggiate o usurate, interrompere l'uso del prodotto fino a quando non siano state eseguite le riparazioni utilizzando parti autorizzate dalla fabbrica.

Attenzione: non consentire ai bambini di arrampicarsi sui mobili poiché ciò potrebbe causare ribaltamenti e gravi lesioni personali. Montare i mobili lontano dalla portata dei bambini.

Attenzione: non posizionare i mobili vicino a fonti di fuoco o oggetti ad alta temperatura per evitare il rischio di incendio.

Attenzione: pulire i mobili con un panno umido o alcol, evitare di utilizzare detergenti contenenti sostanze chimiche corrosive.

Attenzione: questo prodotto è dotato di un dispositivo antiribaltamento. Assicurarsi di installare questo dispositivo per prevenire lesioni inutili causate dal ribaltamento.

[ES]

Advertencia: Lea las instrucciones completamente antes de comenzar el montaje. Compruebe que tiene todos los componentes y herramientas que se enumeran en las páginas.

Advertencia: Coloque todas las piezas sobre una superficie plana. Coloque una manta suave o algo similar debajo para protegerlas de rayones o manchas. Evite arrastrar o deslizar los componentes por el piso.

Advertencia: Verifique regularmente todos los accesorios y fijaciones para asegurarse de que estén seguros y evitar accidentes. Si falta alguna pieza, esté rota, dañada o desgastada, deje de usar el producto hasta que se hayan realizado las reparaciones con piezas autorizadas de fábrica.

Advertencia: No permita que los niños se suban a los muebles, ya que esto puede provocar que se vuelquen y lesiones personales graves. Monte los muebles fuera del alcance de los niños.

Advertencia: No coloque los muebles cerca de fuentes de fuego u objetos de alta temperatura para evitar el riesgo de incendio.

Advertencia: Limpie los muebles con un paño húmedo o alcohol, evite usar agentes de limpieza que contengan químicos corrosivos.

Advertencia: Este producto está equipado con un dispositivo antivuelco. Asegúrese de instalar este dispositivo para evitar lesiones innecesarias causadas por vuelcos.