

CHLOE

SZAFA 3D

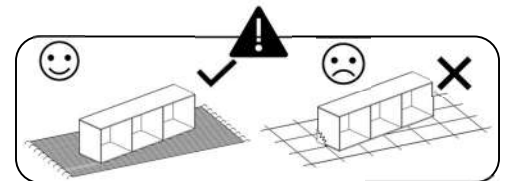

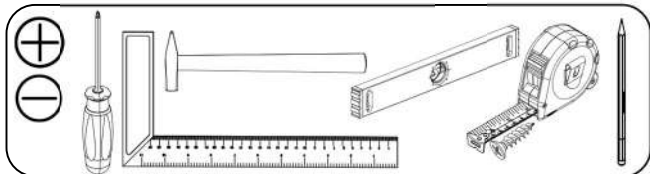
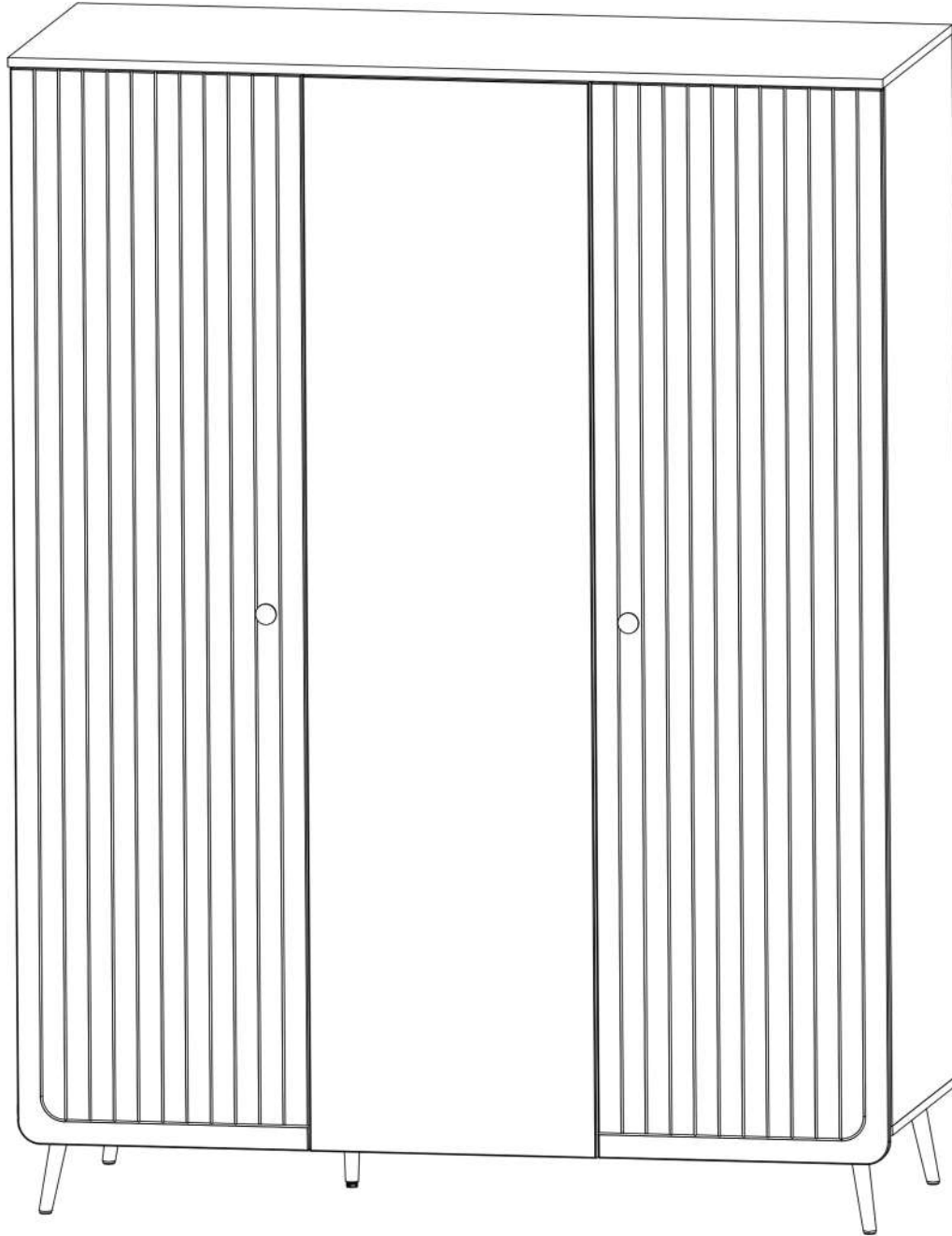
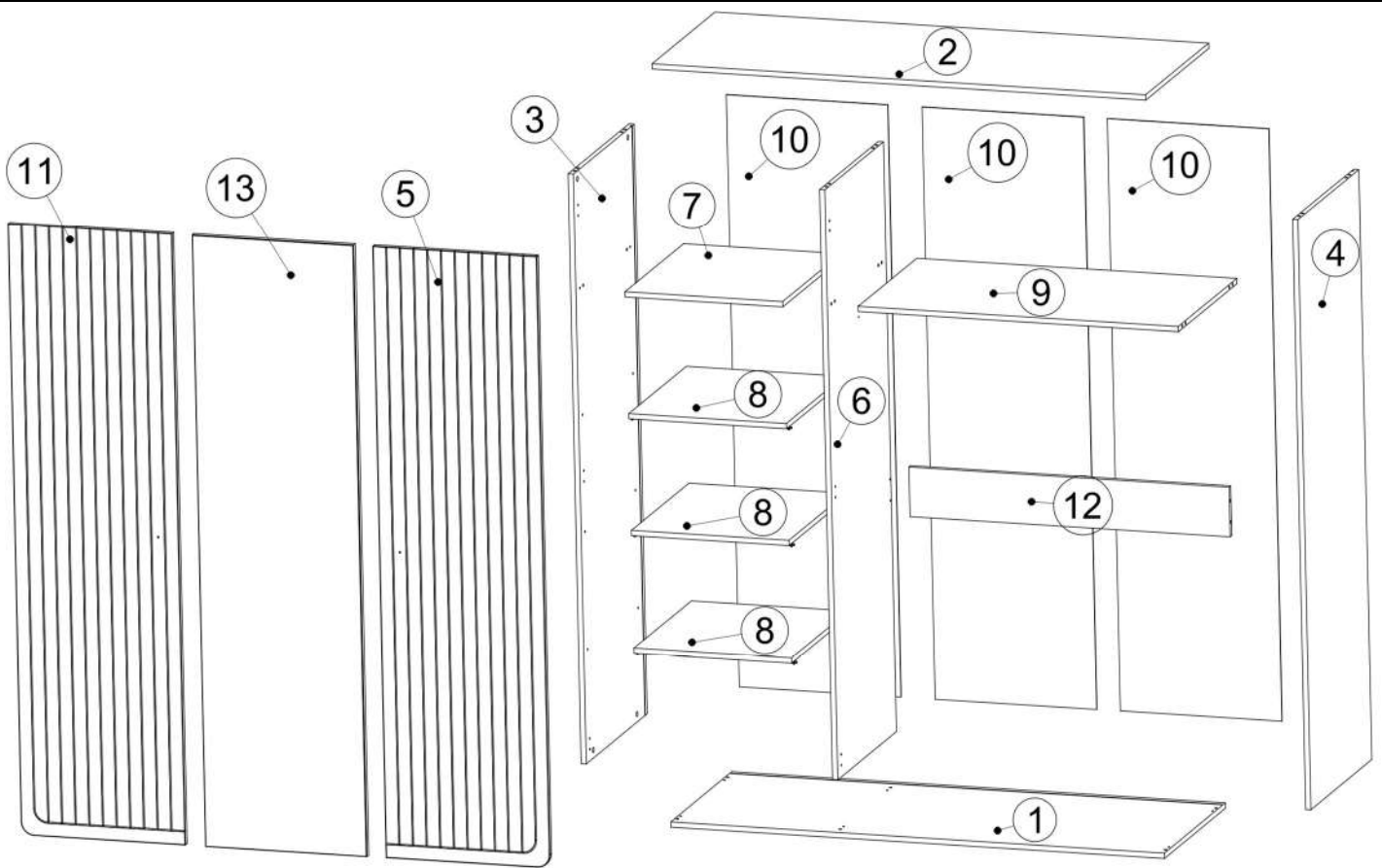

No	T(mm)	L(mm)	W(mm)	pcs.
1	16	1516	580	1
2	16	1516	600	1
3	16	1788	580	1
4	16	1788	580	1
5	16	1850	504	1
6	16	1788	558	1
7	16	558	484	1
8	16	484	550	3
9	16	558	983	1
10	3	1796	496	3
11	16	1850	504	1
12	16	983	150	1
13	16	1850	496	1

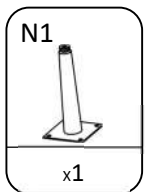
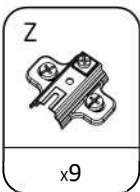
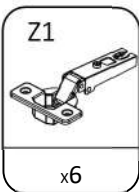
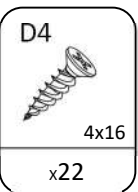
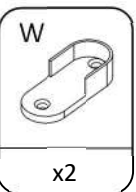
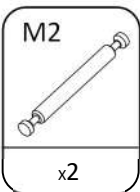
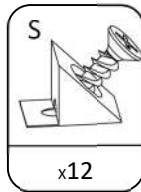
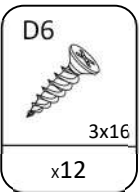
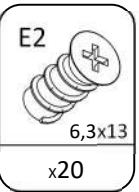
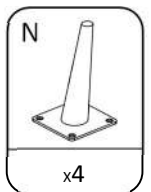
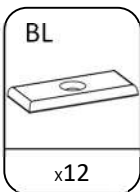
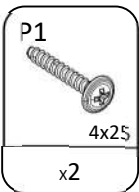
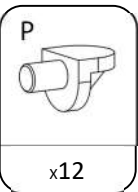
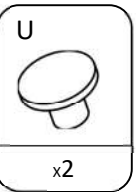
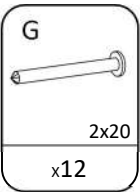
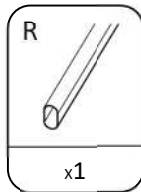
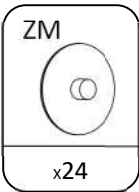
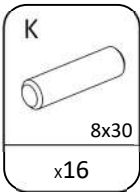
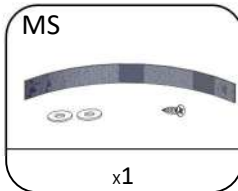
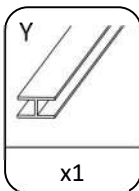
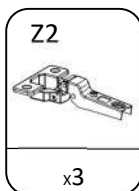
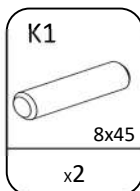
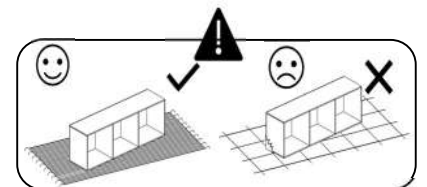

1

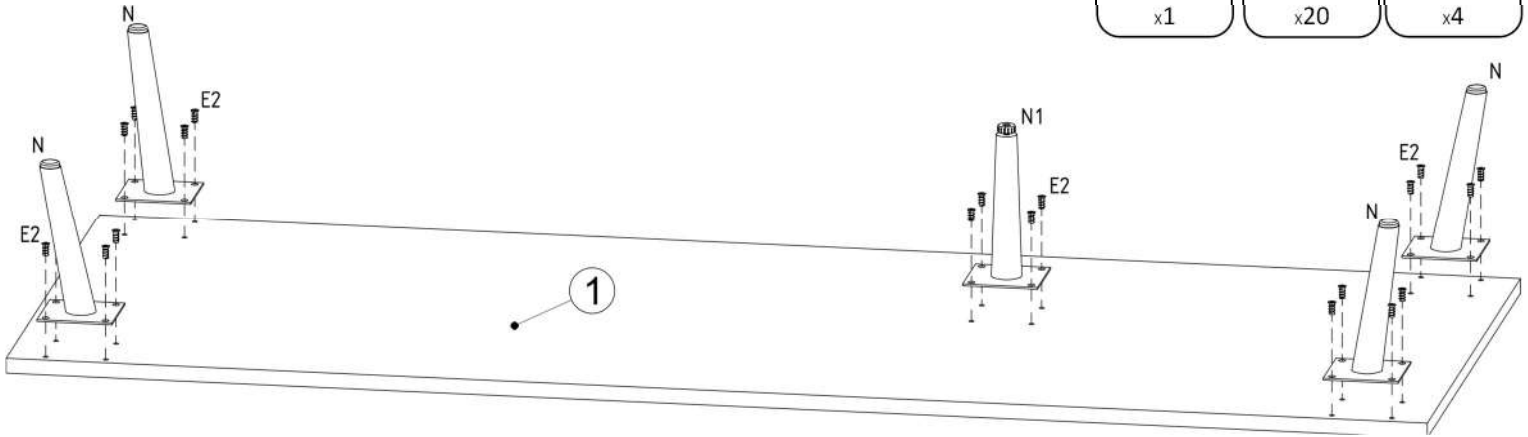
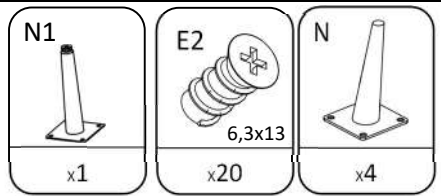

2

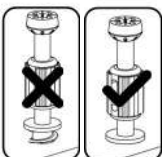
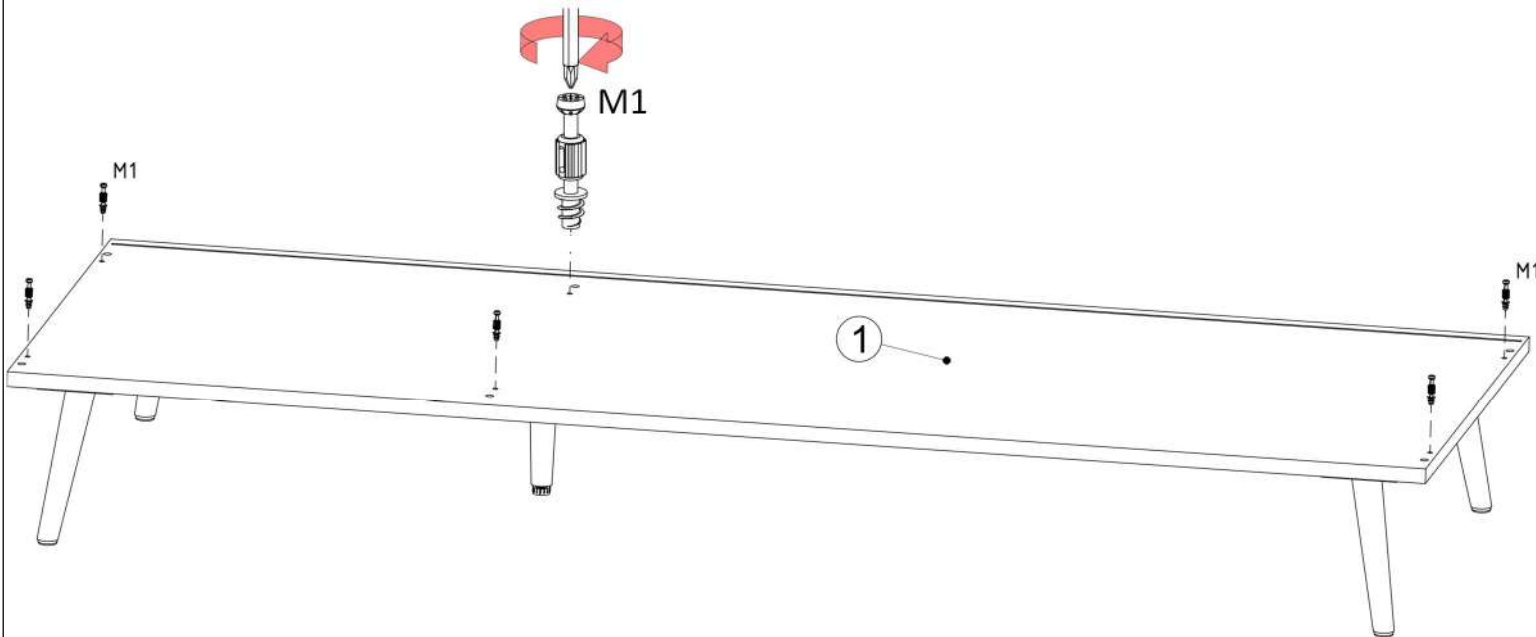
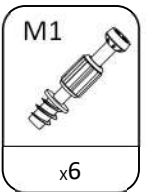

3

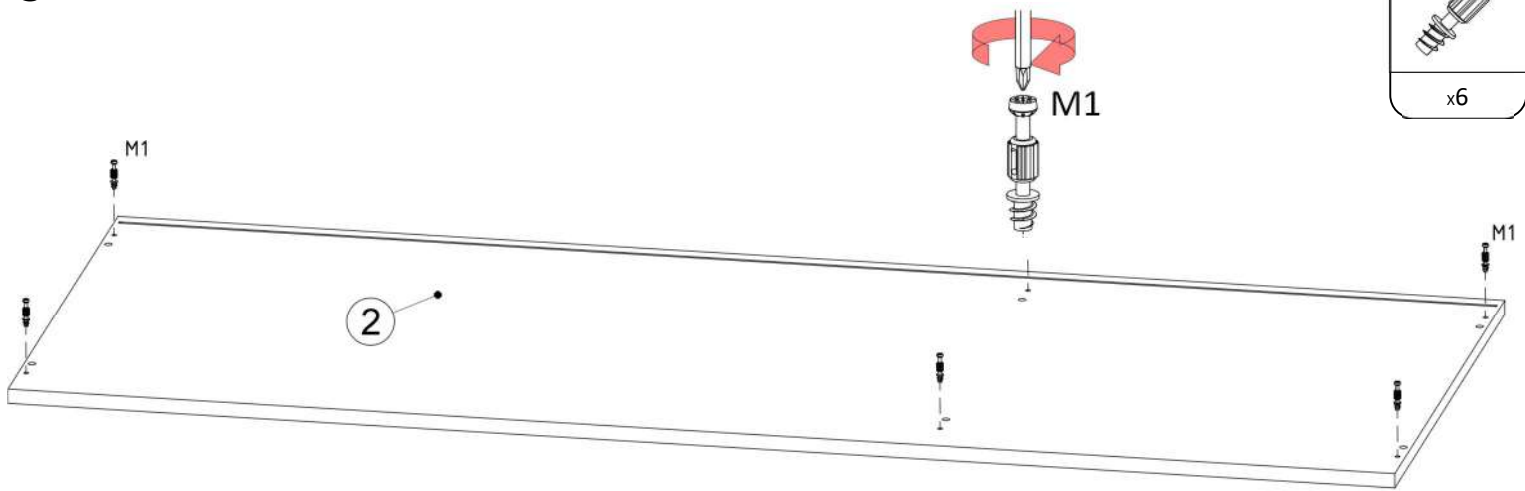

M1

x6

2

M1

M1

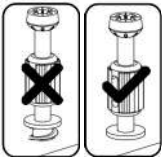

4

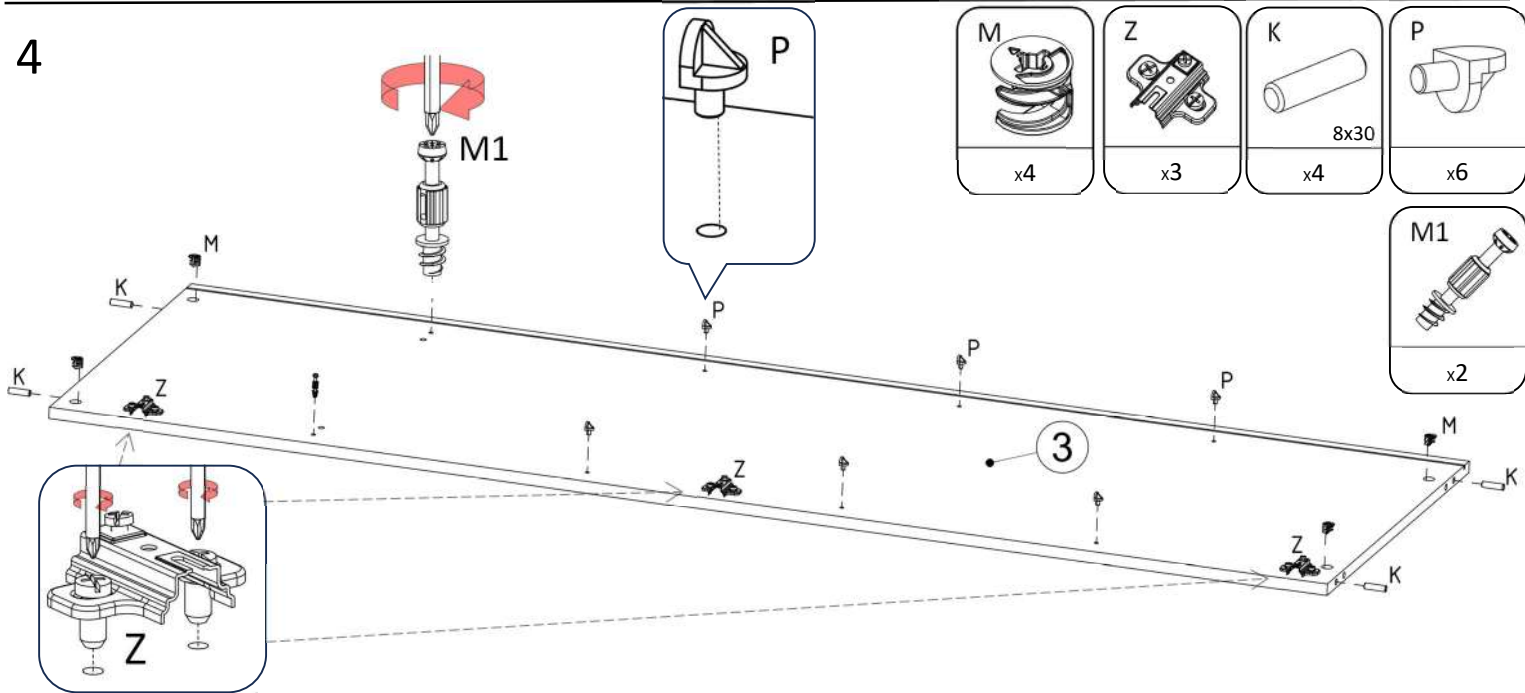

M

x4

Z

x3

K

8x30

x4

P

x6

M1

x2

M

Z

K

P

3

Z

Z

Z

Z

Z

Z

Z

Z

Z

Z

Z

Z

Z

5

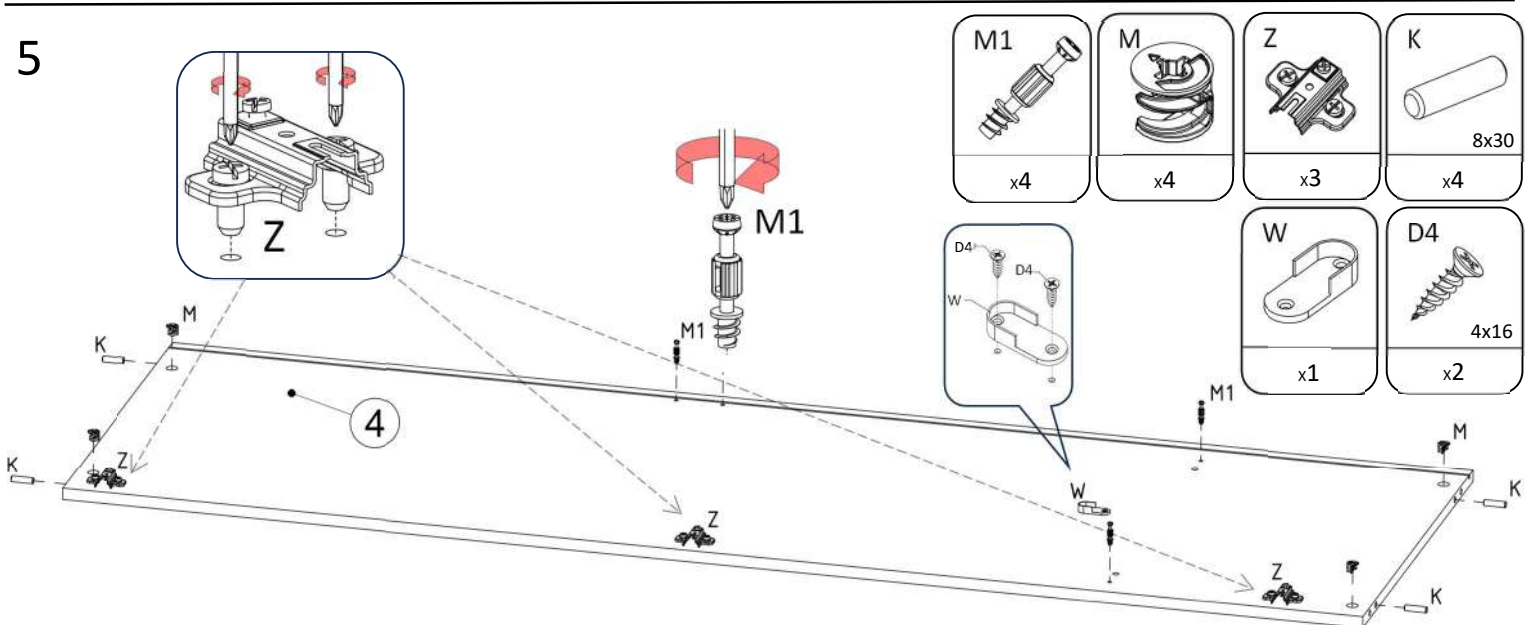

M1

x4

M

x4

Z

x3

K

8x30

x4

D4

W

D4

W

D4

W

D4

W

D4

W

W

x1

D4

4x16

x2

4

Z

Z

Z

Z

Z

Z

Z

Z

Z

Z

Z

Z

Z

Z

Z

Z

6

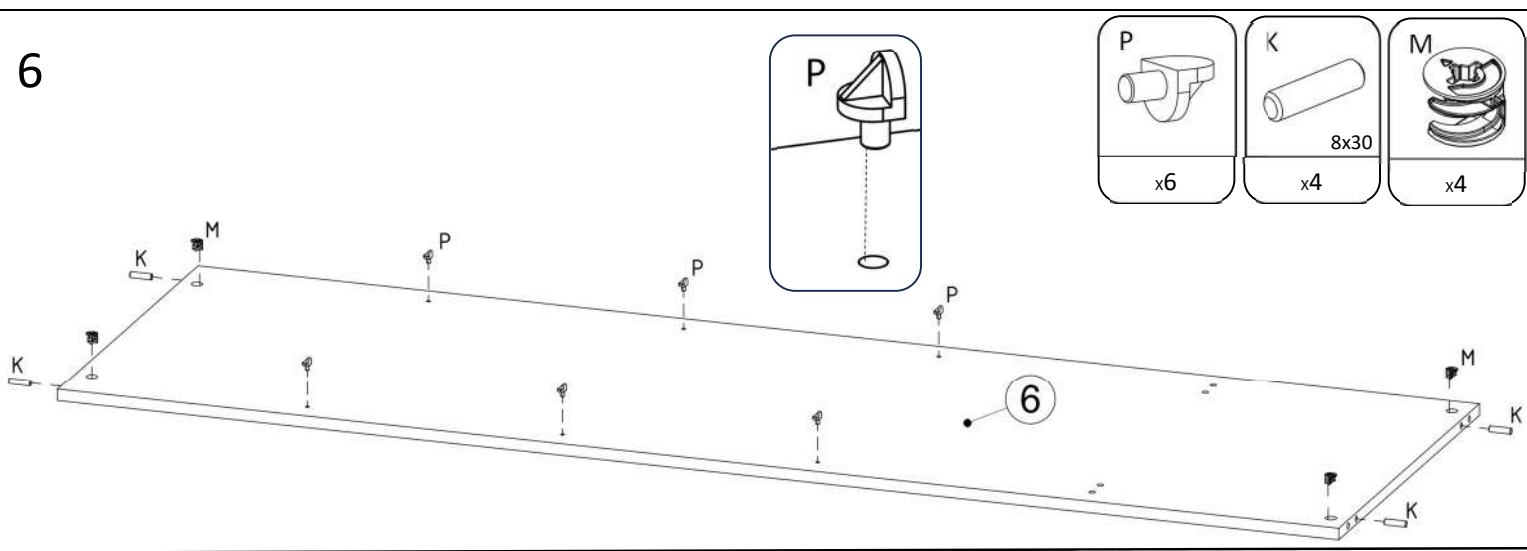

7

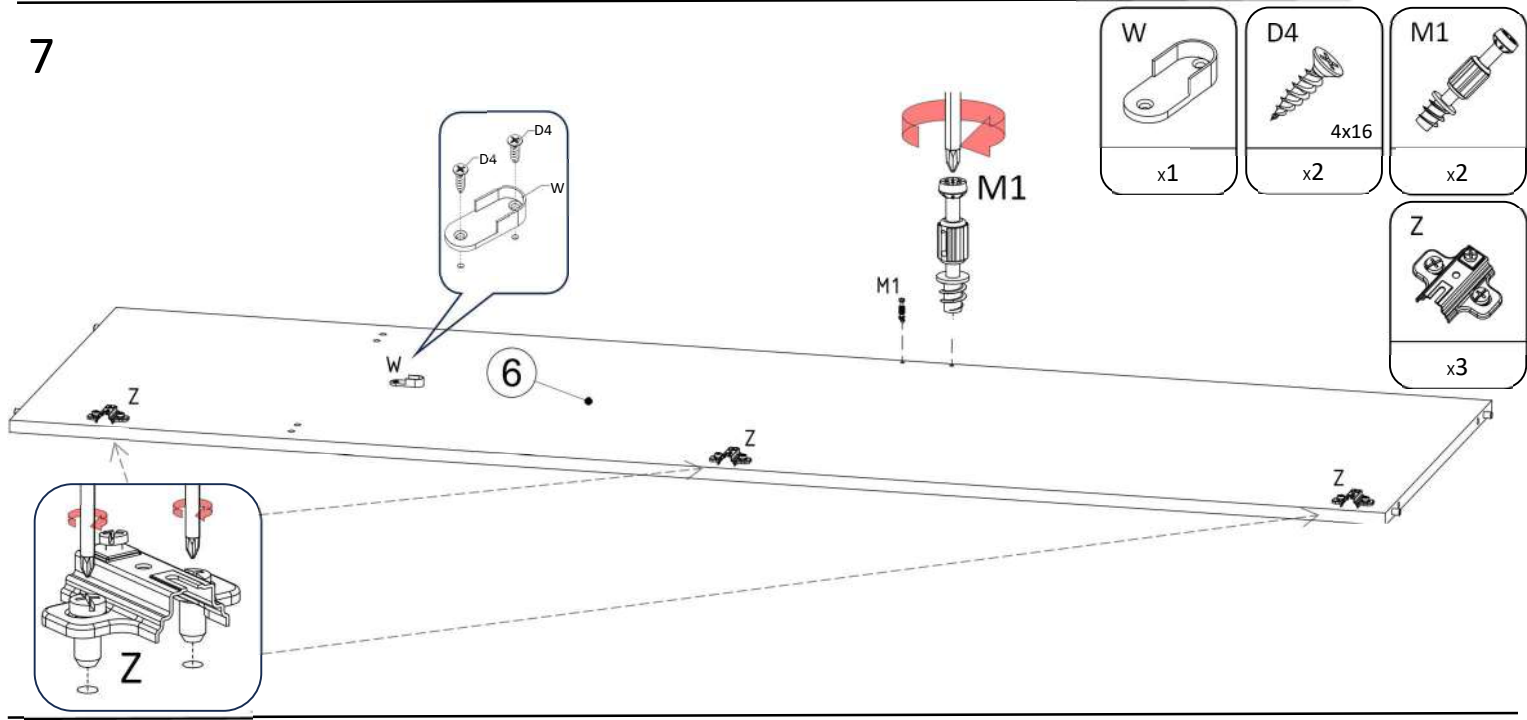

8

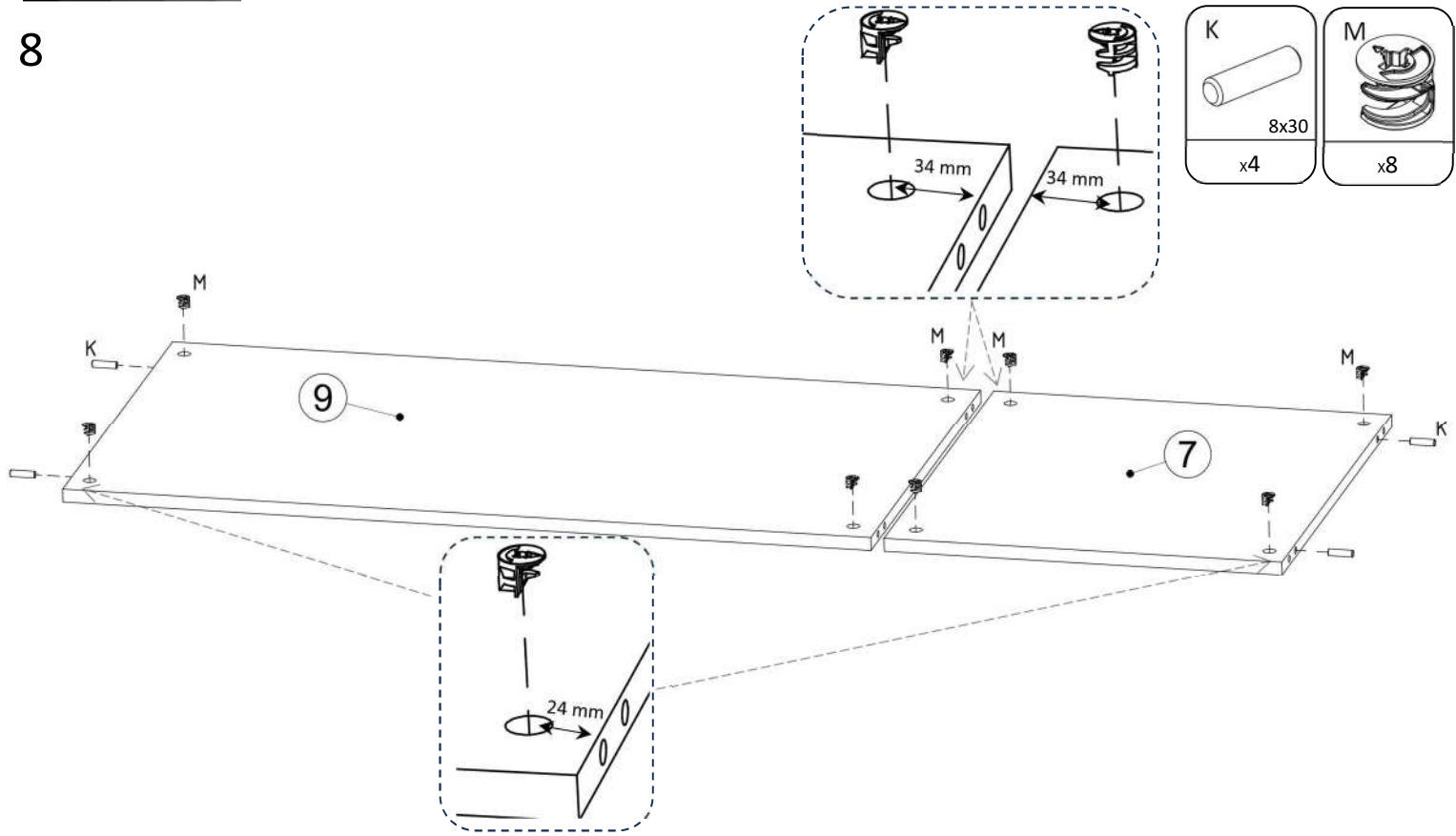

9

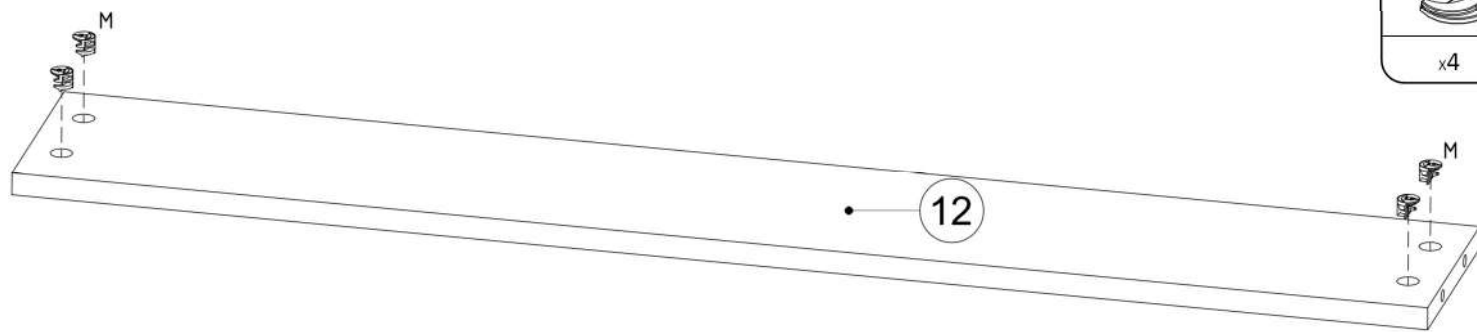

10

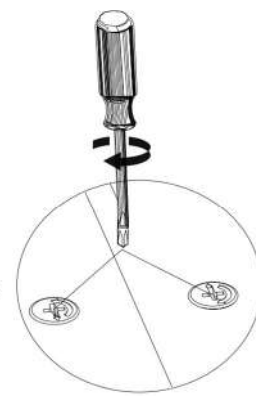
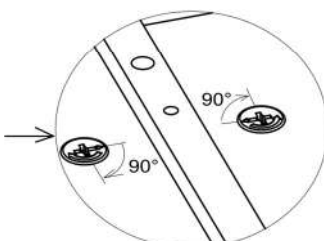
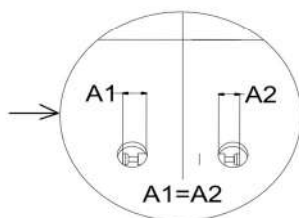
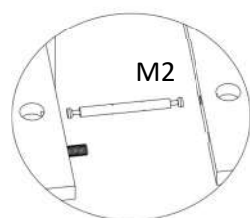
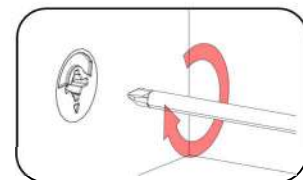
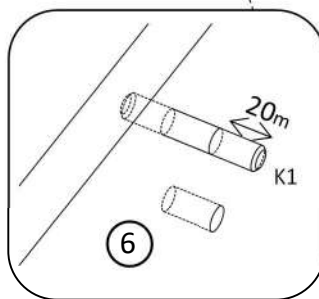
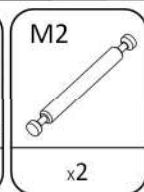
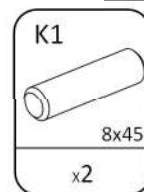
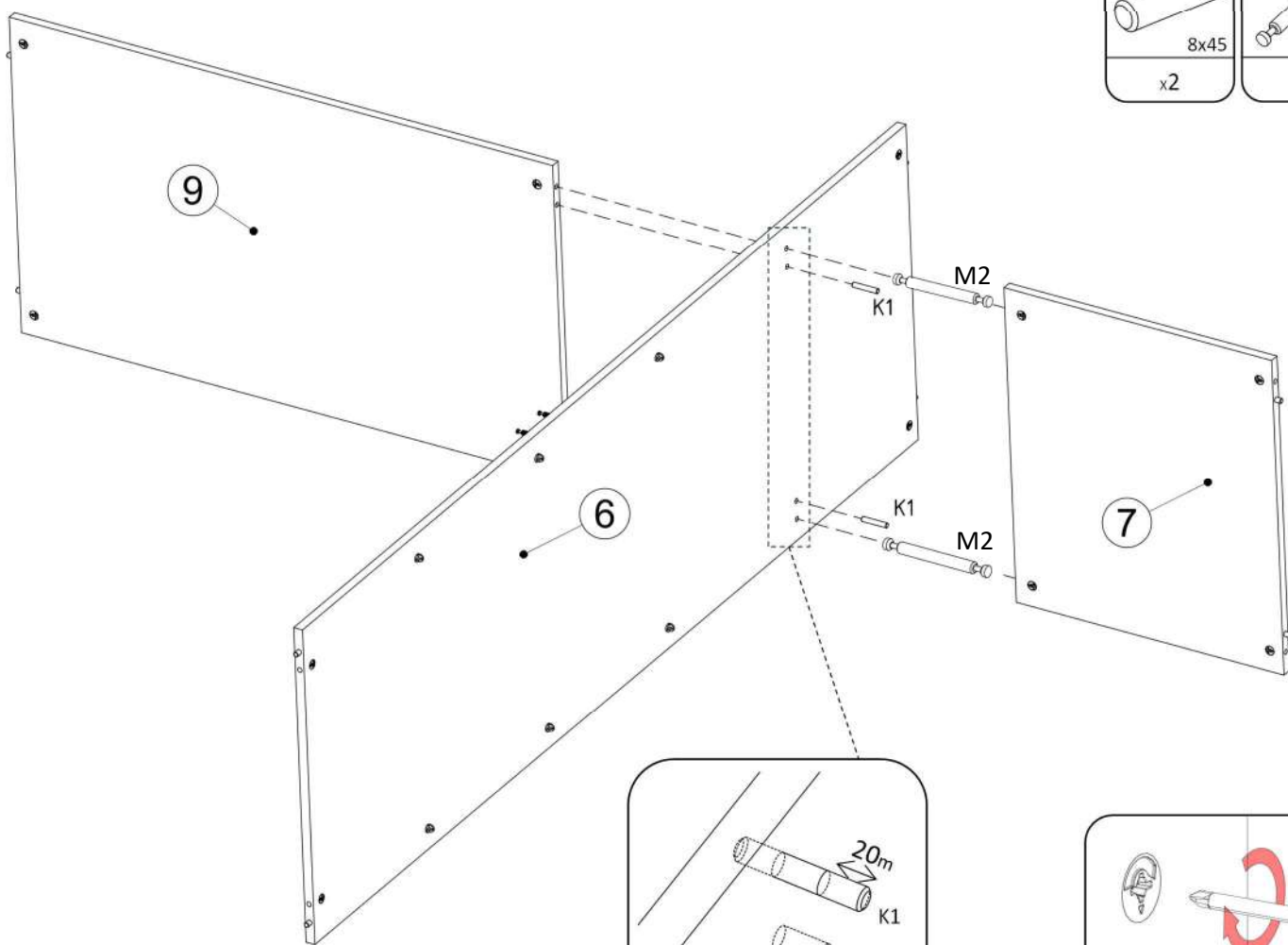

11

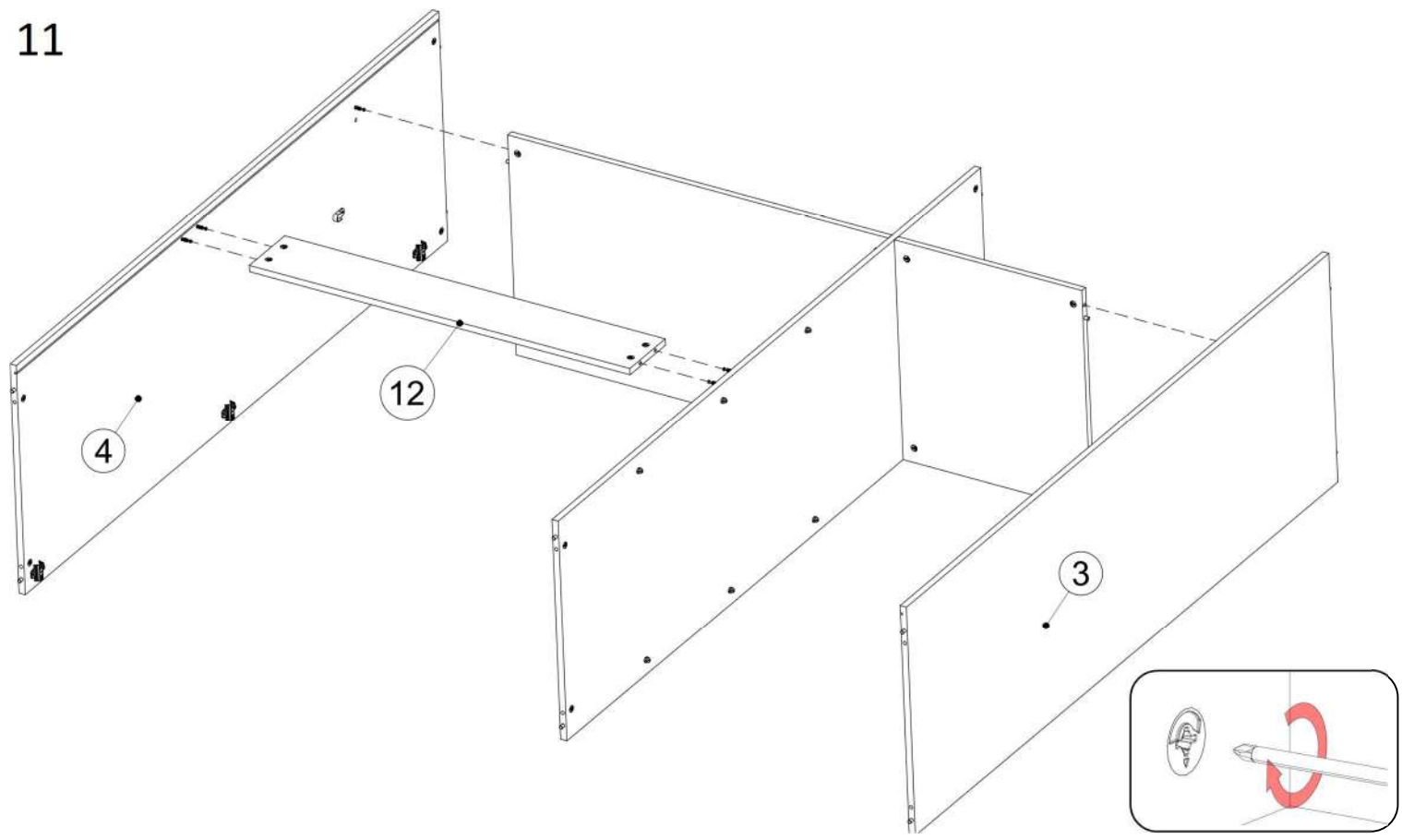

12

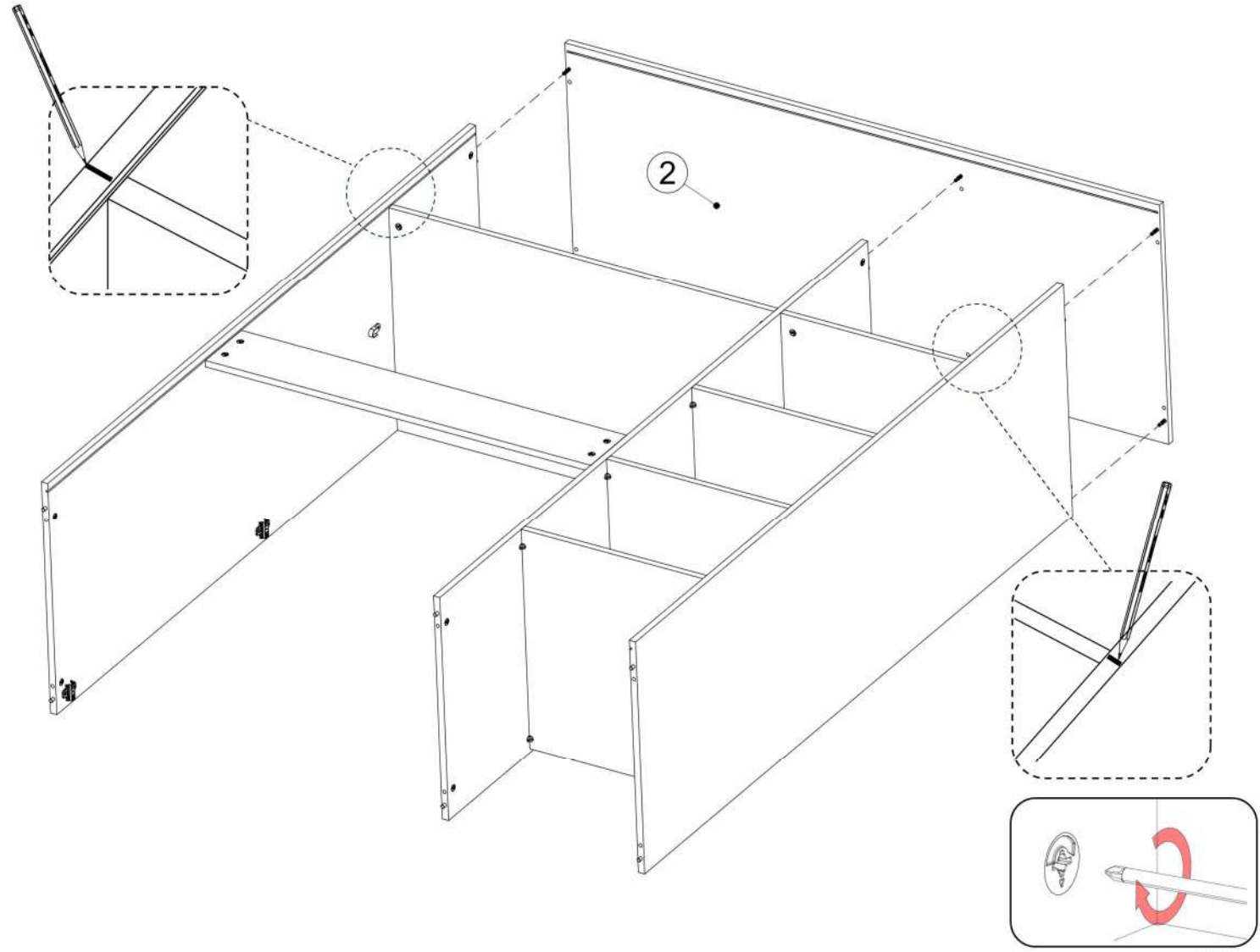

15

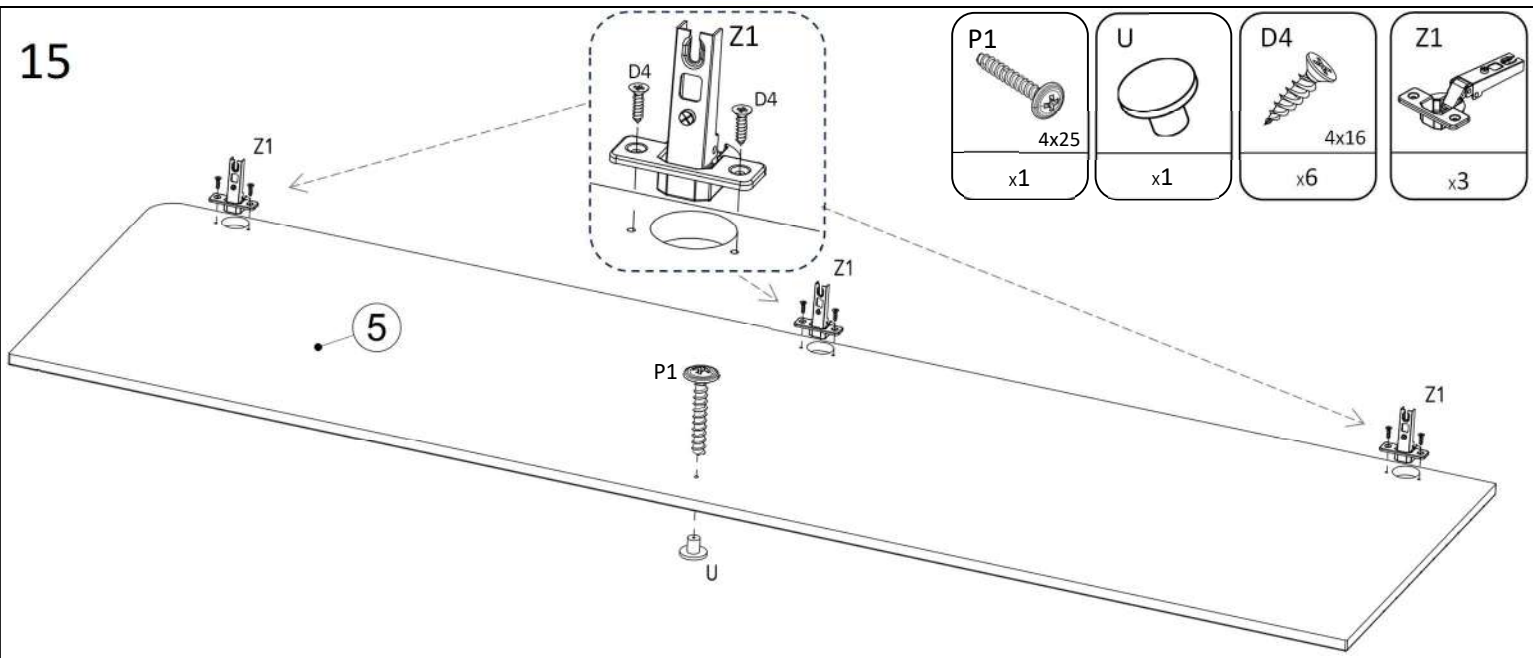

16

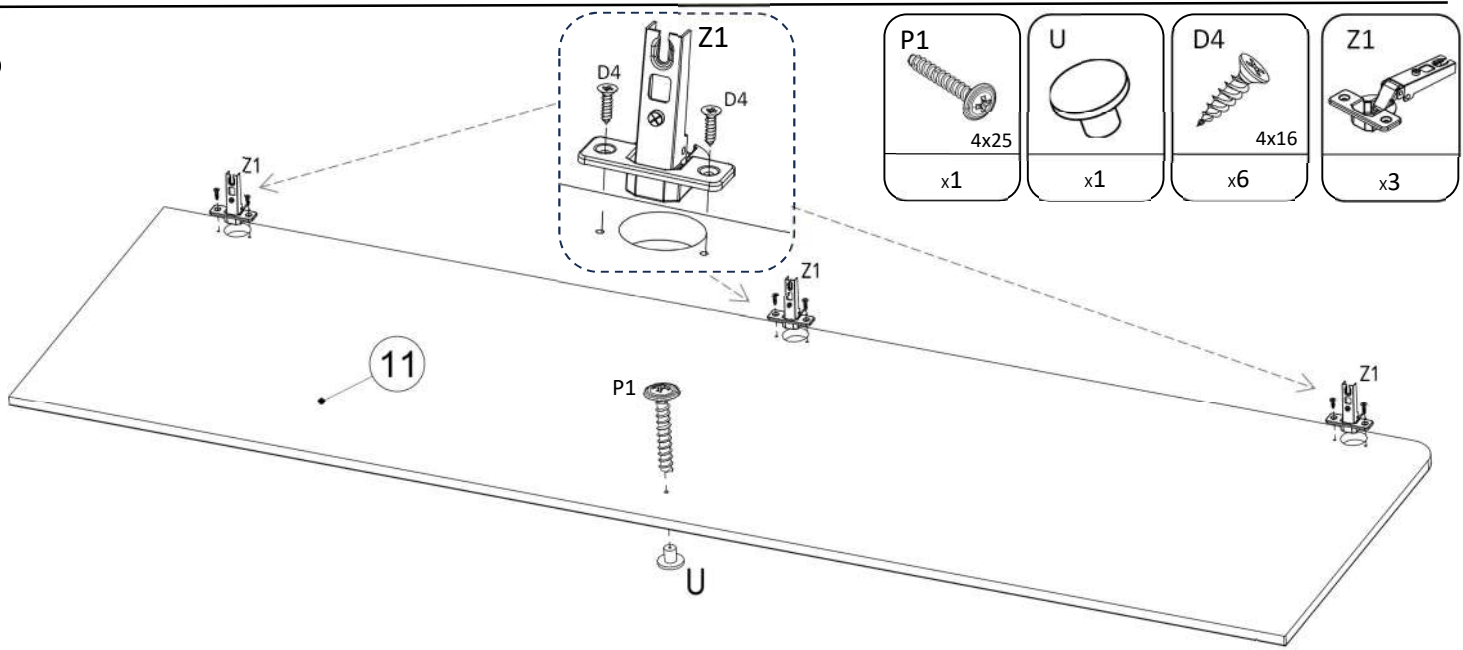

17

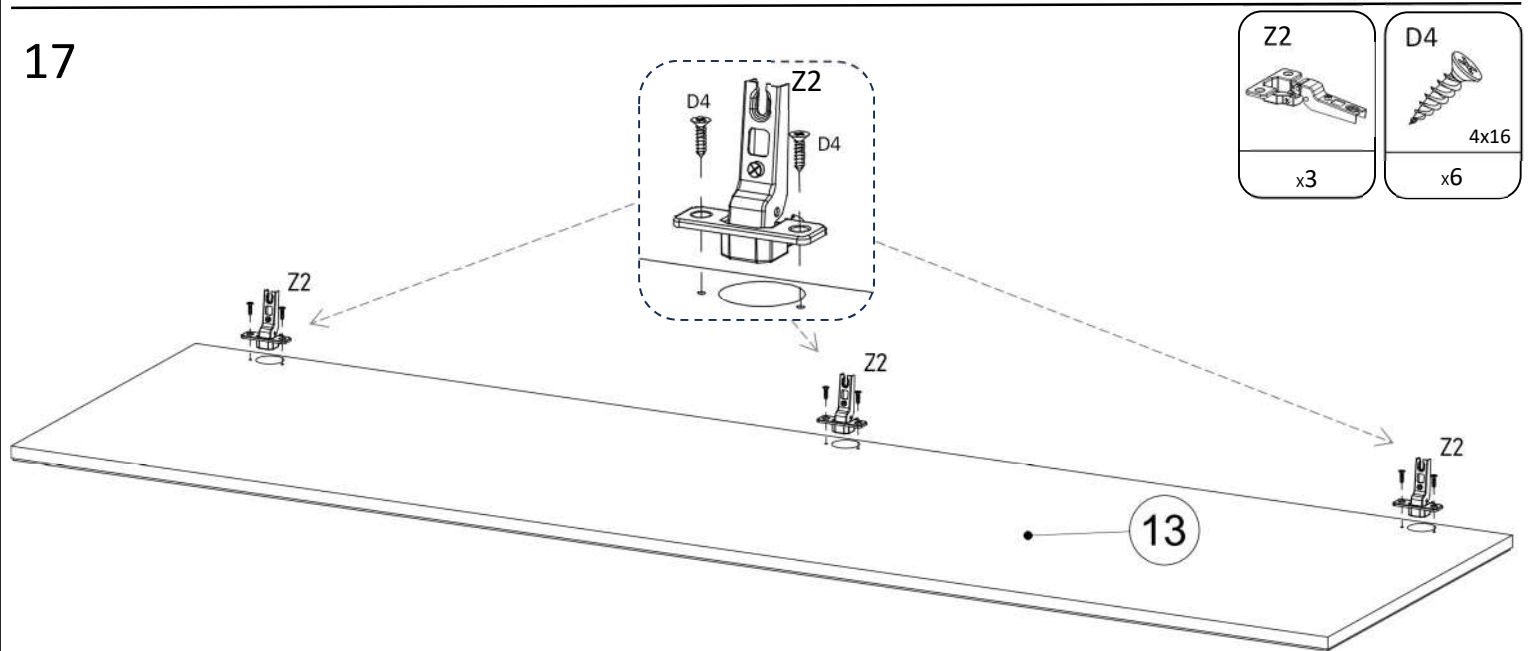

18

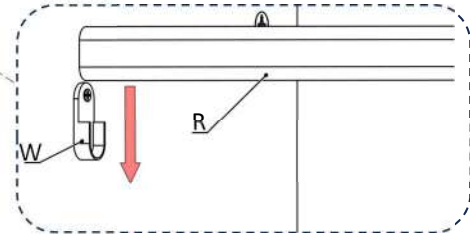
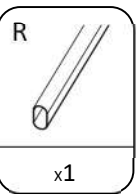
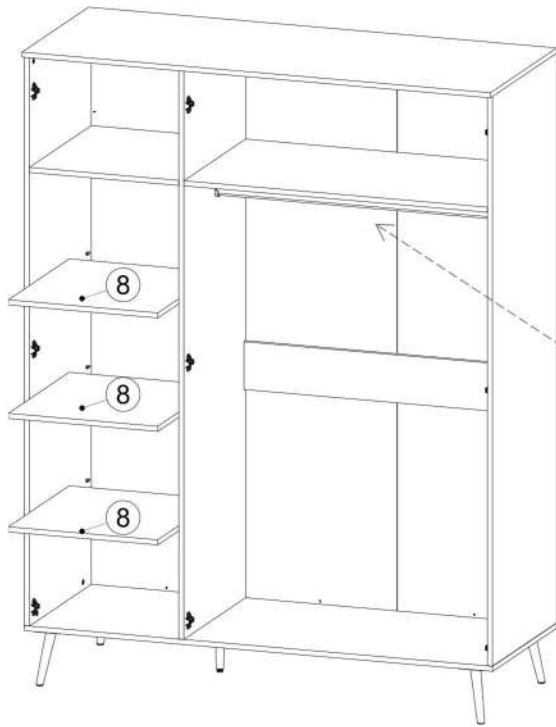

19

