

Installation sanleitung
Installation Instruction
Instruction d'installation

Bett 140×200

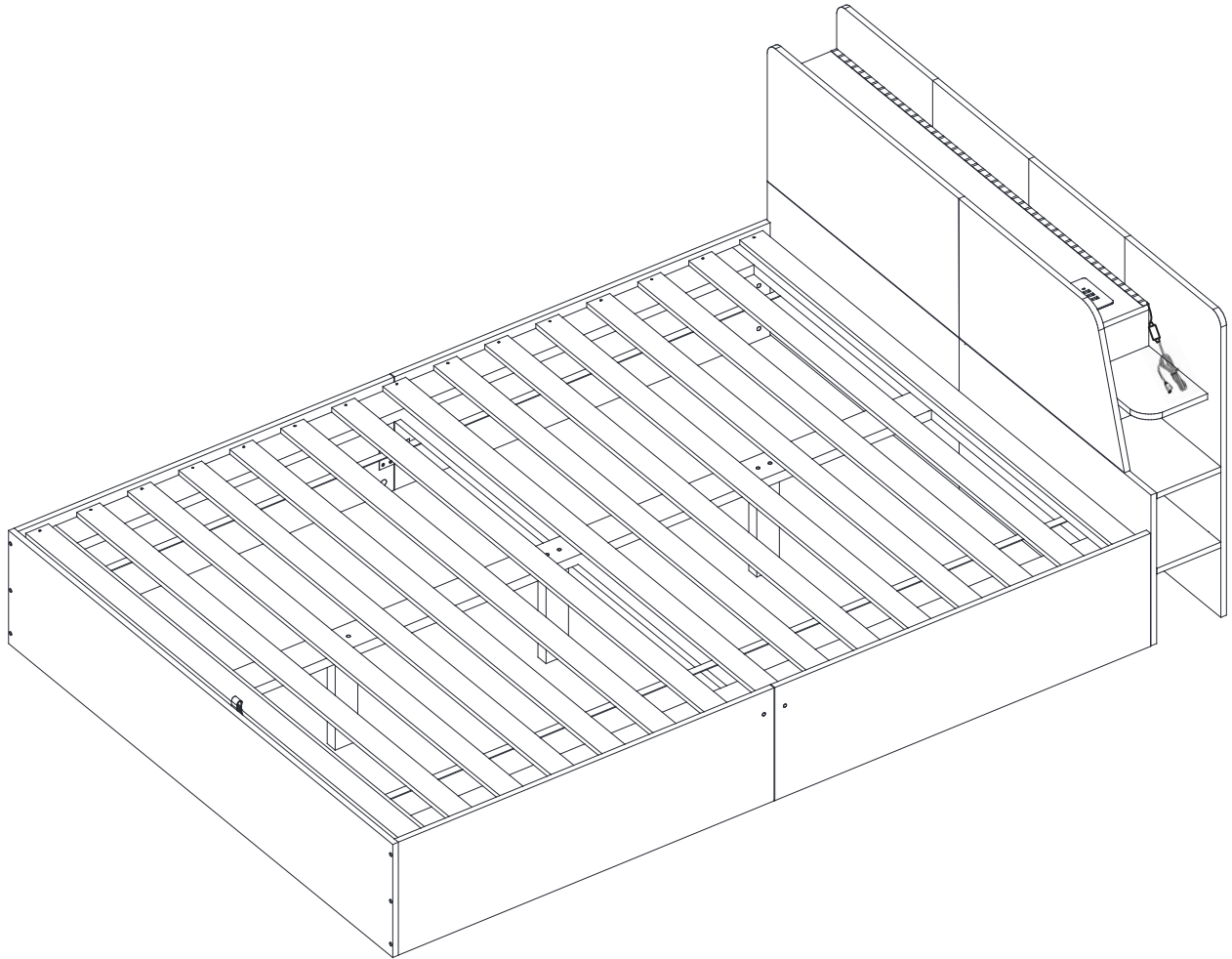

DE: Unser Produkt wird Ihnen in 3 Paketen geliefert. Die Lieferzeiten dieser 3 Pakete können abweichen, bitte haben Sie etwas Geduld und vielen Dank für Ihr Verständnis.

UK: Our product will be delivered to you in 3 packages. The delivery times of these 3 packages may differ, please be patient and thank you for your understanding.

FR: Notre produit vous sera livré en 3 colis. Les délais de livraison de ces 3 colis peuvent différer, soyez patient et merci pour votre compréhension.



FR

Vous êtes responsable de remettre tous les appareils électriques et électroniques usagés à des points de collecte correspondants.

Pour en savoir plus:
www.quefairedemesdechets.fr

N636P379689/N636P379690/N636P379691

INSTRUCTIONS

IMPORTANT-READ CAREFULLY-RETAIN FOR FUTURE REFERENCE

- a) **WARNING** -Children can become trapped between the bed and the wall, the adjoining pieces of furniture (e.g. cupboards) and the like. To avoid risk of serious injury the distance between the safety barrier and the adjoining structure shall not exceed 75 mm or shall be more than 230 mm.
- b) **WARNING**-Do not use the bed if any structural part is broken or missing; Replacement parts are between requested from the manufacturer or the store.
- c) **WARNING**-Do not climb or wiggle on any non-designated structures.
- d) it is imperative to always follow the installation instructions and manufacturer's use.
- e) The recommended size of the mattress to be used with the bed is 200cmx140cm, maximum thickness mattress:12cm.
- f) It is necessary to ventilate the room in order to maintain a low level moisture and prevent mold growth in the bed and its periphery.
- g) Joining devices should always be tightened properly and regularly verified. Tighten if necessary.

ANLEITUNGEN

WICHTIG - SORGFÄLTIG LESEN - FÜR SPÄTERE VERWENDUNG

AUFBEWAHREN

- a) **WARNUNG** - Kinder können zwischen dem Bett und der Wand, den angrenzenden Möbelstücken (z. B. Schränken) und der Lücke eingeklemmt werden. Um die Gefahr schwerer Verletzungen zu vermeiden, darf der Abstand zwischen der Sicherheitsbarriere und der angrenzenden Struktur nicht mehr als 75 mm oder mehr als 230 mm betragen.
- b) **WARNUNG**-Das Bett darf nicht benutzt werden, wenn ein Bauteil gebrochen ist oder fehlt; Ersatzteile sind beim Hersteller oder im Geschäft anzufordern.
- c) **WARNUNG** - Klettern oder wackeln Sie nicht auf nicht dafür vorgesehenen Strukturen.
- d) Befolgen Sie unbedingt die Installationsanweisungen und die Gebrauchsanweisungen des Herstellers.
- e) Die empfohlene Größe der Matratze für das Bett beträgt 200x140cm, maximale Dicke der Matratze: 12cm.
- f) Es ist notwendig, den Raum zu lüften, um die Feuchtigkeit niedrig zu halten und Schimmelbildung im Bett und seiner Umgebung zu verhindern.
- g) Die Verbindungselemente sollten immer richtig angezogen sein und regelmäßig überprüft werden. Ziehen Sie sie gegebenenfalls nach.

English

IMPORTANT ! KEEP FOR FUTURE REFERENCE : READ CAREFULLY

- To be assembled by an adult. Assembly must be checked by an adult before use
- WARNING ! Keep all screws, small parts and plastic bags out of the reach of children
- Properly identify all parts before assembling
- Never use your item if any of its parts are broken or missing
- Should any problems arise, please contact our After Sales Service
- Manufacturer's instructions shall be followed at all times
- Care: Clean with a soft, dry cloth. In case of larger stains, carefully rub with a slightly damp, non-abrasive sponge
- Avoid the risk of fire by not placing furniture near sources of ignition or hot items
- Do not jump on the bed

Deutsch

WICHTIG ! ZUM SPÄTEREN NACHSCHLAGEN AUFBEWAHREN: SORGFÄLTIG LESEN

- Muss von einem Erwachsenen zusammengebaut werden. Der Zusammenbau muss vor dem Gebrauch von einem Erwachsenen überprüft werden
- WARNUNG! Bewahren Sie alle Schrauben, Kleinteile und Plastikbeutel außerhalb der Reichweite von Kindern auf
- Kennzeichnen Sie vor dem Zusammenbau alle Teile richtig
- Benutzen Sie Ihren Artikel niemals, wenn Teile gebrochen sind oder fehlen
- Sollten Probleme auftreten, wenden Sie sich bitte an unseren Kundendienst
- Die Anweisungen des Herstellers sind stets zu befolgen
- Pflege: Mit einem weichen, trockenen Tuch reinigen. Bei größeren Flecken vorsichtig mit einem leicht feuchten, nicht scheuernden Schwamm abreiben. nicht scheuernden Schwamm
- Vermeiden Sie die Gefahr eines Brandes, indem Sie die Möbel nicht in der Nähe von Zündquellen oder heißen Gegenständen aufstellen
- Nicht auf das Bett springen

Français

IMPORTANT ! CONSERVER POUR RÉFÉRENCE ULTÉRIEURE : LIRE ATTENTIVEMENT

- Le montage doit être effectué par un adulte. Le montage doit être vérifié par un adulte avant Utilisation
- ATTENTION ! Tenir les vis, les petites pièces et les sachets en plastique hors de portée des enfants
- Identifiez correctement toutes les pièces avant de les assembler
- N'utilisez jamais votre article si l'une de ses pièces est cassée ou manquante
- En cas de problème, veuillez contacter notre service après-vente
- Les instructions du fabricant doivent être respectées à tout moment
- Entretien : nettoyer avec un chiffon doux et sec. En cas de taches plus importantes, frotter soigneusement avec une éponge non abrasive légèrement humide. légèrement humide et non Abrasive
- Évitez les risques d'incendie en ne plaçant pas les meubles à proximité de sources d'inflammation ou d'objets chauds
- Ne pas sauter sur le lit

Italiano

IMPORTANTE! CONSERVARE PER RIFERIMENTO FUTURO: LEGGERE ATTENTAMENTE

- Deve essere assemblato da un adulto. L'assemblaggio deve essere controllato da un adulto prima dell'uso
- **ATTENZIONE!** Tenere tutte le viti, le piccole parti e i sacchetti di plastica fuori dalla portata dei bambini
- Identificare correttamente tutte le parti prima dell'assemblaggio
- Non utilizzare mai l'articolo se alcune parti sono rotte o mancanti
- In caso di problemi, si prega di contattare il nostro Servizio Post Vendita
- Le istruzioni del produttore devono essere sempre seguite
- Cura: Pulire con un panno morbido e asciutto. In caso di macchie più estese, strofinare accuratamente con una spugna leggermente umida e nonspugna leggermente umida e non abrasiva
- Evitare il rischio di incendio, non collocando i mobili vicino a fonti di accensione o a oggetti caldi
- Non saltare sul letto

Español

¡ IMPORTANTE ! CONSERVELO PARA FUTURAS CONSULTAS: LEA ATENTAMENTE

- Debe ser montado por un adulto. El montaje debe ser comprobado por un adulto antes del uso
- ADVERTENCIA Mantenga todos los tornillos, piezas pequeñas y bolsas de plástico fuera del alcance de los niños.
- Identifique correctamente todas las piezas antes de montarlas
 - Nunca utilice su artículo si alguna de sus piezas está rota o falta
 - Si surge algún problema, póngase en contacto con nuestro Servicio Postventa
 - Las instrucciones del fabricante deben seguirse en todo momento
 - Cuidado: Limpiar con un paño suave y seco. En caso de manchas más grandes, frote cuidadosamente con una esponja no abrasiva ligeramente humedecida.
 - Evite el riesgo de incendio no colocando los muebles cerca de fuentes de ignición u objetos calientes.
 - No saltar sobre la cama.

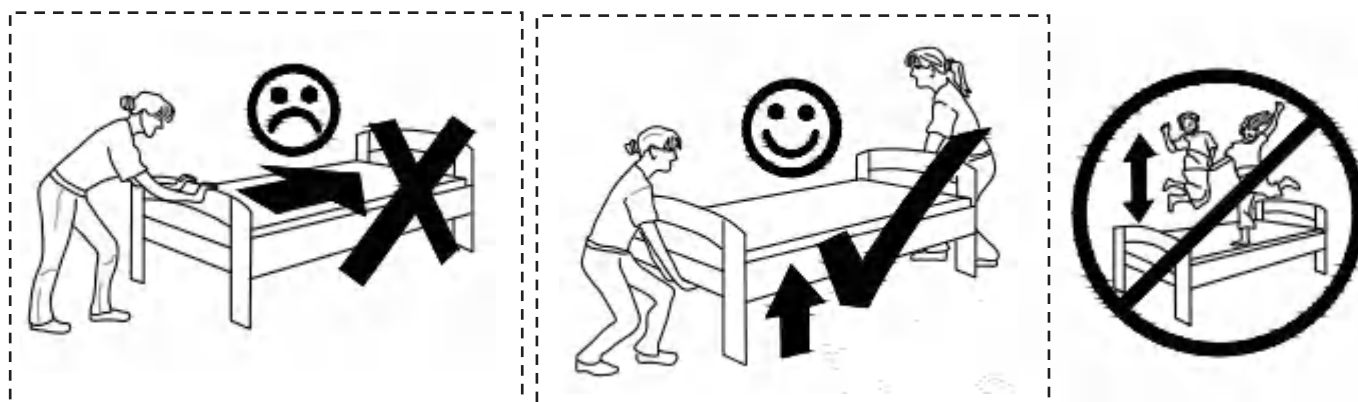

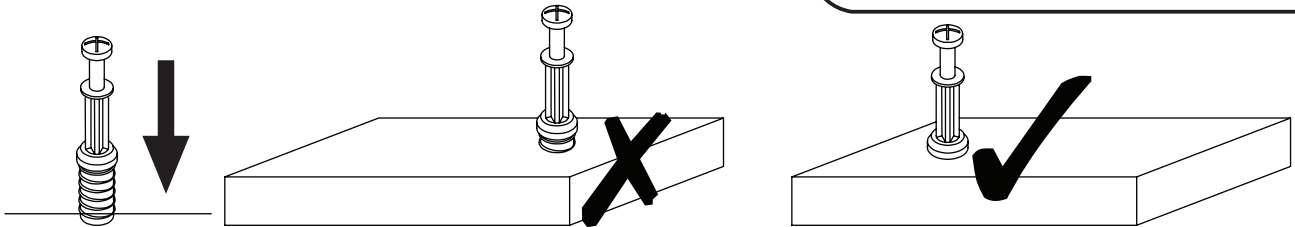

EN_QUICKFIT: Tighten quickfit until shoulder is flush with panel. Do not overtighten or undertighten.

FR_RACCORD RAPIDE: Faites serrer le raccord rapide jusqu'à ce que l'épaule soit parfaitement encastré dans le panneau. Il ne faut ni trop serrer ni insuffisamment serrer.

ES_QUICKFIT: Apriete quickfit hasta que el hombro se descargue con el panel. NO lo sobreapriete ni lo apriete poco.

DE_QUICKFIT: Ziehen Sie den Quickfit fest, bis die Schulter mit der Platte bündig ist. Bitte nicht zu fest oder zu schwach anziehen.

IT_MONTAGGIO RAPIDO: Stringere il montaggio rapido fino a quando la spalla è a filo con il pannello, non stringere troppo o troppo poco.

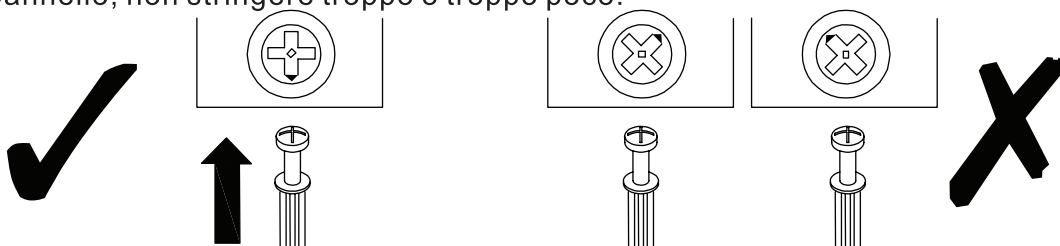

EN_CAM LOCK: When fitting cam lock, ensure starting position is correct before you insert connecting quickfit.

FR_SERRURE BATTEUSE: Avant d'insérer la serrure batteuse, veillez à la bonne orientation avant d'insérer le raccord rapide.

ES_CIERRE DE LA CÁMARA: Cuando instale el cierre de la cámara, asegúrese de que la posición de inicio es correcta antes de que inserte el quickfit conector.

DE_CAM-LOCK: Achten Sie bei der Montage des Cam-Locks auf die richtige Ausgangsposition, bevor Sie den Quickfit einsetzen.

IT_BLOCCAGGIO A CAMMA: Quando si monta il bloccaggio a camma, assicurarsi che la posizione iniziale sia corretta prima di inserire il montaggio rapido di collegamento.

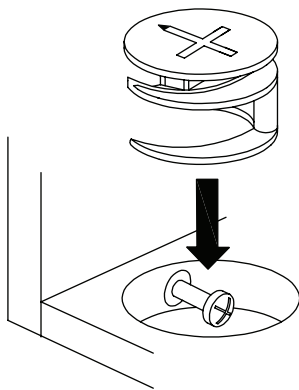

EN_Quickfit head should be in the centre of the cam lock when the two panels are joined.

Cam lock should be inserted before quickfit.

FR_Lorsque les deux panneaux sont assemblés, la tête du raccord rapide doit reposer au centre de la serrure batteuse. Il faut insérer la serrure batteuse avant le raccord rapide.

ES_El cabezal del quickfit debe estar en el centro del cierre de la cámara cuando se unan los dos paneles.

Se debe insertar el cierre de la cámara antes que el quickfit.

DE_Der Quickfit-Kopf sollte sich in der Mitte des Cam-Locks befinden, wenn die beiden Platten zusammengefügt sind.

Der Cam-Lock sollte vor dem Quickfit eingesetzt werden.

IT_La testa del montaggio rapido deve trovarsi al centro del bloccaggio a camma quando i due pannelli sono uniti.

Il Bloccaggio a Camma deve essere inserito prima del montaggio rapido.

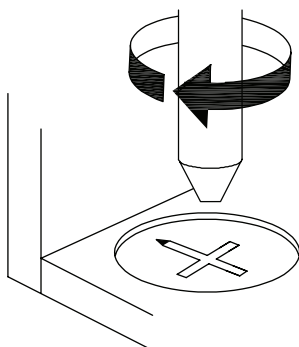

EN_Turn cam lock clockwise to tighten.

FR_Faites tourner la serrure batteuse dans le sens des aiguilles d'une montre pour la resserrer.

ES_Gire el cierre de la cámara en sentido horario para apretarlo.

DE_Drehen Sie den Cam-Lock im Uhrzeigersinn, um ihn festzuziehen.

IT_Ruotare il bloccaggio a camma in senso orario per stringere.

DE: Vor dem Einbau die Schrauben in die Löcher stecken und festziehen, aber nicht bis 100%, 70% bis 80% anziehen reicht aus. Schließlich, nachdem alle Schrauben installiert sind, ziehen Sie alle Schrauben auf 100%. Wenn Sie auf diese Probleme stoßen, wie z. B. Fehlausrichtung der Löcher oder Unfähigkeit, bestimmte Teile zu installieren, überprüfen Sie bitte, ob die Schrauben korrekt verwendet werden und passen Sie die Dichtigkeit der Schrauben an.

UK: Before installation, insert the screws into the holes and tighten them, but do not tighten them to 100%, 70% to 80% is sufficient. Finally, after all screws are installed, tighten all screws to 100%. If you encounter these issues, such as if the holes cannot be aligned or some parts cannot be installed, please check if the screws are used correctly and adjust the tightness of the screws.

FR: Insérer la vis dans le trou avant la fin de l'assemblage, serrer la vis, mais ne pas serrer à 100%, 70% ~ 80% est correct. Enfin, une fois que toutes les vis sont bien serrées, toutes les vis sont serrées à 100%. Si vous rencontrez ces problèmes, par exemple si les trous ne sont pas alignés ou si certaines pièces ne peuvent pas être montées, vérifiez que les vis sont utilisées correctement et Ajustez leur serrage.



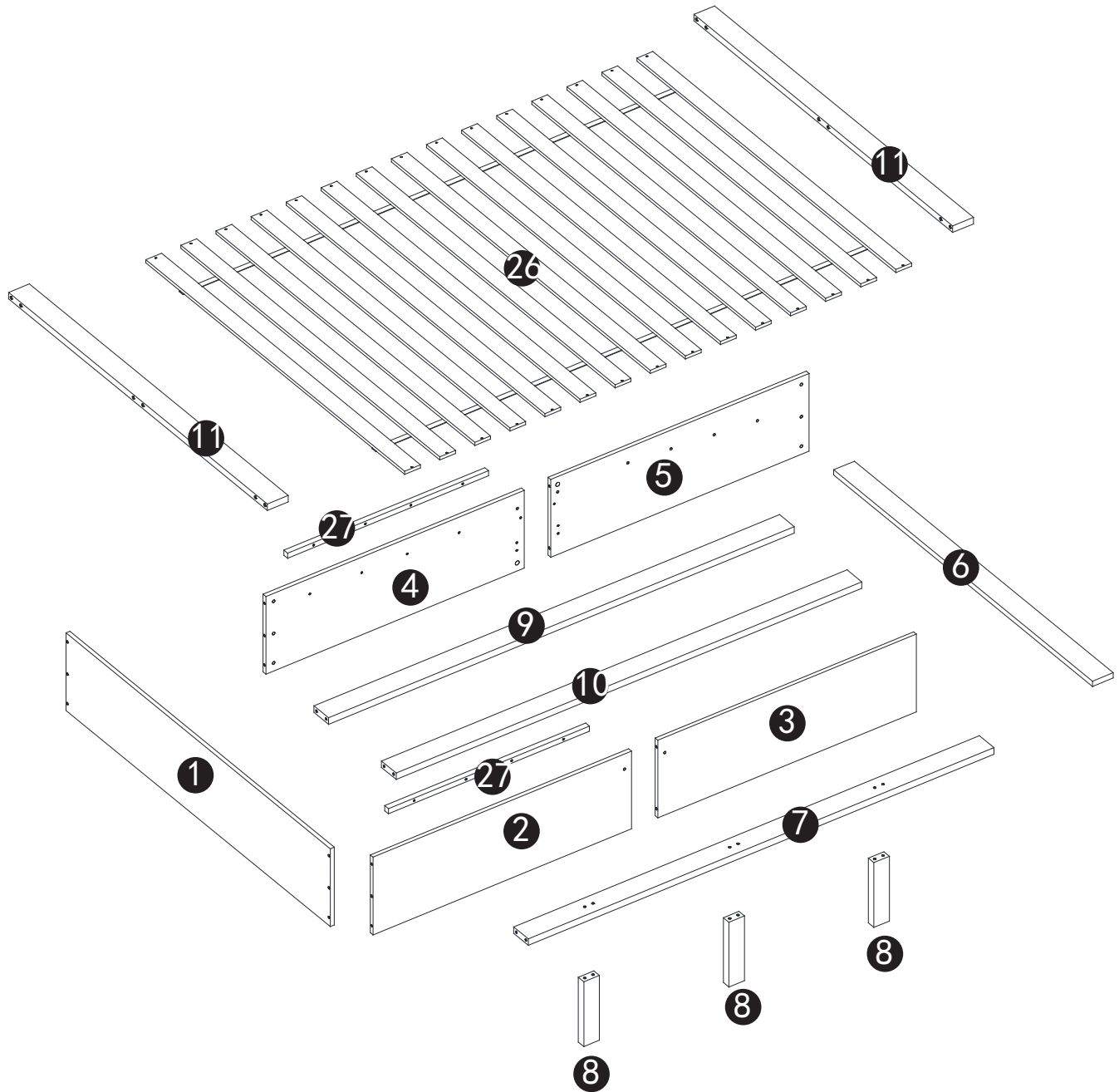

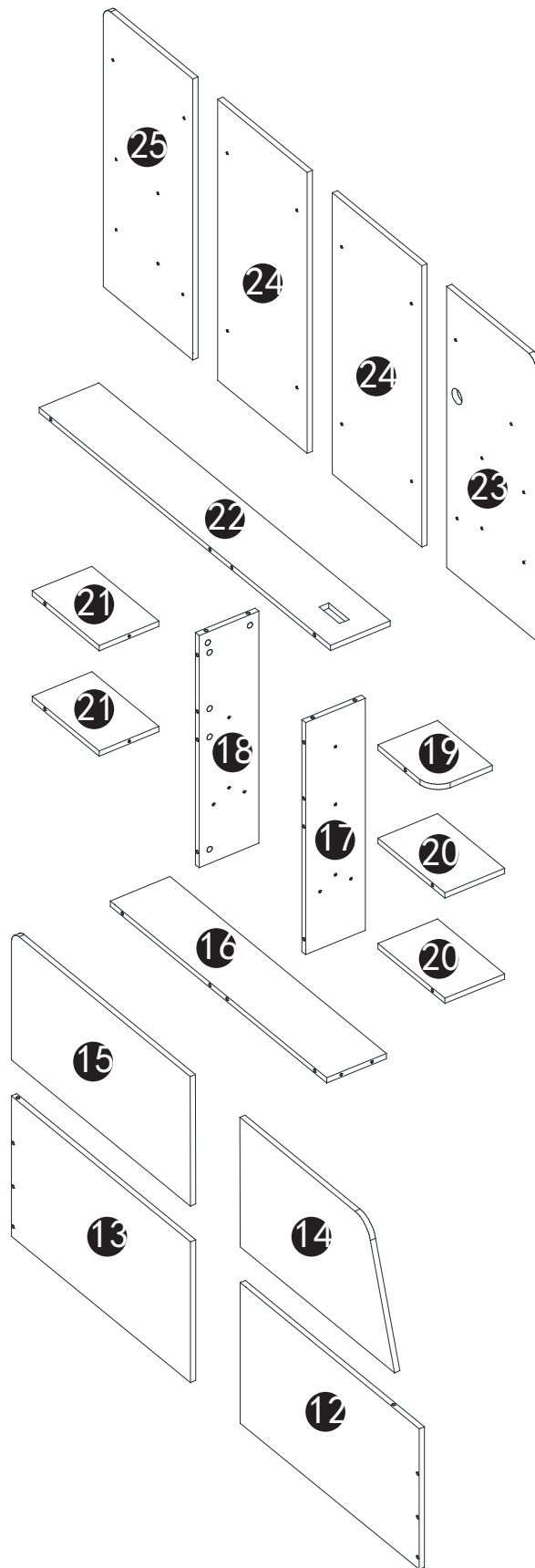

Detailansicht 1/2



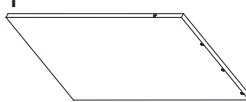

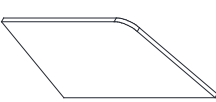

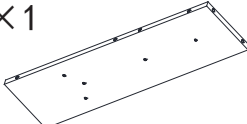
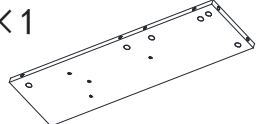
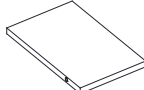
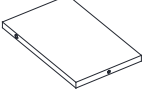

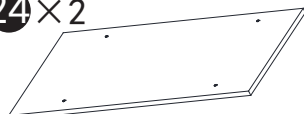
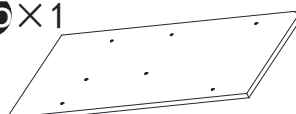
Detailansicht2/2



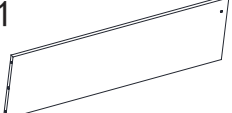

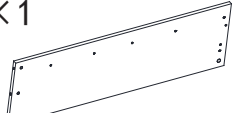
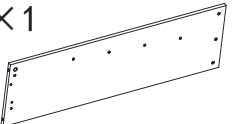
N636P379689

12 ×1 	13 ×1 	14 ×1 	15 ×1 
17 ×1 	18 ×1 	20 ×2 	21 ×2 
23 ×1 	24 ×2 	25 ×1 	





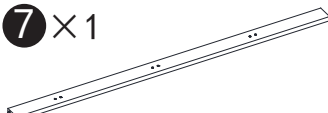

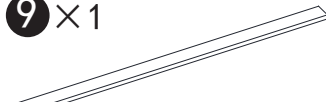
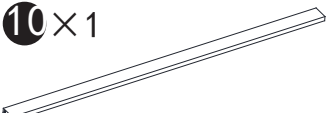
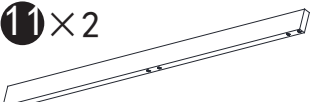
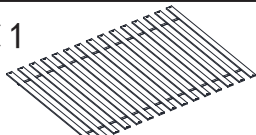
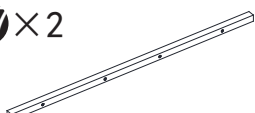









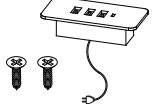
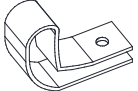
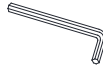
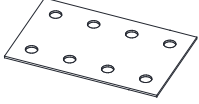

N636P379690

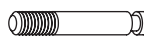
1 ×1 	2 ×1 	3 ×1 	4 ×1 
5 ×1 	16 ×1 	19 ×1 	22 ×1 

N636P379691

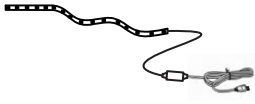

6 ×1 	7 ×1 	8 ×3 	9 ×1 
10 ×1 	11 ×2 	26 ×1 	27 ×2 

N636P379691

A  M6*90mm(12PCS)	B  M6*60mm(12PCS)	C  M6*20mm(14PCS)	D  x8 (1PCS)
E  (24PCS)	F  Φ3.5*30mm(38PCS)	G  Φ8*40mm(2PCS)	H  Φ3.5*14mm(33PCS)
I  (1PC)	J  (1PC)	K  M3(1PC)	L  (3PCS)
M  Φ6*60mm(4PCS)	N  (2PCS)	O  (32PCS)	P  (32PCS)
Q  (1PC)	R  M4(1PC)	S  Φ7*50mm(6PCS)	T  Φ5*40mm(31PCS)
U  (1PC)	V  120cm(1PC)	W  (8PCS)	

VERWENDEN SIE KEINE POWER TOOLS, um dieses Produkt zusammenzubauen!



Do not use power tools to assemble this product!

A		B	
M6*90mm		M6*60mm	

DE:Bitte beachten Sie, dass die Formen der Schrauben A und B ähnlich sind. Bitte installieren Sie entsprechend der Anleitung und unterscheiden Sie sie!

UK:Please note that the shapes of screws A and B are similar. Please install according to the instructions and distinguish them!

FR:Notez que les vis A et B ont des formes similaires. Veuillez les installer en suivant les instructions pour les séparer!



F		H	
Φ4*30mm		Φ3.5*14mm	

DE:Bitte beachten Sie, dass die Formen der Schrauben F und H ähnlich sind. Bitte installieren Sie entsprechend der Anleitung und unterscheiden Sie sie!

UK:Please note that the shapes of screws F and H are similar. Please install according to the instructions and distinguish them!



FR:Notez que les vis F et H ont des formes similaires. Veuillez les installer en suivant les instructions pour les séparer!

01

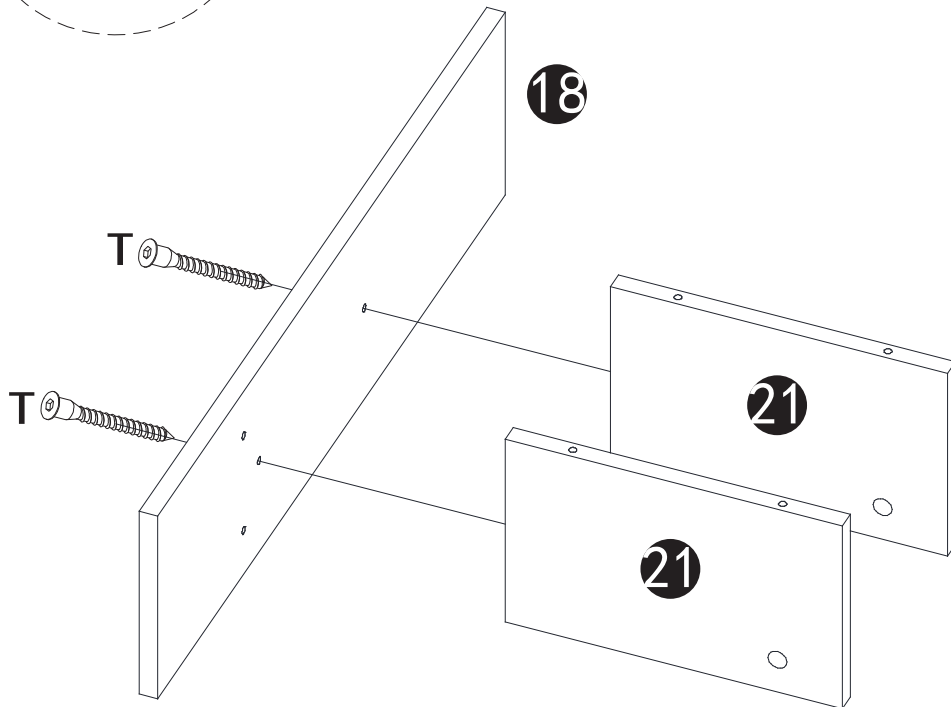
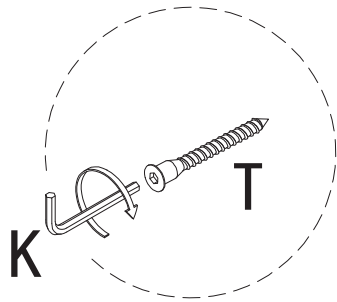
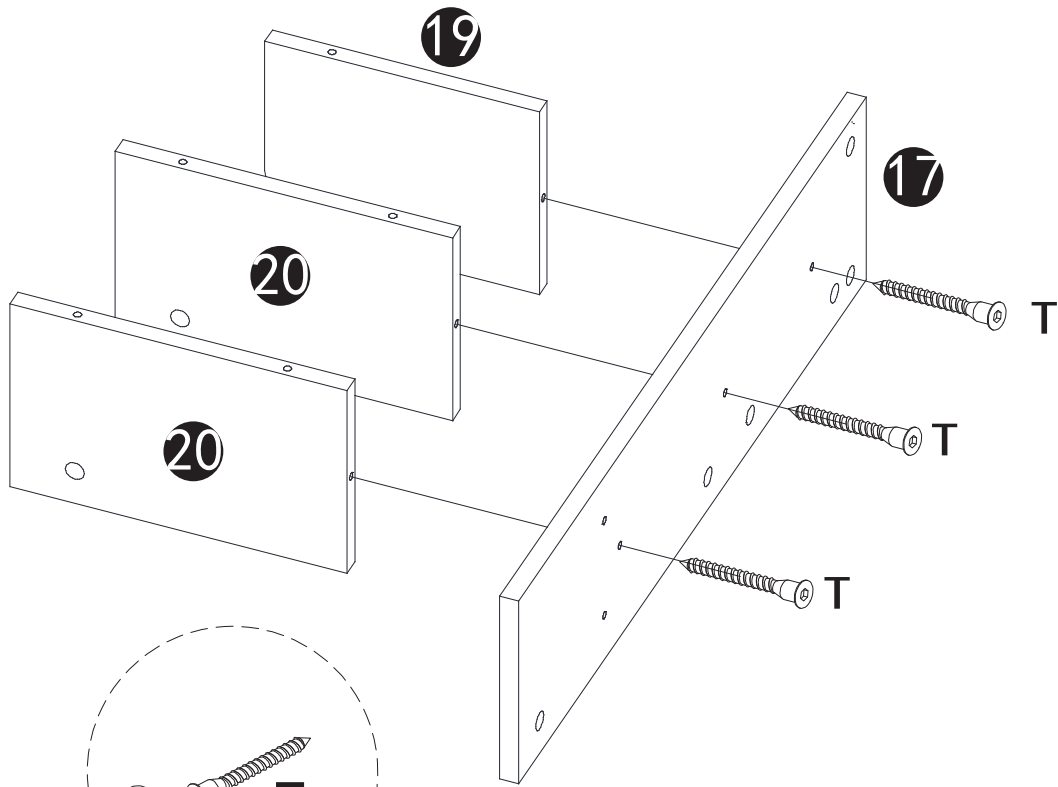
T	K
	
5PCS	1PC



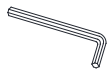

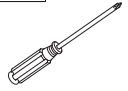

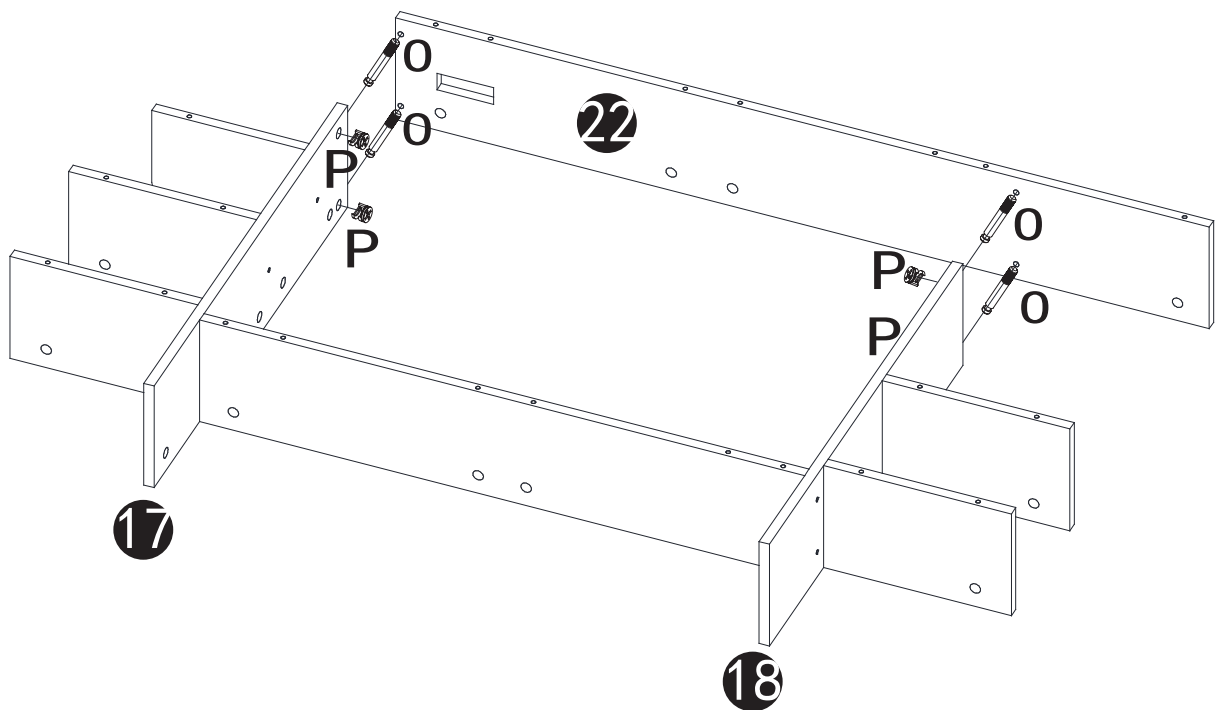
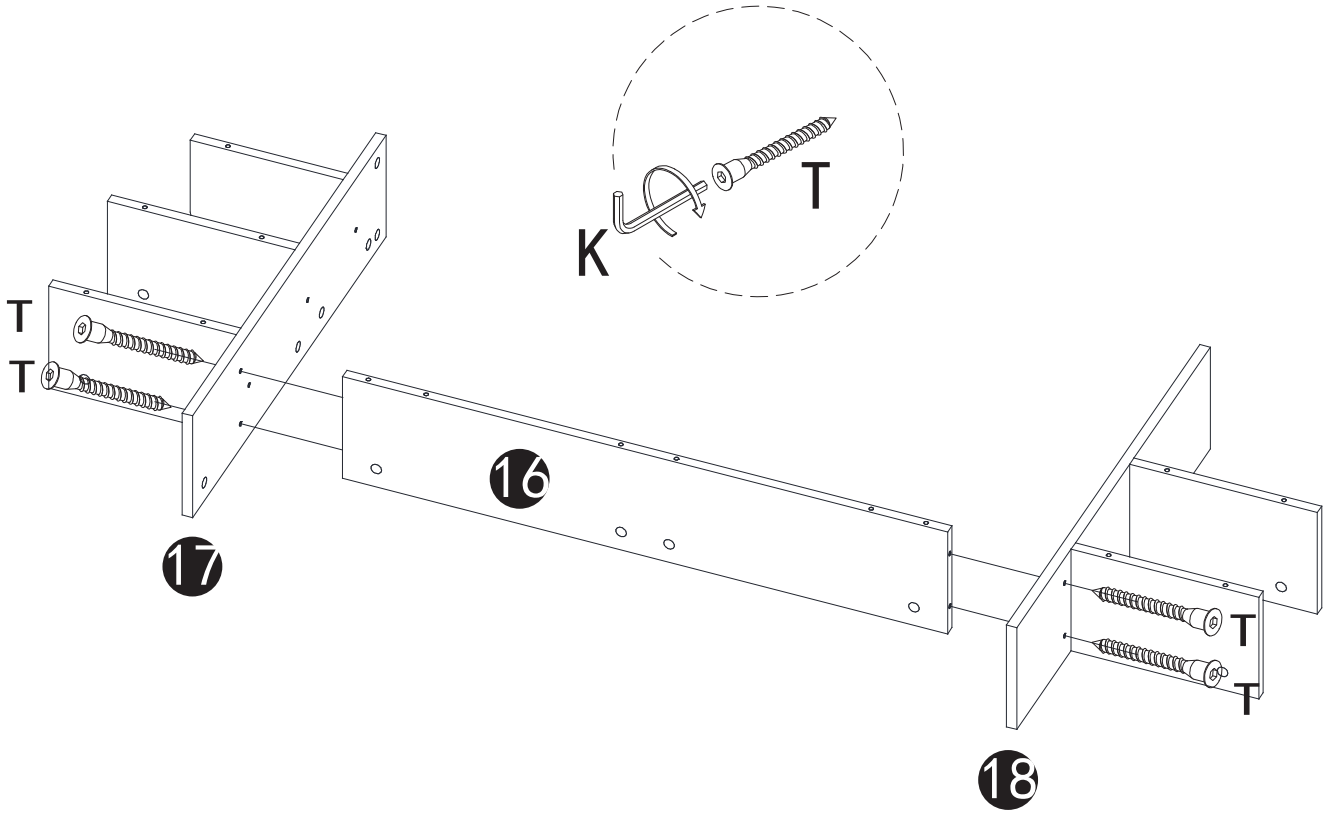
02

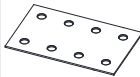

T	K	P	O	Q
				
4PCS	1PC	4PCS	4PCS	1PC

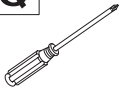

03

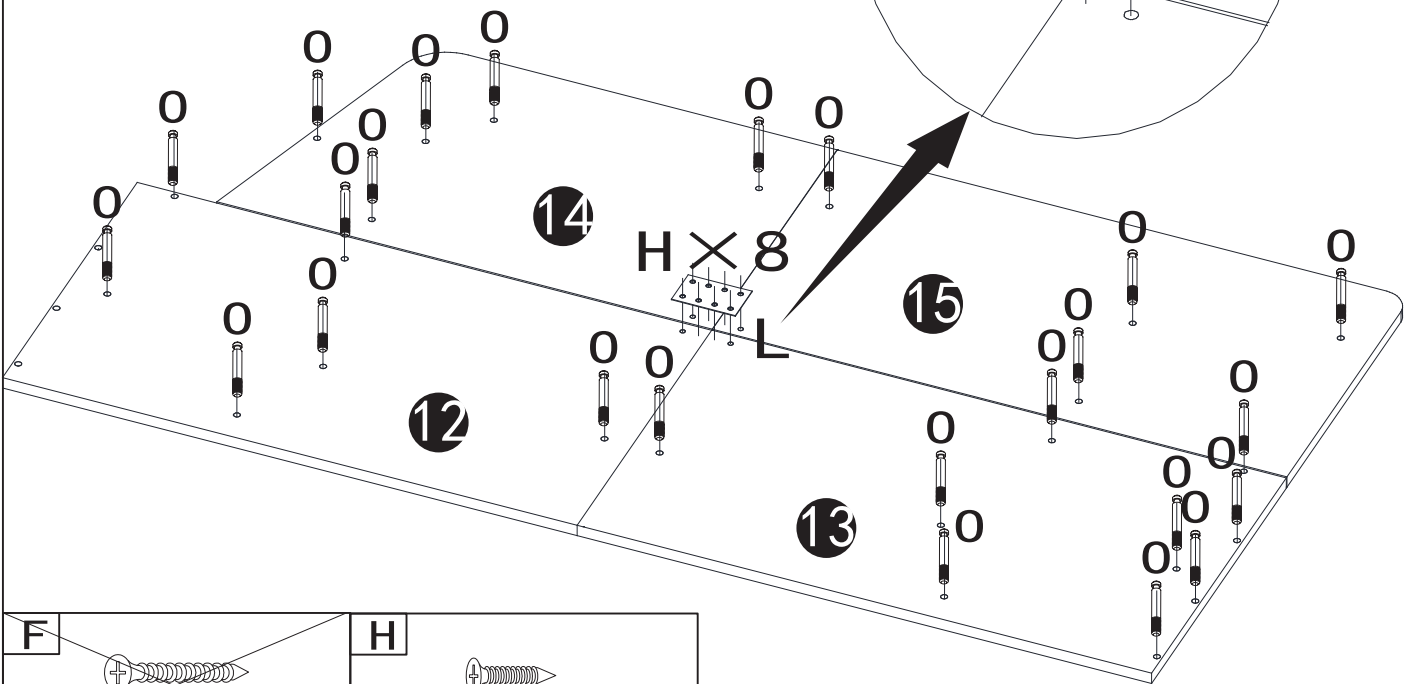
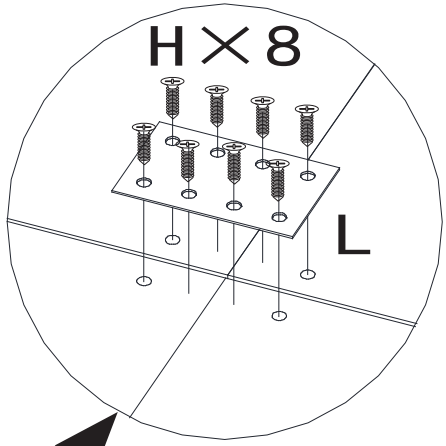
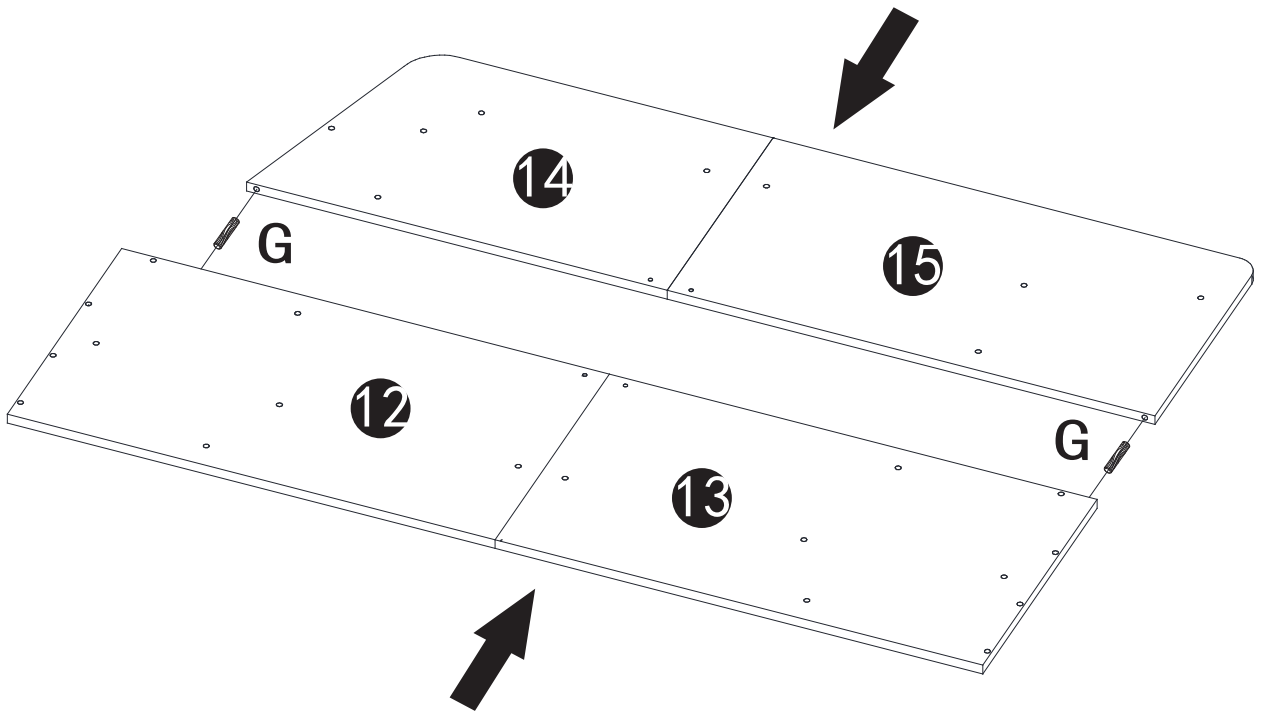
O 	L 	H 	Q 	G 
24PCS	1PC	8PCS	1PC	2PCS

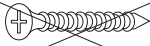

F 	H 
$\Phi 4 * 30\text{mm}$	$\Phi 3.5 * 14\text{mm} (8\text{PCS})$

04

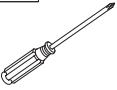
P	Q
	
24PCS	1PC

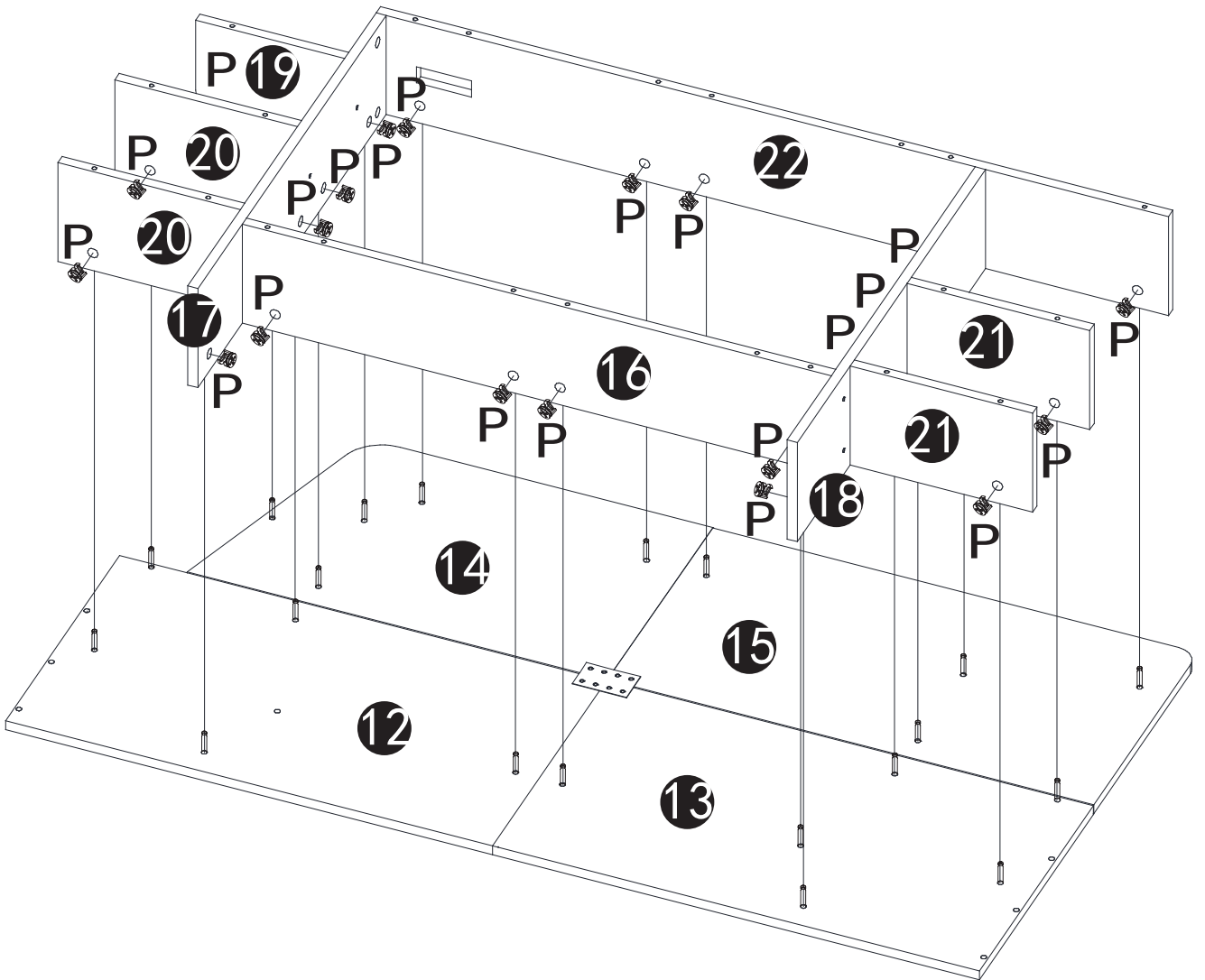

05

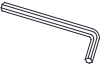
T	K
	
22PCS	1PC

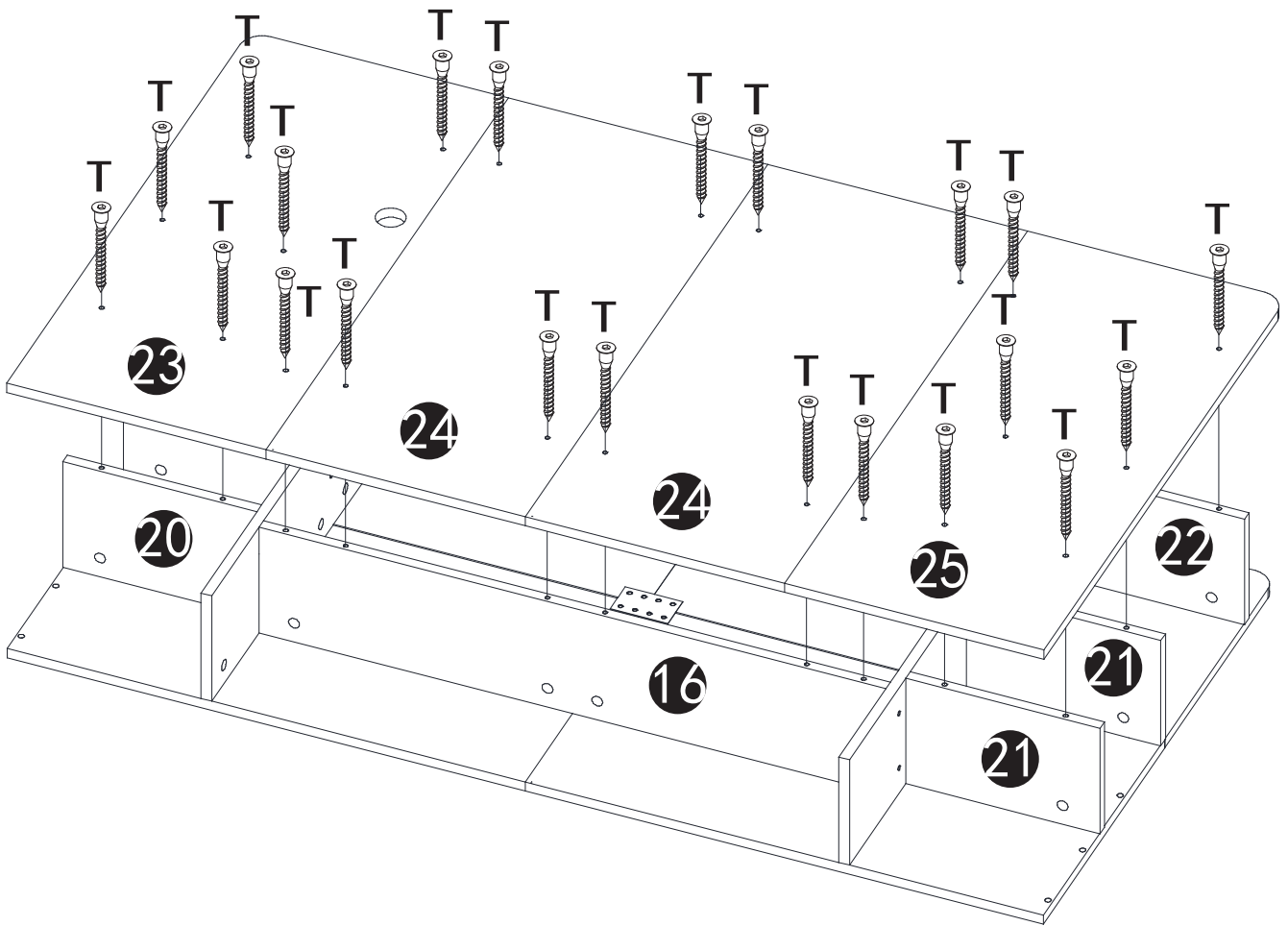
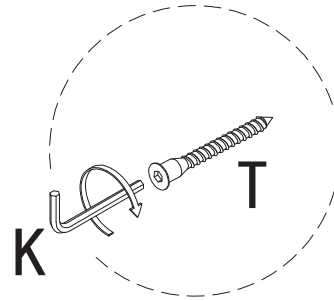

06

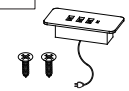
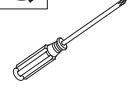
I	Q
	
1PC	1PC

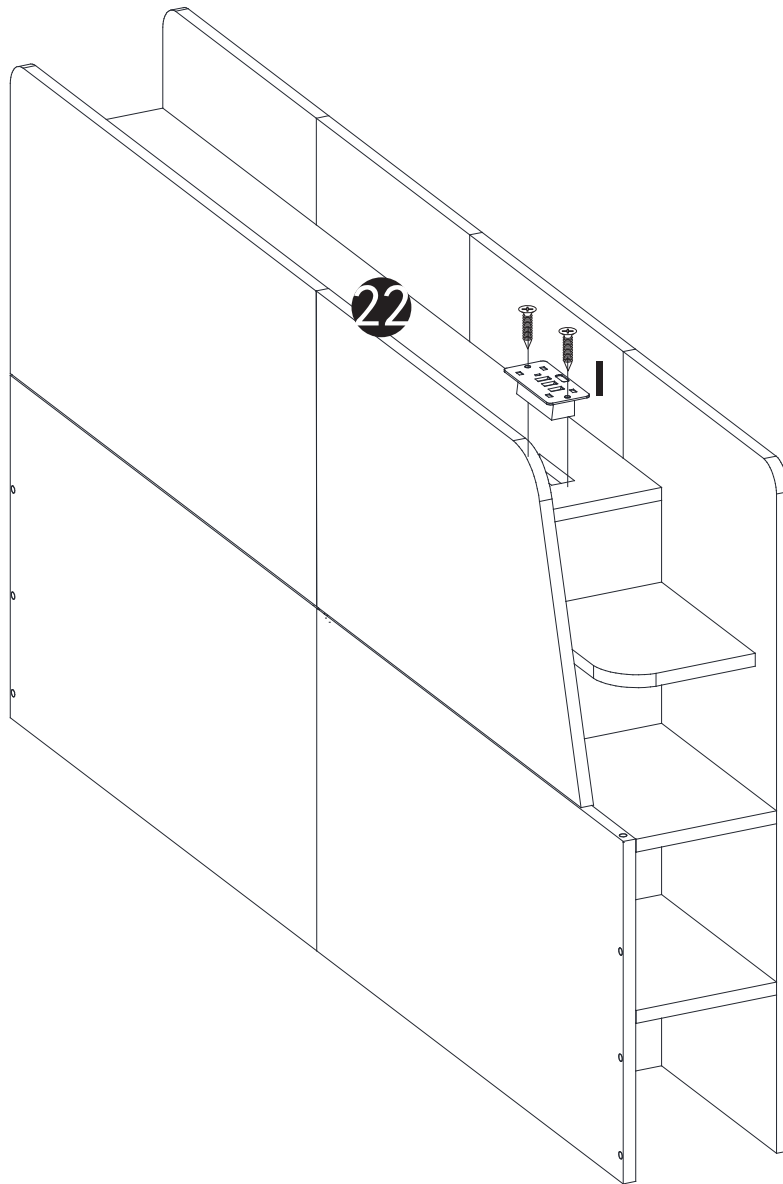
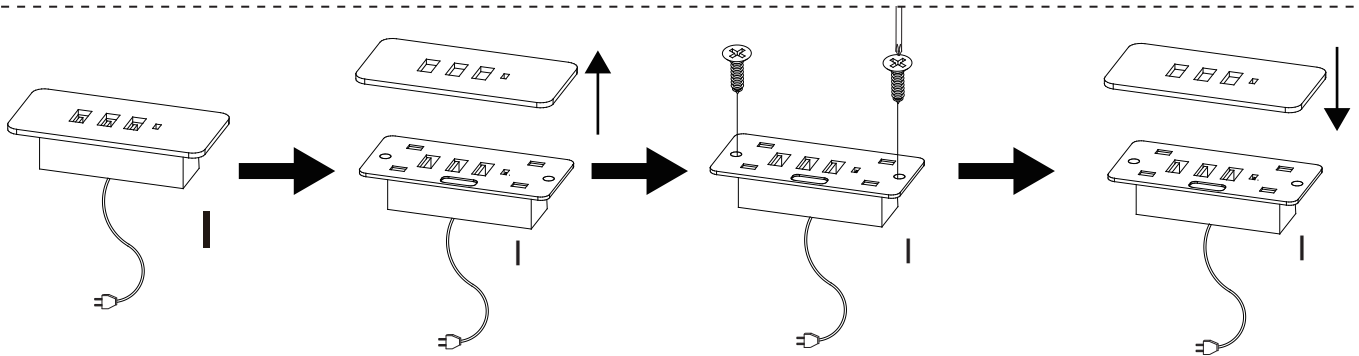

07

V



1PC

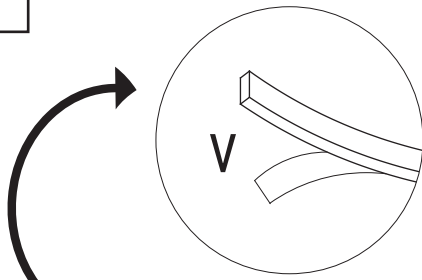

EN:Tear off the back tape
DE:Das Klebeband auf der Rückseite abziehen
FR:Retirez le ruban adhésif arrière
ES:Ouitar la cinta trasera
IT:Strappare il nastro posteriore

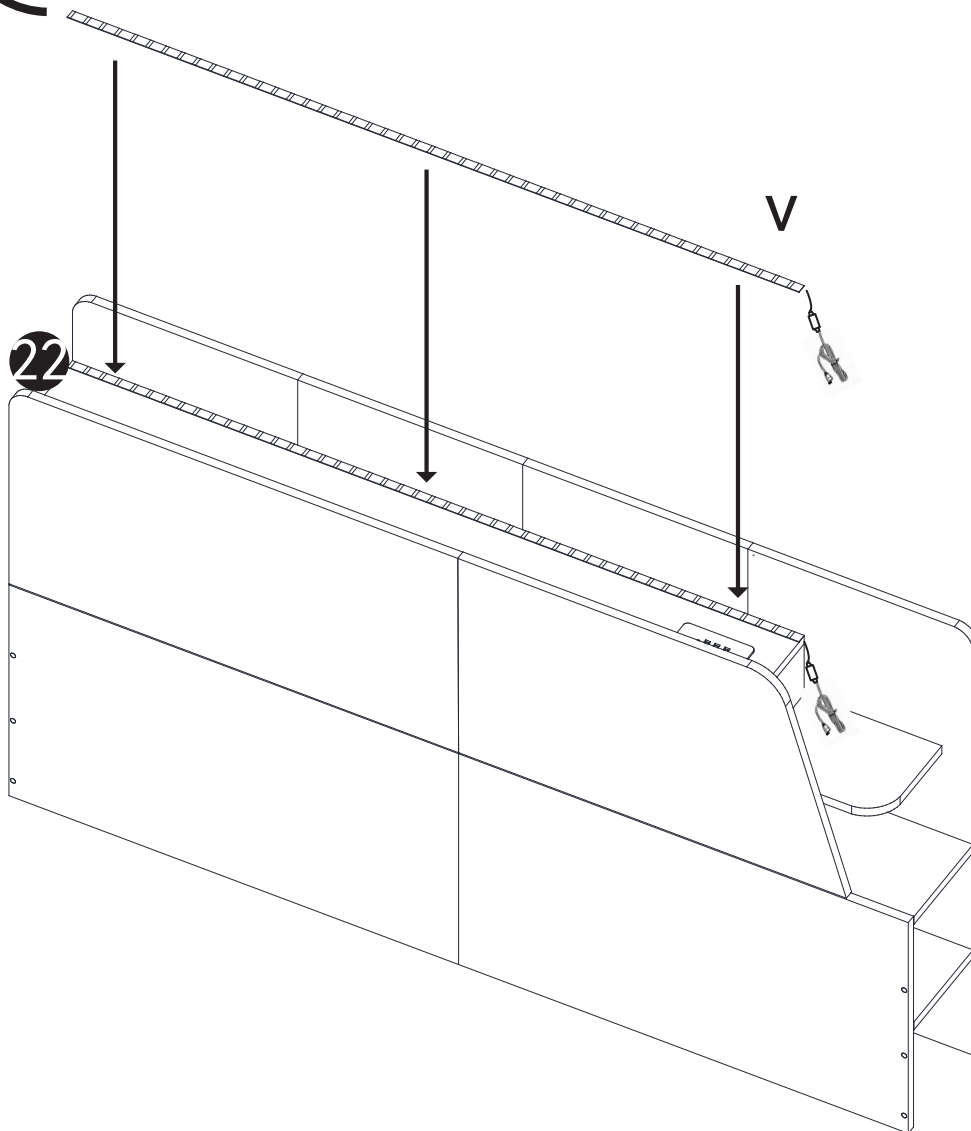



EN:Scan to download App control the Led light.

DE:Scannen, um die App zum Steuern des LED-Lichts herunterzuladen

FR:Scanner pour télécharger App contrôler la lumière Led.

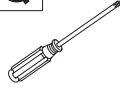
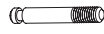

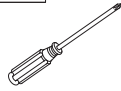
08

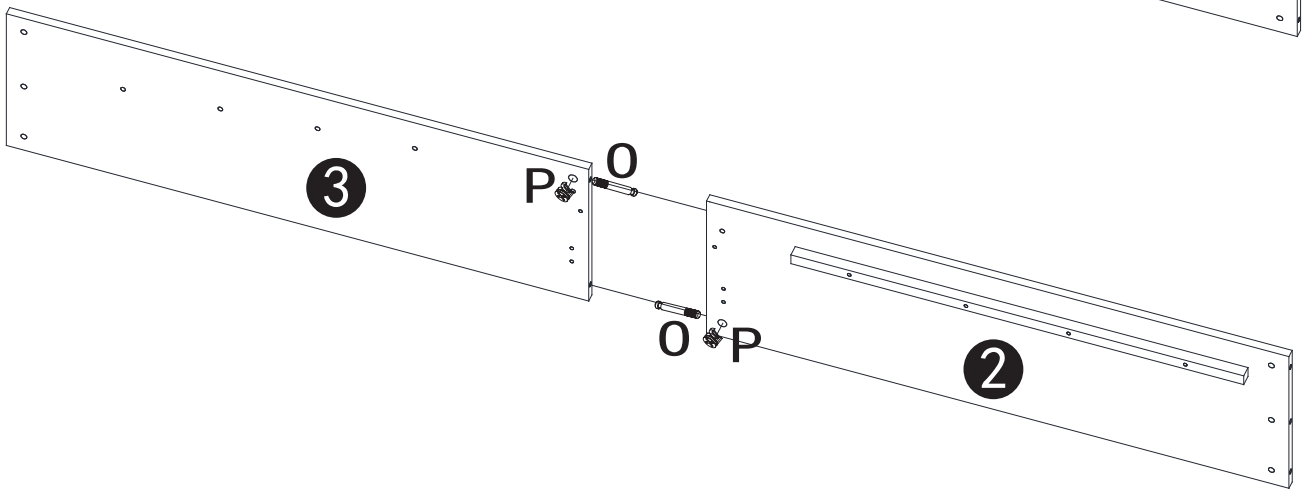
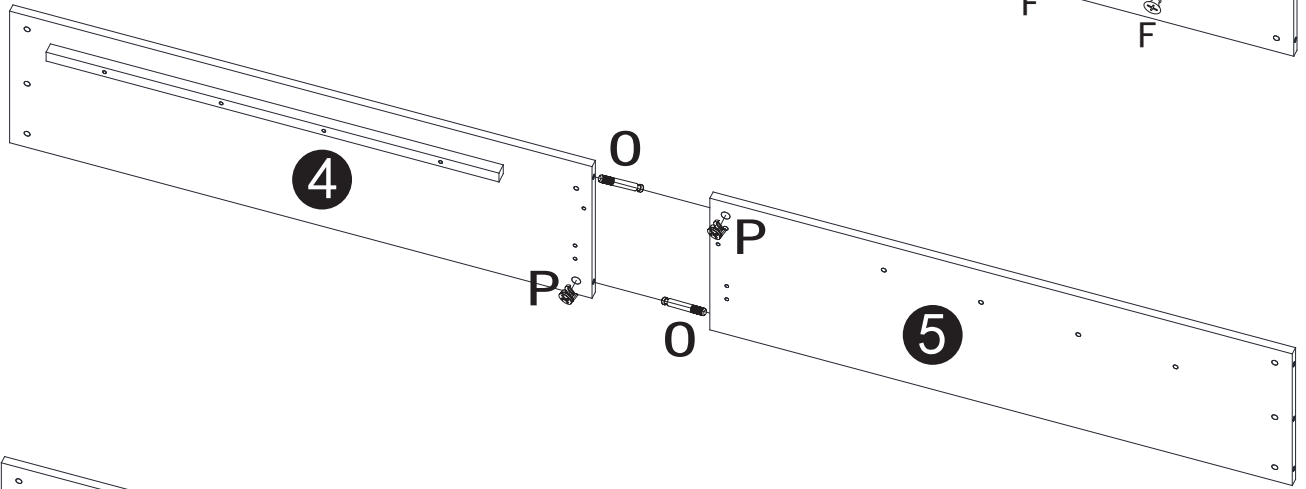
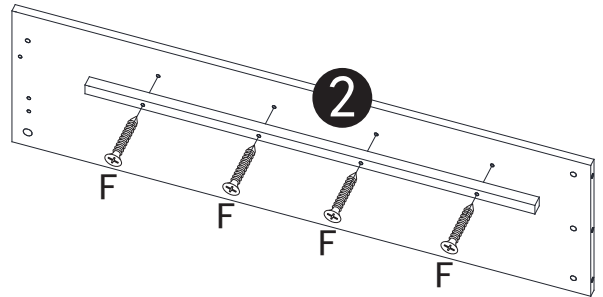
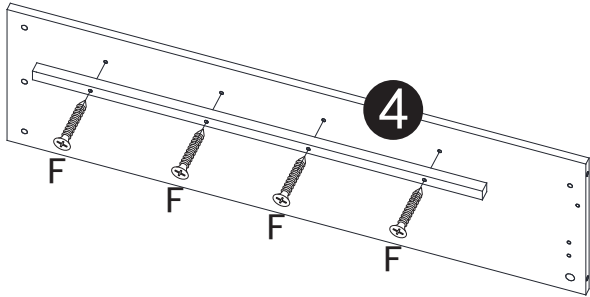
F 	Q 	O 	P 	Q 
8PCS	1PC	4PCS	4PCS	1PC

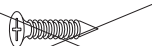



F 	H 
$\Phi 4 \times 30\text{mm}$ (8PCS)	$\Phi 3.5 \times 14\text{mm}$

09

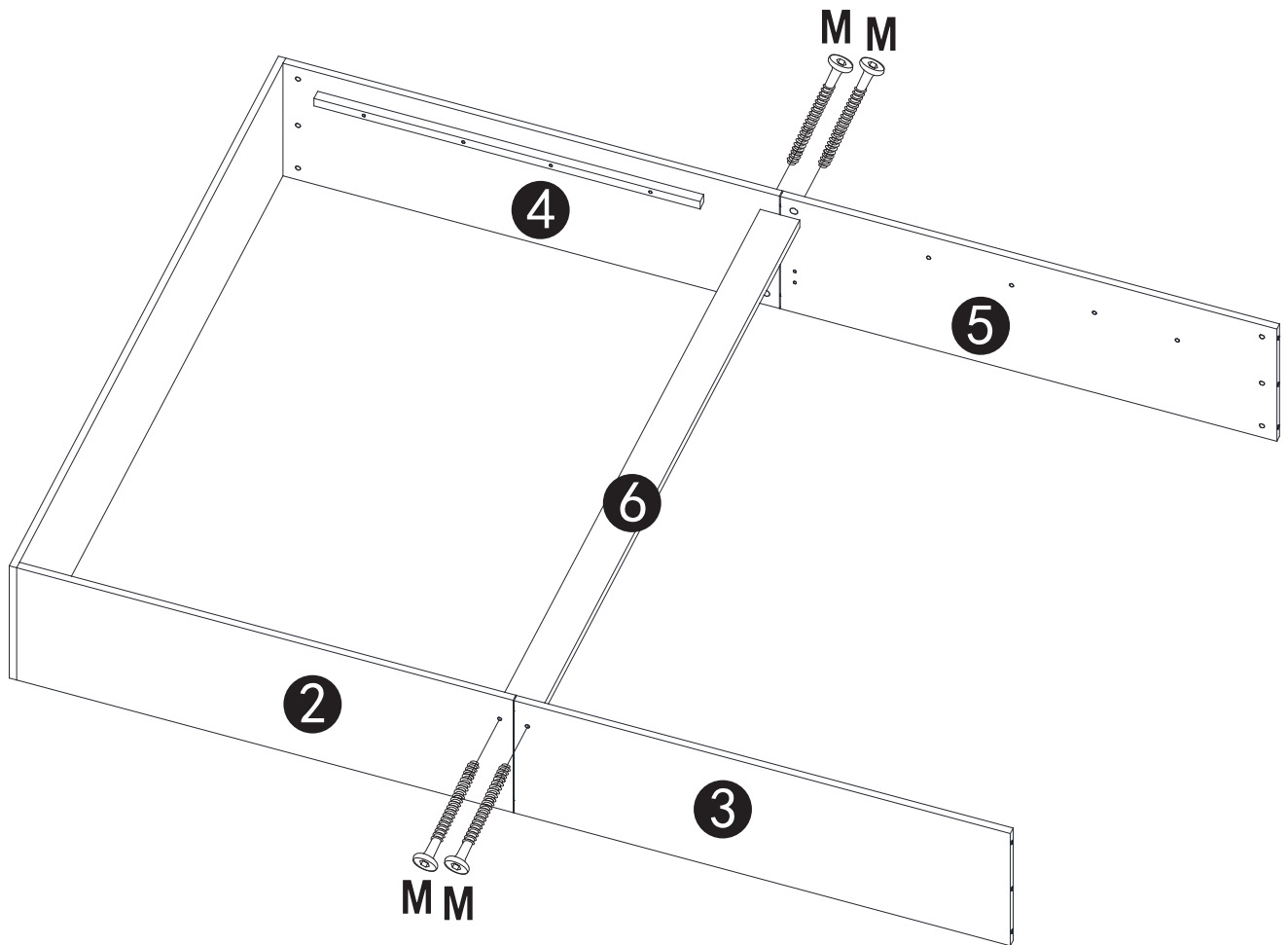
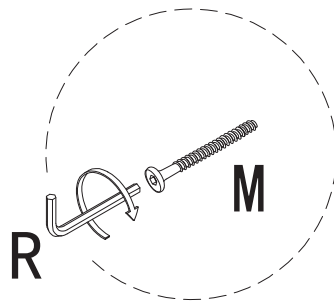

R	M
	
1PC	4PCS

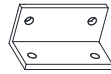

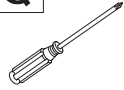
10

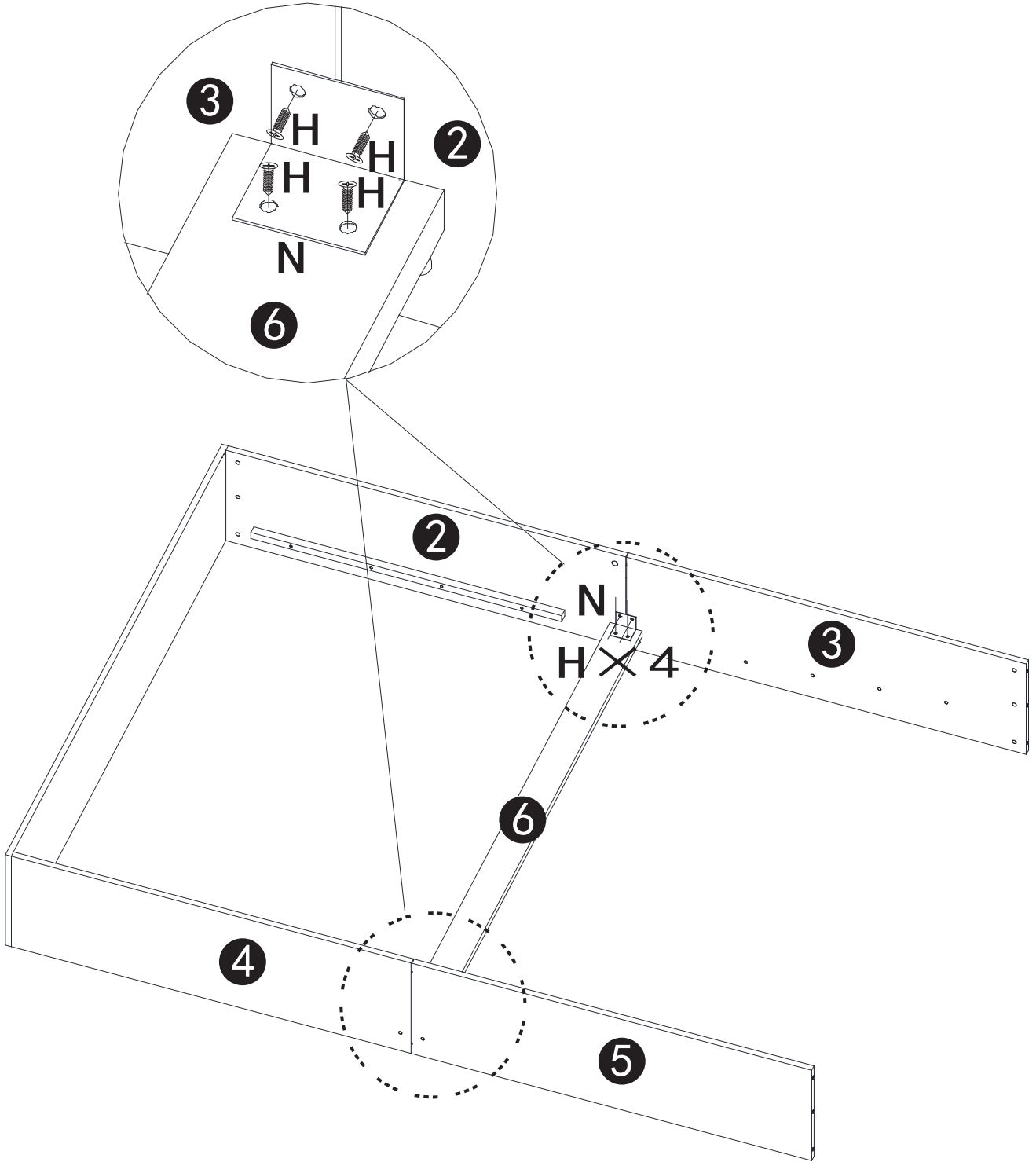
N	H	Q
		
2PCS	8PCS	1PC





F	H
	
Φ4*30mm	Φ3.5*14mm(8PCS)

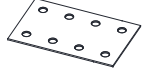
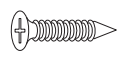
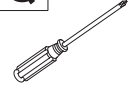

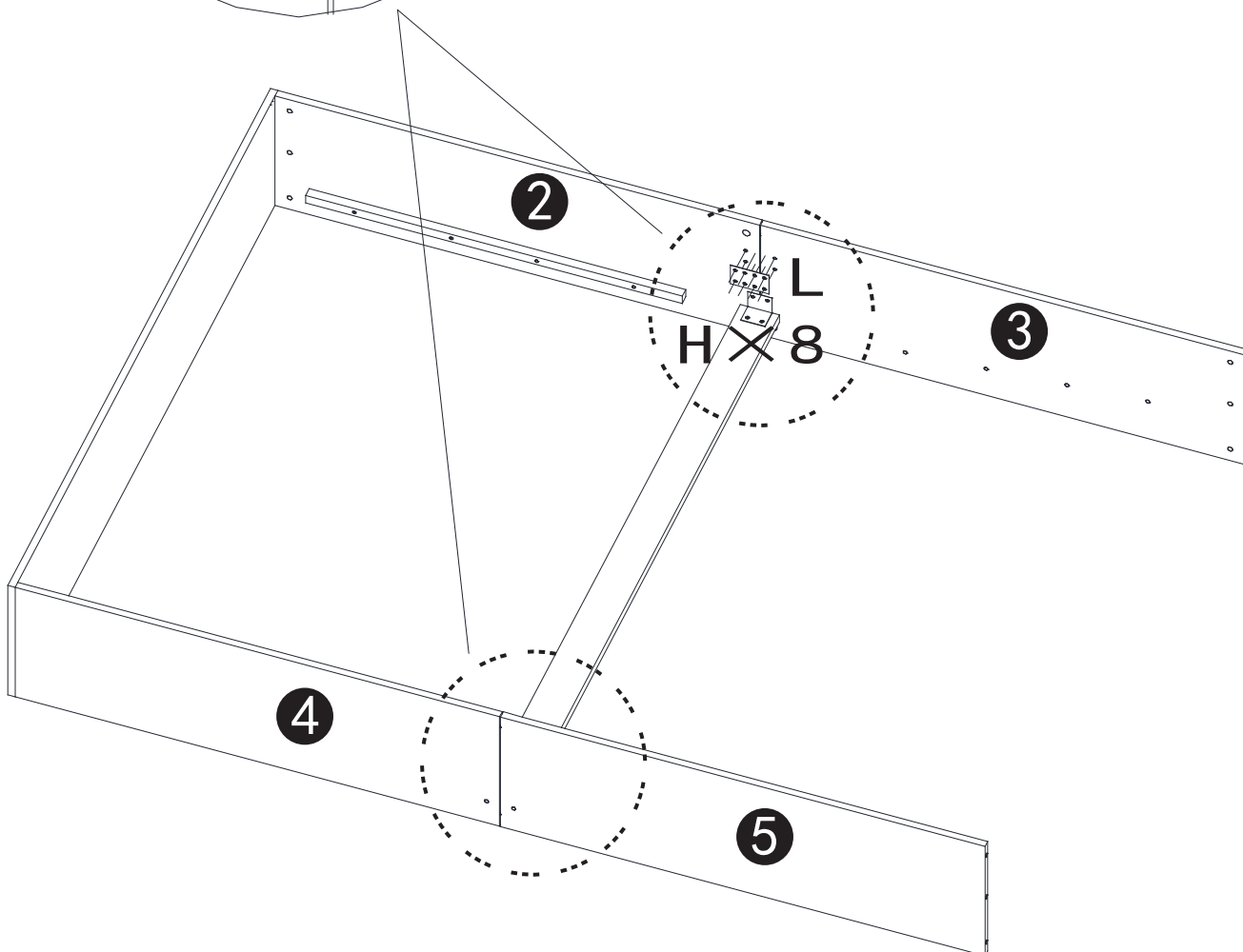
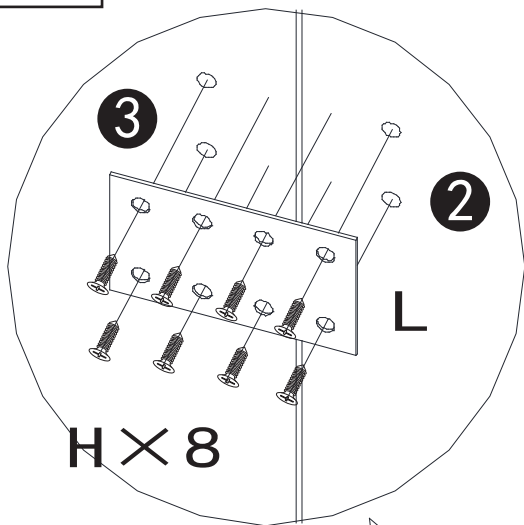
11

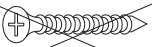
L 	H 	Q 
2PCS	16PCS	1PC





F 	H 
Φ4*30mm	Φ3.5*14mm(16PCS)

12

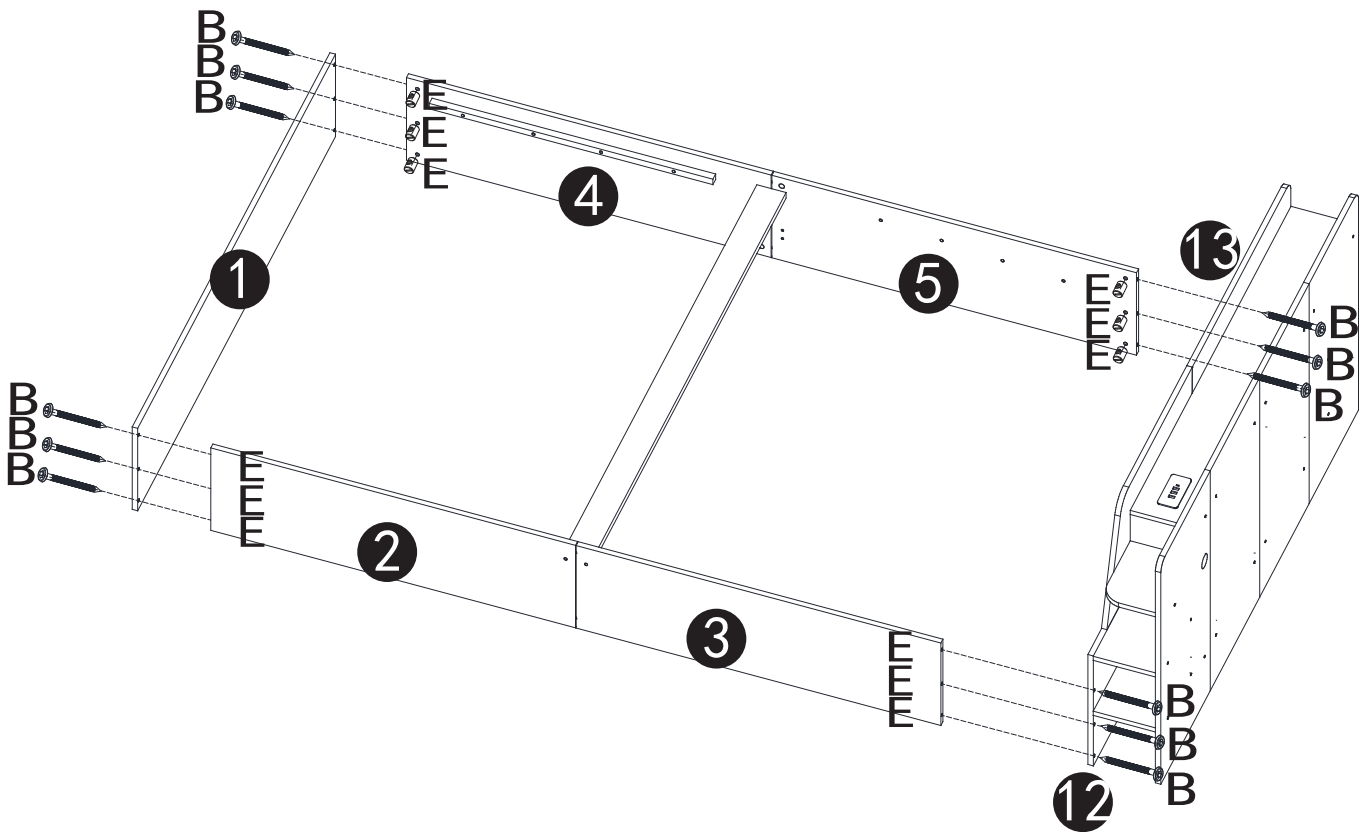
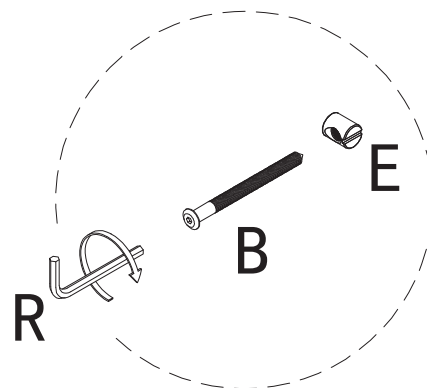
R	E	B
		
1PC	12PCS	12PCS





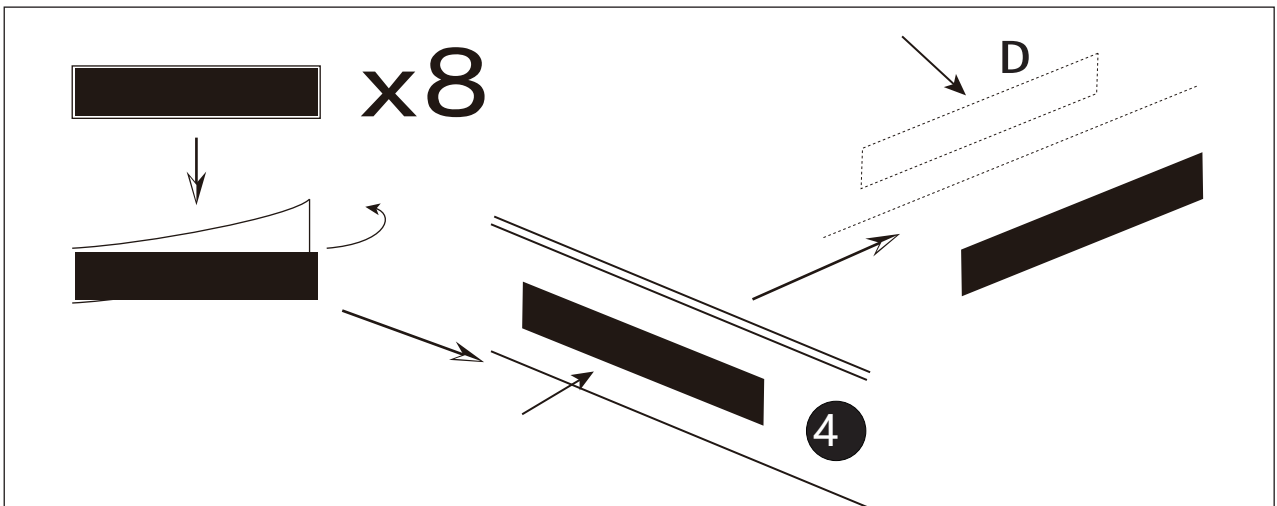
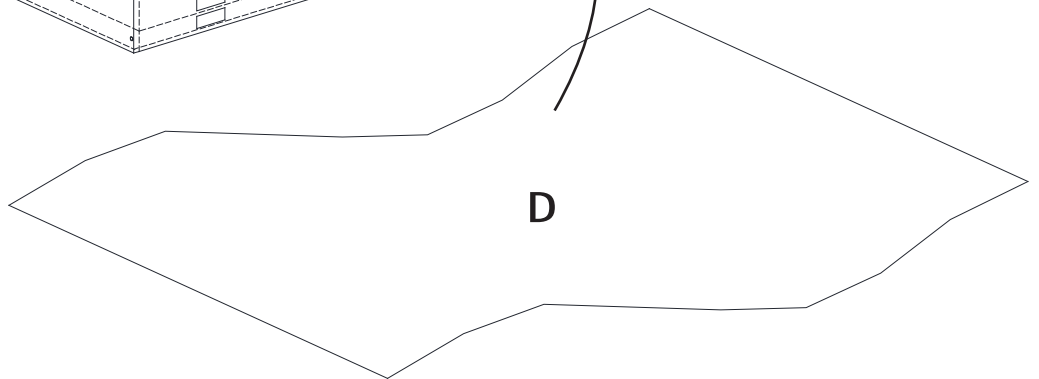
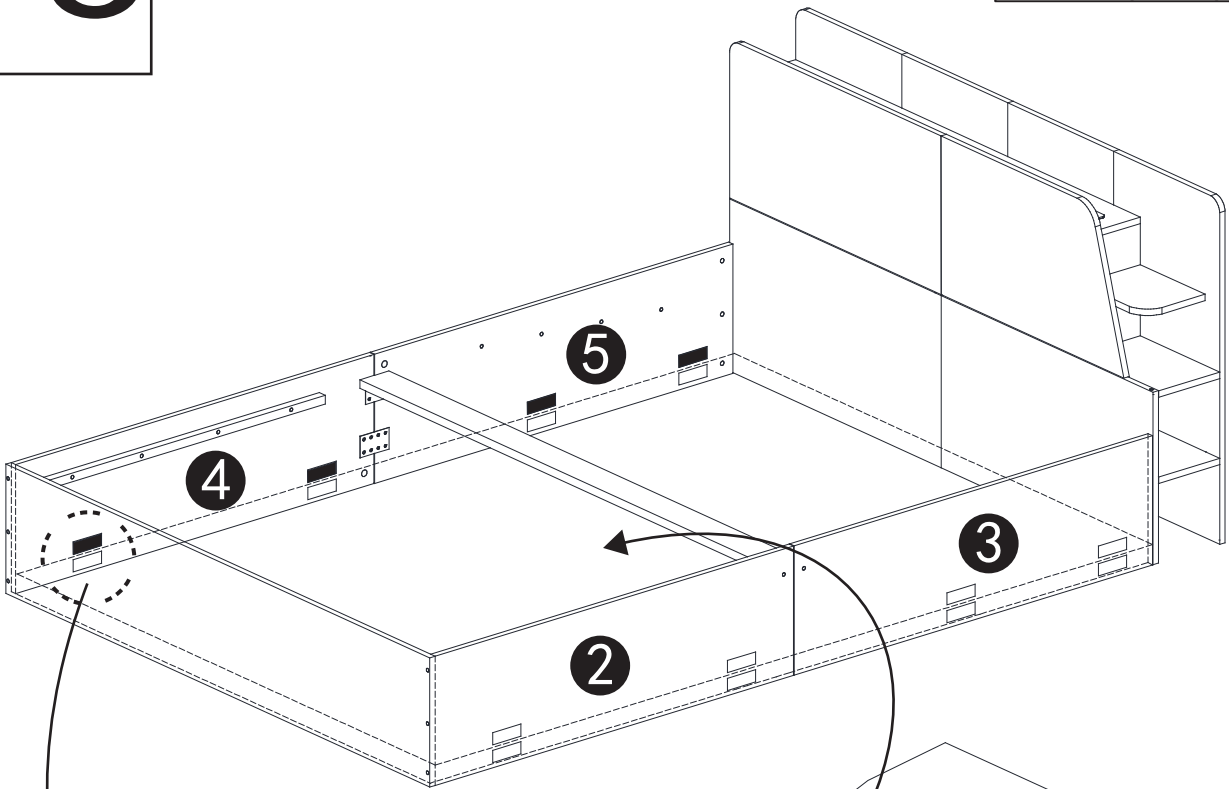
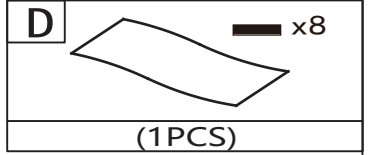

A	B
	
M6*90mm	M6*60mm(12PCS)



13

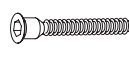

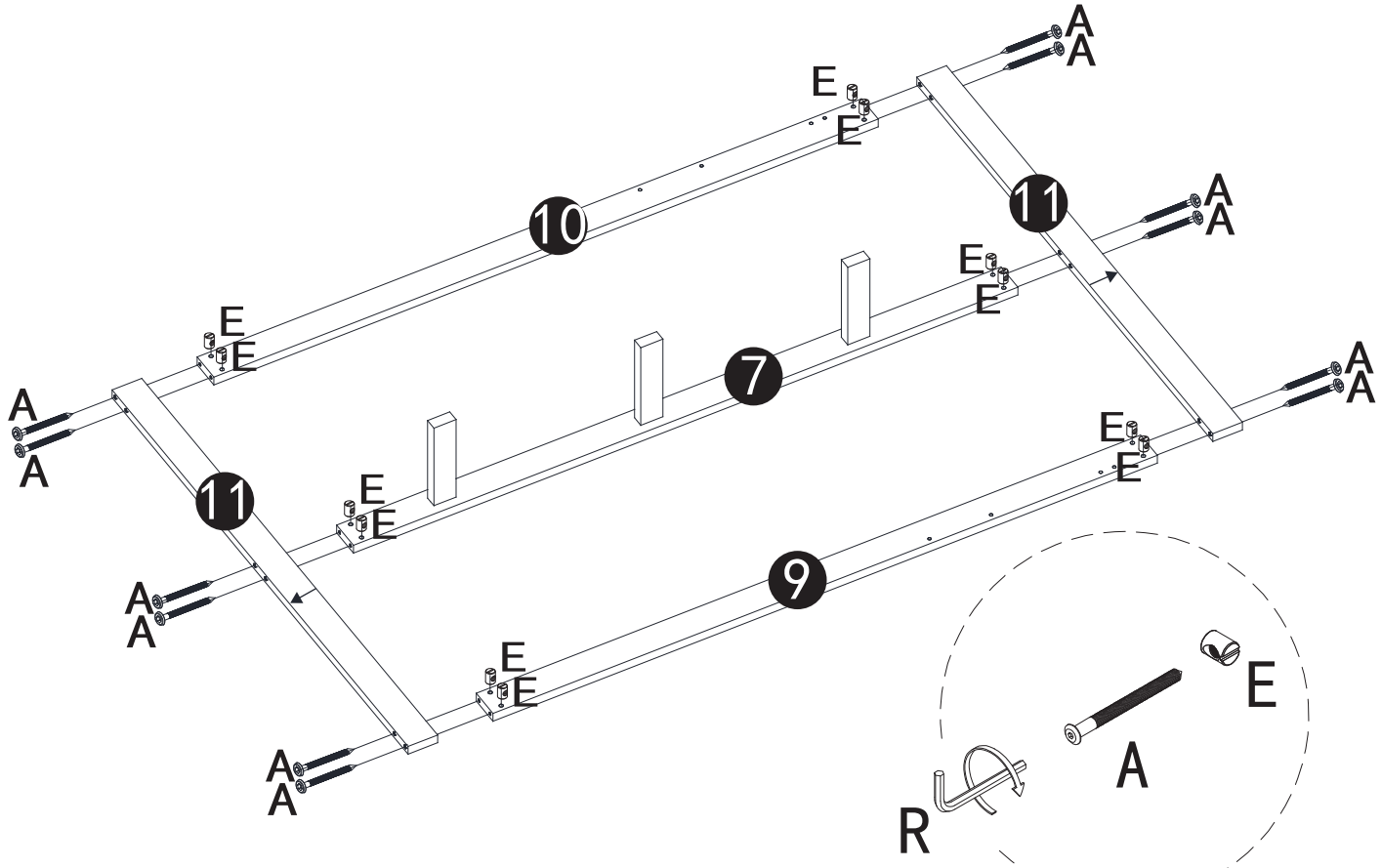
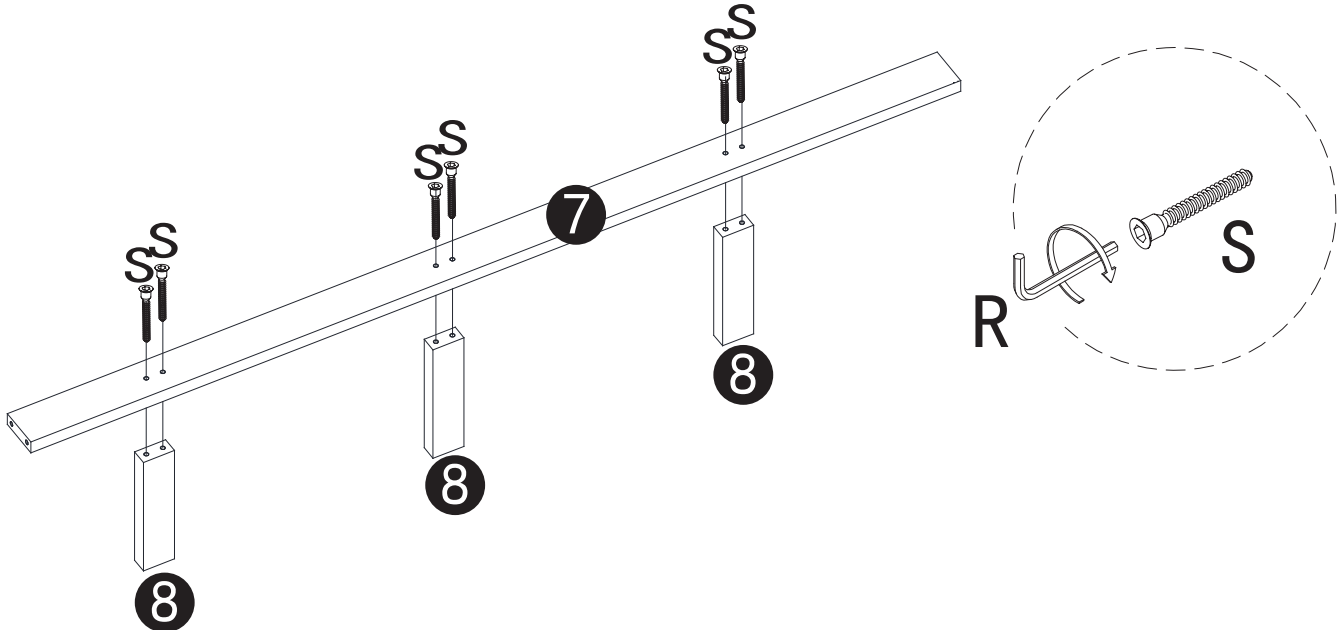

14

E	A	S	R
			
12PCS	12PCS	6PCS	1PC





A	B
	
M6*90mm(12PCS)	M6*60mm

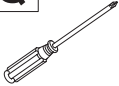

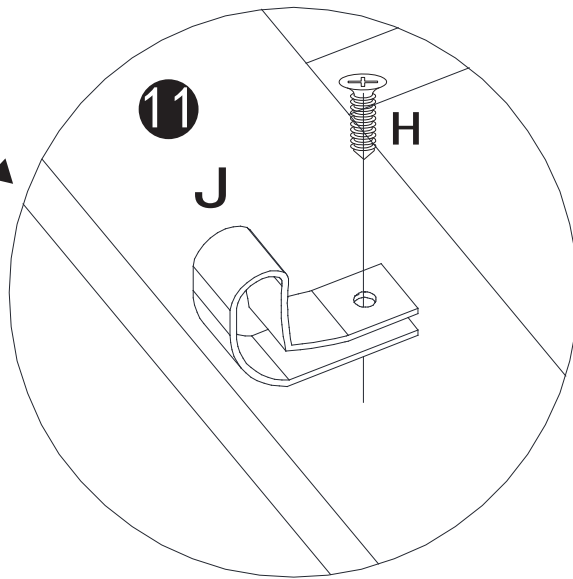
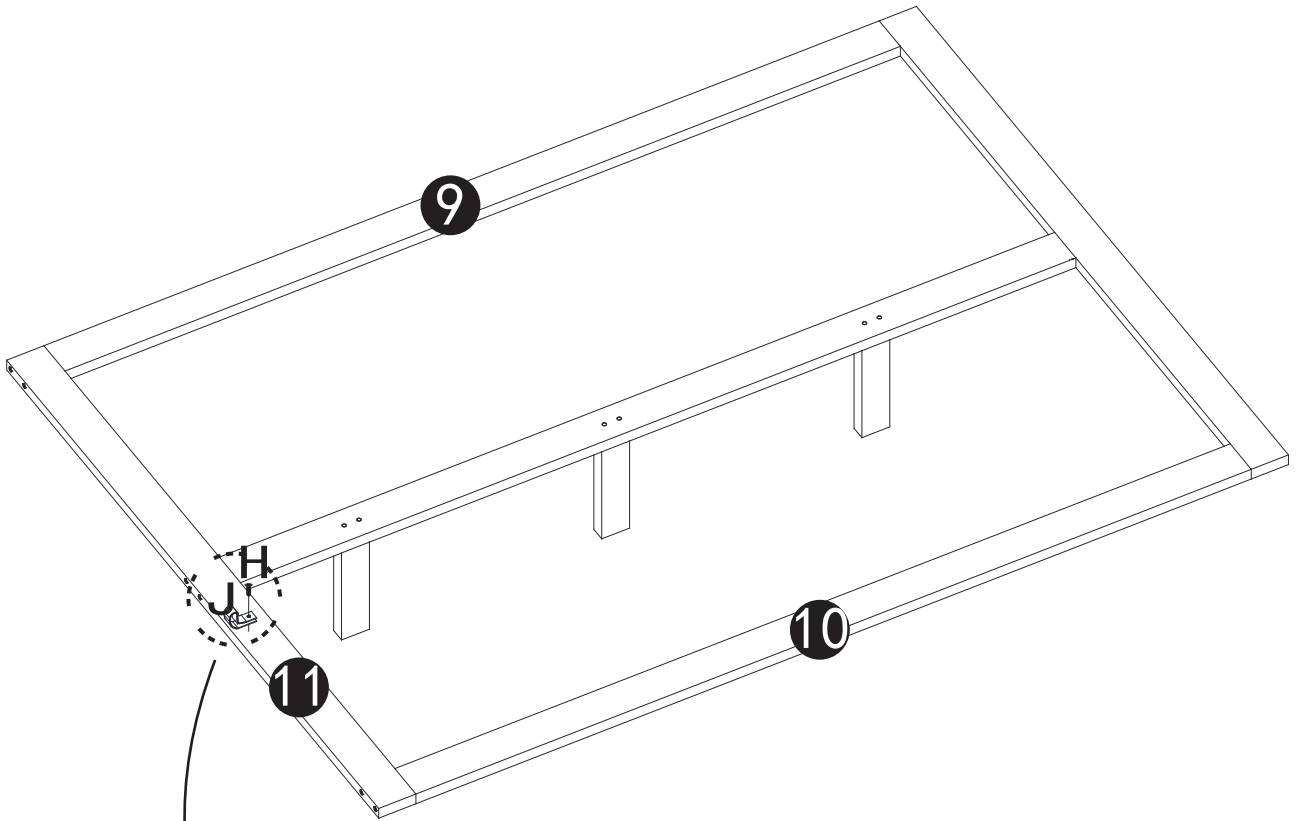



15

J 	H 	Q 
1PC	1PC	1PC





F 	H 
$\Phi 4 * 30\text{mm}$	$\Phi 3.5 * 14\text{mm}(1\text{PC})$

16

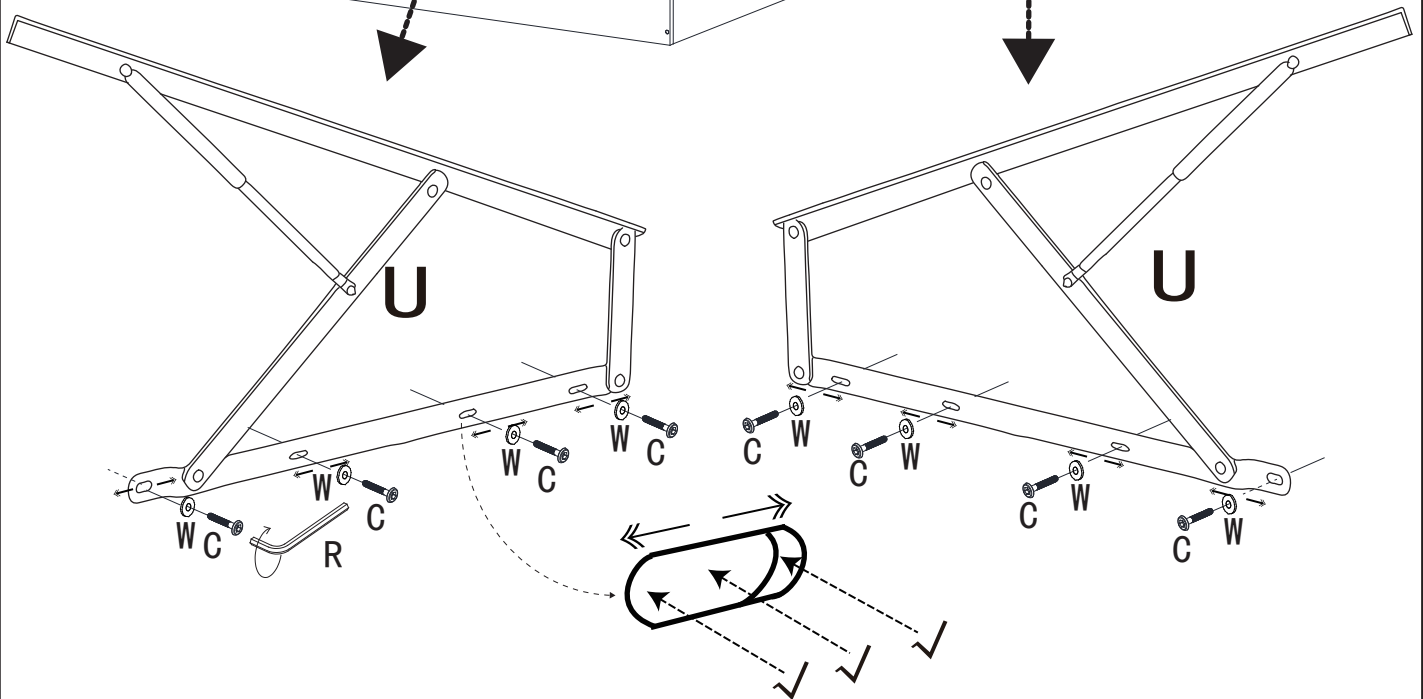
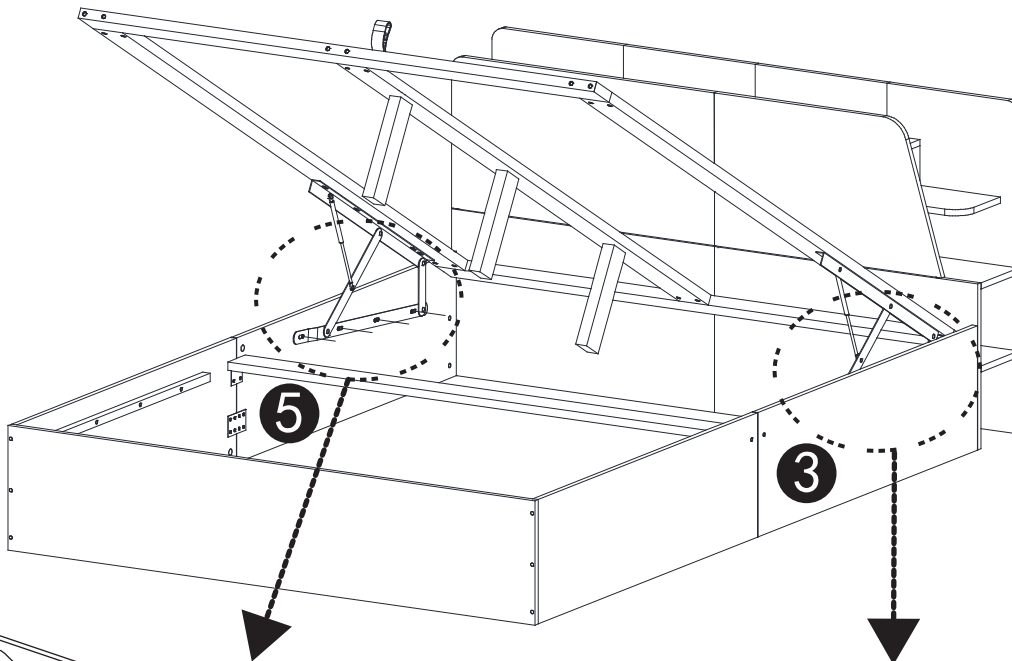
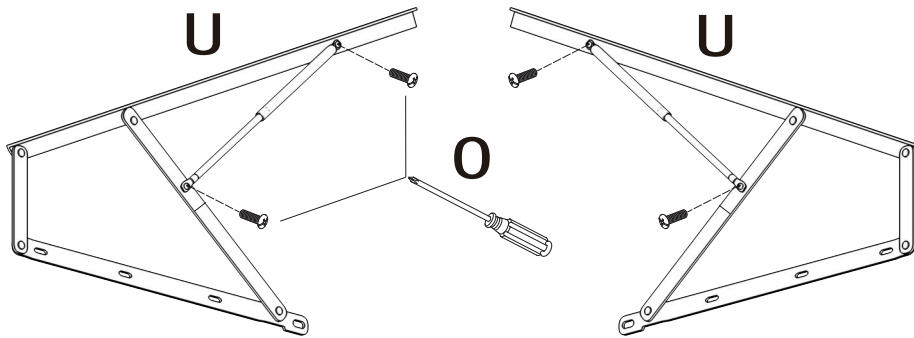
W 	O 	U  	R 	C 
8PCS	1PC	(1PC)	1PC	8PCS

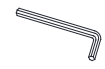

17

R	C
	
1PC	6PCS

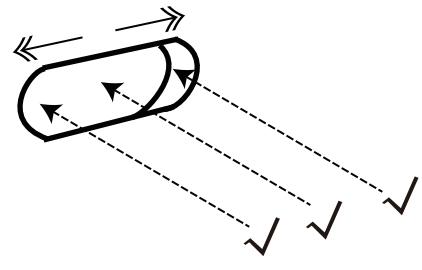
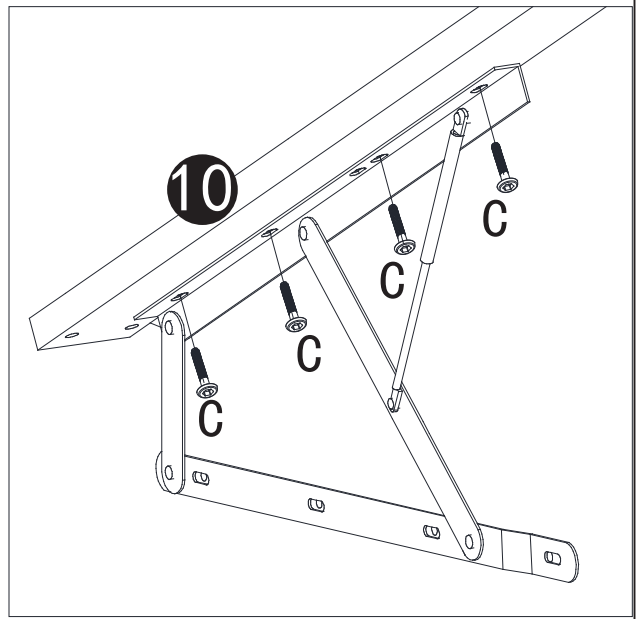
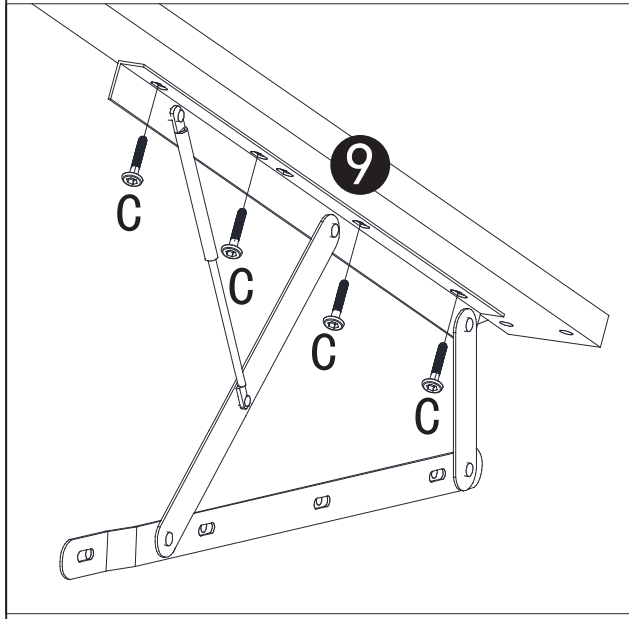
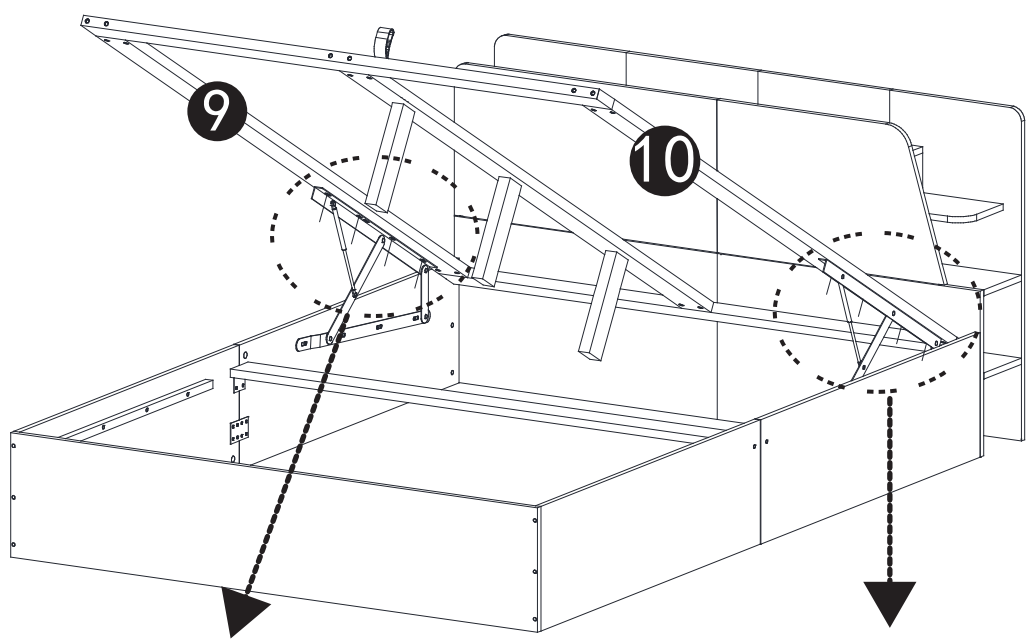

18

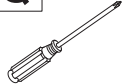
F	Q
	
30PCS	1PC

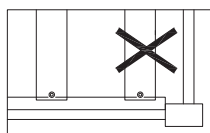
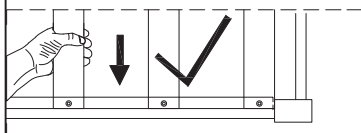
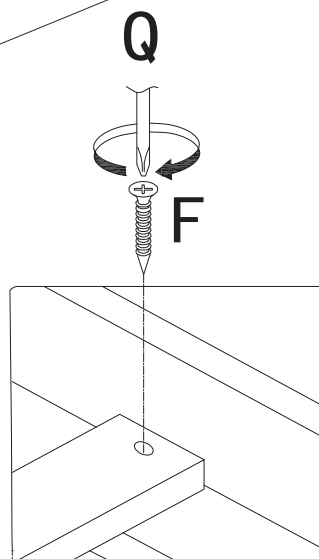
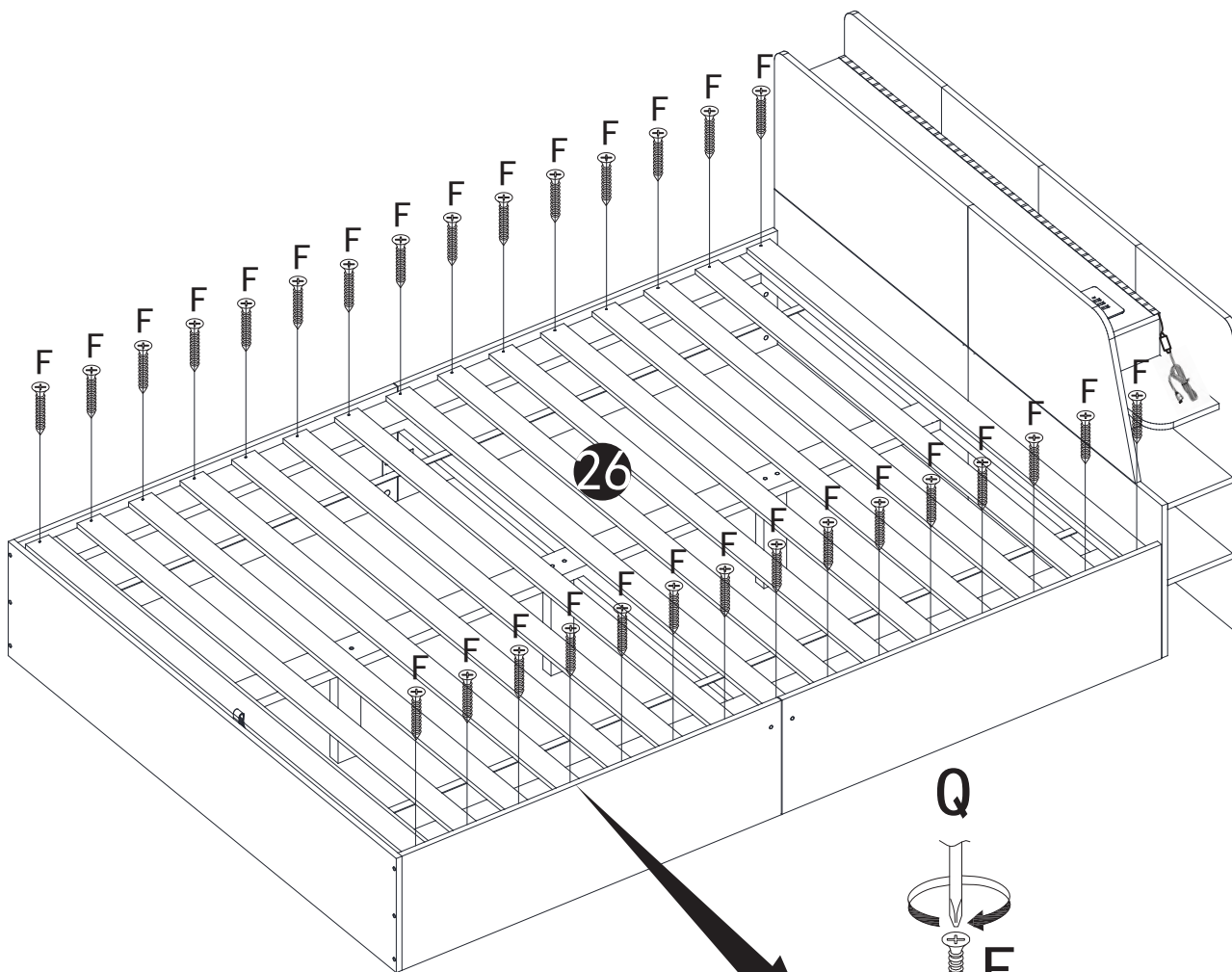

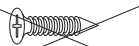
F		H	
Φ4*30mm(30PCS)		Φ3.5*14mm	

19

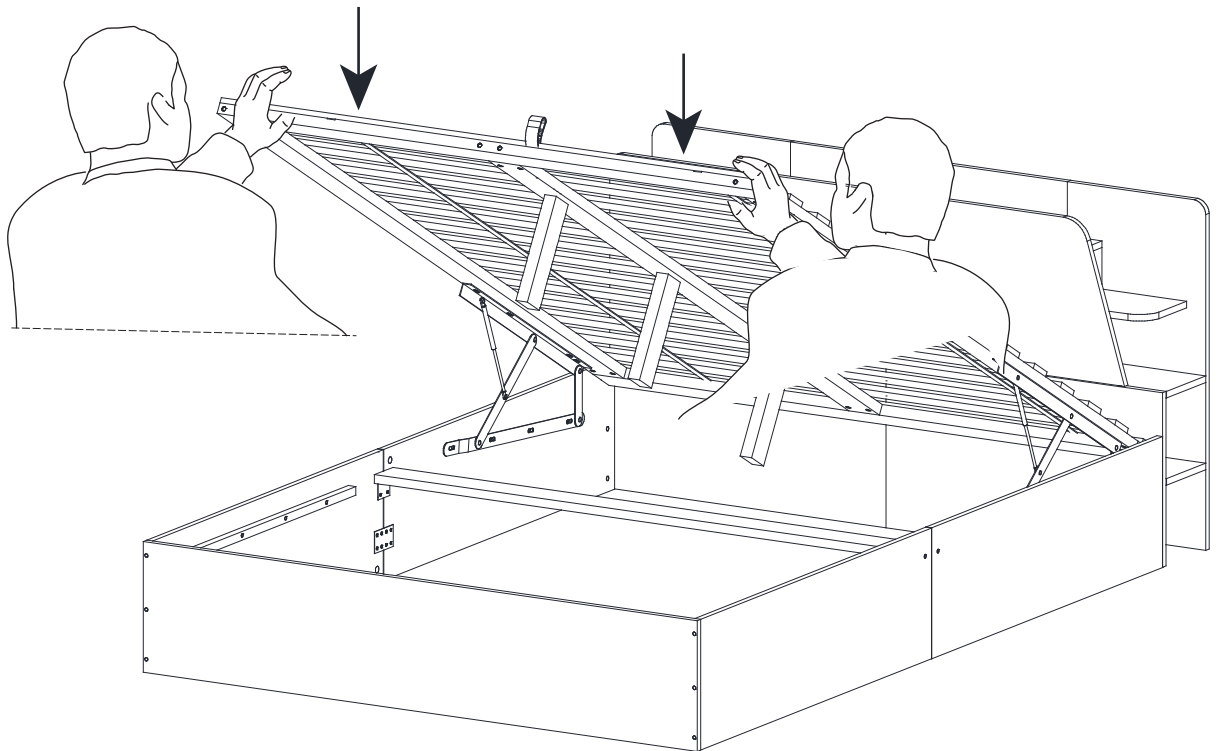
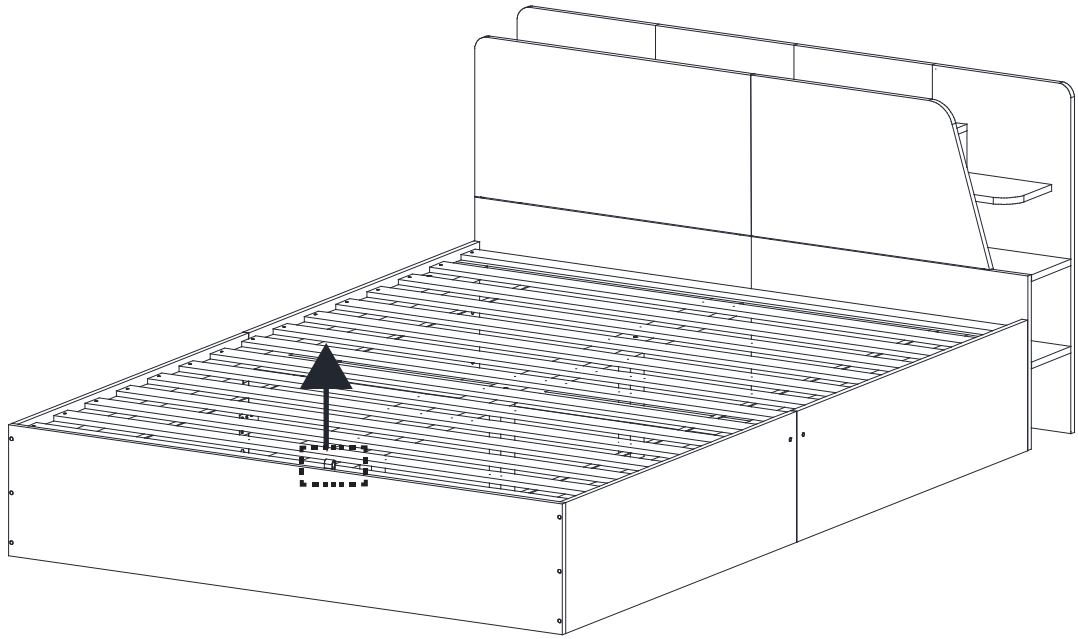

Certificate No. FCS202503546CA01

Product British socket

Brand Name Using

Model(s) No. YS-8033

Series Model YS-8034, YS-8035, YS-8036, YS-8037, YS-8038, YS-8039, YS-135801, YS-135802, YS-135803, YS-135804, YS-135805

Holder Shenzhen Using Intelligent Technology CO.,LTD.

Address A1605, Excellence Meilin Center Square (South District), No. 126 Zhongkang Road, Meidu Community, Meilin Street, Futian District, Shenzhen

Manufacturer Shenzhen Using Intelligent Technology Co., Ltd. Dongguan Branch

Address 5th Floor, Building 2, No. 55 West Road, Shilong Section, Dongjiang Avenue, Shilong Town, Dongguan City, Guangdong Province

Report No. FCS202503546E02



TEST STANDARDS:

EN 55032:2015/A1:2020
EN 55035:2017/A11:2020
EN 61000-4-2:2009 EN IEC 61000-4-3:2020
EN 61000-4-4:2012 EN 61000-4-5:2014/A1:2017
EN 61000-4-6:2013 EN 61000-4-8:2010
EN 61000-4-11:2004/A1:2017

The applicant of the certificate is authorized to use this certificate in connection with EC declaration of conformity to the Directive. The certificate is only applicable to the equipments described above.

The submitted sample of the above equipment has been tested and found to comply with the following European Directive

EMC Directive - 2014/30/EU



Approved by: *Jack Wang*
March 28, 2025
Jack Wang/Managerial



The statement is based on a single evaluation of the sample of above mentioned product(s). It does not imply an assessment of the whole production.

Dongguan Funas Testing Technology Co.,Ltd.
Add: Room 105 Floor Bao hao Technology Building 1 NO.15 Gong ye West Road Hi-TechIndustrial, Song shan lake Dongguan, China
Tel: 0769-27280901 Fax:0769-27280901 <http://www.fcs-lab.com>
E-mail:andy.yue@fcs-lab.com

Certificate No. FCS202503546CA02



Product British socket

Brand Name Using

Model(s) No. YS-8033

Series Model YS-8034, YS-8035, YS-8036, YS-8037, YS-8038, YS-8039, YS-135801, YS-135802, YS-135803, YS-135804, YS-135805

Holder Shenzhen Using Intelligent Technology CO.,LTD.

Address A1605, Excellence Meilin Center Square (South District), No. 126 Zhongkang Road, Meidu Community, Meilin Street, Futian District, Shenzhen

Manufacturer Shenzhen Using Intelligent Technology Co., Ltd. Dongguan Branch

Address 5th Floor, Building 2, No. 55 West Road, Shilong Section, Dongjiang Avenue, Shilong Town, Dongguan City, Guangdong Province

Report No. FCS202503546A01

TEST STANDARDS:

EN IEC 62368-1:2024 + A11:2024

The applicant of the certificate is authorized to use this certificate in connection with EC declaration of conformity to the Directive. The certificate is only applicable to the equipments described above.

The submitted sample of the above equipment has been tested and found to comply with the following European Directive

LVD Directive - 2014/35/EU Directive



Approved by: *Jack Wang*

 March 28, 2025
 Jack Wang/Managerial



The statement is based on a single evaluation of the sample of above mentioned product(s). It does not imply an assessment of the whole production.

Dongguan Funas Testing Technology Co.,Ltd.

Add: Room 105 Floor Bao hao Technology Building 1 NO.15 Gong ye West Road Hi-TechIndustrial, Song shan lake Dongguan, China

Tel: 0769-27280901 Fax:0769-27280901 <http://www.fcs-lab.com>

E-mail:andy.yue@fcs-lab.com



Supplier's Declaration of Conformity

Certificate No. FCS202503546FV01
Product British socket
Brand Name Using
Model(s) No. YS-8033
Series Model YS-8034, YS-8035, YS-8036, YS-8037, YS-8038, YS-8039, YS-135801, YS-135802, YS-135803, YS-135804, YS-135805
Holder Shenzhen Using Intelligent Technology CO.,LTD.
Address A1605, Excellence Meilin Center Square (South District), No. 126 Zhongkang Road, Meidu Community, Meilin Street, Futian District, Shenzhen
Manufacturer Shenzhen Using Intelligent Technology Co., Ltd. Dongguan Branch
Address 5th Floor, Building 2, No. 55 West Road, Shilong Section, Dongjiang Avenue, Shilong Town, Dongguan City, Guangdong Province
 The products electromagnetic emission have been tested to conform to the applicable FCC Rules and Regulations:
FCC 47 CFR Part 15: Subpart B

The test result has been evaluated by Flux Compliance Service Laboratory and showed in the test report. (Report No. : FCS202503546E01)
 Operation is subject to the following two conditions:
 (1) This device may not cause harmful interference,
 (2) This device must accept any interference received, including interference that may cause undesired operation.
 It is understood that each unit marketed is identical to the device as tested, and any changes to the device that could adversely affect the emission characteristics will require retest.
 Without the written approval of Flux Compliance Service Laboratory, this verification is not permitted to be reproduced, except in full. It is not permitted to use the test lab's logo.



Approved by: *Jack Wang*
 March 28, 2025
 Jack Wang/Managerial



The statement is based on a single evaluation of the sample of above mentioned product(s). It does not imply an assessment of the whole production.

Flux Compliance Service Laboratory

Add: Room 105, 1/F., Baohao Technology Building 1, No.15, Gongye West Road,
 Songshan Lake Hi-Tech Industrial Area, Dongguan, Guangdong, China
 Tel: 0769-27280901 Web: <http://www.fcs-lab.com> E-mail: andy.yue@fcs-lab.com

CERTIFICATE OF CONFORMITY

Certificate No.: KEYS241104015001RH-03R1

Applicant : SHENZHEN Using Intelligent Technology CO.,LTD.
Address : No. 22 Chenwu Road, Dakang Community, Yuanshan Street, Longgang District, Shenzhen
Manufacturer : Shenzhen Yousheng Intelligent Technology Co., Ltd. Dongguan Branch
Address : Room 504, Building 2, No. 55 West Shilong Section, Dongjiang Avenue, Shilong Town, Dongguan City, Guangdong Province
Sample Name : British socket
Trademark : Using
Main Model : YS-UK1660
Additional model : YS-UK1661,YS-UK1662,YS-UK1663,YS-UK1664,YS-UK1665,
IYS-MU1661,YS-MU1662,YS-MU1663,YS-MU1664,YS-MU1665,
YS-EU1661,YS-EU1662,YS-EU1663,YS-EU1664,YS-EU1665,YS-8033

RoHS 2.0 Directive (EU) 2015/863 and (EU)2017/2102 amending Annex II to Directive 2011/65/EU.

The standard(s) used for showing compliance with the essential requirements:

Applicable Standard(s) IEC 62321-3-1: 2013
IEC 62321-4:2013 +AMD1:2017
IEC 62321-5:2013
IEC 62321-6:2015
IEC 62321-7-1:2015
IEC 62321-7-2:2017
IEC 62321-8:2017

The EUT described above has been consolidated by us and found in compliance with the council RoHS 2.0 Directive (EU) 2015/863 and (EU)2017/2102 amending Annex II to Directive 2011/65/EU.

The certificate applies to the tested sample above mentioned only and shall not imply an assessment of the whole production. It is only valid in connection with the test report number. KEYS241104015001RH-03R1

RoHS



Tony Qian/Approved Signatory

Date: Nov.06, 2024



Scan to view
the original file

Guangdong KEYS Testing Technology Co., Ltd.

Address: Building 1, No.18, Shihuan Road, Dongcheng Subdistrict, Dongguan, Guangdong, China
Tel:+ 86-0769-89798319 <http://www.keys-lab.com> E-mail: info@keys-lab.com



This certificate is responsible for testing sample only.
Please refer to this corresponding test report to get testing process and data.

CERTIFICATE

ATTESTATION Certificate of Compliance

Technical file of the company mentioned below has been inspected and audit has been completed successfully

The Low Voltage Directive 2014/35/EU has been taken as references for these processes

Certificate's Holder : Shenzhen xu xing technology co., LTD
 Address : Floor 3, building C, Huaze hi tech Industrial Park, Shiyang street, Bao'an District, Shenzhen
 Manufacturer : Shenzhen xu xing technology co., LTD
 Address : Floor 3, building C, Huaze hi tech Industrial Park, Shiyang street, Bao'an District, Shenzhen
 Product Name : XX LED RGB STRIP
 Product Model (S) : XX5050RGB-60D, 5V-5050RGB-30D, 5V-5050RGB-60D, 12V-5050RGB-60D, 12V-5050RGB-30D, DY05RGB122, DY05RGB140, DY05RGB88
 Trade Mark : N/A
 Related Directive : 2014/35/EU
 Related Standards : EN IEC 60598-2-1:2021 used in conjunction with EN IEC 60598-1:2021 + AMD11:2022

Certificate Number : HK2509022741S
 Report No. : HK2509022741-SR
 Registration Date : Oct. 21, 2025

Jason Zhu
 Certification Manager



The information of the certificate can be checked through <https://www.huak.com>. The CE mark which is shown on the certificate can only be used under the conditions that the products complete with all of the relevant Directives of CE Declaration of Conformity. The Manufacturer should be responsible for the internal production control so that the products complied with the essential requirements of the above mentioned Directive(s). Certificate holder must notify all changes to the original certification laboratory of HUAKE.

Shenzhen HUAKE Testing Technology Co., Ltd.

Address: 1-2/F, B2 Building, Junfeng Zhongcheng Zhizao Innovation Park, Heping Community, Fuhai Street, Bao'an District, Shenzhen, China
Tel.: +86-0755-2302 9901 E-mail: info@huak.com Website: <https://www.huak.com>



This certificate is responsible for testing sample only.
Please refer to this corresponding test report to get testing process and data.

CERTIFICATE

ATTESTATION Certificate of Compliance

Technical file of the company mentioned below has been inspected and audit has been completed successfully

The RED Directive 2014/53/EU has been taken as references for these processes.

Certificate's Holder : Shenzhen xu xing technology co., LTD
 Address : Floor 3, building C, Huaze hi tech Industrial Park, Shiyan street, Bao'an District, Shenzhen
 Manufacturer : Shenzhen xu xing technology co., LTD
 Address : Floor 3, building C, Huaze hi tech Industrial Park, Shiyan street, Bao'an District, Shenzhen
 Product Name : XX LED RGB STRIP
 Product Model (S) : XX5050RGB-60D, 5V-5050RGB-30D, 5V-5050RGB-60D, 12V-5050RGB-60D, 12V-5050RGB-30D, DY05RGB122, DY05RGB140, DY05RGB88
 Trade Mark : N/A
 Related Directive : 2014/53/EU
 Article 3.1a) : EN IEC 62368-1:2024 + A11:2024
 EN 62479:2010
 EN 50663:2017
 Related Standards : Article 3.1b) : ETSI EN 301 489-1 V2.2.3 (2019-11)
 ETSI EN 301 489-3 V2.3.2 (2023-01)
 EN IEC 61000-3-2:2019 + A1:2021 + A2:2024
 EN 61000-3-3:2013 + A1:2019 + A2:2021
 Article 3.2) : ETSI EN 300 220-1 V3.1.1 (2017-02)
 ETSI EN 300 220-2 V3.3.1 (2025-03)
 Certificate Number : HK2509024992E
 Report No. : HK2509024992-1SR/-2EH/-1ER/-2ER
 Registration Date : Oct. 21, 2025

Jason

Certification Manager



The information of the certificate can be checked through <https://www.huak.com>. The CE mark which is shown on the certificate can only be used under the conditions that the products complete with all of the relevant Directives of CE Declaration of Conformity. The Manufacturer should be responsible for the internal production control so that the products complied with the essential requirements of the above mentioned Directive(s). Certificate holder must notify all changes to the original certification laboratory of HUAKE.

Shenzhen HUAKE Testing Technology Co., Ltd.

Add.:1-2/F, B2 Building, Junfeng Zhongcheng Zhizao Innovation Park, Heping Community, Fuhai Street, Bao'an District, Shenzhen, China
Tel.:+86-0755-2302 9901 E-mail:info@huak.com Website:https://www.huak.com



Shenzhen POCE Technology Co.,Ltd.

H Building, Hongfa Science and Technology Park,
Tangtou, Shiyao, Bao'an District, Shenzhen, China

CERTIFICATE OF CONFORMITY

Certificate No : POCE220829292TCE
Applicant : Shenzhen Xuxing Technology Co.,Ltd
Address : Floor 3, Building C, Huaze Hi-Tech Industrial Park, No.108 Zhushi Road, Shiyao Street, Bao'an District, Shenzhen
Manufacturer : Shenzhen Xuxing Technology Co.,Ltd
Address : Floor 3, Building C, Huaze Hi-Tech Industrial Park, No.108 Zhushi Road, Shiyao Street, Bao'an District, Shenzhen
Product : Led lights bring

Trade Name : 
旭兴科技
XUXING TECHNOLOGY

Model(s) : XX5050-RGB-60D, XX5050-RGB-30D, XX5050-RGB-72D, XX5050-RGB-96D, XX5050-RGB-120D, CLB1-2835-1, CLB1-2835-0, XX2835-W/Y-120D, XX2835-W/Y-60D, XX2835-W/Y-240D, XX2835-W/Y-238D, XX2835-W/Y-168D, XX2835-W/Y-224D, XX2835-W/Y-118D, XX2835-W/Y-162D, XX2835-W/Y-124D, XX2835-W/Y-170D, XX2835-60D, XX2835-120D, XX2835-150D, XX2835-180D

Test Report No : POCE220829292TRE
Test Standards : **EN IEC 55015:2019/A11:2020**
EN 61547:2009
EN IEC 61000-3-2:2019/A1:2021
EN 61000-3-3:2013/A2:2019

The EUT described above has been tested by us with the listed standards and found in compliance with the council EMC Directive 2014/30/EU. It is possible to use CE marking to demonstrate the compliance with this EMC Directive.



For Chief Executive / Tom Chen
Date: Sep. 02, 2022

This certificate of conformity is based on a single evaluation of the submitted sample(s) of the above mentioned product. It does not imply an assessment of the whole production and other relevant directives have to be observed.



扫一扫关注



扫码查证书



Shenzhen POCE Technology Co.,Ltd.

H Building, Hongfa Science and Technology Park,
Tangtou, Shiyao, Bao'an District, Shenzhen, China

CERTIFICATE OF CONFORMITY

Certificate No. : POCE220829293QCR
Applicant : Shenzhen Xuxing Technology Co., Ltd
Address : Floor 3, Building C, Huaze Hi-Tech Industrial Park, No. 108
Zhushi Road, Shiyao Street, Bao'an District, Shenzhen
Manufacturer : Shenzhen Xuxing Technology Co., Ltd
Address : Floor 3, Building C, Huaze Hi-Tech Industrial Park, No. 108
Zhushi Road, Shiyao Street, Bao'an District, Shenzhen
Product : Led lights bring
Trade Name : 
Model(s) : XX5050-RGB-60D, XX5050-RGB-30D, XX5050-RGB-72D,
XX5050-RGB-96D, XX5050-RGB-120D, CLB1-2835-1,
CLB1-2835-0, XX2835-W/Y-120D, XX2835-W/Y-60D,
XX2835-W/Y-240D, XX2835-W/Y-238D, XX2835-W/Y-168D,
XX2835-W/Y-224D, XX2835-W/Y-118D, XX2835-W/Y-162D,
XX2835-W/Y-124D, XX2835-W/Y-170D, XX2835-60D,
XX2835-120D, XX2835-150D, XX2835-180D
Test Report No. : POCE220829293QRR
Test Standards : IEC 62321-3-1:2013; IEC 62321-4:2013+A1:2017;
IEC 62321-5:2013; IEC 62321-6:2015; IEC 62321-7-1:2015;
IEC 62321-7-2:2017; IEC 62321-8:2017

The EUT described above has been tested by us with the listed standards and found in compliance with the council **RoHS Directive(EU) 2015/863 amending Annex II to Directive 2011/65/EU**. It is possible to use **CE** marking to demonstrate the compliance with this **RoHS** Directive.



.....
For Chief Executive / Jerry Yang
Date: Sep. 02, 2022

This certificate of conformity is based on a single evaluation of the submitted sample(s) of the above mentioned product. It does not imply an assessment of the whole production and other relevant directives have to be observed.



扫一扫关注

扫码查证书

Led Bluetooth Mini Controller Manual



Download App Software

Please download "LotusLamp X" in the app store or scan the QR code below to download.



1. Download the "LotusLamp X" app with your phone by scanning the QR code on the user manual or searching for the Lotus Lamp app in the iPhone App Store or Google Play Store

2. After the APP are downloaded successfully, you need to turn on Bluetooth function on your phone firstly, then plug in the strip light, then open the APP, your APP will pair with the strip light automatically and you can control it.

Unable to Connect Troubleshooting

- (1) Check if the power supply of the light strip is normal.
- (2) Check if the Bluetooth is turn on.
- (3) Check if there are other mobile phone are connected, Bluetooth 4.0 only support connections one to many, dose not support many to many.
- (4) Check APP Bluetooth setting if the phone is connected to the device, if connect, exit the APP and reopen, the APP will go to connect automatically.
- (5) Normal operations and can not connect, please exit the APP and reopen.
- (6) Exit APP, restart mobile phone, power on the strip light, reopen the APP, then them will connect automatically.

Instructions

Scan the code or search to get the following APP, open the APP

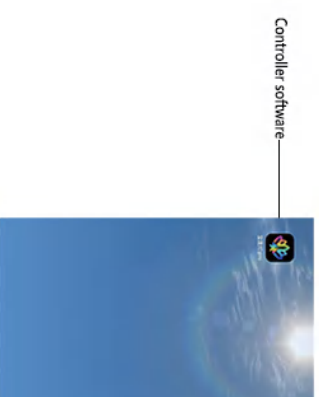

1. Open the control software to get the following interface

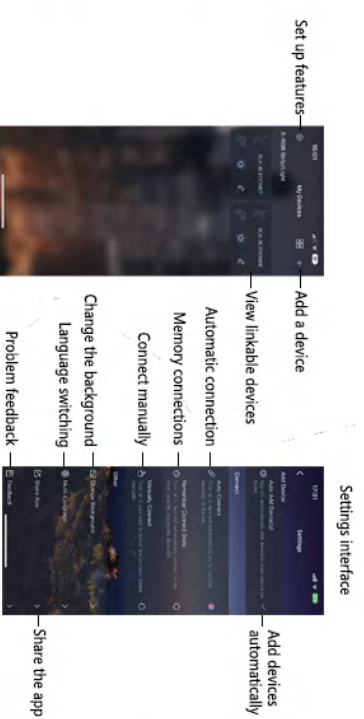

Clicking on the connected device will appear as shown in the dashboard image on the right.

Tap Connected devices

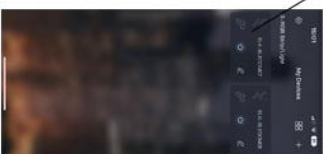

Displays the connection status



2. Use the color palette function when connecting devices.



- (1) Drag the ring to switch colors
- (2) Click on the RGB value to adjust the color
- (3) Tap Color to toggle
- (4) Click Pattern + and press (1) to perform color DIY
(Long press DIY color to redo color DIY)
- (5) Drag the white point to adjust the brightness

3. Use the rhythm function when connecting the device.



- (1) Device MIC: Sound rhythm is received through the device
(four rhythm modes can be selected under the receiving sound rhythm through the device)
- (2) Phone MIC: Receive sound rhythm via your phone
- (3) Music: By selecting a music groove
- (4) Sensitivity: Drag the white point to adjust the receive responsiveness

4. Use the mode function when connecting the device.



- Swipe / Tap the screen to switch static colors or jump changes and other functions
- Slide the white dot to adjust the flashing speed in the changing state
- Slide the white dot to adjust the brightness

5. Use scene features when connecting devices.

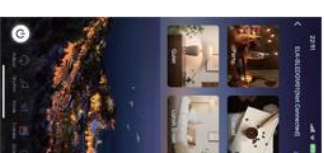

The scene function intelligently adjusts the flickering effect according to the system.

6. Use the timing function when connecting the device.

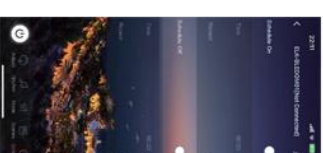

- Turn on the lights regularly
- Set the auto-start time and date by clicking to select
- Turn off the lights regularly
- Set the automatic lights off time and date by clicking to select

The timing function can be used together in other modes.