

# MONTAGEANLEITUNG/ASSEMBLY INSTRUCTIONS

Artikelnummer/Item Number:WF324570WAA

Bett Betragt 140x200cm

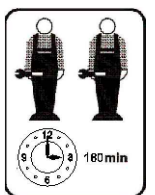
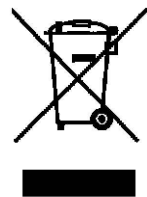
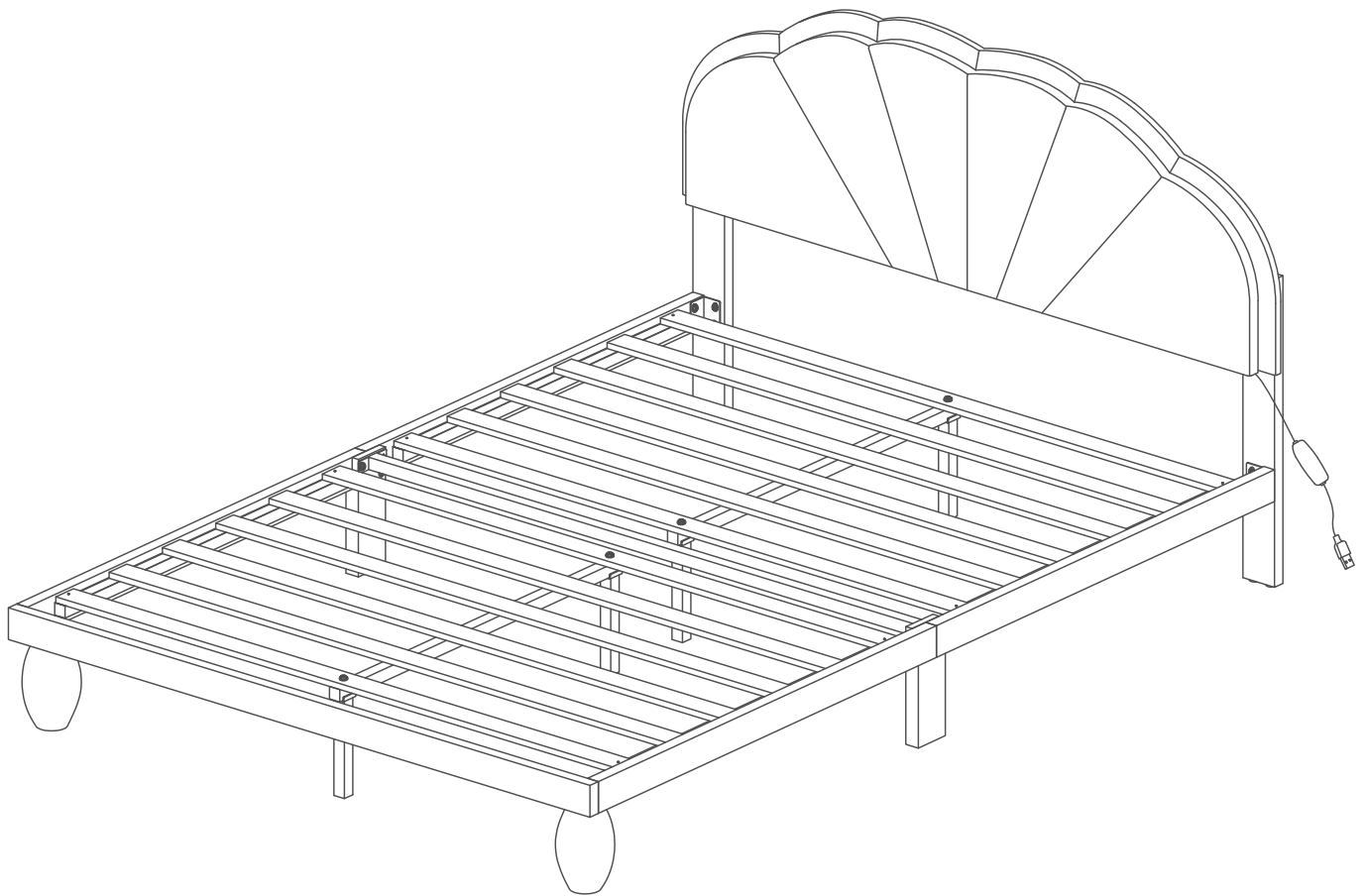

# INSTRUCTIONS

## IMPORTANT-READ CAREFULLY-RETAIN FOR FUTURE REFERENCE

- a) **WARNING** -Children can become trapped between the bed and the wall, the adjoining pieces of furniture (e.g. cupboards) and the like. To avoid risk of serious injury the distance between the safety barrier and the adjoining structure shall not exceed 90 mm or shall be more than 230 mm.
- b) **WARNING**-Do not use the bed if any structural part is broken or missing; Replacement parts are between requested from the manufacturer or the store.
- c) **WARNING**-Do not climb or wiggle on any non-designated structures.
- d) it is imperative to always follow the installation instructions and manufacturer's use.
- e) **The recommended size of the mattress to be used with the bed is 140cmx200cm, maximum thickness mattress:20cm.**
- f) It is necessary to ventilate the room in order to maintain a low level moisture and prevent mold growth in the bed and its periphery.
- g) Joining devices should always be tightened properly and regularly verified. Tighten if necessary.

# ANLEITUNGEN

## WICHTIG - SORGFÄLTIG LESEN - FÜR SPÄTERE VERWENDUNG

### AUFBEWAHREN

- a) **WARNUNG** -Kinder können zwischen dem Bett und der Wand, den angrenzenden Möbelstücken (z. B. Schränken) und der Lücke eingeklemmt werden. Um die Gefahr schwerer Verletzungen zu vermeiden, darf der Abstand zwischen der Sicherheitsbarriere und der angrenzenden Struktur nicht mehr als 90 mm oder mehr als 230 mm betragen.
- b) **WARNUNG**-Das Bett darf nicht benutzt werden, wenn ein Bauteil gebrochen ist oder fehlt; Ersatzteile sind beim Hersteller oder im Geschäft anzufordern.
- c) **WARNUNG**-Klettern oder wackeln Sie nicht auf nicht dafür vorgesehenen Strukturen.
- d) Befolgen Sie unbedingt die Installationsanweisungen und die Gebrauchsanweisungen des Herstellers.
- e) **Die empfohlene Größe der Matratze für das Bett beträgt 140x200cm, maximale Dicker der Matratze: 20cm.**
- f) Es ist notwendig, den Raum zu lüften, um die Feuchtigkeit niedrig zu halten und Schimmelbildung im Bett und seiner Umgebung zu verhindern.
- g) Die Verbindungselemente sollten immer richtig angezogen sein und regelmäßig überprüft werden. Ziehen Sie sie gegebenenfalls nach.

## English

### IMPORTANT ! KEEP FOR FUTURE REFERENCE : READ CAREFULLY

- To be assembled by an adult. Assembly must be checked by an adult before use
- WARNING ! Keep all screws, small parts and plastic bags out of the reach of children
- Properly identify all parts before assembling
- Never use your item if any of its parts are broken or missing
- Should any problems arise, please contact our After Sales Service
- Manufacturer's instructions shall be followed at all times
- Care: Clean with a soft, dry cloth. In case of larger stains, carefully rub with a slightly damp, non-abrasive sponge
- Avoid the risk of fire by not placing furniture near sources of ignition or hot items
- Do not jump on the bed

## Deutsch

### WICHTIG ! ZUM SPÄTEREN NACHSCHLAGEN AUFBEWAHREN: SORGFÄLTIG LESEN

- Muss von einem Erwachsenen zusammengebaut werden. Der Zusammenbau muss vor dem Gebrauch von einem Erwachsenen überprüft werden
- WARNUNG! Bewahren Sie alle Schrauben, Kleinteile und Plastikbeutel außerhalb der Reichweite von Kindern auf
- Kennzeichnen Sie vor dem Zusammenbau alle Teile richtig
- Benutzen Sie Ihren Artikel niemals, wenn Teile gebrochen sind oder fehlen
- Sollten Probleme auftreten, wenden Sie sich bitte an unseren Kundendienst
- Die Anweisungen des Herstellers sind stets zu befolgen
- Pflege: Mit einem weichen, trockenen Tuch reinigen. Bei größeren Flecken vorsichtig mit einem leicht feuchten, nicht scheuernden Schwamm abreiben. nicht scheuernden Schwamm
- Vermeiden Sie die Gefahr eines Brandes, indem Sie die Möbel nicht in der Nähe von Zündquellen oder heißen Gegenständen aufstellen
- Nicht auf das Bett springen

## Français

### IMPORTANT ! CONSERVER POUR RÉFÉRENCE ULTÉRIEURE : LIRE ATTENTIVEMENT

- Le montage doit être effectué par un adulte. Le montage doit être vérifié par un adulte avant Utilisation
- ATTENTION ! Tenir les vis, les petites pièces et les sachets en plastique hors de portée des enfants
- Identifiez correctement toutes les pièces avant de les assembler
- N'utilisez jamais votre article si l'une de ses pièces est cassée ou manquante
- En cas de problème, veuillez contacter notre service après-vente
- Les instructions du fabricant doivent être respectées à tout moment
- Entretien : nettoyer avec un chiffon doux et sec. En cas de taches plus importantes, frotter soigneusement avec une éponge non abrasive légèrement humide. légèrement humide et non Abrasive
- Évitez les risques d'incendie en ne plaçant pas les meubles à proximité de sources d'inflammation ou d'objets chauds
- Ne pas sauter sur le lit

- Deve essere assemblato da un adulto. L'assemblaggio deve essere controllato da un adulto prima dell'uso
- ATTENZIONE! Tenere tutte le viti, le piccole parti e i sacchetti di plastica fuori dalla portata dei bambini
- Identificare correttamente tutte le parti prima dell'assemblaggio
- Non utilizzare mai l'articolo se alcune parti sono rotte o mancanti
- In caso di problemi, si prega di contattare il nostro Servizio Post Vendita
- Le istruzioni del produttore devono essere sempre seguite
- Cura: Pulire con un panno morbido e asciutto. In caso di macchie più estese, strofinare accuratamente con una spugna leggermente umida e nonspugna leggermente umida e non abrasiva
- Evitare il rischio di incendio, non collocando i mobili vicino a fonti di accensione o a oggetti caldi
- Non saltare sul letto

- Debe ser montado por un adulto. El montaje debe ser comprobado por un adulto antes del uso
- ADVERTENCIA Mantenga todos los tornillos, piezas pequeñas y bolsas de plástico fuera del alcance de los niños.
- Identifique correctamente todas las piezas antes de montarlas
- Nunca utilice su artículo si alguna de sus piezas está rota o falta
- Si surge algún problema, póngase en contacto con nuestro Servicio Postventa
- Las instrucciones del fabricante deben seguirse en todo momento
- Cuidado: Limpiar con un paño suave y seco. En caso de manchas más grandes, frote cuidadosamente con una esponja no abrasiva ligeramente humedecida.
- Evite el riesgo de incendio no colocando los muebles cerca de fuentes de ignición u objetos calientes.
- No saltar sobre la cama.

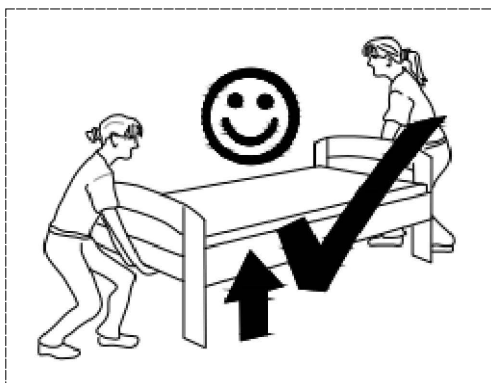
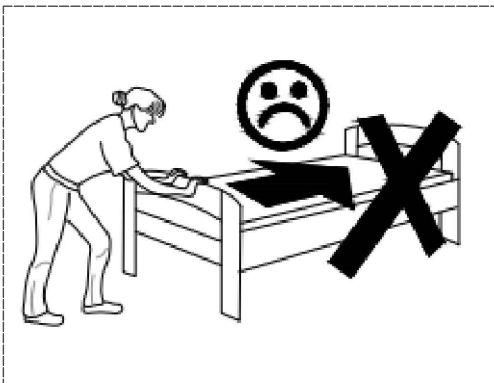



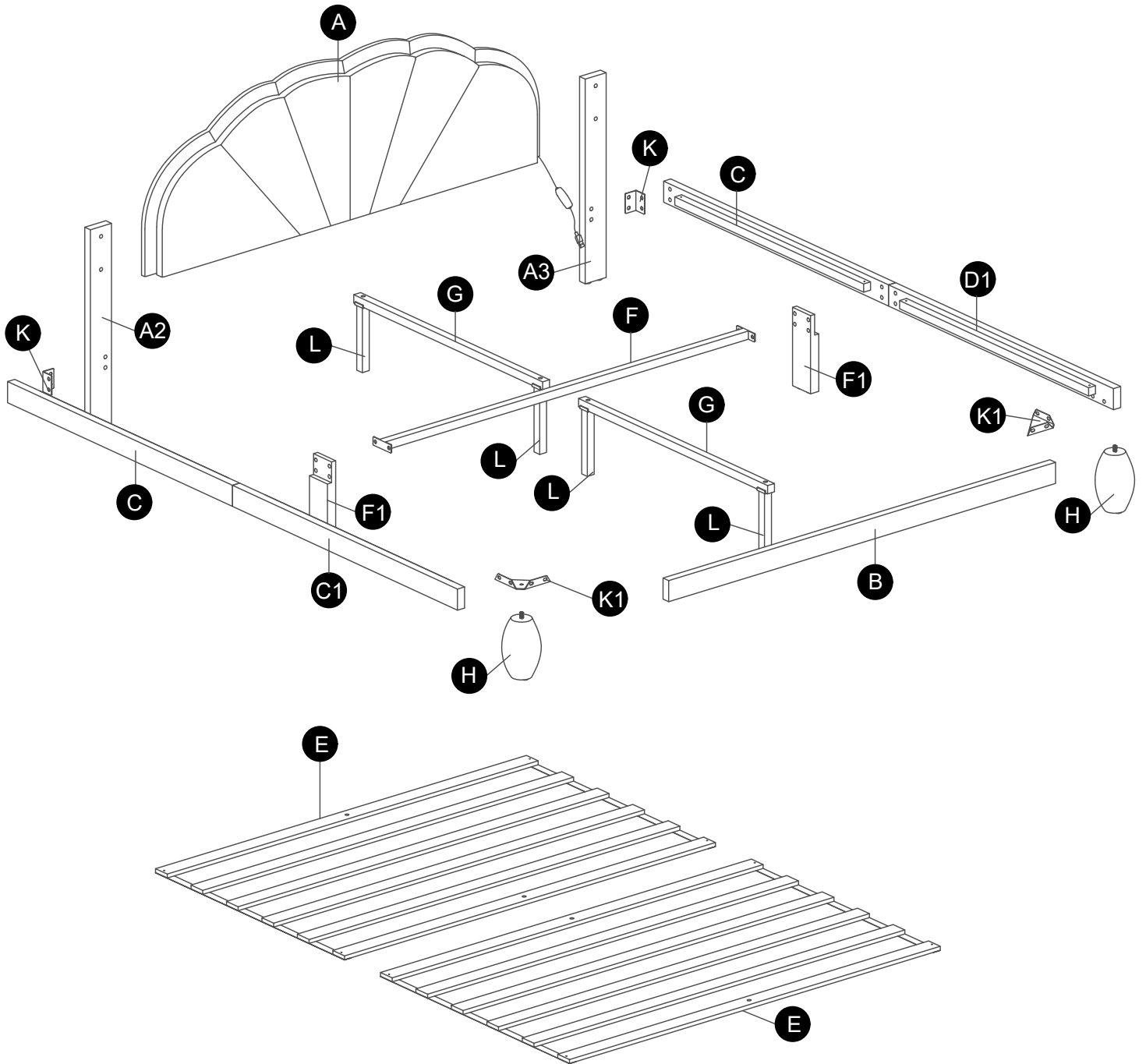



# Stückliste

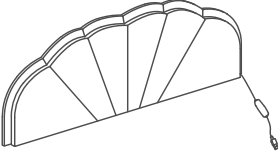

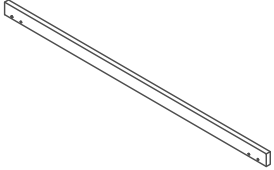
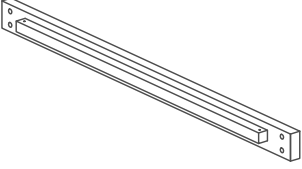
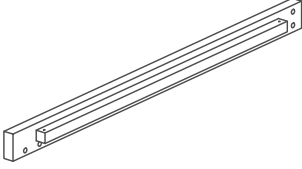
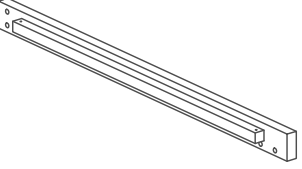
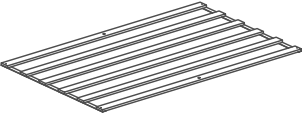
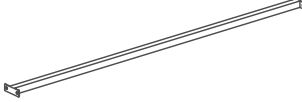

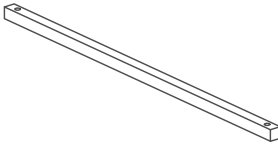
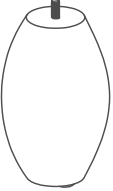
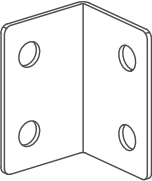
# PARTS LIST

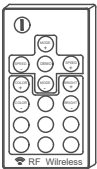
WF324570WAA

<p>(A) x1</p> 	<p>(A2) x1</p> 	<p>(A3) x1</p> 	<p>(B) x1</p> 
<p>(C) x2</p> 	<p>(C1) x1</p> 	<p>(D1) x1</p> 	<p>(E) x2</p> 
<p>(F) x1</p> 	<p>(F1) x2</p> 	<p>(G) x2</p> 	<p>(H) x2</p> 
<p>(K) x2</p> 	<p>(K1) x2</p> 	<p>(L) x4</p> 	<p>(M) x1</p> 

# PARTS LIST

WF324570WAA

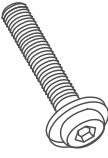
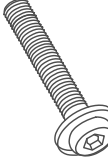
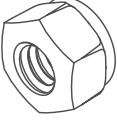
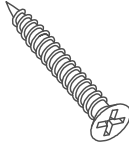
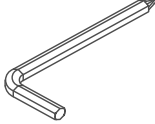
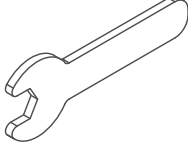
<p>① x8</p>  <p>M8*25</p>	<p>② x8</p>  <p>M8*25</p>	<p>③ x12</p>  <p>M8*40</p>	<p>④ x4</p>  <p>M8*50</p>
<p>⑤ x2</p>  <p>M8*6</p>	<p>⑥ x8</p>  <p>M4*30</p>	<p>⑦ x1</p>  <p>Allen Key M8</p>	<p>⑧ x1</p>  <p>Wrench</p>

# Stückliste

Note: Please do not tighten all bolts until the bed is assembled completely.

Hinweis: Bitte ziehen Sie alle Schrauben erst an, wenn das Bett vollständig montiert ist.

## Schritt 1

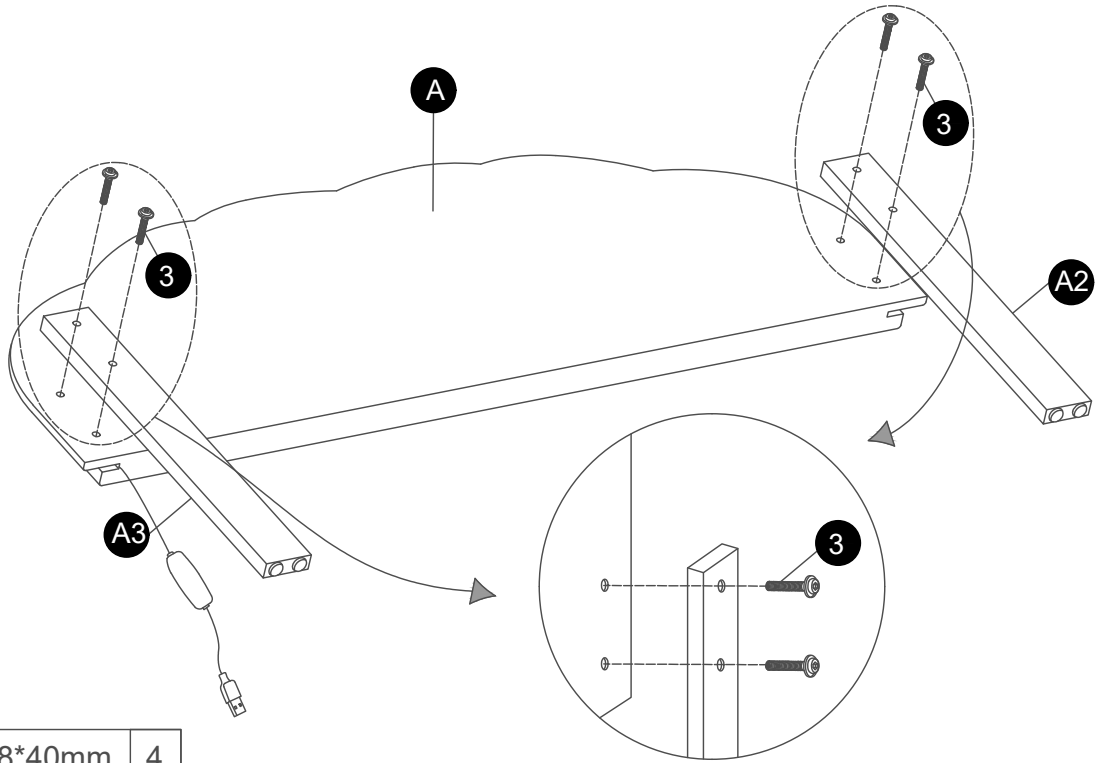

3	 M8*40mm	4
---	---	---

## Schritt 2

Left

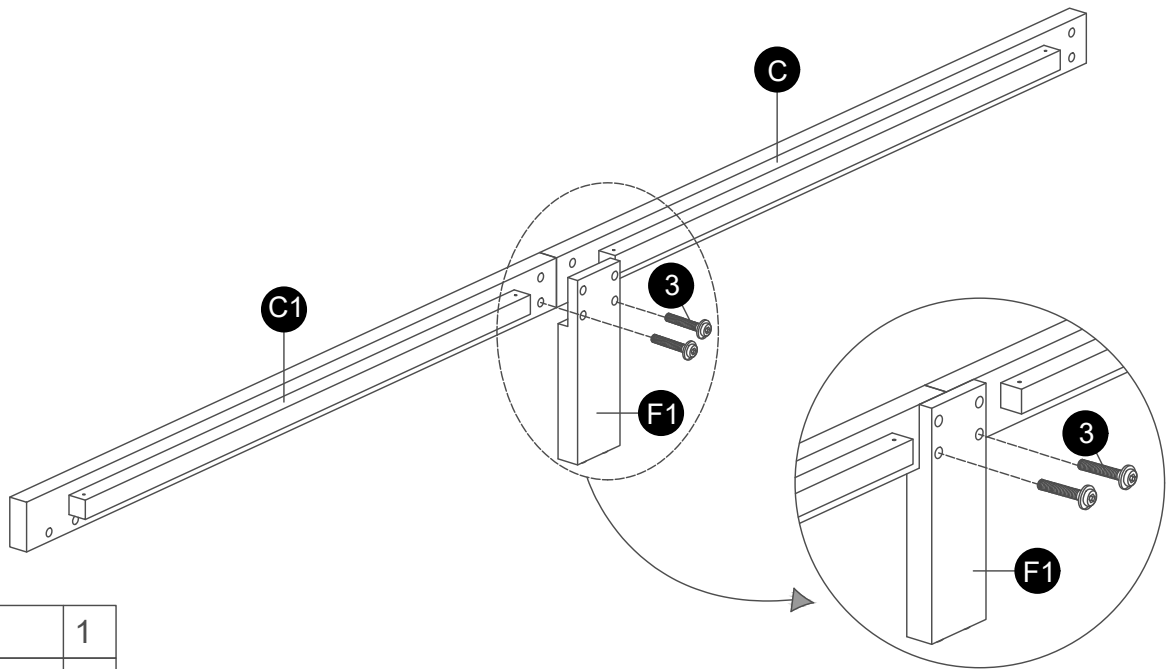

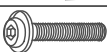

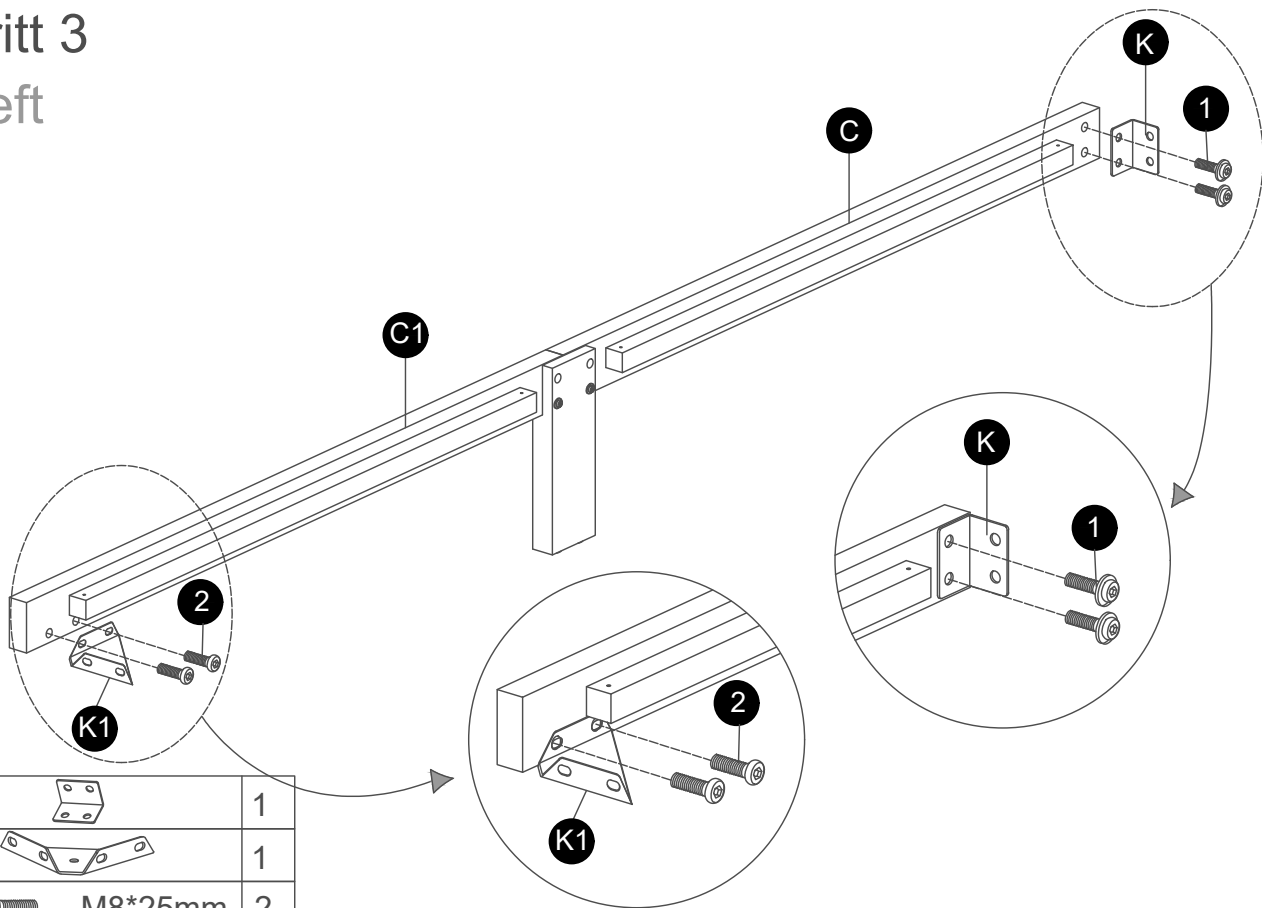

F1		1
3	 M8*40mm	2

# Schritt 3

Left





K		1
K1		1
1	 M8*25mm	2
2	 M8*25mm	2

# Schritt 4

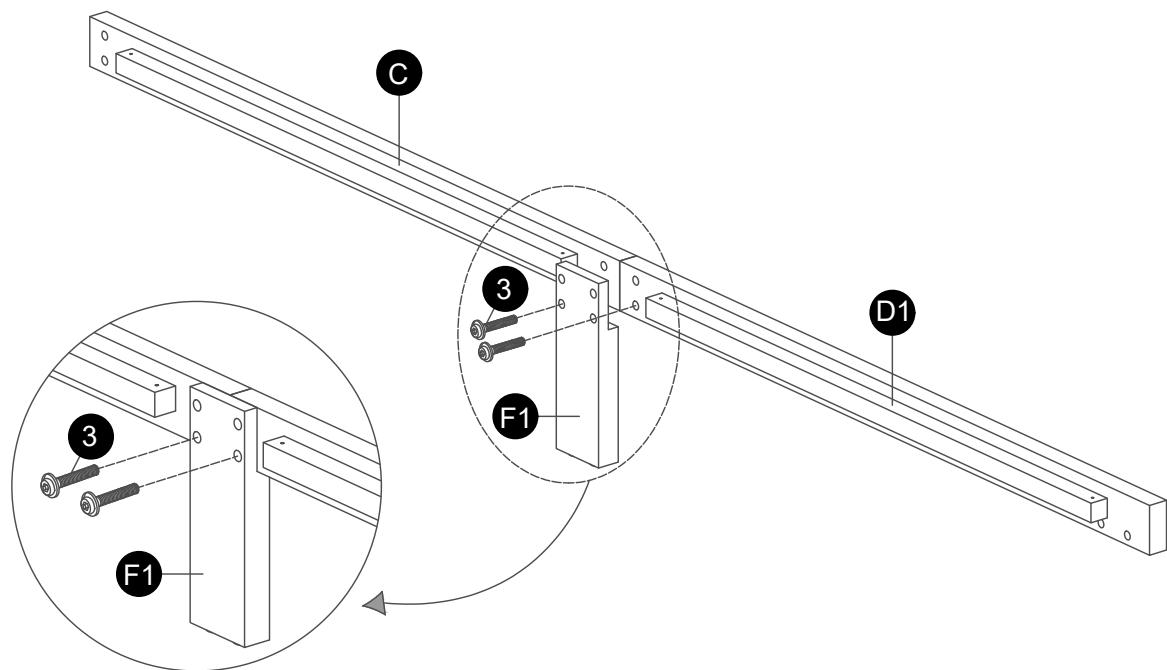
Right





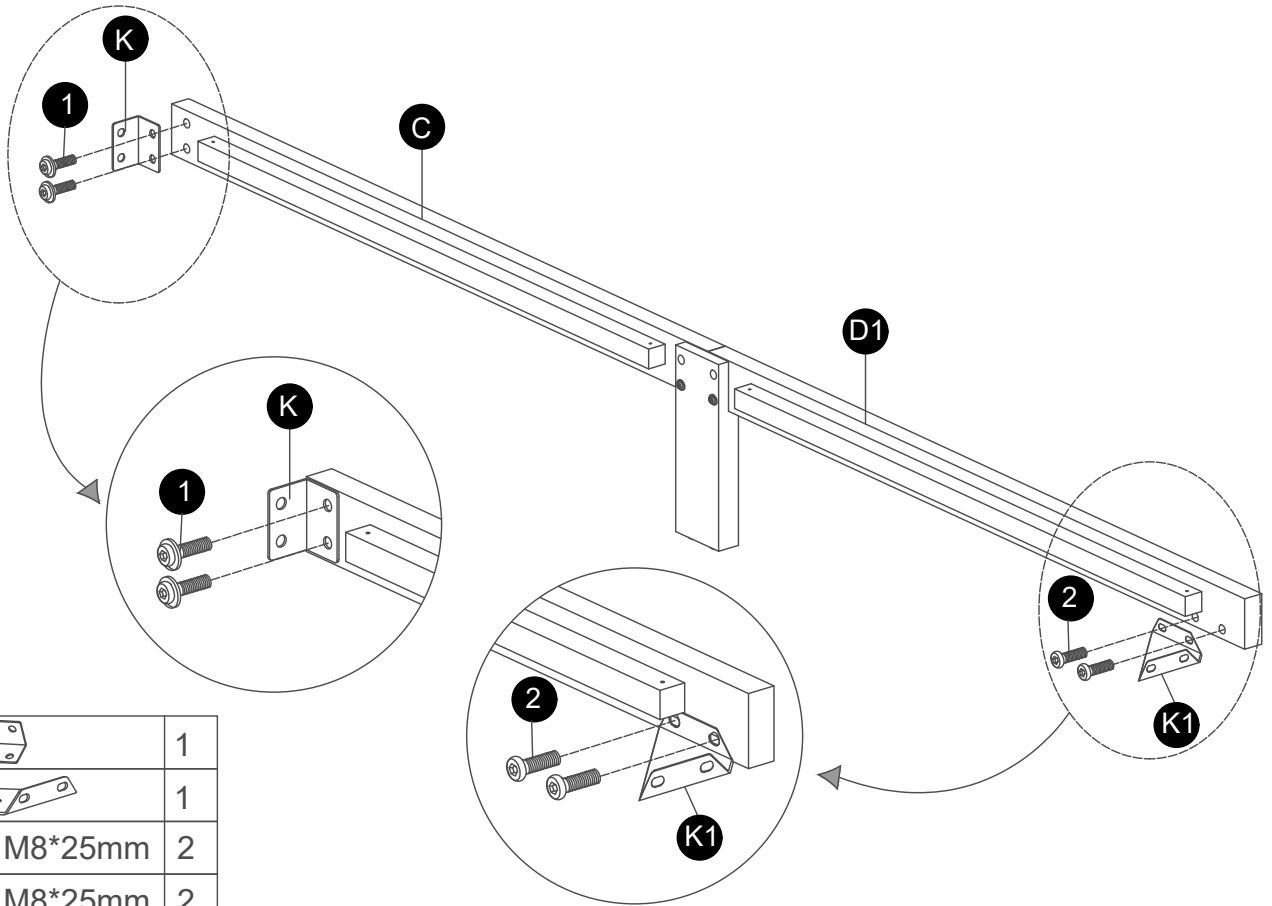

F1		1
3	 M8*40mm	2

# Schritt 5

Right



K		1
K1		1
1	 M8*25mm	2
2	 M8*25mm	2

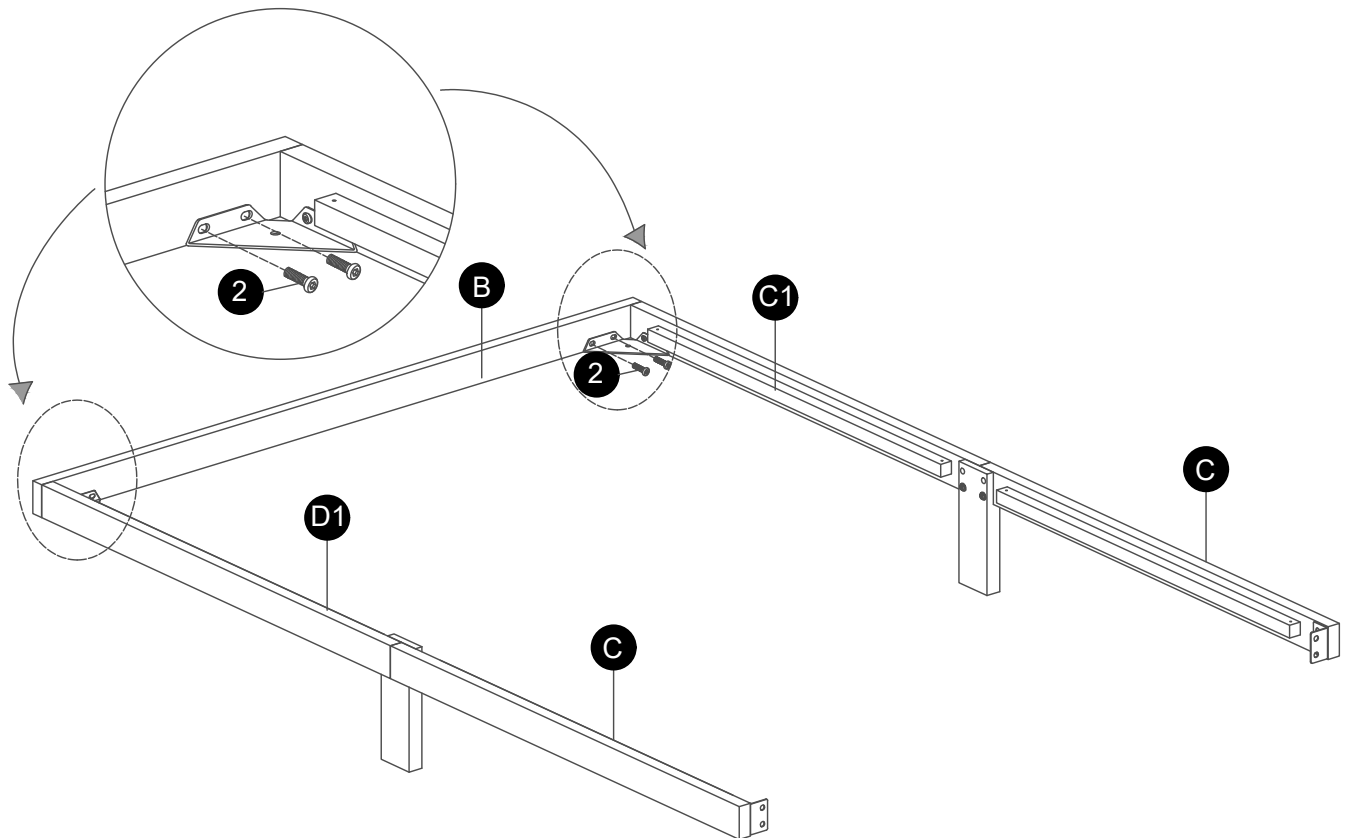

# Schritt 6

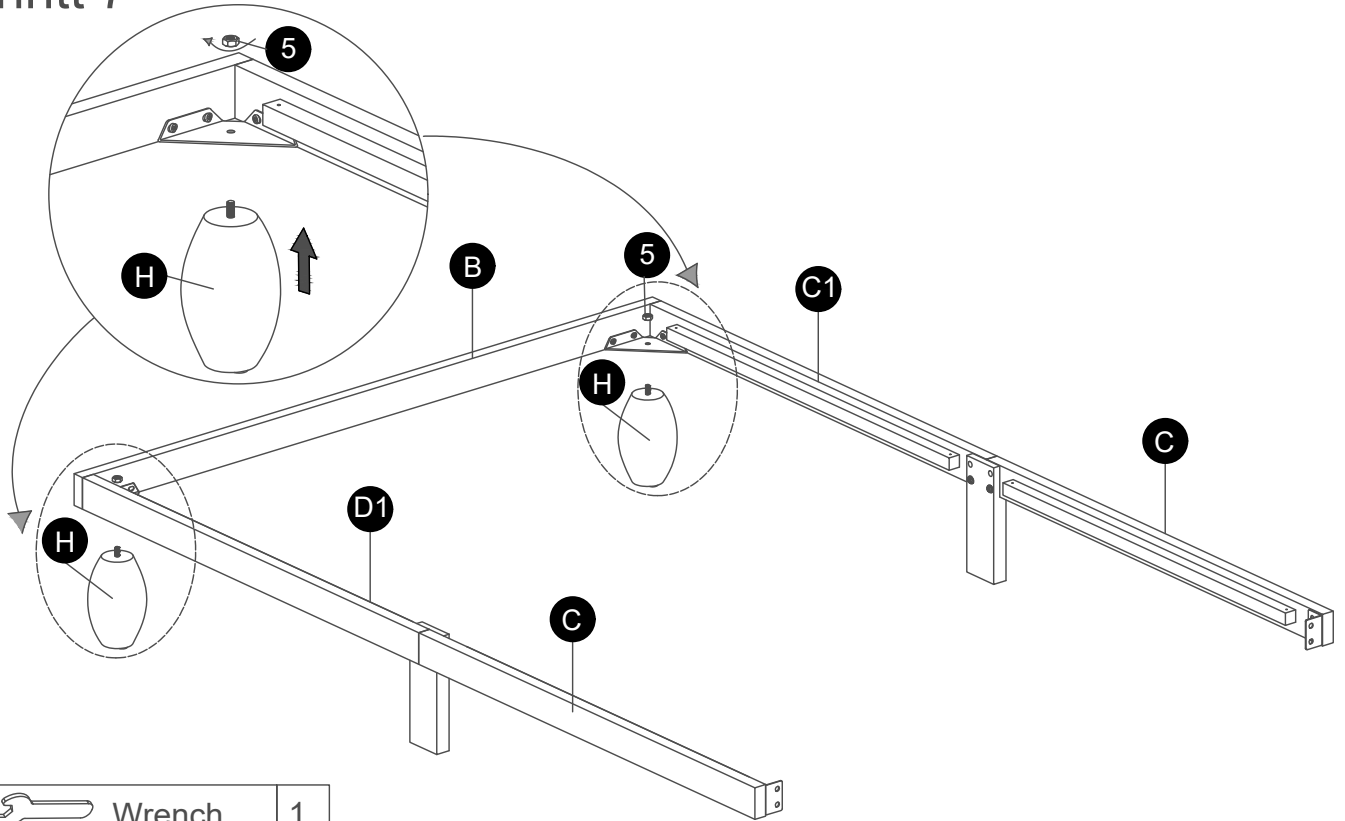

2	 M8*25mm	4
---	---	---

## Schritt 7



8		Wrench	1
H			2
5		M8*6	2

## Schritt 8

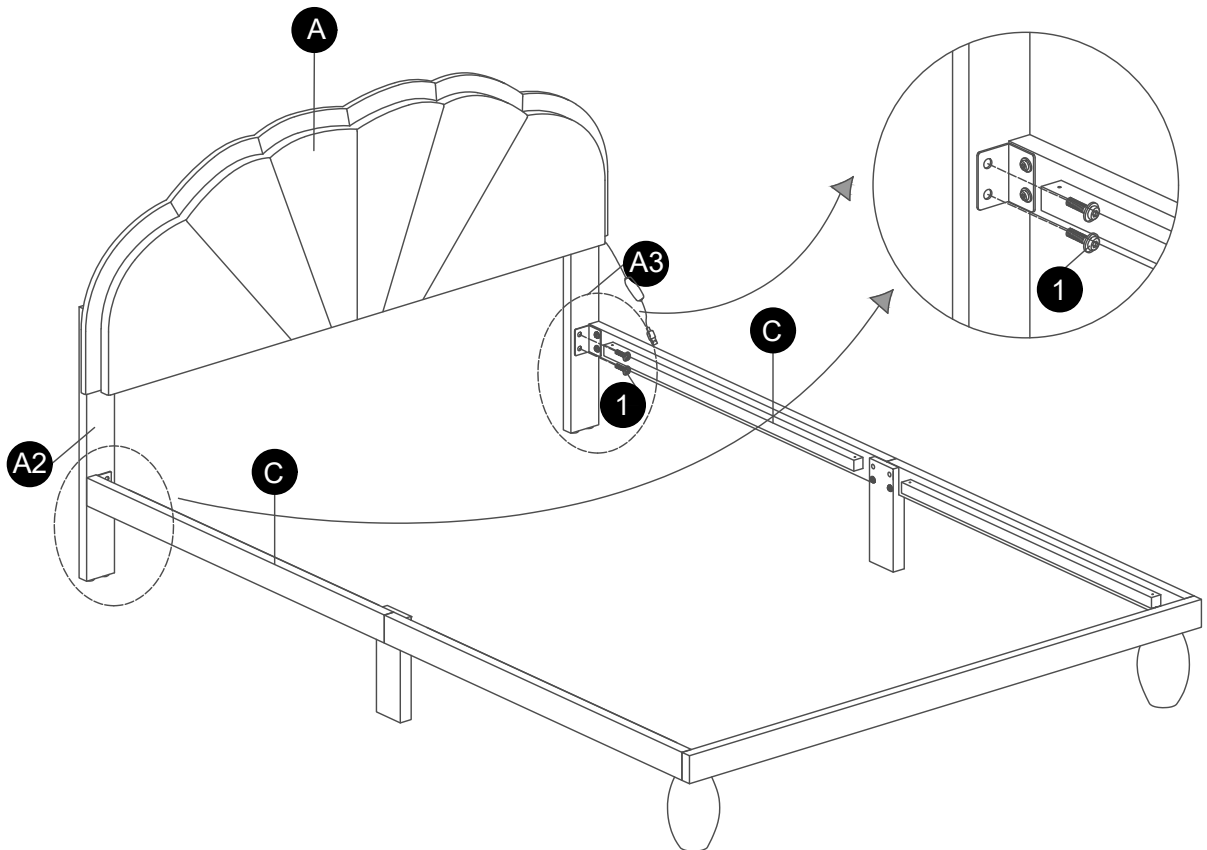

1		M8*25mm	4
---	---	---------	---

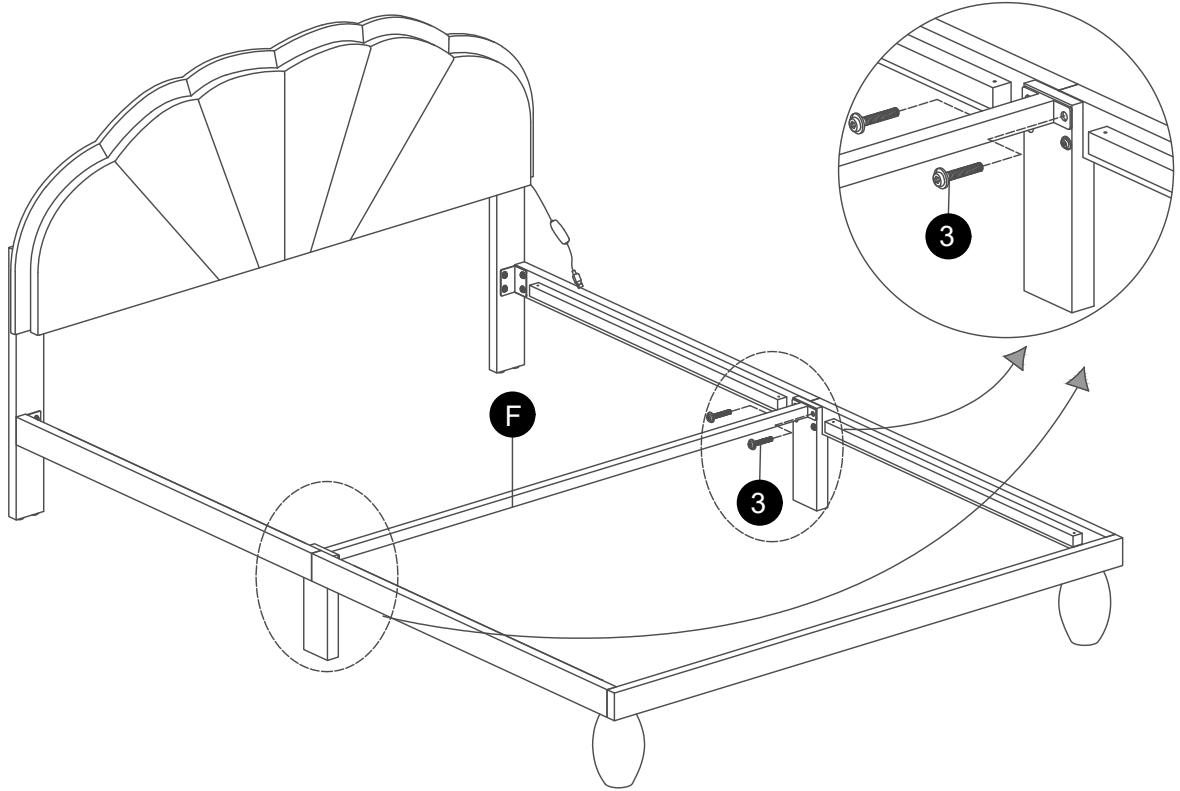

# Schritt 9

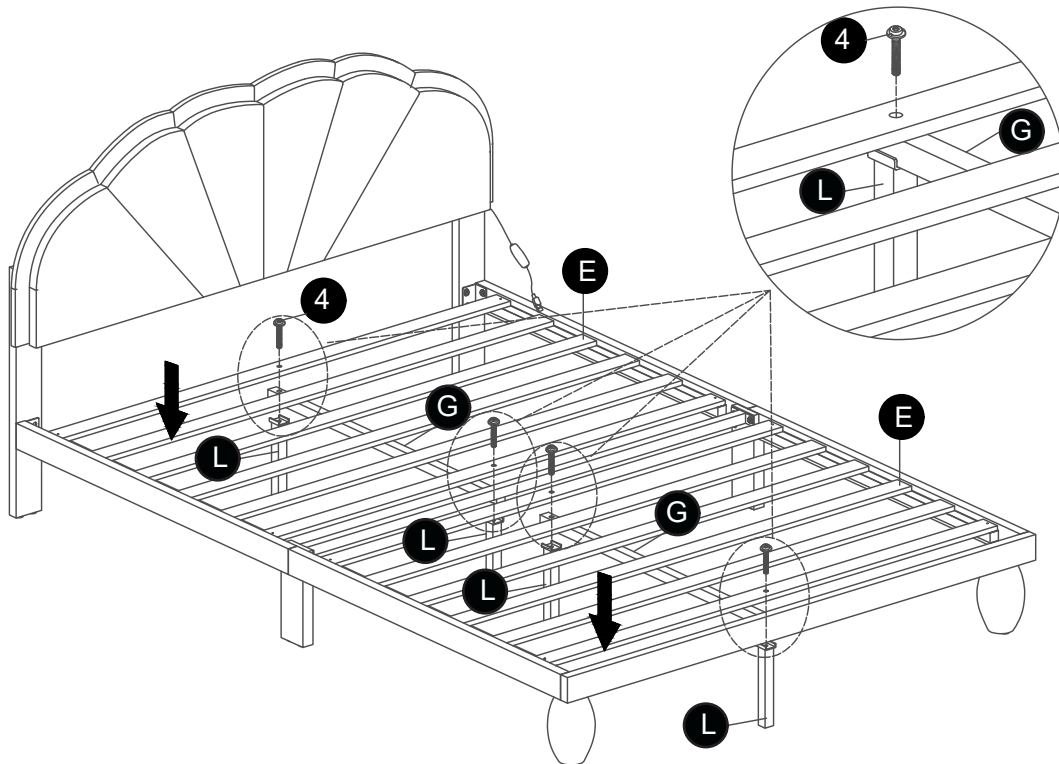

3	 M8*40mm	4
---	---	---

# Schritt 10

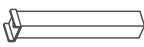

L		4
4	 M8*50mm	4

# Schritt 11

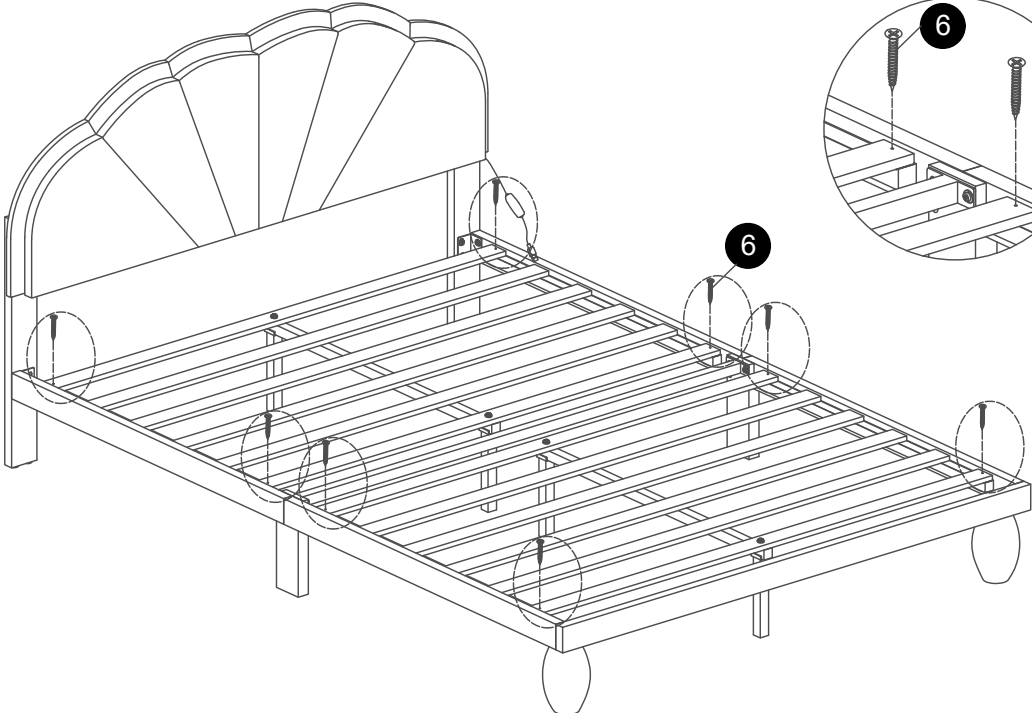

6		M4*30mm	8
---	---	---------	---

# Schritt 12

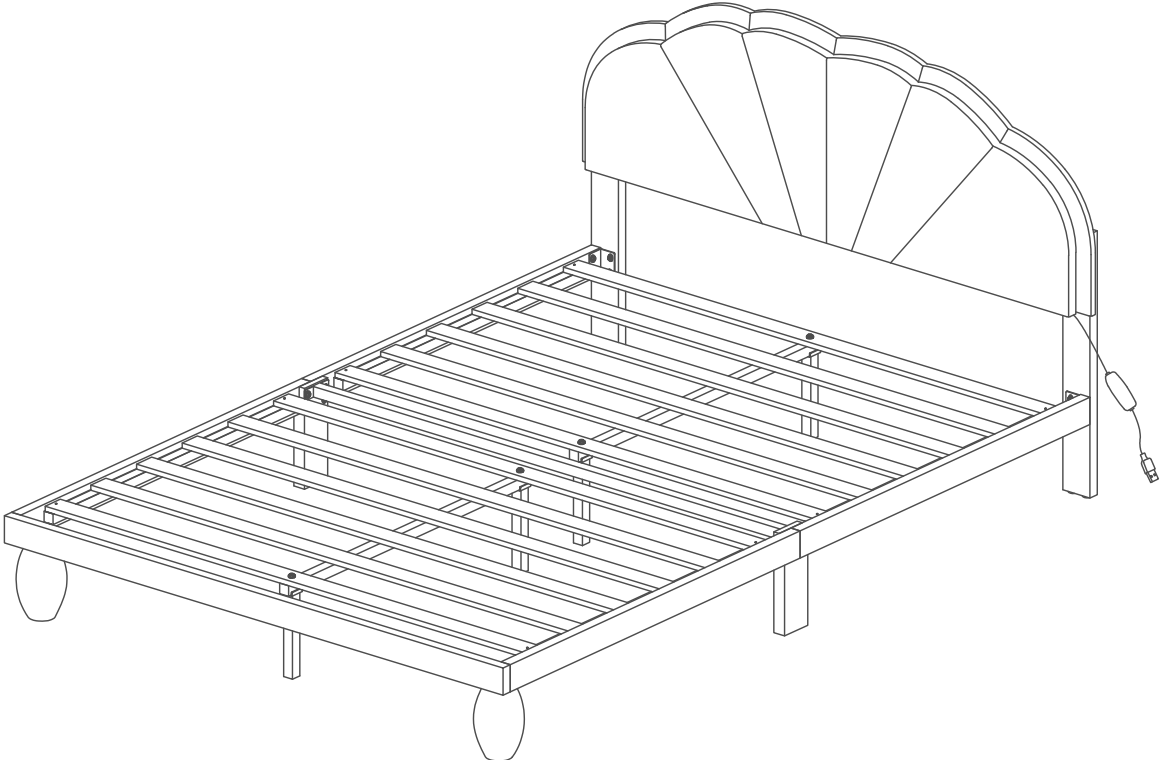

**DE:** Wenn Sie die Lichter nicht erfolgreich arbeiten lassen können, überprüfen Sie bitte die Folgendes:

1. Bitte überprüfen Sie die Fernbedienung. Sie müssen die Fernbedienung abreißen Plastikseptum vor Gebrauch.
2. Lassen Sie die Fernbedienung nicht zu weit vom Empfänger entfernt sein Es gibt kein Hindernis zwischen ihnen.
3. Bitte beachten Sie, dass die Fernbedienung für den Transport keine Batterien enthält. Das Batteriemodell lautet: CR2025

**FR:** Si vous ne parvenez pas à faire fonctionner les lumières correctement, veuillez vérifier les points suivants?:

1. Veuillez vérifier la télécommande. Vous devez retirer le septum en plastique de la télécommande avant utilisation.
2. Ne laissez pas la télécommande être trop éloignée du récepteur. Il n'y a aucun obstacle entre eux.
3. Veuillez noter que la télécommande ne contient pas de piles pour le transport. Le modèle de batterie est?: CR2025

**UK:** If you can't make the lights work successfully, please check the following:

1. Please check the remote control. You need to tear off the remote plastic septum before use.
2. Don't let the remote control be too far from the receiver There is no obstacle between them.
3. Please note that the remote control does not contain batteries for transportation. The battery model is: CR2025

NOTE: The battery in the remote control requires you to purchase and install it yourself.  
Model: CR2025 3. V

1



2

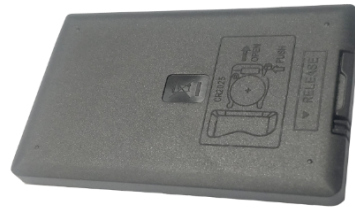

3

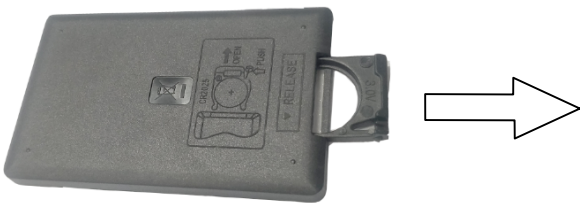

4



5

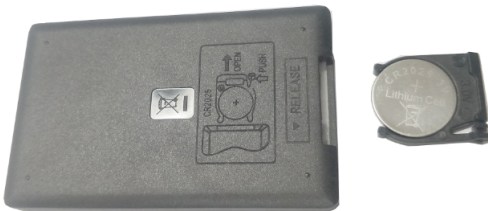

6

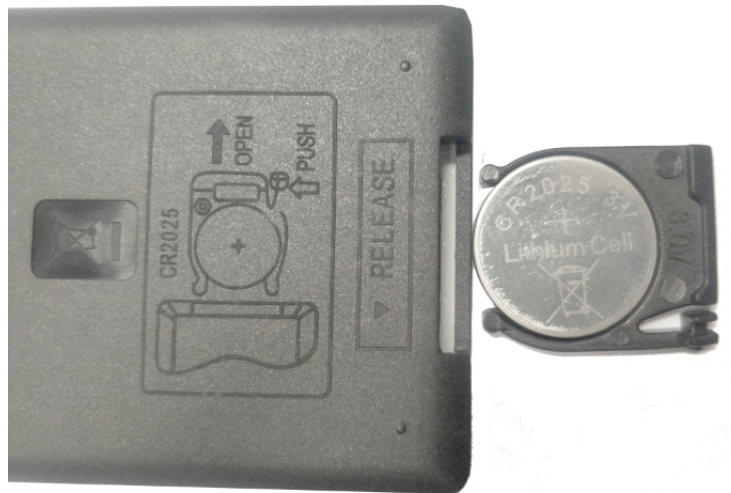

Modell : CR2025 3.V

7



8



# Certificate

Certificate Number: UNIA22022135EC-11



Product: Ultrathin cabinet light

Applicant: Foshan Wei Guang Te Lighting Technology Co.,Ltd.  
No.177, Bai'an South Road, Cangmen community Jun'an Town, Shunde District, Foshan City, Guangdong Province, China

Manufacturer: Foshan Wei Guang Te Lighting Technology Co.,Ltd.  
No.177, Bai'an South Road, Cangmen community Jun'an Town, Shunde District, Foshan City, Guangdong Province, China

Model No.: MD60, MD45, MD70, MD80

Trade Name: N/A

Test Methods: EN IEC 55015:2019/A11:2020  
EN 61547:2009

The laboratory tested the product provided by the applicant according to the above test methods. According to the test results, the product conforms to EMC Directive (2014/30/EU) issued by the European Commission. It is possible to use CE marking to demonstrate the compliance with EMC Directive.

The certificate applies to the tested sample above mentioned only and shall not imply an assessment of the whole production. It is only valid in connection with the test report number: UNIA22022135ER-11.

Mar. 04, 2022  
Issue Date

  
Hoffer Lau



## Shenzhen United Testing Technology Co., Ltd.

Shenzhen: 2/F., Annex Building, Jiahuangyuan Tech Park, No.365, Baotian 1st Road, Tiegang, Xixiang Street, Bao'an District, Shenzhen, Guangdong, China/518050

Guangzhou: No.47-3, Industrial Road, Zhushan, Dalong Street, Panyu District, Guangzhou, Guangdong, China/511450

Tel: +86-755-86180996 / +86-020-39277769 Fax: +86-0755-86180156

Web Site: [www.uni-lab.hk/](http://www.uni-lab.hk/) E-mail: [hofferlau@uni-lab.hk](mailto:hofferlau@uni-lab.hk)



Certificate of Compliance