

Installation sanleitung Installation Instruction Instruction d'installation

SKUNUMBER:

N636P369110

N636P369111

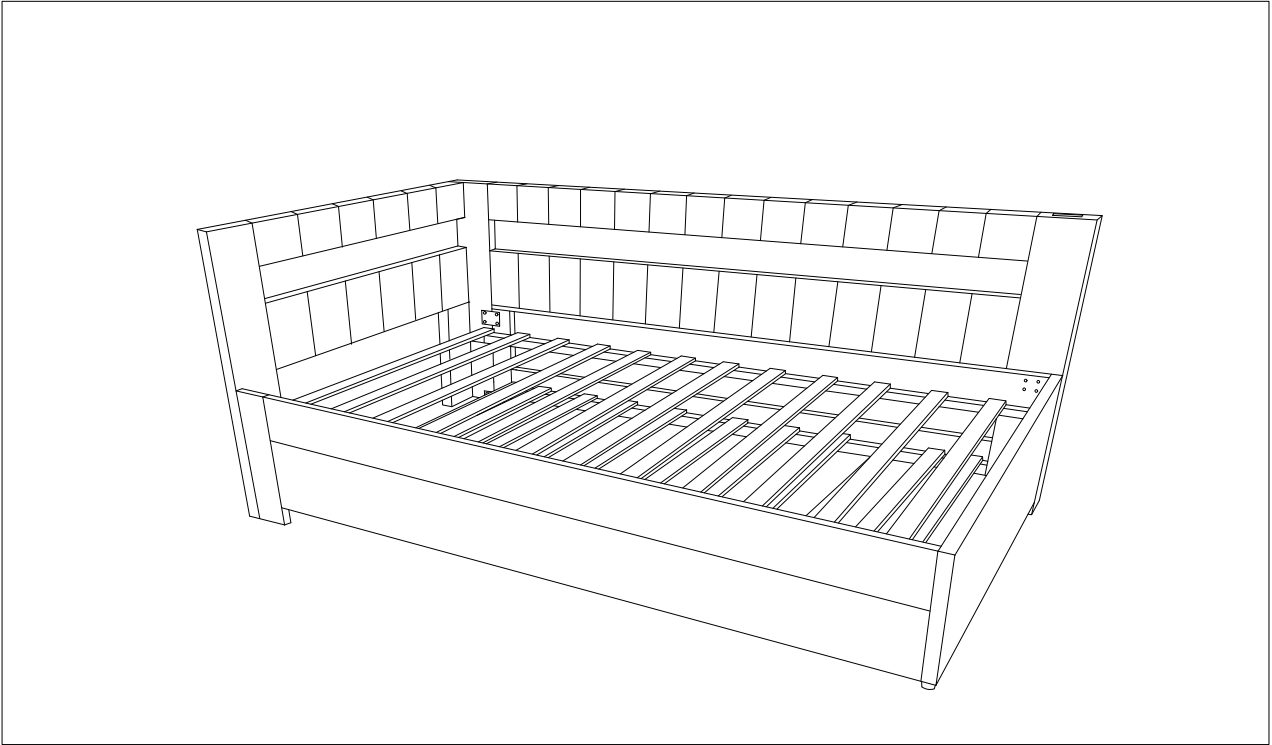

DE Unser Produkt wird Ihnen in 2 Paketen geliefert. Die Lieferzeiten dieser 2 Pakete können abweichen, bitte haben Sie etwas Geduld und vielen Dank für Ihr Verständnis.

UK Our product will be delivered to you in 2 packages. The delivery times of these 2 packages may differ, please be patient and thank you for your understanding.

FR Notre produit vous sera livré en 2 colis. Les délais de livraison de ces 2 colis peuvent différer, soyez patient et merci pour votre compréhension.



Points de collecte sur www.quefairemesdechets.fr
Privilégiez la réparation ou le don de votre appareil !

DE: Vor dem Einbau die Schrauben in die Löcher stecken und festziehen, aber nicht bis 100%, 70% bis 80% anziehen reicht aus. Schließlich, nachdem alle Schrauben installiert sind, ziehen Sie alle Schrauben auf 100%. Wenn Sie auf diese Probleme stoßen, wie z. B. Fehlausrichtung der Löcher oder Unfähigkeit, bestimmte Teile zu installieren, überprüfen Sie bitte, ob die Schrauben korrekt verwendet werden und passen Sie die Dichtigkeit der Schrauben an.

UK: Before installation, insert the screws into the holes and tighten them, but do not tighten them to 100%, 70% to 80% is sufficient. Finally, after all screws are installed, tighten all screws to 100%. If you encounter these issues, such as if the holes cannot be aligned or some parts cannot be installed, please check if the screws are used correctly and adjust the tightness of the screws.

FR: Insérer la vis dans le trou avant la fin de l'assemblage, serrer la vis, mais ne pas serrer à 100%, 70% ~ 80% est correct. Enfin, une fois que toutes les vis sont bien serrées, toutes les vis sont serrées à 100%. Si vous rencontrez ces problèmes, par exemple si les trous ne sont pas alignés ou si certaines pièces ne peuvent pas être montées, vérifiez que les vis sont utilisées correctement et Ajustez leur serrage.

English

IMPORTANT ! KEEP FOR FUTURE REFERENCE : READ CAREFULLY

- To be assembled by an adult. Assembly must be checked by an adult before use
- WARNING ! Keep all screws, small parts and plastic bags out of the reach of children
- Properly identify all parts before assembling
- Never use your item if any of its parts are broken or missing
- Should any problems arise, please contact our After Sales Service
- Manufacturer's instructions shall be followed at all times
- Care: Clean with a soft, dry cloth. In case of larger stains, carefully rub with a slightly damp, non-abrasive sponge
- Avoid the risk of fire by not placing furniture near sources of ignition or hot items
- Do not jump on the bed

Deutsch

WICHTIG ! ZUM SPÄTEREN NACHSCHLAGEN AUFBEWAHREN: SORGFÄLTIG LESEN

- Muss von einem Erwachsenen zusammengebaut werden. Der Zusammenbau muss vor dem Gebrauch von einem Erwachsenen überprüft werden
- WARNUNG! Bewahren Sie alle Schrauben, Kleinteile und Plastikbeutel außerhalb der Reichweite von Kindern auf
- Kennzeichnen Sie vor dem Zusammenbau alle Teile richtig
- Benutzen Sie Ihren Artikel niemals, wenn Teile gebrochen sind oder fehlen
- Sollten Probleme auftreten, wenden Sie sich bitte an unseren Kundendienst
- Die Anweisungen des Herstellers sind stets zu befolgen
- Pflege: Mit einem weichen, trockenen Tuch reinigen. Bei größeren Flecken vorsichtig mit einem leicht feuchten, nicht scheuernden Schwamm abreiben. nicht scheuernden Schwamm
- Vermeiden Sie die Gefahr eines Brandes, indem Sie die Möbel nicht in der Nähe von Zündquellen oder heißen Gegenständen aufstellen
- Nicht auf das Bett springen

Français

IMPORTANT ! CONSERVER POUR RÉFÉRENCE ULTÉRIEURE : LIRE ATTENTIVEMENT

- Le montage doit être effectué par un adulte. Le montage doit être vérifié par un adulte avant Utilisation
- ATTENTION ! Tenir les vis, les petites pièces et les sachets en plastique hors de portée des enfants
- Identifiez correctement toutes les pièces avant de les assembler
- N'utilisez jamais votre article si l'une de ses pièces est cassée ou manquante
- En cas de problème, veuillez contacter notre service après-vente
- Les instructions du fabricant doivent être respectées à tout moment
- Entretien : nettoyer avec un chiffon doux et sec. En cas de taches plus importantes, frotter soigneusement avec une éponge non abrasive légèrement humide. légèrement humide et non Abrasive
- Évitez les risques d'incendie en ne plaçant pas les meubles à proximité de sources d'inflammation ou d'objets chauds
- Ne pas sauter sur le lit

Italiano

IMPORTANTE! CONSERVARE PER RIFERIMENTO FUTURO: LEGGERE ATTENTAMENTE

- Deve essere assemblato da un adulto. L'assemblaggio deve essere controllato da un adulto prima dell'uso
- **ATTENZIONE!** Tenere tutte le viti, le piccole parti e i sacchetti di plastica fuori dalla portata dei bambini
- Identificare correttamente tutte le parti prima dell'assemblaggio
- Non utilizzare mai l'articolo se alcune parti sono rotte o mancanti
- In caso di problemi, si prega di contattare il nostro Servizio Post Vendita
- Le istruzioni del produttore devono essere sempre seguite
- Cura: Pulire con un panno morbido e asciutto. In caso di macchie più estese, strofinare accuratamente con una spugna leggermente umida e non abrasiva
- Evitare il rischio di incendio, non collocando i mobili vicino a fonti di accensione o a oggetti caldi
- Non saltare sul letto

Español

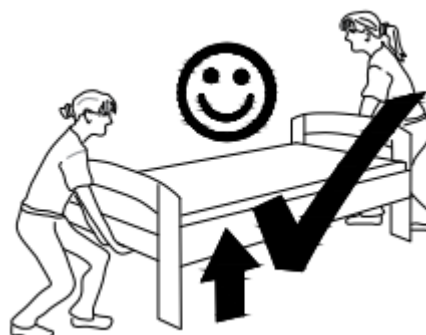
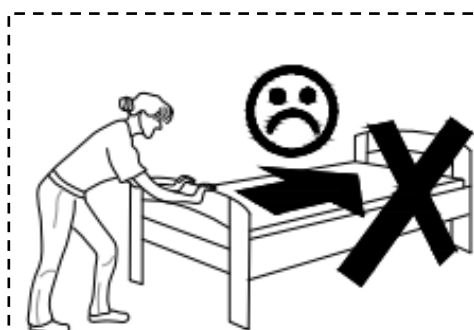

¡ IMPORTANTE ! CONSERVELO PARA FUTURAS CONSULTAS: LEA ATENTAMENTE

- Debe ser montado por un adulto. El montaje debe ser comprobado por un adulto antes del uso
- ADVERTENCIA Mantenga todos los tornillos, piezas pequeñas y bolsas de plástico fuera del alcance de los niños.
- Identifique correctamente todas las piezas antes de montarlas
 - Nunca utilice su artículo si alguna de sus piezas está rota o falta
 - Si surge algún problema, póngase en contacto con nuestro Servicio Postventa
 - Las instrucciones del fabricante deben seguirse en todo momento
 - Cuidado: Limpiar con un paño suave y seco. En caso de manchas más grandes, frote cuidadosamente con una esponja no abrasiva ligeramente humedecida.
 - Evite el riesgo de incendio no colocando los muebles cerca de fuentes de ignición u objetos calientes.
 - No saltar sobre la cama.

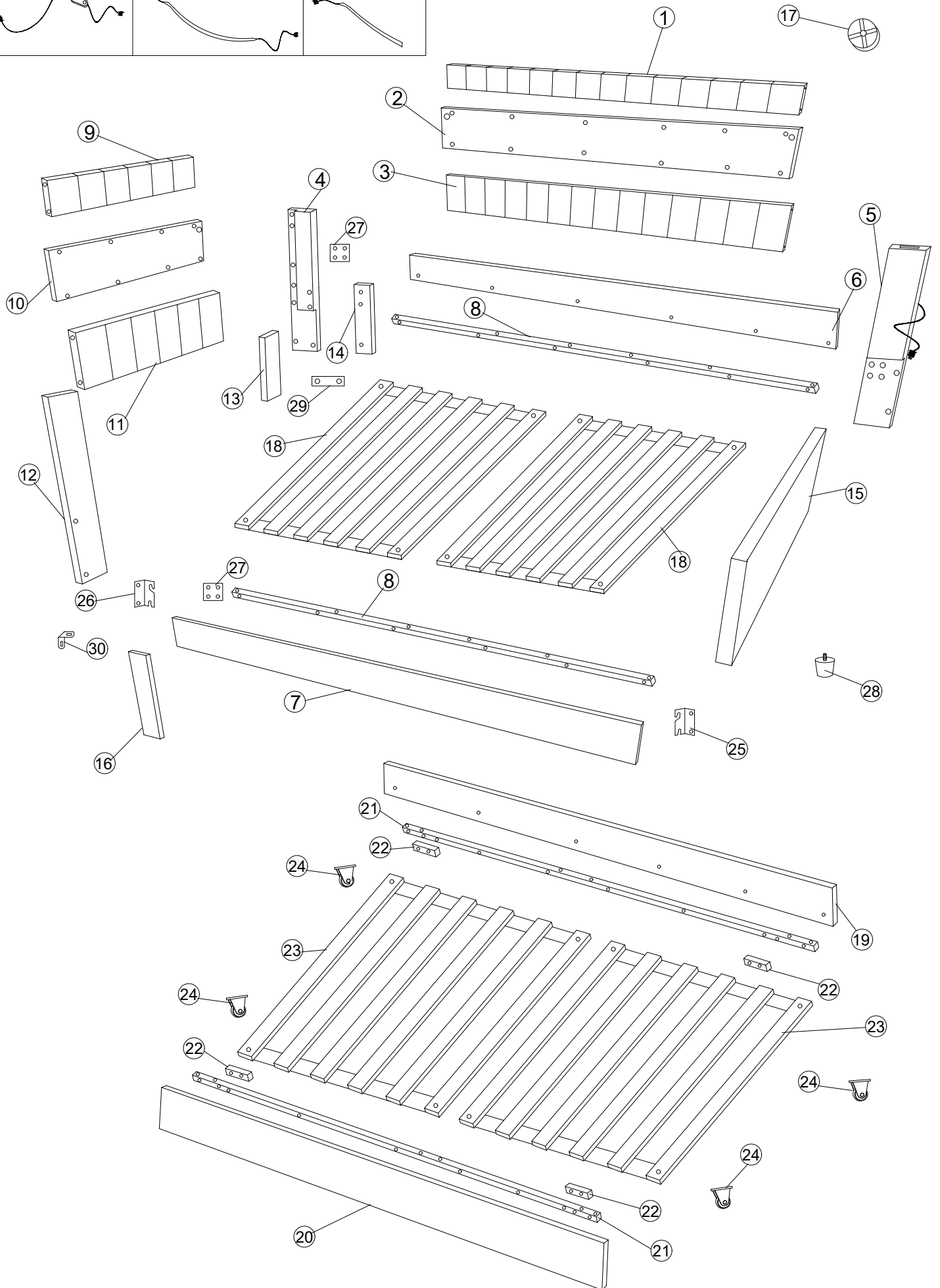
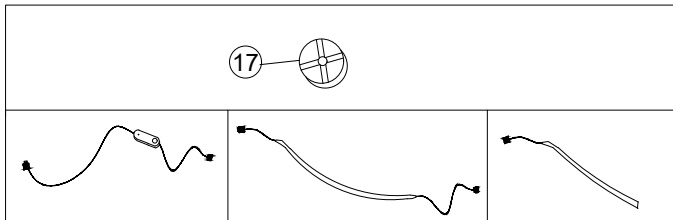



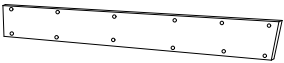
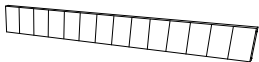

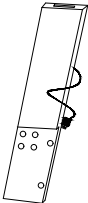
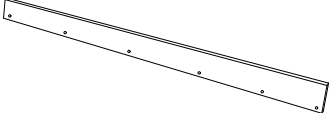
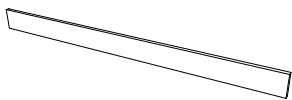
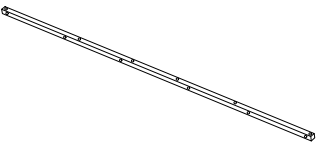
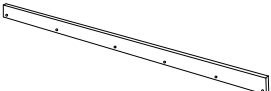
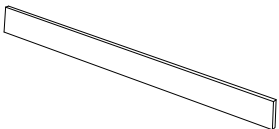
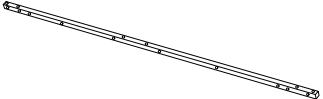

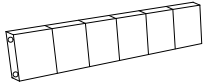
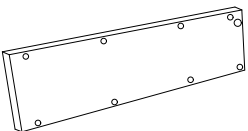

Part List/ Teilleiste/ Liste des pièces
N636P369110

1		×1	2		×1
3		×1	4		×1
5		×1	6		×1
7		×1	8		×2
19		×1	20		×1
21		×2			

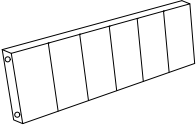
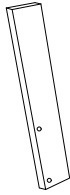

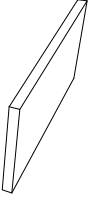
Part List/ Teilleiste/ Liste des pièces
N636P369111

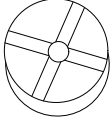
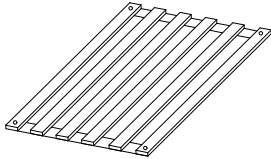
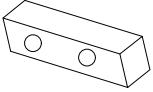
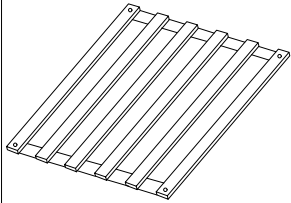
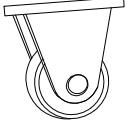
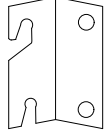
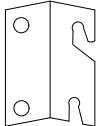
9		×1	10		×1
---	---	----	----	---	----

Part List/ Teileliste/ Liste des pièces
N636P369111

11		x1	12		x1
13		x1	14		x1
15		x1	16		x1
17		x1	18		x2
22		x4	23		x2
24		x4	25		x1
26		x1	27		x2

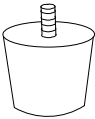
Part List/ Teileliste/ Liste des pièces
N636P369111

28		×1	29		×1
30		×1			

Hardware List/ Hardware-Liste/ Liste du matériel
N636P369111

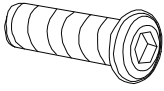
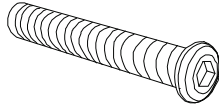
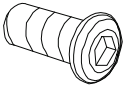
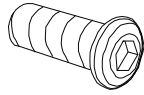
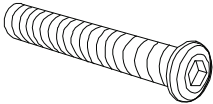
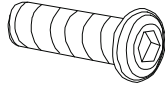
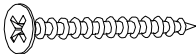
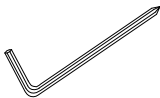
A	 M8*40MM	×19	B	 M8*55MM	×8
C	 M6*16MM	×20	D	 M8*20MM	×10
E	 M8*47MM	×34	F	 M8*32MM	×21
G	 φ3*20	×16	H		×1

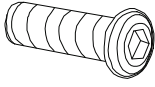
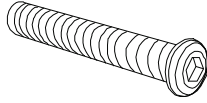
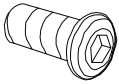
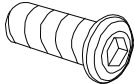
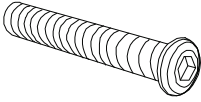
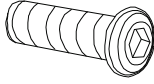
<p style="text-align: center;">A</p>	 <p style="text-align: center;">M8*40MM</p>	<p style="text-align: center;">×19</p>	<p style="text-align: center;">B</p>	 <p style="text-align: center;">M8*55MM</p>	<p style="text-align: center;">×8</p>
<p style="text-align: center;">C</p>	 <p style="text-align: center;">M6*16MM</p>	<p style="text-align: center;">×20</p>	<p style="text-align: center;">D</p>	 <p style="text-align: center;">M8*20MM</p>	<p style="text-align: center;">×10</p>
<p style="text-align: center;">E</p>	 <p style="text-align: center;">M8*47MM</p>	<p style="text-align: center;">×34</p>	<p style="text-align: center;">F</p>	 <p style="text-align: center;">M8*32MM</p>	<p style="text-align: center;">×21</p>

DE:Bitte beachten Sie, dass die Formen der Schrauben A und B und C und D und E und F ähnlich sind. Bitte installieren Sie entsprechend der Anleitung und unterscheiden Sie sie!

UK:Please note that the shapes of screws A and B and C and D and E and F are similar. Please install according to the instructions and distinguish them!

FR:Notez que les vis A et B et C et D et E et F ont des formes similaires. Veuillez les installer en suivant les instructions pour les séparer!

1

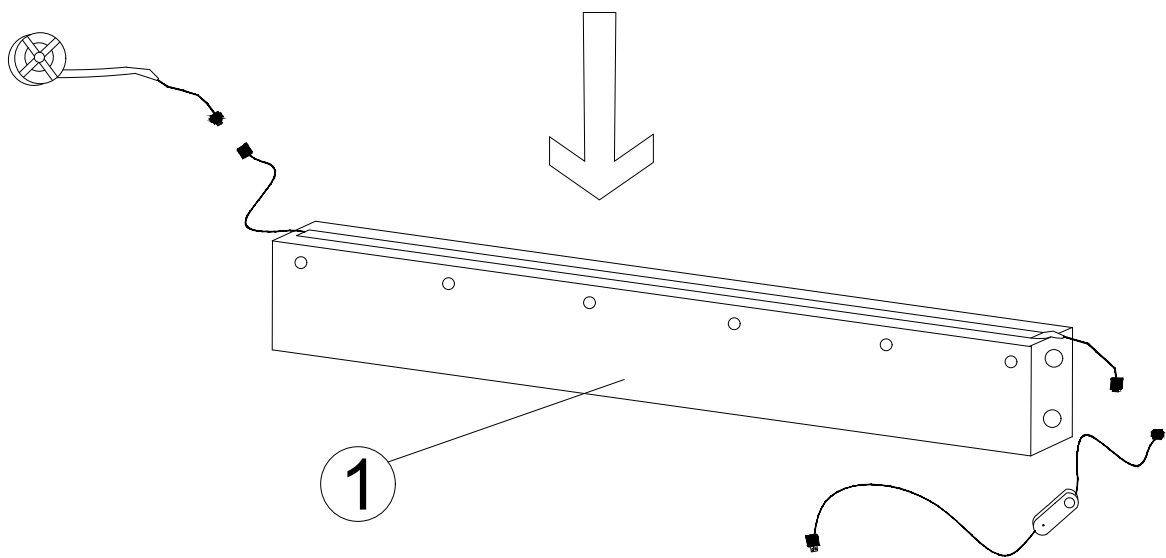
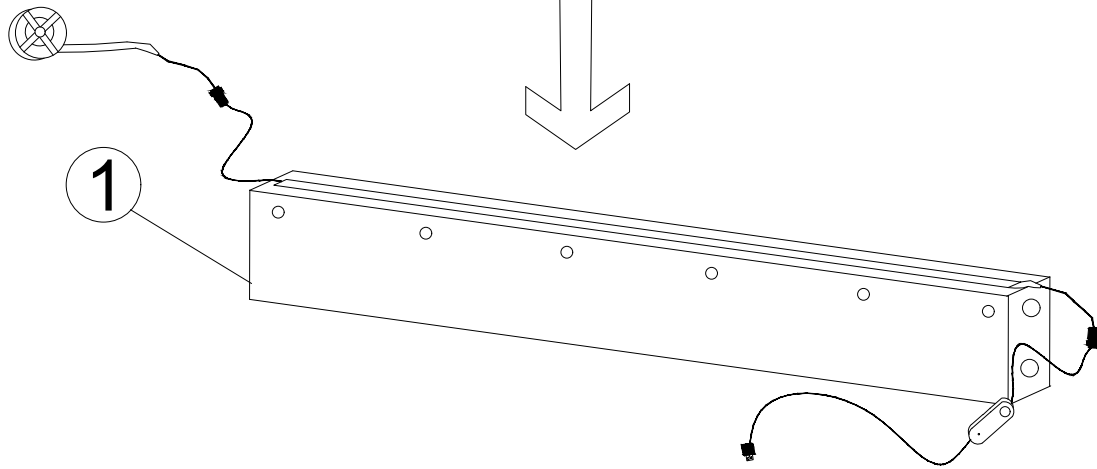
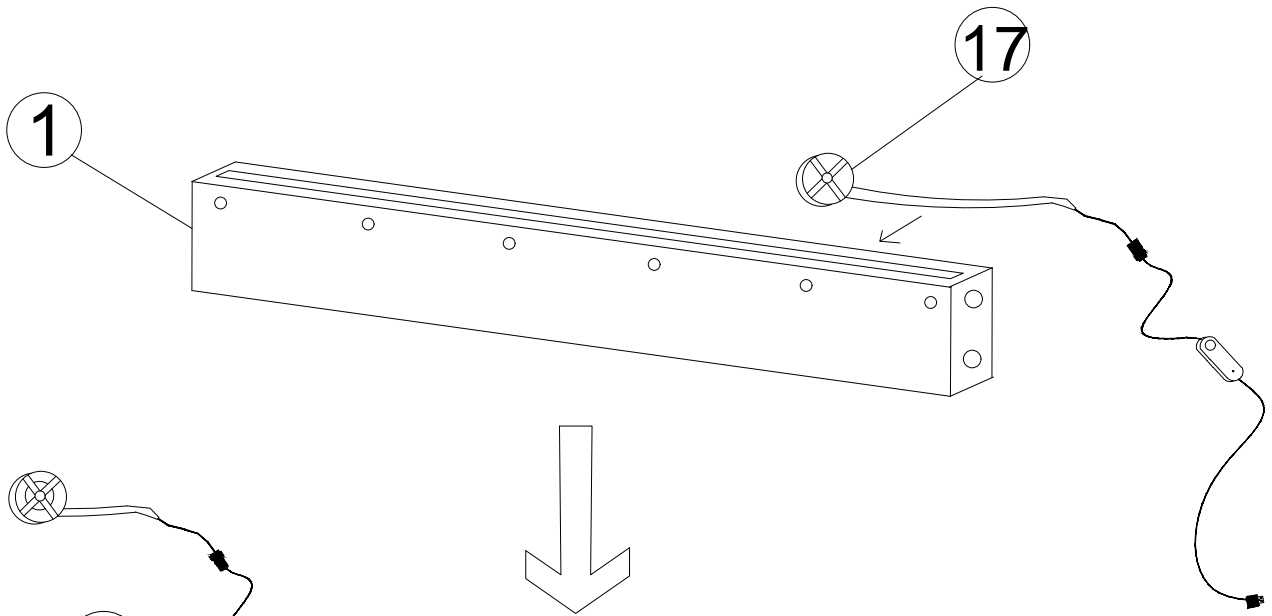

2

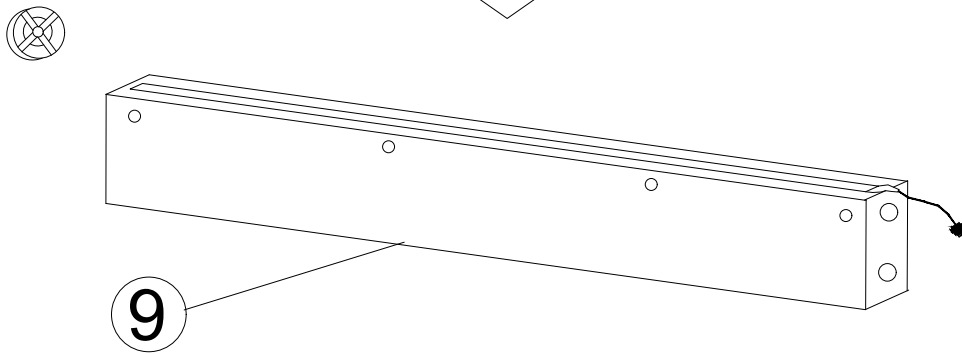
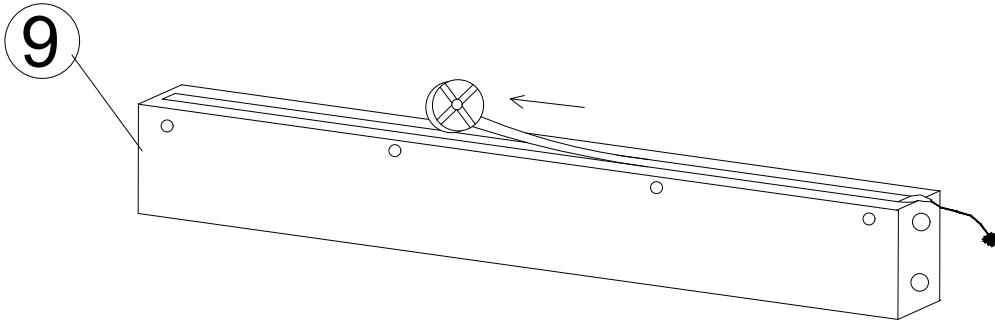
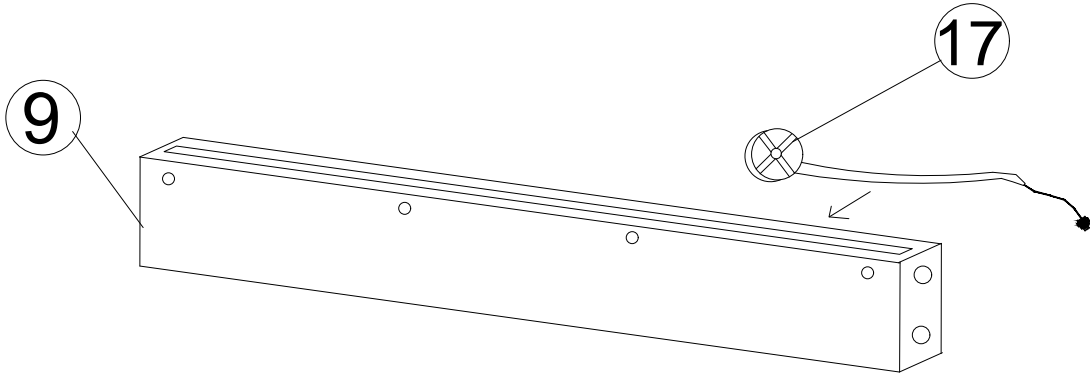

3

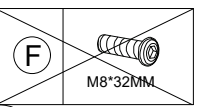
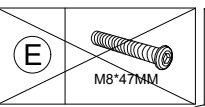
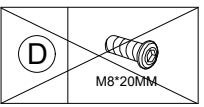
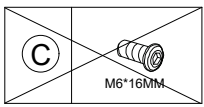
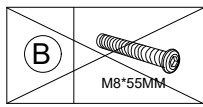

M8*40MM
A×8PCS

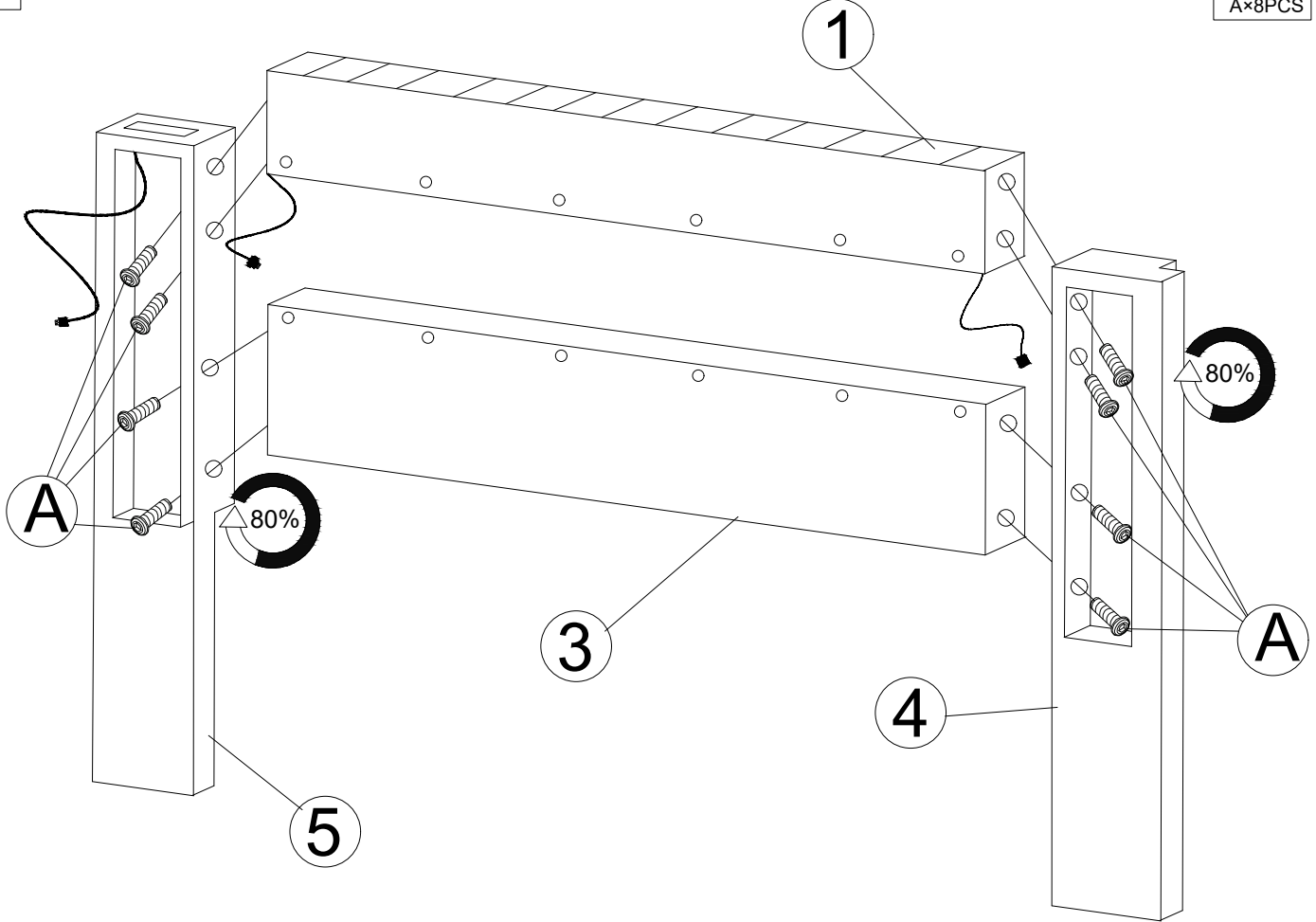

4

M6*16MM
C×12PCS

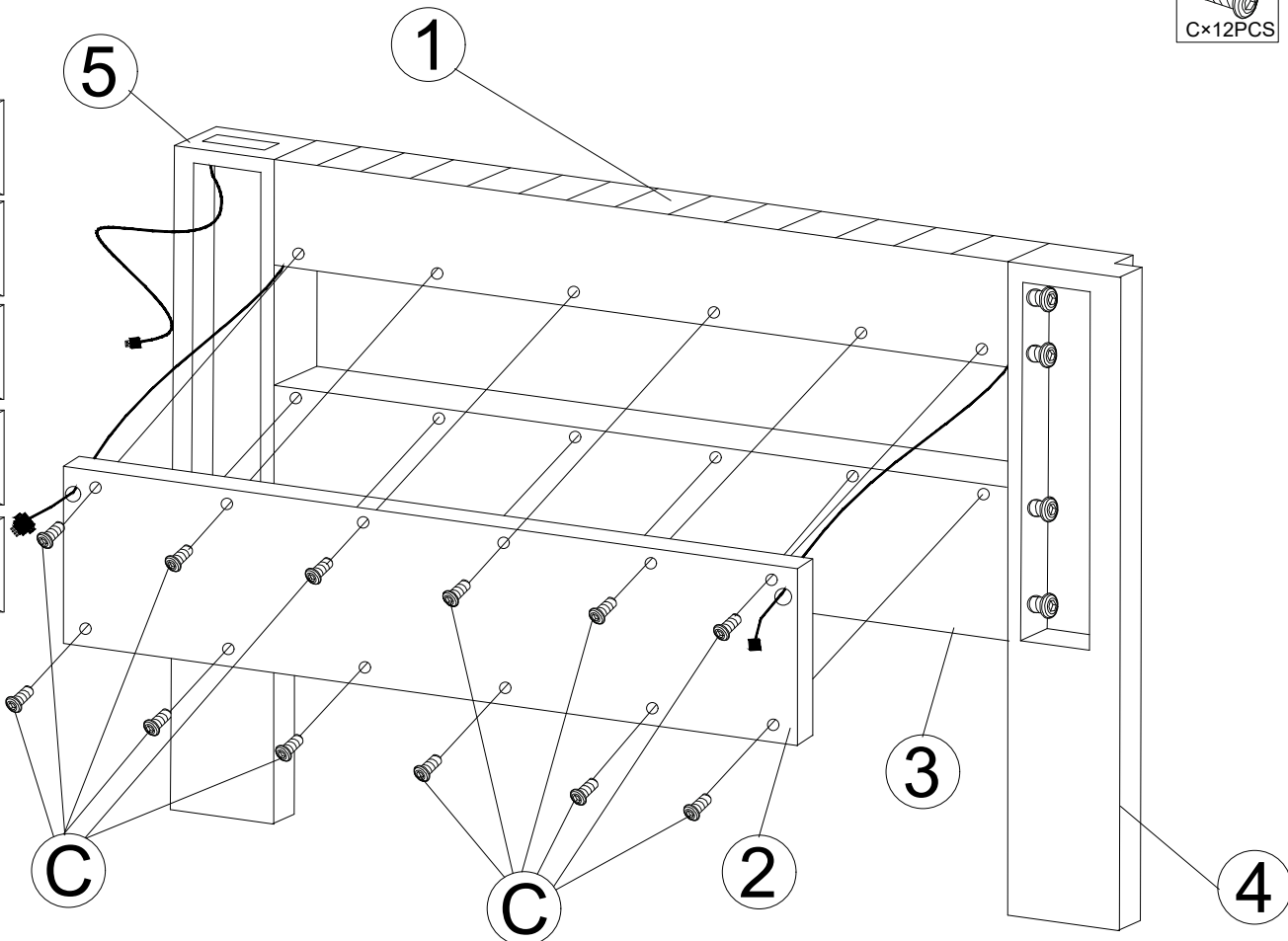
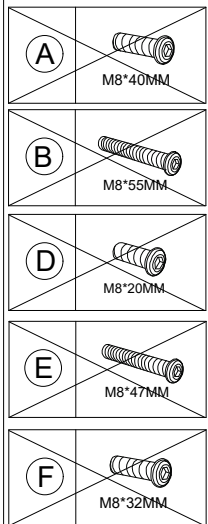

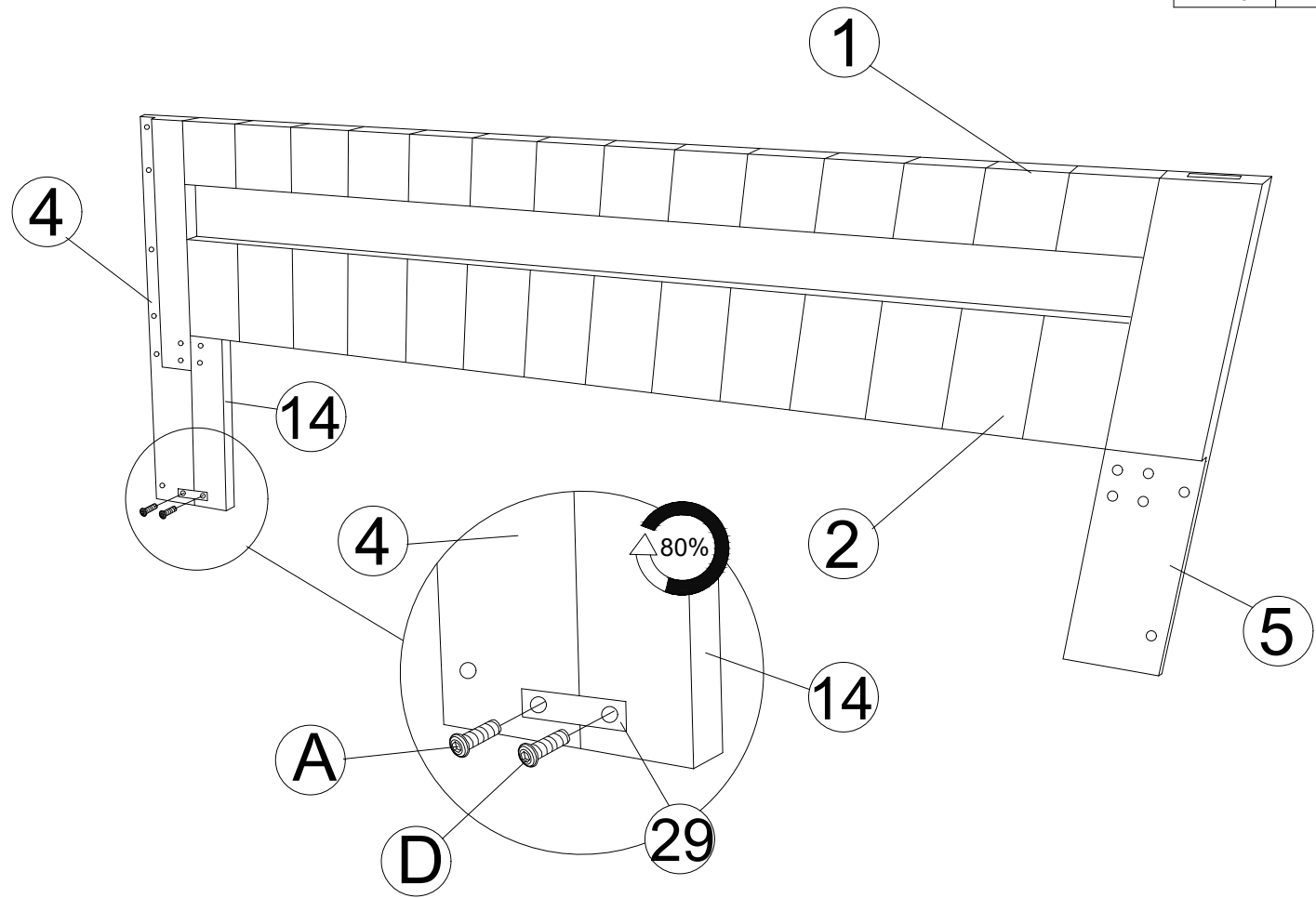
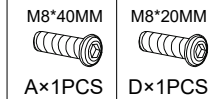
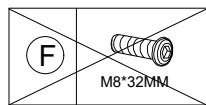
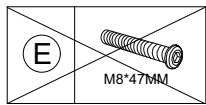
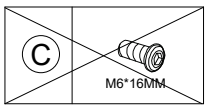
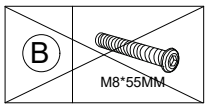

5

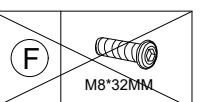
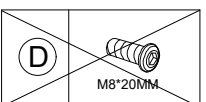
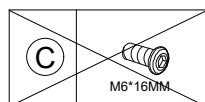
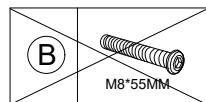
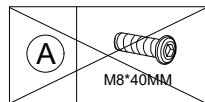
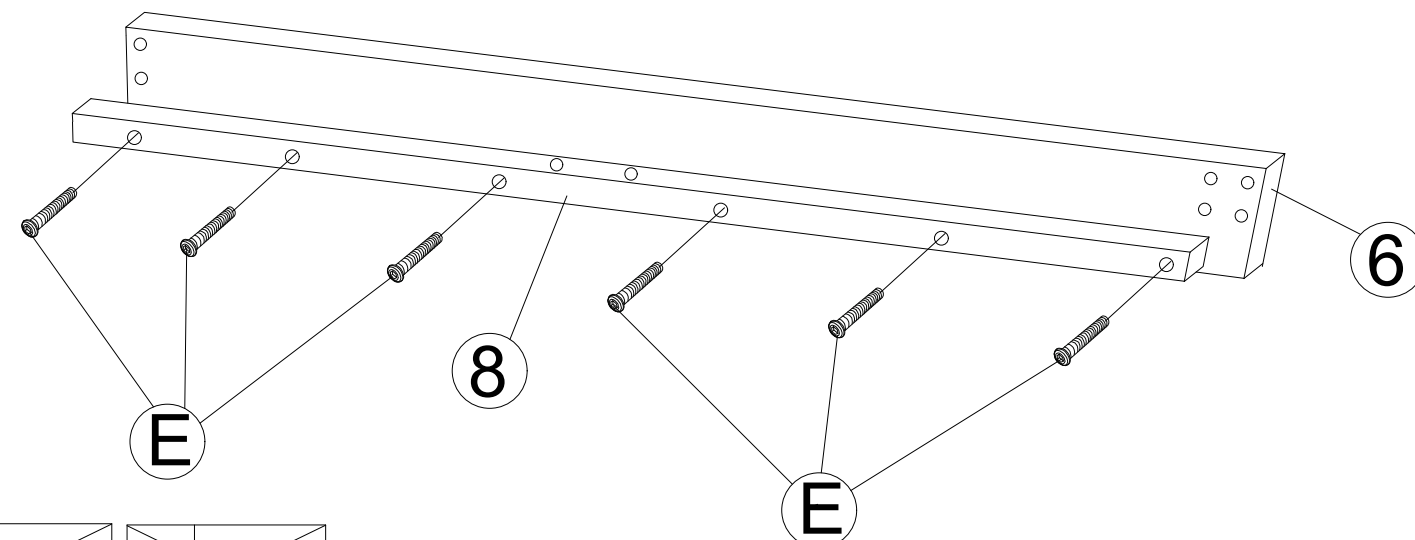

6



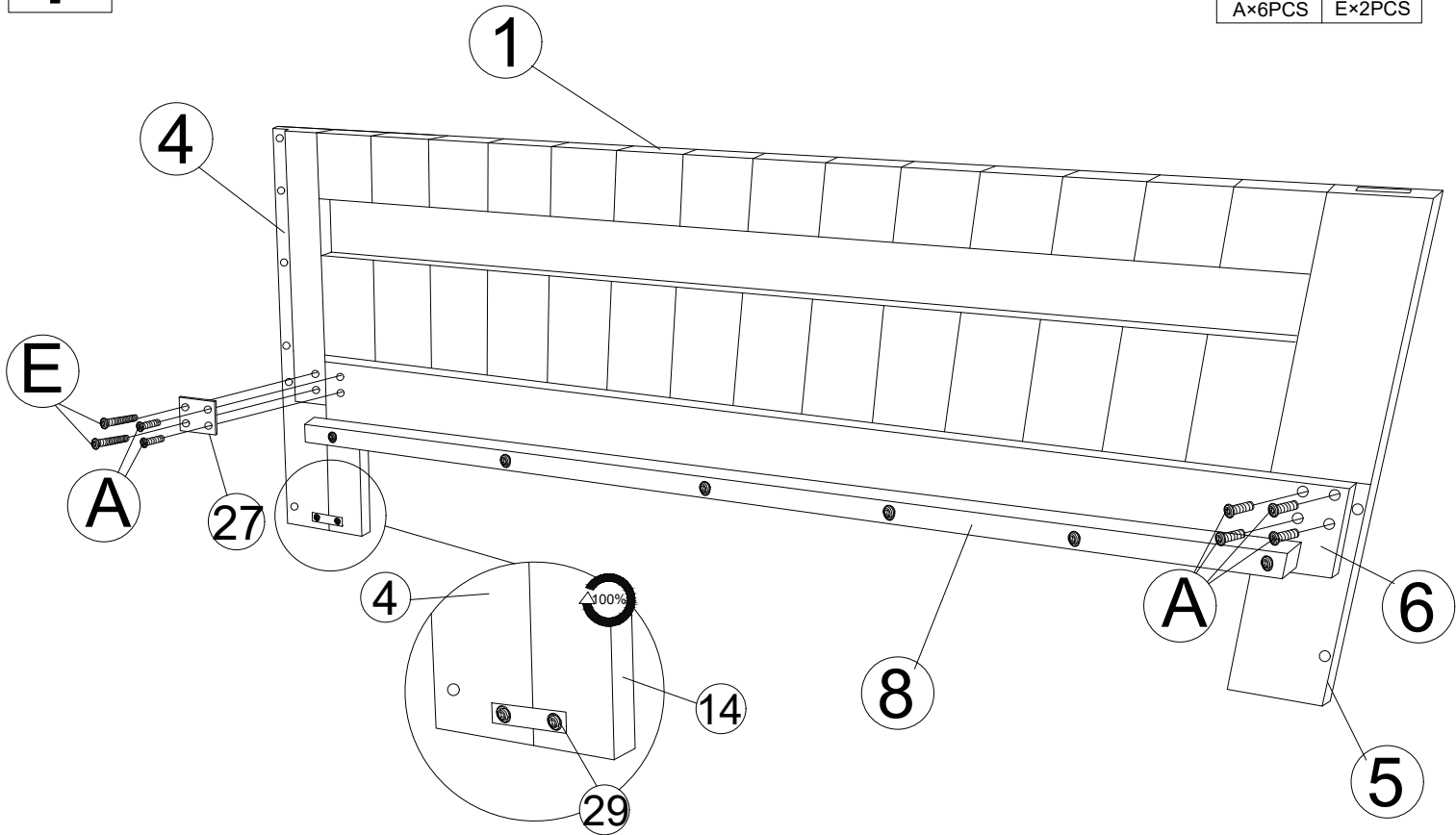

7

M8*40MM	M8*47MM
	
A×6PCS	E×2PCS



B	C	D	F
M8*55MM	M6*16MM	M8*20MM	M8*32MM

8

M8*40MM	M8*32MM
	
A×4PCS	F×2PCS

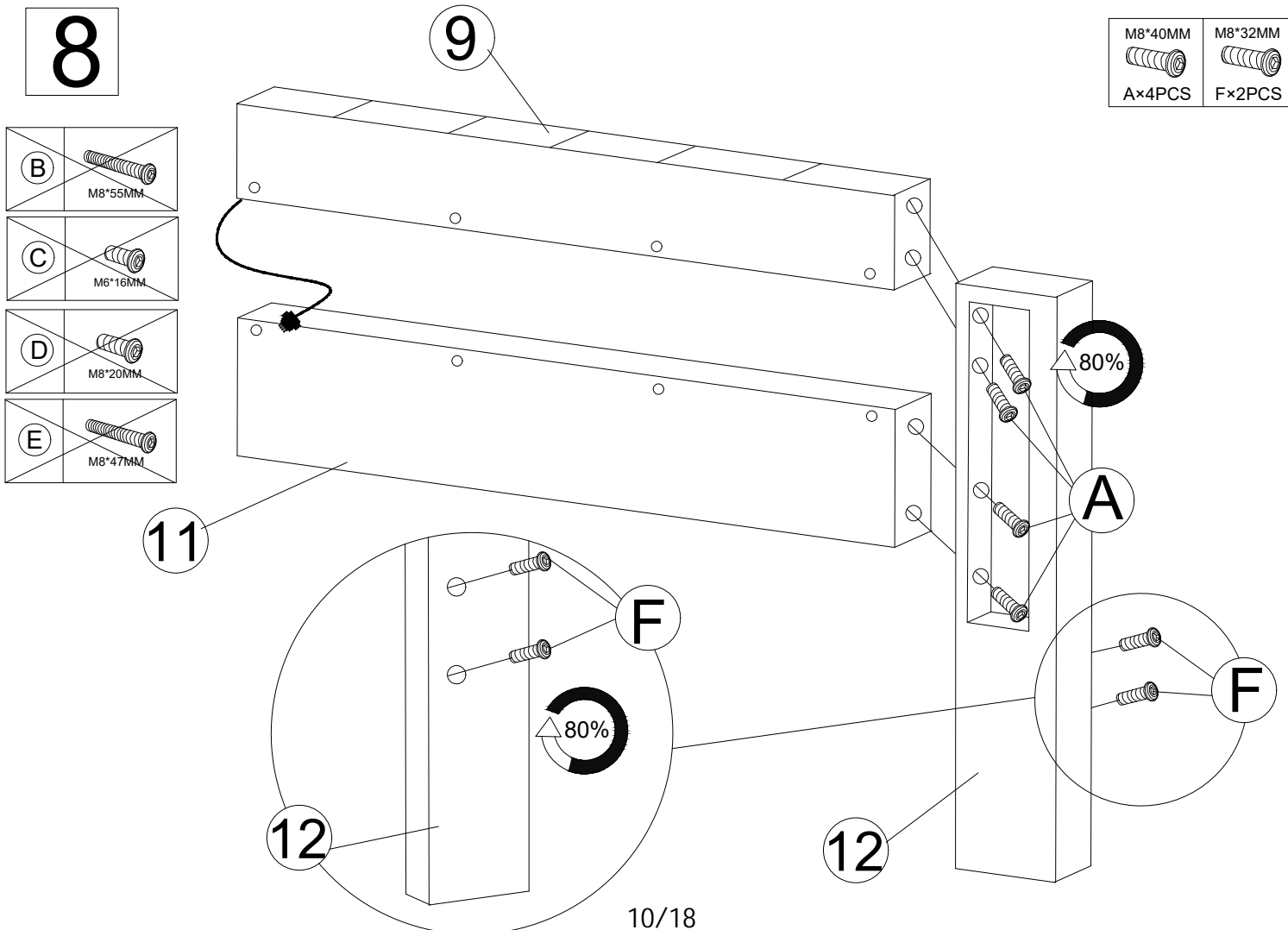

9

M6*16MM
C×8PCS

A	M8*40MM
B	M8*55MM
D	M8*20MM
E	M8*47MM
F	M8*32MM

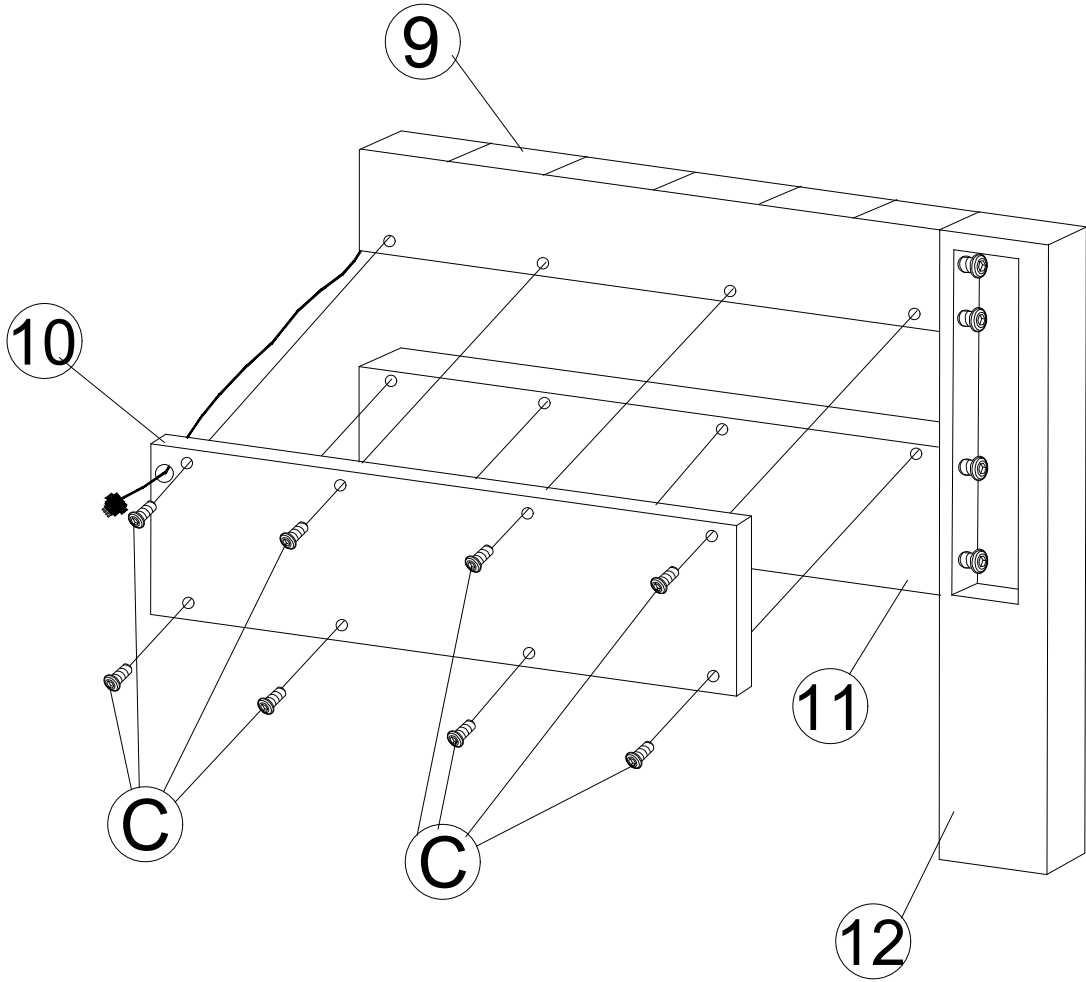

10

M8*32MM
F×2PCS

A	M8*40MM
B	M8*55MM
C	M6*16MM
D	M8*20MM
E	M8*47MM

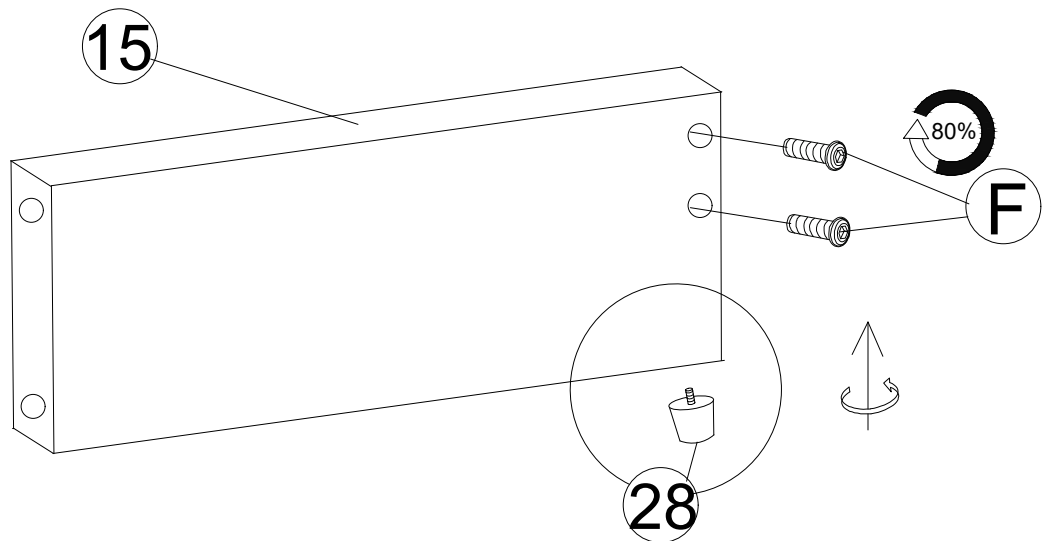

11

M8*55MM
Bx8PCS

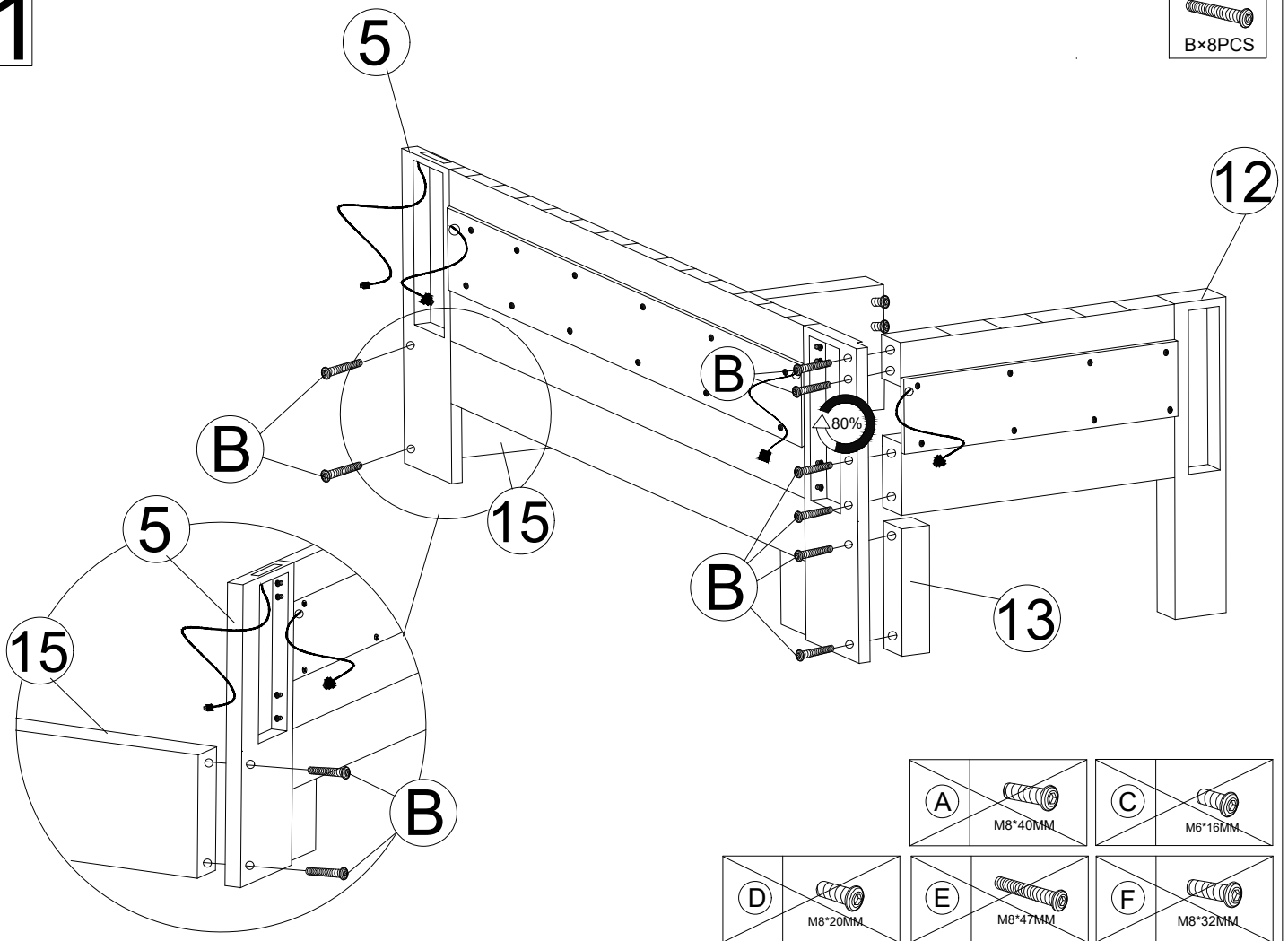

12

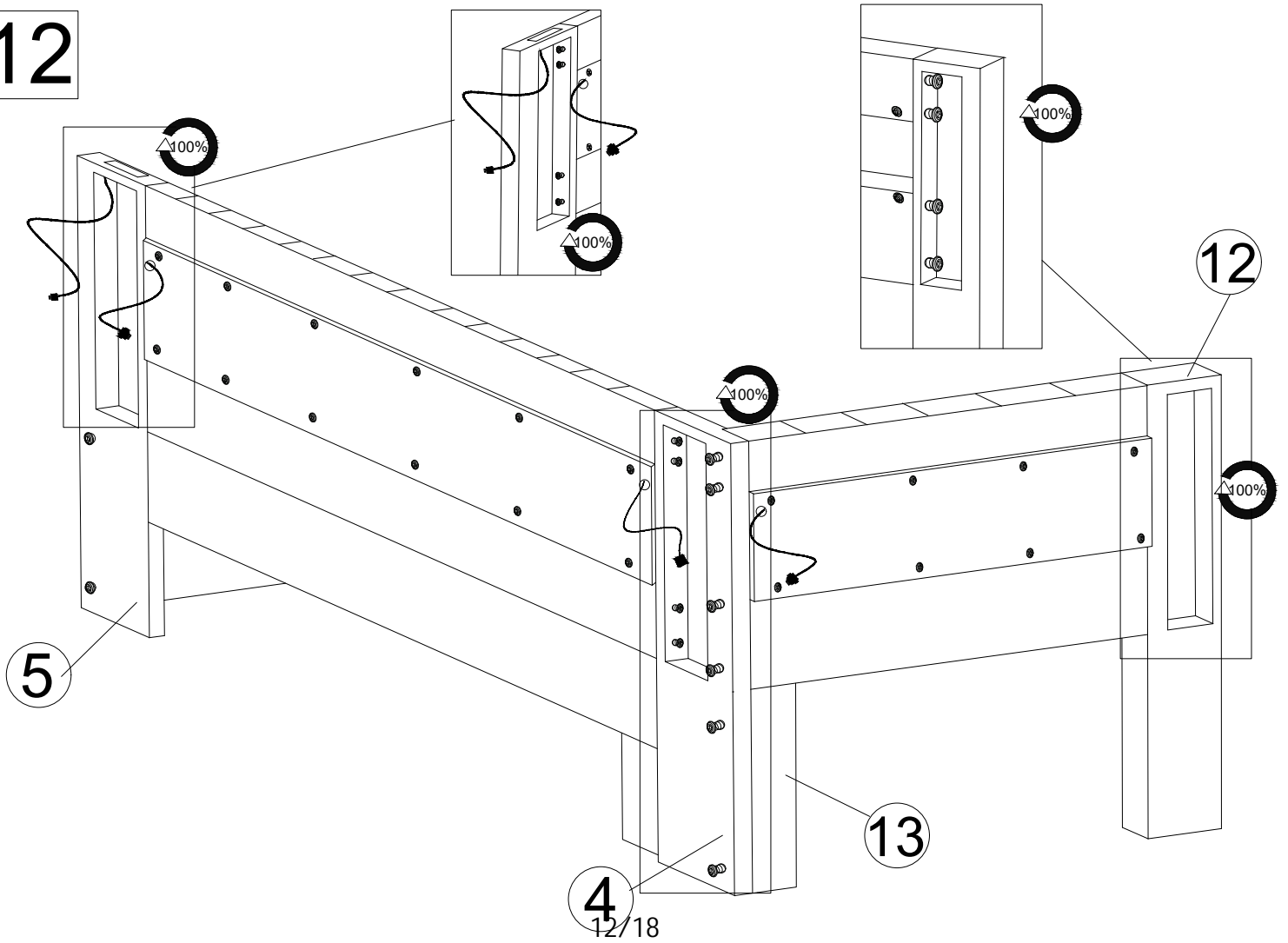

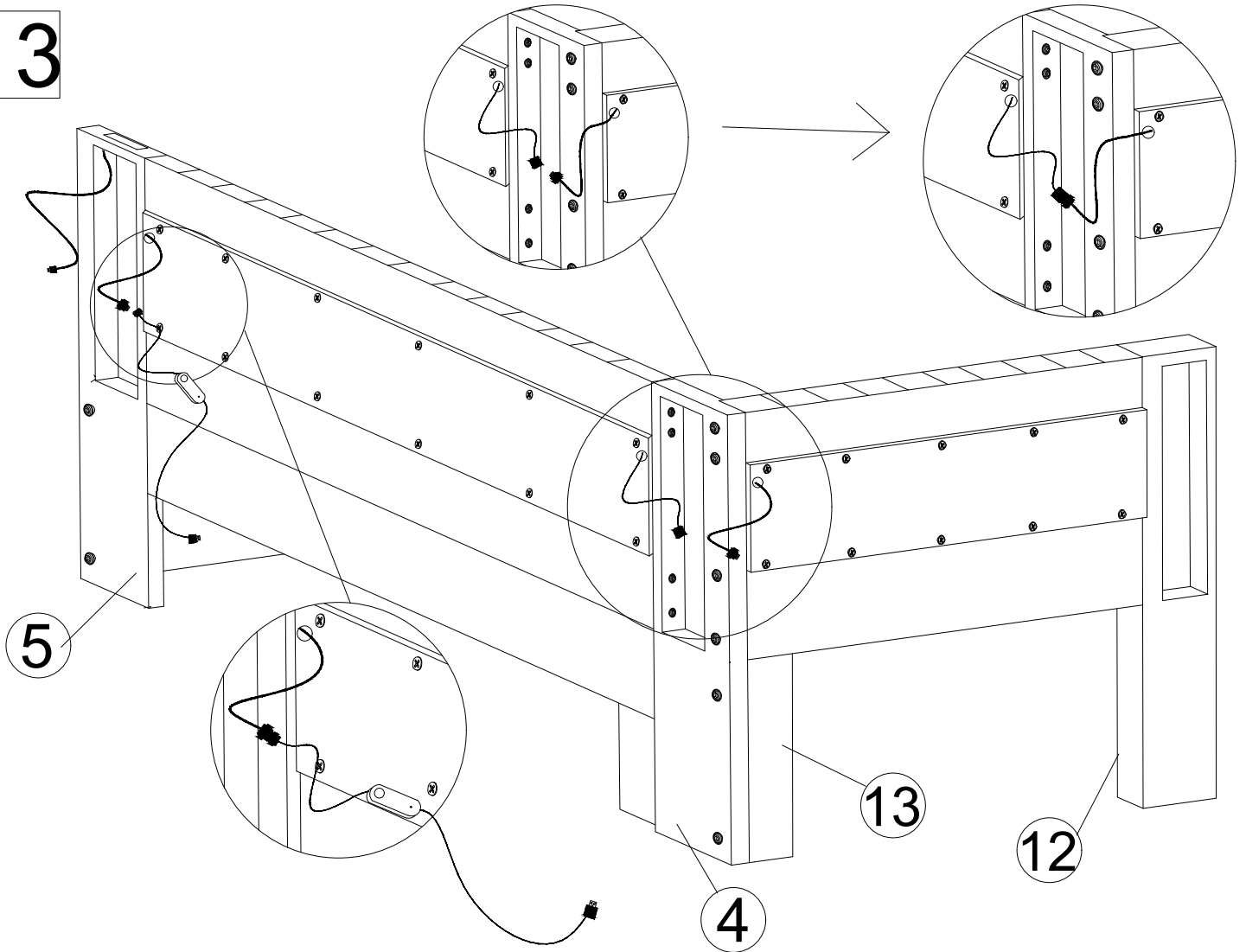

13



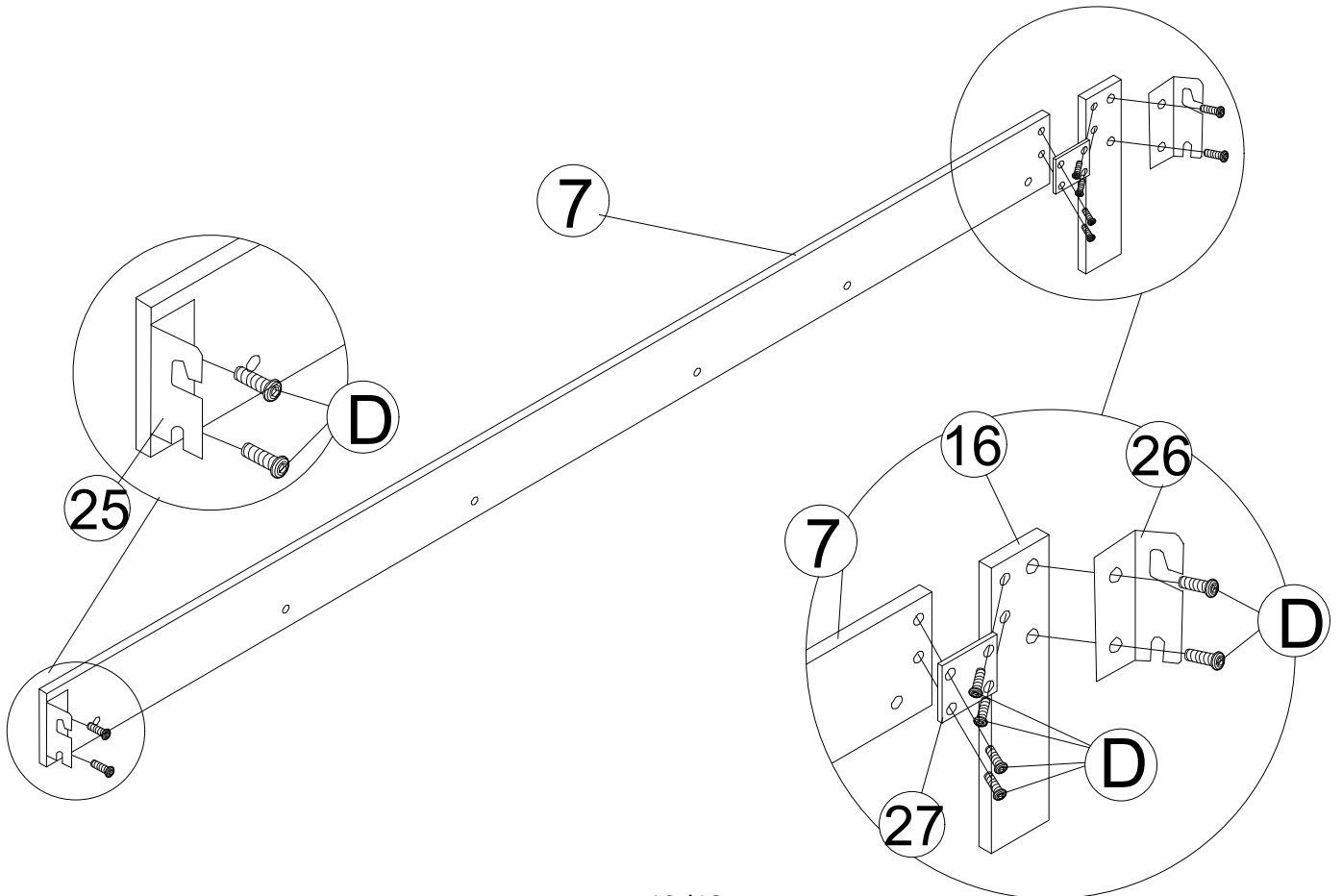
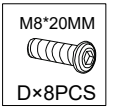
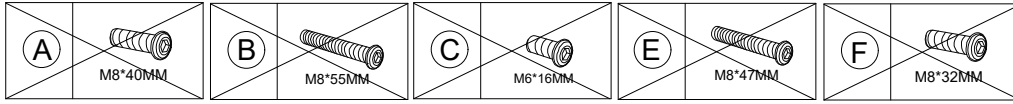



14

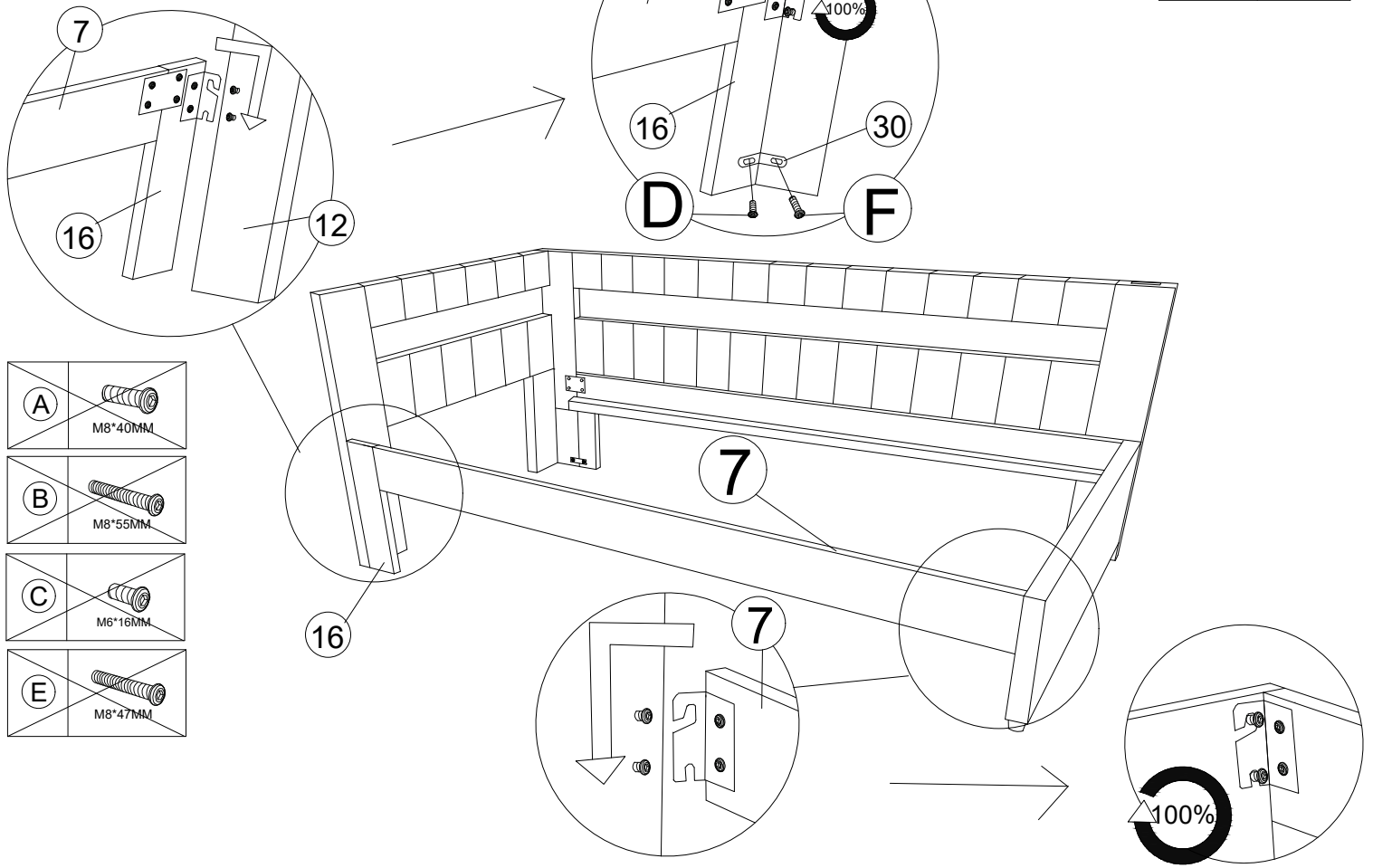

15

M8*20MM 	M8*32MM 
D×1PCS	F×1PCS





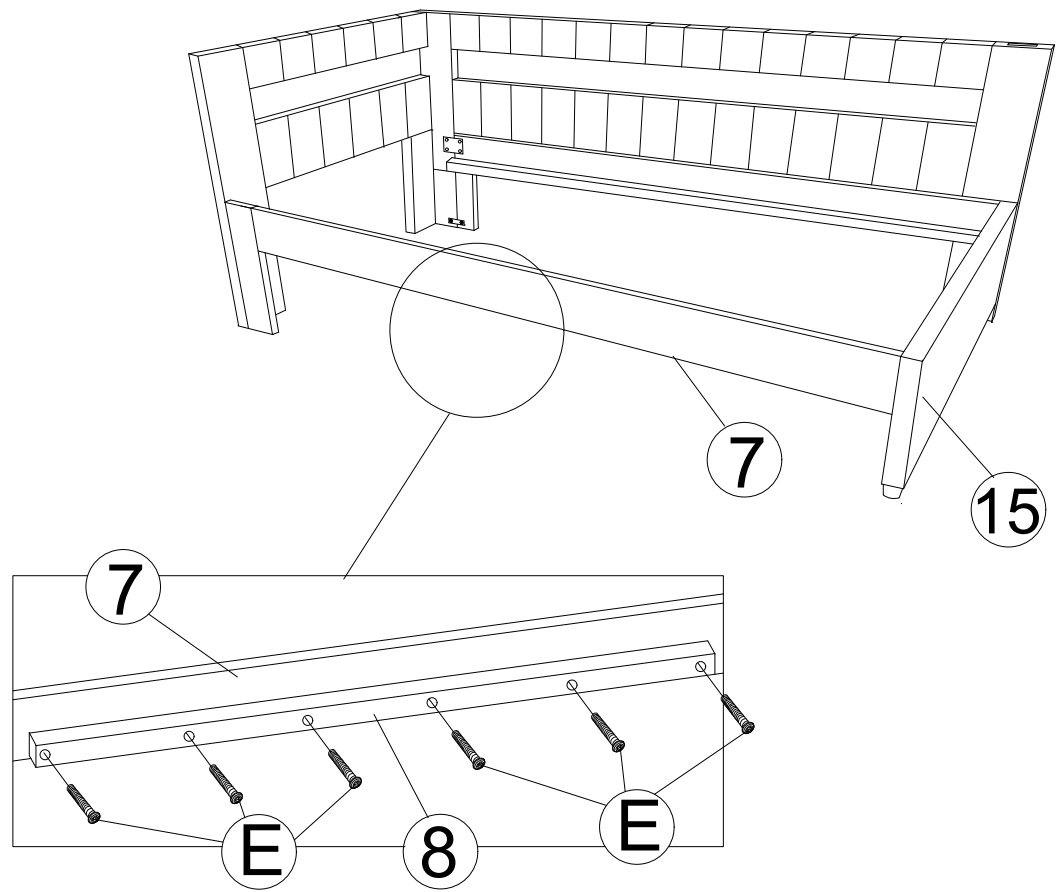

A		M8*40MM
B		M8*55MM
C		M6*16MM
E		M8*47MM

16

M8*47MM 
E×6PCS



A		M8*40MM
B		M8*55MM
C		M6*16MM
D		M8*20MM
F		M8*32MM

17

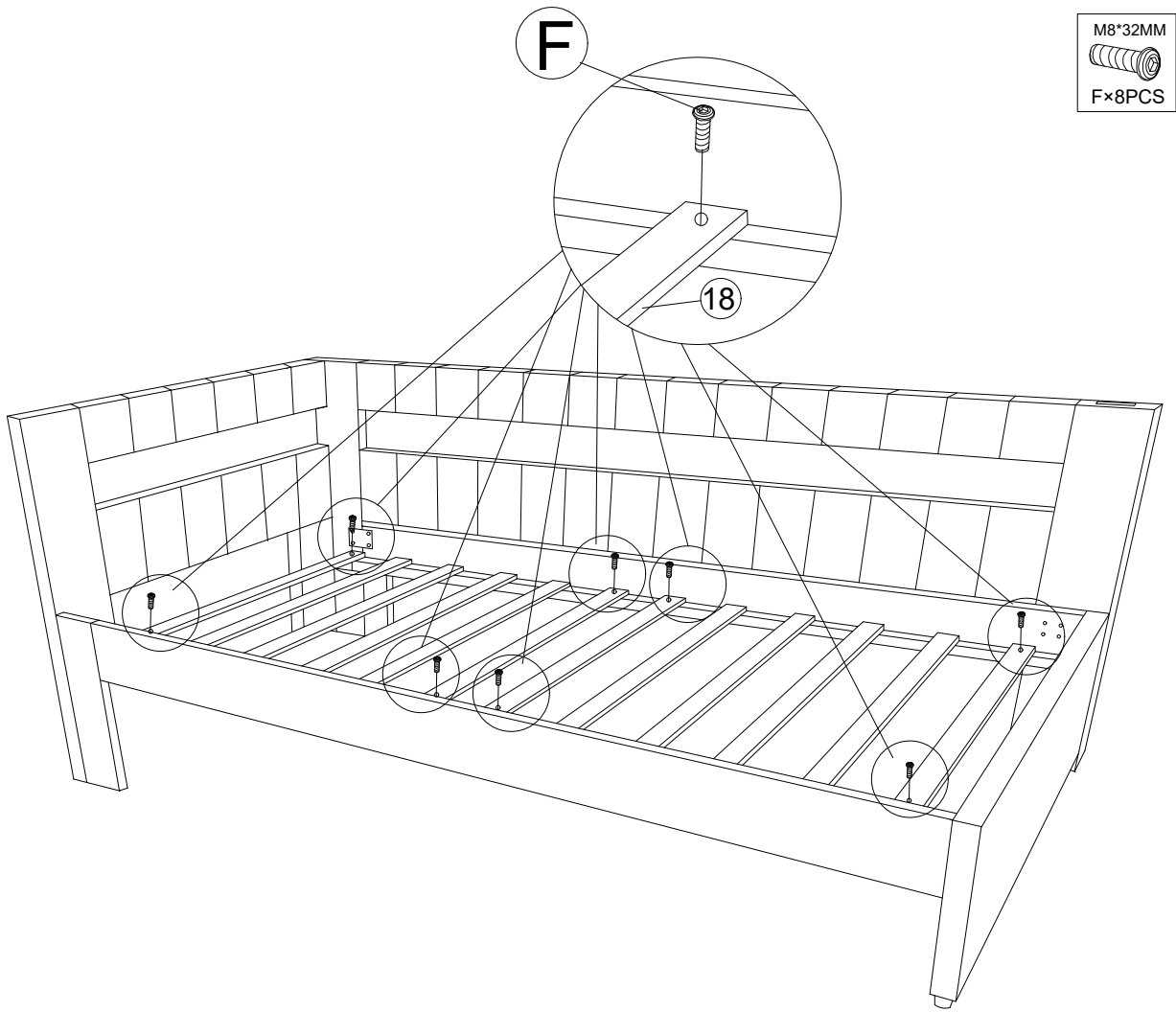
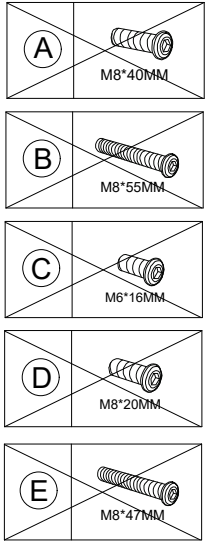

M8*32MM
F×8PCS

18

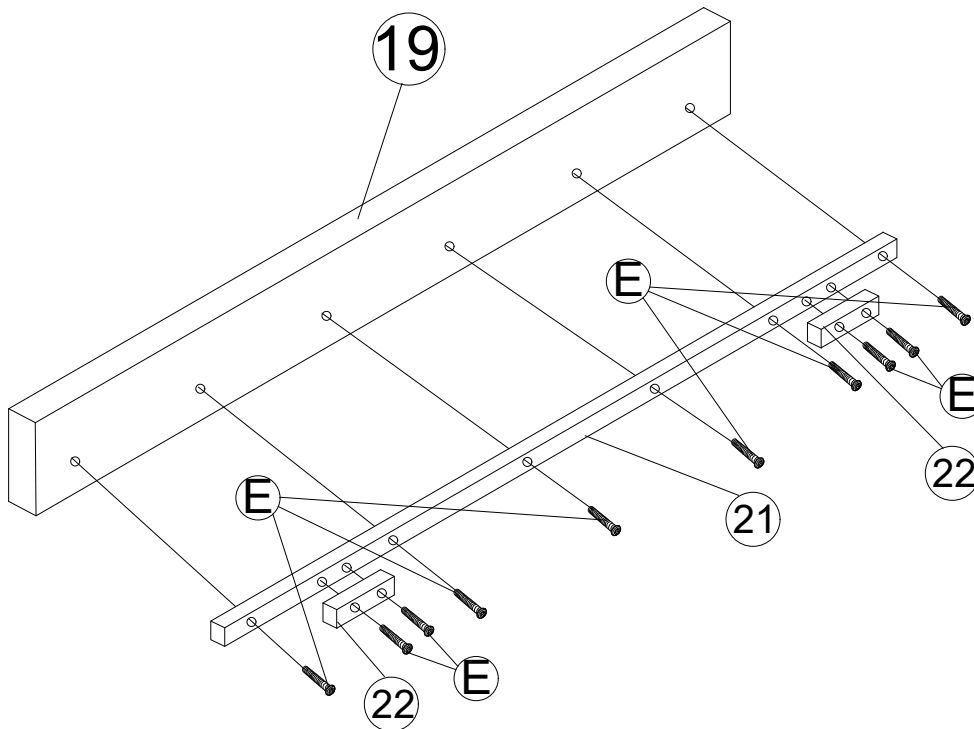

M8*47MM
E×10PCS

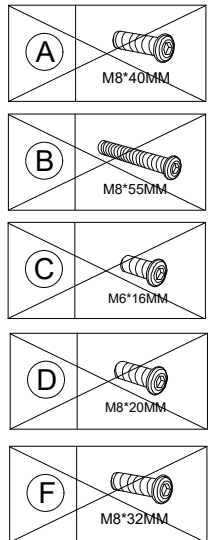

19

φ3*20
G×8PCS

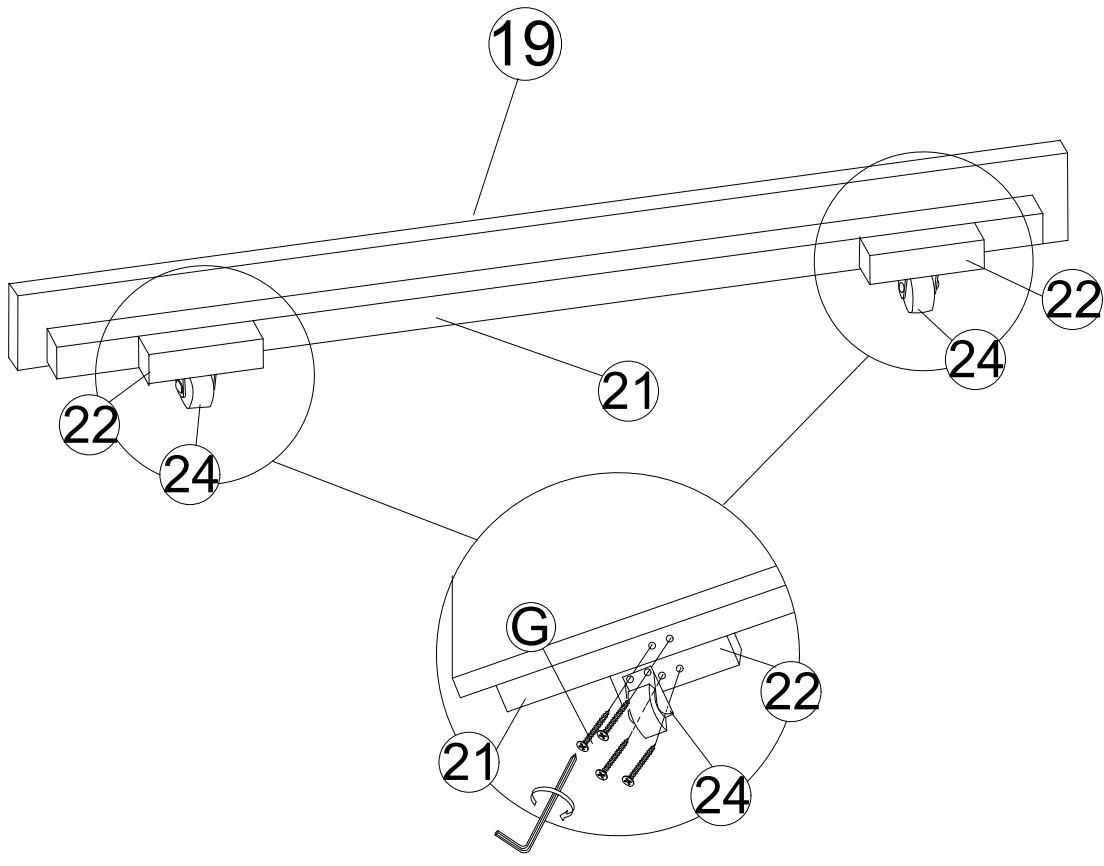

20

M8*47MM
E×10PCS

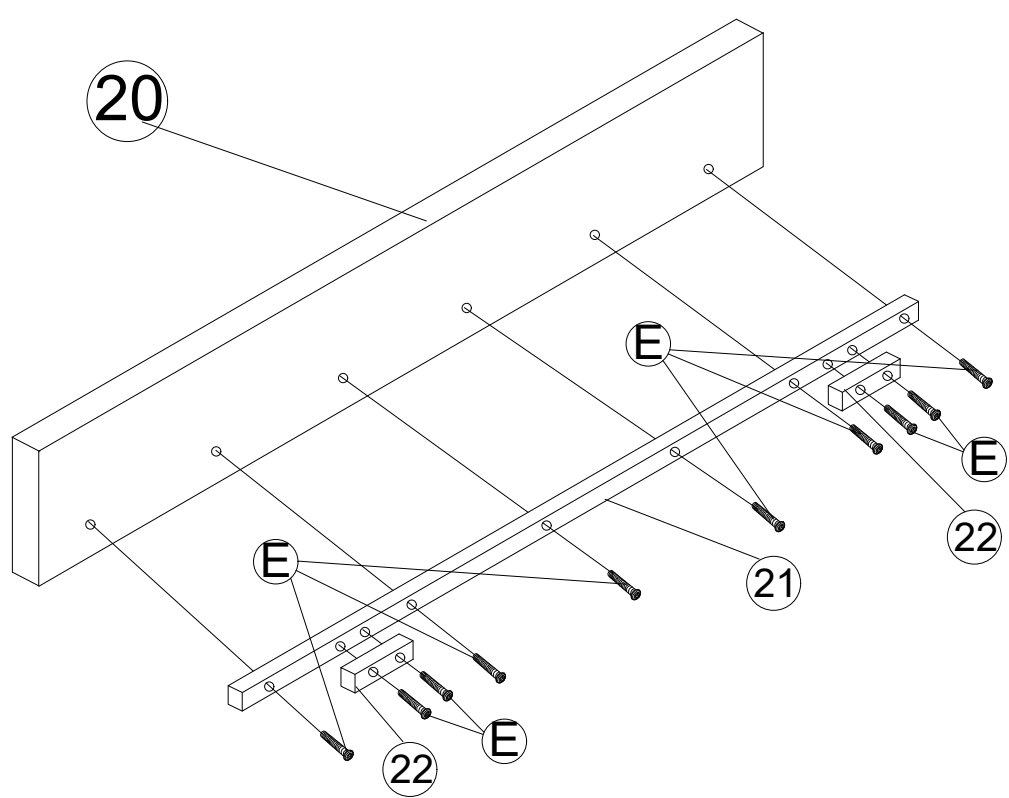

A	M8*40MM
B	M8*55MM
C	M6*16MM
D	M8*20MM
F	M8*32MM

21

φ3*20
G×8PCS

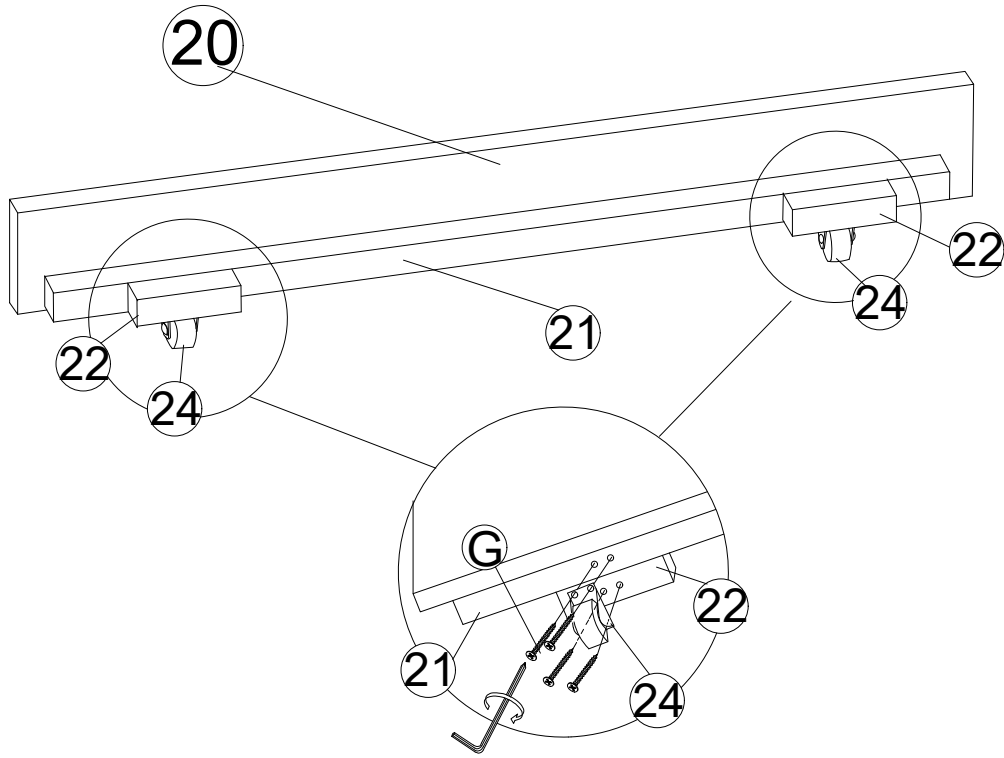

22

M8*32MM
F×8PCS

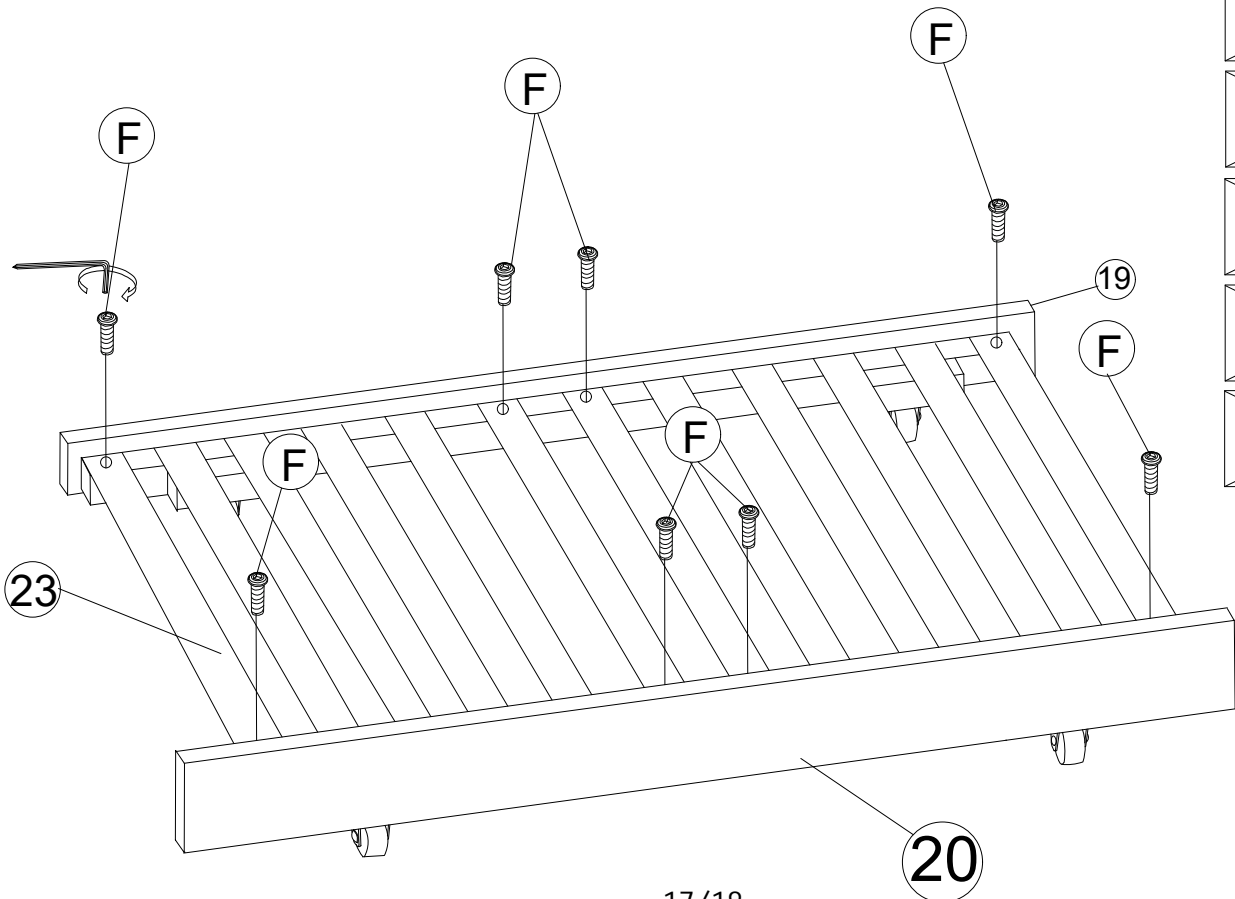

- | | |
|--------------|--------------------|
| A | M8*40MM |
| B | M8*55MM |
| C | M6*16MM |
| D | M8*20MM |
| E | M8*47MM |

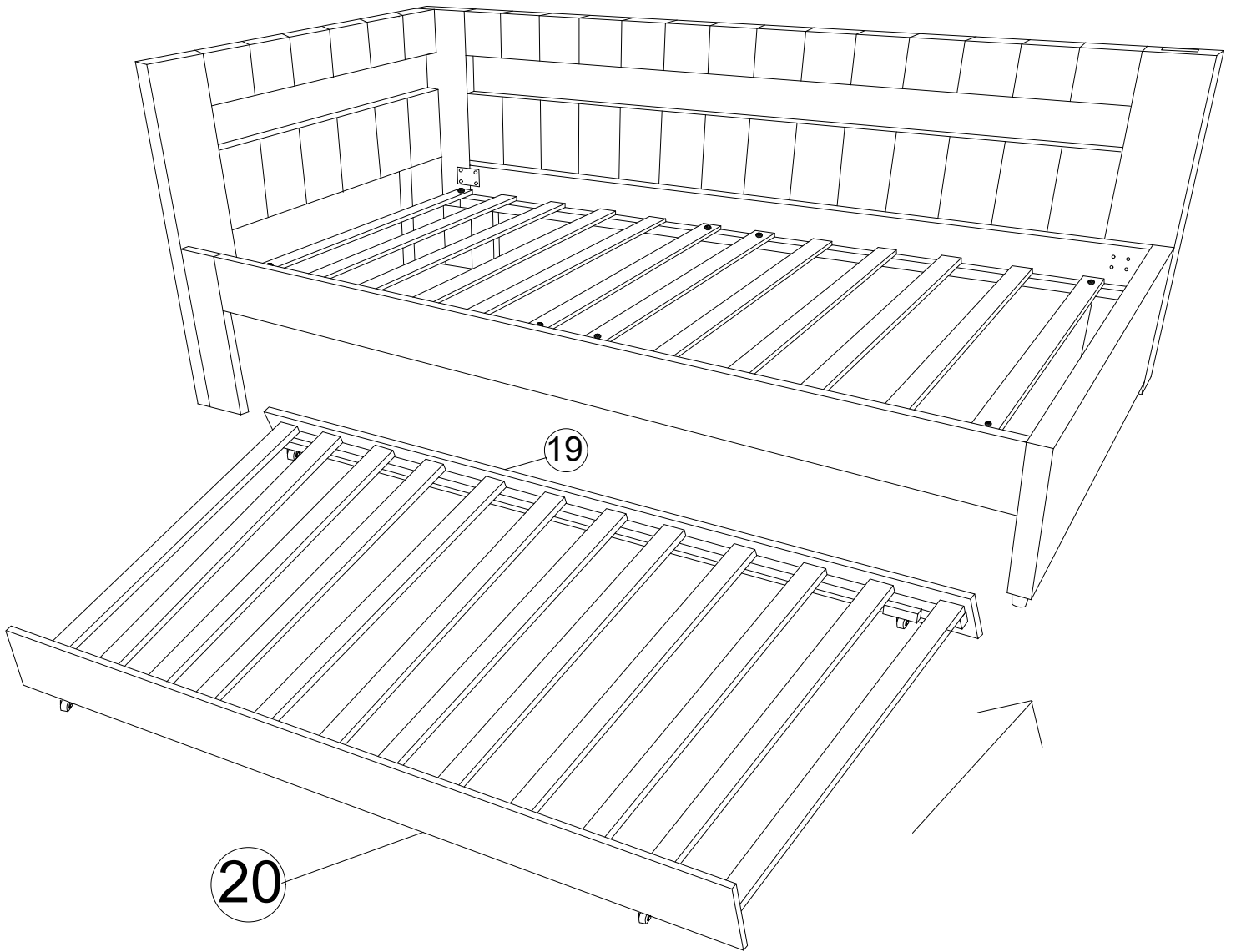

LotusLantern APP Manual

1. Software Overview

1.1 Overview

LotusLantern is a mobile APP to control LED strip by both Apple and Android phones.

The traditional control ways like infrared, 433MHz, 2.4GHz and others old wired ways will be replaced by mobile phone control way with convenient, powerful and scalable features.

Through this mobile APP, you can not only control the color, brightness and color temperature of the LED strips but also set up all kinds of fancy flash mode; Also this APP can change the light of the LED strip according to the rhythm of the music. This APP can set and control several LED strips through Bluetooth and the operation is very simple, easy to learn and easy to use.

1.2 Features

- Adjust color LED strips with 60,000 colors to change color and brightness and adjust monochrome LED strips to change brightness and color temperature
- Play music or turn on a sound playback device, you can let the light change the color and brightness with the rhythm of music, the music rhythm beautiful
- Inside multiple setting mode for color change and control LED strips without mobile
- Long distance control with omni-directional antenna, and many-to-many group control mode
- Once the connection is successful, connect automatically next time

1.3 Performance

LotusLantern APP is easy for use as well as great compatible for all kinds of smart phones; After the actual test of hundreds of mobile phones verification, the compatibility is above 95% of mobile phones in the market. APP is small and convenient, it consumes less system resources, so the requirements of the mobile configuration are low. Control delay is small, the operation feel good, light control is smooth with people's visual sense.

2. Operating Environment

This APP program requires phones of system above Android 4.3 and iOS 8.0. Mobile phone configuration is not limited.

3. Instructions

Note: Android version and iOS version download and use the same method, here in the Android version as an example.

3.1 APP Download

- Scan the QR code

iOS and Android systems can download the "LotusLantern" APP by scanning the QR code. Open the browser or other tools with "Scan QR code" function, scan the "LotusLantern" QR code as below:



3.2 App Operation

- (1) Click on the LotusLantern APP icon, enter the APP page:

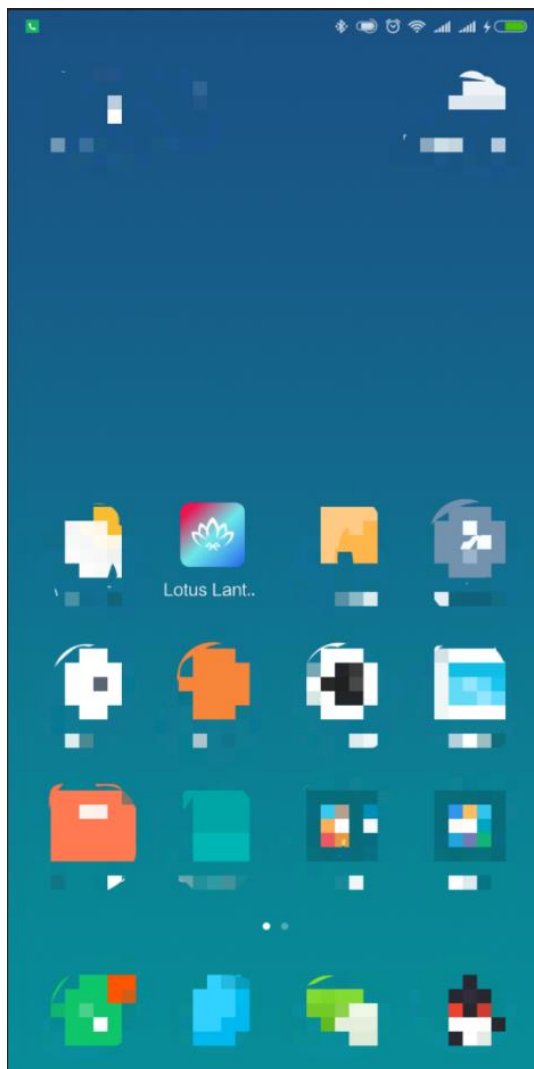

(2) After entering the APP interface, if Bluetooth is not enabled, "an application wants to enable the Bluetooth function of this device." Click [Allow]

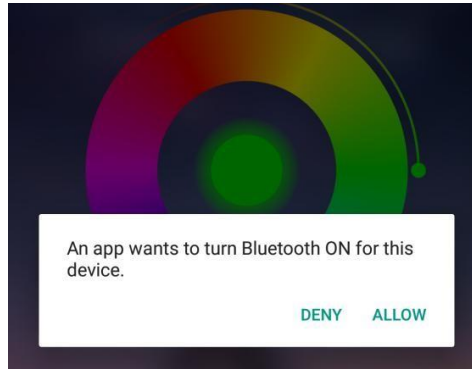

(3) switch to color and brightness interface:

A screenshot of a mobile application interface for color and brightness control. The interface is dark-themed. At the top, there is a navigation bar with a hamburger menu icon, a color wheel icon, and a gear icon. Below the navigation bar, there is a large color wheel for selecting colors. To the right of the color wheel is a toggle switch for the lamp. Below the color wheel, there is a section for RGB values: R 98, G 193, B 111. Below the RGB values is a brightness slider. At the bottom, there are two rows of color preset buttons: "Preset" and "Classic". At the very bottom, there is a navigation bar with icons for "Adjust", "Style", "Music", "Online", and "Mic".

Click to show the lamp list

Switch the color wheel

Click to display setting view

Lamp switch button

Adjust the color

Display the RGB value
Click to manual adjustment view

Click square icon to adjust the color

Click to shift the interface

(4) click to show the lamp list, view lamp list:

Bluetooth auto connect after search for devices

Lamp list

Status of device connection

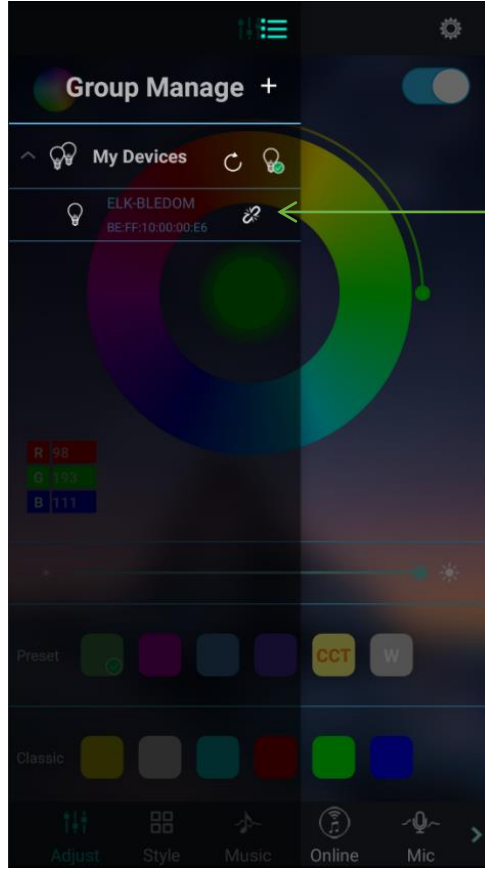
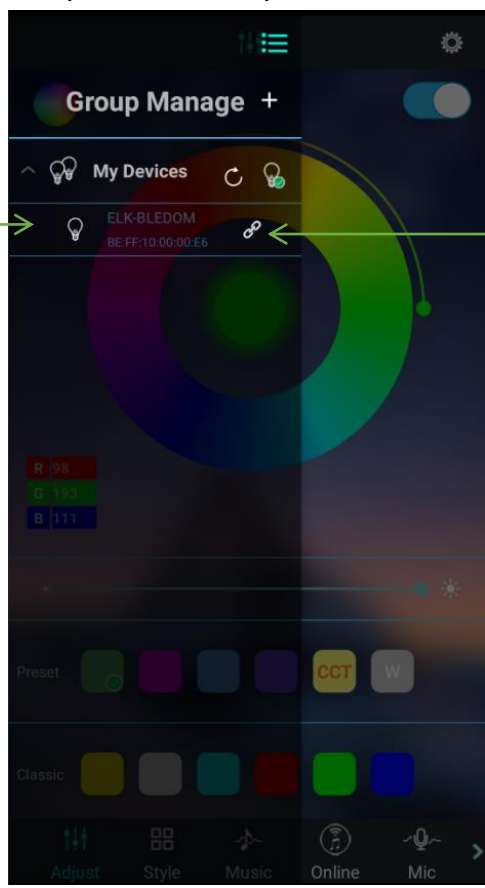

Status of device connection

(5) Click to RGB manual adjustment view:



(6) switch to the mode interface:

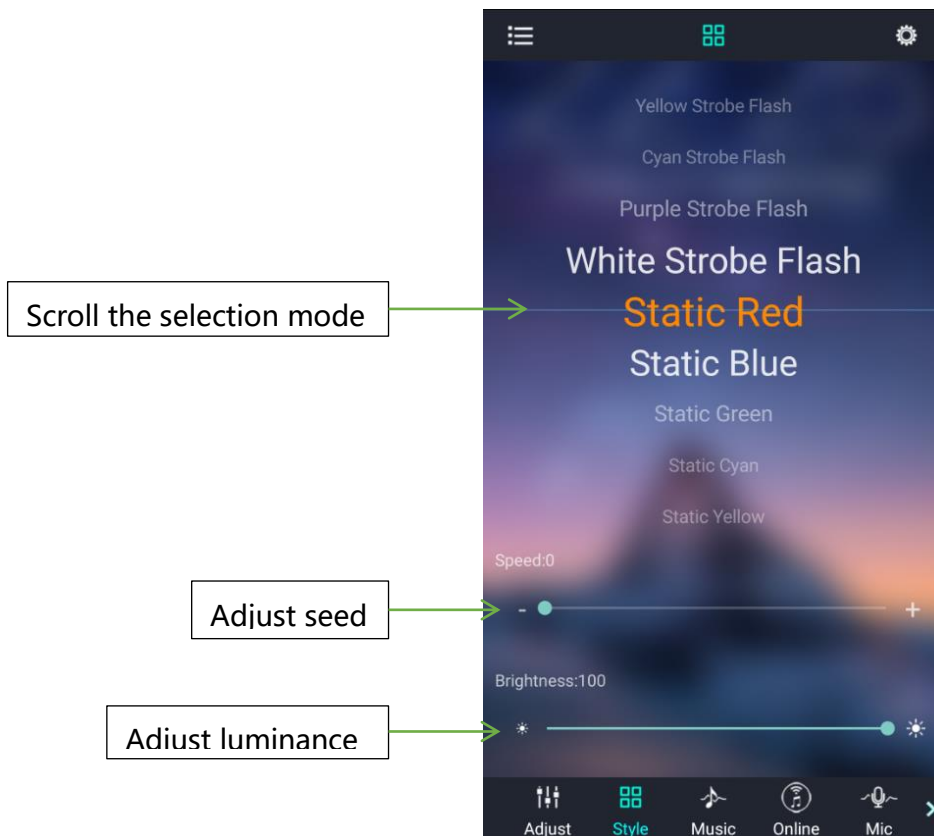

(7) switch to the music rhythm interface:

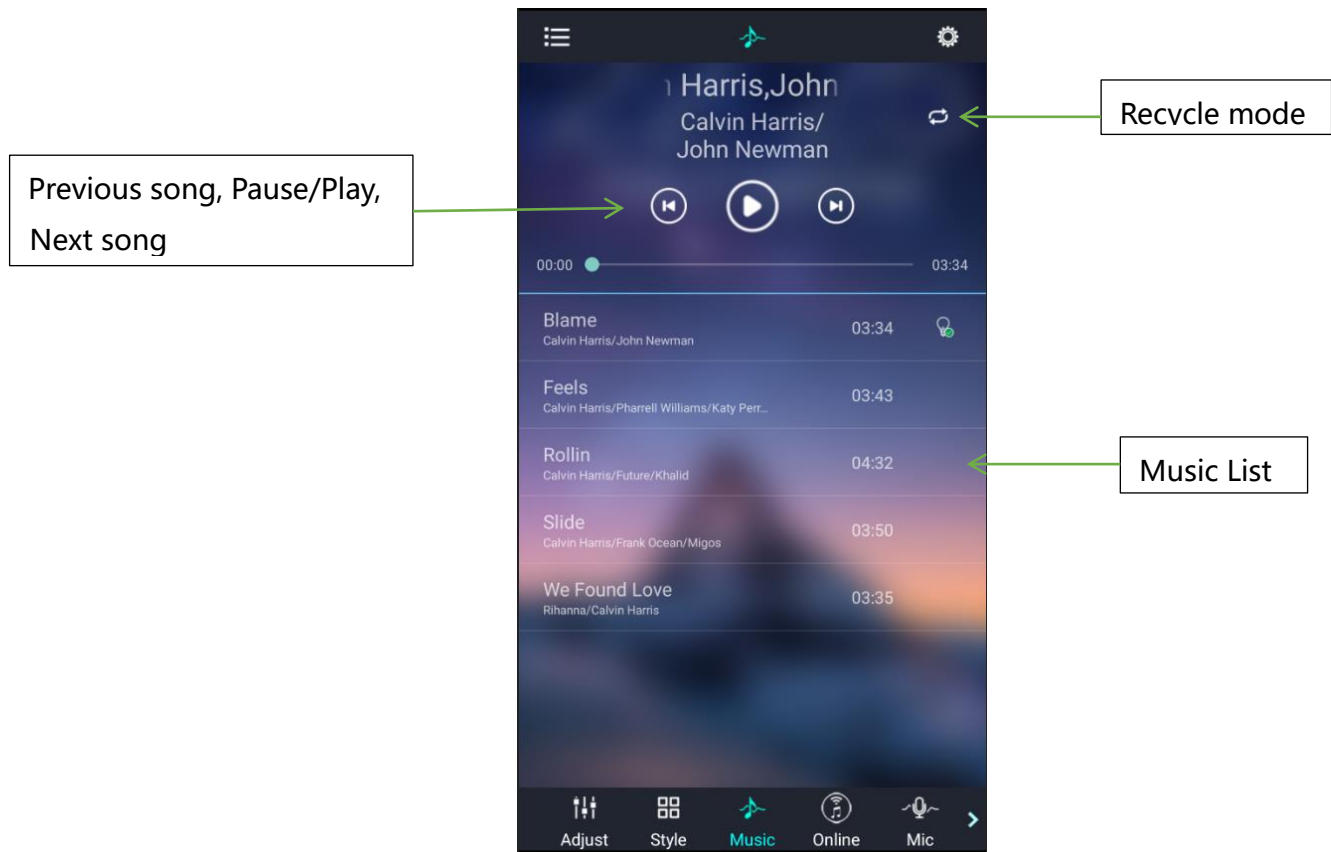

(8) Switch to the online music interface:

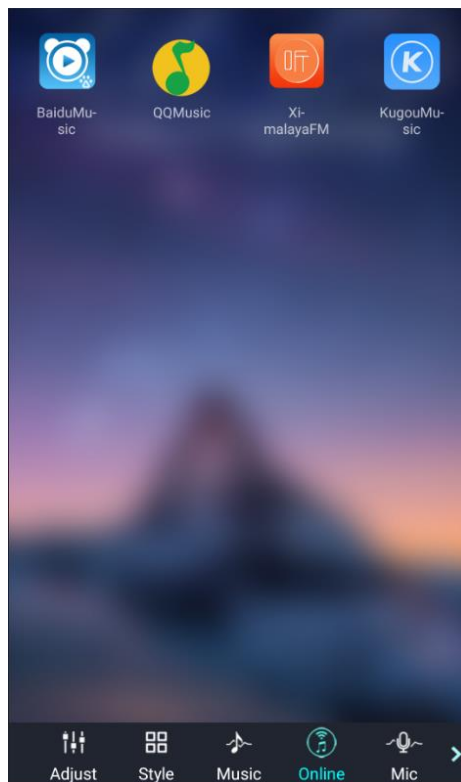

(9) Switch to the microphone rhythm interface:

Music rhythm through cell phone microphone

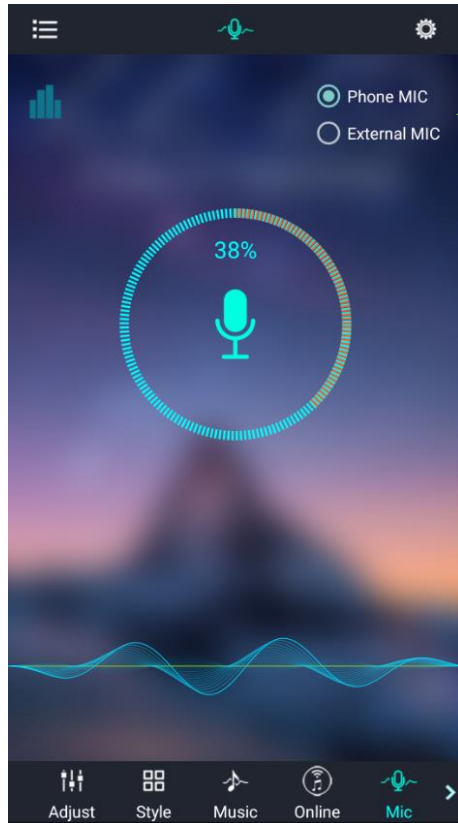

Switch phone microphone and external microphone

Music rhythm through the microphone on the product

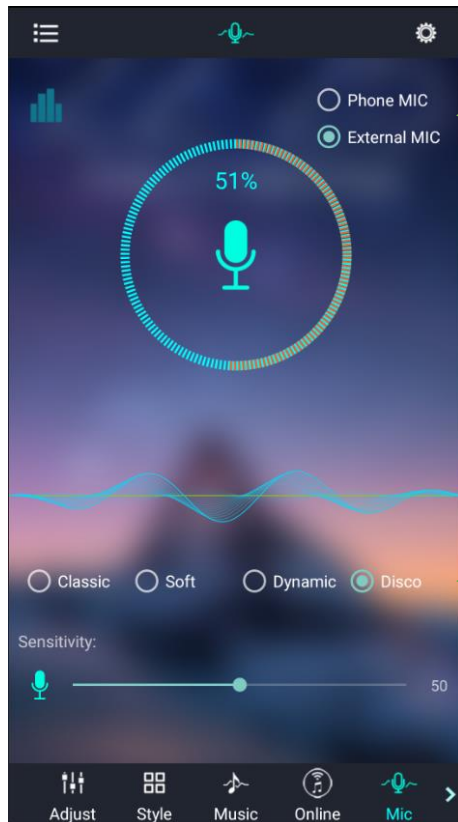

Switch phone microphone and external microphone

4-style rhythm

Change the sensitivity of MIC to match the sound

(10) Switch to the schedule interface:

The screenshot shows the 'Schedule' interface with two main sections: 'Schedule On' and 'Schedule Off'. Each section has a toggle switch, a 'Time' field set to '00:00', and a 'Repeat' row with seven circular buttons labeled 'MO', 'TU', 'WE', 'TH', 'FR', 'SA', and 'SU'. The 'Schedule On' toggle is currently turned off, and the 'Schedule Off' toggle is also turned off. The bottom navigation bar includes icons for 'Style', 'Music', 'Online', 'Mic', and 'Schedule'.

Annotations on the left side:

- Set the time of Light-On (points to the 'Time' field under 'Schedule On')
- Set the time of Light-Off (points to the 'Time' field under 'Schedule Off')

Annotations on the right side:

- Enable or disable the Light-On function (points to the 'Schedule On' toggle)
- Repeat setting
No selection for once Light-On (points to the 'Repeat' row under 'Schedule On')
- Enable or disable the Light-Off function (points to the 'Schedule Off' toggle)
- Repeat setting
No selection for once Light-Off (points to the 'Repeat' row under 'Schedule Off')

(11) Switch to the modify pin sequence interface:

The screenshot shows the 'Modify Pin Sequence' interface. At the top, there is a 'Modify Pin Sequence' title and a back arrow. Below the title is a 3D rendering of a pin header with a white connector. Below the pin header is a grid of 12 circular buttons arranged in three rows and four columns. The first row has buttons labeled 'V+', 'R', 'W', and 'W'. The second row has buttons labeled 'G', 'G', 'G', and 'G'. The third row has buttons labeled 'B', 'B', 'B', and 'B'. A red box highlights the first column of buttons (R, G, B). A green arrow points from the 'Click to save the new assignment' annotation to the 'R' button. Another green arrow points from the 'Change the real color of this line' annotation to the 'R' button.

Annotations on the left side:

- Click to save the new assignment (points to the 'R' button)
- Change the real color of this line (points to the 'R' button)

Verification of Compliance

Verification No.: MK25070091P01-E01

Name and address of Applicant: **Shenzhen CWG Technology Co., Ltd**
3/F, Building A, Yongshenghui Industrial Park, Chuangye Road, Shiyan Street, Bao'an District, Shenzhen

Name and address of Manufacturer: **Shenzhen CWG Technology Co., Ltd**
3/F, Building A, Yongshenghui Industrial Park, Chuangye Road, Shiyan Street, Bao'an District, Shenzhen

Product name: **LED Strip**

Rated: 5V ---

Product model(s): CWG-5050RGB-60D-5V, CWG-5050RGB-30D-12V, CWG-5050RGB-18D-12V, CWG-5050RGB-60D-24V, CWG-5050RGB-60D-12V, CWG-5050RGB-30D-5V, CWG-5050RGB-18D-5V, CWG-5050-60D-12V, CWG-5050-30D-12V, CWG-5050-60D-24V, CWG-HC5050RGB-60D-12V, CWG-HC5050RGB-30D-12V, CWG-HC5050RGB-60D-24V, CWG-HC5050-60D-12V, CWG-HC5050-30D-12V, CWG-HC5050-60D-24V, CWG-HC5050RGB-30D-5V, CWG-HC5050RGB-60D-5V, CWG-HC5050RGB-144D-5V, CWG-2835-60D-12V, CWG-2835-120D-12V, CWG-2835-60D-24V, CWG-2835-120D-24V, CWG-2835-60D-5V, CWG-2835-120D-5V

Product trademark: 创唯光

This verification confirms that the product meets the requirements of the following standard. The conformity was demonstrated based on following standard(s) listed by European Commission as harmonized with EMC Directive 2014/30/EU.

EN IEC 55015:2019+A11:2020
EN IEC 61547:2023

The verification has been carried out in accordance with individual rules and conditions agreed with the applicant. Evaluation has been carried out in accordance with:

Test report(s) No.: MK25070091P01-E01
Test conducted by: TMC Testing Services (Shenzhen) Co., Ltd.
Verification issue date: July 17, 2025

Notes:

This verification refers to the above mentioned product and its conformity in regards of above mentioned standard(s) was proven on test sample.

This verification does not imply meeting all essential requirements, assessment of the series-production or any other restricted Notified Bodies conformity assessment procedure appropriate for the product.

This verification holder shall use this verification in connection to verification of conformity and technical data relevant for the product the verification was issued.

TMC Testing Services (Shenzhen) Co., Ltd.

t:86-755-86642861 cert@tmc-lab.com www.tmc-lab.com
1st Floor, Block A1, Zone A, Xinshidai Gongrong Industrial Park, No. 2, Shihuan Road, Shiyan Street, Baoan District, Shenzhen, China





Product Service

Attestation of Conformity

No. E8A 128892 0006 Rev. 00

Holder of Attestation: **GUANG TAI ENTERPRISE CO., LTD.**Rm 402, Bldg 4. No.2 Dapianmei Rd.
Dapianmei Village, Dalingshan
523000 Dongguan, Guangdong
PEOPLE'S REPUBLIC OF CHINA**Name of Object:** **Power supply
(Furniture Power Distribution Unit)****Model(s):** **JN00-00-02K, JN00-00-03K, JN00-00-04K, JN02-00-21,
JN02-00-22, JN02-00-23, JN02-00-23K, JN02-00-24K,
JN02-00-24, JN02-00-22M, JN02-00-23M, JN02-00-23KM****Description of Object:** Ratings:
Input: 220-250VAC, 50Hz, Max 16A, Max 3680W
USB A1/USB A2 Output: 5.0VDC, 2.1A, 10.5W Max
Total USB output: 5.0VDC, 2.1A, 10.5W Max
Protection Class: I**Tested according to:** EN 55032:2015/A1:2020
EN 55035:2017/A11:2020
EN IEC 61000-3-2:2019/A1:2021
EN 61000-3-3:2013/A2:2021

This Attestation of Conformity is issued on a voluntary basis according to the Directive 2014/30/EU relating to electromagnetic compatibility. It confirms that the listed apparatus complies with the principal protection requirements of the directive and is based on the technical specifications applicable at the time of issuance. It refers only to the particular sample submitted for conformity assessment. For details see: www.tuvsud.com/ps-cert

Test report no.: 657602423101**Date,** 2025-01-10

(Laurent Yuan)

Page 1 of 1

This Attestation does not replace the regulatory EU Declaration of Conformity (DoC) and does not allow for CE marking. After preparation of the necessary documentation and establishing compliance to requirements of all applicable directives, the manufacturer may sign a DoC and apply the CE marking. The DoC is issued under the sole responsibility of the manufacturer.