

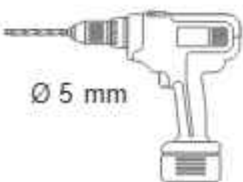

Modell **LUNA**

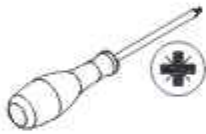

Ø 5 mm

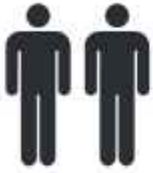
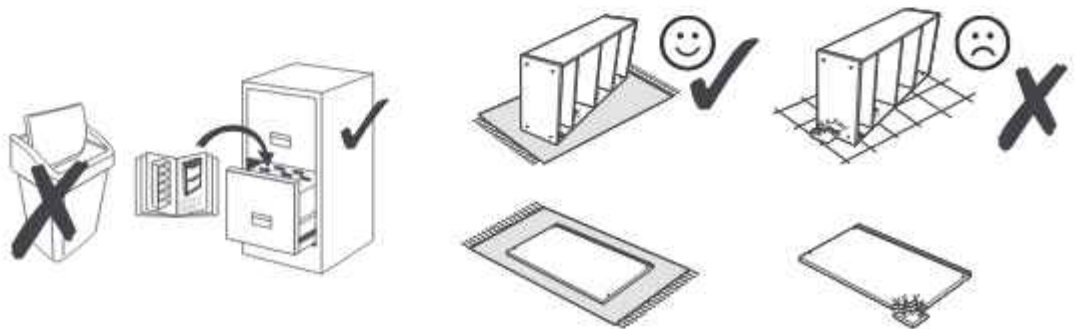
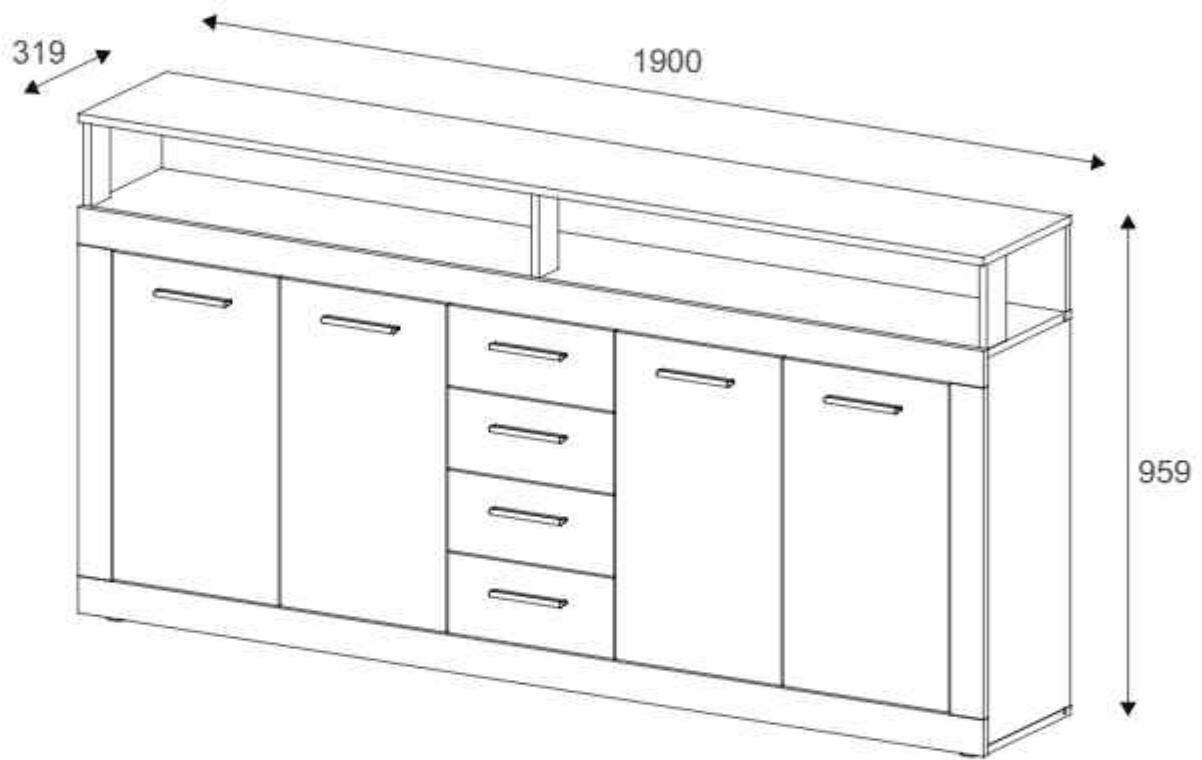

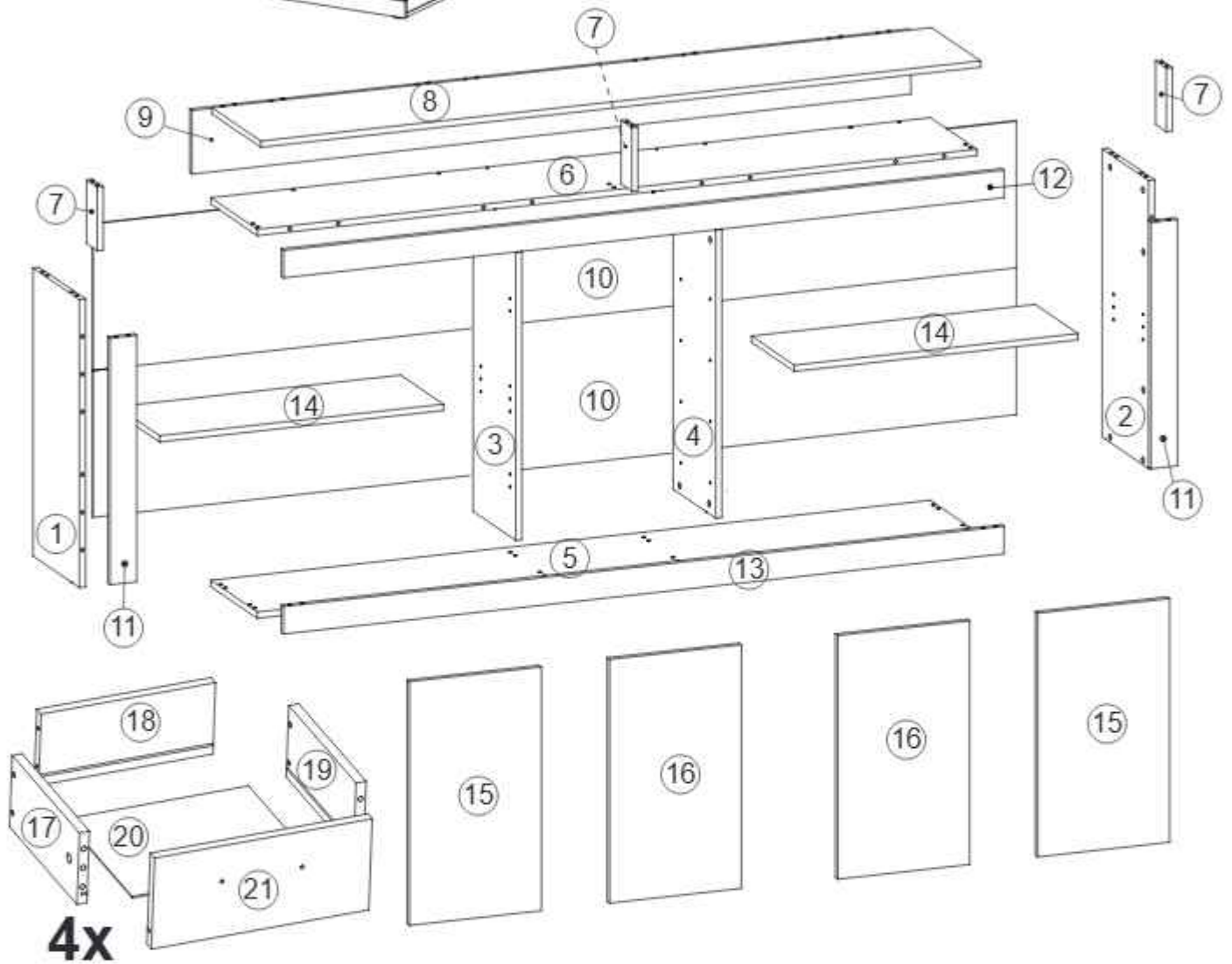





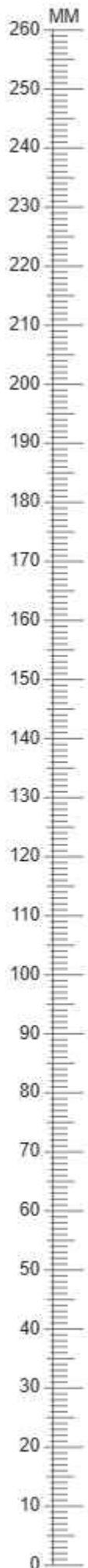
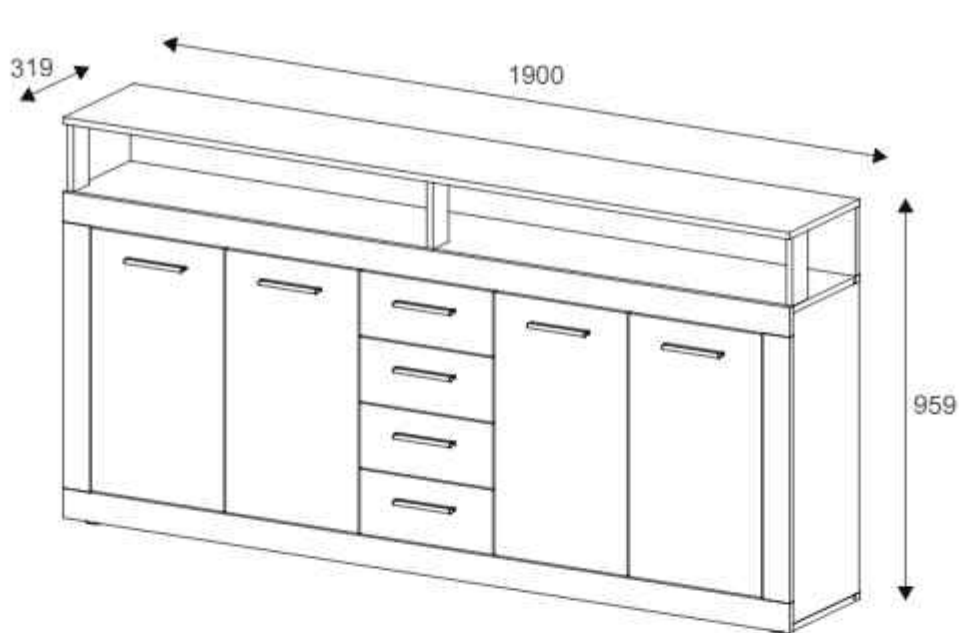

A	B (mm)		C
1	734	303	1/3
2	734	303	1/3
3	734	303	1/3
4	734	303	1/3
5	1900	303	2/3
6	1900	303	2/3
7	162	70	1/3
8	1900	319	2/3
9	1898	162	2/3
10	1896	382	2/3
11	748	352	1/3
12	1902	70	2/3

A	B (mm)		C
13	1902	70	2/3
14	749	303	1/3
15	621	348	3/3
16	621	348	3/3
17	300	120	1/3
18	279	120	1/3
19	300	120	1/3
20	294	299	1/3
21	348	153	3/3



1x 4mm  z1	19x  Ø 6,3x50mm e27	16x  Ø 12mm s4	38x  Ø 20mm s2
45x Ø 8x30mm  f1	8x Ø 8x50mm  f2	56x Ø 15x12mm  r1	56x 45mm  r23
4x L=300mm R L  n1/1	4x L=300mm R L  n1/2	8x Ø 5mm  d1	6x 15x45xmm  k44
4x Ø 35mm  ab3	4x Ø 35mm  ab2	6x Ø 4x20mm  p27	1x Ø 4,2x13mm  p27
8x L=128/148mm  c237	1x 154x16x1mm  n26/1	80x Ø 2x20mm  g1	16x Ø 4,2x32mm  p63
8x Ø 5mm  s7	16x Ø 6,3x13mm  e4	16x Ø 3x16mm  p50	16x Ø 3,5x16mm  p51

1

f1 x 24



∅ 8x30mm

d1 x 8



∅ 5mm

b2 x 4



40x50x12mm

e4 x 16



∅ 6,3x13mm

r1 x 20



∅ 15x13mm

n1/1 x 4



l=300mm

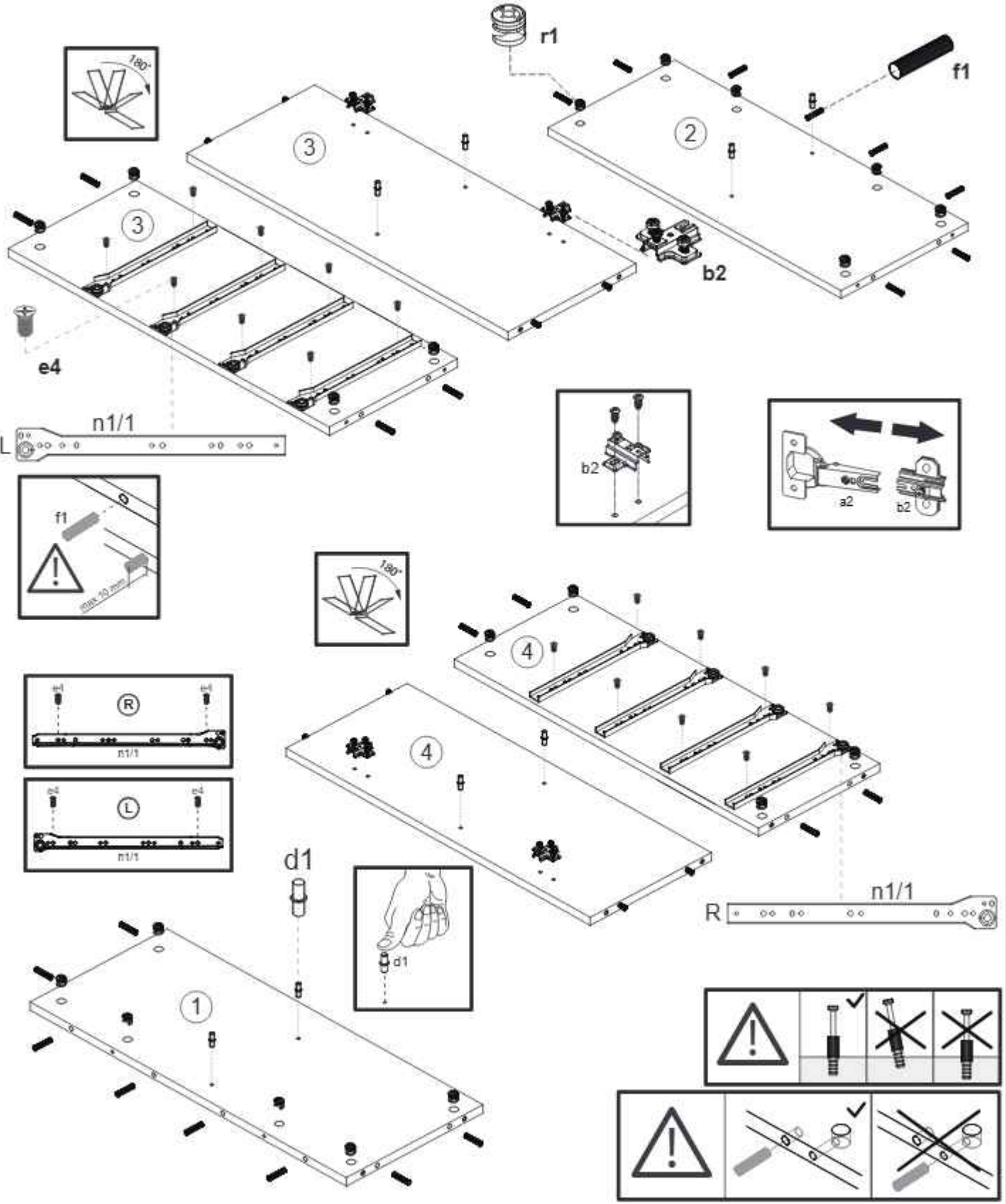

2

f1 x 21



Ø 8x30mm

r1 x 12



Ø 15x13mm

r23 x 16



45mm

f2 x 8



Ø 8x50mm

b3 x 4



40x50x12mm

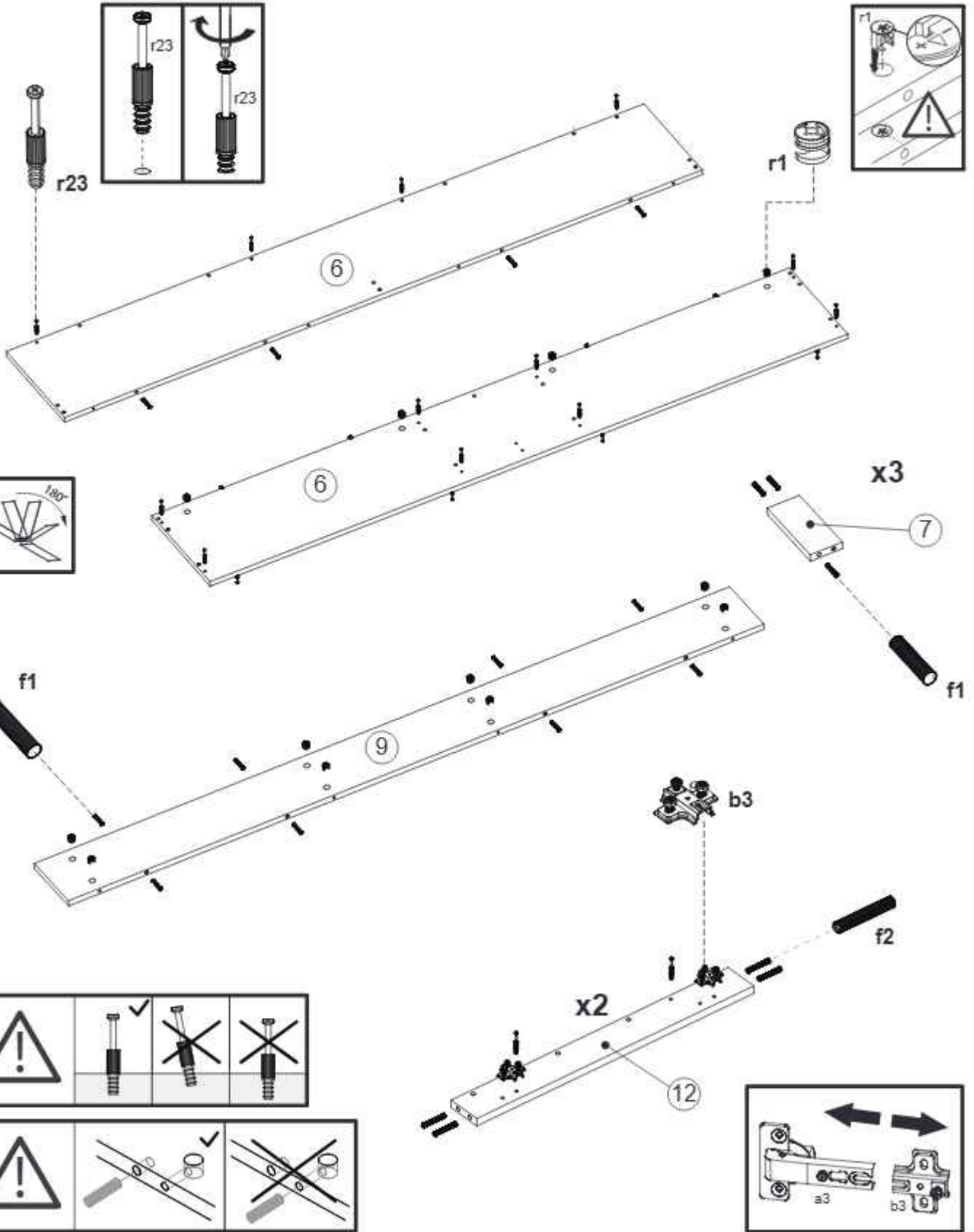

3

f1 x 4



Ø 8x30mm

r1 x 4



Ø 15x13mm

r23 x 20



45mm

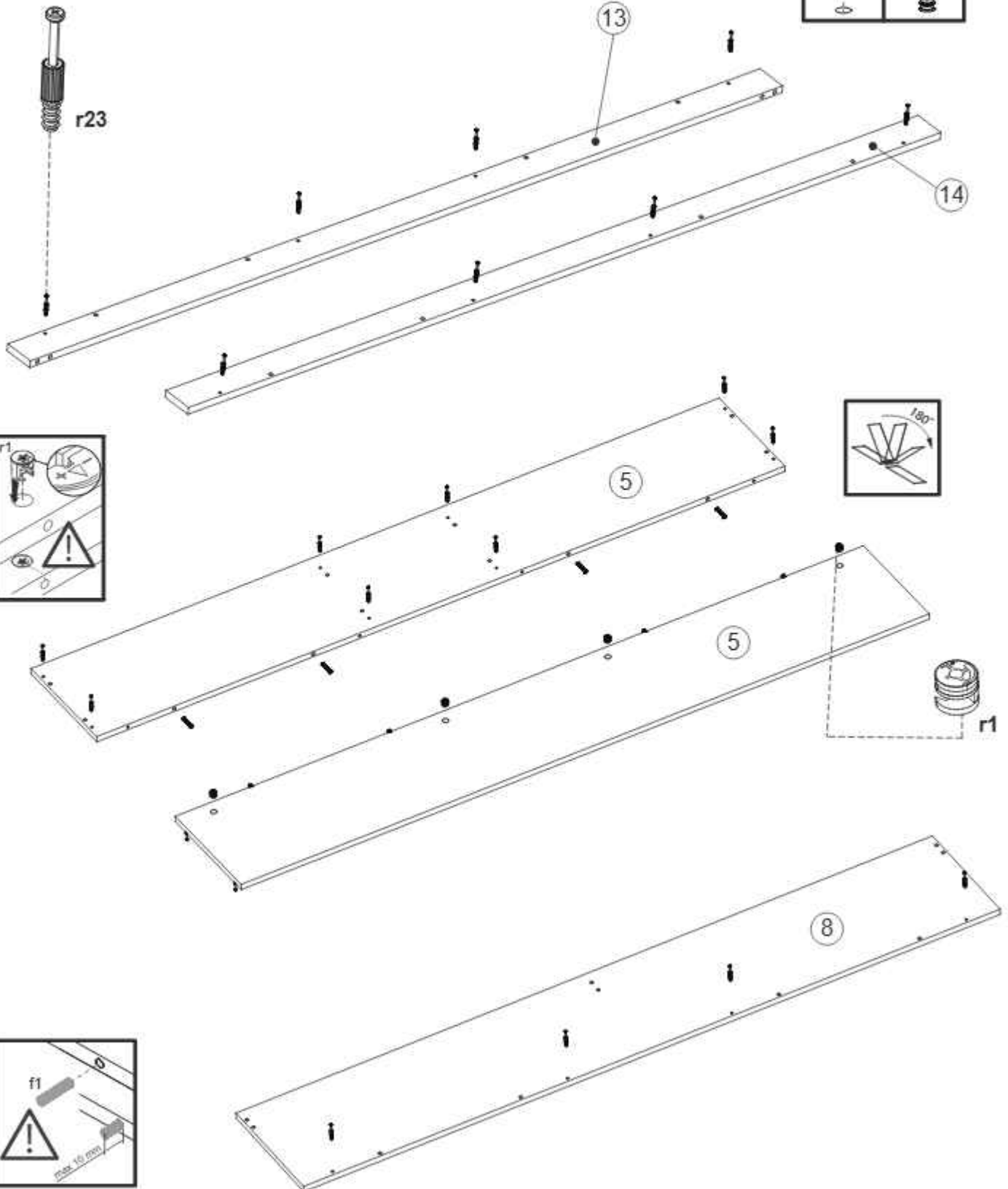

4

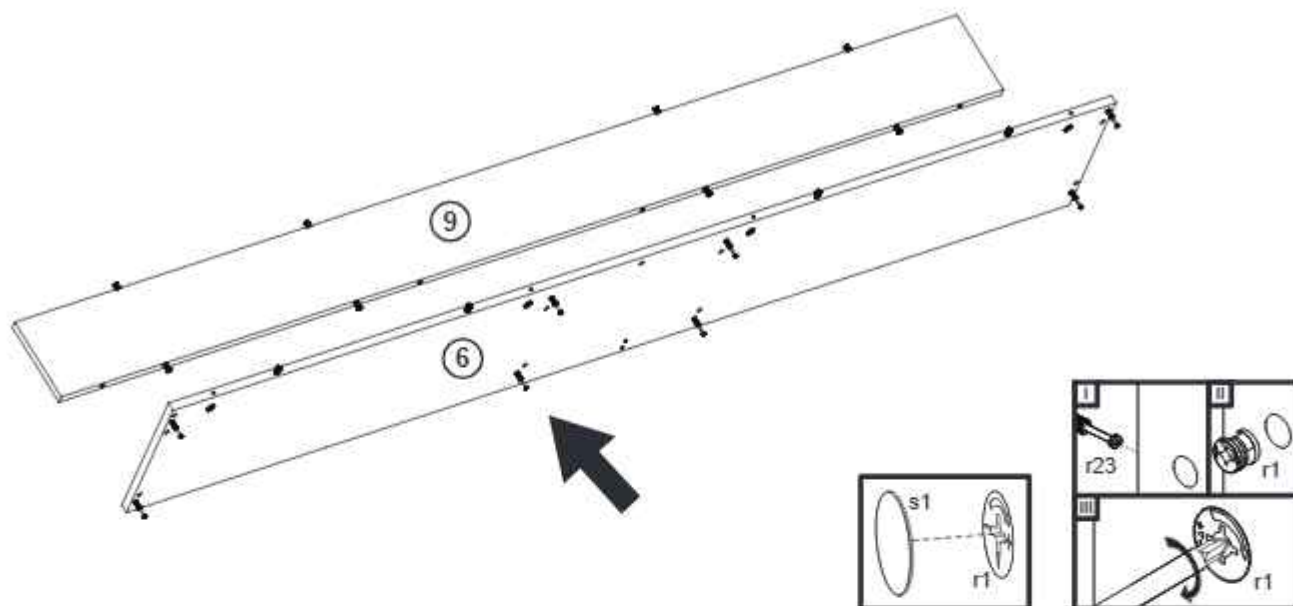

5

e27 x 3



z1 x 1

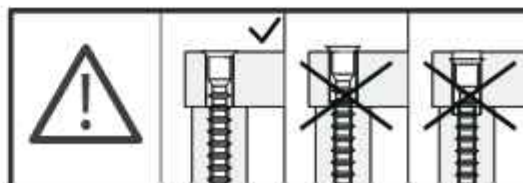
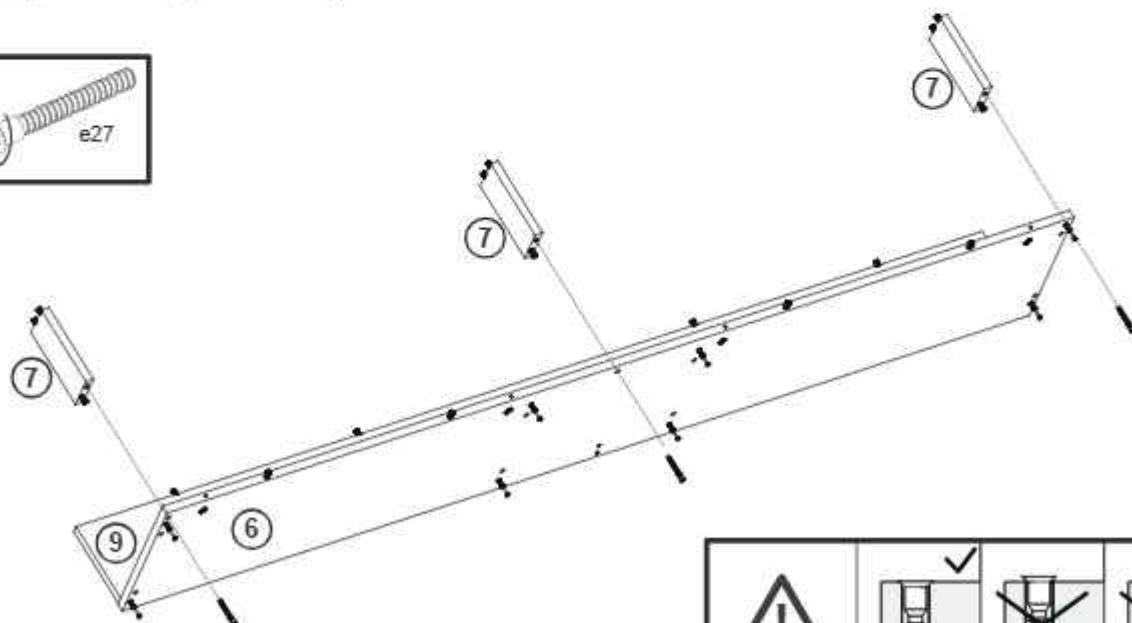
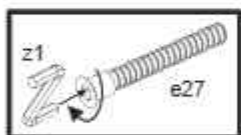

6

s1 x 4



Ø 20mm

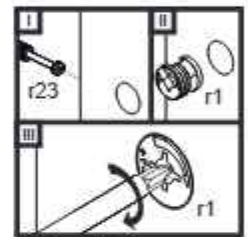
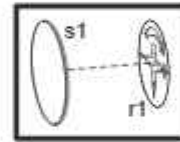
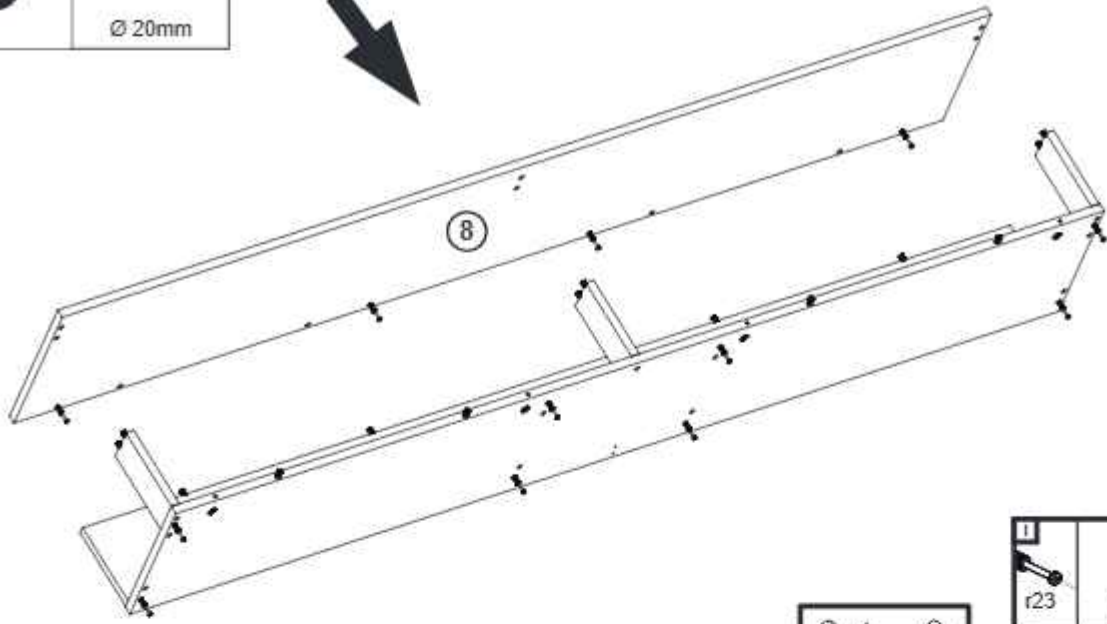

7

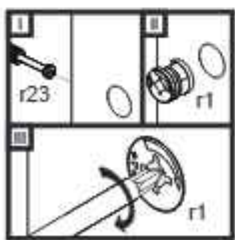
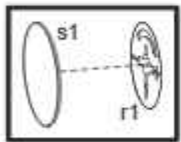
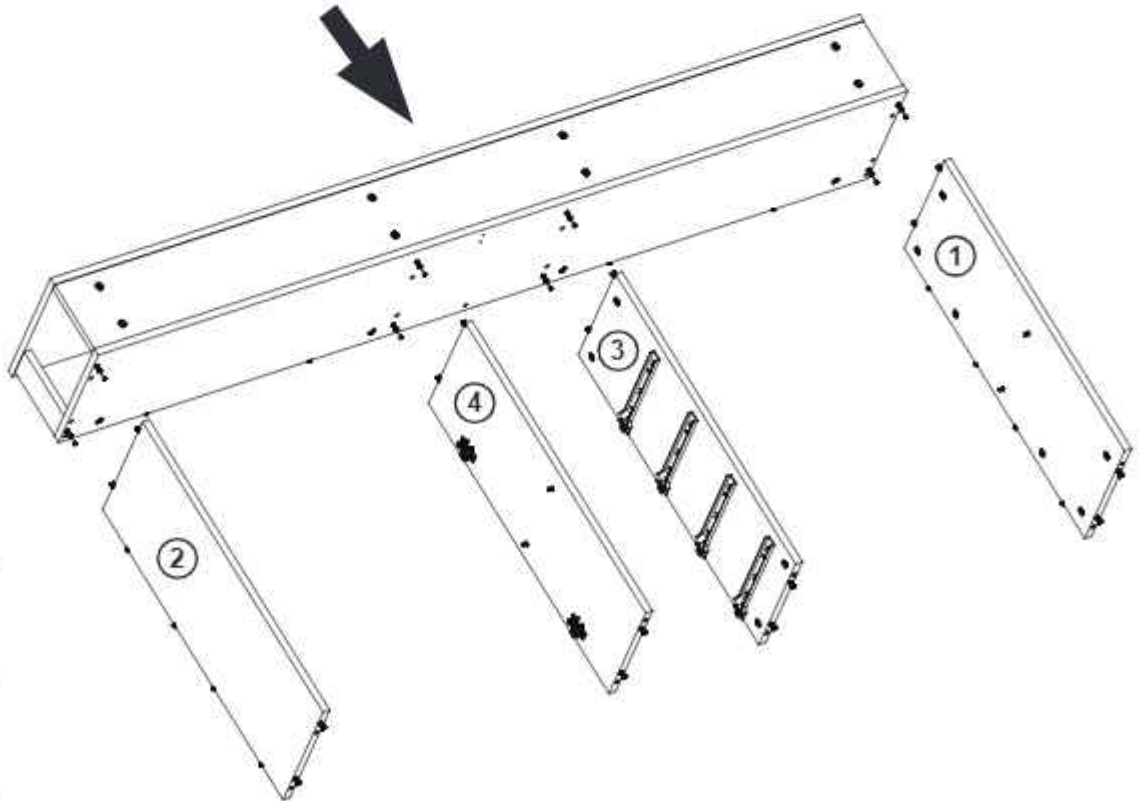

8

s1 x 8



Ø 20mm

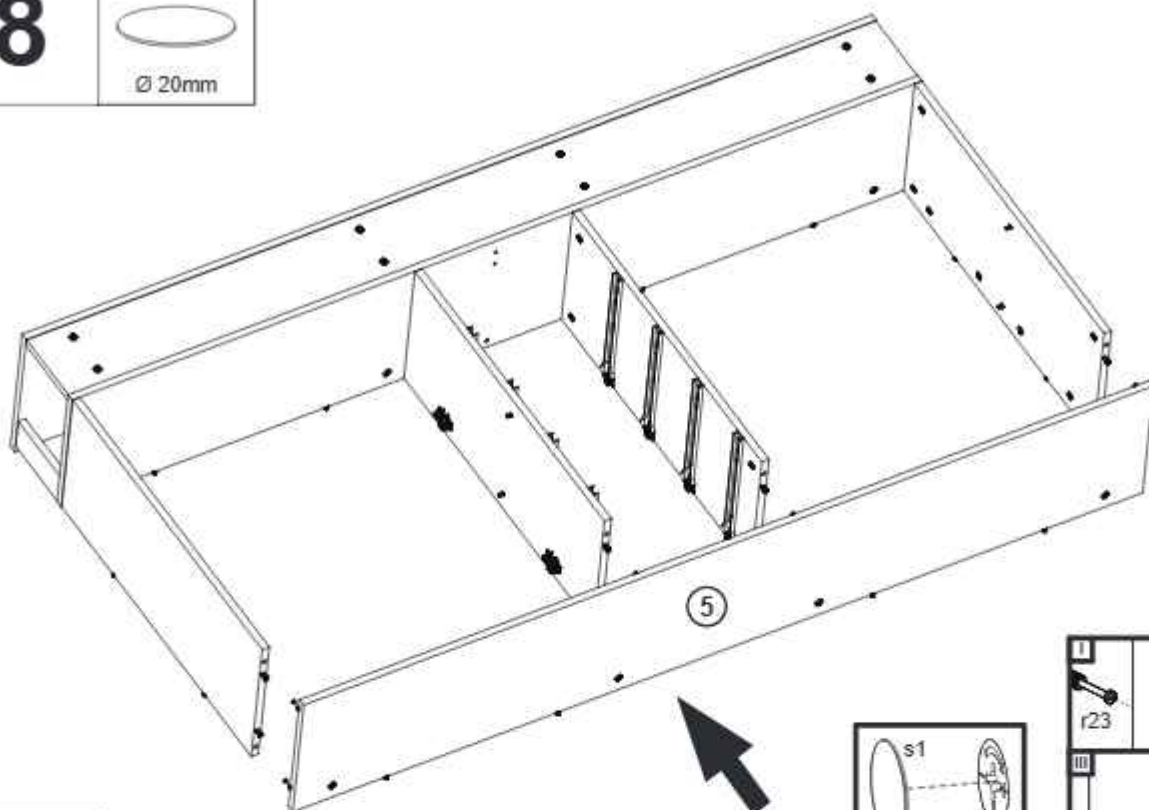

9

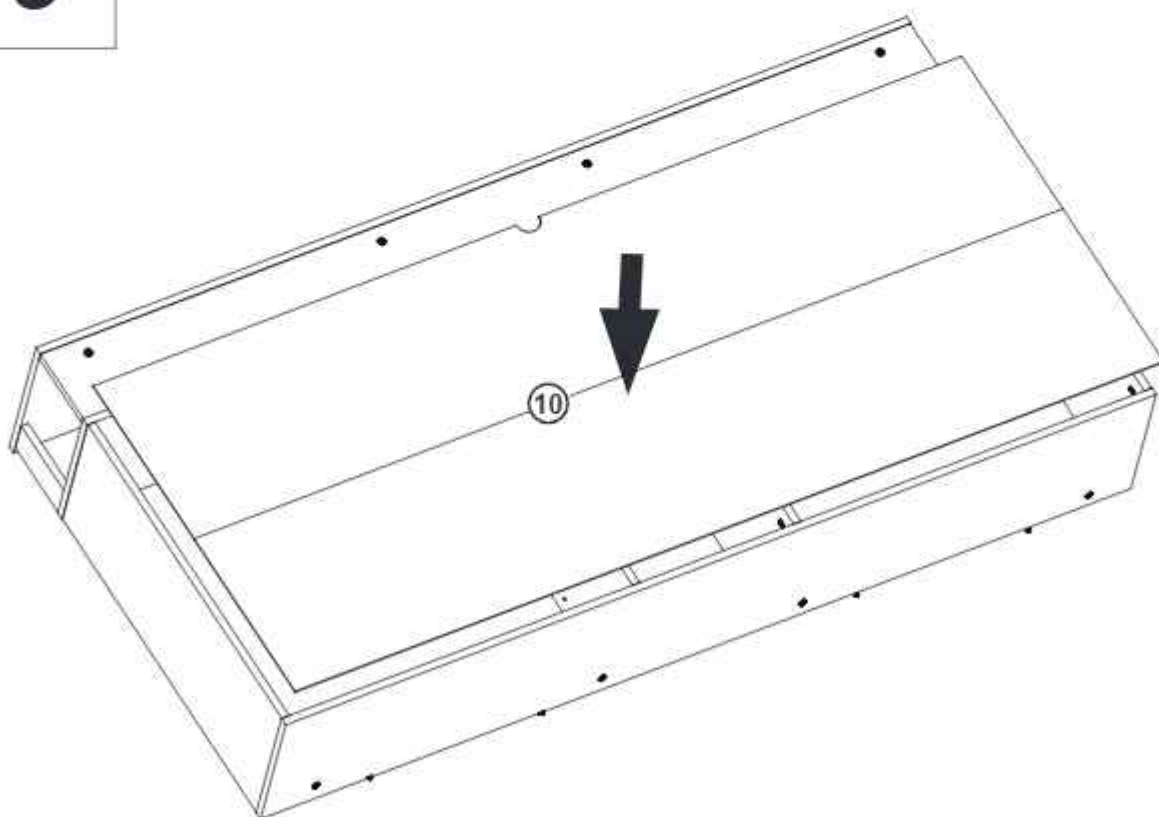
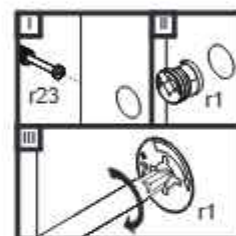
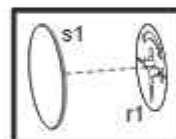

10

g1 x 80



Ø 2x20mm

k44 x 6



15x45x45mm

p27 x 6



Ø 4x20mm

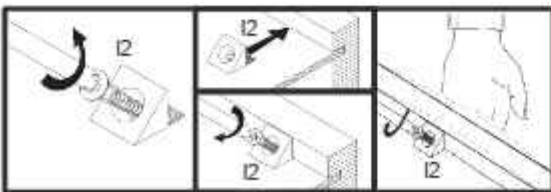
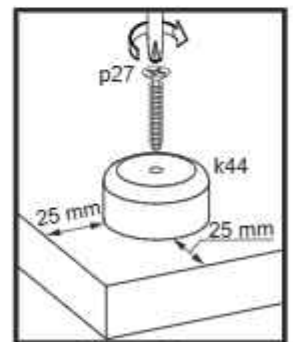
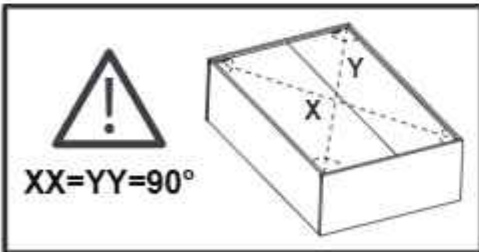
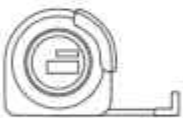
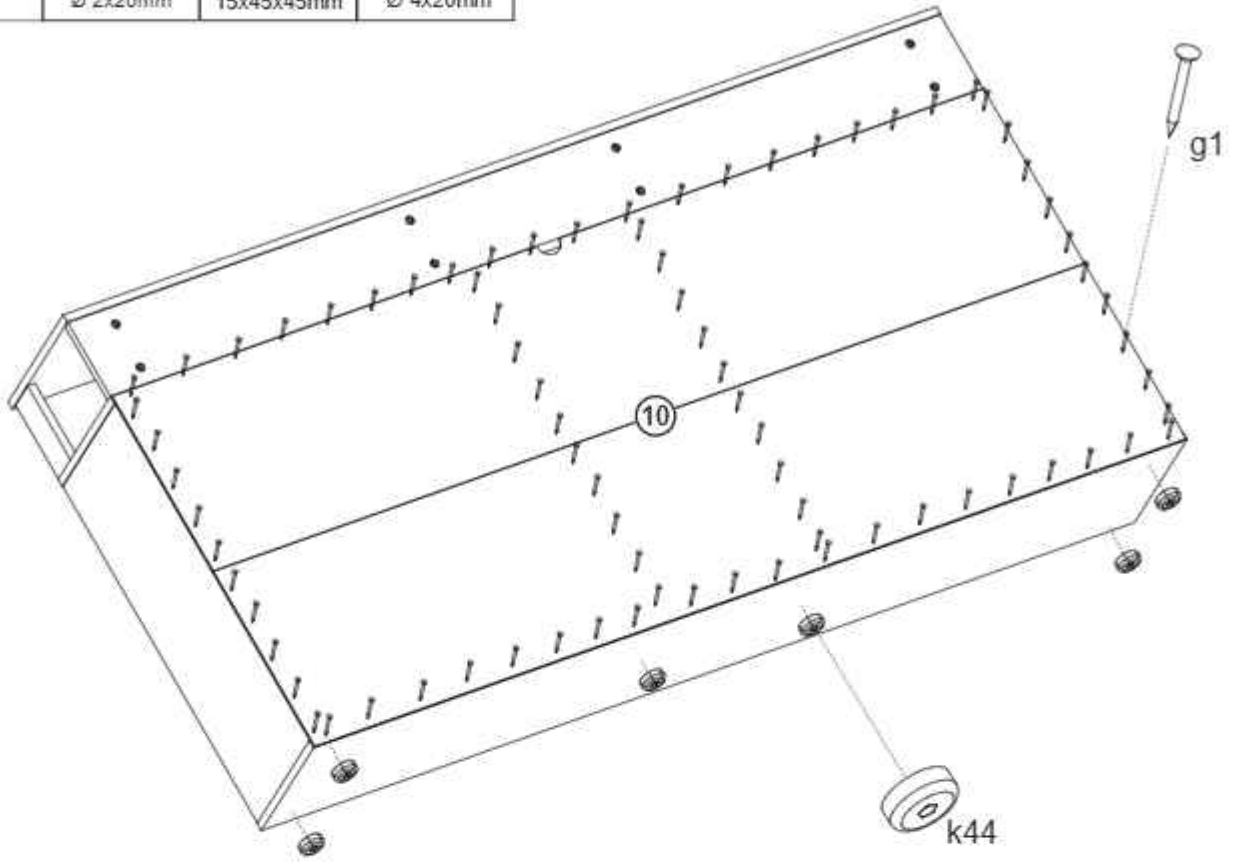

11

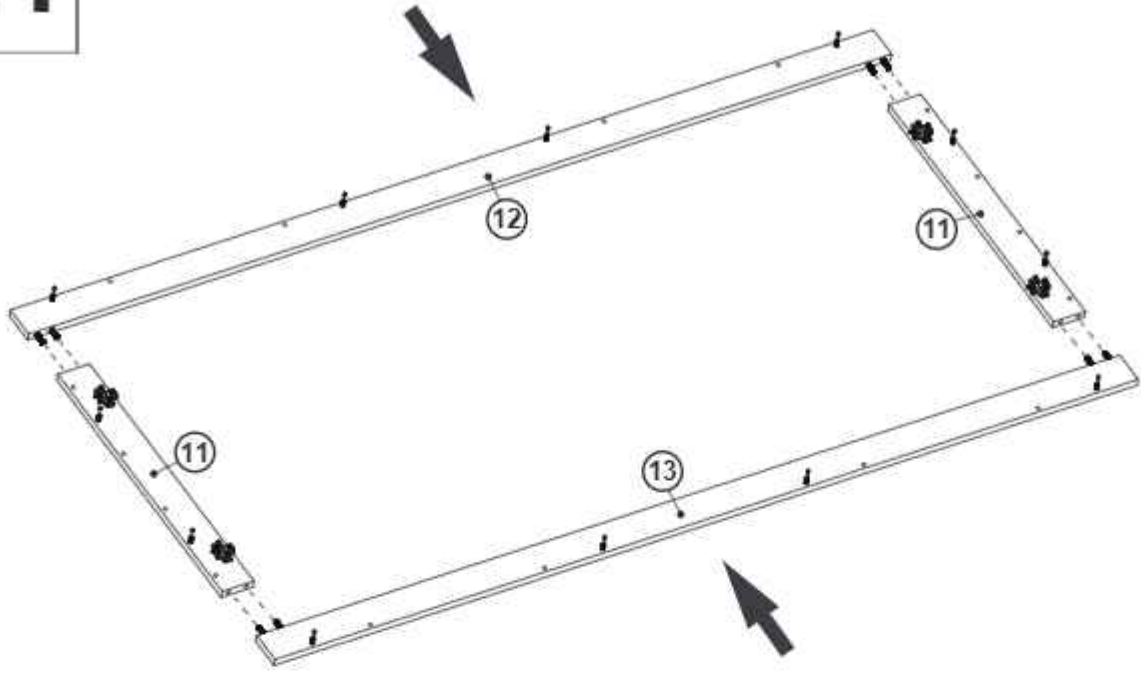

12

s1 x 12



∅ 20mm

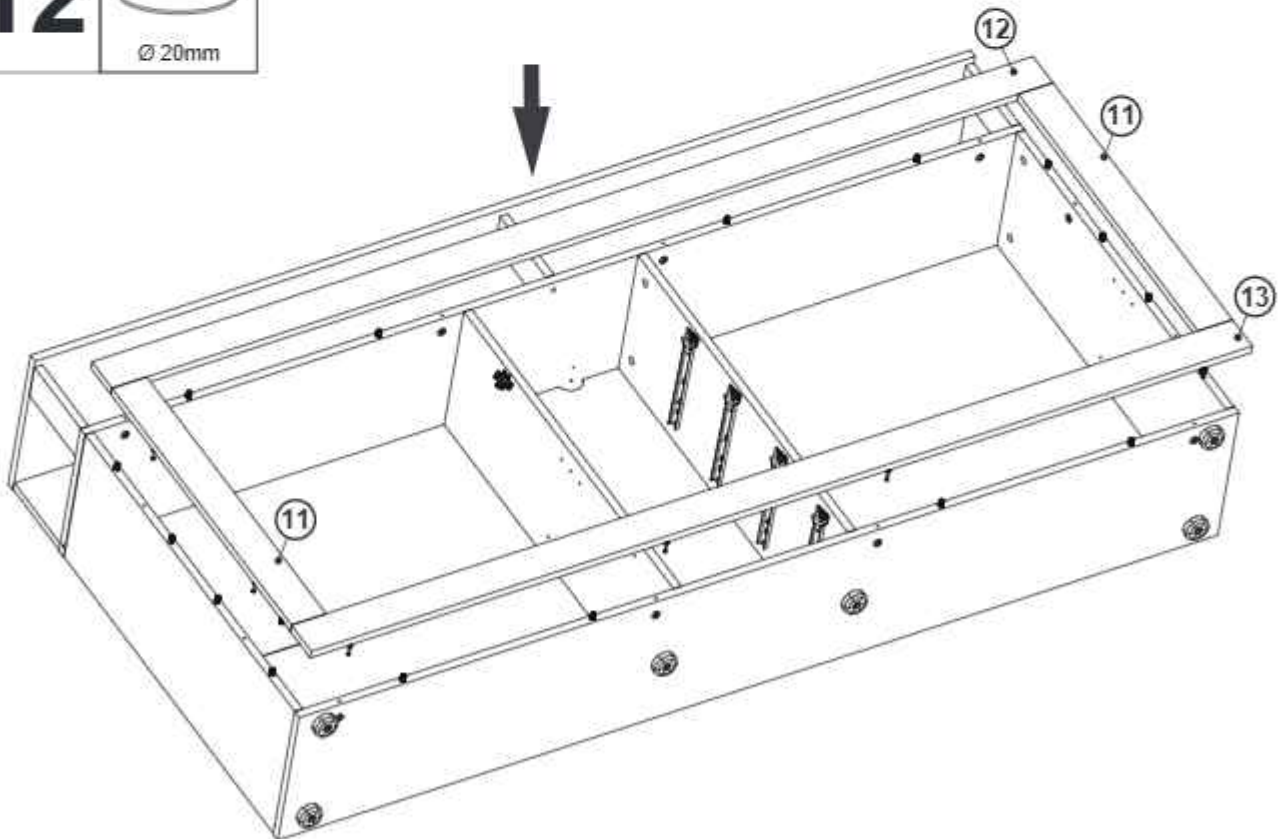

13

r1 x16



Ø 15x12mm

r23 x 16



45mm

p36 x 8



Ø 4,2x32mm

c237 x 4



L=128mm

e27 x 16



Ø 6,3x50mm

z1 x 1



4mm

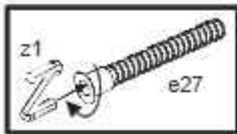

e27

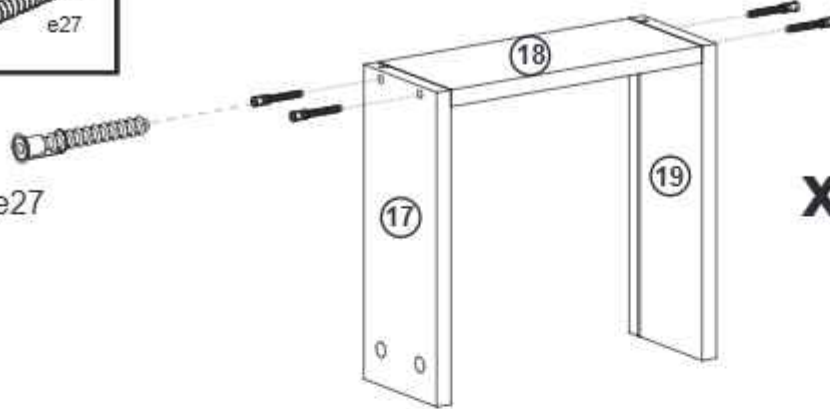

x4

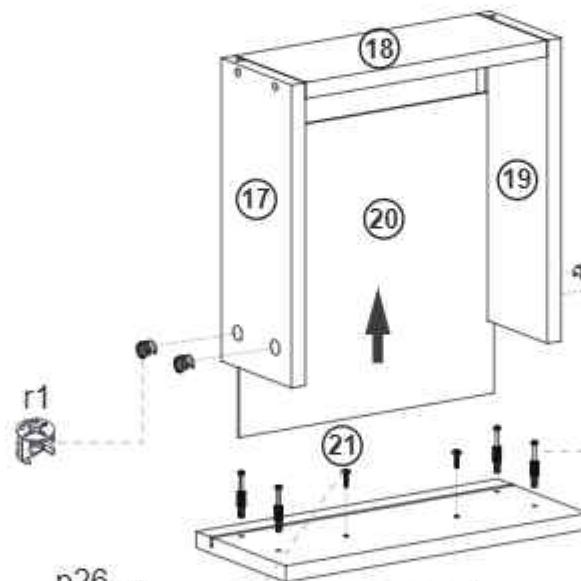
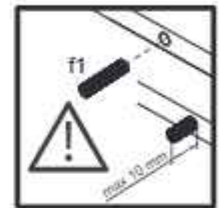

x4

r23

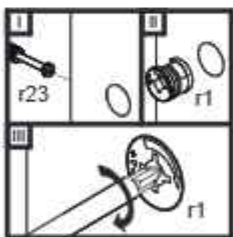
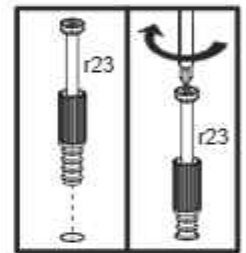

p26



c237

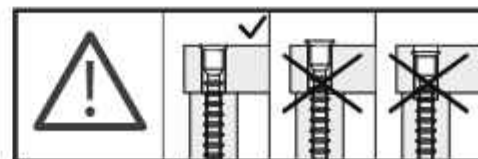
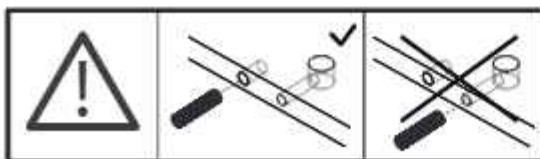
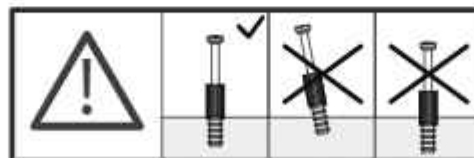

14

p50 x 16



Ø 3x16mm

n1/2 x 4



L=300mm

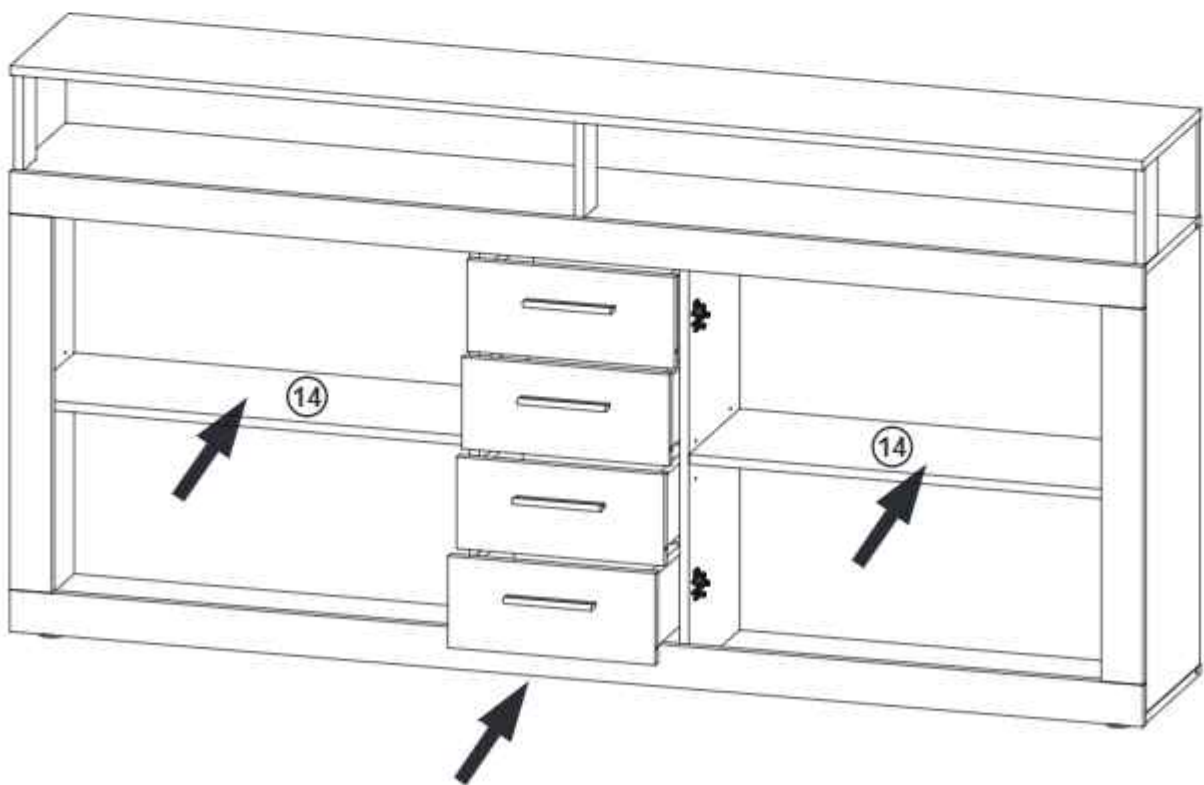
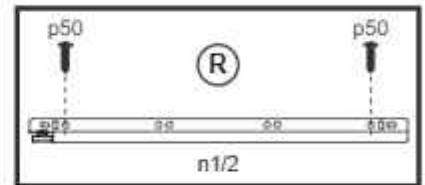
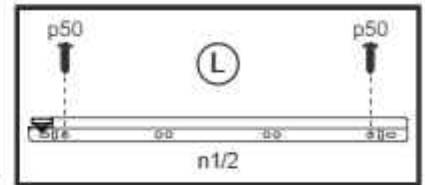
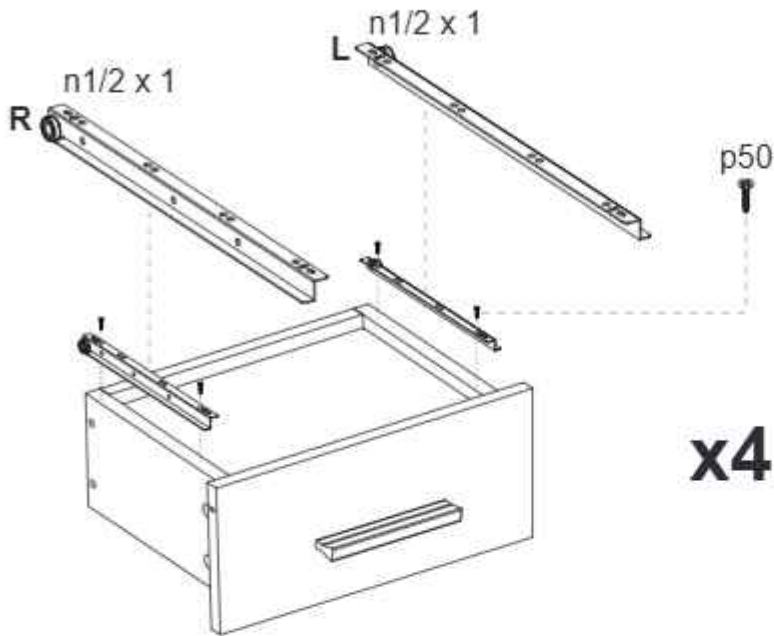

15

p63 x 8



Ø 4,2x32mm

p51 x 16



Ø 3,5x16mm

a2 x 4



Ø 35mm

a3 x 4



Ø 35mm

c237 x 4



L=128mm

s7 x 8



L=96/128mm

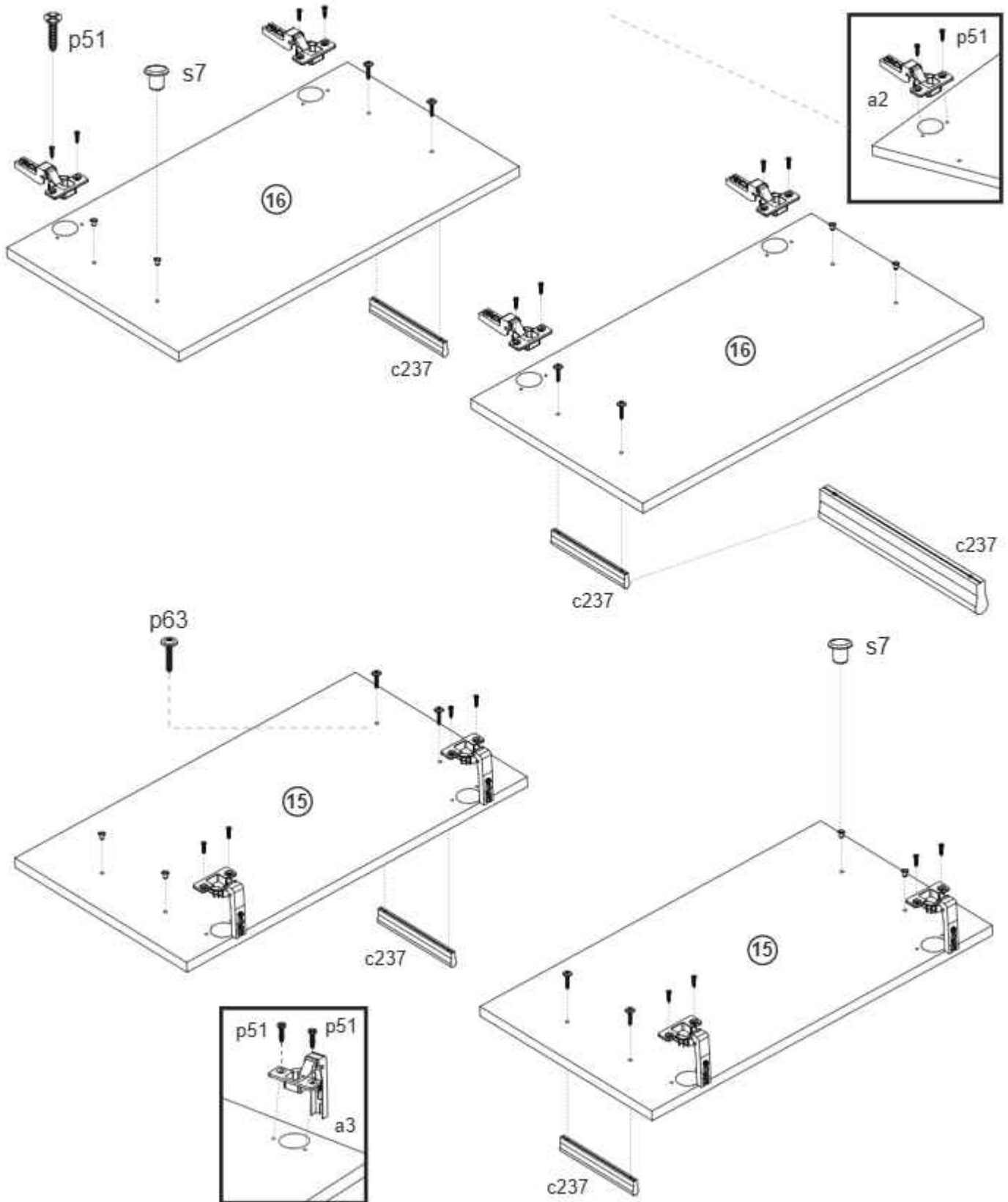

16

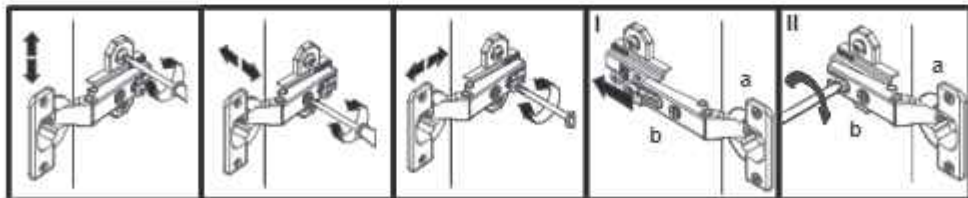
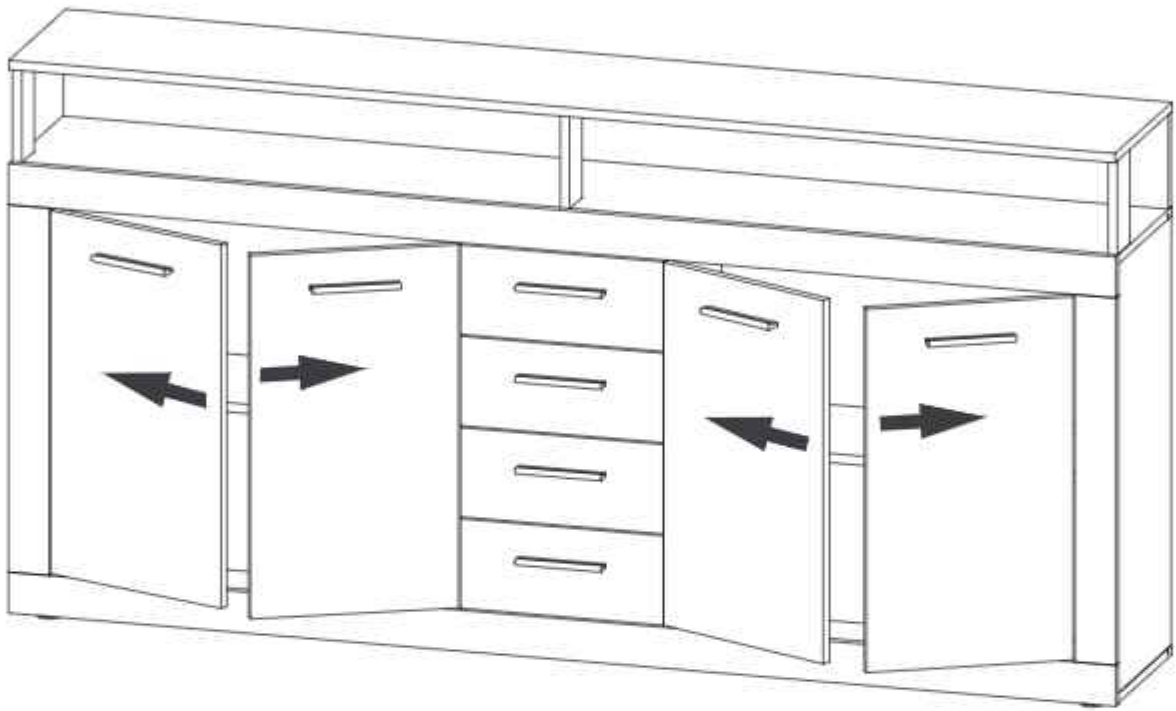

17

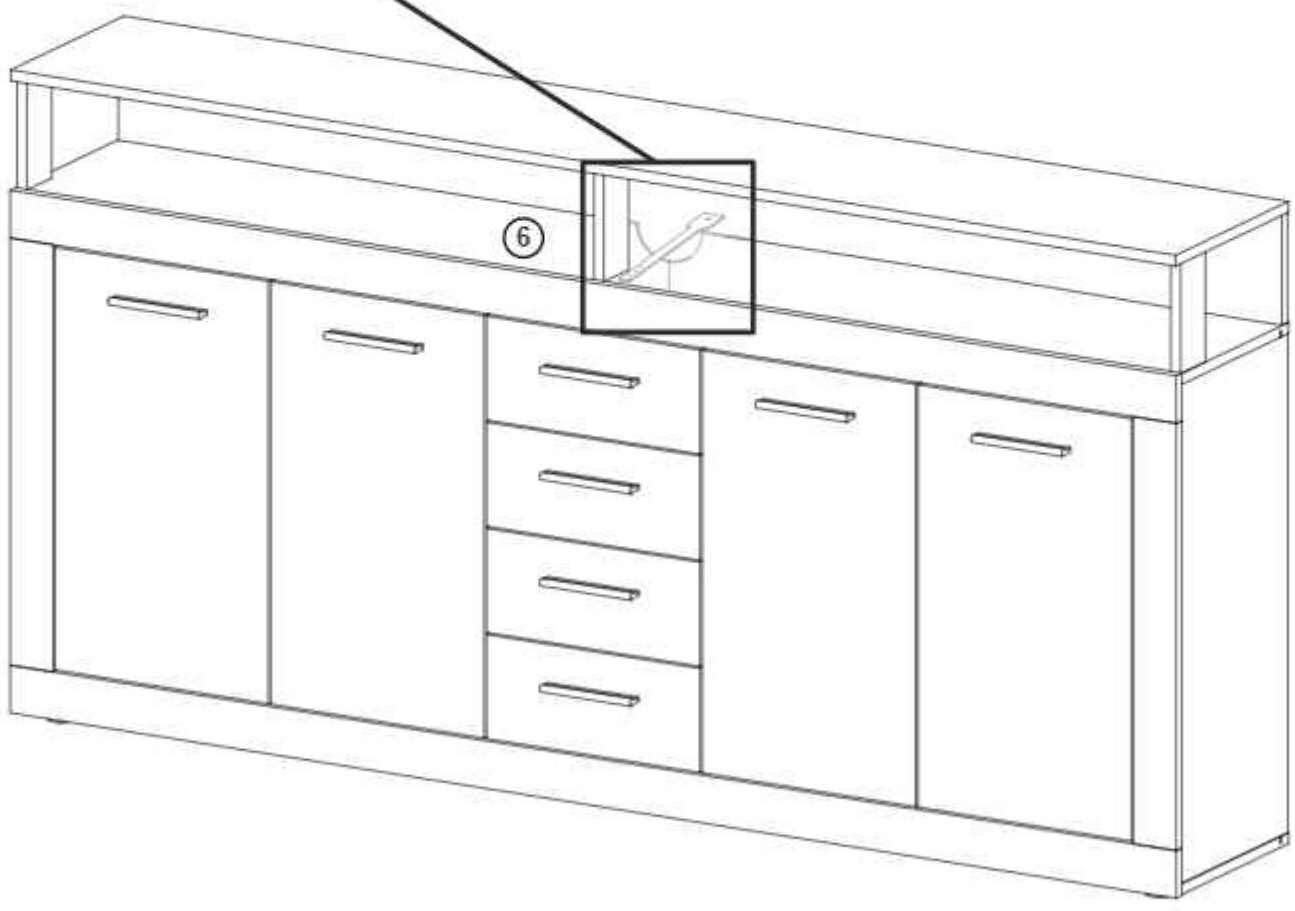
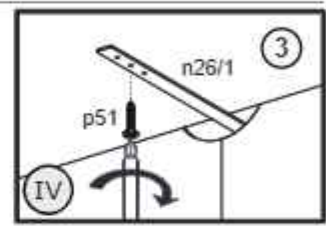
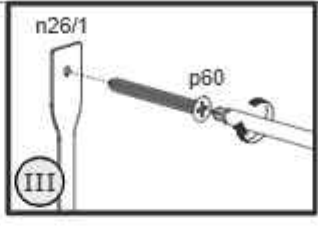
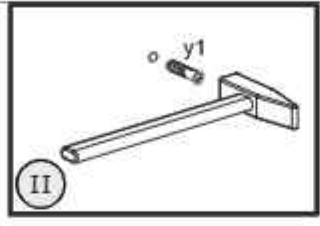
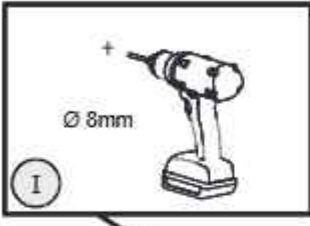

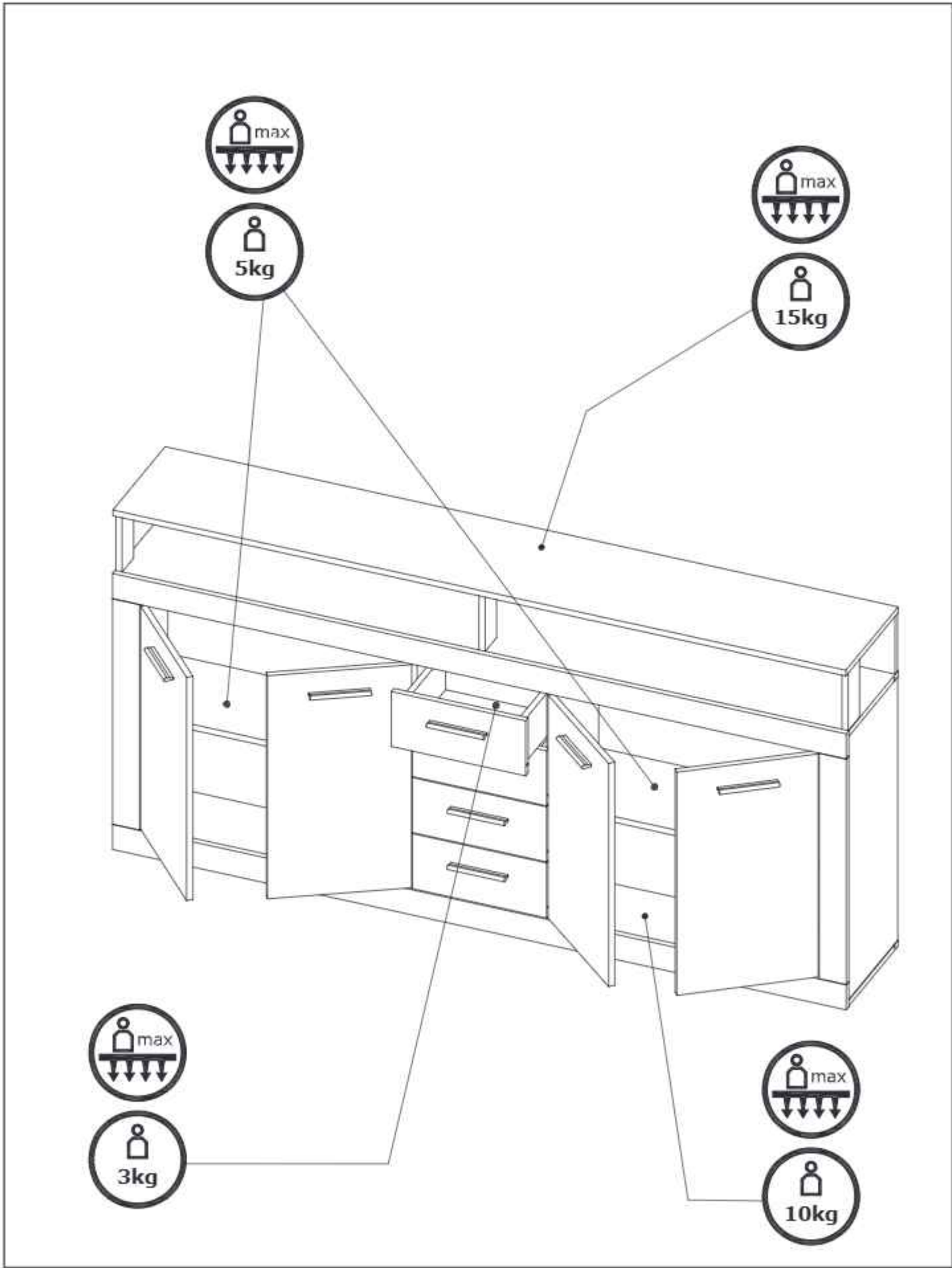

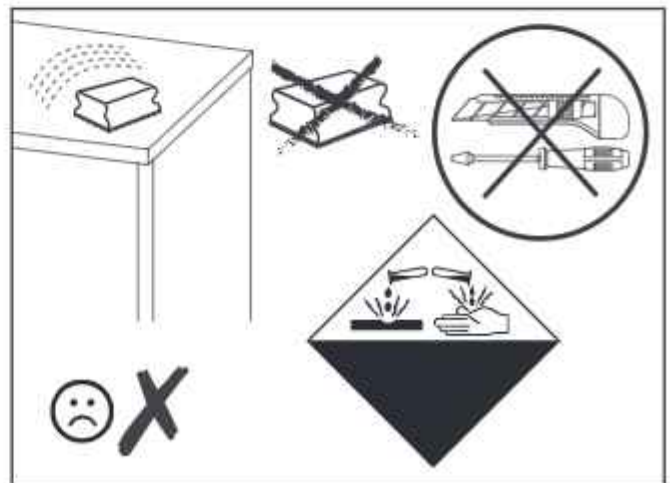
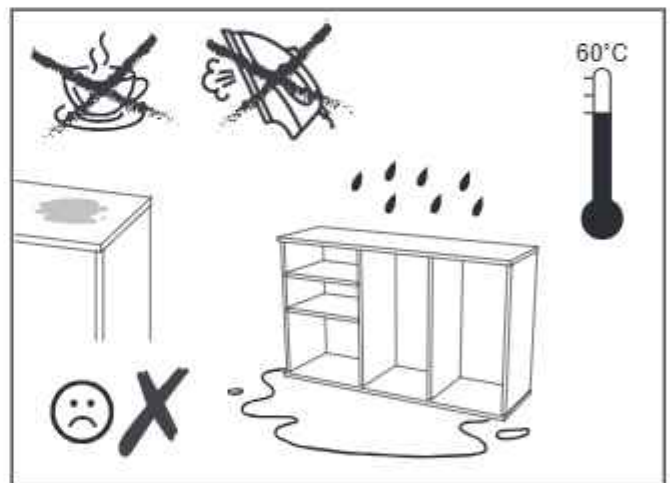
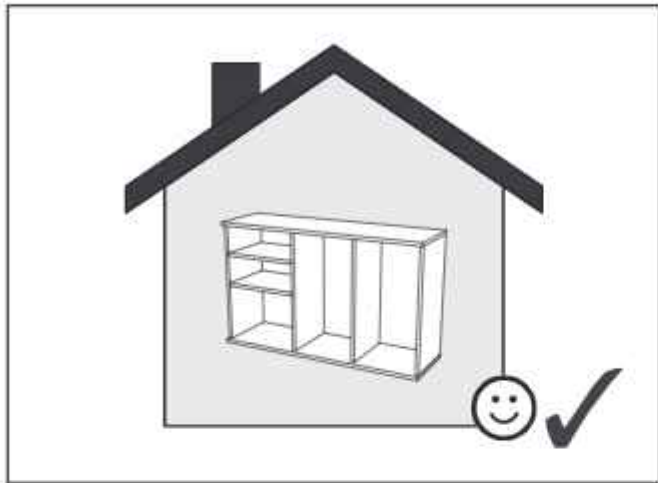

- PL** Powierzchnię mebli należy czyścić tylko środkami do pielęgnacji mebli. Szanowny kliencie w przypadku reklamacji prosimy wypełnić druki reklamacyjne dostępne w punktach sprzedaży przedkładając Kartę Reklamacyjną (zawierającą datę produkcji i numer pakowacza lub zmiany pakowania) umieszczona w każdej z paczek, oraz instrukcję montażu mebla, gdzie prosimy o zaznaczenie uszkodzonego elementu.
- SK** Povrch nábytku čistite iba prostriedkami určenými na ošetrovanie nábytku. Vá ení zákazníci! V prípade reklamácie prosíme, aby ste vyplnili tlačivá, ktoré sú prístupné v obchodoch, predlo ili Reklamačný list (ktorý obsahuje dátum výroby a číslo baliča alebo číslo zmeny pri balení), ktorý sa nachádza v ka dom balení a návod na montá nábytku, v ktorom označte poškodenú čas.
- CZ** Povrch nábytku čistíte pouze přípravky určenými k ošetřování nábytku. Vá ený zákazník, v případě uplatnění reklamacce vyplňte prosím reklamační formuláře, které jsou dostupné v prodejnách a předlo te Reklamační kartu (obsahující datum výroby a číslo balení nebo změny balení, která je umístěna v balíčku) a návod k obsluze s vyznačením poškozeného dílu.
- BG** Повърхността на мебелите трябва да се почиства само с препарати за поддържане на мебели. Уважаеми клиенти, в случай на reclamaция моля попълнете формулярите за reclamaция, които ще получите в търговските пунктове, като представите Kartata за reclamaция (съдържаща датата на производство и номера на опаковчика или смяната за опаковане), която ще намерите във всяка опаковка, и инструкцията за монтаж на мебела, върху която да отбележите повредения елемент.
- RO** Suprafața ei trebuie să fie curățată numai cu substanțe destinate pentru curățarea mobilei. Stimată Cumpărător, în caz de reclamație vă rugăm să completați formularul de reclamație pe care îl puteți lua de la punctul de vânzare și pe care îl veți prezenta împreună cu Cartela de Garanție (care conține data producției și nr ambalatorului sau turei de ambalare), însoțită la fiecare ambalaj, precum și instrucțiunile de montaj ale mobilei, pe care vă rugăm să marcați elementul deteriorat.
- UA** Поверхню меблів потрібно чистити тільки засобами для догляду за меблями. Шановний клієнте для заяви рекламачії, просимо заповнити формуляр рекламачії, доступний у пунктах продажу, вказуючи рекламачійну карту (містить дату виробництва та номер пакувальника або зміни упаковки), прикладену до кожного пакету, а також інструкцію з монтажу меблів, на якій просимо позначити пошкоджений елемент.
- RUS** Поверхность мебели надо чистить только средствами для ухода за мебелью. Уважаемый клиент для заявления рекламации, просим заполнить формуляр рекламации, доступный в пунктах продажи, указывая Рекламационную карту (содержащую дату производства и номер упаковщика или смены упаковки), приложенную к каждому пакету, а также инструкцию по монтажу мебели, на которой просим обозначить поврежденный элемент.
- DE** Reinigen Sie den Möbelbereich nur mit Möbelpflege. Kunden, bei Beanstandung Bitte füllen Sie die Reklamationsformulare, die in den Verkaufsabteilungen erhältlich sind, vor dem Verkauf aus eine Reklamationskarte (mit Angabe des Produktionsdatums und der Anzahl der Personen, die die Waren verpacken, oder der Anzahl der Schichten) Verpackung), die in jeder Packung enthalten ist, und Halterungen, in denen Sie reichlich vorhanden oder beschädigt sind Elemente Reinigen Sie den Möbelbereich nur mit Möbelpflege. Kunden, bei Beanstandung.
- GB** Furniture surface must be cleaned only with furniture maintenance formulas. Dear Customer, should you wish to file a complaint, we would request you to fill in the complaint forms available in our outlets, submitting the Complaint Card (specifying the date manufactured, packaging employee/ shift code) enclosed in each of the packets, together with the Assembly Manual, where please highlight the faulty component.
- H** A bútorok felületét kizárólag a bútorápolószerekkel lehet tisztítani. Tisztelt Vásárló! Reklamáció esetén kérjük az eladási helyeken kapható reklamációs nyomtatványokat kitölteni a Reklamációs Lap (tartalmazza a gyártási dátumát és csomagoló számát vagy műszakszámát) bemutatásával, amely mindegyik csomagban található, valamint a bútor szerelési utasítását, amelyen kérjük a sérült elemet bejelölni szíveskedjék.
- FR** La surface des meubles ne peut être nettoyée qu'avec des produits pour l'entretien de meubles. Cher Client, en cas de réclamation, veuillez bien remplir des formulaires de réclamation accessibles dans les centres de vente en montrant le mode d'emploi pour monter le meuble. Nous vous demandons de bien vouloir y entourer l'élément en panne.
- ES** Limpiar la superficie de muebles exclusivamente con los agentes para el cuidado de los muebles. Estimado Cliente, en caso de reclamaciones, hagan favor de rellenar los formularios de reclamación disponibles en los puntos de venta, presentando las instrucciones de montaje de mueble, donde es necesario indicar un elemento estropeado.