

N625P402474

N625P402475

Product manual
Gebrauchsanweisung
Manuel du produit
Manual del producto
Manuale del prodotto

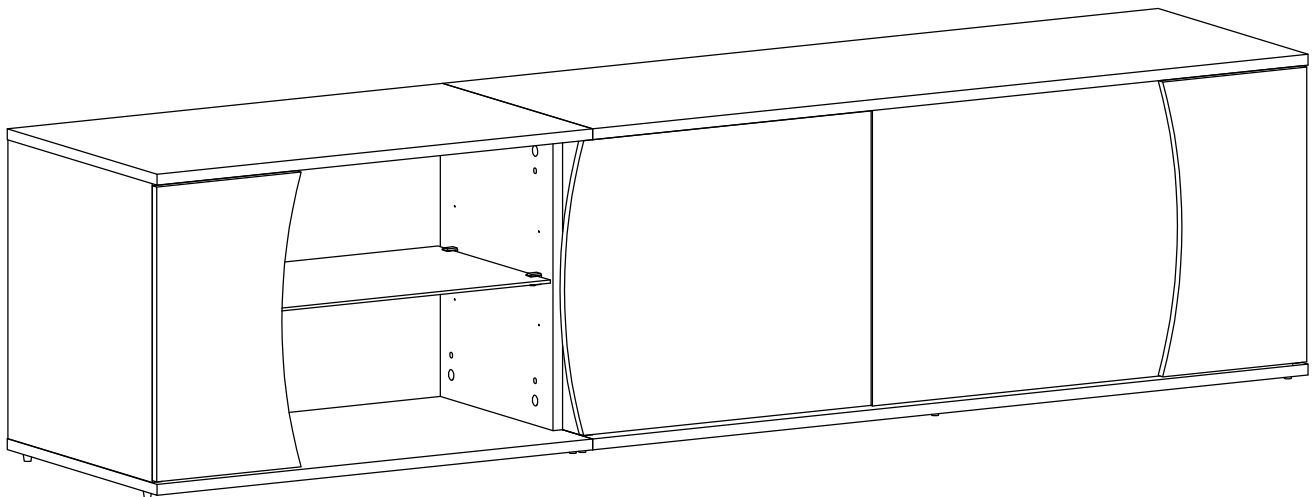

EN:Our product will be delivered to you in 2 packages.The delivery times of these 2 packages may differ, please be patient and thank

you for your understanding

FR:Notre produit vous sera livré en 2 colis.Les delais de livraison de ces 2 colis peuvent différer,soyez patient et merci de votre compréhension.

DE:Unser Produkt wird Ihnen in 2 Paketen geliefert.Die Lieferzeiten dieser 2 Paketekonnenabweichen,bitte







haben Sie etwas Geduld und vielen Dank fur Ihr Verstandnis

IT:I nostri prodotti vengono trasportati in due pacchetti. I tempi di consegna dei due pacchetti sono diversi abbiate pazienza e vi ringrazio per la vostra comprensione.

ES:Nuestro producto se entrega en dos paquetes. El tiempo de entrega de estos dos paquetes es diferente. Por favor, sea paciente. Gracias por su comprensión.

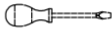

Points de collecte sur www.quefairedemesdechets.fr
Privilégiez la réparation ou le don de votre appareil !

 2PERS	 45 MIN	Tool Required Not Provided	
			
			



[DE]

Warnung: Lesen Sie die Anleitung vor dem Zusammenbau bitte vollständig durch. Überprüfen Sie, ob Sie alle auf den Seiten aufgeführten Komponenten und Werkzeuge haben.

Warnung: Legen Sie alle Teile auf eine ebene Fläche. Legen Sie eine weiche Decke oder Ähnliches darunter, um sie vor Kratzern oder Flecken zu schützen. Vermeiden Sie es, Komponenten über den Boden zu ziehen oder zu schieben.

Warnung: Überprüfen Sie regelmäßig alle Beschläge und Befestigungen, um sicherzustellen, dass sie sicher sind und um Unfälle zu vermeiden. Wenn Teile fehlen, kaputt, beschädigt oder abgenutzt sind, verwenden Sie das Produkt nicht weiter, bis es mit vom Hersteller autorisierten Teilen repariert wurde.

Warnung: Lassen Sie Kinder nicht auf die Möbel klettern, da dies zum Umkippen und zu schweren Verletzungen führen kann. Bauen Sie die Möbel außerhalb der Reichweite von Kindern zusammen.

Warnung: Stellen Sie die Möbel nicht in die Nähe von Feuerquellen oder heißen Gegenständen, um Brandgefahr zu vermeiden.

Warnung: Reinigen Sie die Möbel mit einem feuchten Tuch oder Alkohol. Verwenden Sie keine Reinigungsmittel mit ätzenden Chemikalien.

Warnung: Dieses Produkt ist mit einer Kippschutzvorrichtung ausgestattet. Bitte installieren Sie diese Vorrichtung unbedingt, um unnötige Verletzungen durch Umkippen zu vermeiden.

[EN]

Warning: Please read instructions fully before starting assembly. Check you have all the components and tools listed on pages.

Warning: Please place all parts on a flat surface. Place a soft blanket or similar underneath to protect against scratches or stains. Avoid dragging or sliding components across the floor.

Warning: Regularly check all fittings and fastenings to ensure they are secure and to prevent accidents. If any parts are missing, broken, damaged, or worn, discontinue use of the product until repairs have been made using factory authorized parts.

Warning: Do not allow children to climb on the furniture as this may result in tipping and serious personal injury. Assemble the furniture away from the reach of children.

Warning: Do not place furniture close to fire sources or high-temperature objects to avoid the risk of fire.

Warning: Clean furniture with a damp cloth or alcohol, avoid using cleaning agents containing corrosive chemicals.

Warning: This product is equipped with an anti-tilt device. Please be sure to install this device to prevent unnecessary injuries caused by tipping.

[FR]

Avertissement : Veuillez lire entièrement les instructions avant de commencer l'assemblage. Vérifiez que vous disposez de tous les composants et outils répertoriés sur les pages.

Avertissement : Veuillez placer toutes les pièces sur une surface plane. Placez une couverture douce ou similaire en dessous pour les protéger des rayures ou des taches. Évitez de faire glisser les composants sur le sol.

Avertissement : Vérifiez régulièrement tous les raccords et fixations pour vous assurer qu'ils sont bien fixés et pour éviter les accidents. Si des pièces manquent, sont cassées, endommagées ou usées, cessez d'utiliser le produit jusqu'à ce que des réparations aient été effectuées à l'aide de pièces autorisées par l'usine.

Avertissement : Ne laissez pas les enfants grimper sur les meubles car cela pourrait entraîner un basculement et des blessures graves. Assemblez les meubles hors de portée des enfants.

Avertissement : Ne placez pas les meubles à proximité de sources de feu ou d'objets à haute température pour éviter tout risque d'incendie.



Avertissement : Nettoyez les meubles avec un chiffon humide ou de l'alcool, évitez d'utiliser des produits de nettoyage contenant des produits chimiques corrosifs.

Avertissement : Ce produit est équipé d'un dispositif anti-basculement. Assurez-vous d'installer ce dispositif pour éviter les blessures inutiles causées par un basculement.

[IT]

Attenzione: leggere attentamente le istruzioni prima di iniziare il montaggio. Verificare di avere tutti i componenti e gli strumenti elencati nelle pagine.

Attenzione: posizionare tutte le parti su una superficie piana. Posizionare una coperta morbida o simile sotto per proteggere da graffi o macchie. Evitare di trascinare o far scivolare i componenti sul pavimento.

Attenzione: controllare regolarmente tutti i raccordi e i dispositivi di fissaggio per assicurarsi che siano sicuri e per prevenire incidenti. Se alcune parti sono mancanti, rotte, danneggiate o usurate, interrompere l'uso del prodotto fino a quando non siano state eseguite le riparazioni utilizzando parti autorizzate dalla fabbrica.

Attenzione: non consentire ai bambini di arrampicarsi sui mobili poiché ciò potrebbe causare ribaltamenti e gravi lesioni personali. Montare i mobili lontano dalla portata dei bambini.

Attenzione: non posizionare i mobili vicino a fonti di fuoco o oggetti ad alta temperatura per evitare il rischio di incendio.

Attenzione: pulire i mobili con un panno umido o alcol, evitare di utilizzare detergenti contenenti sostanze chimiche corrosive.

Attenzione: questo prodotto è dotato di un dispositivo antiribaltamento. Assicurarsi di installare questo dispositivo per prevenire lesioni inutili causate dal ribaltamento.

[ES]

Advertencia: Lea las instrucciones completamente antes de comenzar el montaje. Compruebe que tiene todos los componentes y herramientas que se enumeran en las páginas.

Advertencia: Coloque todas las piezas sobre una superficie plana. Coloque una manta suave o algo similar debajo para protegerlas de rayones o manchas. Evite arrastrar o deslizar los componentes por el piso.

Advertencia: Verifique regularmente todos los accesorios y fijaciones para asegurarse de que estén seguros y evitar accidentes. Si falta alguna pieza, está rota, dañada o desgastada, deje de usar el producto hasta que se hayan realizado las reparaciones con piezas autorizadas de fábrica.

Advertencia: No permita que los niños se suban a los muebles, ya que esto puede provocar que se vuelquen y lesiones personales graves. Monte los muebles fuera del alcance de los niños.

Advertencia: No coloque los muebles cerca de fuentes de fuego u objetos de alta temperatura para evitar el riesgo de incendio.

Advertencia: Limpie los muebles con un paño húmedo o alcohol, evite usar agentes de limpieza que contengan químicos corrosivos.

Advertencia: Este producto está equipado con un dispositivo antivuelco. Asegúrese de instalar este dispositivo para evitar lesiones innecesarias causadas por vuelcos.

Importeur	Decobus Handel GmbH
Adresse	Innungsstraße 9,21244 Buchholz,Deutschland
Email/URL	https://www.decobusgroup.de
Hersteller	SHANDONG YIJUMUZHAI SMART HOME CO.,LTD
Adresse	1666M EAST OF JINGUANG STREETBRIDGE,LUOCHENG TOWN,SHOUGUANGCITY,WEIFANG CITY,SHANDONG PROVINCE
Email/URL	http://www.yinjumuzhai.com
Partienummer	N625P402474 N625P402475
Hergestellt in	CHINA
	Decobus Handel GmbH Innungsstraße 9,21244 Buchholz,Deutschland https://www.decobusgroup.de

Parts List

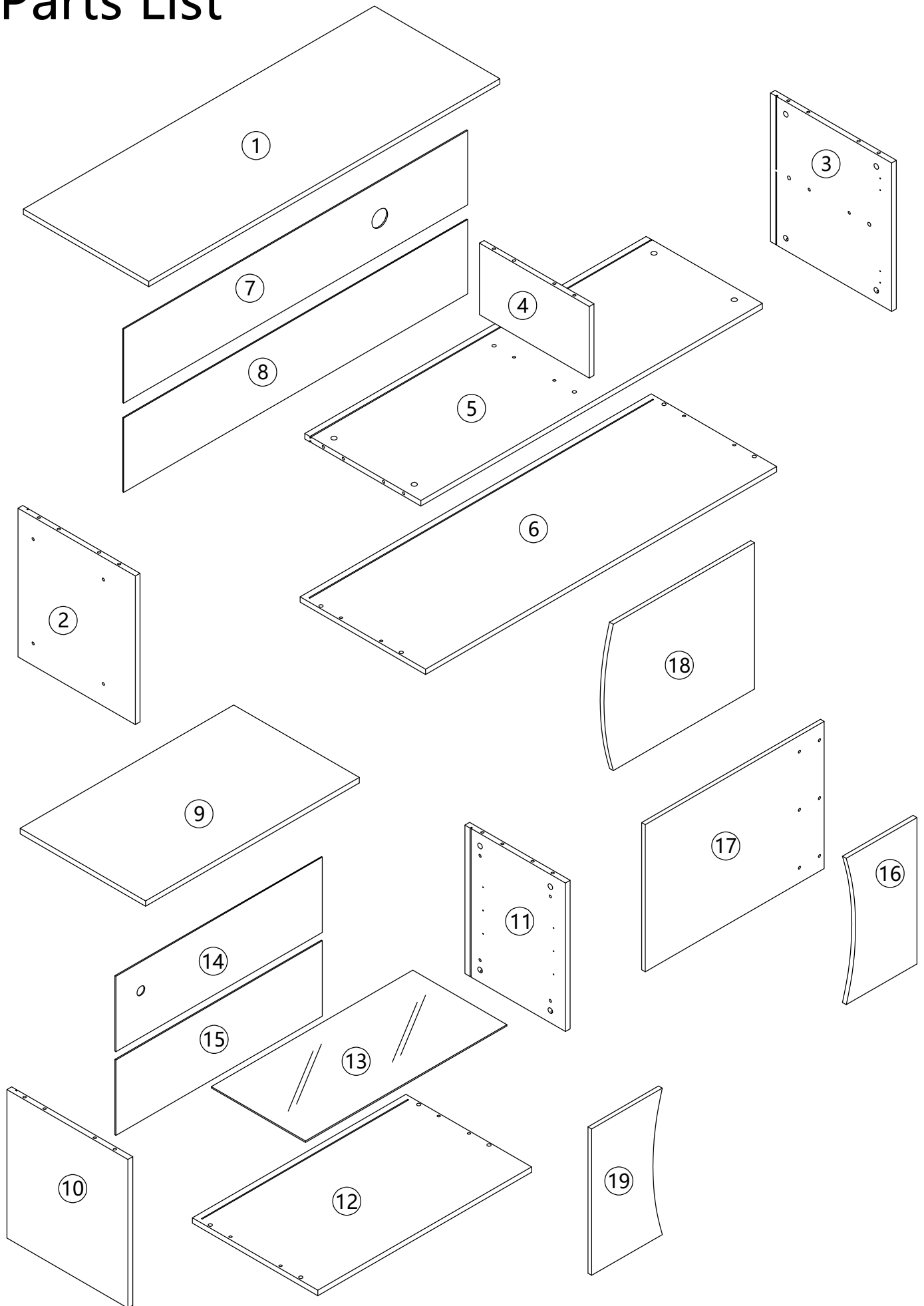

N625P402474W

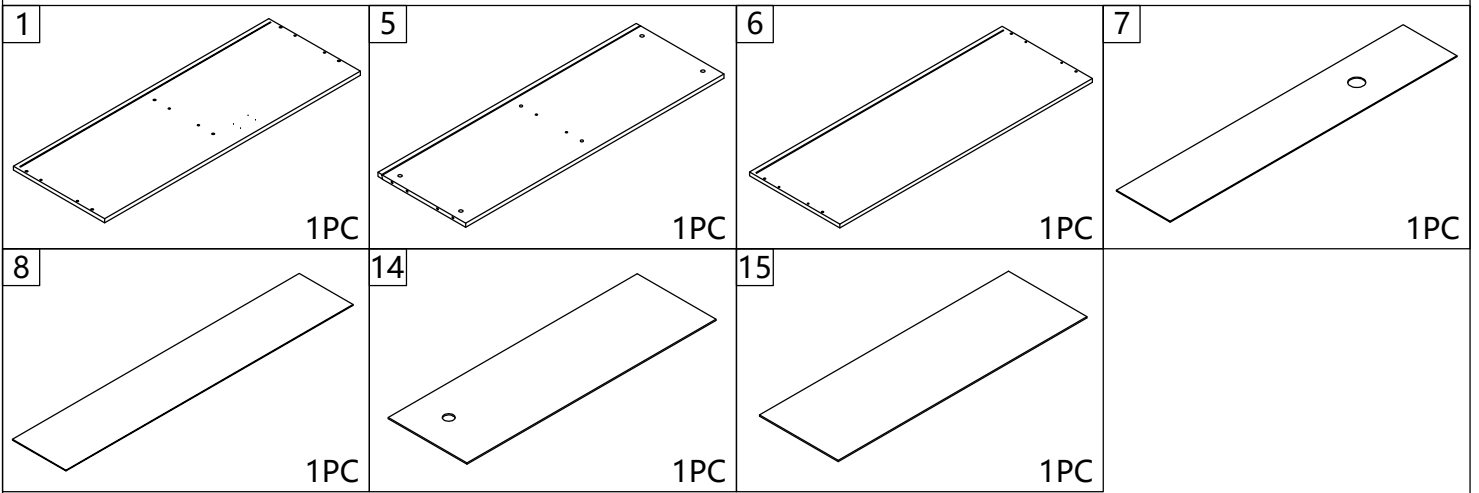

N625P402475W

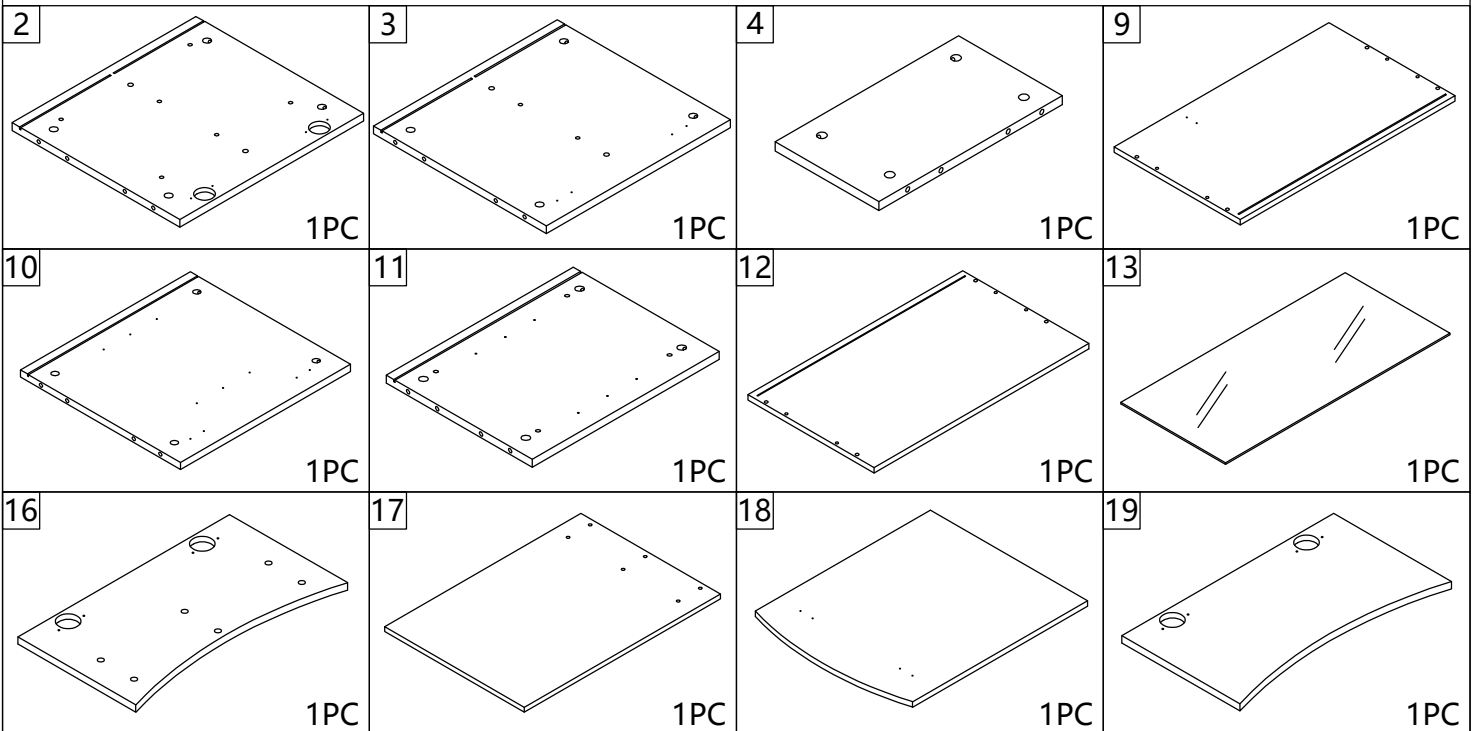

USING CAM LOCK AND QUICKFIT

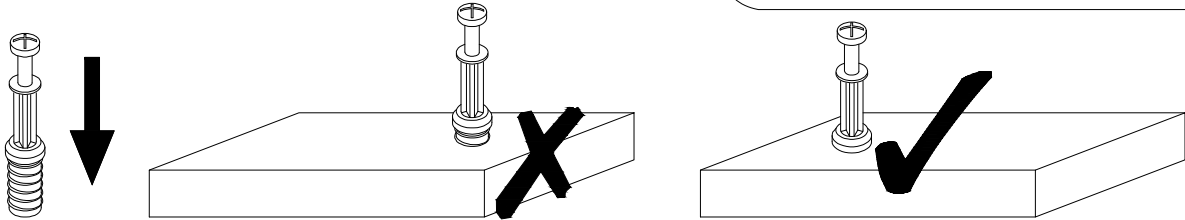

EN QUICKFIT: Tighten quickfit until shoulder is flush with panel. Do not overtighten or undertighten.

FR RACCORD RAPIDE: Faites serrer le raccord rapide jusqu'à ce que l'épaulement soit parfaitement encastré dans le panneau. Il ne faut ni trop serrer ni insuffisamment serrer.

ES QUICKFIT: Apriete quickfit hasta que el hombro se descargue con el panel. NO lo sobreapriete ni lo apriete poco.

DE QUICKFIT: Ziehen Sie den Quickfit fest, bis die Schulter mit der Platte bundig ist.

Bitte nicht zu fest oder zu schwach anziehen.

IT_MONTAGGIO RAPIDO: Stringere il montaggio rapido fino a quando la spalla è a filo con il pannello, non stringere troppo o troppo poco.

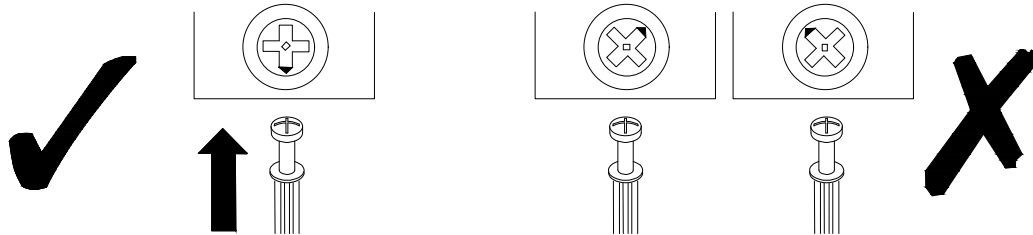

EN CAM LOCK: When fitting cam lock, ensure starting position is correct before you insert connecting quickfit.

FR SERRURE BATTEUSE: Avant d'insérer la serrure batteuse, veillez à la bonne orientation avant d'insérer le raccord rapide.

ES CIERRE DE LA CAMARA: Cuando instale el cierre de la cámara, asegúrese de que la posición de inicio es correcta antes de que inserte el quickfit conector.

DE_CAM-LOCK: Achten Sie bei der Montage des Cam-Locks auf die richtige Ausgangsposition, bevor Sie den Quickfit einsetzen.

IT_BLOCCAGGIO A CAMMA: Quando si monta il bloccaggio a camma, assicurarsi che la posizione iniziale sia corretta prima di inserire il montaggio rapido di collegamento

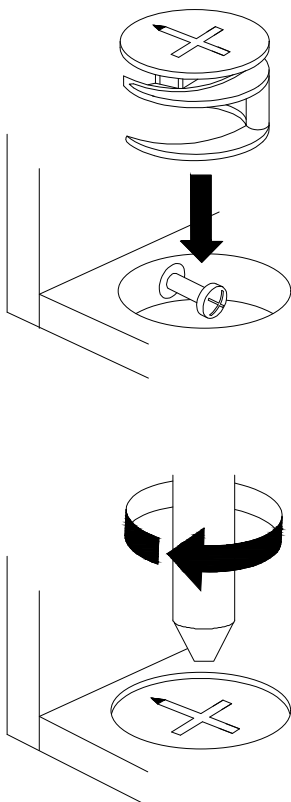

EN Quickfit head should be in the centre of the cam lock when the two panels are joined.

Cam lock should be inserted before quickfit.

FR_Lorsque les deux panneaux sont assemblés, la tête du raccord rapide doit reposer au centre de la serrure batteuse.

Il faut insérer la serrure batteuse avant le raccord rapide.

ES_El cabezal del quickfit debe estar en el centro del cierre de la cámara cuando se unan los dos paneles.

Se debe insertar el cierre de la cámara antes del quickfit.

DE_Der Quickfit-Kopf sollte sich in der Mitte des Cam-Locks befinden, wenn die beiden Platten zusammengefügt sind.

Der Cam-Lock sollte vor dem Quickfit eingesetzt werden.

IT_La testa del montaggio rapido deve trovarsi al centro del bloccaggio a camma quando i due pannelli sono uniti.

Il Bloccaggio a Camma deve essere inserito prima del montaggio rapido.

Il Bloccaggio a Camma deve essere inserito prima del montaggio rapido.

EN Turn cam lock clockwise to tighten.

FR Faites tourner la serrure batteuse dans le sens des aiguilles d'une montre pour la resserrer.

ES Gire el cierre de la cámara en sentido horario para apretarlo.

DE Drehen Sie den Cam-Lock im Uhrzeigersinn, um ihn festzuziehen.

IT Ruotare il bloccaggio a camma in senso orario per stringere.

EN It may be necessary to adjust the hinges so that the doors align. Use the instructions below as a guide.

FR Il est parfois necessaire d'ajuster les charnieres pour un meilleur alignement des portes. Servez-vous des instructions ci-dessous comme guide.

ES Puede que sea necesario ajustar los quicios de forma que se alineen las puertas. Use las instrucciones que aparecen debajo como guía.

DE_Moglicherweise müssen Sie die Scharniere so einstellen, dass die Türen ausgerichtet sind. Verwenden Sie die nachstehenden Anweisungen als Leitfaden.

IT_Potrebbe essere necessario regolare le cerniere in modo che le porte siano allineate. Per fare ciò attenersi alle istruzioni sottostanti.

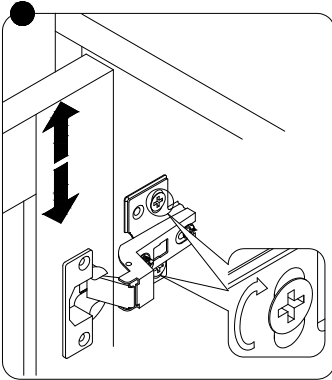

EN_To adjust the door vertically loosen the screw as shown and move up and down as needed.

FR_Si vous souhaitez regler la porte verticalement, desserrez la vis comme indique et deplacez la porte de haut en bas selon les besoins.

ES_Para ajustar la puerta verticalmente afloje el tornillo tal y como se muestra y muevalo hacia arriba o hacia abajo segun sea necesario.

DE_Um die Tür vertikal auszurichten, lösen Sie die Schraube wie abgebildet und bewegen Sie sie nach Bedarf nach oben oder nach unten.

IT_Per allineare la porta verticalmente allentare la vite come mostrato e spostarla in alto o in basso secondo necessita.

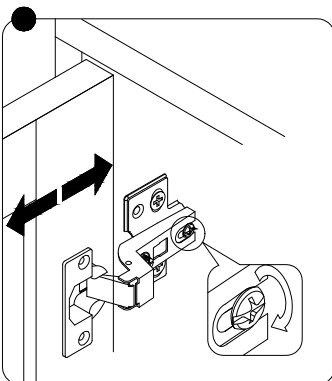

EN_To adjust the gap from the door to the main frame turn the screw clockwise or anti-clockwise as needed.

FR_Si vous souhaitez ajuster l'ecart entre la porte et le cadre principal, tournez la vis dans le sens des aiguilles d'une montre ou dans le sens inverse, si necessaire.

ES_Para ajustar el espacio desde la puerta al marco principal, gire el tornillo en sentido horario o antihorario, segun se necesite.

DE_Um den Abstand von der Tür zum Hauptrahmen auszurichten, drehen Sie die Schraube je nach Bedarf im oder gegen den Uhrzeigersinn.

IT_Per regolare lo spazio tra la porta e il telaio principale, avvitare o svitare la vite secondo necessita.

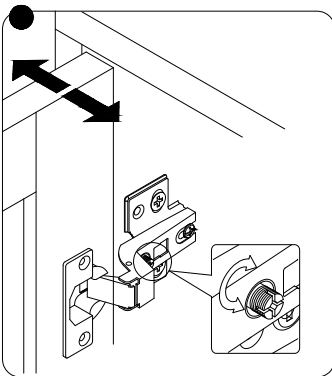

EN To adjust the door laterally adjust the screw as shown by turning clockwise or anti-clockwise.

FR_Si vous souhaitez ajuster la porte lateralement, ajustez la vis comme indique en tournant dans le sens des aiguilles d'une montre ou dans le sens inverse des aiguilles d'une montre.

ES_Para ajustar la puerta lateralmente ajuste el tornillo tal y como se muestra girandolo en sentido horario y antihorario.

DE_Um die Tür seitlich auszurichten, stellen Sie bitte die Schraube wie abgebildet durch Drehen im oder gegen den Uhrzeigersinn ein.

IT_Per allineare la porta lateralmente regolare la vite come mostrato, avvitandola o svitandola.

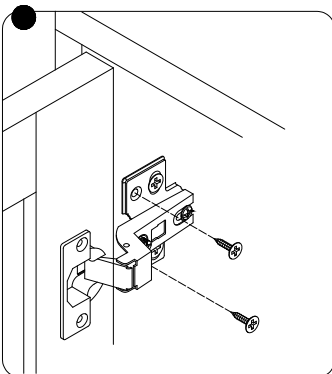

EN Please fix other screws











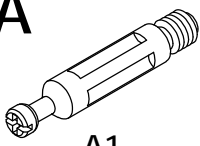

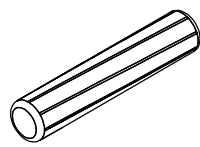
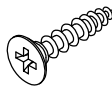
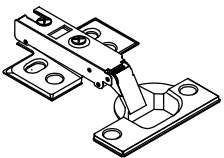
FR Merci de serrer les autres vis.

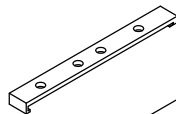
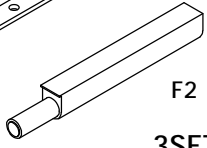
ES Fije los demas tornillos

DE Befestigen Sie bitte die anderen Schrauben

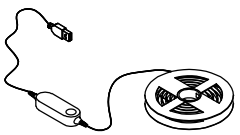
IT Fissare le altre viti

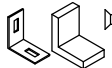
Hardware N625P402475

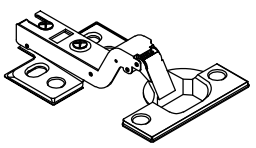
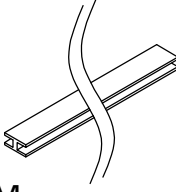
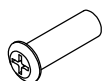
<p>A</p>  <p>A1</p>  <p>A2</p> <p>24SETS</p>	<p>B</p>  <p>8 x 40MM</p> <p>24PCS</p>	<p>C</p>  <p>3.5 x 14MM</p> <p>48PCS</p>	<p>D</p>  <p>4PCS</p>
<p>E</p>  <p>M6 x 15MM</p> <p>10PCS</p>	<p>F</p>  <p>F1</p>  <p>F2</p> <p>3SETS</p>	<p>G</p>  <p>10PCS</p>	<p>H</p>  <p>18PCS</p>
<p>J</p>  <p>3.5 x 12MM</p> <p>16PCS</p>	<p>K</p>  <p>1SET</p>	<p>L</p>  <p>4PCS</p>	<p>M</p>  <p>30PCS</p>
<p>N</p>    <p>2SETS</p>	<p>P</p>  <p>2PCS</p>	<p>Q</p>  <p>648MM</p> <p>1PC</p>	<p>R</p>  <p>M6 x 20MM</p> <p>4PCS</p>

1

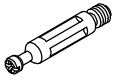
A1

8PCS

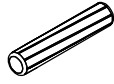
B

8 x 40MM

C

8PCS 3.5 x 14MM

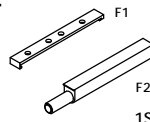
F

1SET

G

4PCS

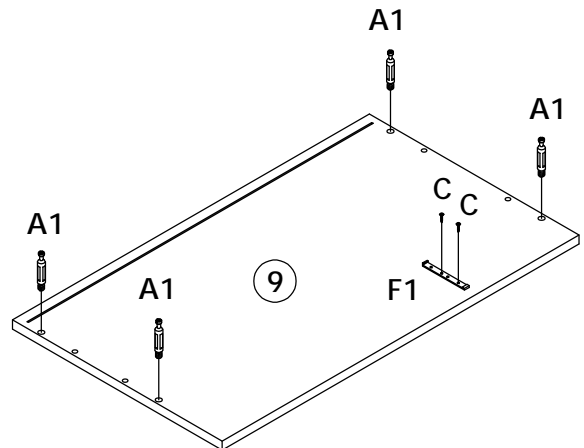
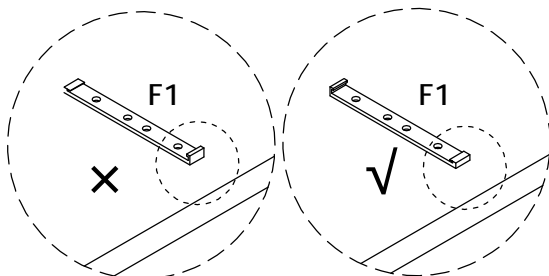
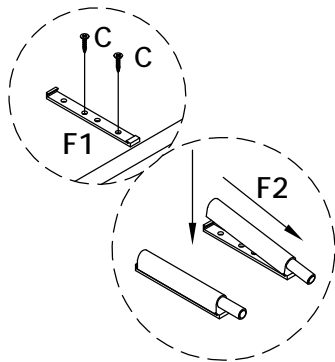
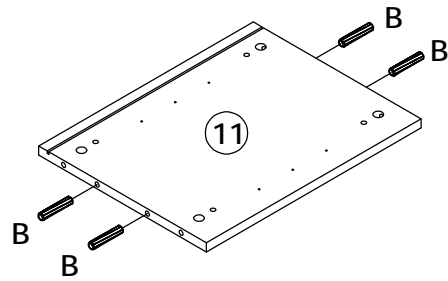
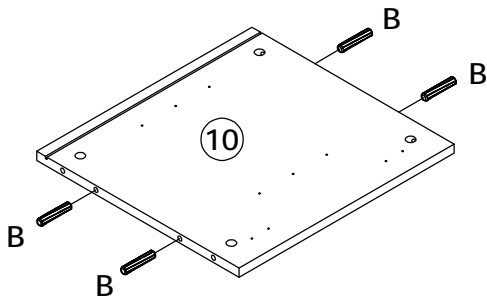
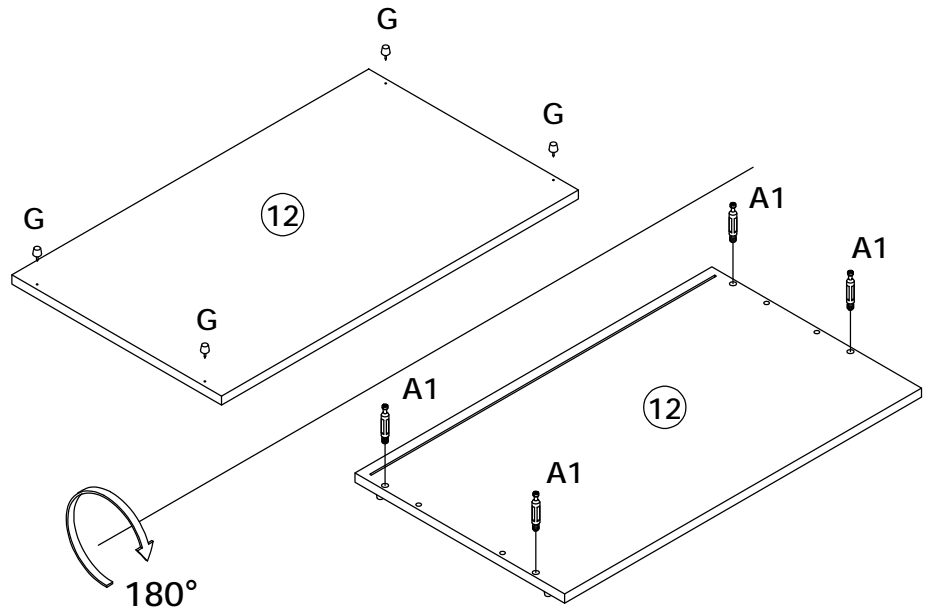
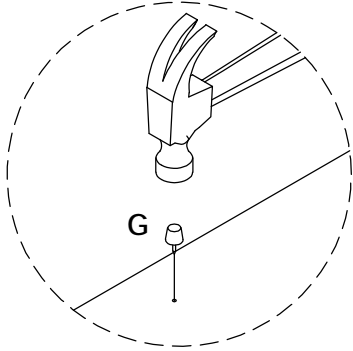

2

A2



4PCS

Q

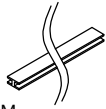

648MM

1PC

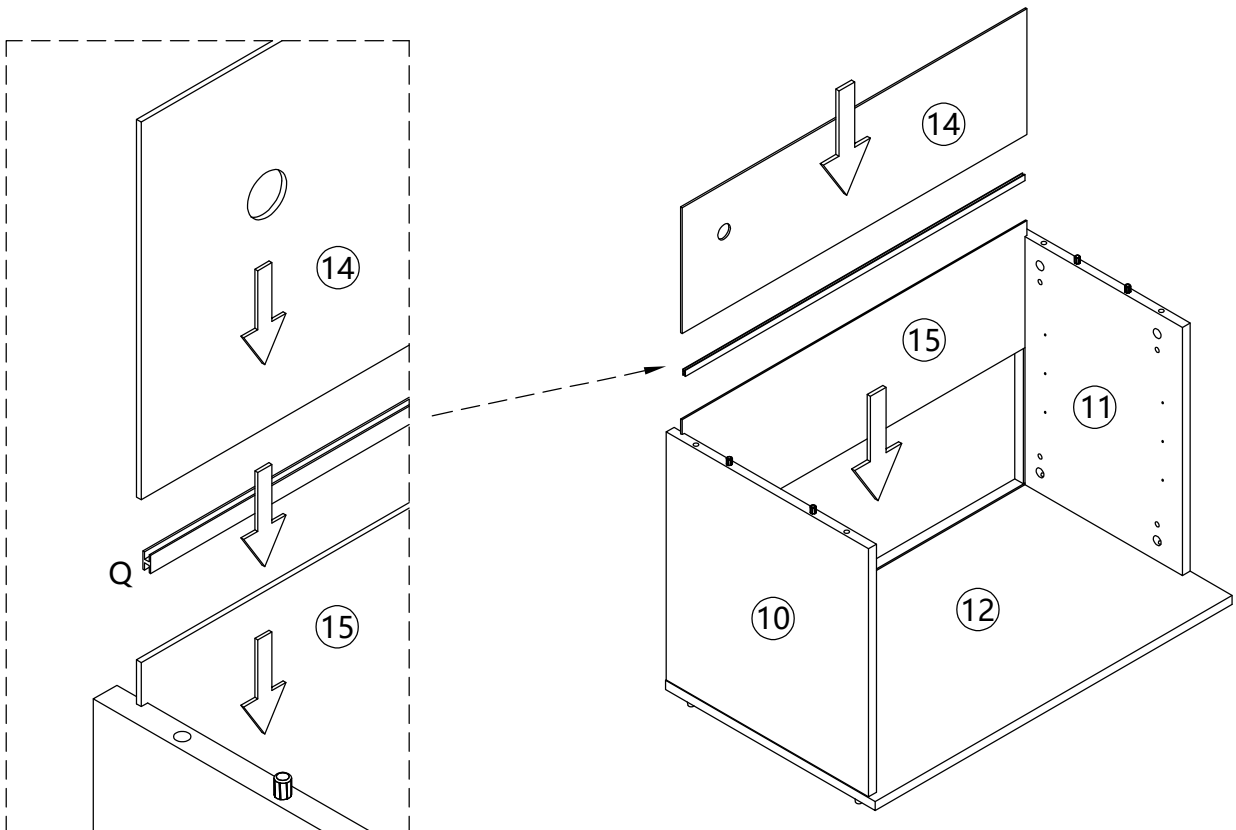
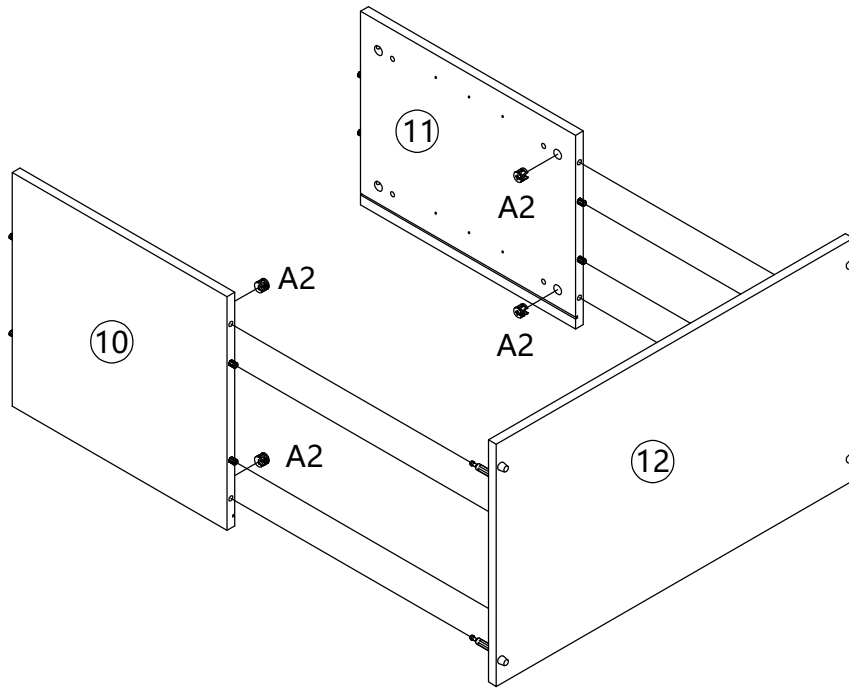

3

A2



4PCS

K



1SET

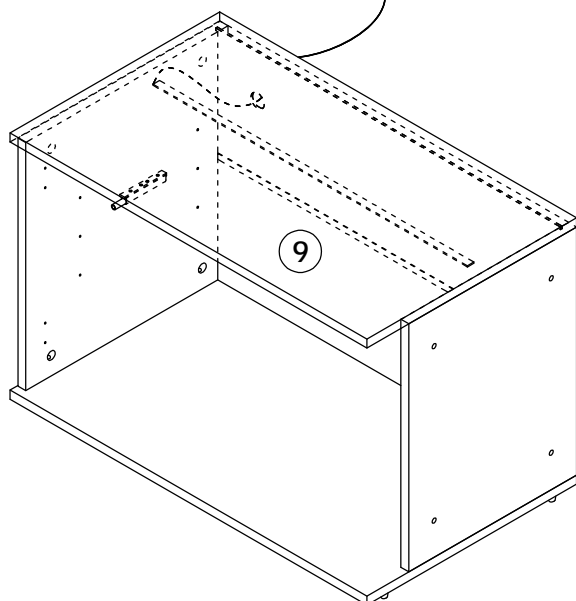
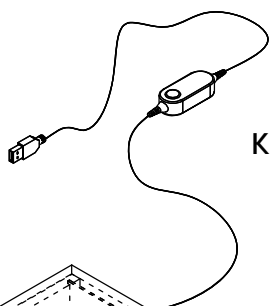
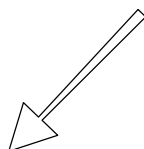
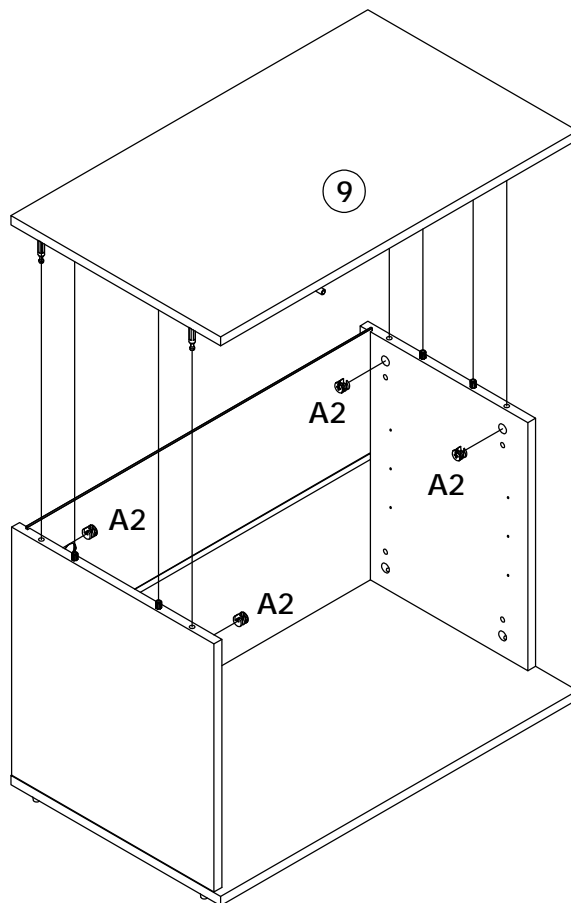

EN:Scan to download App control the Led light.
DE:Scannen, um die App zum Steuern des LED-Lichts herunterzuladen
FR:Scanner pour télécharger App contrôler la lumière Led.
ES:Analice para descargar la aplicación control de la luz Led.
IT:Scansiona per scaricare l ' applicazione controlla la luce Led.

4

A1

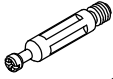

10PCS

C



3.5 x 14MM

4PCS

F

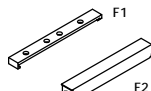

2SETS

G



6PCS

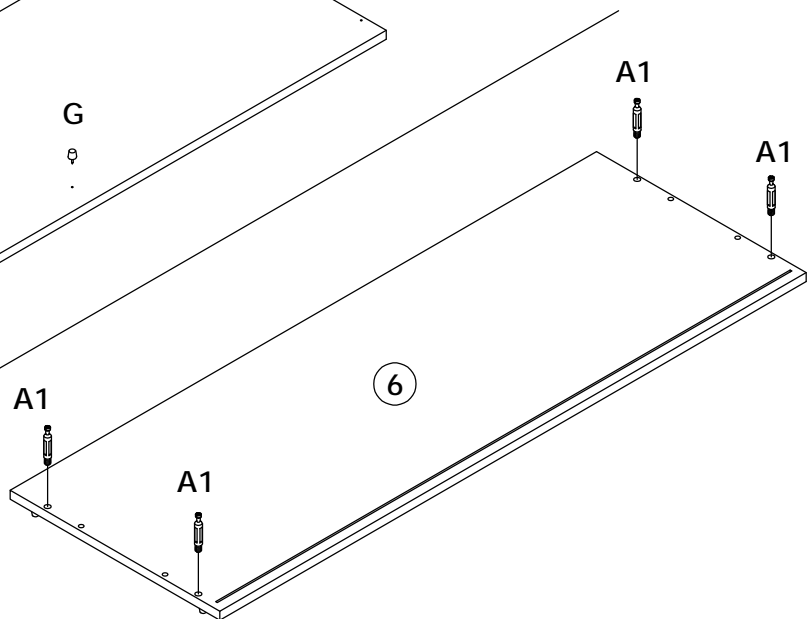
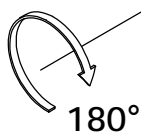
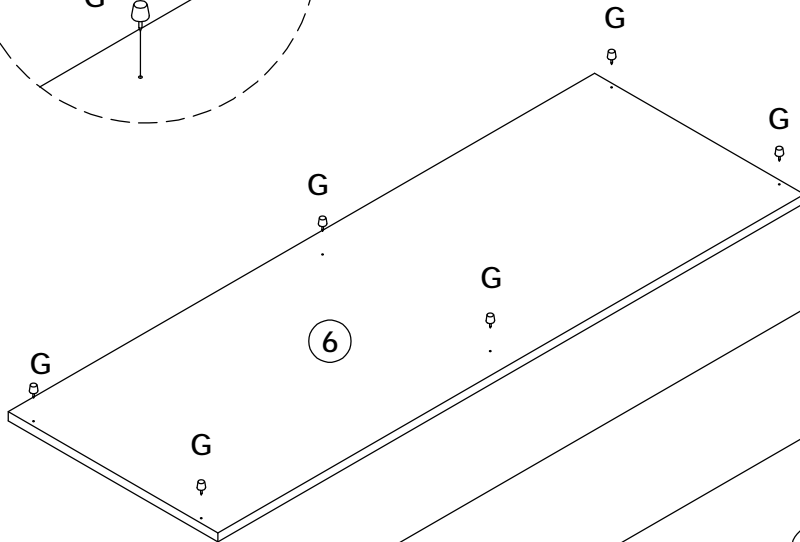
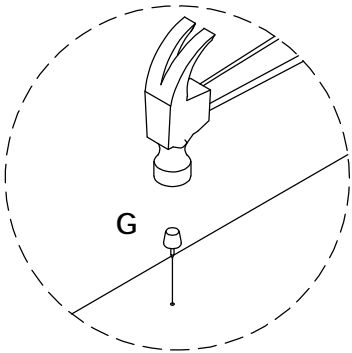
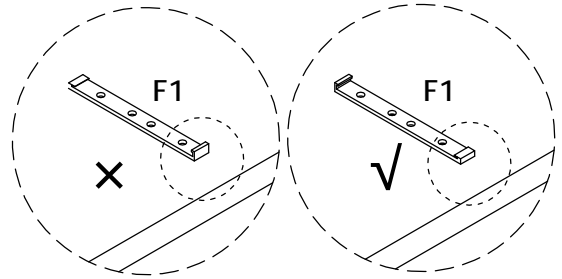
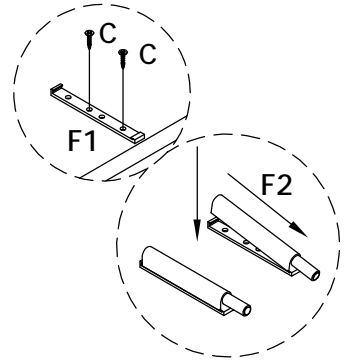
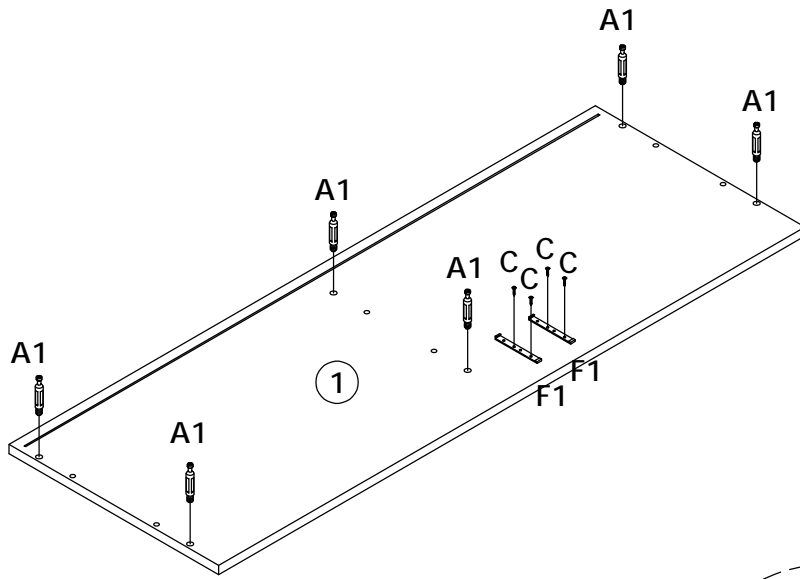

5

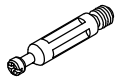
A1

6PCS

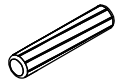
B

8 x 40MM

16PCS

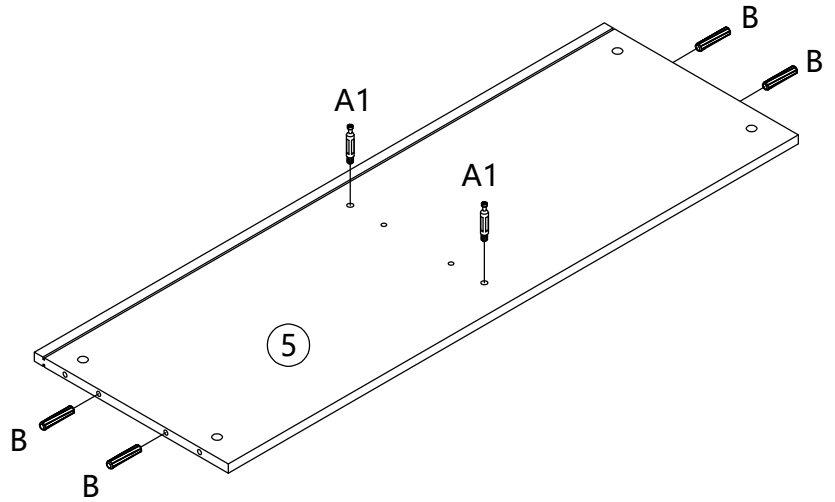
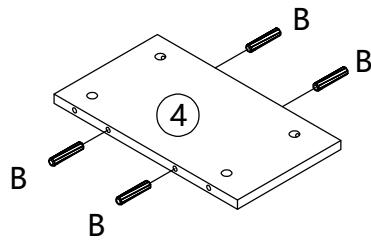
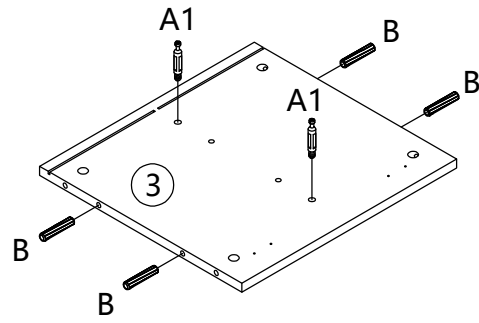
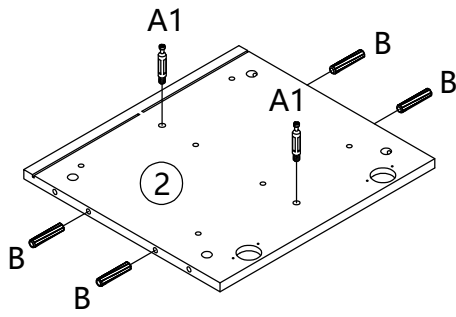

6

A2

4PCS

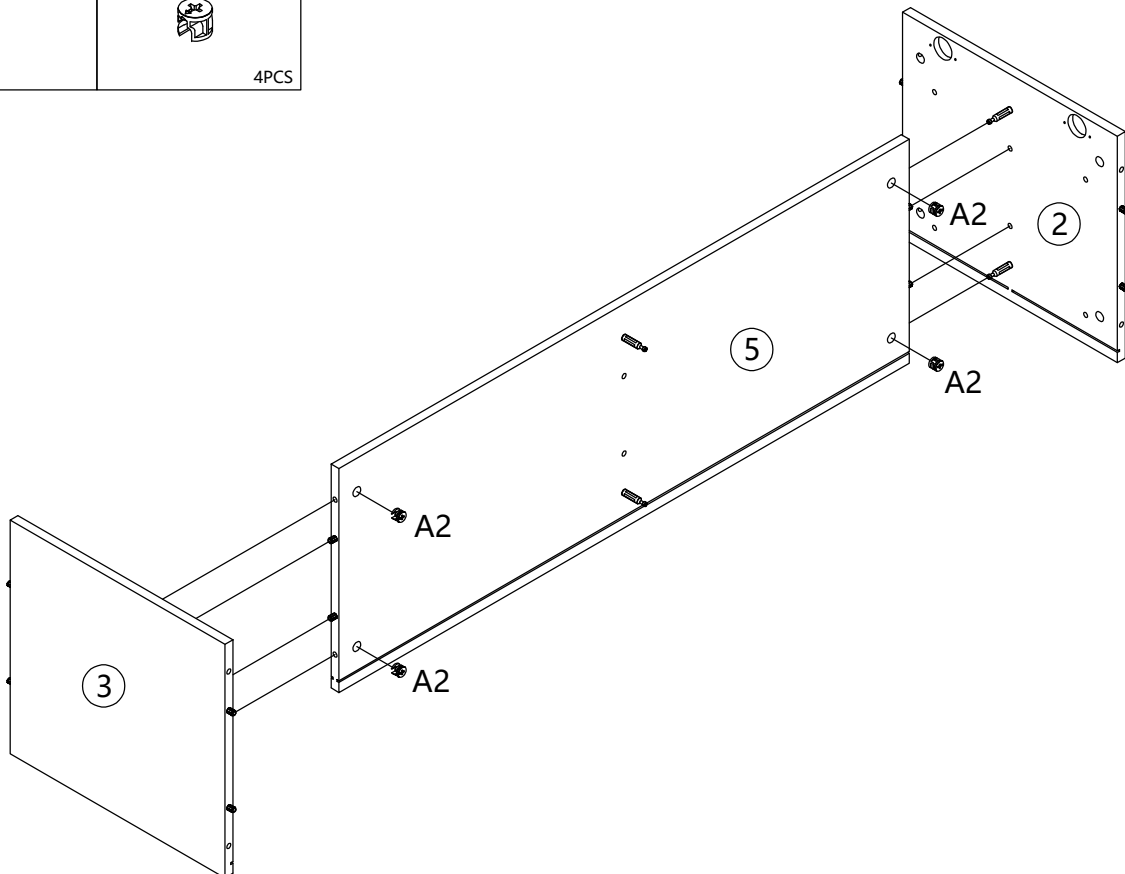

7

A2



4PCS

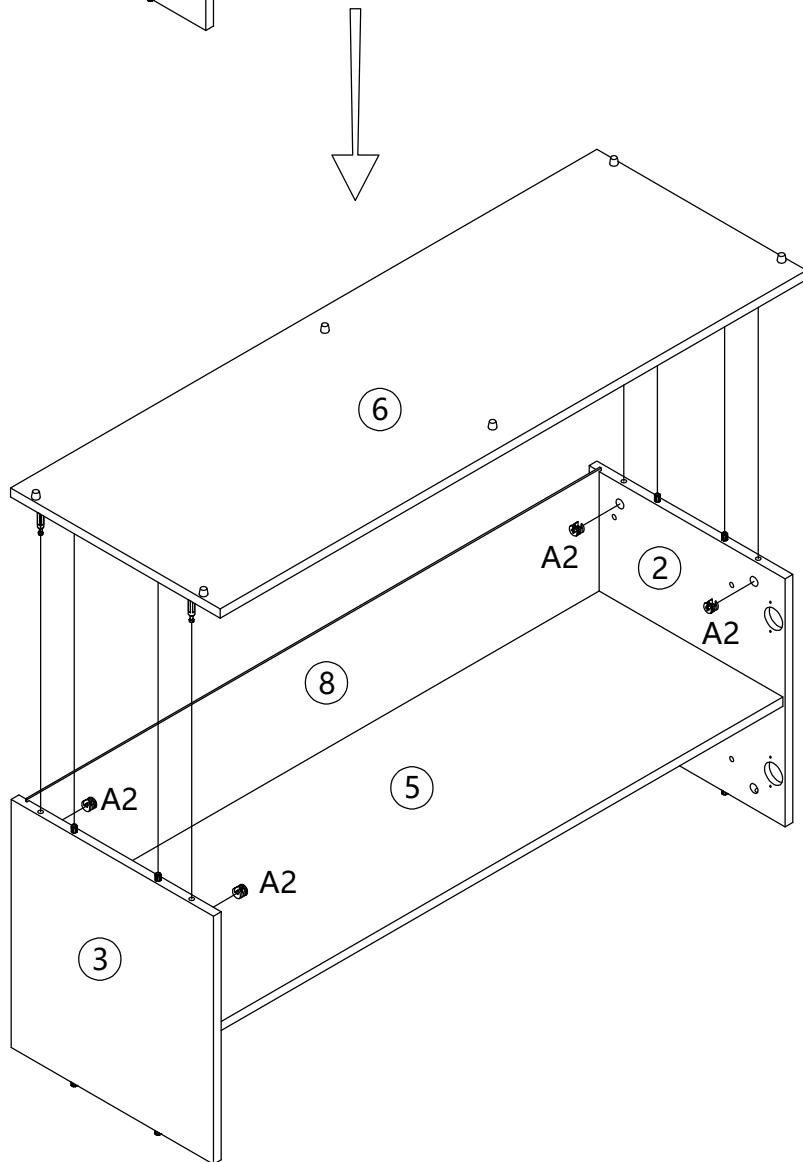
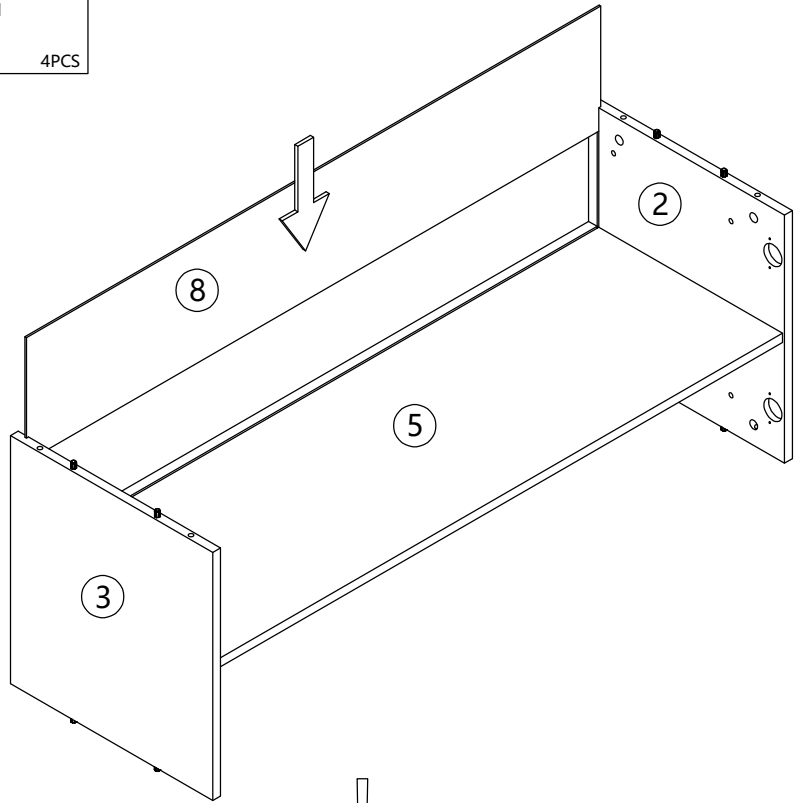

8

A2



8PCS

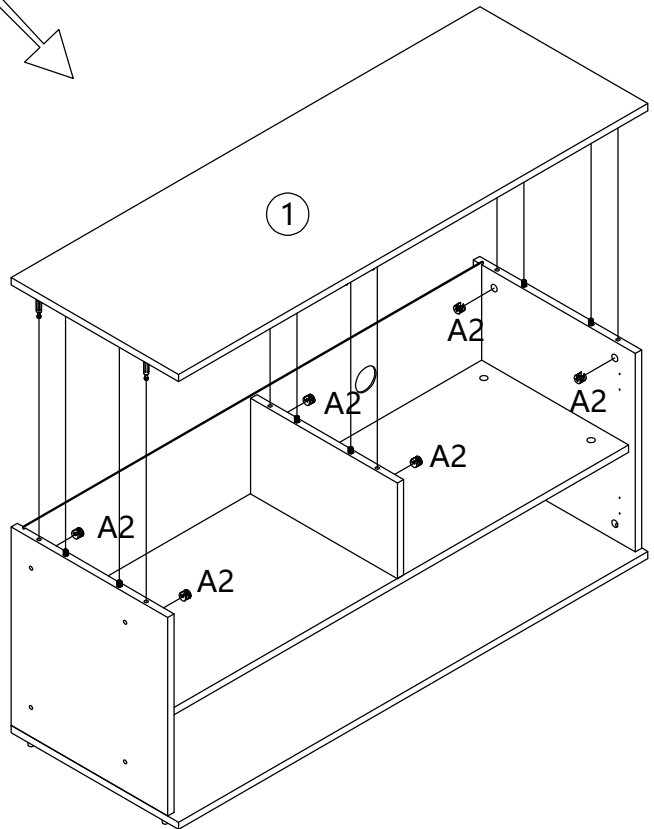
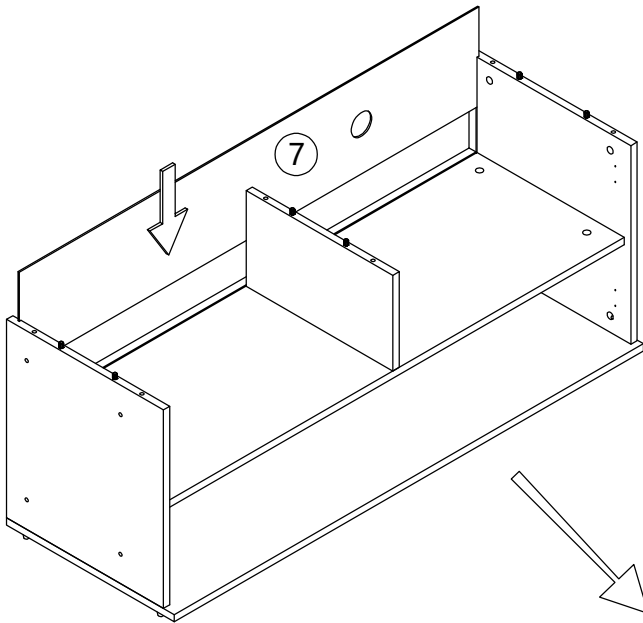
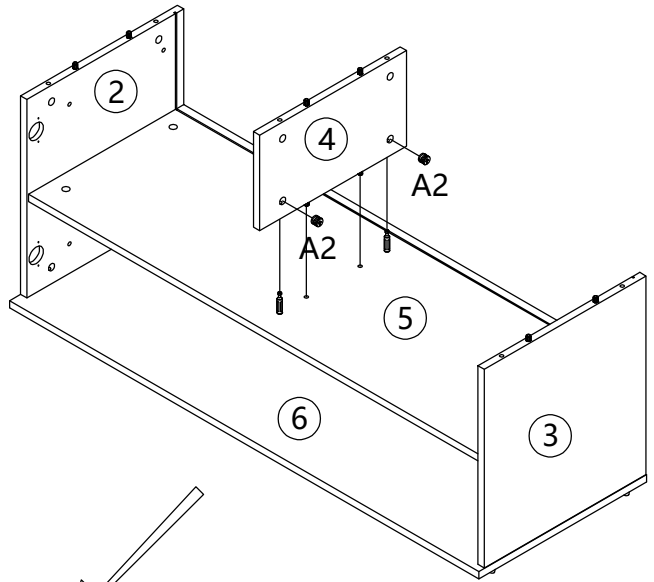

9

E

M6 x 20MM

4PCS

R

M6 x 20MM

4PCS

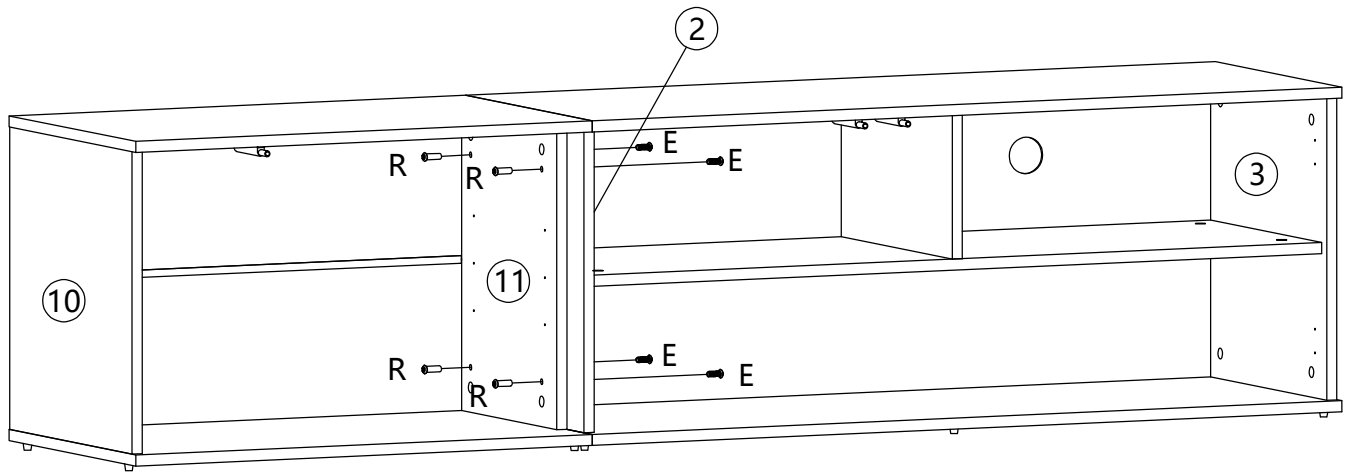

10

C

3.5 x 14MM

18PCS

H

18PCS

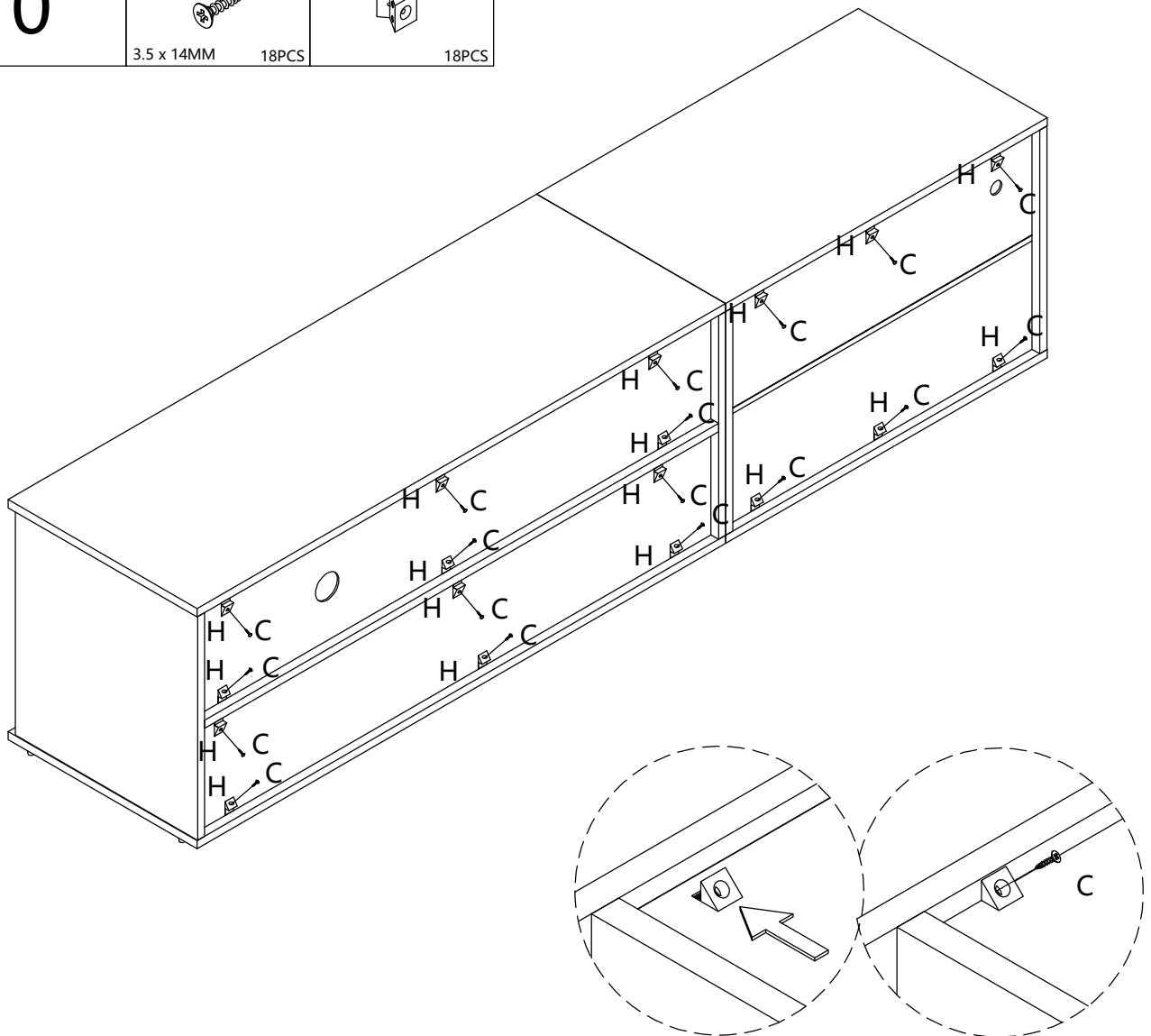

11

C



3.5 x 14MM

4PCS

L



4PCS

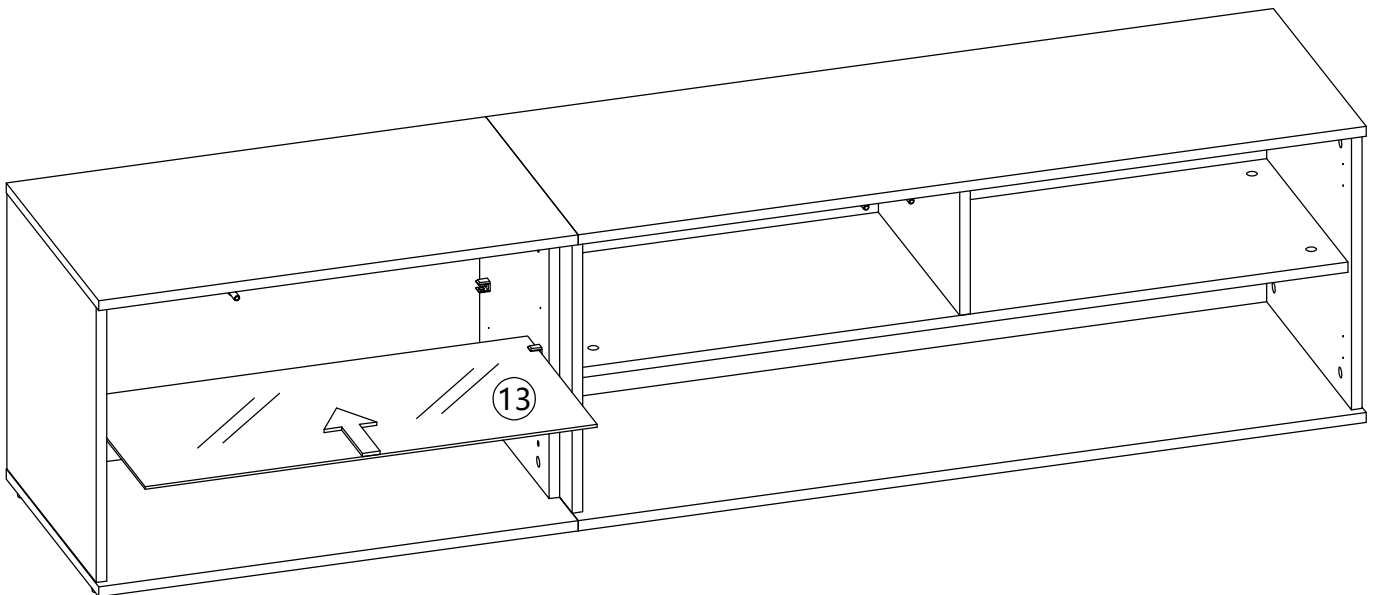
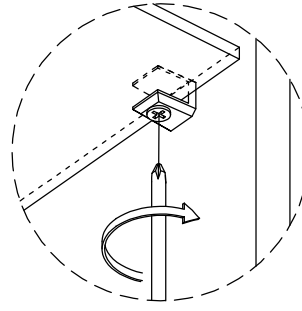
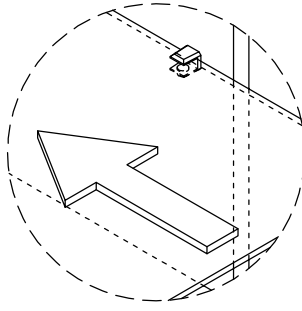
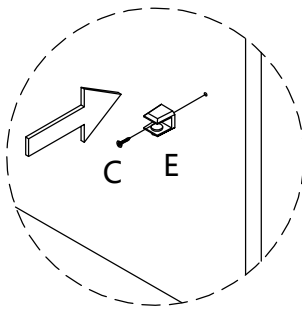
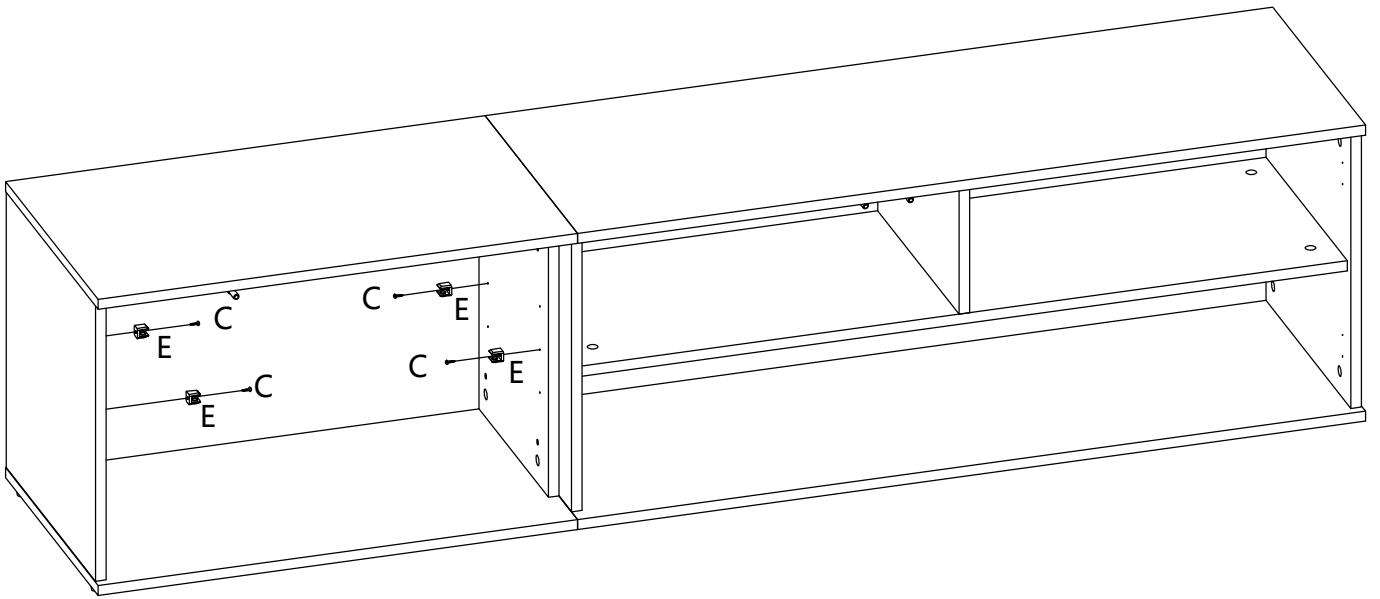

12

C

3.5 x 14MM

4PCS

J

3.5 x 12MM

8PCS

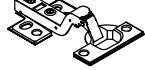
P

2PCS

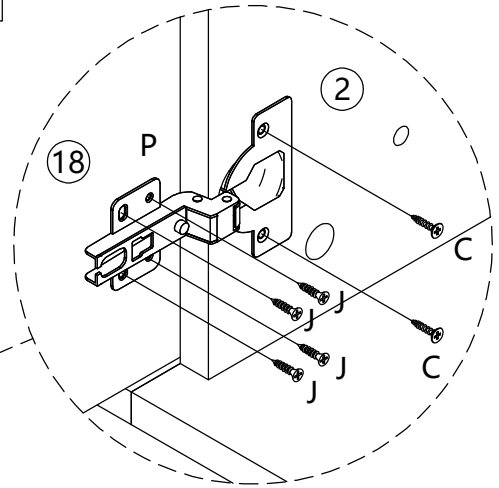
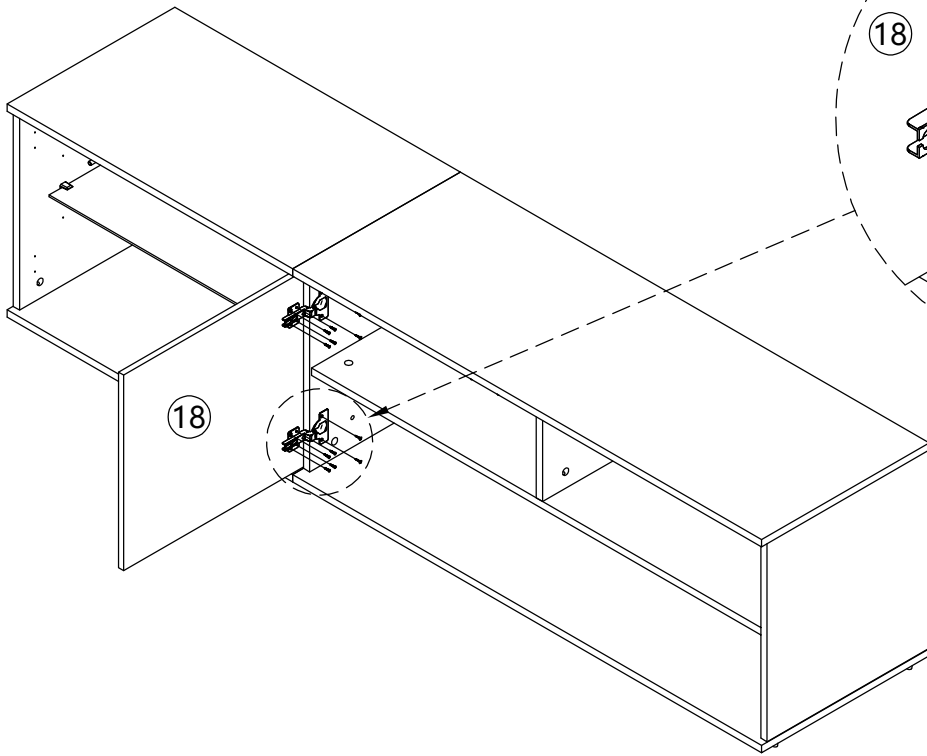

13

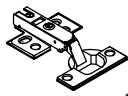
D

4PCS

E

M6 x 20MM

J

3.5 x 12MM

8PCS

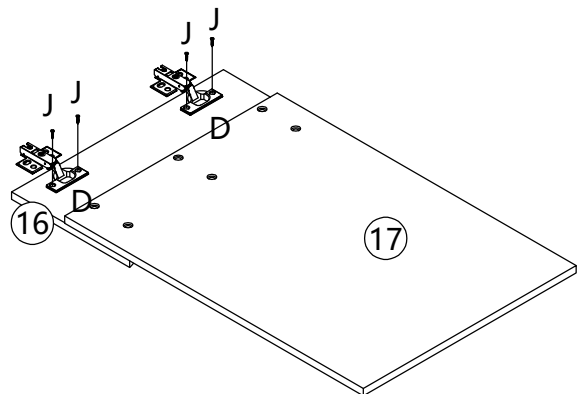
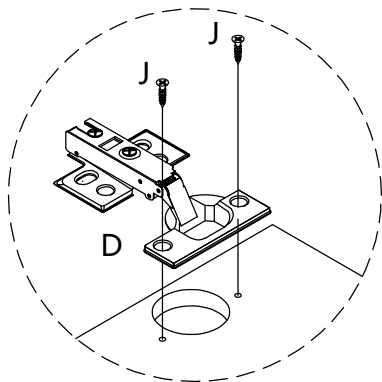
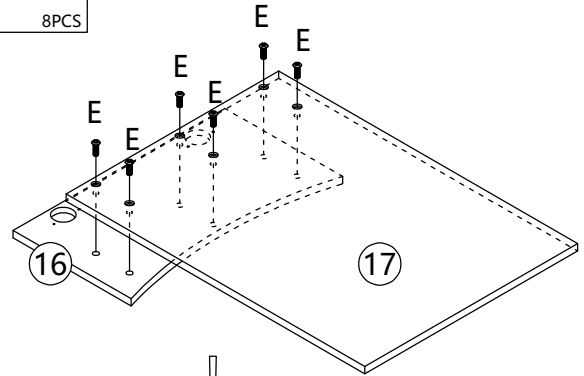
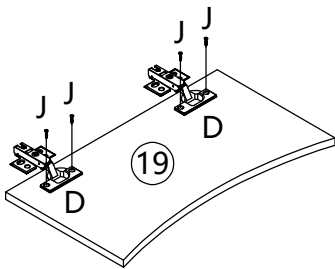

14

C

3.5 x 14MM



16PCS

M



30PCS

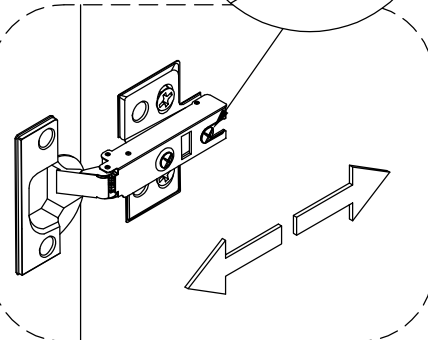
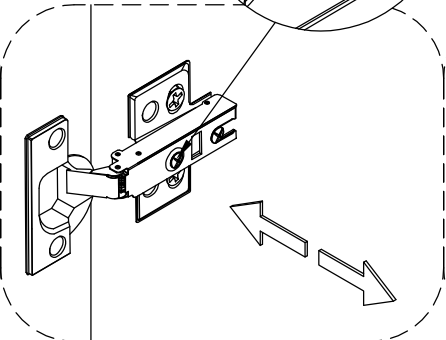
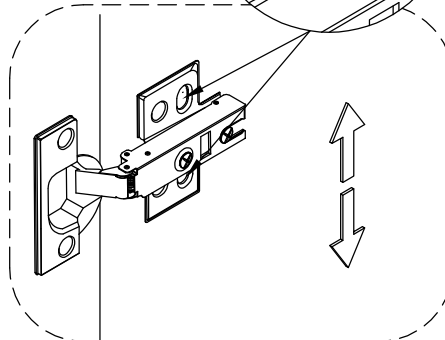
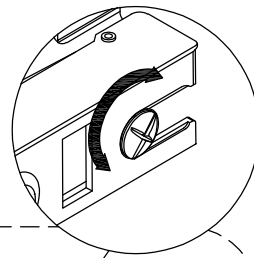
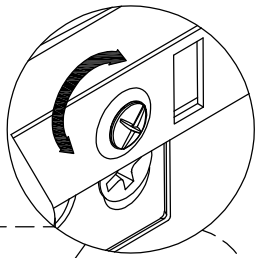
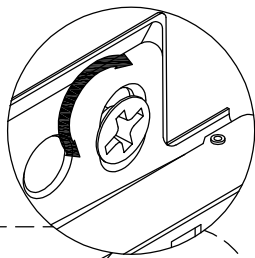
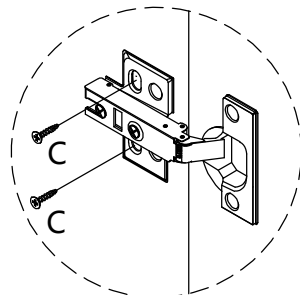
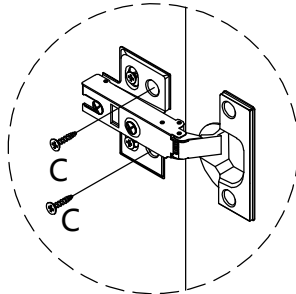
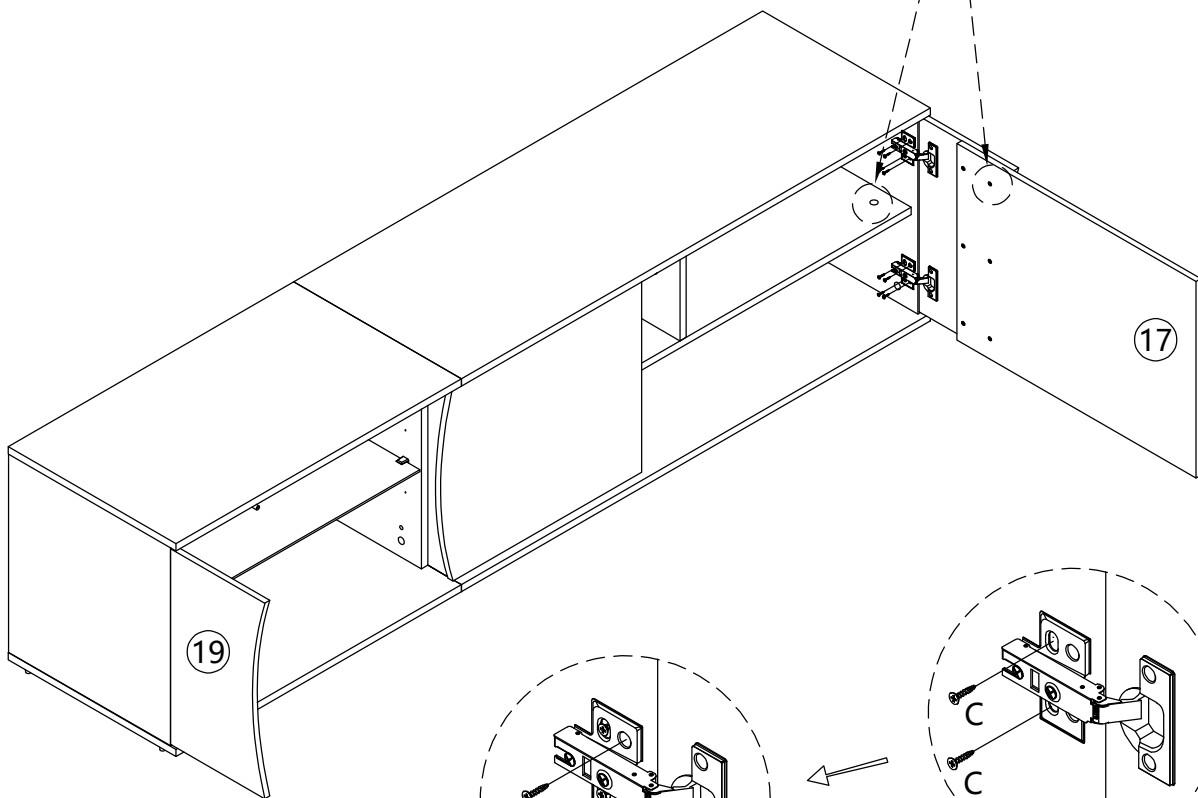
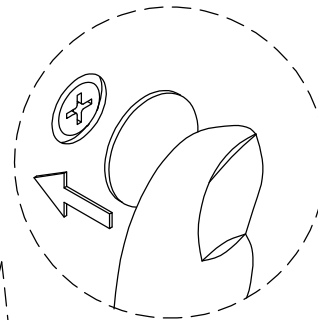
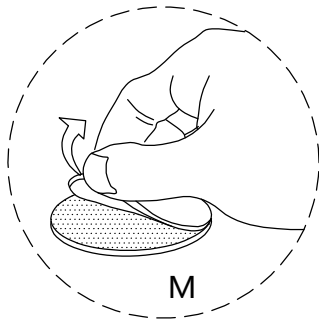

15

N



2SETS

1.

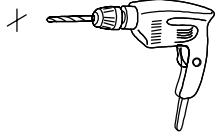

2.

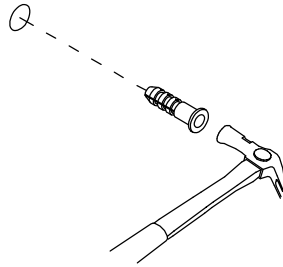

3.

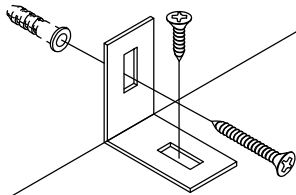

4.

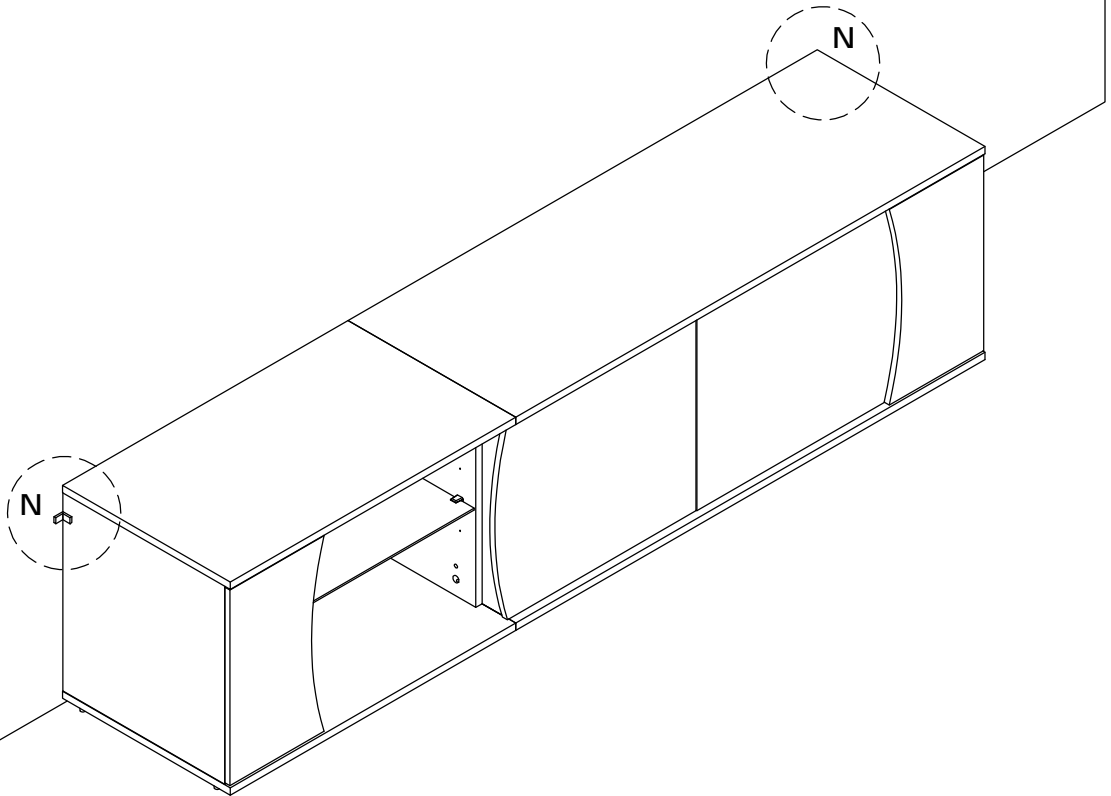
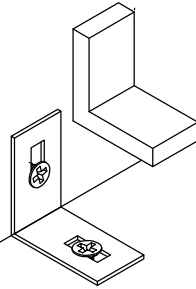

EN:PLEASE NOTE:Part number 17.19. is covered with atight plastic protectivefilm.If there are scratches on the product after disassembly,please don't worry,it's not product damage.Please slowly tear off the protective plastic film on the surface along the edge.After peeling off,the product becomes smooth and clean.

DE:Bitte beachten Sie:TeilNr.17.19. sind mit einerdichten Kunststoffschutzfolie abgedeckt. Wenn das Produkt nach der Demontage K ratzer aufweist,machen Sie sich bittekeine Sorgen,es handelt sich nicht um einen Produktschaden.Bitte ziehen Sie die schützende Kunststofffolie auf der Oberfläche entlang derKante langsam ab.Nach dem Abziehen wird das Produkt glatt und sauber.

FR:Veillez noter : piece n°17.19. sont recouverts d'un film protecteur en plastique dense. Si le produit presente des rayures apres le demontage, ne vous inquietez pas.Il ne s'agit pas d' un dommage au produit. V euillez retirer lentement le film plastique protecteur sur la surface le long du bord. Apres le decollage, le produit sera lisse et propre.

IT:Nota: parten. 17.19. sono ricoperti da una densa pellicola protettiva in plastica. Se il prodotto presenta graffi dopo lo smontaggio, non preoccuparti Non si tratta di un danno al prodotto. Rimuovere lentamente la pellicola di plastica protettiva sulla superficie lungo il bordo. Dopo averla staccata, il prodotto sara liscio e pulito.

ES:Tenga en cuenta: Parte No.17.19. Estan cubiertos con una pelicula protectora de plastico densa. Si el producto tiene rayones despues del desmontaje, no se preocupe. Esto no es un dano al producto. Retire lentamente la pelicula protectora de plastico de la superficie a lo largo del borde. Despues de despegarlo, el producto quedara liso y limpio.

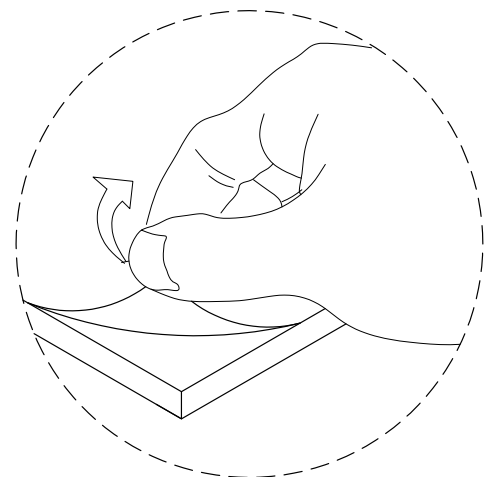
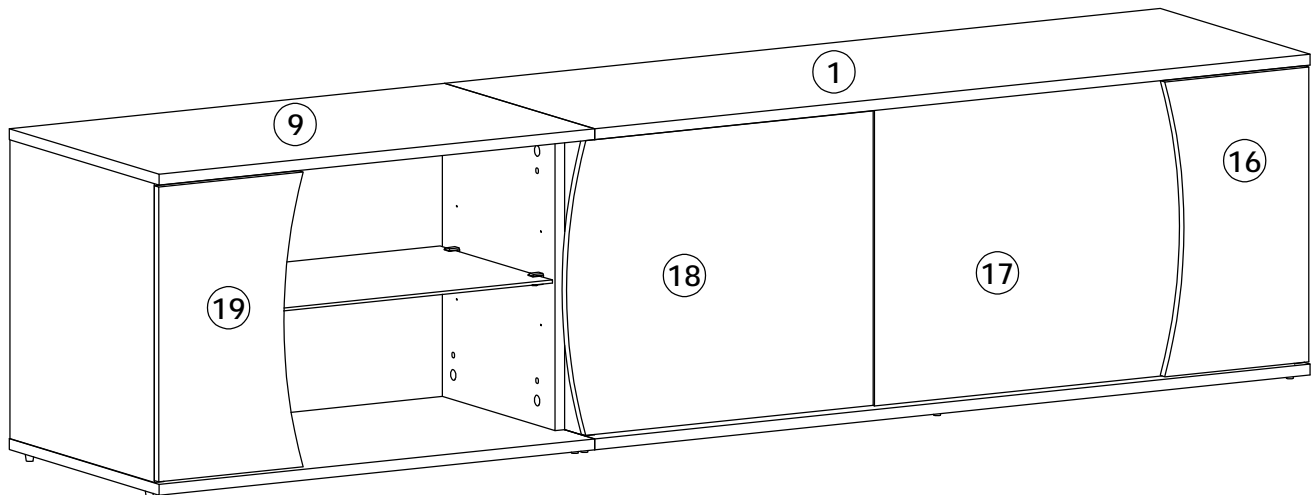

Verification of Compliance

Verification No.: TMC210319126-E

Name and address of Applicant: **Shenzhen CWG Technology Co., Ltd**
5 / F, No.264 Baoshi East Road, Shiyan street, Bao'an District, Shenzhen,China 518108

Name and address of Manufacturer: **Shenzhen CWG Technology Co., Ltd**
5 / F, No.264 Baoshi East Road, Shiyan street, Bao'an District, Shenzhen,China 518108

Product name: **LED Strip**

Rated: DC12V

Product model(s): CWG-5050RGB-60D-12V , additional models reference attachment

Product trademark: 创唯光

This verification confirms that the product meets the requirements of the following standard.
The conformity was demonstrated based on following standard(s) listed by European Commission as harmonized with EMC Directive 2014/30/EU.

EN IEC 55015:2019+A11:2020
IEC 61547:2020

The verification has been carried out in accordance with individual rules and conditions agreed with the applicant. Evaluation has been carried out in accordance with:

Test report(s) No.: TMC210319126-E

Test conducted by: TMC Testing Services (Shenzhen) Co., Ltd.

Verification issue date: March 26, 2021

Notes:

This verification refers to the above mentioned product and its conformity in regards of above mentioned standard(s) was proven on test sample.

This verification does not imply meeting all essential requirements, assessment of the series-production or any other restricted Notified Bodies conformity assessment procedure appropriate for the product.

This verification holder shall use this verification in connection to verification of conformity and technical data relevant for the product the verification was issued.

TMC Testing Services (Shenzhen) Co., Ltd.

t:86-755-86642861 cert@tmc-lab.com www.tmc-lab.com

1st Floor, Block A1, Zone A, Xinshidai Gongrong Industrial Park, No. 2, Shihuan Road, Shiyan Street, Baoan District, Shenzhen, China



Verification of Compliance

CWG-5050RGB-30D-12V, CWG-5050RGB-18D-12V, CWG-5050RGB-60D-24V,
CWG-5050RGB-60D-5V, CWG-5050RGB-30D-5V, CWG-5050RGB-18D-5V,
CWG-5050-60D-12V, CWG-5050-30D-12V, CWG-5050-60D-24V,
CWG-HC5050RGB-60D-12V, CWG-HC5050RGB-30D-12V,
CWG-HC5050RGB-60D-24V, CWG-HC5050-60D-12V, CWG-HC5050-30D-12V,
CWG-HC5050-60D-24V, CWG-HC5050RGB-30D-5V, CWG-HC5050RGB-60D-5V,
CWG-HC5050RGB-144D-5V, CWG-2835-60D-12V, CWG-2835-120D-12V,
CWG-2835-60D-24V, CWG-2835-120D-24V, CWG-2835-60D-5V, CWG-2835-120D-5V

Note:

This attachment only valid with Verification No.: TMC210319126-E