

Montageanleitung | Instructions de montage Assembly Instructions | Instrucciones de montaje

SKU NUMBER: N616P425629/N616P425630
N616P425631

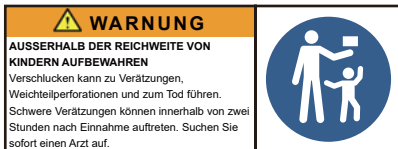
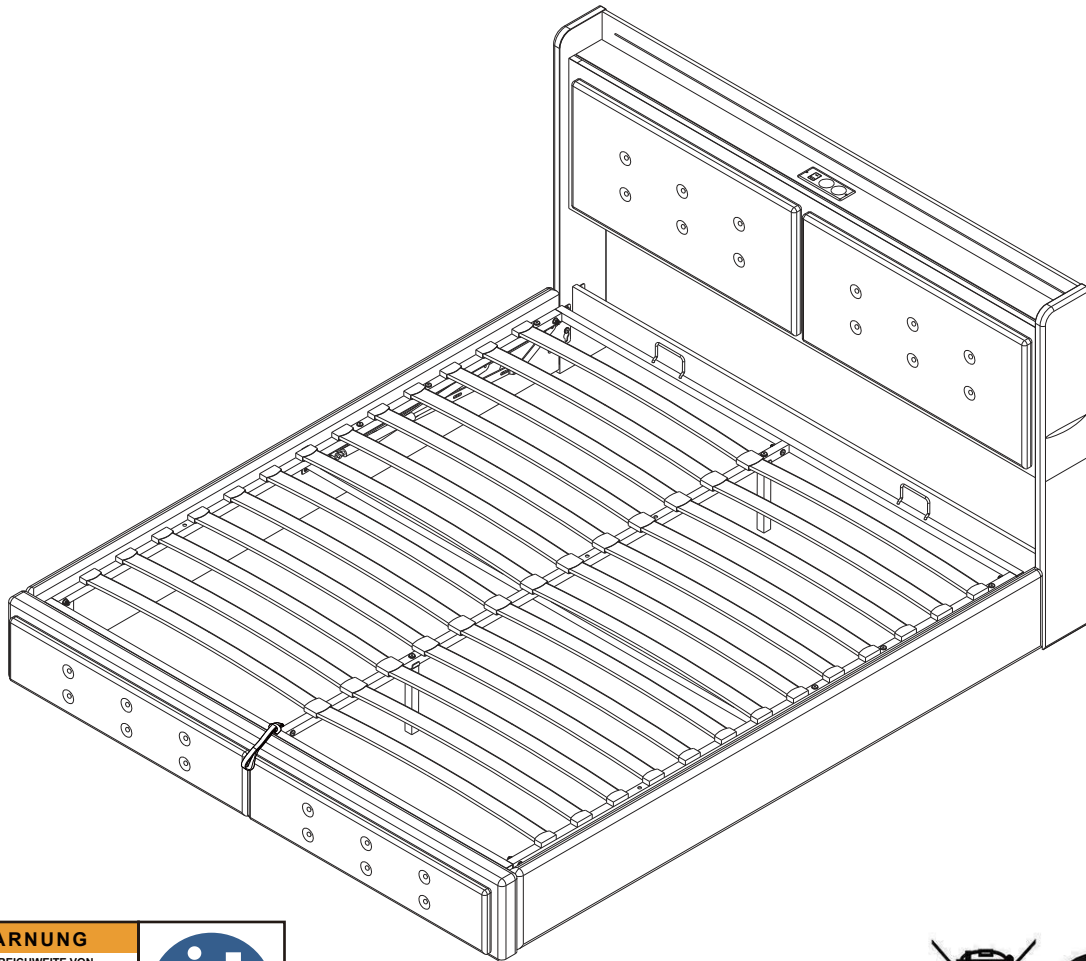

GB This set comes in 3 boxes. If you do not receive a full set of 3 boxes, please contact our customer service.

DE Dieses Set wird in 3 Schachteln geliefert. Wenn Sie nicht ein komplettes Set von 3 Boxen erhalten, kontaktieren Sie bitte unseren Kundenservice.

FR Ce set est livré en 3 boîtes. Si vous ne recevez pas un jeu complet de 3 boîtes, veuillez contacter notre service clientèle.

English

IMPORTANT FOR GAS LIFT BEDS&MAINTAINCE

- Please place the mattress on top of the bed frame.
- Please do not pull on the strap handles.
- Please press heavily to release the compressed gas.
- Periodically check all screw & fixings to ensure they are secure.
- When moving your product, carefully lift into place.
- Wipe clean with a slightly damp cloth- please do not use abrasive chemicals or bleach.
- Do NOT allow children to operate the lift mechanism.
- Do NOT allow children near the lift base when operating the mechanism.
- Do NOT stand inside the bed or the internal storage base.
- Do NOT overload the internal storage base.
- DO NOT jump on the product or any of its parts.

Deutsch

WICHTIG FÜR GASLIFT-BETTEN&WARTUNG

- Bitte legen Sie die Matratze oben auf den Bettrahmen.
- Bitte ziehen Sie nicht an den Gurtgriffen.
- Bitte drücken Sie kräftig, um das komprimierte Gas freizusetzen.
- Überprüfen Sie regelmäßig alle Schrauben und Befestigungen, um sicherzustellen, dass sie sicher sind.
- Wenn Sie Ihr Produkt bewegen, heben Sie es vorsichtig an seinen Platz.
- Mit einem leicht feuchten Tuch abwischen - bitte keine scheuernden Chemikalien oder Bleichmittel verwenden.
- Erlauben Sie Kindern NICHT, den Hebemechanismus zu bedienen.
- Lassen Sie Kinder NICHT in die Nähe des Liftsockels, wenn Sie den Mechanismus bedienen.
- Stellen Sie sich NICHT in das Bett oder in die Innenablage.
- Überlasten Sie den internen Liftsockel NICHT.
- Springen Sie NICHT auf das Produkt oder eines seiner Teile.

Français

IMPORTANT POUR LES LITS À RELEVAGE DE GAZ&MAINTENANCE

- Veuillez placer le matelas sur le dessus du cadre de lit.
- Ne tirez pas sur les poignées de la sangle.
- Appuyez fortement pour libérer le gaz comprimé.
- Vérifiez régulièrement que toutes les vis et fixations sont bien en place.
- Lorsque vous déplacez votre produit, soulevez-le avec précaution pour le mettre en place.
- Nettoyez avec un chiffon légèrement humide - n'utilisez pas de produits chimiques abrasifs ou d'eau de Javel.
- Ne laissez pas les enfants utiliser le mécanisme de levage.
- Ne laissez pas les enfants s'approcher de la base de levage lorsqu'ils actionnent le mécanisme.
- Ne vous tenez PAS à l'intérieur du lit ou de la base de stockage interne.
- Ne surchargez pas la base de stockage interne.
- Ne pas sauter sur le produit ou l'une de ses parties.

Italiano

IMPORTANTE PER I LETTI CON SOLLEVAMENTO A GAS E LA MANUTENZIONE

- Posizionare il materasso sopra la struttura del letto.
- Non tirare le maniglie della cinghia.
- Premere con forza per rilasciare il gas compresso.
- Controllare periodicamente tutte le viti e i fissaggi per assicurarsi che siano saldi.
- Quando si sposta il prodotto, sollevarlo con cautela.
- Pulire con un panno leggermente umido, senza usare prodotti chimici abrasivi o candeggina.
- NON permettere ai bambini di azionare il meccanismo di sollevamento.
- NON permettere ai bambini di avvicinarsi alla base di sollevamento quando si aziona il meccanismo.
- NON sostare all'interno del letto o della base di contenimento interna.
- NON sovraccaricare la base di contenimento interna.
- NON saltare sul prodotto o sulle sue parti.

Español

IMPORTANTE PARA LAS CAMAS ELEVADORAS DE GAS&MANTENIMIENTO

- Coloque el colchón sobre el somier.
- No tire de las asas de la correa.
- Presione con fuerza para liberar el gas comprimido.
- Compruebe periódicamente que todos los tornillos y fijaciones estén bien sujetos.
- Al mover el producto, levántelo con cuidado para colocarlo en su sitio.
- Limpie con un paño ligeramente humedecido; no utilice productos químicos abrasivos ni lejía.
- NO permita que los niños accionen el mecanismo de elevación.
- NO permita que los niños se acerquen a la base elevadora cuando accionen el mecanismo.
- NO se ponga de pie dentro de la cama o de la base de almacenamiento interna.
- NO sobrecargue el somier.
- NO salte sobre el producto ni sobre ninguna de sus piezas.

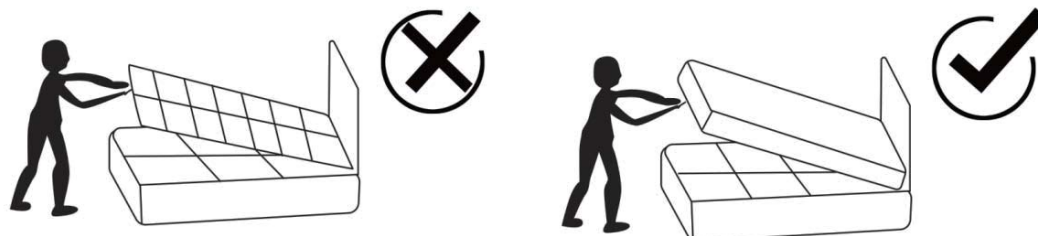

Stückliste

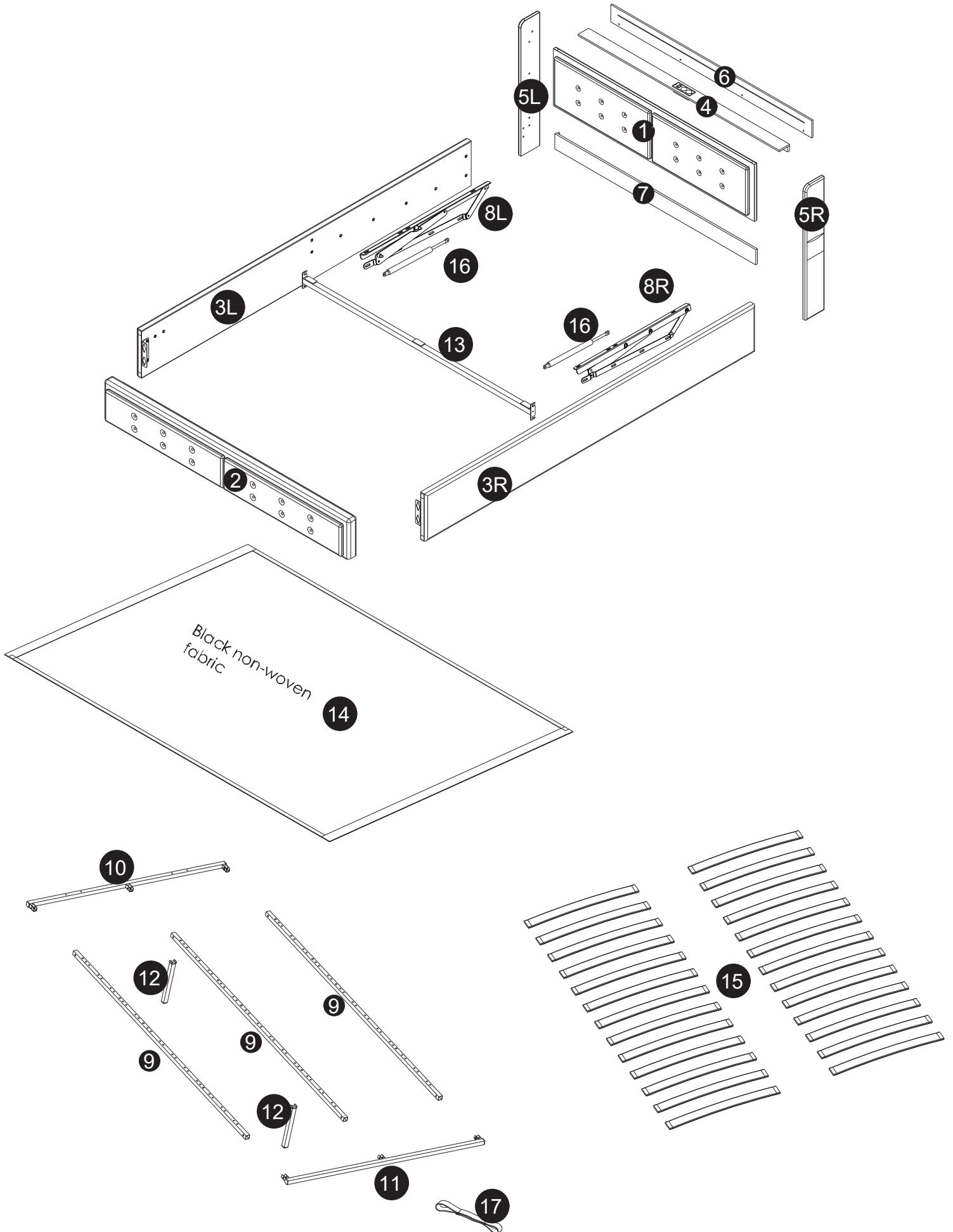

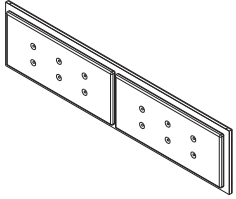

N616P425629

1		X1
---	---	----

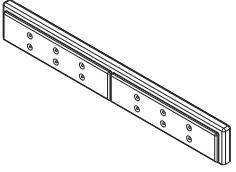
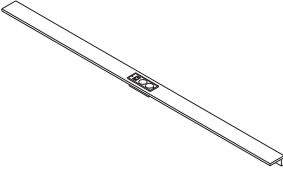
N616P425630

2		X1
4		X1

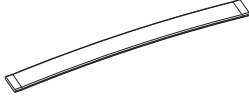

5L		X1
5R		X1

15		X26
----	---	-----

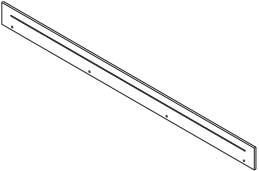
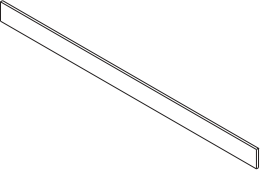
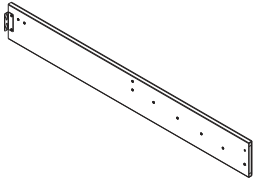
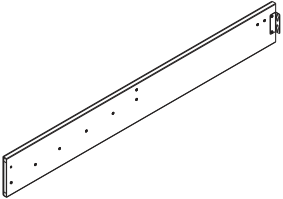

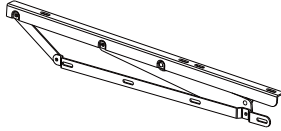
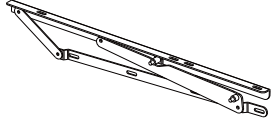
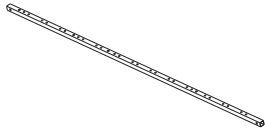
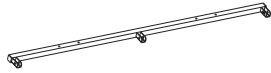

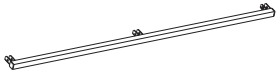

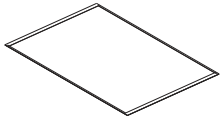
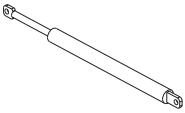
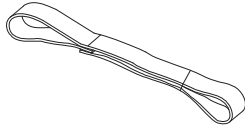



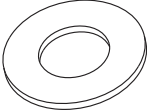

N616P425631

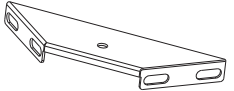
6		X1
7		X1
3L		X1
3R		X1

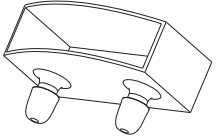
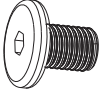
8L		X1
8R		X1
9		X3
10		X1

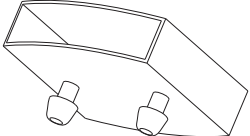
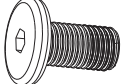
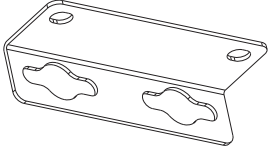
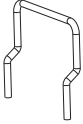
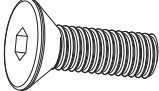
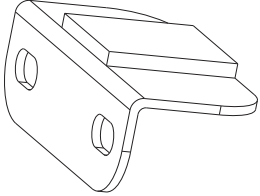
11		X1
12		X2
13		X1
14		X1
16		X2
17		X1

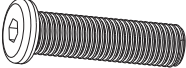
Hardware List-Hardware-Liste-Liste du matériel N616P425630

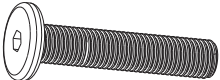
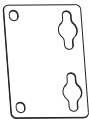
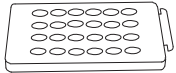
A		X1	J		X12	S		x8
B	 M4x40mm	X2	K	 M8	X16	T		x2
C	 M6 x 35mm	X2	L		X1	U		x26
D	 M8x16mm	X6	M		x10	V		x13
E	 M8x20mm	X44	N		x2	W		x2
F	 M8x18mm	X4	P		x1	X		x1
G	 M8x30mm	X12	Q		x2	Y		x1
H	 M8x40mm	X12	R		x2	Z		x1

1

A x 1



D x 6



M8 x 16mm

M x 6

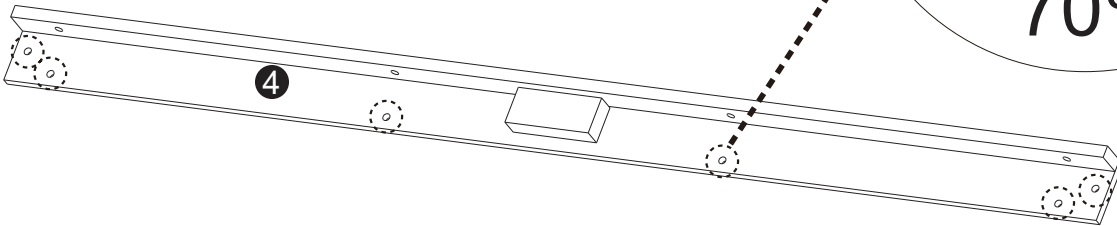
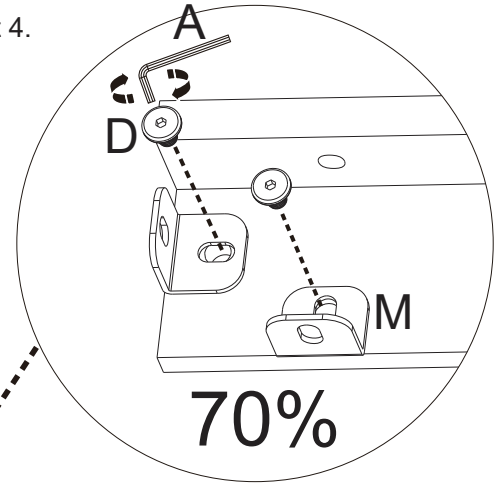

The bottom of the iron sheet needs to be flush with the edge of the part 4.
Le fond de la tôle doit être affleuré avec le bord de la partie 4.
Das blech muß mit der kante Von teil 4 ebenert werden.

**2**

A x 1



E x 4



M8 x 20mm

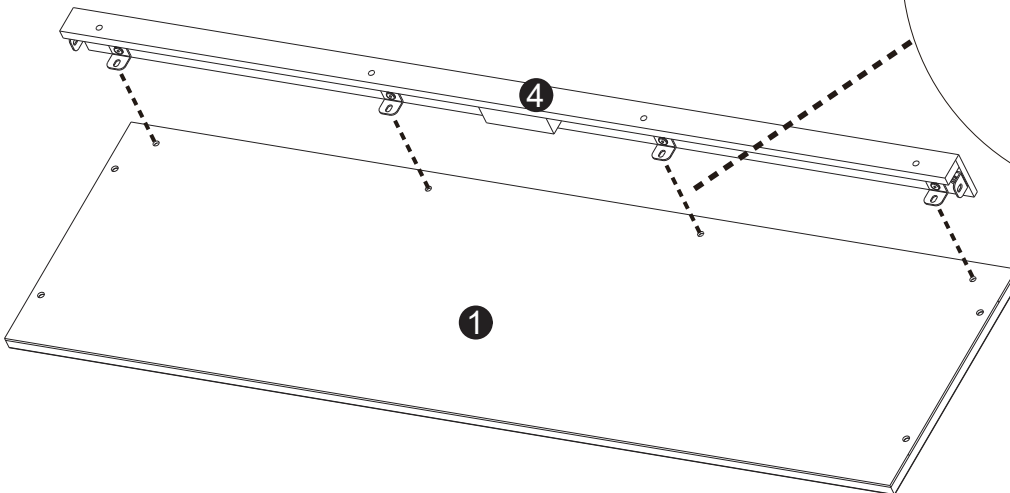
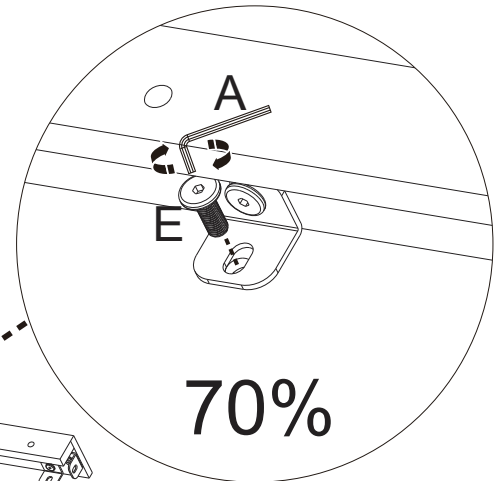

3

A x 1

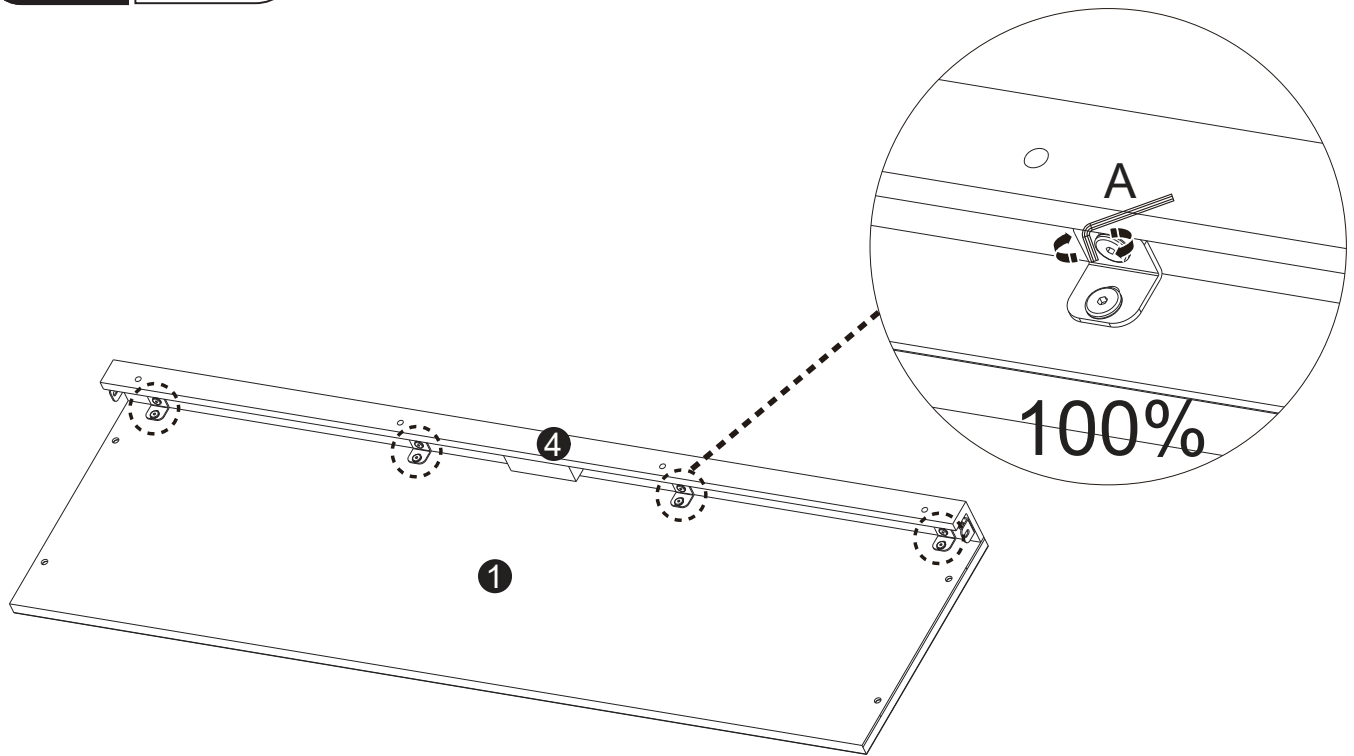

4

A x 1



G x 4



M8 x 30mm

J x 4

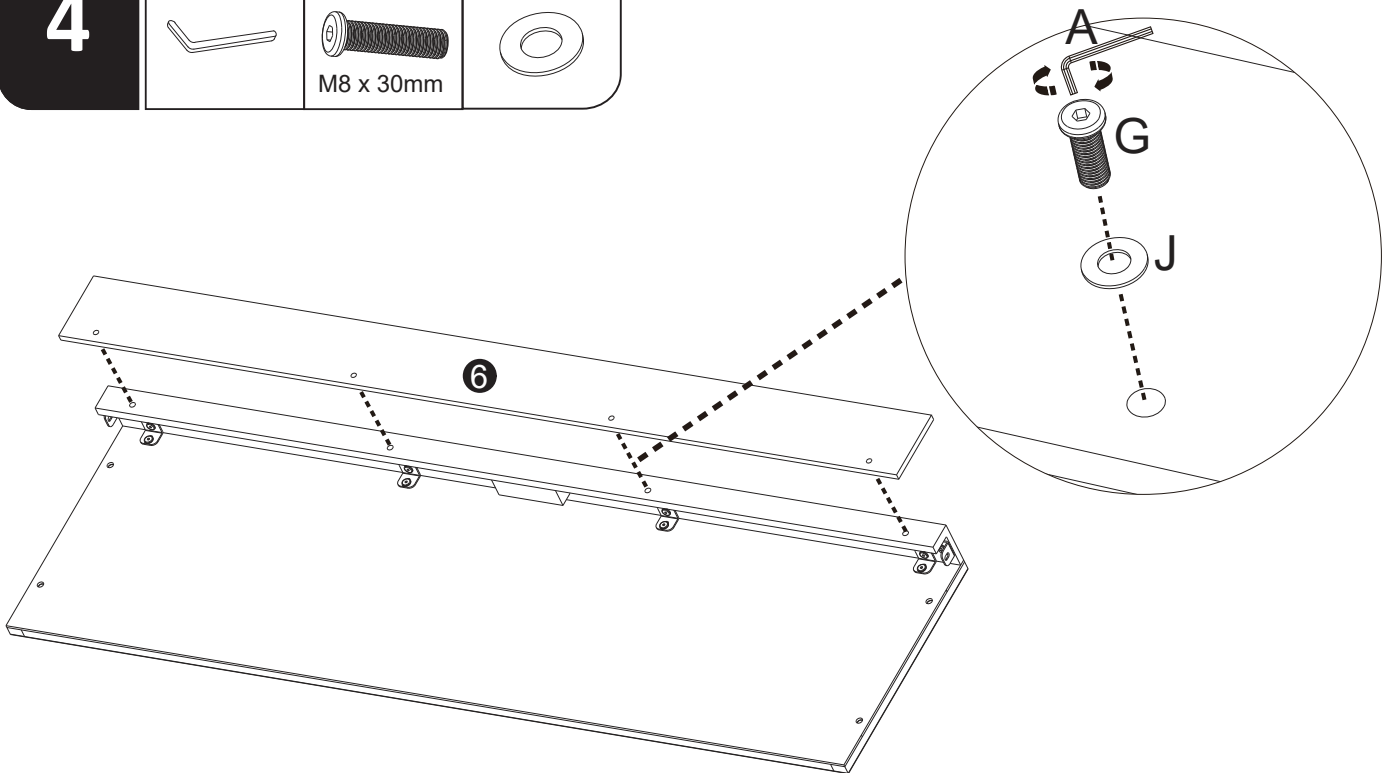

7

A x 1



E x 8



M8 x 20mm

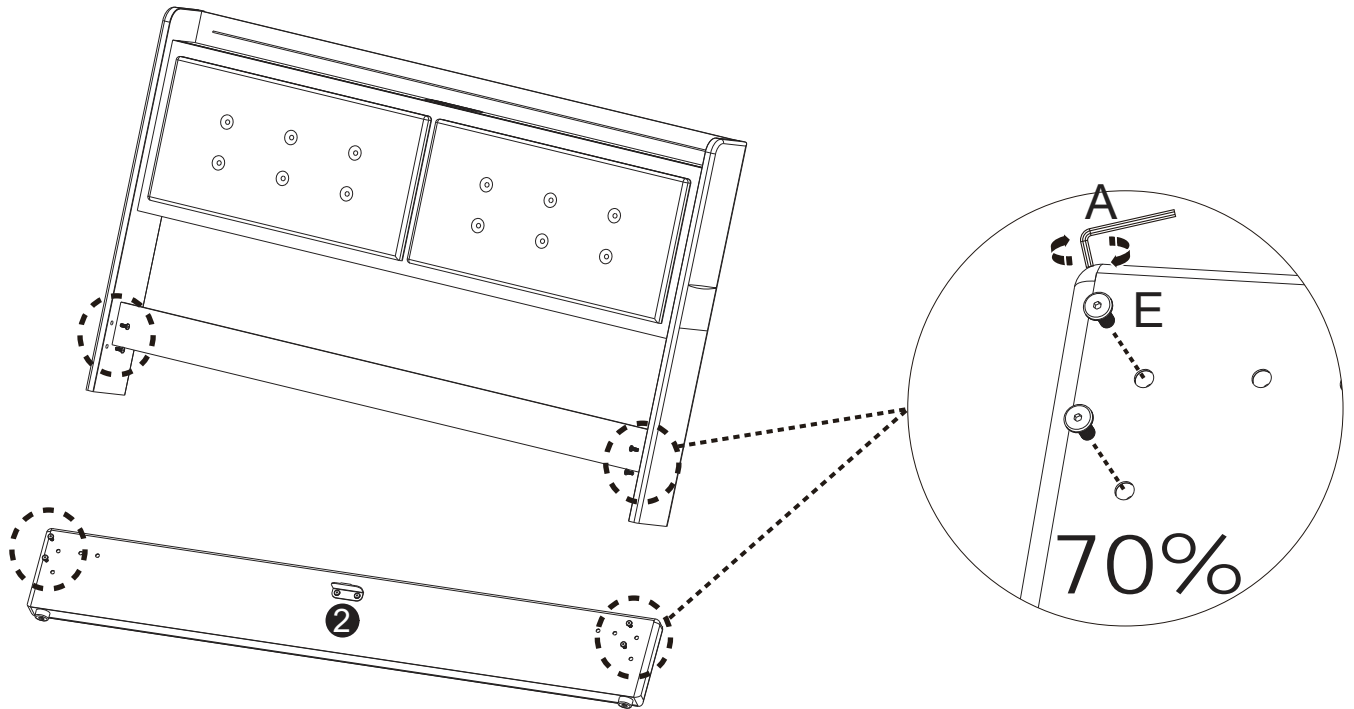

8

A x 1



E x 4



M8 x 20mm

F x 4

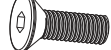

M8 x 18mm

R x 2

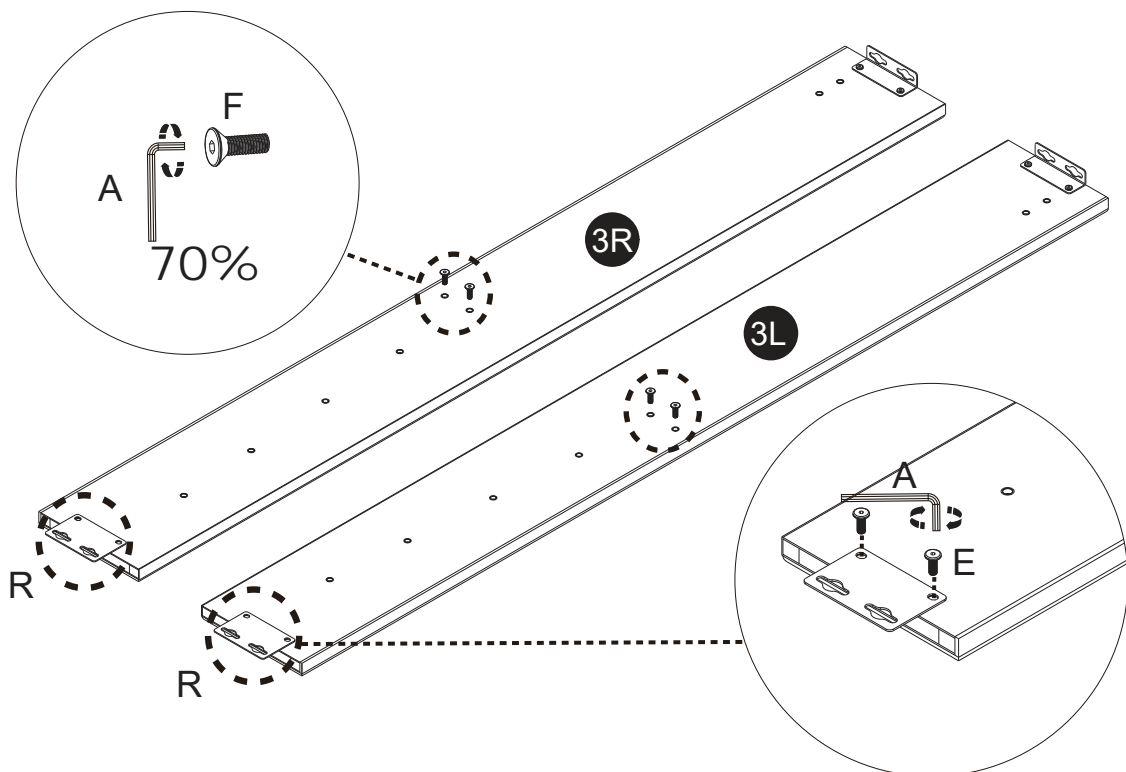

9

A x 1



G x 8



M8 x 30mm

S x 8

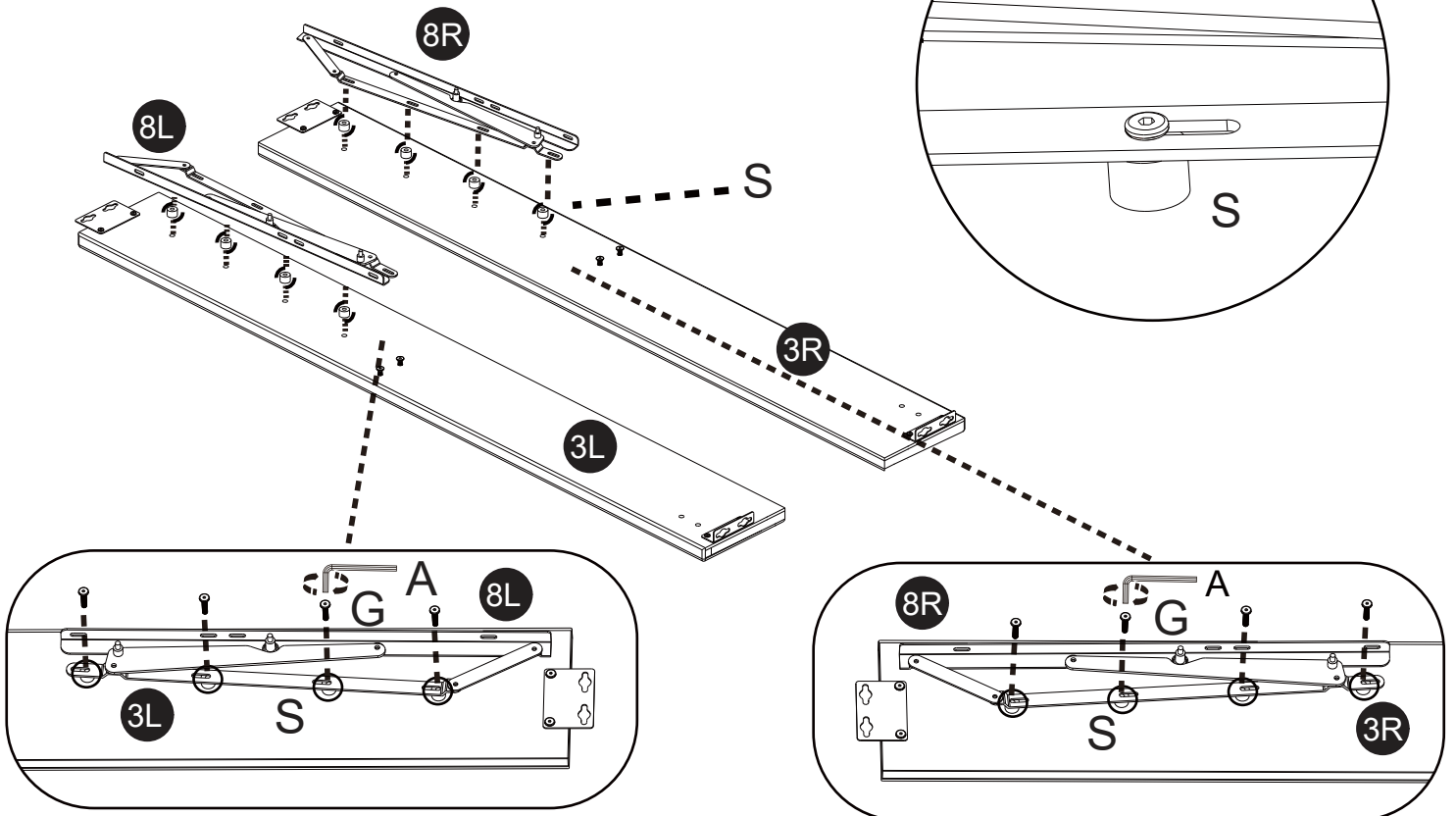

10

A x 1

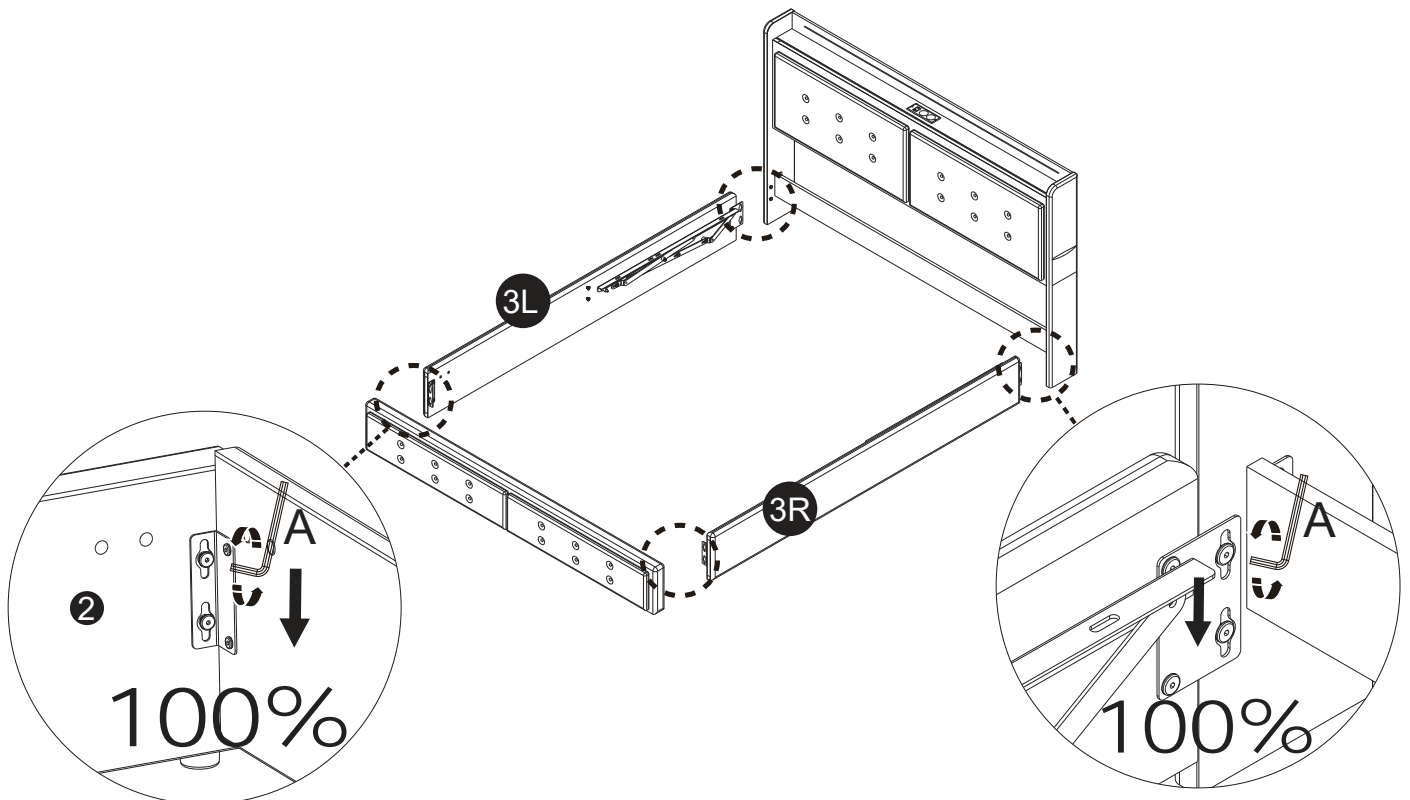

11

A x 1



E x 8



M8 x 20mm

T x 2

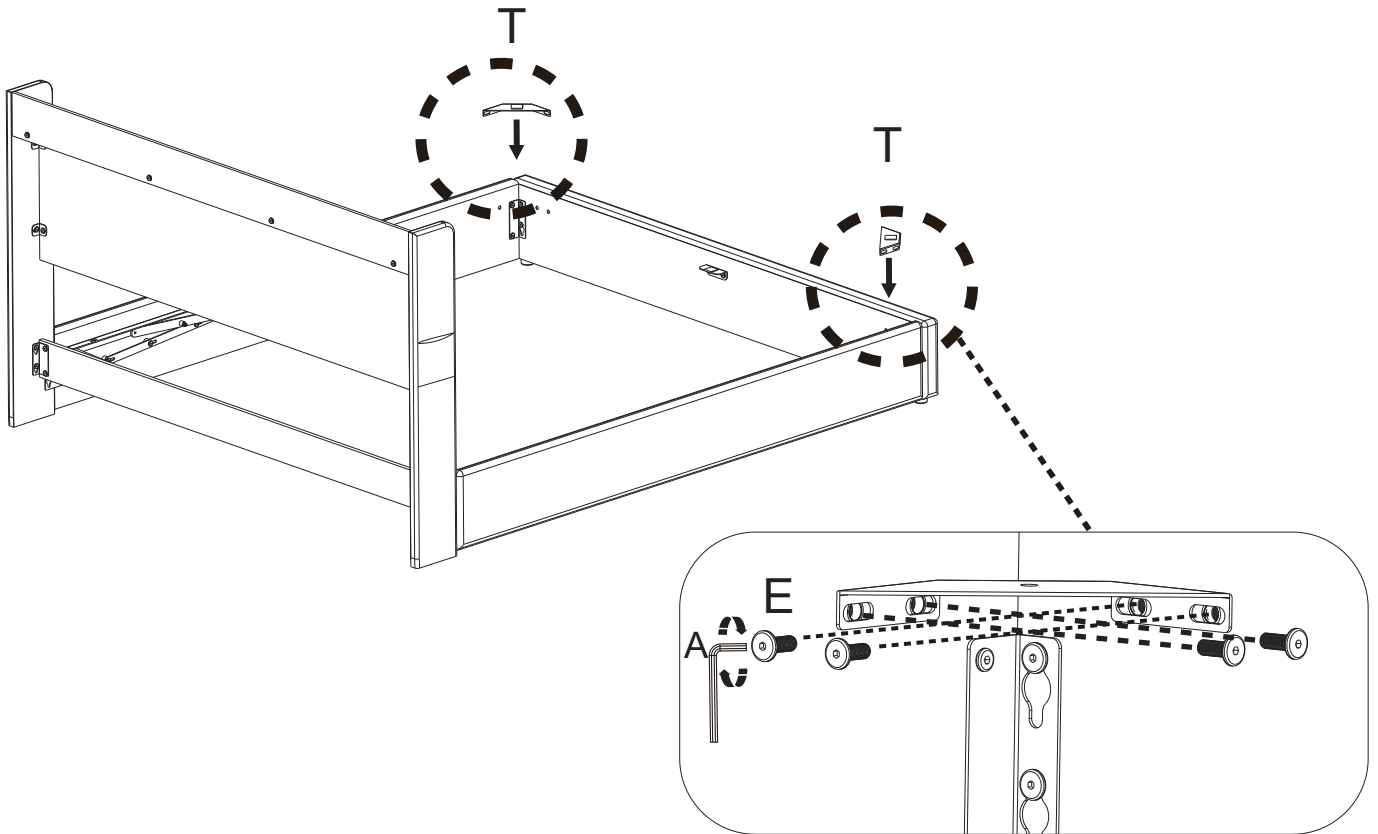
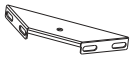

12

A x 1

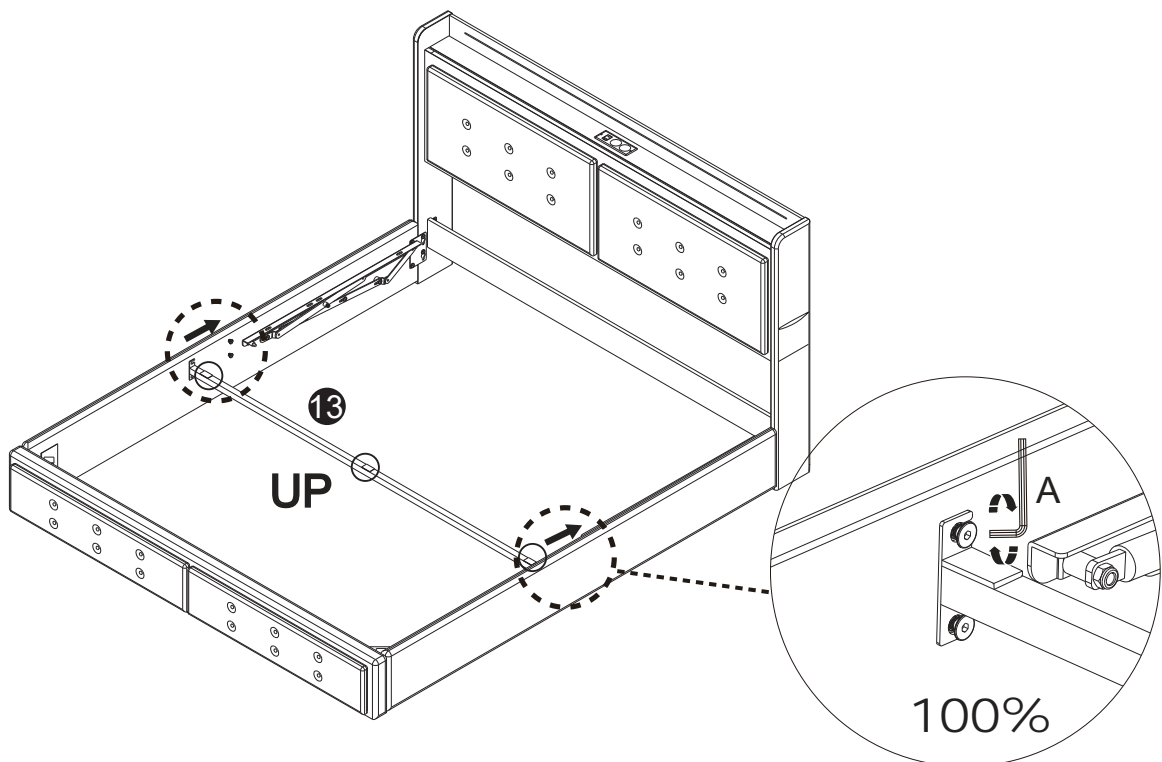

13

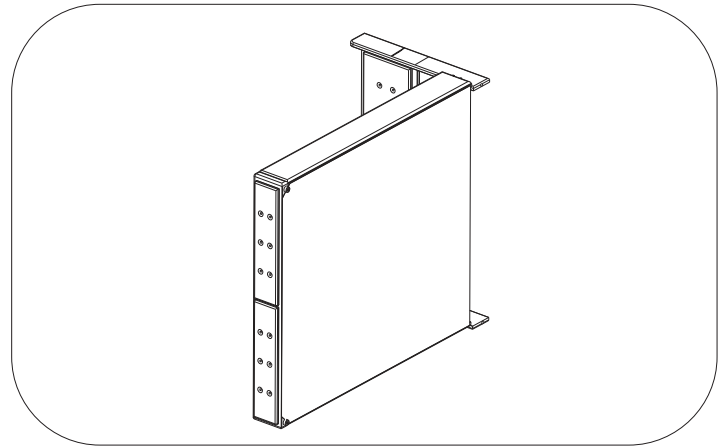
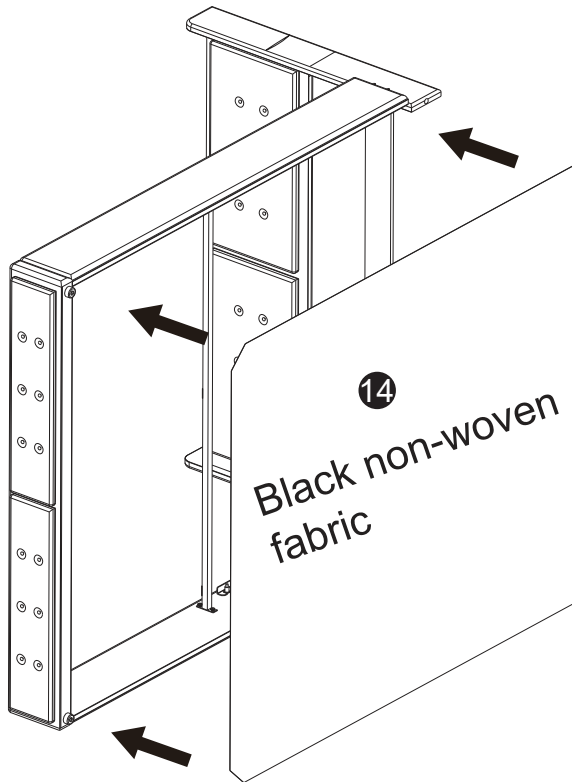

14

A x 1	H x 6 M8 x 40mm	J x 6	K x 6	L x 1

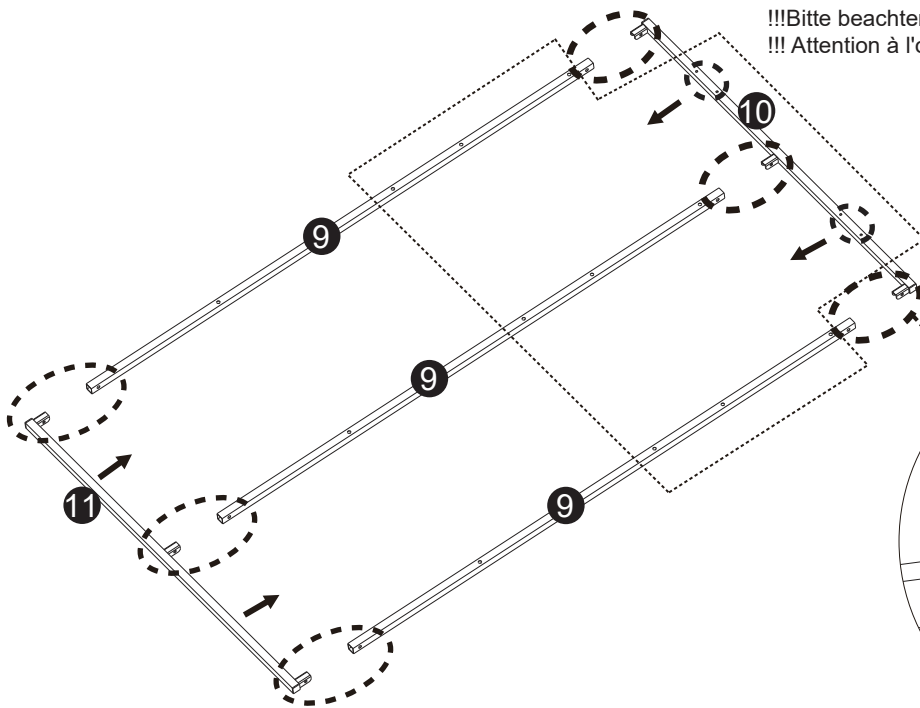

!!! Please aware the orientation of the holes on #9
!!!Bitte beachten Sie die Ausrichtung der Löcher auf #9
!!! Attention à l'orientation des trous sur le #9

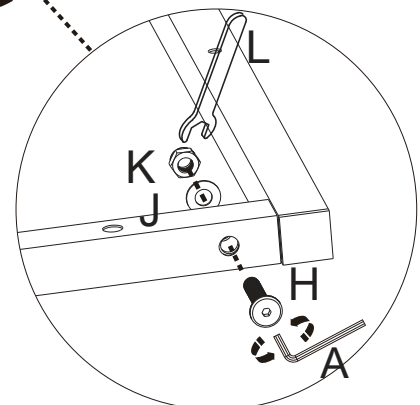

15

A x 1



C x 2



M6 x 35mm

J x 2

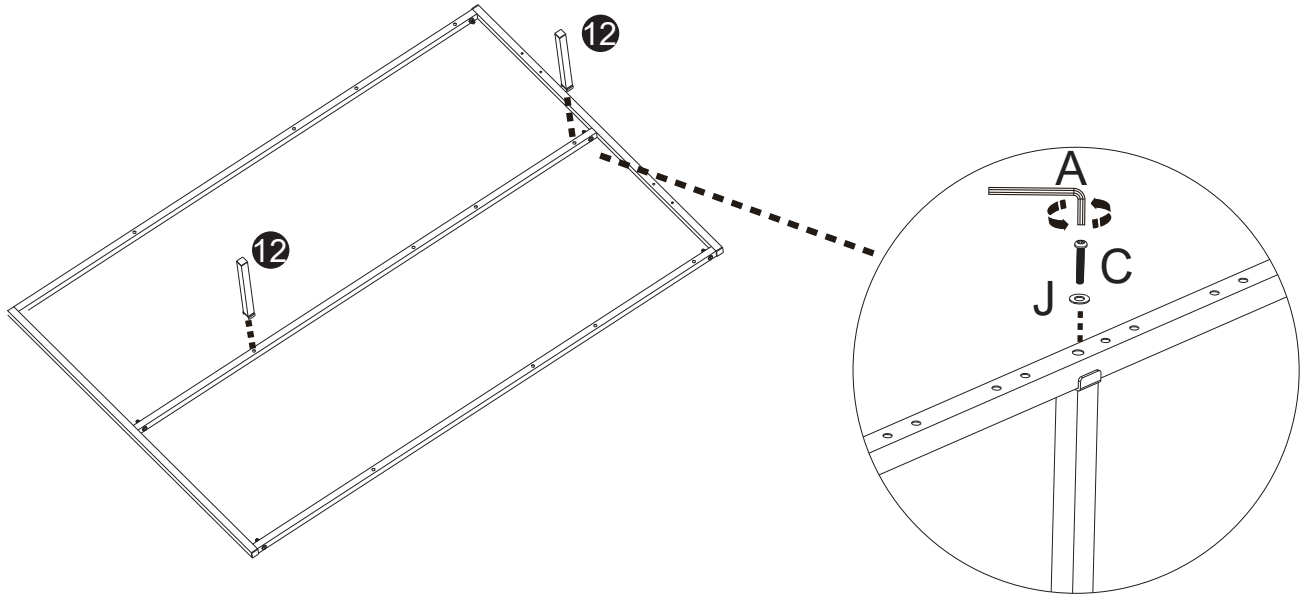

16

A x 1



H x 6



M8 x 40mm

K x 6



L x 1



W x 2

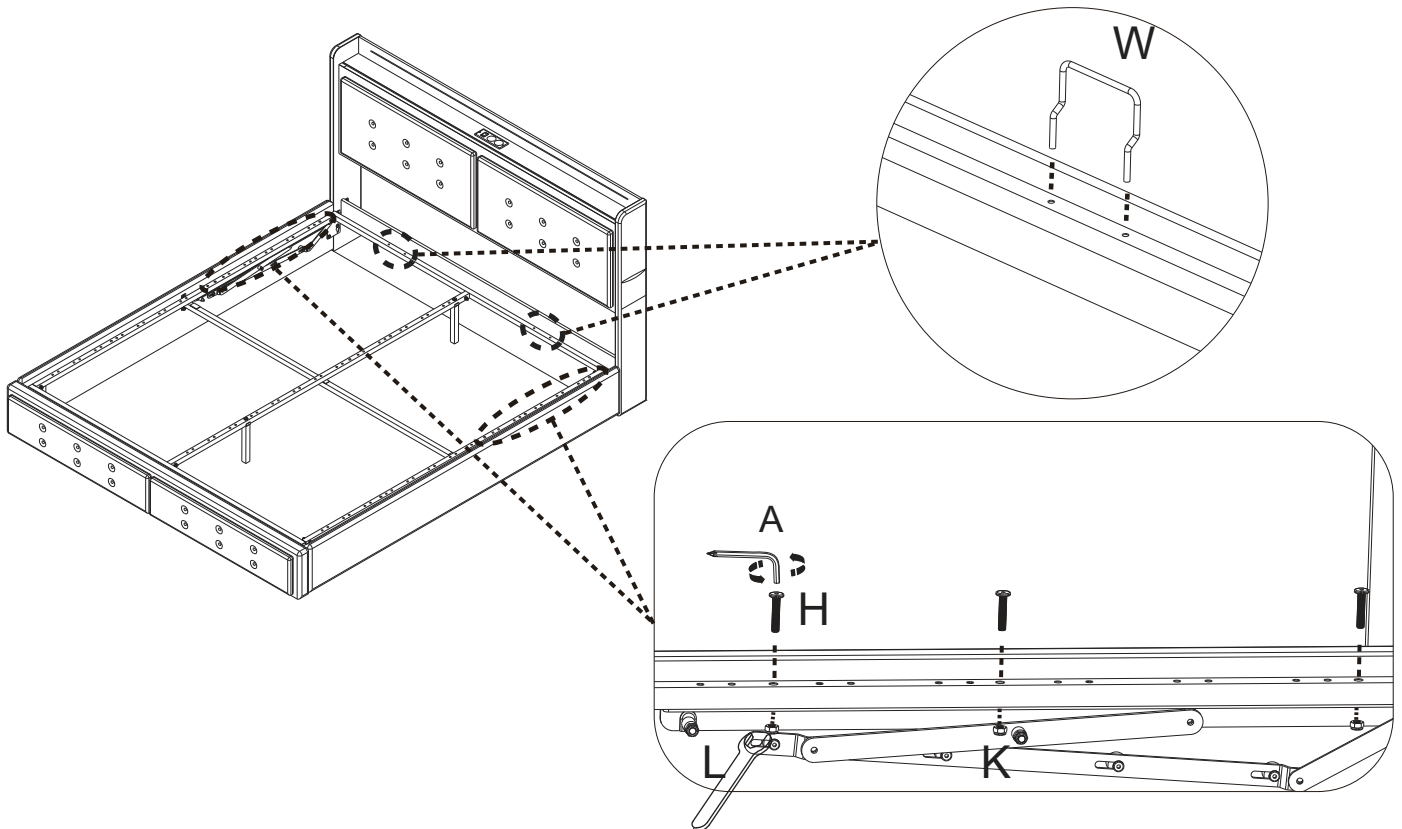

17

U x 26



V x 13



↑ UP

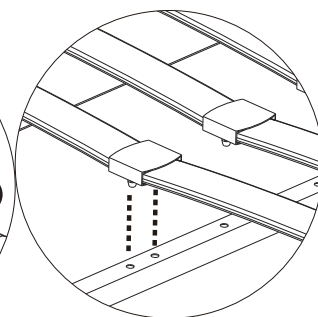
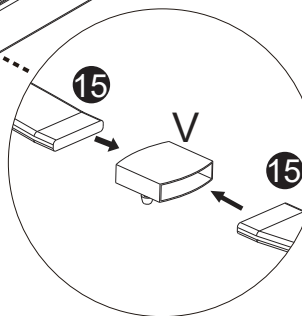
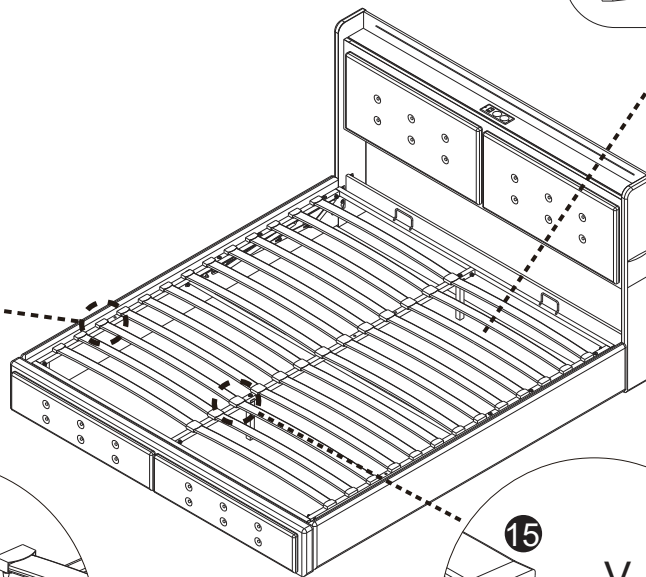
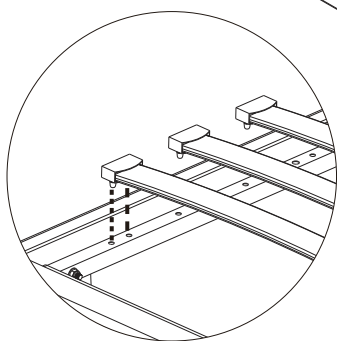
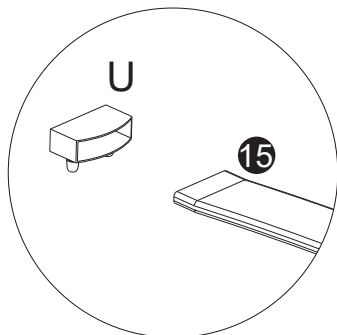

18

K x 4



L x 1



17

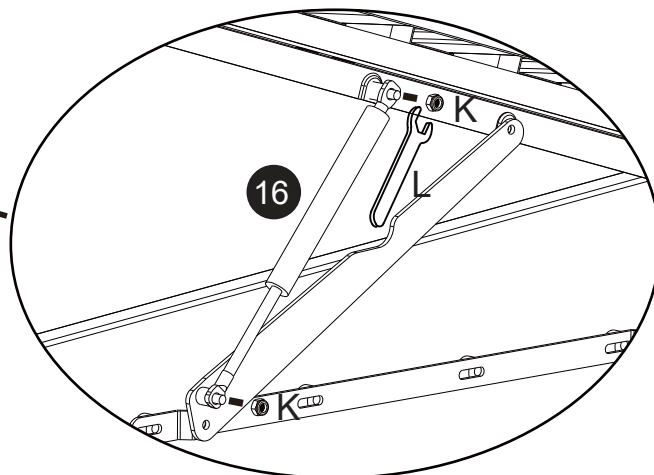
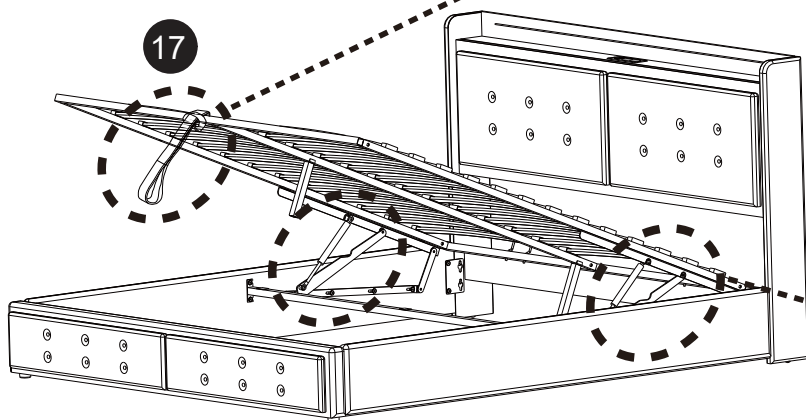
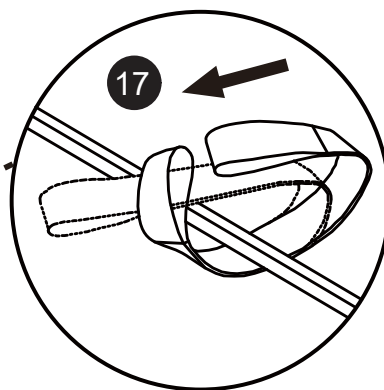

19

X x 1



Y x 1

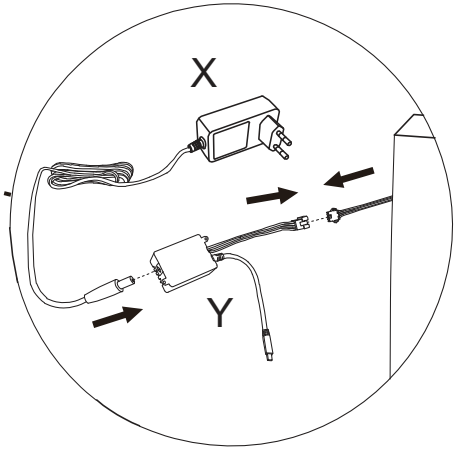
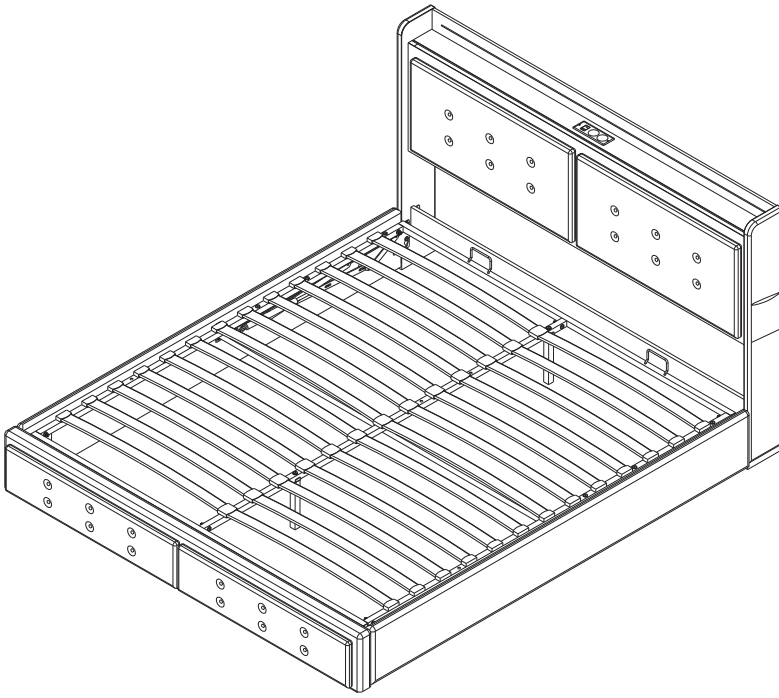
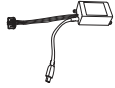

20

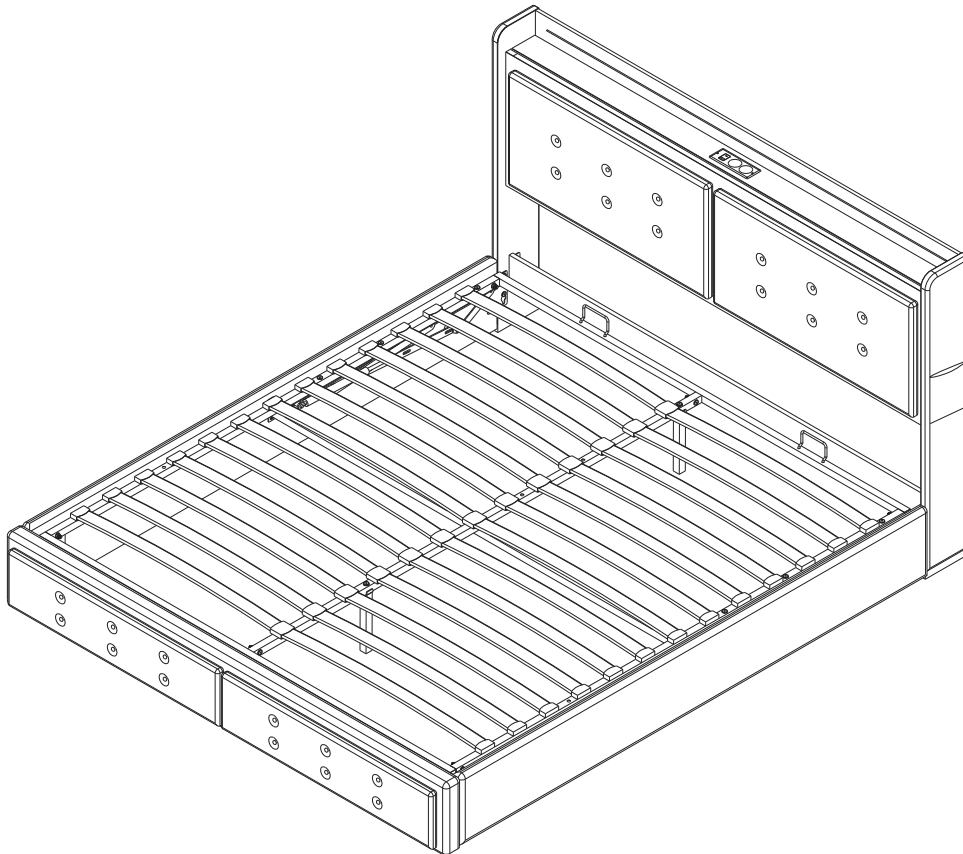

LED light

If you can't let the lights work successfully, please check the following:

1. Please check the direction of the connect, try it in the opposite direction, according to the following picture.
2. Please check the remote control, it need you to tear down the plastic septum before use it.
3. Don't let the remote control too far from the receiver, make sure there is no obstruction between them.
4. If one of the colors is not bright, please check whether the four wires in the plug are skewed, and move the main line to make the four wires flush.

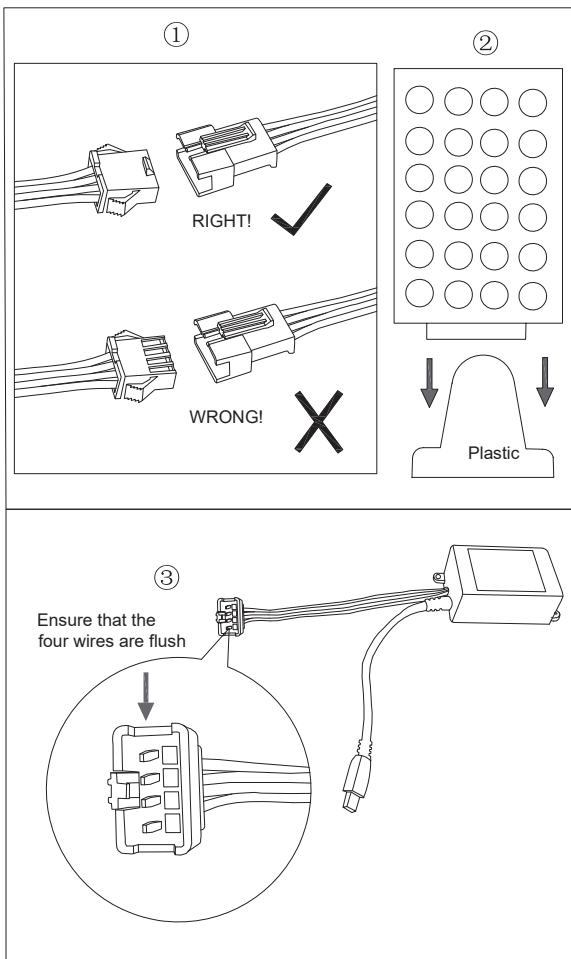

- 1 Please check the direction of the arrow
- 2 Please pull the plastic block out of the remote control
- 3 Please check whether the four wires of the plug are neat

Operation Instructions of Controller

I .Specifications:

Working temperature: -20-60 °C Supply voltage: DC12V
 Output: Three CMOS drain- open output Connecting Mode: Common anode
 Max load current: 2 A each color

II .Control Method:

Adopt IR remoter to control the led controller, which has 24 buttons, the function of each button as the table below:

Brightness +(Speed up)	Brightness - (Speed down)	Off	On
Static red	Static green	Static blue	Static white
Static orange	Static pea green	Static dark blue	7 color jumpy change
Static dark yellow	Static cyan	Static brown	All fade out&fade in
Static yellow	Static light blue	Static pink	7 color fade change
Static straw yellow	Static sky blue	Static purple	3 base color jumpy

III. Panel specification and connecting drawing as follows:

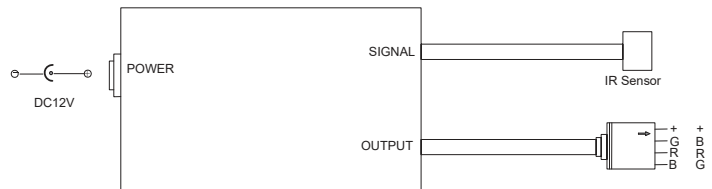

IV. Warning:

1. Supply voltage of this product is DC12V never connect to DC24V or AC220V.
2. Never connect two wires directly in case of short circuit.
3. Lead wire should be connected correctly according to colors that connecting diagram offers.
4. Warranty of this product is one year, in this period we guarantee replacement or repairing with no charge, but exclude the artificial situation of damaged or overload working.

! WARNING

THIS PRODUCT CONTAINS A BUTTON BATTERY
 If swallowed, a lithium button battery can cause severe or fatal injuries within 2 hours.
 Keep batteries out of reach of children.
 If you think batteries may have been swallowed or placed inside any part of the body, seek immediate medical attention.

CERTIFICATE OF CONFORMITY

Certificate No.: KEYS240524062001EM-02

Applicant : Foshan Wei Guang Te Lighting Technology Co.,Ltd.
Address : No.177,Bai'an South Road,Cangmen community Jun'an Town,
Shunde District,Foshan City,Guangdong Province.China
Manufacturer : Foshan Wei Guang Te Lighting Technology Co.,Ltd.
Address : No.177,Bai'an South Road,Cangmen community Jun'an Town,
Shunde District,Foshan City,Guangdong Province.China
Trade mark : Wei Guang Te
Product : LED Light Bar
Model No. : WGT-A221116-12W,WGT-M2706-12W,WGT-M1808-12W,
WGT-A250618-12W,WGT-A151010-12W,WGT-A221116-3W,
WGT-A221116-5W,WGT-A221116-7W,WGT-A221116-9W,
WGT-A221116-10W,WGT-M2706-3W,WGT-M2706-5W,
WGT-M2706-7W,WGT-M2706-9W,WGT-M2706-10W,WGT-M1808-3W,
WGT-M1808-5W,WGT-M1808-7W,WGT-M1808-9W,WGT-M1808-10W,
WGT-A250618-3W,WGT-A250618-5W,WGT-A250618-7W,
WGT-A250618-9W,WGT-A250618-10W,WGT-A250618-3W,
WGT-A250618-5W,WGT-A250618-7W,WGT-A250618-9W,
WGT-A250618-10W,WGT-A151010-3W,WGT-A151010-5W,
WGT-A151010-7W,WGT-A151010-9W,WGT-A151010-10W

The submitted sample of the above equipment has been tested and found to comply with the following European Directive:

EMC Directive - 2014/30/EU

The standard(s) used for showing compliance with the essential requirements:

Applicable Standard(s) EN IEC 55015:2019+A11:2020
EN IEC 61547:2023
EN IEC 61000-3-2:2019+A1:2021
EN 61000-3-3:2013+A1:2019+A2:2021

This certificate is part of the full test report(s) and should be read in conjunction with the test report: KEYS240524062001EM-02.

This certificate is based on an evaluation of one sample of above mentioned product. It does not imply assessment of the production of the product. Without the written approval of Guangdong KEYS Testing Technology Co., Ltd., this certificate is not permitted to be reproduced, except in full. It is not permitted to use the test lab's logo. The CE marking may only be used if all the relevant and effective European Directives are applicable.



Date: May 31, 2024

Guangdong KEYS Testing Technology Co., Ltd.

Address: Building 1, No.18, Shihuan Road, Dongcheng Subdistrict, Dongguan, Guangdong, China

104, No.4, Fumin Street, Shilong, Dongguan, Guangdong, China

Tel:+ 86-0769-89798319 <http://www.keys-lab.com> E-mail: info@keys-lab.com

Certificate

Certificate Number: UNIA22051009EC-11



Product: Power Adapter

Applicant: Zhongshan Yabo Electronic Technology Co., Ltd.
4/f, 23 Kwong Lok Centre road, Lianfeng, Xiaolan, Zhongshan

Manufacturer: Zhongshan Yabo Electronic Technology Co., Ltd.
4/f, 23 Kwong Lok Centre road, Lianfeng, Xiaolan, Zhongshan

Model No.: YB-1236, YB-1224, YB-1212

Trade Name: 雅之博

Test Methods: EN IEC 55015:2019/A11:2020
EN IEC 61000-3-2:2019/A1:2021
EN 61000-3-3:2013/A2:2021/AC:2022-01
EN 61547:2009

The laboratory tested the product provided by the applicant according to the above test methods. According to the test results, the product conforms to EMC Directive (2014/30/EU) issued by the European Commission. It is possible to use CE marking to demonstrate the compliance with EMC Directive.

The certificate applies to the tested sample above mentioned only and shall not imply an assessment of the whole production. It is only valid in connection with the test report number: UNIA22051009ER-11.

May 25, 2022
Issue Date

A handwritten signature in black ink, appearing to read "Hoffer Lau".



Shenzhen United Testing Technology Co., Ltd.

Shenzhen: 2/F., Annex Building, Jiahuangyuan Tech Park, No.305, Baojian 1st Road, Tiegang, Xixiang Street, Bao'an District, Shenzhen, Guangdong, China/518050

Guangzhou: No.47-3, Industrial Road, Zhushan, Dalong Street, Panyu District, Guangzhou, Guangdong, China/511450

Tel: +86-755-86180996 / +86-020-39277769 Fax: +86-0755-86180156

Web Site: www.uni-lab.hk/ E-mail: hofferlau@uni-lab.hk



Certificate of Compliance



CERTIFICATE OF CONFORMITY

Electromagnetic Compatibility (EMC) Directive 2014/30/EU

This Certificate of Conformity is hereby issued to the product designated below:

Certificate No. : 23EP08001E01
Report No. : EP2308001E01
Date Issue. : 2023-08-23
Applicant's name : Shenzhen MingFuXin Furniture Electrical Appliances Co., Ltd.
Address : 4 F, building a, No. 8, Chenwu Road, Dakang community, Yuanshan street, Longgang District, Shenzhen
Manufacturer's name : Shenzhen MingFuXin Furniture Electrical Appliances Co., Ltd.
Address : 4 F, building a, No. 8, Chenwu Road, Dakang community, Yuanshan street, Longgang District, Shenzhen
Product Description : Socket
Model(s)/Type References : OAZ-XXXX(The 1st "X" represents the switch, 0-1, the 2nd "X" represents the number of sockets 1-4, the 3th "X" represents the number of USB 1-3 (1 is double A, 2 is A+C,3 is double C), and the 4th "X" represents the wireless charge 0-1)
Parameters : See attachment for details
Standard(s) : EN 55032:2015+A11:2020+A1:2020
EN 55035:2017+A11:2020
EN IEC 61000-3-2:2019+A1:2021
EN 61000-3-3:2013+A1:2019+A2:2021

On the basis of the referenced test report(s), sample(s) tested of the above product have been found to comply with the standards harmonized with the directives listed on this verification at the time the tests were carried out. Other standards and Directives may be relevant to the product. This verification is part of the full test report(s) and should be read in conjunction with it(them).

Once compliance with all product relevant CE mark directives are verified, including any relevant e.g. risk assessment and production control, the manufacturer may indicate compliance by signing a Declaration of Conformity themselves and applying the mark to products identical to the tested sample(s).

Approved By

Eric Liu
Director of engineering department

Dongguan Pubiao Testing Technology Co., Ltd

No. 3, 1/F., Building A, No.30, Minghua Road, Juzhou, Shijie, Dongguan, Guangdong, China

Tel: +86 769 81813516 E-mail: service@pubiaotest.com Web: www.pubiaotest.com



CERTIFICATE OF CONFORMITY

Electromagnetic Compatibility (EMC) Directive 2014/30/EU

Appendix of Certificate No.: 23EP08001E01

Parameters:

Input: 220-250Vac, 50Hz, 10A

Output: AC socket: 2500W max

1)For USBA+Type-C output:

Type-C: 5VDC3A/9VDC2.22A/12VDC1.67A

USBA:5VDC3A/9VDC2A/12VDC1.5A

Type-C&USB: 5VDC/3A

Wireless:15W max

2)For double C output:

Type-C1: 5VDC3A/9VDC2.22A/12VDC1.67A

Type-C2:5VDC3A/9VDC2A/12VDC1.5A

Type-C1&Type-C2: 5VDC/3A

Wireless:15W max

3)For double A output:

USBA1:5VDC 2.1A

USBA2:5VDC 2.1A

USBA1&USBA2:5VDC/2.1A

Wireless:15W max



Dongguan Pubiao Testing Technology Co., Ltd

No. 3, 1/F., Building A, No.30, Minghua Road, Juzhou, Shijie, Dongguan, Guangdong, China

Tel: +86 769 81813516 E-mail: service@pubiaotest.com Web: www.pubiaotest.com

EN:Battery Safety Instructions

1. Do not dispose of used button batteries or remote controls in household trash. To protect the environment and prevent hazardous leakage, please follow these guidelines:
2. Remove button batteries after use and take them to a local battery recycling point or hazardous waste collection site.
3. Do not burn or dismantle the batteries to avoid explosion or toxic release.
4. If the remote control is no longer in use, please deliver it to a certified electronics recycling facility to promote resource reuse.
5. Keep out of reach of children to prevent accidental ingestion or injury.
6. This product does not include batteries; please purchase them separately. The compatible button cell model for the remote control is CR2025 3V
7. If the light strip is not working, please try replacing the battery first. If the issue persists, contact the seller for assistance.

Keep the remote control away from children — keep it away from children! If the battery is accidentally swallowed, seek medical attention immediately.

DE: Batteriesicherheitshinweise

1. Entsorgen Sie gebrauchte Knopfzellen oder Fernbedienungen nicht im Hausmüll. Um die Umwelt zu schützen und gefährliche Leckagen zu vermeiden, beachten Sie bitte die folgenden
2. Entfernen Sie die Knopfzelle nach dem Gebrauch und bringen Sie sie zu einer örtlichen Batteriesammelstelle oder einem Sondermüllentsorgungszentrum.
3. Batterien nicht verbrennen oder zerlegen, um Explosionen oder die Freisetzung giftiger Stoffe zu vermeiden.
4. Wenn die Fernbedienung nicht mehr verwendet wird, bringen Sie sie zu einer zertifizierten Elektronik-Recyclingstelle, um eine Wiederverwertung zu ermöglichen.
5. Außerhalb der Reichweite von Kindern aufbewahren, um versehentliches Verschlucken oder Verletzungen zu verhindern.
6. Dieses Produkt enthält keine Batterien. Bitte kaufen Sie diese separat. Das kompatible Knopfzellenmodell für die Fernbedienung ist CR2025 3V
7. Wenn der Lichtstreifen nicht funktioniert, versuchen Sie zunächst, die Batterie zu wechseln. Besteht das Problem weiterhin, kontaktieren Sie bitte den Verkäufer.

Halten Sie die Fernbedienung unbedingt von Kindern fern — unbedingt fernhalten! Wird die Batterie versehentlich verschluckt, suchen Sie sofort medizinische Hilfe auf.

FR:Instructions de sécurité pour les piles

1. Ne jetez pas les piles bouton usagées ou les télécommandes à la poubelle ménagère. Pour protéger l' environnement et éviter tout risque de fuite dangereuse, veuillez suivre les consignes suivantes :

2. Retirez les piles bouton après usage et déposez-les dans un point de collecte local ou un centre de déchets dangereux.

3. Ne brûlez pas et ne démontez pas les piles, cela pourrait entraîner une explosion ou libérer des substances toxiques.

4. Si la télécommande n'est plus utilisée, déposez-la dans un centre de recyclage agréé pour appareils électroniques, afin de favoriser la réutilisation des ressources.

5. Gardez hors de portée des enfants pour éviter tout risque d'ingestion accidentelle ou de blessure.

6.Ce produit ne contient pas de pile. Veuillez l'acheter séparément. Le modèle de pile bouton compatible pour la télécommande est CR2025 3V

7.Si le ruban LED ne fonctionne pas, essayez d'abord de remplacer la pile. Si le problème persiste, contactez le vendeur.

8.Tenez la télécommande éloignée des enfants — éloignez-la vraiment ! En cas d'ingestion accidentelle de la pile, consultez immédiatement un médecin.



1



2



3



4



5



6



7



Modell : CR2025 3.V

8



9



10

